

[54] SECURITY SYSTEM AND LOCK THEREFOR 3,587,081 6/1971 Hawkins et al. .... 340/274  
 3,714,643 1/1973 Sosin et al. .... 340/274

[75] Inventor: Francis C. Peterson, St. Louis County, Mo.

Primary Examiner—Glen R. Swann, III  
 Attorney, Agent, or Firm—Gravely, Lieder & Woodruff

[73] Assignee: Hinge Manufacturing Company, St. Louis, Mo.

[22] Filed: May 22, 1973

[57] ABSTRACT

[21] Appl. No.: 362,662

A security system includes a lock for securing a door and an alarm to signal when the door is ajar. The lock has a latch bolt which projects into a keeper in the door frame and an operating mechanism for retracting the latch bolt. A key operated locking device when locked prevents the operating mechanism from retracting the latch bolt. When the key operated locking device is unlocked with the proper key to enable the latch bolt to be retracted, a switch closes to deactivate the alarm long enough to enable one to open the door, pass through the door opening, and then close the door.

[52] U.S. Cl. .... 340/274, 200/61.64

[51] Int. Cl. .... G08b 13/08

[58] Field of Search ..... 340/274; 200/61.67, 61.64, 200/61.93

[56] References Cited

UNITED STATES PATENTS

1,674,570	6/1928	Re.....	340/274
2,437,777	3/1948	Zajk.....	340/274
2,617,868	11/1952	Menkin.....	340/274
3,353,383	11/1967	Fish.....	340/274

16 Claims, 6 Drawing Figures

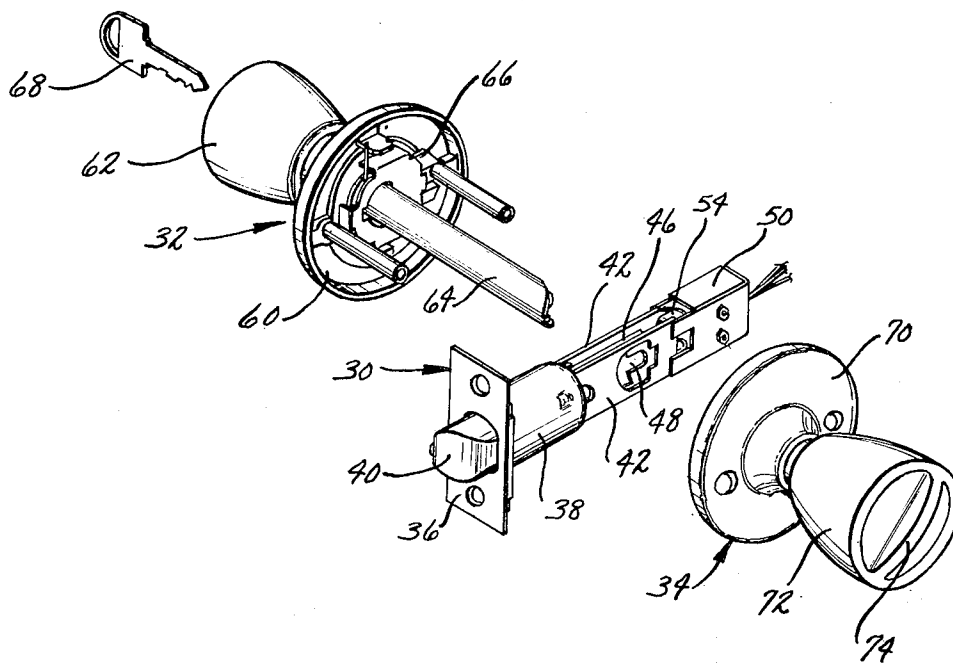

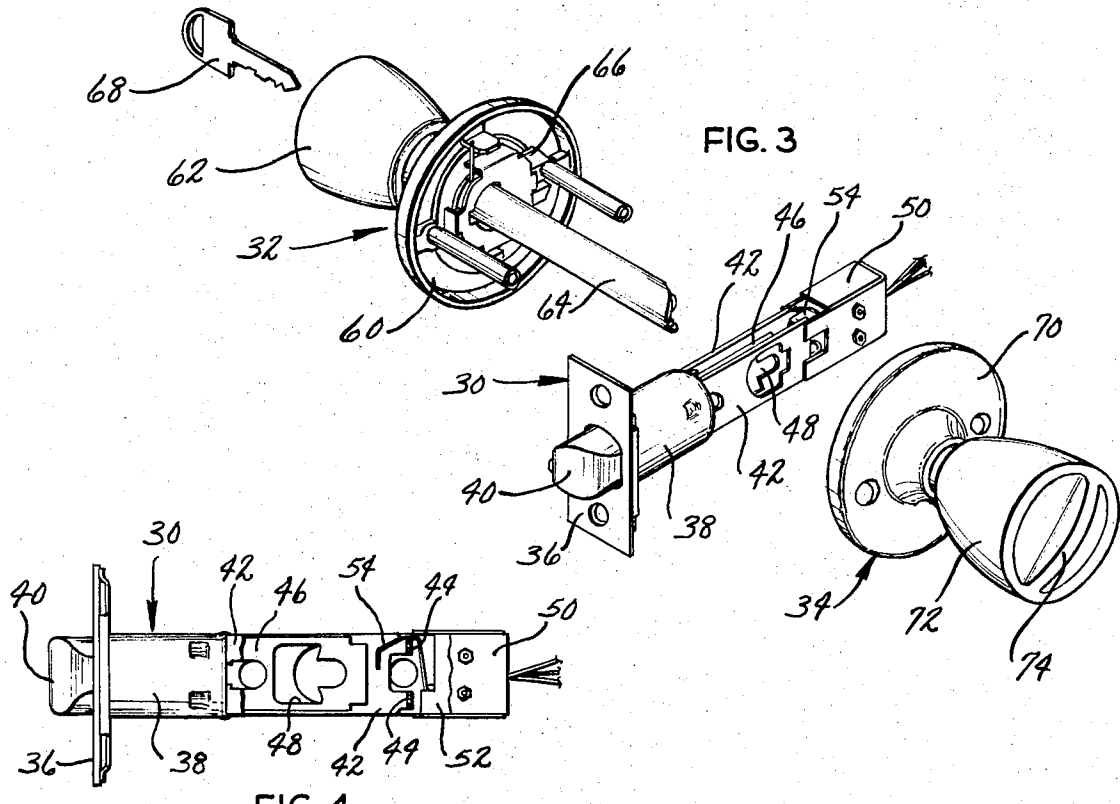
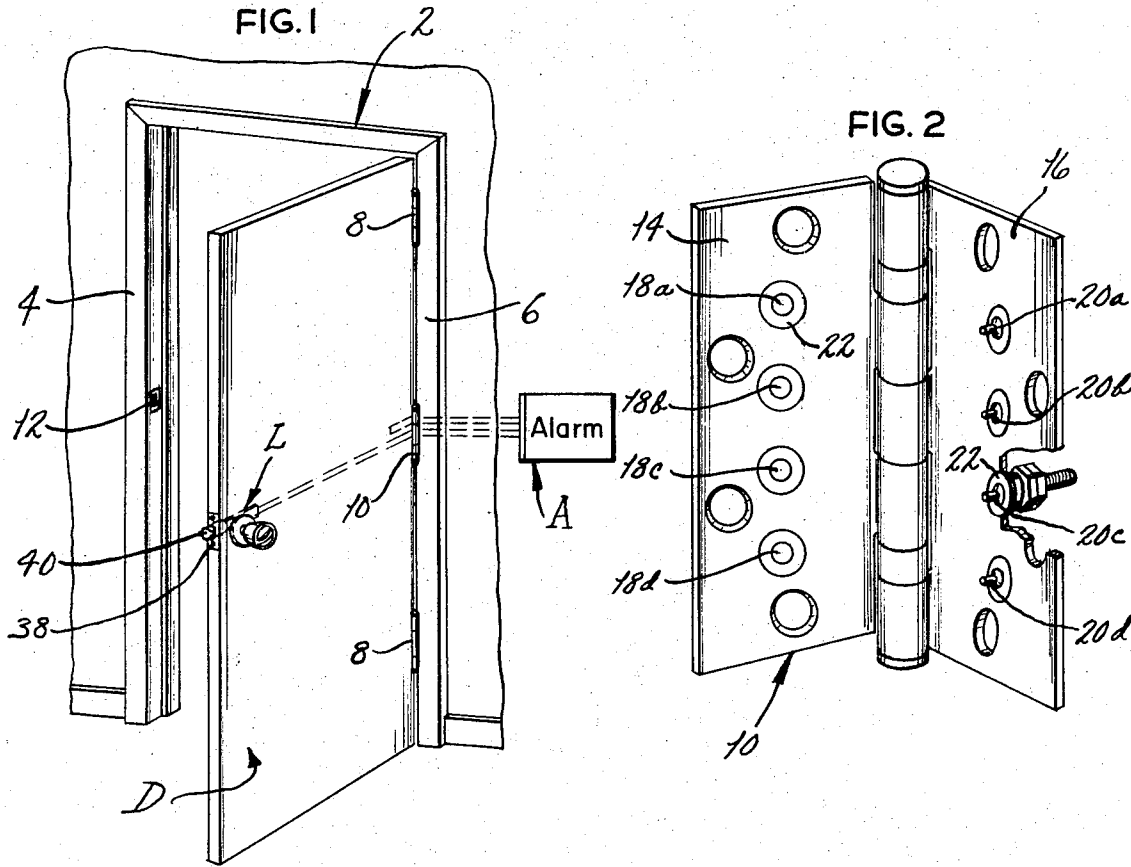

FIG. 3

FIG. 5

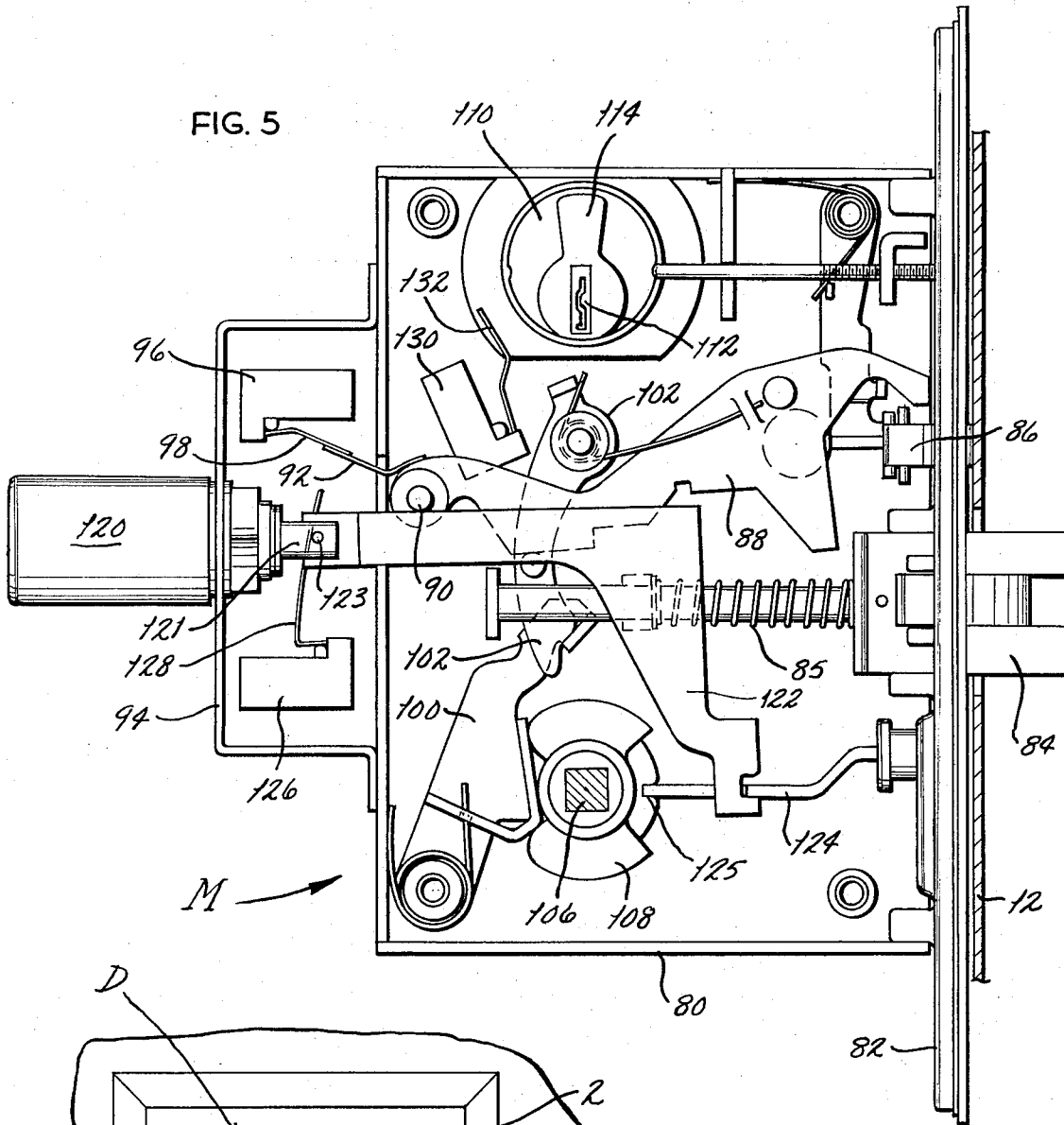
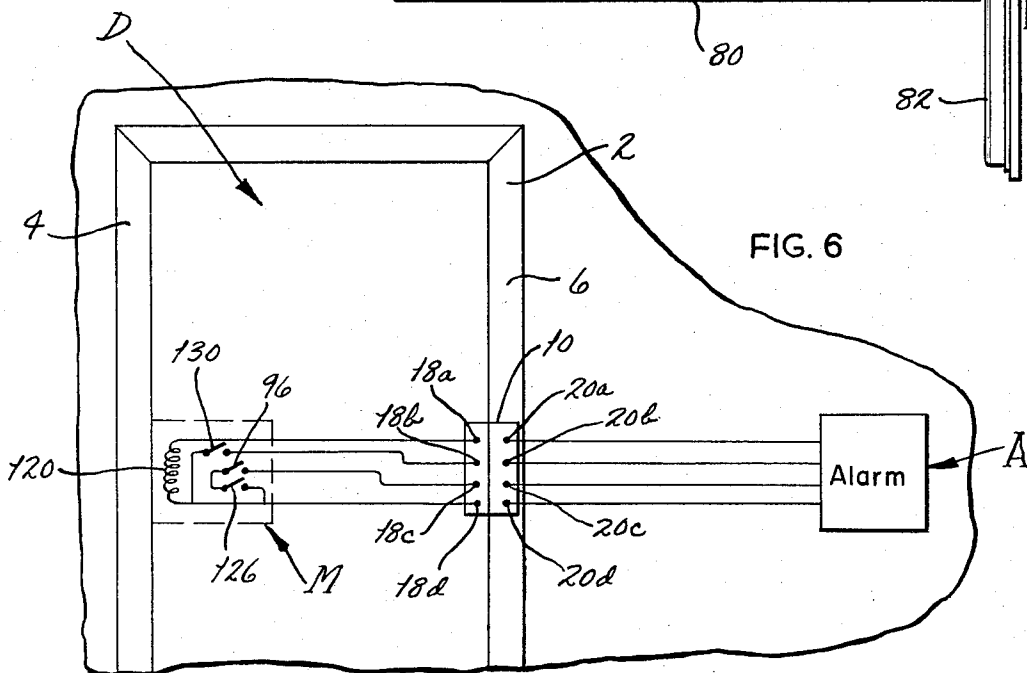

FIG. 6



## SECURITY SYSTEM AND LOCK THEREFOR

## BACKGROUND OF THE INVENTION

This invention relates in general to security systems and more particularly to a security system having an alarm to signal security breaks at a locked door and means for deactivating the alarm when authorized personnel unlock the door.

The operators of many large office buildings, warehouses, and the like employ security personnel to patrol the buildings and prevent unauthorized entry. This is quite expensive, and by reason of this fact, many buildings of recent construction have electrical security systems for maintaining surveillance over doors at critical locations therein and for controlling the locks which secure those doors. These systems are usually provided with key operated switches in the door jambs to deactivate the alarm system for a short interval of time so that authorized personnel can pass through the doors without triggering the alarm. Usually the switches activate a time delay which deactivates the alarm for about 20 seconds—time enough for the individual to unlock the door, pass through the door opening, and then close the door again. These systems are quite bothersome to those who use them, since two key locks must be operated to pass through each door.

## SUMMARY OF THE INVENTION

One of the principal objects of the present invention is to provide a security system which enables authorized personnel to pass through doors without setting off an alarm and with minimum inconvenience. A further object is to provide a security system of the type stated which utilizes locks of current construction having easily performed modifications. An additional object is to provide a lock suitable for use in a security system of the type stated. These and other objects and advantages will become apparent hereinafter.

The present invention is embodied in a security system having an alarm and a lock for securing a door. The lock may be released by release means which further operates means for deactivating the alarm so that authorized personnel can pass through the door without triggering the alarm. The invention also resides in the lock itself. The invention also consists in the parts and in the arrangements and combinations of parts hereinafter described and claimed.

## DESCRIPTION OF THE DRAWINGS

In the accompanying drawings which form part of the specification and wherein like numerals and letters refer to like parts wherever they occur.

FIG. 1 is a perspective view of a door connected with an alarm and having a lock constructed in accordance with and embodying the present invention;

FIG. 2 is a perspective view of a hinge used on the door illustrated in FIG. 1;

FIG. 3 is an exploded perspective view of one of the locks forming part of the present invention;

FIG. 4 is an elevational view, partially broken away, of the latch assembly for the lock illustrated in FIG. 3;

FIG. 5 is a sectional view in elevation showing another lock forming part of the present invention; and

## DETAILED DESCRIPTION

Referring now to the drawings (FIG. 1), a security system has a door D which is hung on and swings away from a door frame 2 having a strike jamb 4 and a hinge jamb 6. The door D is actually hung on hinges 8 and 10 which are attached to the hinge jamb 6. The hinges 8 are conventional full mortise hinges, while the hinge 10, besides being a full mortise hinge, is also so-called contact hinge which completes several electrical circuits when closed. The door D is provided with a lock L, while the strike jamb 4 is fitted with an apertured strike or keeper 12 which the lock L engages and thereby prevents opening of the door D.

The contact hinge 10 (FIG. 2) is disclosed in U.S. Pat. No. 3,659,063, and for purposes of this discussion it is sufficient to note that the hinge 10, like the conventional hinges 8, has leaves 14 and 16, but that the leaf 14 has four contacts 18a, 18b, 18c, and 18d, while the other leaf 16 has four spring loaded contactors 20a, 20b, 20c and 20d which align with and engage the contacts 18a, 18b, 18c and 18d, respectively, when the hinge 10 is closed. However, when the hinge 10 opens, the contacts 18 separate from their respective contactors 20. The contacts 18 and contactors 20 are set in dielectric bushings 22 which insulate them from the hinge leaves 14 and 16 and from one another. Thus, the hinge 10 when closed can complete four different electrical paths or lines.

The contactors 20a, b of the contact hinge 10 are connected with an alarm A such that alarm A will be actuated when the contactors 20a, b are separated from their respective contacts 18a, b, thereby breaking an electrical circuit through the contacts 18a, b and contactors 20a, b. The alarm A is located in a security office or at some other place remote from the door D. During normal business hours the alarm A may be deactivated, but after business hours it is set to maintain surveillance over the door D. Thus, when the door D is opened, the alarm A will be actuated, provided the alarm A is set to operate.

The lock L is a standard unit-type lock which is modified such that when it is unlocked a switch is activated to temporarily inactivate the alarm A. The lock L includes (FIG. 3) a latch assembly 30 and a pair of knob assemblies 32 and 34.

The latch assembly 32 (FIGS. 3 and 4) is located in the door D directly opposite from the keeper 12 and has a face plate 36 which is set into the edge of the door D such that its outside face is flush with the edge surface of the door D. Fastened to the face plate 36 and projected into the door D therefrom is a bolt housing 38 which houses a spring loaded latch bolt 40. When the door D is closed, the latch bolt 40 aligns with and projects into the apertured keeper 12 or the strike jamb 4, and the spring loading is such that the latch bolt 40 is urged outwardly beyond the face plate 38. Thus, unless retracted, the latch bolt 40 will prevent the door D from opening. Projected in the opposite direction from the housing 38 are a pair of guide plates 42 joined at their ends by spaced apart connecting portions 44 (FIG. 4). Between the guide plates 42 is an actuating stem 46 which is somewhat shorter than the guide plates 42 and projects into the bolt housing 38 where it interlocks with latch bolt 40. The connection is such that the actuating stem 46, when moved toward the

42, will draw the latch bolt 40 into the housing 38 a sufficient distance to enable the latch bolt 40 to be withdrawn completely from the keeper 12. Nevertheless, the connection permits independent movement of the latch bolt 40 with respect to the actuating stem 46 so that the bolt 40 can be depressed into the housing 38 upon striking the keeper 12, without causing the actuating stem 46 to move toward the connecting portions 44 on the guide plates 42. The actuating stem 46 is provided with a noncircular aperture 48 having generally vertical margins at its upper and lower ends.

Attached to the ends of the guide plates 42 located remote from the bolt housing 38 is a switch housing 50 (FIGS. 3 and 4) containing a switch 52 which has an operating blade 54 located in the path of the actuating stem 46. The blade 54 is positioned such that when the activating stem 46 is moved far enough to retract the latch bolt 40 from the keeper 12, the actuating stem 46 will also engage the blade 54 and cause it to close the switch 52. The switch 52 is connected to the alarm A through the contacts 18c and 18d and the corresponding contactors 20c and 20d of the contact hinge 10 (FIG. 2). When closed, the switch 52 triggers a time delay in the alarm A, and this time delay deactivates the alarm A for a short interval of time, such as 20 seconds. Thus, during this interval the door D may be opened without setting off the alarm A.

The knob assembly 32 (FIG. 3) includes a circular mounting plate 60 which is fastened firmly against one face of the door D. The plate 60 carries a handle or knob 62 which is capable of rotating in the plate 60, and the knob 62 has an operating spindle 64 secured firmly to it. The spindle 64 projects through the noncircular aperture 48 in the actuating stem 46 and has a pair of longitudinally extending edges positioned adjacent to the upper and lower vertical margins of the aperture 48. Thus, when the spindle 64 is rotated in either direction by turning the knob 62, the actuating stem 46 is driven toward the hinge jamb 6 and the latch bolt 40 is withdrawn from the keeper 12. The knob 62 and its spindle 64 coupled with the actuating stem 46 constitute operating means for retracting the latch bolt 40.

The knob 62 contains a locking mechanism 66 (FIG. 3) which is operated by a key 68 and may be moved by key 68 between locked and unlocked positions. When the lock mechanism 66 is in its locked position, it interlocks with the mounting plate 60 and prevents the knob 62 from rotating. When the lock mechanism 66 is in the unlocked position, the knob 62 is free to rotate in the mounting plate 60 and thereby turn the spindle 64.

The knob assembly 34 (FIG. 3) also includes a mounting plate 70 which is fastened against the opposite face of the door D. The mounting plate 70 carries a handle or knob 72 which is capable of rotating relative to the mounting plate 70. The inner end of the knob 72 has a socket which receives the end of the spindle 64 projecting from the other knob 62, the fit being such that the spindle 64 and knob 72 will rotate together so that when one is turned, the other is also. The knob 72 contains an operating disk 74 which is connected with the lock mechanism 66 in the knob assembly 32 and when turned will move the lock mechanism 66 between its locked and unlocked positions.

Aside from the switch housing 50, and the switch 52 housed therein, the lock L is a conventional unit-type lock, with the one illustrated being currently sold under

## OPERATION

When security precautions are in effect, the alarm A is set such that when the alarm circuit through the contacts 18a, b of the contact hinge 10 is broken, the alarm A will be activated and will thereby signal a security violation at the door D. The alarm circuit is, of course, broken by opening the door D for then the contactors 20a, b will separate from their respective contacts 18a, b. Consequently, anyone opening the door D when security precautions are in effect will set off the alarm A, provided the alarm A is not temporarily deactivated.

Authorized personnel, that is anyone possessing a key 68 which fits the lock mechanism 66, may pass through the door D without activating the alarm A. In particular, when the proper key 68 is inserted into the lock mechanism 66 and turned to move the lock mechanism 66 to its unlocked position, the knob 62 may then be turned to withdraw the latch bolt 40 from the keeper 12 and thereby release the door D from the strike jamb 4. Before the latch bolt 40 is completely withdrawn from the keeper 12, that end of the activating stem 46 located remote from the latch bolt 40 will engage the operating blade 54 of the switch 52 and close the switch 52. Since the switch 52 is connected to the alarm A through the engaged contacts 18c, d and contactors 20c, d of the contact hinge, the completion of the deactivating circuit results in a signal at the alarm A, and this signal deactivates the alarm A for a prescribed duration of time. Usually the alarm A is deactivated just long enough for a person to open the door D, pass through the door opening, and then close the door D.

Consequently, authorized personnel can open the door D without any inconvenience whatsoever, even when the alarm A is set to detect security violations.

**MODIFICATION** The present invention may also be utilized with more sophisticated security systems such as the one disclosed in U.S. patent application, Ser. No. 296,561, filed Oct. 11, 1972 by Francis C. Peterson. In that security system a standard mortise lock provided with an auxiliary latch is modified such that it may be monitored and operated from a remote location. However, once the alarm system is set, the door secured by the lock cannot be opened even by authorized personnel, without setting off the alarm. By incorporating the principal of the present invention into the lock, the foregoing problem is overcome. Sometimes separate key operated switches are provided in these systems for deactivating the alarm long enough to permit passage through the door opening.

In the modified security system (FIGS. 5 and 6) the door D is provided with a mortise lock M having a case 80 and a face plate 82 across the front of the case 80. Projecting from the face plate 82 for entry into the keeper 12 on the strike jamb 4 is a spring loaded latch bolt 84 which moves between retracted and extended positions, but is urged toward its extended position by a spring 85. The face plate 82 also has an auxiliary latch 86 projecting from it, and the auxiliary latch 86 controls the position of a locking lever 88. The auxiliary latch 86 is urged to an outwardly projecting position and assumes this position when the door D is open. In

# Explore Litigation Insights

Docket Alarm provides insights to develop a more informed litigation strategy and the peace of mind of knowing you're on top of things.

## Real-Time Litigation Alerts



Keep your litigation team up-to-date with **real-time alerts** and advanced team management tools built for the enterprise, all while greatly reducing PACER spend.

Our comprehensive service means we can handle Federal, State, and Administrative courts across the country.

## Advanced Docket Research



With over 230 million records, Docket Alarm's cloud-native docket research platform finds what other services can't. Coverage includes Federal, State, plus PTAB, TTAB, ITC and NLRB decisions, all in one place.

Identify arguments that have been successful in the past with full text, pinpoint searching. Link to case law cited within any court document via Fastcase.

## Analytics At Your Fingertips



Learn what happened the last time a particular judge, opposing counsel or company faced cases similar to yours.

Advanced out-of-the-box PTAB and TTAB analytics are always at your fingertips.

## API

Docket Alarm offers a powerful API (application programming interface) to developers that want to integrate case filings into their apps.

## LAW FIRMS

Build custom dashboards for your attorneys and clients with live data direct from the court.

Automate many repetitive legal tasks like conflict checks, document management, and marketing.

## FINANCIAL INSTITUTIONS

Litigation and bankruptcy checks for companies and debtors.

## E-DISCOVERY AND LEGAL VENDORS

Sync your system to PACER to automate legal marketing.