

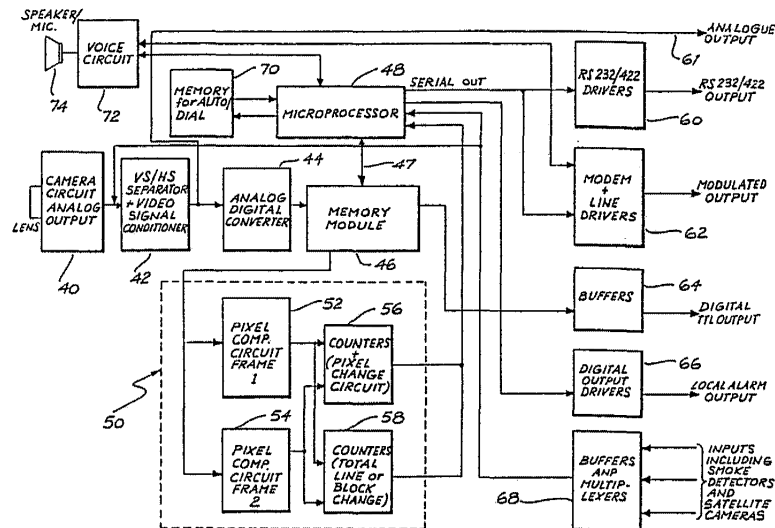

INTERNATIONAL APPLICATION PUBLISHED UNDER THE PATENT COOPERATION TREATY (PCT)

<p>(51) International Patent Classification⁴ : G06F 15/64, 15/70</p>	<p>A1</p>	<p>(11) International Publication Number: WO 88/ 04082 (43) International Publication Date: 2 June 1988 (02.06.88)</p>
<p>(21) International Application Number: PCT/AU87/00383 (22) International Filing Date: 16 November 1987 (16.11.87) (31) Priority Application Number: PH 9145 (32) Priority Date: 25 November 1986 (25.11.86) (33) Priority Country: AU (71) Applicant (for all designated States except US): ZONE TECHNOLOGY PTY. LIMITED [AU/AU]; Suite 7, 41-45 Rickard Road, Bankstown, NSW 2220 (AU). (72) Inventors; and (75) Inventors/Applicants (for US only) : AKNAR, Atila [TR/AU]; 87A Harrow Road, Auburn, NSW 2144 (AU). SOUSSA, Andre [AU/AU]; 23/6 Horner Avenue, Mascot, NSW 2020 (AU). (74) Agents: MAXWELL, Peter, Francis et al.; Halford & Maxwell, Level 20, National Mutual Centre, 44 Market Street, Sydney, NSW 2000 (AU).</p>		<p>(81) Designated States: AT (European patent), AU, BE (European patent), BR, CH (European patent), DE (European patent), DK, FI, FR (European patent), GB, GB (European patent), HU, IT (European patent), JP, KP, KR, LU (European patent), MC, NL (European patent), NO, RO, SE (European patent), SU, US. Published <i>With international search report.</i></p>

(54) Title: DIGITAL IMAGE ACQUISITION SYSTEM



(57) Abstract

A dynamic random access memory (RAM) image sensor (80) in co-operation with driver/de-scramble circuitry (88), microprocessor (84) and grey level difference controller (85) provides a digital image having, for example, a 32 grey level resolution. The digital image can be processed by pixel comparator (86) and microprocessor (84) to detect changes between image frames, for example, to indicate motion of an object. The comparator (86) can operate at real time rates, e.g. 50 frames/second. The result of such detected changes and/or the image can then be transmitted through interfaces (90), (92), (94), (96) or (98) while interface (100) provides communication of external sources with the camera. Bidirectional voice communication is also possible through the interfaces (90)-(100) in analogue or digital format with voice circuit (72) and speaker/microphone (74). This provides a camera with "inbuilt" processing capabilities providing autonomy. The camera can then be incorporated into a system having at least one camera, at least one base station and a communication link connecting the camera and base station.

FOR THE PURPOSES OF INFORMATION ONLY

Codes used to identify States party to the PCT on the front pages of pamphlets publishing international applications under the PCT.

AT Austria	FR France	ML Mali
AU Australia	GA Gabon	MR Mauritania
BB Barbados	GB United Kingdom	MW Malawi
BE Belgium	HU Hungary	NL Netherlands
BG Bulgaria	IT Italy	NO Norway
BJ Benin	JP Japan	RO Romania
BR Brazil	KP Democratic People's Republic of Korea	SD Sudan
CF Central African Republic	KR Republic of Korea	SE Sweden
CG Congo	LI Liechtenstein	SN Senegal
CH Switzerland	LK Sri Lanka	SU Soviet Union
CM Cameroon	LU Luxembourg	TD Chad
DE Germany, Federal Republic of	MC Monaco	TG Togo
DK Denmark	MG Madagascar	US United States of America
FI Finland		

DIGITAL IMAGE ACQUISITION SYSTEMTECHNICAL FIELD

The present invention relates to an imaging system, and in particular to an imaging system employing an "intelligent" camera. The intelligent camera can be used with a dynamic RAM acting as an image sensor. The dynamic RAM image sensor enables a fully digital system to be implemented.

There are a variety of situations in which an imaging system can be employed. These range from security systems through to robotic systems. In general any imaging system in which an image needs to be transmitted to a central or alternative location can employ the present invention.

BACKGROUND ART

In known systems, for example closed circuit television systems, a camera unit such as a vidicon captures the image and then transmits it in analogue form to a station via coaxial cable. Any processing that needs to be performed is usually done at the station. This is at a normally remote central location where with the provision of an analogue to digital converter (ADC) and computer any necessary processing functions are performed. The output from the camera may also be converted into digital form before being transmitted over the communication link. The bandwidth of the communication link places a further limitation and expense on this type

of system.

It is also known to use motion detection software or hardware in security systems to indicate the presence of an intruder or of some disturbance in a given observed space. These know systems generally employ a remote camera which communicates via a communication link with a central observation and processing facility. The central processing facility performs the motion detection with a computer. The communication bandwidth required between the camera and the facility may need to be of the order of several MHz to provide analysis in real time as required for these types of situations. In addition available cameras only provide an analogue output requiring an analogue to digital converter to provide the digital format needed for processing by the computer.

A known imaging device which provides a digital output is a dynamic RAM having a transparent window as disclosed in US patent specification 4441125 to Parkinson. This image sensor uses the light sensitive semi-conductor memory elements of the dynamic RAM to provide a black and white image or it can be employed to provide a variable grey scale output. This image sensor has been described for use in low cost applications such as robots and toys. It is much cheaper and of small size compared with other imaging devices such as vidicons and CCDs (charged coupled devices). The Parkinson specification describes various modes for operating the dynamic RAM as an image sensor. The sensitivity of the sensor can be controlled by varying the rate of scanning of the array or by changing the

threshold value for the determination of the logic state of the cells of the RAM. By scanning the cells with a threshold value which follows a repeating sequence of voltage steps shades of grey can be determined for an
5 image. This can also be achieved by scanning the cell arrays at various rates (periods).

DISCLOSURE OF INVENTION

The present invention overcomes the disadvantages in the prior art referred to above by providing a novel
10 method of operating an image sensor employing a dynamic RAM and also an imaging unit employing a camera or imaging device which has associated with the imaging device processing capabilities giving autonomy to the actual imaging device to provide an "intelligent" camera. The
15 intelligent camera can then be employed in a system providing intelligent bi-directional communication with a base station.

In accordance with one aspect of the invention there is provided a method of image acquisition using a dynamic
20 random access memory (RAM) image sensor having a transparent window through which a lens can focus an image on an array of radiation sensitive cells of said dynamic RAM image sensor including the steps of: setting the cells of said dynamic RAM to a fully charged state, scanning the
25 said image sensor to provide a series of images of variable exposure lengths, storing the said series of images of variable exposure lengths in a buffer, and processing said series of images of variable exposure lengths to provide a measure of the difference between

Explore Litigation Insights

Docket Alarm provides insights to develop a more informed litigation strategy and the peace of mind of knowing you're on top of things.

Real-Time Litigation Alerts



Keep your litigation team up-to-date with **real-time alerts** and advanced team management tools built for the enterprise, all while greatly reducing PACER spend.

Our comprehensive service means we can handle Federal, State, and Administrative courts across the country.

Advanced Docket Research



With over 230 million records, Docket Alarm's cloud-native docket research platform finds what other services can't. Coverage includes Federal, State, plus PTAB, TTAB, ITC and NLRB decisions, all in one place.

Identify arguments that have been successful in the past with full text, pinpoint searching. Link to case law cited within any court document via Fastcase.

Analytics At Your Fingertips



Learn what happened the last time a particular judge, opposing counsel or company faced cases similar to yours.

Advanced out-of-the-box PTAB and TTAB analytics are always at your fingertips.

API

Docket Alarm offers a powerful API (application programming interface) to developers that want to integrate case filings into their apps.

LAW FIRMS

Build custom dashboards for your attorneys and clients with live data direct from the court.

Automate many repetitive legal tasks like conflict checks, document management, and marketing.

FINANCIAL INSTITUTIONS

Litigation and bankruptcy checks for companies and debtors.

E-DISCOVERY AND LEGAL VENDORS

Sync your system to PACER to automate legal marketing.