

UNITED STATES PATENT AND TRADEMARK OFFICE

BEFORE THE PATENT TRIAL AND APPEAL BOARD

APPLE INC.,
Petitioner,

v.

CHESTNUT HILL SOUND INC.,
Patent Owner.

Case IPR2015-01463
Patent 8,090,309 B2

Before RAMA G. ELLURU, DAVID C. MCKONE,
and JOHN F. HORVATH, *Administrative Patent Judges*.

ELLURU, *Administrative Patent Judge*.

DECISION
Denying Institution of *Inter Partes* Review
37 C.F.R. § 42.108

I. INTRODUCTION

Apple, Inc. (“Petitioner”) filed a Petition (Paper 2, “Pet.”) to institute an *inter partes* review of claims 1–14 of U.S. Patent No. 8,090,309 B2 (Ex. 1001, “the ’309 patent”). Chestnut Hill Sound Inc. (“Patent Owner”) filed a Preliminary Response (Paper 8, “Prelim. Resp.”).

Under 35 U.S.C. § 314(a), an *inter partes* review may be instituted only if “the information presented in the petition . . . shows that there is a reasonable likelihood that the petitioner would prevail with respect to at least 1 of the claims challenged in the petition.” 37 C.F.R. § 42.108(c).

For the reasons given below, on this record we find that Petitioner has not established a reasonable likelihood of prevailing with respect to at least one challenged claim of the ’309 patent. Accordingly, we deny the Petition and decline to institute an *inter partes* review of the ’309 patent.

A. *Related Matter*

The ’309 patent is the subject of *Chestnut Hill Sound, Inc. v. Apple Inc.*, Civil Action No. 1:15-cv-00261 (D. Del). Pet. 1; Paper 4, 1.

In addition, a patent resulting from the same application(s) that led to the ’309 patent is involved in IPR2015-01464 and IPR2015-01465. Paper 4, 1. Lastly, Patent Owner asserts that U.S. Application No. 14/243,915 stems from the same application(s) that led to the ’309 patent. *Id.*

B. *The ’309 Patent*

The ’309 patent describes an audio entertainment system. Figures 1 and 2B, reproduced below, illustrate an example:

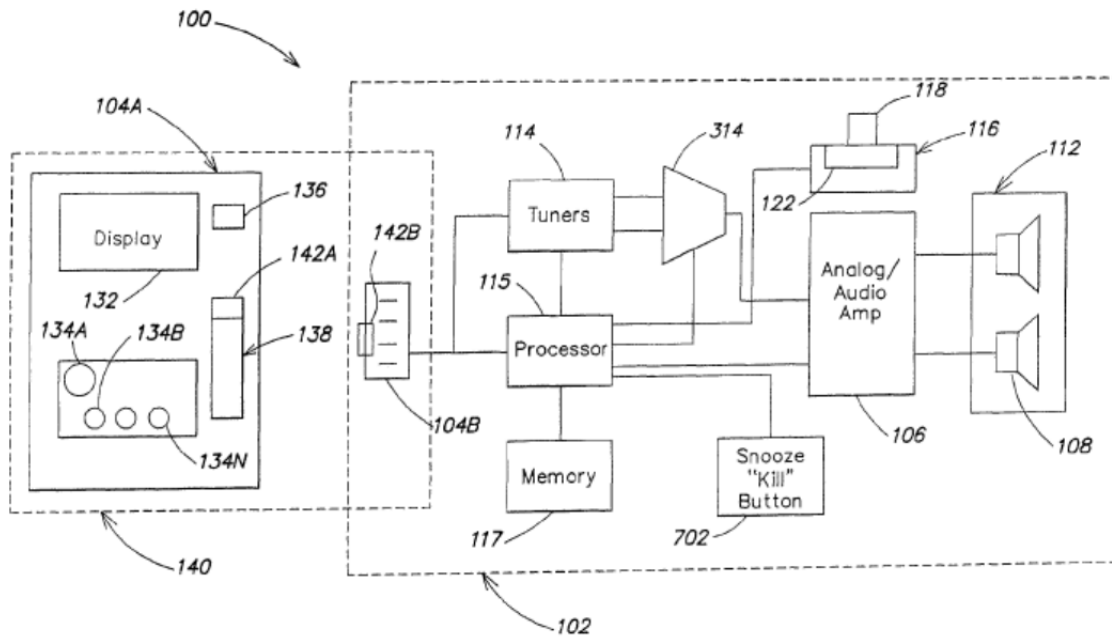

FIG. 1

Figure 1 is a block diagram of an entertainment system. Ex. 1001, 6:33–34, 7:34–36.

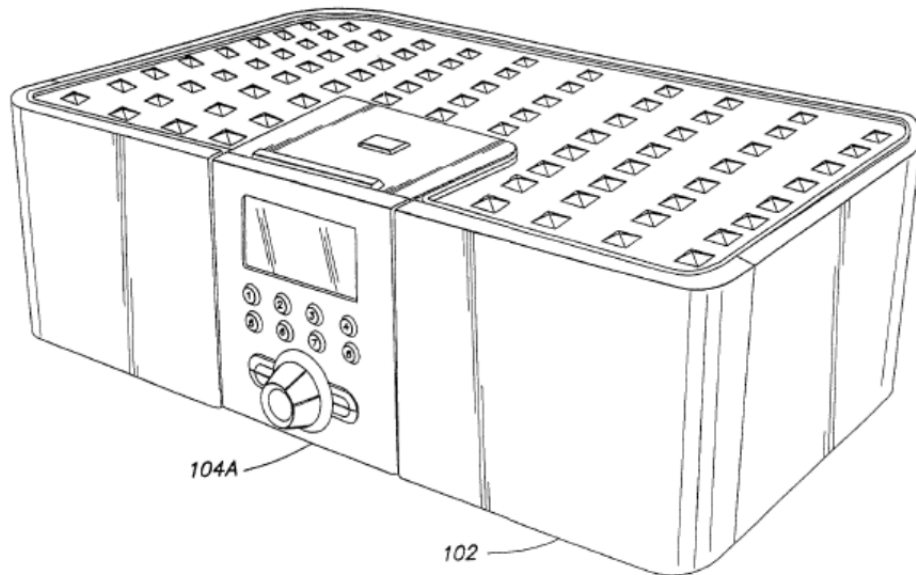

FIG. 2B

Figure 2B is a pictorial view of the entertainment system. *Id.* at 5:37–39.

Entertainment system 100 includes base unit (table unit) 102 and control sub-assembly 104. *Id.* at 3:21–32, 7:34–37. Base unit 102 includes audio amplifier 106, loudspeakers 108, and housing 112. *Id.* at 7:37–40. It also may include tuner 114, and/or audio signal source interface sub-assembly 116 connectable to one or more detachable devices 118 (Auxiliary Source Modules, or “ASMs”). *Id.* at 7:41–43. Detachable device 118 is preferably a digitally controlled device (e.g., “an iPod”) that supplies an audio signal, via the interface sub-assembly 116, to audio amplifier 106. *Id.* at 7:47–57. When the ASM is plugged into the interface sub-assembly, it provides audio signals to the audio amplifier sub-assembly under the control of control sub-assembly 104. *Id.* at 7:58–60.

Control sub-assembly 104 may include a detachable control unit 104A and an interface 104B, in the base unit. *Id.* at 7:44–46. Detachable control unit 104A preferably includes display device 132, input devices 134A–134N, wireless transceiver 136, docking interface port 138, and batteries, in a housing or stand 140 designed to mate with base unit 102. *Id.* at 8:45–49. In a first mode (“docked mode”), control unit 104A is electrically connected to the audio amplifier and signal source electronics sub-assembly via a set of connectors or terminals 142A, 142B, and its wireless transceiver is disabled. *Id.* at 8:58–62. In a second mode (“undocked mode”), the control is separated from the base unit and the electrical connectors 142A, 142B are broken. *Id.* at 9:2–5.

The ’309 patent specification explains that “the system may control a remote device (personal computer, etc.) which can then act as a server of music and other files to the base unit . . . or as a streaming audio source.”

Id. at 8:11–15. In addition, the remote device “may serve up content” from an attached portable music player (e.g., such as an iPod device). *Id.* at 8:25–26. The specification further explains that “the remote device and/or its music source may be controlled via a local control unit such as a detachable control unit 104A.” *Id.* at 8:27–29. “Thus, for example, a user may be in one room of a house with control unit 104A and control the delivery of music from a source in that room, in another room (directly via wireless operation or via a network), or even from a source external to the house.” *Id.* at 8:29–33. To facilitate operation of the control unit and the selection of music to be played, the control unit may operate upon metadata which serves to identify music selections by their source. *Id.* at 8:33–37.

C. Illustrative Claims

Petitioner challenges claims 1–14 of the ’309 patent. Claims 1 and 9 are independent, and claims 2–8 and 10–14 depend, respectively, therefrom. Claim 1 is illustrative of the claimed subject matter and recites the following:

1. A method of using a media device operable in first and second modes, the first mode comprising operation as a system for accessing a media source co-housed with or directly connected to said media device, the source configured to stream media files or media streams for output by said media device, and the second mode comprising operation of the media device as a remote controller system for controlling over a network a media source remote from the media device, comprising:
 - operating the media device in the first mode, wherein when operated in the first mode, the media device performs operations of
 - displaying user-selectable media metadata on a display of the media device, at least one media file or stream being associated with each displayed media metadata

Explore Litigation Insights

Docket Alarm provides insights to develop a more informed litigation strategy and the peace of mind of knowing you're on top of things.

Real-Time Litigation Alerts



Keep your litigation team up-to-date with **real-time alerts** and advanced team management tools built for the enterprise, all while greatly reducing PACER spend.

Our comprehensive service means we can handle Federal, State, and Administrative courts across the country.

Advanced Docket Research



With over 230 million records, Docket Alarm's cloud-native docket research platform finds what other services can't. Coverage includes Federal, State, plus PTAB, TTAB, ITC and NLRB decisions, all in one place.

Identify arguments that have been successful in the past with full text, pinpoint searching. Link to case law cited within any court document via Fastcase.

Analytics At Your Fingertips



Learn what happened the last time a particular judge, opposing counsel or company faced cases similar to yours.

Advanced out-of-the-box PTAB and TTAB analytics are always at your fingertips.

API

Docket Alarm offers a powerful API (application programming interface) to developers that want to integrate case filings into their apps.

LAW FIRMS

Build custom dashboards for your attorneys and clients with live data direct from the court.

Automate many repetitive legal tasks like conflict checks, document management, and marketing.

FINANCIAL INSTITUTIONS

Litigation and bankruptcy checks for companies and debtors.

E-DISCOVERY AND LEGAL VENDORS

Sync your system to PACER to automate legal marketing.