



[54] **METHOD AND APPARATUS CAPABLE OF PRIORITIZING AND STREAMING OBJECTS WITHIN A 3-D VIRTUAL ENVIRONMENT**

[75] Inventor: **David G. Cooper**, Los Gatos, Calif.

[73] Assignee: **Adaptive Media Technologies**, Sunnyvale, Calif.

[21] Appl. No.: **09/054,338**

[22] Filed: **Apr. 2, 1998**

[51] **Int. Cl.**⁷ **G06F 15/00**

[52] **U.S. Cl.** **345/433**

[58] **Field of Search** 345/433, 419, 345/421, 422, 425

[56] **References Cited**

U.S. PATENT DOCUMENTS

- 5,659,691 8/1997 Durward et al. 345/419
- 5,675,721 10/1997 Freedman et al. 345/419

OTHER PUBLICATIONS

Arikawa, M. et al., "Dynamic LoD for QoS Management in the Next Generation VRML," *Proceedings of the Intl. Conf. on Multimedia Computing and Systems*, Jun. 17, 1996.

Funkhouser, T.A. and Sequin, C.H., "Adaptive Display algorithm for Interactive Frame Rates during Visualization of Complex Virtual Environments," *Computer Graphics Proceedings, Annual Conf. Series 1993*, pp. 247-254.

Airey, J.M.; Rohlf, J.H.; Brooks, F.P. Jr.; "Towards Image Realism with Interactive Update Rates in Complex Virtual Building Environments," *Computer Graphics, ACM SIGGRAPH Special Issue on 1990 Symposium on Interactive 3D Graphics*, vol. 24, No. 2, Mar. 1990, pp. 41-50.

Blake, E.H.; "A Metric for Computing Adaptive Detail in Animated Scenes using Object-oriented Programming," *Eurographics '87* Elsevier Science Publishers B.V., Proc. of European Computer Graphics Conf. and Exhibition, Amsterdam, Aug. 24-28, 1987, pp. 295-307.

Brooks, F.P. Jr.; "Walkthrough—A Dynamic Graphics System for Simulating Virtual Buildings," *Abstracts from the 1986 Workshop on Interactive 3d Graphics, Computer Graphics*, vol. 21, No. 1, Jan. 1987, p. 3.

Funkhouser, T.A.; Séquin, C.H., Teller, S.J.; "Management of Large Amounts of Data in Interactive Building Walkthroughs," *ACM SIGGRAPH Special issue on 1992 Symposium on Interactive 3D Graphics*, 11-20.

Primary Examiner—Phu K. Nguyen

Attorney, Agent, or Firm—Pillsbury Madison & Sutro LLP

[57] **ABSTRACT**

A method of assessing objects in a 3D graphical scene provides discovery of the most important objects in that scene from the viewer's perspective at any instant in time. These objects are then queued in priority order and requests for each object's data sent to the server at a rate determined by the available network bandwidth. The importance of each object is recalculated per scene update and new requests are sent out based on these values. Only data requests that can be responded to within the next update cycle are sent, while most request messages are retained. This allows for immediate response to a changing view position, and reduces visual latency, defined as the time that lapses until an object having a data deficit gets that data. Latency is reduced for important objects at the cost of lesser objects. Because important objects are those which contribute most to the visual scene, the overall richness of the scene appears to grow faster than the number of objects received.

18 Claims, 5 Drawing Sheets

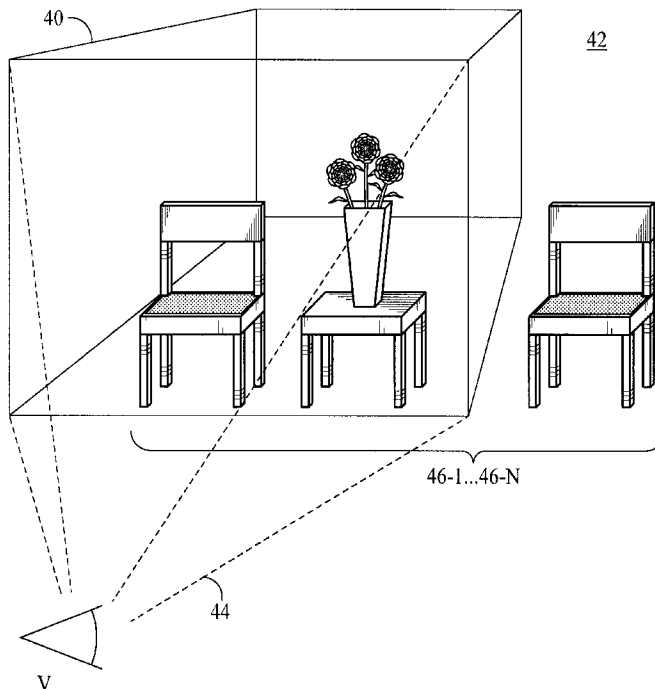

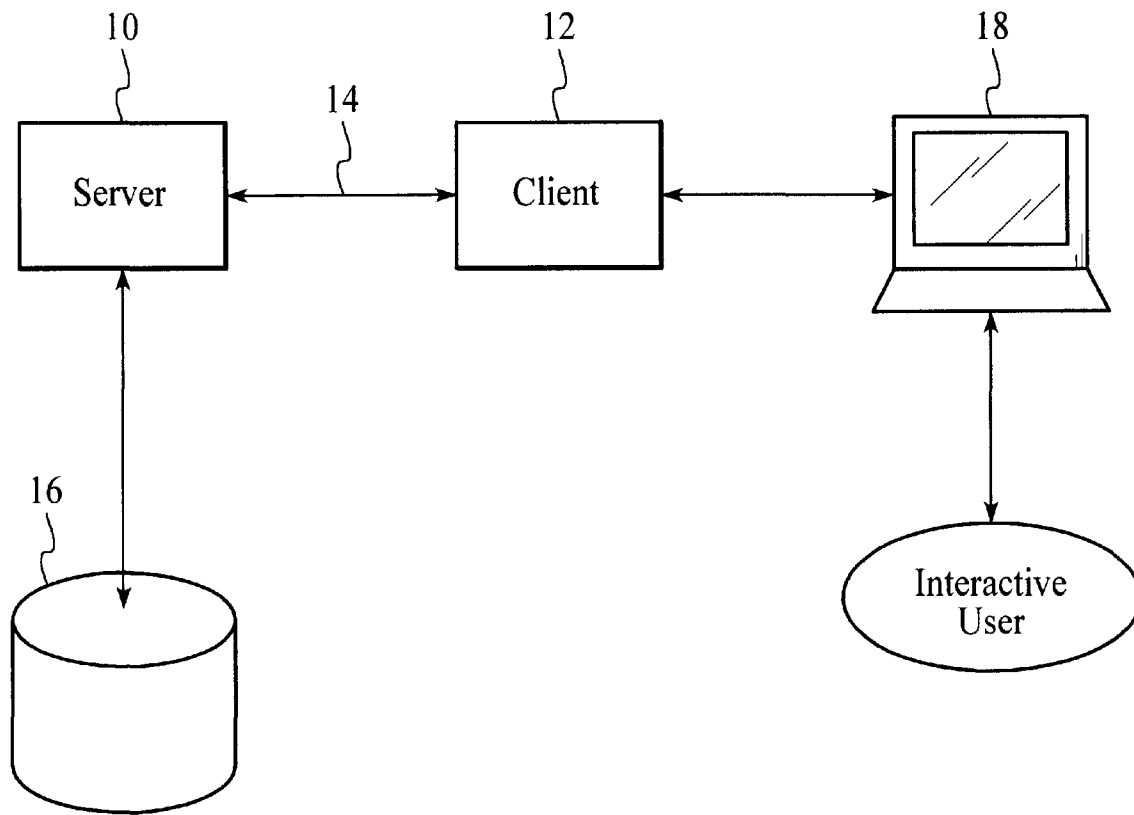

FIG. 1

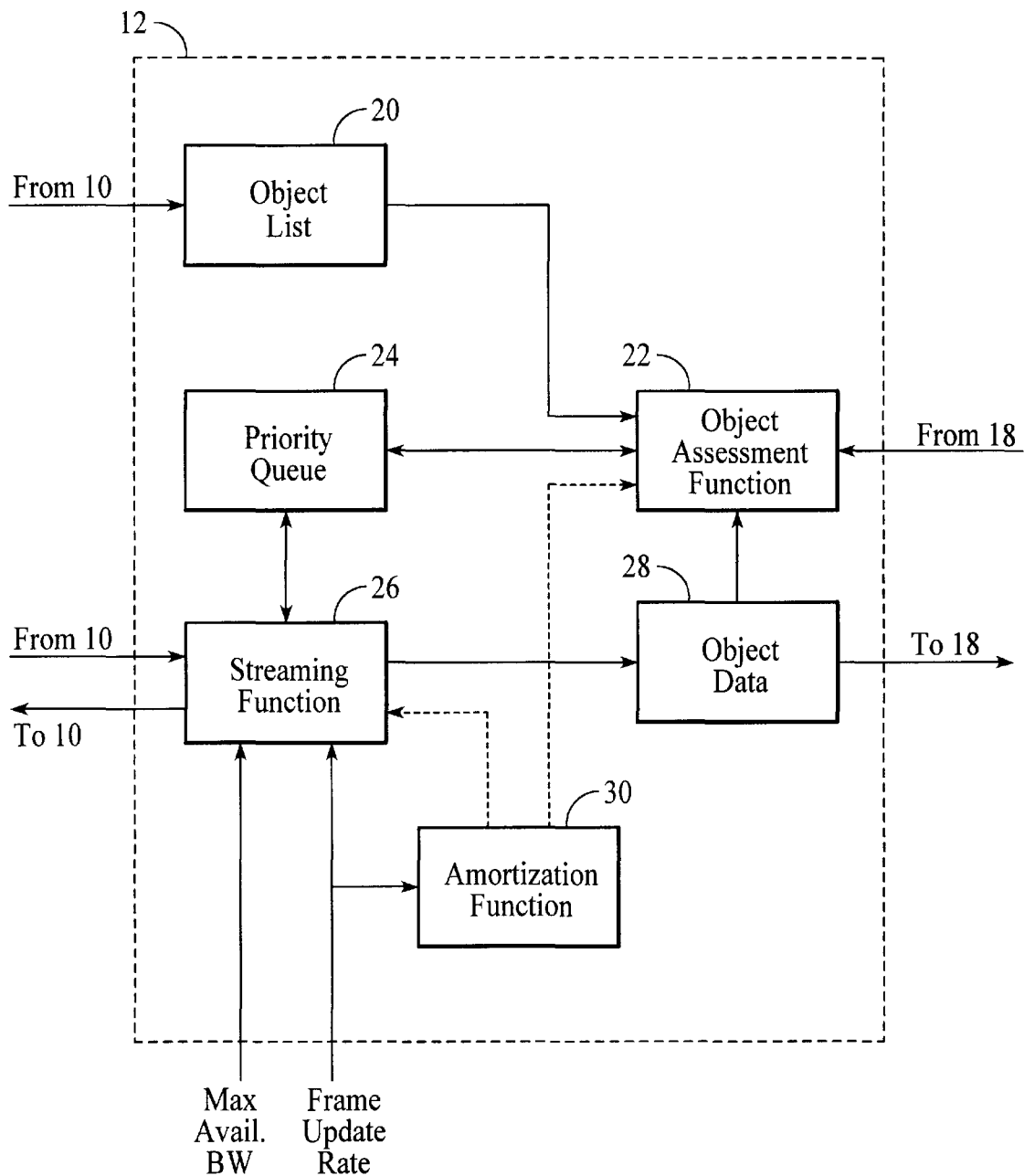

FIG. 2

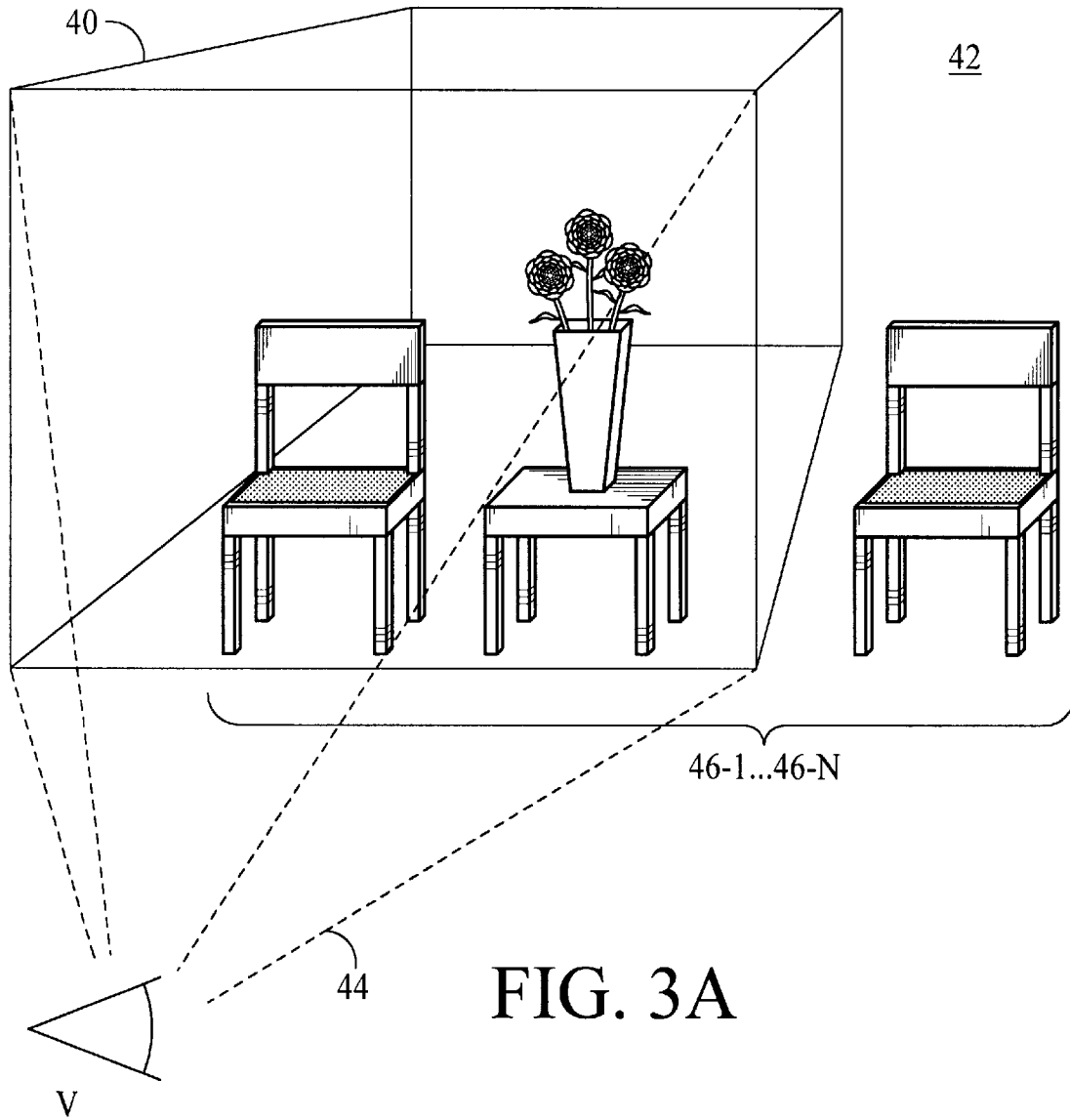

FIG. 3A

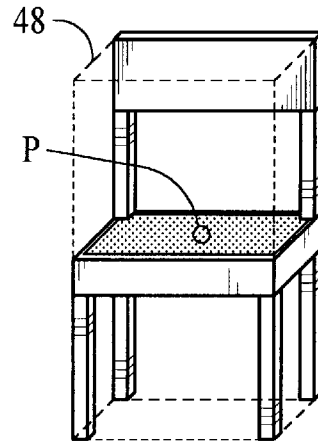

FIG. 3B

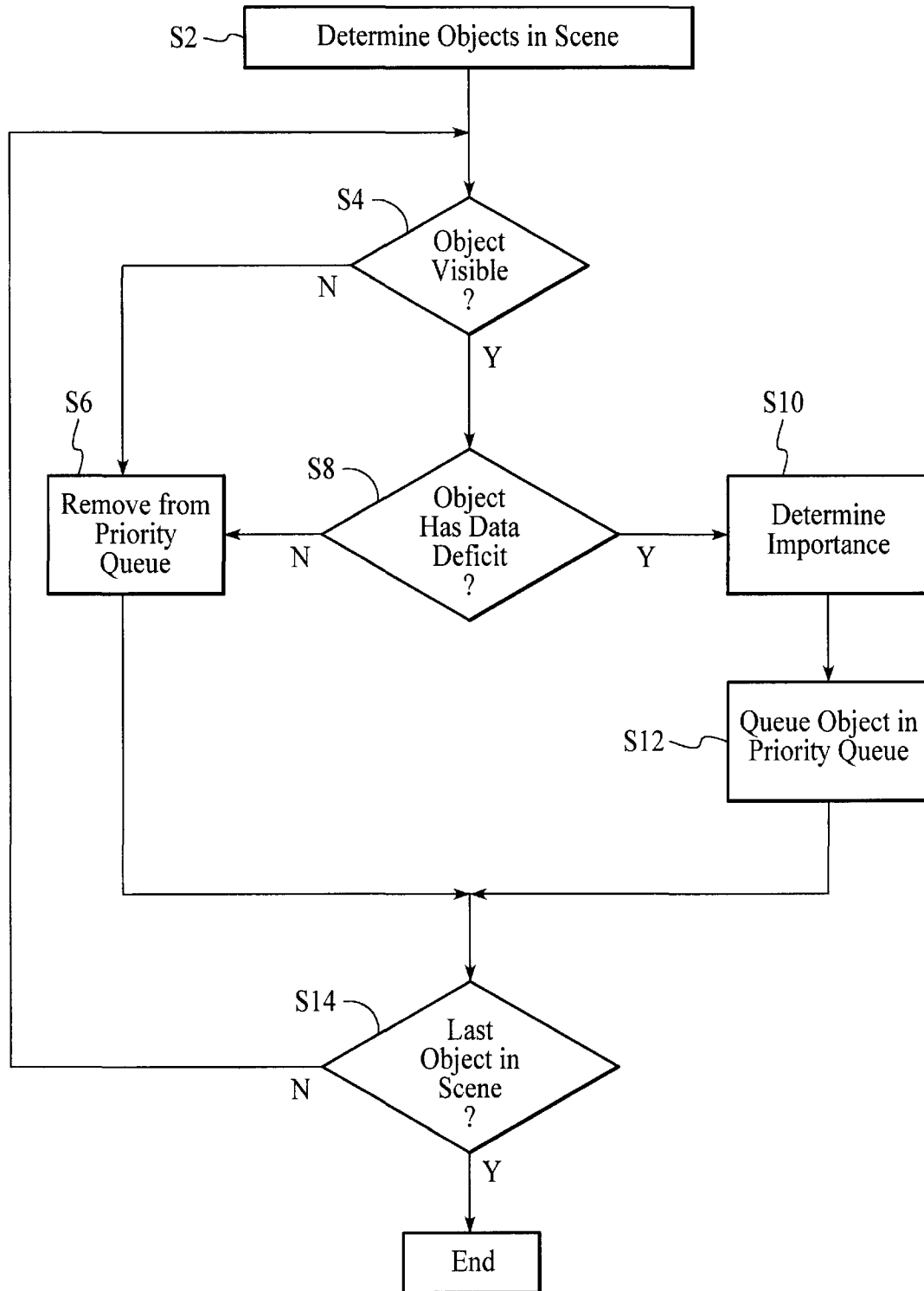

FIG. 4

Explore Litigation Insights

Docket Alarm provides insights to develop a more informed litigation strategy and the peace of mind of knowing you're on top of things.

Real-Time Litigation Alerts



Keep your litigation team up-to-date with **real-time alerts** and advanced team management tools built for the enterprise, all while greatly reducing PACER spend.

Our comprehensive service means we can handle Federal, State, and Administrative courts across the country.

Advanced Docket Research



With over 230 million records, Docket Alarm's cloud-native docket research platform finds what other services can't. Coverage includes Federal, State, plus PTAB, TTAB, ITC and NLRB decisions, all in one place.

Identify arguments that have been successful in the past with full text, pinpoint searching. Link to case law cited within any court document via Fastcase.

Analytics At Your Fingertips



Learn what happened the last time a particular judge, opposing counsel or company faced cases similar to yours.

Advanced out-of-the-box PTAB and TTAB analytics are always at your fingertips.

API

Docket Alarm offers a powerful API (application programming interface) to developers that want to integrate case filings into their apps.

LAW FIRMS

Build custom dashboards for your attorneys and clients with live data direct from the court.

Automate many repetitive legal tasks like conflict checks, document management, and marketing.

FINANCIAL INSTITUTIONS

Litigation and bankruptcy checks for companies and debtors.

E-DISCOVERY AND LEGAL VENDORS

Sync your system to PACER to automate legal marketing.