

UNITED STATES PATENT AND TRADEMARK OFFICE

---

BEFORE THE PATENT TRIAL AND APPEAL BOARD

---

VALEO NORTH AMERICA, INC., VALEO S.A., VALEO GMBH,  
VALEO SCHALTER UND SENSOREN GMBH, and  
CONNAUGHT ELECTRONICS LTD.,  
Petitioner,

v.

MAGNA ELECTRONICS INC.,  
Patent Owner.

---

Cases IPR2015-01410 and IPR2015-01414  
Patent 8,643,724 B2

---

Before JUSTIN T. ARBES, MICHAEL J. FITZPATRICK, and  
ROBERT J. WEINSCHENK, *Administrative Patent Judges*.

ARBES, *Administrative Patent Judge*.

DECISION  
Institution of *Inter Partes* Review  
37 C.F.R. § 42.108

Petitioners Valeo North America, Inc., Valeo S.A., Valeo GmbH, Valeo Schalter und Sensoren GmbH, and Connaught Electronics Ltd. (collectively, “Petitioner”) filed two Petitions requesting *inter partes* review of claims 1–86 of U.S. Patent No. 8,643,724 B2 (Ex. 1001, “the ’724 patent”)<sup>1</sup> pursuant to 35 U.S.C. §§ 311–19. Patent Owner Magna Electronics Inc. filed a Preliminary Response in each proceeding, as listed in the following chart.

Case Number	Challenged Claims	Petition	Preliminary Response
IPR2015-01410	1–6, 10–18, <sup>2</sup> 23, 25, 29–32, 41–43, 46–56, 58, 61, 62, 64–71, 73, 75–82, 84, and 86	Paper 1 (“Pet.”)	Paper 6 (“Prelim. Resp.”)
IPR2015-01414	7–9, 19–22, 24, 26–28, 33–40, 44, 45, 57, 59, 60, 63, 72, 74, 83, and 85	Paper 1 (“-1414 Pet.”)	Paper 7 (“-1414 Prelim. Resp.”)

We have authority under 35 U.S.C. § 314 and 37 C.F.R. § 42.4(a). Pursuant to 35 U.S.C. § 314(a), the Director may not authorize an *inter partes* review unless the information in the petition and preliminary response “shows that there is a reasonable likelihood that the petitioner would prevail with respect to at least 1 of the claims challenged in the petition.” For the reasons that follow, we institute an *inter partes* review as to claims 1, 3–12,

---

<sup>1</sup> Petitioner appears to have filed the same exhibits in each proceeding. References to exhibits herein are to those filed in Case IPR2015-01410.

<sup>2</sup> Petitioner lists claim 19 in its Petition in Case IPR2015-01410, but does not include claim 19 in any asserted ground of unpatentability. See Pet. 1, 6; Prelim. Resp. 1 n.1. Thus, we presume that the initial listing of claims was a typographical error.

14, 15, 17, 19–52, 54–67, 69–79, and 81–86 of the '724 patent on certain grounds of unpatentability. To administer the proceedings more efficiently, we also exercise our authority under 35 U.S.C. § 315(d) to consolidate the two proceedings and conduct the proceedings as one trial.

## I. BACKGROUND

### A. The '724 Patent<sup>3</sup>

The '724 patent relates generally to “rearview vision systems which provide the vehicle operator with scenic information in the direction rearward of the vehicle.” Ex. 1001, col. 1, ll. 22–25. According to the '724 patent, there was a need in the art to “reduce the amount of time spent gathering information [about] the condition around the vehicle in order to safely carry out a vehicle maneuver, such as a turn or a lane change,” and also a need to “eliminate exterior rearview mirrors by utilizing image capture devices, such as cameras, in combination with dashboard displays.” *Id.* at col. 1, ll. 28–59. Prior art camera-based systems typically used more than one camera to reduce blind spots, but displayed multiple images, which could confuse the driver. *Id.* at col. 1, l. 60–col. 2, l. 3. Specifically, “[w]hen multiple image capture devices are positioned at different longitudinal locations on the vehicle, objects behind the vehicle are at

---

<sup>3</sup> Petitioner previously filed petitions seeking *inter partes* review of the '724 patent in Cases IPR2015-00252 and IPR2015-00253. The petitions were denied. *See Valeo N. Am., Inc. v. Magna Elecs., Inc.*, Case IPR2015-00252 (PTAB May 13, 2015) (Paper 7) (“-252 Dec.”); *Valeo N. Am., Inc. v. Magna Elecs., Inc.*, Case IPR2015-00253 (PTAB May 13, 2015) (Paper 7) (“-253 Dec.”). A patent sharing a similar specification with the '724 patent also is challenged in Cases IPR2014-00220 and IPR2014-01203.

different distances from the image capture devices,” such that the same object would have a different size in each display. *Id.* at col. 2, ll. 3–8.

To address these issues, the '724 patent discloses a multi-camera vision system having two image capture devices on the sides of the vehicle and one at the rear of the vehicle, and a reconfigurable display device that displays a synthesized image from the image capture devices. *Id.* at col. 2, l. 59–col. 3, l. 25. Figure 1 of the '724 patent is reproduced below.

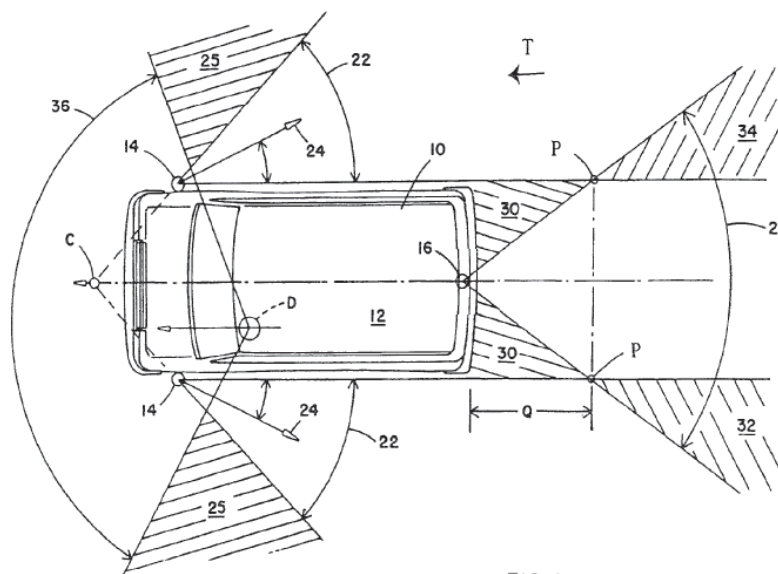

FIG. 1

Figure 1 depicts vehicle 10 traveling in direction T and comprising side image capture devices 14 each with field of view 22 and center image capture device 16 with field of view 26. *Id.* at col. 5, l. 47–col. 6, l. 21. The three captured images are processed and “juxtaposed on display 20 by image processor 18 in a manner which approximates the view from a single virtual image capture device positioned forwardly of the vehicle at a location C and facing rearwardly of the vehicle, with the vehicle being transparent to the view of the virtual image capture device.” *Id.* at col. 5, l. 63–col. 6, l. 2. The resulting display provides a “substantially seamless panoramic view

rearwardly of the vehicle without duplicate or redundant images of objects.”  
*Id.* at col. 6, ll. 2–5.

Figure 3 of the '724 patent is reproduced below.

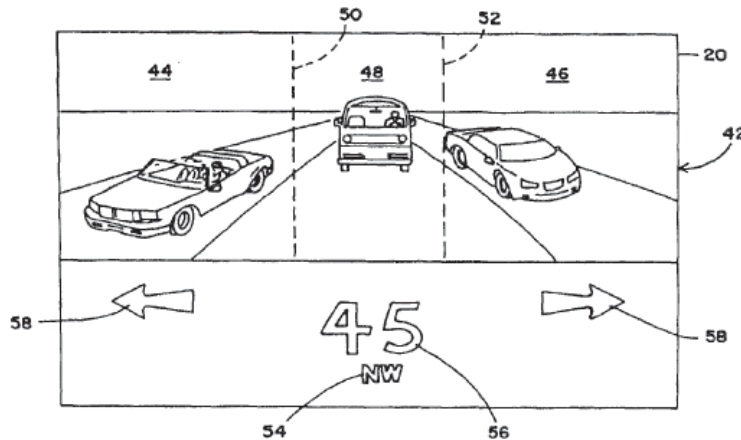

FIG. 3

Figure 3 depicts composite image 42 comprising left image portion 44, right image portion 46, and center image portion 48, reversed from the images captured by the image capture devices, as well as compass readout 54, vehicle speed 56, and turn signals 58. *Id.* at col. 7, l. 44–col. 8, l. 7. Due to the different positioning of side image capture devices 14 and center image capture device 16, the system may process side images differently from the central images (e.g., by vertically compressing the central images) to avoid the appearance of disjointed objects. *Id.* at col. 14, l. 52–col. 16, l. 14.

### *B. Illustrative Claim*

Claim 1 of the '724 patent recites:

1. A multi-camera vision system for a vehicle, said vehicular multi-camera vision system comprising:
  - at least three image capture devices disposed at a vehicle equipped with said vehicular multi-camera vision system;

# Explore Litigation Insights

Docket Alarm provides insights to develop a more informed litigation strategy and the peace of mind of knowing you're on top of things.

## Real-Time Litigation Alerts



Keep your litigation team up-to-date with **real-time alerts** and advanced team management tools built for the enterprise, all while greatly reducing PACER spend.

Our comprehensive service means we can handle Federal, State, and Administrative courts across the country.

## Advanced Docket Research



With over 230 million records, Docket Alarm's cloud-native docket research platform finds what other services can't. Coverage includes Federal, State, plus PTAB, TTAB, ITC and NLRB decisions, all in one place.

Identify arguments that have been successful in the past with full text, pinpoint searching. Link to case law cited within any court document via Fastcase.

## Analytics At Your Fingertips



Learn what happened the last time a particular judge, opposing counsel or company faced cases similar to yours.

Advanced out-of-the-box PTAB and TTAB analytics are always at your fingertips.

## API

Docket Alarm offers a powerful API (application programming interface) to developers that want to integrate case filings into their apps.

## LAW FIRMS

Build custom dashboards for your attorneys and clients with live data direct from the court.

Automate many repetitive legal tasks like conflict checks, document management, and marketing.

## FINANCIAL INSTITUTIONS

Litigation and bankruptcy checks for companies and debtors.

## E-DISCOVERY AND LEGAL VENDORS

Sync your system to PACER to automate legal marketing.