



[54] INTERFERENCE CANCELING METHOD AND APPARATUS

[75] Inventors: Joseph Marash, Haifa; Baruch Berdugo, Kiriat-Ata, both of Israel

[73] Assignee: Lamar Signal Processing, Yokneam, Israel

[21] Appl. No.: 09/157,035

[22] Filed: Sep. 18, 1998

[51] Int. Cl.⁷ H04M 9/08; H03R 3/00

[52] U.S. Cl. 379/410; 379/407; 381/92; 381/94.1; 367/121

[58] Field of Search 379/407, 406, 379/408, 409, 410, 411, 416; 381/92, 94.1, 91.2, 94.7, 155; 367/116, 117, 118, 119-127; 708/322

[56] References Cited

U.S. PATENT DOCUMENTS

4,965,834	10/1990	Miller	381/94.1
5,226,016	7/1993	Christman	367/135
5,627,799	5/1997	Hoshuyama	367/121
5,825,898	10/1998	Marash	381/92

Primary Examiner—Forester W. Isen
Assistant Examiner—Jacques Saint-Surin
Attorney, Agent, or Firm—Frommer Lawrence & Haug LLP; Thomas J. Kowalski

[57] ABSTRACT

Interference canceling is provided for canceling, from a target signal generated from a target source, an interference signal generated by an interference source. The beam splitter beam-splits the target signal into a plurality of band-limited target signals band-limited frequency bands and beam-splits the interference signal into corresponding band-limited frequency bands. The adaptive filter adaptively filters each band-limited interference signal from each corresponding band-limited target signal. The inhibitor can permit the adaptive filter to adapt or change coefficients when a signal-to-noise ratio of the reference signal exceeds a predetermined threshold, to be determined periodically, over a signal-to-noise ratio of the main signal. The beam selector selects at least one of a plurality of beams for adaptive filtering by the adaptive filter representing a direction from which the main signal is received. The beam selector selects beams simultaneously to improve accuracy and, in particular, selects a beam having a fixed direction and a beam which rotates in direction. The noise gate gates the main signal adaptively filtered by the adaptive filter by opening the noise gate when a signal-to-noise ratio at the near end is above a predetermined threshold and closing the noise gate when the signal-to-noise ratio at the near end is below the predetermined threshold. When the target signal represents speech generated at a near end of a teleconference, the adaptive filter cancels an echo present in the reference signal broadcast to a far end of the teleconference.

37 Claims, 7 Drawing Sheets

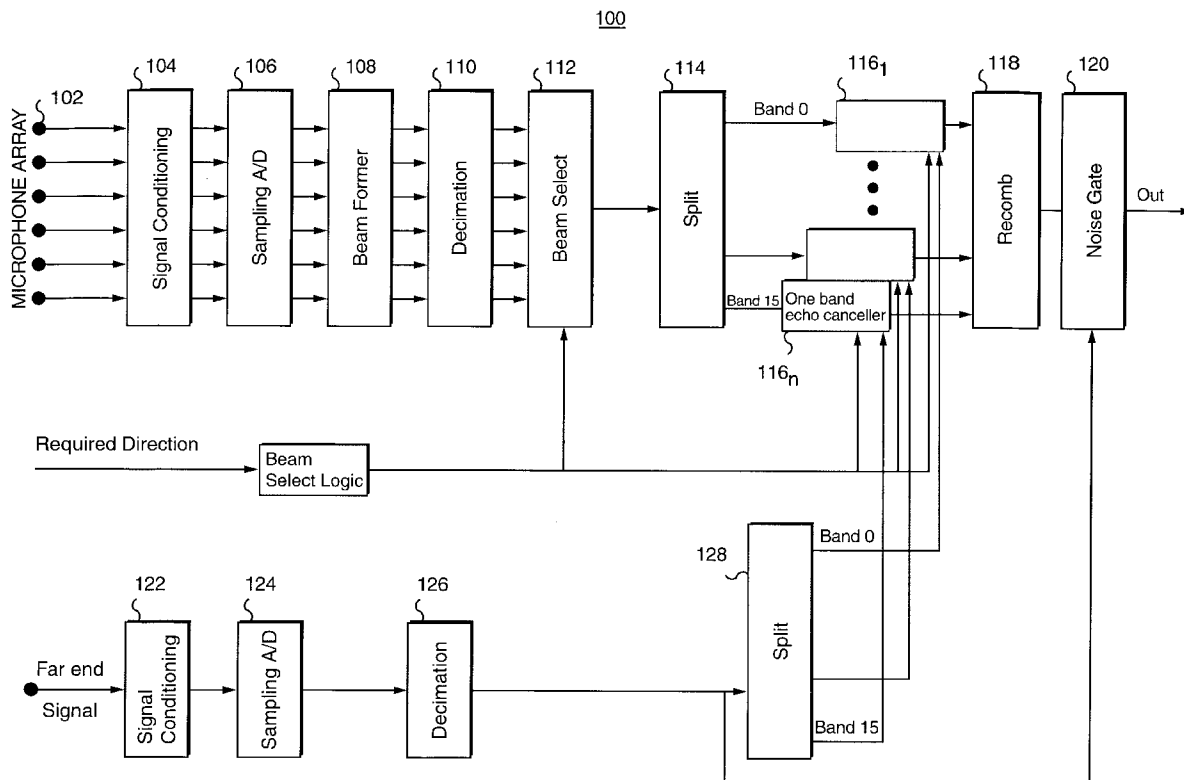

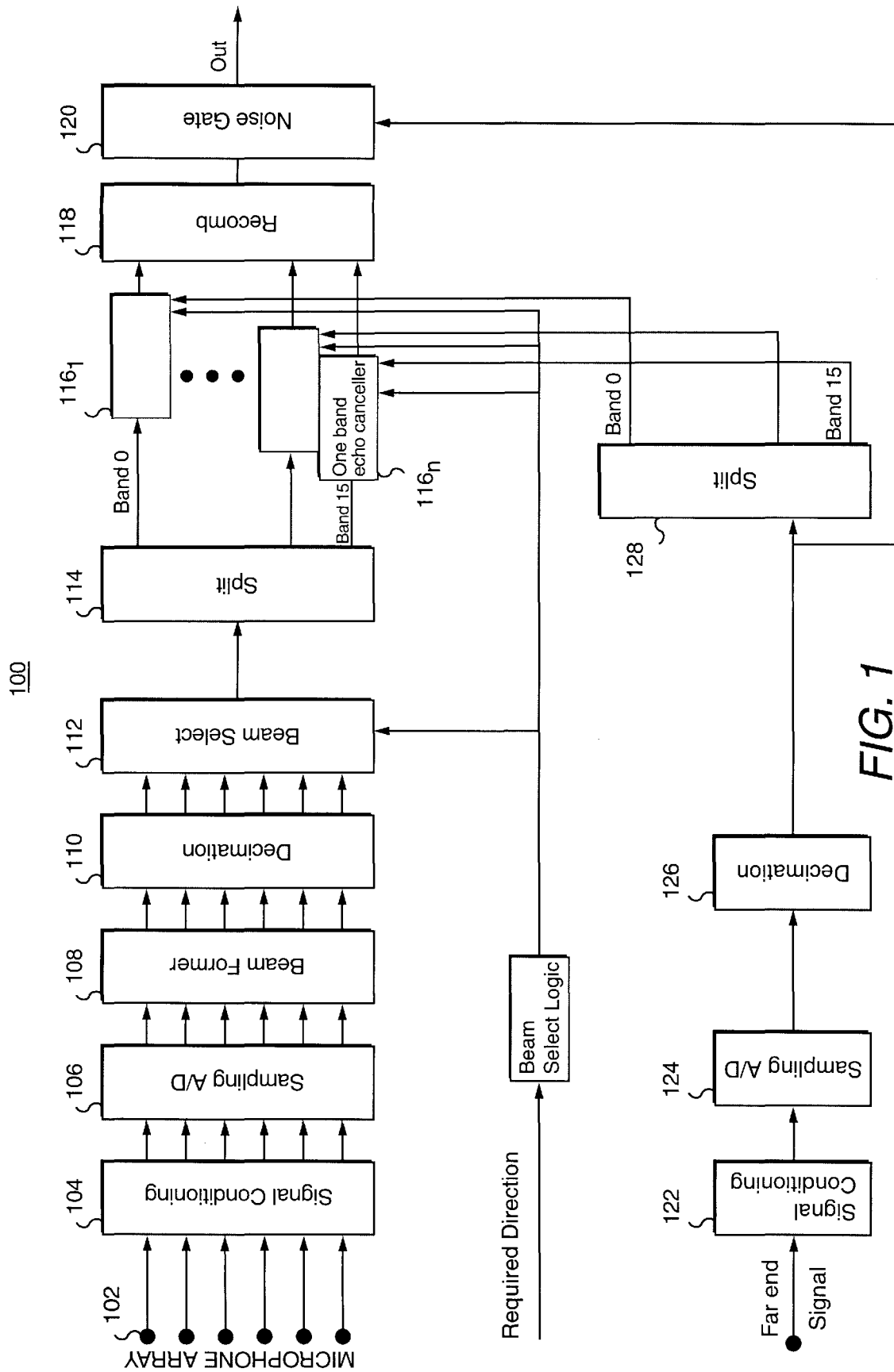

FIG. 1

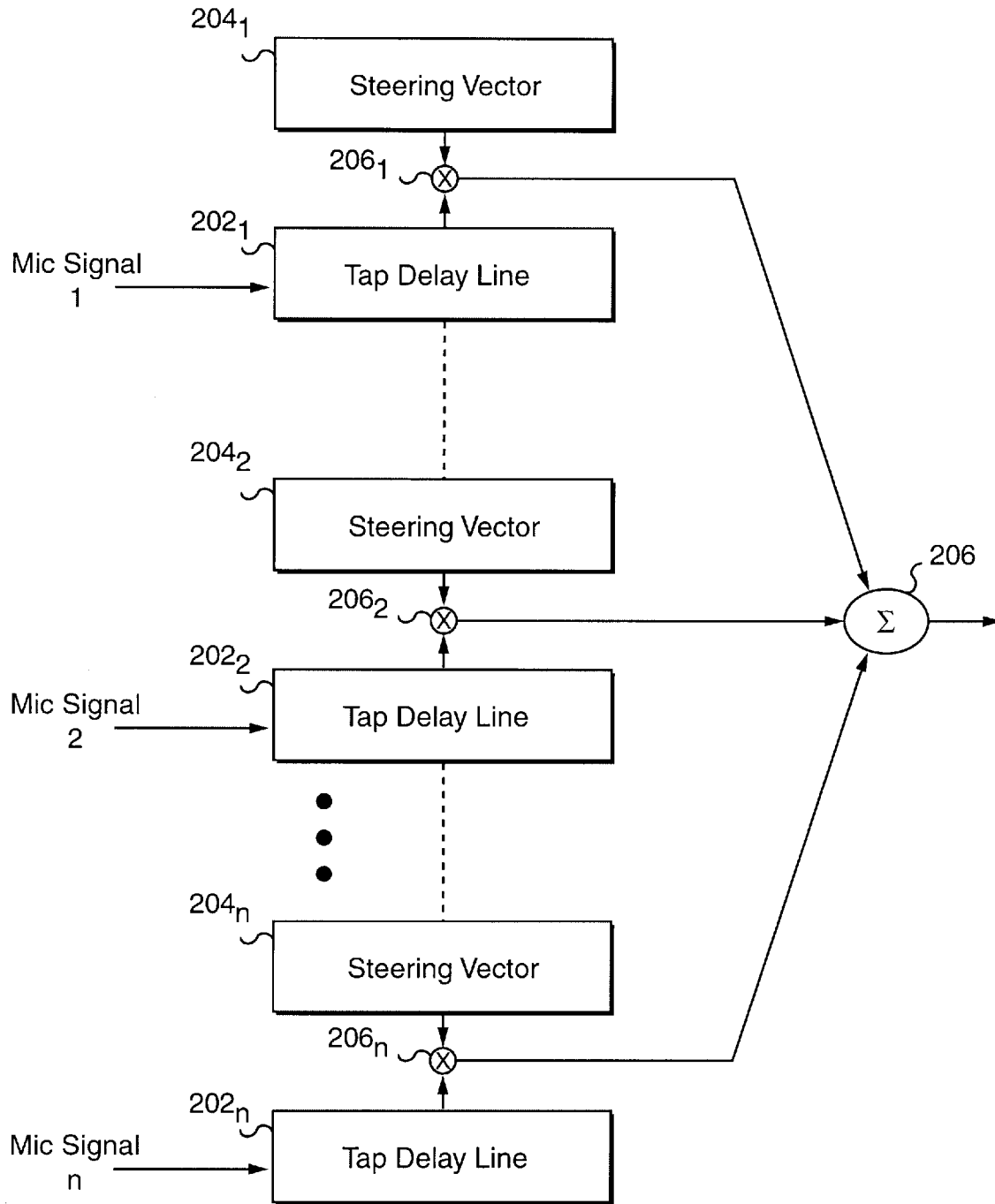
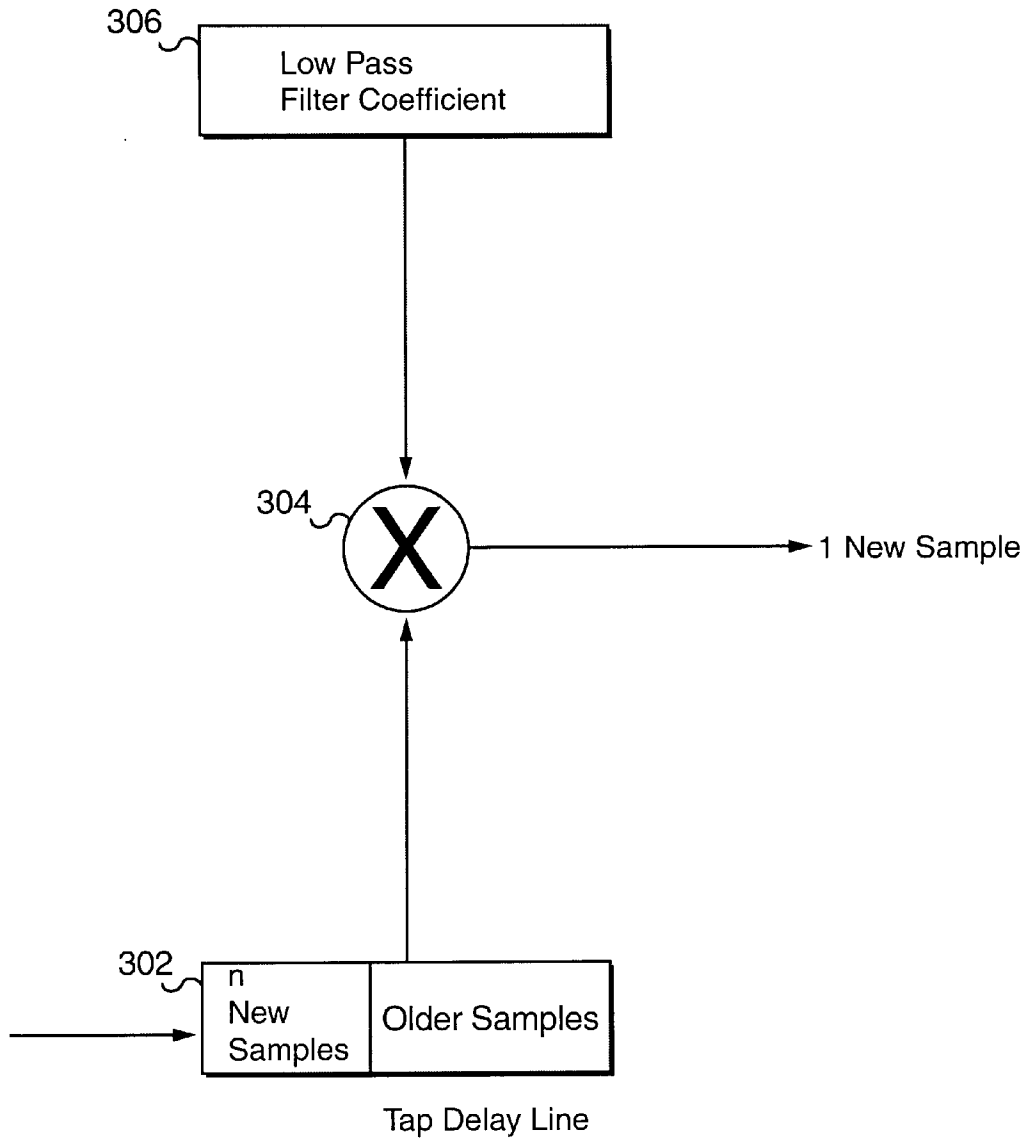

FIG. 2



Decimation by n

FIG. 3

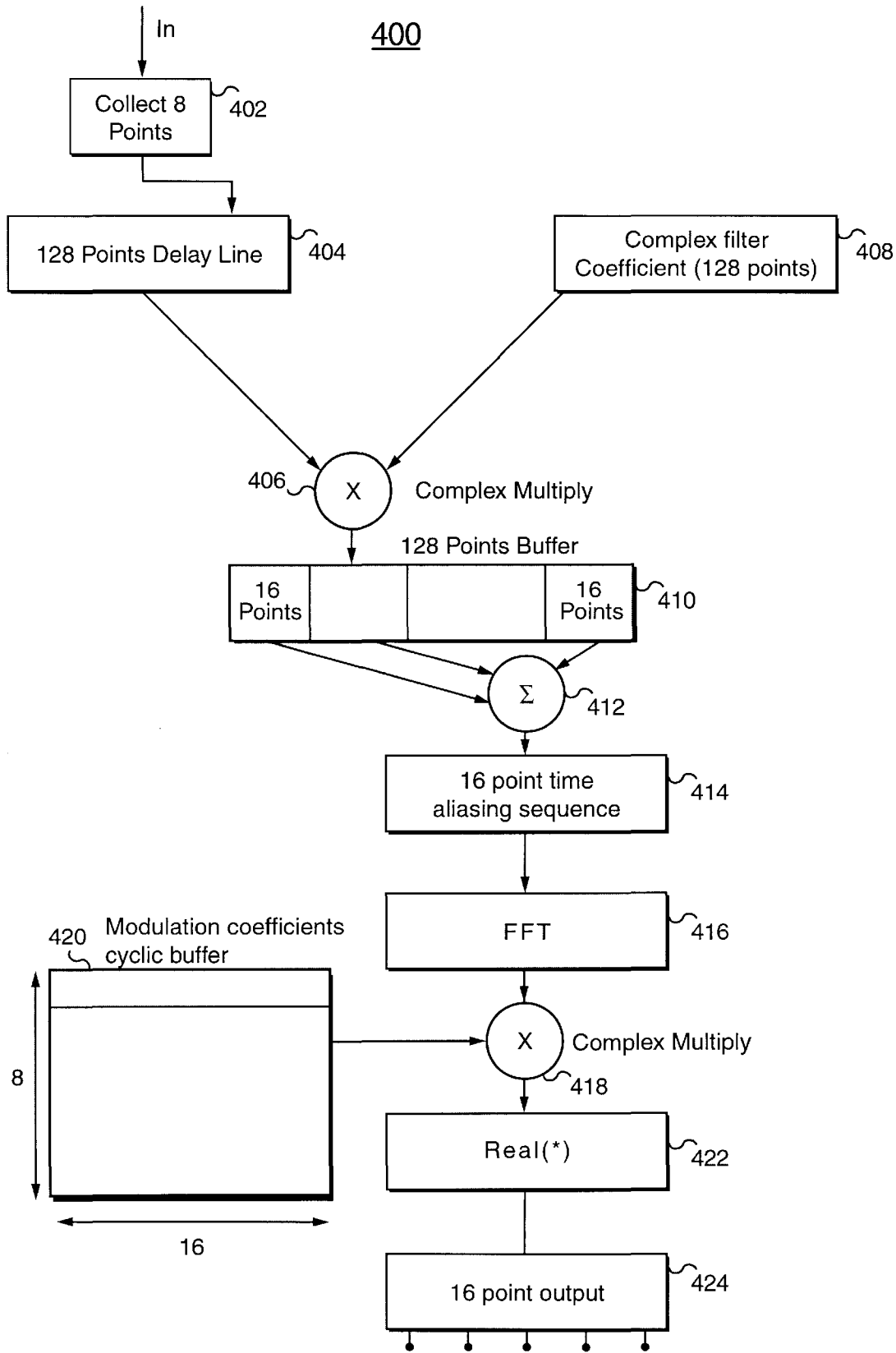

FIG. 4

Explore Litigation Insights

Docket Alarm provides insights to develop a more informed litigation strategy and the peace of mind of knowing you're on top of things.

Real-Time Litigation Alerts



Keep your litigation team up-to-date with **real-time alerts** and advanced team management tools built for the enterprise, all while greatly reducing PACER spend.

Our comprehensive service means we can handle Federal, State, and Administrative courts across the country.

Advanced Docket Research



With over 230 million records, Docket Alarm's cloud-native docket research platform finds what other services can't. Coverage includes Federal, State, plus PTAB, TTAB, ITC and NLRB decisions, all in one place.

Identify arguments that have been successful in the past with full text, pinpoint searching. Link to case law cited within any court document via Fastcase.

Analytics At Your Fingertips



Learn what happened the last time a particular judge, opposing counsel or company faced cases similar to yours.

Advanced out-of-the-box PTAB and TTAB analytics are always at your fingertips.

API

Docket Alarm offers a powerful API (application programming interface) to developers that want to integrate case filings into their apps.

LAW FIRMS

Build custom dashboards for your attorneys and clients with live data direct from the court.

Automate many repetitive legal tasks like conflict checks, document management, and marketing.

FINANCIAL INSTITUTIONS

Litigation and bankruptcy checks for companies and debtors.

E-DISCOVERY AND LEGAL VENDORS

Sync your system to PACER to automate legal marketing.