

# United States Court of Appeals for the Federal Circuit

---

PPC BROADBAND, INC.,  
*Appellant*

v.

CORNING OPTICAL COMMUNICATIONS RF, LLC,  
*Appellee*

---

2015-1361, 2015-1366, 2015-1368, 2015-1369

---

Appeals from the United States Patent and Trade-  
mark Office, Patent Trial and Appeal Board in Nos.  
IPR2013-00340, IPR2013-00345, IPR2013-00346,  
IPR2013-00347.

---

Decided: February 22, 2016

---

J. MICHAEL JAKES, Finnegan, Henderson, Farabow,  
Garrett & Dunner, LLP, Washington, DC, argued for  
appellant. Also represented by ROBERT L. BURNS, II,  
Reston, VA; JUSTIN A. HENDRIX, Palo Alto, CA.

TODD RAY WALTERS, Buchanan Ingersoll & Rooney  
P.C., Alexandria, VA, argued for appellee. Also represent-  
ed by SCOTT LLOYD SMITH, ROGER HYUNGIL LEE.

---

Before MOORE, O'MALLEY, and WALLACH, *Circuit Judges*.

MOORE, *Circuit Judge*.

PPC Broadband, Inc. appeals from the Patent Trial and Appeal Board's ("Board") final written decisions in inter partes reviews ("IPRs") concluding that claims 1–32 of U.S. Patent No. 8,287,320, claims 1–9 of U.S. Patent No. 8,323,060, and claims 7–27 of U.S. Patent No. 8,313,353 would have been obvious. We *vacate* the Board's determination that claims 8, 16, and 31 of the '320 patent, claims 1–9 of the '060 patent, and claims 7–27 of the '353 patent are unpatentable, *affirm* the Board's determination that claims 1–7, 9–15, 17–30, and 32 of the '320 patent are unpatentable, and *remand* for further proceedings.

#### BACKGROUND

A coaxial cable has an inner electrical conductor (often called the "signal" or "signal feed") and an outer electrical conductor (often called the "ground return" or "ground"). Poor or intermittent connections on either conductor can result in noise or non-functionality. The '320 patent family discloses coaxial cable connectors having a connector body 50, a post 40, a nut 30 (also called a "coupler"), and a "continuity member" that contacts the post and the nut so that electrical grounding continuity is extended through the post and the nut. '320 patent col. 2 ll. 3–6, 15–19, 37–41.<sup>1</sup> The '320 patent discloses more than twenty embodiments of continuity members. For example, Figure 13 depicts an embodiment where the continuity member 370 extends underneath the body 50. Figure 17 depicts a continuity member 570 that is sandwiched between the post 40 and the body 50.

---

<sup>1</sup> The '353 patent and the '060 patent are both continuations of the '320 patent. The three patents share the same specification, in relevant part.

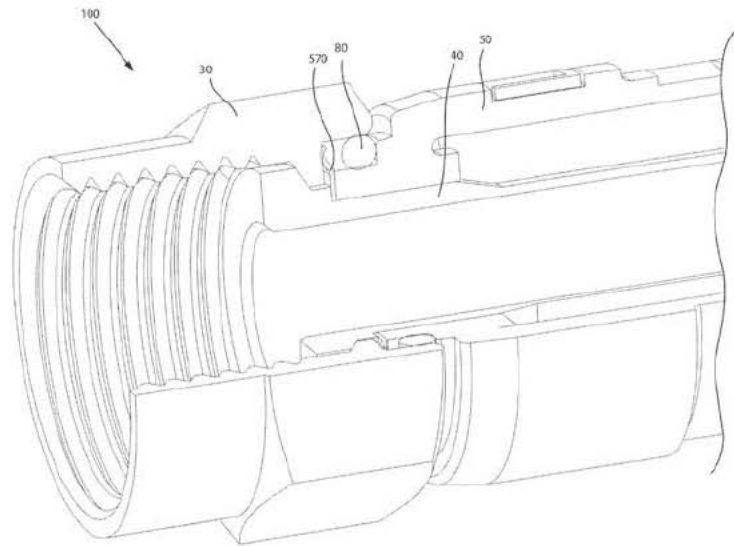

**Figure 17 of the '060 patent:** In this embodiment, the continuity member 570 abuts the face of the body 50.

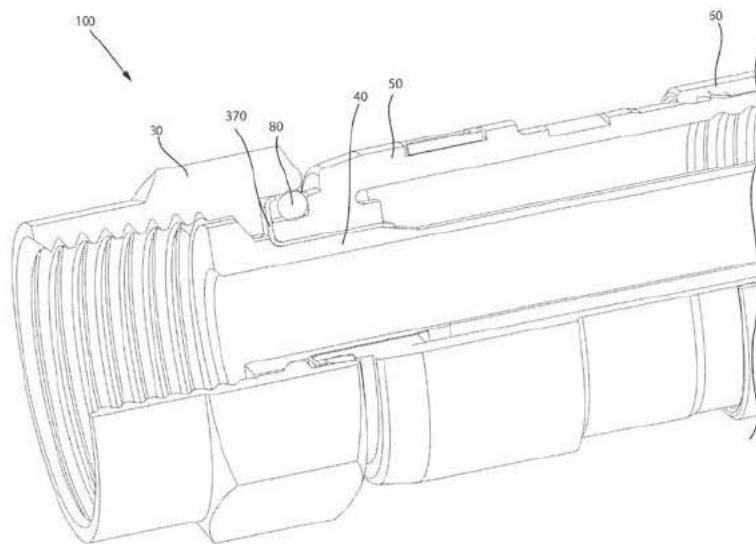

**Figure 13 of the '060 patent:** In this embodiment, the continuity member 370 extends underneath the body 50.

Corning Optical Communications RF, LLC, filed petitions requesting IPRs of claims 1–32 of the '320 patent, claims 1–9 of the '060 patent, and claims 7–27 of the '353 patent on grounds that these claims were unpatentable as obvious over the combination of U.S. published patent application 2006/0110977 (“Matthews”) and Japanese published patent application JP 2002-015823 (“Tatsuzuki”). Between November and December 2013, the Board instituted four separate IPR proceedings.<sup>2</sup>

The Board held a consolidated hearing for the four IPRs in this appeal and issued four separate decisions in which it concluded that all claims at issue would have been obvious. The terms “continuity member” or “electrical continuity member” are present in every claim at issue, and the construction of these terms is central to the Board’s decisions. For example, claim 1 of the '320 patent (emphases added) recites:

1. A coaxial cable connector comprising:
  - a connector body;
  - a post engaged with the connector body, wherein the post includes a flange;
  - a nut, axially rotatable with respect to the post and the connector body, the nut having a first end configured for coupling to an interface port, and an opposing second end, wherein the nut includes an internal

---

<sup>2</sup> Corning also sought, and the Board granted, IPR proceedings on claims 10–25 of the '060 patent. In a separate proceeding, the Board canceled all of these claims as unpatentable for obviousness over the combination of Matthews and Tatsuzuki. PPC Broadband also appealed this decision to this court in Appeal No. 2015-1364.

lip, and wherein the second end portion of the nut starts at a side of the lip of the nut facing the first end of the nut and extends rearward to the second end of the nut;

a *continuity member* disposed only rearward of the start of the second end portion of the nut and contacting the post and the nut, so that the *continuity member extends electrical grounding continuity through the post and the nut*; and

wherein the nut does not touch the connector body, and the continuity member is configured to contact a rearward facing surface of the lip of the nut and extend between a portion of the post and a portion of the connector body.

The Board construed these terms to require “that the continuity member need only make contact with the coupler/nut and the post to establish an electrical connection there,” rather than requiring consistent or continuous contact between the coupler/nut and the post as PPC Broadband argued. J.A. 10, 102, 156, 207.

The Board also construed the terms “shaped to fit” and “configured to fit,” which are present in claims 1–9 of the '060 patent, claims 16 and 24 of the '353 patent, and claim 28 of the '320 patent. The Board held that components or surfaces that are shaped or configured to fit one another “are sized and dimensioned to abut one another,” including components whose surfaces are perpendicular. J.A. 13, 105, 159.

The Board concluded that all claims at issue would have been obvious over the combination of Matthews and Tatsuzuki. The Board considered PPC Broadband's evidence of objective considerations, but determined it did not outweigh the strong evidence of obviousness. PPC

# Explore Litigation Insights

Docket Alarm provides insights to develop a more informed litigation strategy and the peace of mind of knowing you're on top of things.

## Real-Time Litigation Alerts



Keep your litigation team up-to-date with **real-time alerts** and advanced team management tools built for the enterprise, all while greatly reducing PACER spend.

Our comprehensive service means we can handle Federal, State, and Administrative courts across the country.

## Advanced Docket Research



With over 230 million records, Docket Alarm's cloud-native docket research platform finds what other services can't. Coverage includes Federal, State, plus PTAB, TTAB, ITC and NLRB decisions, all in one place.

Identify arguments that have been successful in the past with full text, pinpoint searching. Link to case law cited within any court document via Fastcase.

## Analytics At Your Fingertips



Learn what happened the last time a particular judge, opposing counsel or company faced cases similar to yours.

Advanced out-of-the-box PTAB and TTAB analytics are always at your fingertips.

## API

Docket Alarm offers a powerful API (application programming interface) to developers that want to integrate case filings into their apps.

## LAW FIRMS

Build custom dashboards for your attorneys and clients with live data direct from the court.

Automate many repetitive legal tasks like conflict checks, document management, and marketing.

## FINANCIAL INSTITUTIONS

Litigation and bankruptcy checks for companies and debtors.

## E-DISCOVERY AND LEGAL VENDORS

Sync your system to PACER to automate legal marketing.