

**Broussard v. Go-Devil Mfg. Co.**

United States District Court for the Middle District of Louisiana

July 9, 2014, Decided

CIVIL ACTION NO.: 3:08-cv-00124-BAJ-RLB LEAD CASE; 3:08-cv-00125-BAJ-RLB

**Reporter**

29 F. Supp. 3d 753; 2014 U.S. Dist. LEXIS 94352; 2014 WL 3377708

KYLE BROUSSARD, ET AL. versus GO-DEVIL MANUFACTURING CO. OF LA., INC. D/B/A GO-DEVIL MANUFACTURERS OF LOUISIANA, INC.

Defendants: Joel W. Mohrman, LEAD ATTORNEY, PRO HAC VICE, Anderson L. Cao, PRO HAC VICE, McGlinchey Stafford- Houston, Houston, TX; Juston M. O'Brien, McGlinchey Stafford PLLC, Baton Rouge, LA.

**Subsequent History:** Affirmed by Gator Tail, LLC v. Mud Buddy LLC, 2015 U.S. App. LEXIS 10431 (Fed. Cir., June 22, 2015)

For Mud Buddy L.L.C., doing [\*\*2] business as Mud Buddy Manufacturing (3:08-cv-00125-BAJ-RLB), Defendant: Samuel C. Straight, LEAD ATTORNEY, PRO HAC VICE, R. Layne Royer, Ltd., Baton Rouge, LA; Allen D. Darden, Phelps Dunbar, LLP, Baton Rouge, LA; Jed H. Hansen, PRO HAC VICE, Thorpe, North & Western, Sandy, UT; Karen Blakemore, Phelps Dunbar - B.R., Baton Rouge, LA.

**Prior History:** Broussard v. Go-Devil Mfg. Co. of La., Inc., 2008 U.S. Dist. LEXIS 51833 (M.D. La., June 9, 2008)

**Counsel:** [\*\*1] For Kyle Broussard, Gator Tail, L.L.C. (3:08-cv-00124-BAJ-RLB), Plaintiffs: Joel W. Mohrman, LEAD ATTORNEY, PRO HAC VICE, Anderson L. Cao, PRO HAC VICE, McGlinchey Stafford- Houston, Houston, TX; Juston M. O'Brien, McGlinchey Stafford PLLC, Baton Rouge, LA.

For Mud Buddy L.L.C. (3:08-cv-00125-BAJ-RLB), Counter Claimant: Samuel C. Straight, LEAD ATTORNEY, PRO HAC VICE, R. Layne Royer, Ltd., Baton Rouge, LA; Allen D. Darden, Phelps Dunbar, LLP, Baton Rouge, LA; Jed H. Hansen, PRO HAC VICE, Thorpe, North & Western, Sandy, UT; Karen Blakemore, Phelps Dunbar - B.R., Baton Rouge, LA.

For Go-Devil Manufacturing Co. of LA., Inc., doing business as Go-Devil Manufacturers of Louisiana, Inc. (3:08-cv-00124-BAJ-RLB), Defendant: Fredrick R. Tulley, LEAD ATTORNEY, John P. Murrill, Robin P. Troups, Taylor, Porter, Brooks & Phillips, Baton Rouge, LA.

**Judges:** BRIAN A. JACKSON, CHIEF UNITED STATES DISTRICT JUDGE.

**Opinion by:** BRIAN A. JACKSON

For Go-Devil Manufacturing Co. of LA., Inc. (3:08-cv-00124-BAJ-RLB), Counter Claimant, Fredrick R. Tulley, LEAD ATTORNEY, John P. Murrill, Robin P. Troups, Taylor, Porter, Brooks & Phillips, Baton Rouge, LA.

**Opinion**

[\*757] **RULING AND ORDER**

For Kyle Broussard, Gator Tail, L.L.C. (3:08-cv-00124-BAJ-RLB), Counter Defendants: Anderson L. Cao, LEAD ATTORNEY, PRO HAC VICE, McGlinchey Stafford- Houston, Houston, TX.

**I. INTRODUCTION**

In this consolidated patent infringement action,<sup>1</sup> Plaintiff Gator Tail, LLC alleges that certain boat motors produced by Defendants Go-Devil Manufacturing Co. of La., Inc. and Mud Buddy, LLC infringe the asserted claims of the patents-in-suit. (08-cv-00124 Doc. 20;

For Gator Tail, L.L.C., Kyle Broussard, (3:08-cv-00125-BAJ-RLB), Plaintiffs, Counter

<sup>1</sup> The Court consolidated civil actions 3:08-cv-00124-BAJ-RLB *Kyle Broussard, et al. v. Go-Devil Manufacturing Co. of La., Inc. d/b/a Go-Devil Manufacturers of Louisiana, Inc.* and 3:08-cv-00125-BAJ-RLB *Gator Tail, et al. v. Mud Buddy, LLC d/b/a Mud Buddy Manufacturing* for the *Markman* hearing and for bench trial on the issue of patent validity, pursuant to Rule 42(a)(1). (See 08-cv-00124 Doc. 82, 90).

08-cv-00125 Doc. 1)). On January 27 through January 31, 2014 the court held a three-day bench trial limited to the issue of patent validity. (See 08-cv-00124 Doc. 95 at p. 2; [\*\*3] see *also* Docs. 121, 123). Presently before the Court are the parties' post-trial proposed findings of fact and conclusions of law concerning the validity of the patents-in-suit. (08-cv-00124 Doc. 124, 125, 130, 131; 08-cv-00125 Docs. 139, 140, 144, 145)).

Pursuant to Federal Rule of Civil Procedure ("Rule") 52(a), and after having considered the entire record in this case and the applicable law, the Court concludes: (1) all asserted claims of the patents-in-suit are invalid due to obviousness; (2) United States Patent Number 7,052,340 is invalid due to lack of written description; and (3) Claims 1, 8, and 14 of United States Patent Number 7,052,340, and Claim 1 of United States Patent Number 7,297,035 [\*\*758] are each invalid due to lack of definiteness. These findings of fact and conclusions of law [\*\*4] are set forth in further detail below.

## II. FINDINGS OF FACT<sup>2</sup>

### A. The parties

1. Plaintiff and Counter Defendant Kyle Broussard ("Mr. Broussard") is a Louisiana resident residing at 2402 Terre Ruelle, New Iberia, Louisiana 70563. (08-cv-00125 Doc. 1 at ¶ 4).

2. Plaintiff and Counter Defendant Gator Tail, LLC ("Gator Tail") is a Louisiana limited liability company with its principal place of business at 306 Broussard Road, Loreauville, Louisiana 70552. (08-cv-00124 Doc. 96-1 at ¶ 1).

3. Mr. Broussard founded Gator Tail while completing his degree in mechanical engineering at the University of Louisiana. (*Id.* at ¶ 15).

4. Gator Tail designs, builds, and sells outboard boat motors usable in shallow water, and is the owner of certain patents related to such motors. (*Id.* at ¶¶ 2, 7, 14).

5. Where appropriate, Mr. Broussard and Gator Tail will be collectively referred to as "Plaintiffs."

6. Defendant and Counter Claimant Go-Devil Manufacturing Co. of Louisiana, LLC ("Go-Devil") is

[\*\*5] the successor to Go-Devil Manufacturing Co. of Louisiana, Inc., and is a Louisiana limited liability company with its principal place of business at 18649 Womack Road, Baton Rouge, Louisiana 70817. (*Id.* at ¶¶ 9-10).

7. Go-Devil manufactures and sells outboard boat motors usable in shallow waters, as well as blinds, custom boats, and boating accessories. (*Id.* at ¶ 13).

8. At all times material hereto, Go-Devil has done, and continues to do business in the Middle District of Louisiana. (*Id.* at ¶ 14).

9. Defendant and Counter Claimant Mud Buddy, LLC d/b/a Mud Buddy Manufacturing ("Mud Buddy") is a Utah corporation with its principal place of business at 7956 South, 1530 West, West Jordan, Utah 84088. (*Id.* at ¶ 8).

10. Mud Buddy manufactures and sells outboard boat motors usable in shallow waters, as well as blinds, custom boats, and boating accessories. (*Id.* at ¶ 11).

11. At all times material hereto, Mud Buddy has done, and continues to do business in the Middle District of Louisiana. (*Id.* at ¶ 12).

12. Where appropriate, Go-Devil and Mud Buddy will be collectively referred to as "Defendants."

13. The Court has subject matter jurisdiction, as well as personal jurisdiction over all parties.

### B. [\*\*6] Background

14. Plaintiff Gator Tail and Defendants Go-Devil and Mud Buddy are each manufacturers of "mud motors," (see Trial Transcript, Vol. I, Jan. 27, 2014 (hereinafter "Transcript Vol. I") at p. 99)—*i.e.*, "outboard air-cooled motors, apparatuses, and assemblies for use on boats in shallow water and muddy environments," (Doc. 82 at p 3; see *also* Doc. 96-1 at ¶¶ 11, 13, 15). Such motors are used primarily for hunting and fishing.<sup>3</sup>

15. Prior to the early 2000s, the mud motor market was dominated by "long-tail" mud motors, (see Trial Transcript, [\*\*759] Vol. III, Jan. 31, 2014 (hereinafter

<sup>2</sup> Prior to trial, the parties submitted an exhibit of undisputed facts in conjunction with their Pretrial Order. (08-cv-00124 Doc. 96-1). Where appropriate, the Court takes its findings of fact from these undisputed facts.

<sup>3</sup> At trial, Defendant Mud Buddy's expert witness, Don Kueny, described the concept behind a mud motor in the following terms:

"Transcript Vol. III") at p. 130), so-named because the drive shaft connecting the motor's engine to its propeller was upwards of six feet long, causing the propeller to extend a considerable distance behind the transom of the boat on which the motor is mounted. (See Transcript Vol. I at pp. 121-22).

16. Long-tail mud motors continue to be manufactured and sold. (Transcript Vol. III at p. 145).

17. However, in the last decade, consumers have increasingly switched to "surface-drive" (or "short-tail") mud motors, which achieve certain advantages over the traditional long-tail motor, such as greater horsepower, speed, and maneuverability. (See Transcript Vol. III at pp. 144-46).

18. Plaintiffs are the owners of certain patents related to surface-drive/short-tail mud motors. (See Gator Tail Ex. 1; Gator Tail Ex. 2).

### C. The patents-in-suit<sup>4</sup>

#### 1. United States Patent Number 7,052,340

19. United States Patent Number 7,052,340 ("the '340 Patent"), entitled "Method and Apparatus for Air Cooled Outboard [sic] Motor for Small Marine Craft," naming Kyle Broussard as inventor, was issued on May 30, 2006, based on an application filed on September 15, 2003. (Gator Tail Ex. 1 at 0652).

20. The '340 Patent arises out of a provisional application filed September 17, 2002. (*Id.*).

#### 2. United States Patent Number 7,297,035

21. United States Patent Number 7,297,035 ("the '035 Patent"), entitled "Marine Craft Adapted for Shallow Water Operation," naming Kyle Broussard [\*\*9] as inventor, was issued on November 20, 2007, based on an application filed on May 22, 2006. (Gator Tail Ex. 2 at p. 01838).

22. The '035 Patent is a continuation-in-part of the '340 Patent. (*Id.*).

23. Plaintiff Gator Tail is the assignee of the '340 and '035 Patents. (Doc. 96-1 at ¶ 2).<sup>5</sup>

24. The '340 and '035 Patents each describe substantially the same invention, specifically:

[\*760] A relatively high horsepower air-cooled engine in one embodiment of this invention is adapted to an efficient belt drive assembly capable of being transom mounted to small flat bottom boats in much the same manner as conventional outboard engines. The drive is equipped with a lower drive shaft that does not extend below the bottom of the boat but extends a sufficient distance behind [\*\*10] the boat to insure contact with the water for conventional propulsion. A unique pivotal

---

The concept of [a mud motor is to put] the propellor well behind the boat where the water wells up in kind of a mound. So you can keep the propellor very close to the surface and not run into things deep in the water. It allows you to use in shallow water. It's that part of the idea that the water mounds up behind the boat. And if you can put the propellor back behind the boat, it can run much—much higher in the water and still have solid water. And it avoids having the propellor deep, so you can run in shallow water. Particularly in the Far East it was developed more for debris in the water as much as for shallow water. But the whole [\*\*7] idea is to put the propellor in that moun[d] of water so it can run shallow.

(Transcript II at pp. 92-93 (Mr. Kueny)).

<sup>4</sup> Initially, Plaintiffs sued Defendants for infringement of *three* Patents. (See 08-cv-00124 [\*\*8] Doc. 20 at ¶¶ 10-12; 08-cv-00125 Doc. 1 at ¶ 11). However, Plaintiffs have since abandoned their cause of action as to U.S. Patent Number 7,048,600 ("the '600 Patent"), entitled "Method and Apparatus for Air Cooled Outboard Motor for Small Marine Craft," and naming Kyle Broussard as inventor, (08-cv-00124 Doc. 20-1 at p. 1). (See 08-cv-00124 Doc. 54 at p. 1 ("The defendant willfully infringes on certain claims in Gator Tail's U.S. Patents Nos. 7,052,340 and 7,297,035." (footnotes omitted)); 08-cv-00125 Doc. 45 at p. 1 (same)). Accordingly, the Court does not address the '600 Patent.

<sup>5</sup> Although the '035 Patent lists Gator Tail as the assignee, the '340 Patent does not indicate an assignee. (*Compare* Gator Tail Ex. 2 at p. 01838 (the '035 Patent, listing Gator Tail as the assignee), *with* Gator Tail Ex. 1 at p. 0652 (the '340 Patent, failing to list an assignee)). However, based on the parties' stipulation, the Court accepts as true that Gator Tail is, indeed, the assignee of the '340 Patent. (See Doc. 96-1 at ¶ 2).

arrangement allows the engine and drive assembly to be positioned for proper angle of attack when the propeller is in contact with mud and vegetation below the bottom of the boat. This arrangement allows for a much shorter turning radius than can be achieved by the related prior art transom mounted mud motor systems. The engine mount includes incremental tilt positioning capability and a pivotal horizontal steering handle. The propeller is capable of providing propulsion when in contact with solids such as mud and vegetation, and provides relatively fast hull speed in deep water. A clutch is provided to disengage the engine from the drive and an electric drive motor is provided in contact with the belt drive for turning the drive in a reverse direction.

(Gator Tail Ex. 2 at p. 01852 ('035 Patent, "Summary of Invention"); see also Gator Tail Ex. 1 at p. 0657 ('340 Patent, "Summary of Invention")).

25. Selected renderings of the '340 Patent. (Gator Tail Ex. 1 at p. 0654)

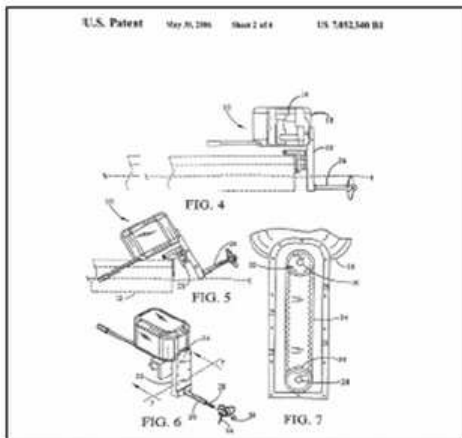

26. Rendering of the '035 Patent. (Gator Tail Ex. 2 at p. 01840).

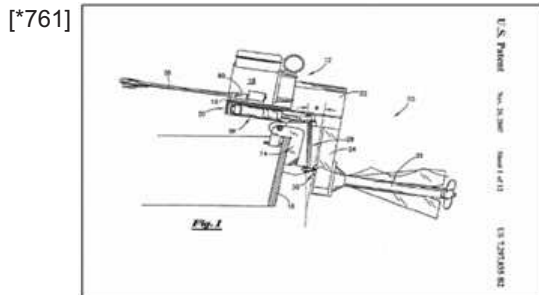

#### D. The asserted claims

27. Plaintiffs assert that Defendants' products [\*11] "infringe[] claims 1, 3-9, and 11-13 of the '340

patent." (08-cv-00124 Doc. 54 at p. 1 n.1; 08-cv-00125 Doc. 45 at p.1 n.1 (same)).

28. Further, Plaintiffs assert that Defendants' products "infringe[] claims 1, 3-7, and 9-13 of the '035 patent." (08-cv-00124 Doc. 54 at p. 1 n.2; 08-cv-00125 Doc. 45 at p.1 n.2 (same)).

#### 1. The asserted claims of the '340 Patent

i. Claim 1

29. Claim 1 of the '340 Patent reads:

A portable drive assembly having means for temporary attachment to the transom of a shallow draft watercraft said portable drive assembly comprising an elongated drive housing enclosing an upper drive assembly a lower driven assembly and a timing belt connecting said upper drive assembly to said lower driven assembly, an engine mounting plate attached externally to said drive housing located adjacent said upper drive assembly perpendicular to said drive housing said lower driven assembly further comprising a propeller shaft partially enclosed within a shaft housing attached to said drive housing adjacent said driven assembly extending at least 12 inches beyond said drive housing and a propeller attached to said propeller shaft.

(Gator Tail Ex. 1 at p. 0658).

ii. Claim 3

30. Claim 3 of the [\*12] '340 Patent reads: "The portable drive assembly according to claim 1 wherein said drive system further comprises steering and throttle controls." (*Id.*).

iii. Claim 4

31. Claim 4 of the '340 Patent reads:

The portable drive assembly according to claim 1 wherein said propeller shaft assembly further comprises a shaft housing having a vertical triangular fin located below said shaft housing, a shaft supported adjacent each end by thrust bearings in a manner whereby said shaft extends beyond each of said thrust bearings and a plurality of internal seals [\*762] located along said shaft outboard of said thrust bearings.

(*Id.*).

iv. Claim 5

32. Claim 5 of the '340 Patent reads: "The portable drive assembly according to claim 1 wherein said upper drive assembly and said lower driven assembly further include timing pulleys compatible with said timing belt said belt being rotationally unobstructed or acted upon by other bodies." (*Id.*).

v. Claim 6

33. Claim 6 of the '340 Patent reads: "The portable drive assembly according to claim 1 further comprising a self contained air cooled utility engine having a horizontal output shaft attached to said engine mounting plate said output shaft coupled to said upper drive [\*\*13] assembly." (*Id.*).

vi. Claim 7

34. Claim 7 of the '340 Patent reads: "The portable drive assembly according to claim 6 wherein said drive housing is water sealed." (*Id.*).

vii. Claim 8

35. Claim 8 of the '340 Patent reads:

A portable outboard engine and drive assembly having means for temporary attachment to the transom of a shallow draft watercraft comprising:

- a) a sealed housing containing a timing belt drive assembly comprising an upper drive pulley assembly and a lower driven pulley assembly;
- b) an engine mounting plate attached externally to said sealed housing located adjacent said upper drive pulley assembly perpendicular to said sealed housing;
- c) a propeller shaft partially enclosed within a shaft housing attached to said sealed housing extending from said driven pulley assembly at least 12 inches beyond said sealed housing;
- d) a propeller attached to said propeller shaft;
- e) a pivotal means for temporarily attaching said sealed drive housing to a boat transom; and
- f) an air cooled engine mounted to said engine-mounting plate and coupled externally to said upper drive pulley assembly.

(*Id.*).

viii. Claim 9

36. Claim 9 of the '340 Patent reads: "The portable drive assembly according to claim [\*\*14] 8 wherein said pivotal means comprises both horizontal and vertical pivoting means." (*Id.*).

ix. Claim 11

37. Claim 11 of the '340 Patent reads: "The portable drive assembly according to claim 8 wherein said propeller shaft assembly further comprises a plurality of thrust bearings and seals at each end of said shaft housing." (*Id.*).

x. Claim 12

38. Claim 12 of the '340 Patent reads: "The portable drive assembly according to claim 11 wherein said propeller shaft assembly further comprises a rudder fin extending below said shaft housing." (*Id.*).

xi. Claim 13

39. Claim 13 of the '340 Patent reads: "The portable drive assembly according to claim 8 wherein said propeller shaft assembly is in excess of 18 inches in length." (*Id.* at p. 0659).

[\*763] **2. The asserted claims of the '035 Patent i. Claim 1**

40. Claim 1 of the '035 Patent reads:

A marine craft comprising a hull comprising a transom; and a portable drive assembly temporarily attached to the transom, the portable drive assembly comprising an elongated drive housing enclosing an upper drive assembly and a lower driven assembly and a timing belt connecting the upper drive assembly to the lower driven assembly; and an engine mounting plate attached externally [\*\*15] to the drive housing adjacent the upper drive assembly perpendicular to the drive housing; wherein the lower driven assembly comprises a propeller shaft at least a portion of which is enclosed within a shaft housing attached to the drive housing adjacent the driven assembly, the shaft housing extending in excess of 18 inches beyond the drive housing, and a propeller attached to the propeller shaft.

# Explore Litigation Insights

Docket Alarm provides insights to develop a more informed litigation strategy and the peace of mind of knowing you're on top of things.

## Real-Time Litigation Alerts



Keep your litigation team up-to-date with **real-time alerts** and advanced team management tools built for the enterprise, all while greatly reducing PACER spend.

Our comprehensive service means we can handle Federal, State, and Administrative courts across the country.

## Advanced Docket Research



With over 230 million records, Docket Alarm's cloud-native docket research platform finds what other services can't. Coverage includes Federal, State, plus PTAB, TTAB, ITC and NLRB decisions, all in one place.

Identify arguments that have been successful in the past with full text, pinpoint searching. Link to case law cited within any court document via Fastcase.

## Analytics At Your Fingertips



Learn what happened the last time a particular judge, opposing counsel or company faced cases similar to yours.

Advanced out-of-the-box PTAB and TTAB analytics are always at your fingertips.

## API

Docket Alarm offers a powerful API (application programming interface) to developers that want to integrate case filings into their apps.

## LAW FIRMS

Build custom dashboards for your attorneys and clients with live data direct from the court.

Automate many repetitive legal tasks like conflict checks, document management, and marketing.

## FINANCIAL INSTITUTIONS

Litigation and bankruptcy checks for companies and debtors.

## E-DISCOVERY AND LEGAL VENDORS

Sync your system to PACER to automate legal marketing.