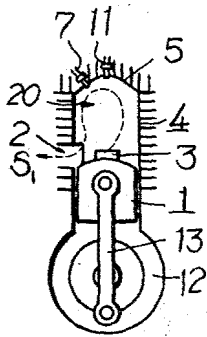
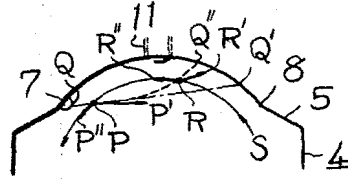

**FIG. 1**



**FIG. 4**



**FIG. 5**

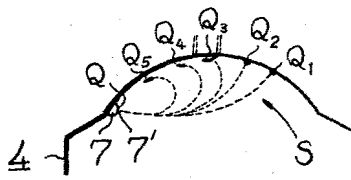

**FIG. 6**

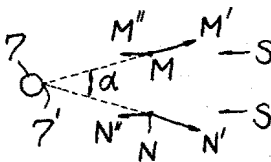

**FIG. 7**

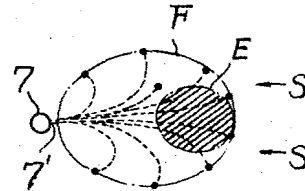

**FIG. 2**

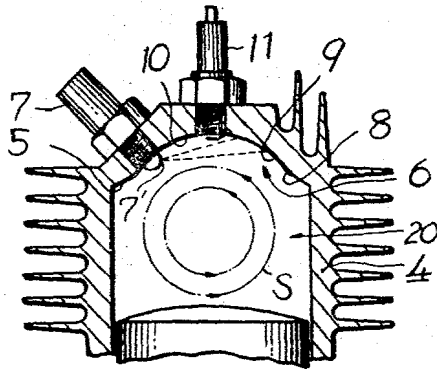

**FIG. 8**

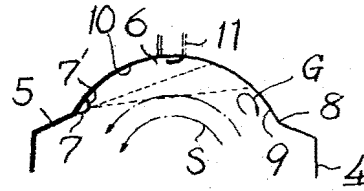

**FIG. 3**

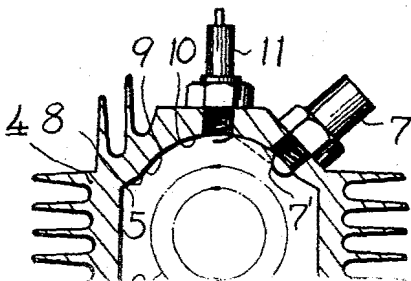

**FIG. 9**

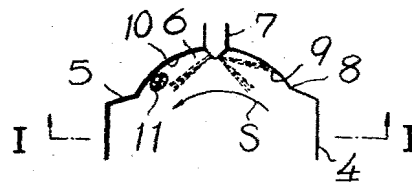

**FIG. 10**

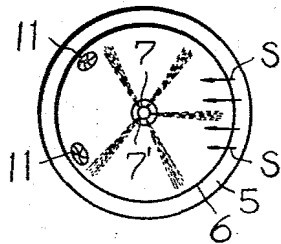

**FIG. 11**

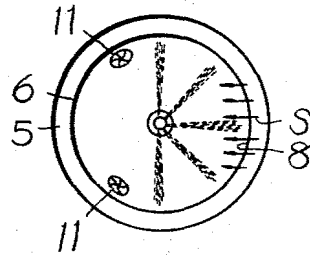

**FIG. 12**

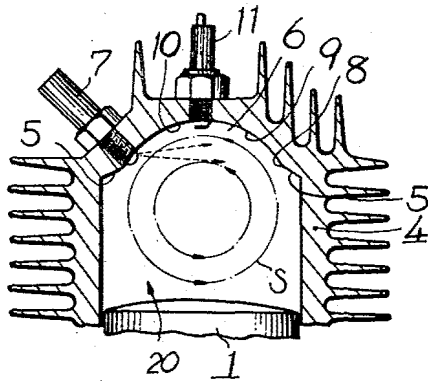

**FIG. 13**

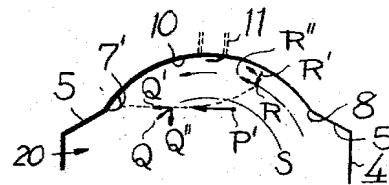

**FIG. 15**

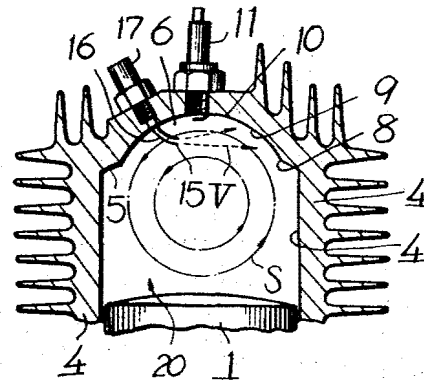

**FIG. 14**

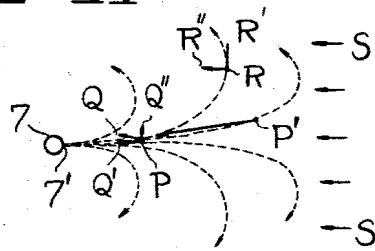

**FIG. 16**

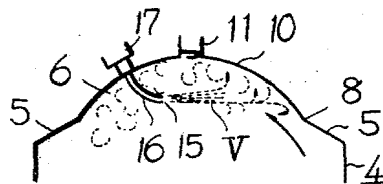

**FIG. 17**

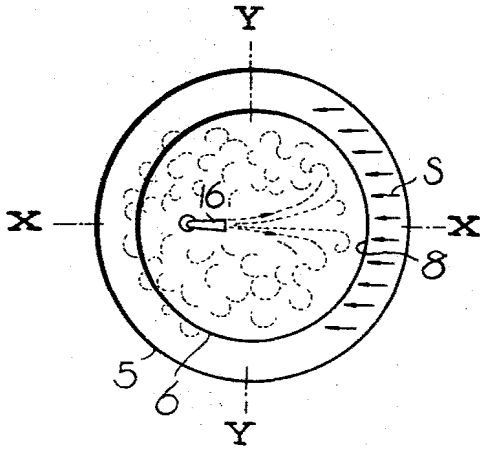

**FIG. 18**

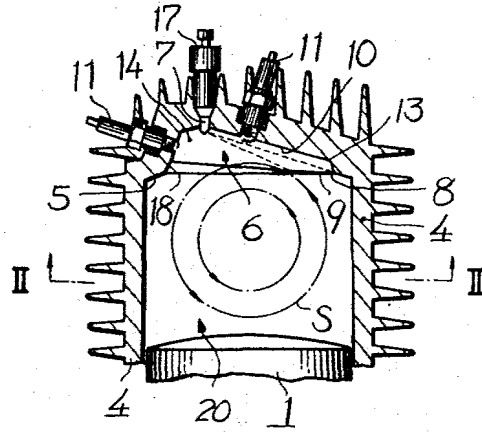

**FIG. 20**

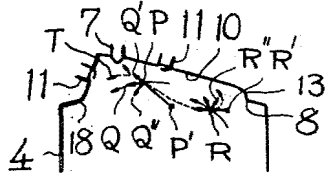

**FIG. 19**

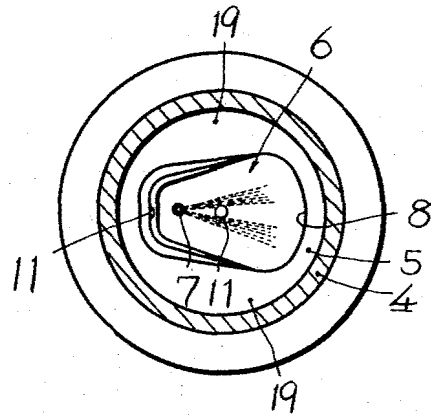

**FIG. 21**

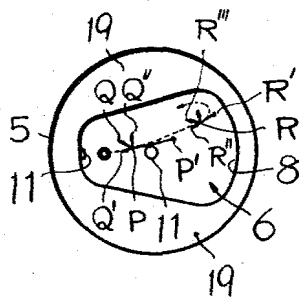

**FIG. 22**

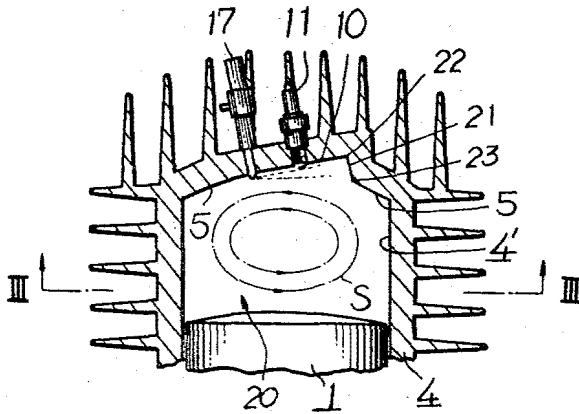

**FIG. 24**

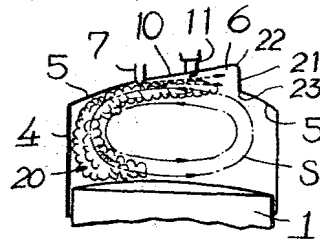

**FIG. 23**

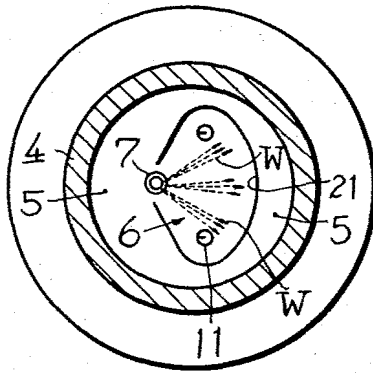

**FIG. 25**

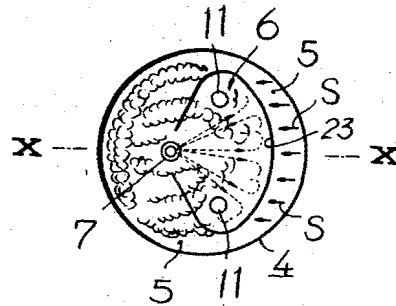

1

2

3,572,298

**STRATIFIED CHARGE ENGINE**

Shigeru Onishi, 31-13 Higashiyama 3-chome, Kanazawa-shi, Ishikawa-ken, Japan, and Saburo Yui, 12-7 Himonya 3-chome, Meguru-ku, Tokyo, Japan

Filed Jan. 6, 1969, Ser. No. 789,227

Claims priority, application Japan, Jan. 8, 1968, 43/599; Jan. 11, 1968, 43/1,083; Feb. 16, 1968, 43/9,413; June 10, 1968, 43/39,424; July 27, 1968, 43/52,757

Int. Cl. F02b 72/00

U.S. Cl. 123-32

8 Claims

**ABSTRACT OF THE DISCLOSURE**

An internal combustion engine of the stratified charge type wherein the purification of the exhaust fan from the combustion chambers is provided with elimination of noxious components in the emissions thus attaining improved ignitability and combustibility particularly for betterment of performance and durability in full load operation.

**DETAILED EXPLANATION OF THE INVENTION**

This invention relates to a reciprocating, piston-type internal combustion engine of stratified charge system which achieves charge stratification for complete burning of fuel in the cylinder that serves as combustion chamber, and more specifically to an internal combustion engine of Otto-cycle type for spark ignition of air-fuel mixture, wherein stratified charge combustion is accomplished, that is, stratified charge of a readily ignitable, combustible mixture is burned in the neighborhood of the region including spark plug.

Efforts for improvements of internal combustion engines, especially gasoline engines, have heretofore been directed to higher power output and thermal efficiency and better mechanism. As for the prevention of air pollution due to the exhaust emissions, the manufacturers have simply relied upon some attachments for reductions of noxious gases. However, those emissions containing carbon monoxide, CO, hydrocarbons, HC, and nitrogen oxides, NOx, have so rapidly increased in recent years that the control and removal of such noxious substances posing public hazard, or production of cleaner exhaust gases, has come to the fore as a problem of paramount importance that must be solved even at some sacrifice of the power output, thermal efficiency and other features of the engines.

As is well known, it is important in the combustion chambers of internal combustion engines that injected fuel, either mist or vapor in form, be thoroughly mixed with a necessary amount of air for perfect burning. The perfect combustion within the engines incorporating an improved system of charge stratification in the combustion chambers would give cleaner emissions. If the engines are moreover equipped with means for purifying the exhaust with any improvement rather than sacrifice of the engine performance, the result would then be more than satisfactory.

It is known that, in conventional gasoline engines, the concentrations of such noxious gases can be invariably reduced to by far lower levels by effecting good combustion of mixtures at sufficiently lean air-fuel ratios for the control of the harmful emissions.

Generally, a decrease of fuel supply with respect to a given air intake improves the fuel consumption although the engine develops less power. With leaner air-fuel ratios, however, the fuel consumption is increased and thermal efficiency is affected adversely because of slower burning

deviated mixtures with each cylinder. Thus, fuels burned at excessively lean air-fuel ratios produce only poor thermal efficiency and output, and the clean mixtures slow down the flame propagation, as physical phenomena of inevitable nature. The use of a lean air-fuel ratio thus causes a drop of burning rate, which in turn results in the rise of exhaust temperature, and hence damage to the exhaust valve, irregular combustion cycle, engine roughness, insufficient output, poor acceleration and difficulty of starting. It is for these reasons that the use of lean air-fuel ratios has not been contemplated in the past.

More recently, as part of attempts for making use of lean air-fuel ratios, a number of proposals have been made along the stratified charge concept whereby a spark plug is provided in a part of main combustion chamber or in an auxiliary chamber, and a gaseous mixture of combustible range is formed, ignited and burned, and then the combustion of a leaner mixture in the rest or whole of the main cylinder is effected. It is known that, according to this stratified charge system whereby the engine is operated on a relatively rich fuel mixture maintained in the region around the spark plug and on a lean overall mixture provided in the entire space inside the cylinder (i.e., with excess air), it is made possible to improve the specific heat of active gas for a closer approach to an air cycle, prevent heat dissociation, and reduce the cooling heat loss to the surroundings, so that improved thermal efficiency and reduced fuel consumption can be realized and, further, because the combustion is effected with ample supply of air, the noxious components of exhaust emissions can be fairly reduced.

However, while many versions of the stratified charge concept have been studied and developed up to now, none of them has attained a satisfactory degree of perfection for the control of noxious contents of exhaust emissions as well as in the usefulness in actual applications because of imperfection in design and controllability, complicity and other problems in construction, etc. Especially, it is practically much more difficult to maintain an air-fuel ratio greater than 15:1 which corresponds (approximately) to the theoretical mixing ratio, or between about 16:1 and 17:1 which is generally believed feasible, in every cylinder of the engine, throughout the entire load range. Moreover, the higher the air-fuel ratio the slower the combustion rate and the higher the exhaust temperature. This tends to invite troubles in the exhaust valve system, increased unsmoothness of combustion process, engine roughness, and frequent occurrence of misfire, which in turn results in difficulty of starting and drop of acceleration. What is worse, the air-fuel ratio in this range can increase the emission of NOx to a maximum. If the compression ratio is increased for better performance, the NOx emission will further increase. In order to reduce the latter possibility, attempts have hitherto been made only at some sacrifice of engine performance. Retardation of ignition timing is an example. However, this results in a drop of power output and a rise of exhaust temperature.

Recirculating a part of exhaust gas to the intake side proves effective but it again reduces the available power, and use of a very rich mixture to make up for the power loss leads to increased CO emission. As a whole, therefore, this approach is not contributory to the purification of exhaust emissions.

Charge stratification is beneficial for the improvement of thermal efficiency at part-load operation, but for an engine to run under full load it fails to ensure good gassification and mixing of fuel with air so that the engine can yield sufficiently high power. In order that the system can meet the requirement of engines operating at full

# Explore Litigation Insights

Docket Alarm provides insights to develop a more informed litigation strategy and the peace of mind of knowing you're on top of things.

## Real-Time Litigation Alerts



Keep your litigation team up-to-date with **real-time alerts** and advanced team management tools built for the enterprise, all while greatly reducing PACER spend.

Our comprehensive service means we can handle Federal, State, and Administrative courts across the country.

## Advanced Docket Research



With over 230 million records, Docket Alarm's cloud-native docket research platform finds what other services can't. Coverage includes Federal, State, plus PTAB, TTAB, ITC and NLRB decisions, all in one place.

Identify arguments that have been successful in the past with full text, pinpoint searching. Link to case law cited within any court document via Fastcase.

## Analytics At Your Fingertips



Learn what happened the last time a particular judge, opposing counsel or company faced cases similar to yours.

Advanced out-of-the-box PTAB and TTAB analytics are always at your fingertips.

## API

Docket Alarm offers a powerful API (application programming interface) to developers that want to integrate case filings into their apps.

## LAW FIRMS

Build custom dashboards for your attorneys and clients with live data direct from the court.

Automate many repetitive legal tasks like conflict checks, document management, and marketing.

## FINANCIAL INSTITUTIONS

Litigation and bankruptcy checks for companies and debtors.

## E-DISCOVERY AND LEGAL VENDORS

Sync your system to PACER to automate legal marketing.