

## Federal Circuit Has Held Obvious To Combine Features From Two Microchips Into One Microchip

### *MCM Portfolio LLC*



Federal circuit affirms Board's conclusion "that one of ordinary skill in the art would have had both the knowledge and the inclination to place the functionality taught by Kobayashi and Kikuchi on a single chip."

*MCM Portfolio LLC v. Hewlett-Packard Company*, 812 F.3d 1284, 1294 (Fed. Cir. 2015)

## IV. Purported Deficiencies Raised By Patent Owner

- ~~✘ *Beard In View Of Rathmann Does Not Disclose The Claimed "Energy Consuming Load" ('726, '749, '952, '980)*~~
- ~~✘ *Beard And Rathmann In View Of Danielson Does Not Disclose Microchip Control Of Both The "Energy Consuming Load" And The Indicator ('970)*~~

**(3) *Beard In View Of Rathmann Does Not Disclose Deactivation Of A "Function" In Addition To The Visible Indicator (All Patents)***

(4) *Beard In View Of Rathmann Does Not Disclose A Different Activation Signal For The Function ('726, '952, '970)*

(5) *Beard In View Of Rathmann Does Not Disclose A Power Source Enclosed In The Product Housing ('726, '952, '980)*

(6) *Beard And Rathmann In View Of Danielson Does Not Disclose A Touch Sensor And On/Off Switch In The Same User Interface ('726, '980)*

(7) *Beard In View Of Rathmann Does Not Disclose The Claimed "Location Indicator" ('970)*

(8) *Beard In View Of Rathmann Does Not Disclose Activation Of A Visible Indication Without Activating Load ('980)*

## Claims Require Activating and Deactivating a Function

### '726 Patent

1. A method for controlling a product comprising a power source, or a connection for a power source, and an energy consuming load, said method including the step of providing an electronic module comprising an electronic circuit including a microchip and a touch sensor forming part of a user interface, said microchip adapted to control the activation of a visible indication in response to an activation signal received from the user interface while operation of the load is unaffected.

IPR2015-01171 Ex.1001 ('726 Patent) Claim 1

2. The method of claim 5 wherein the method also includes the step of automatically deactivating a function that was activated in response to an activation signal, received from said user interface, a predetermined period of time after it was activated.

IPR2015-01171 Ex.1001 ('726 Patent) Claim 6

2. The method of claim 1 wherein the method also includes the step of automatically deactivating a function that was activated in response to an activation signal, received from said user interface, a predetermined period of time after it was activated.

IPR2015-01171 Ex.1001 ('726 Patent) Claim 9

- 1** Whether *Beard* '290's Display of Remaining Battery Capacity is a Visible Indication
- 2** Whether *Beard* '290's Disclosure of Remaining Time Estimates for Remaining Battery Life is a Function

## PO Contends Remaining Battery Capacity And Time Estimates Are A Single Function

### PO's Response

and Ex. 1003 at ¶¶ 157 and 158. However, the display of remaining battery capacity and the display of the time estimate amount to a single function of providing "charge status" in Beard, singularly activated in response to the same activation signal. Ex. 1005 at 10:37-59. Certainly, one of ordinary skill in the art

IPR2015-01171 Paper 14 (PO Resp.) at 43

## ***Beard* '290 Repeatedly Describes Calculating And Displaying Battery Capacity As A Different Function From Calculating And Displaying A Remaining Time Estimate**

### *Beard* '290 Patent

battery life. Instead of (or in addition) displaying <sup>1</sup>the percentage of available battery capacity, the control circuitry <sup>2</sup>223 interacts with the display 225 to deliver the time estimates to the operator. With peak, typical and low power

IPR2015-01171 Ex. 1005 (*Beard*) at 11:45-48 (see also Abstract, 10:37-40, 12:59-65)

## PO's Expert Concedes That Each Of These Are Different "Functions"

### Morley, Patent Owner's Expert

Q. <sup>2</sup> Determining remaining time in a battery  
<sup>1</sup> is a different function than just  
determining battery capacity, right?

A. Correct. The -- determining the time, you would need to know what the draw is, and if you know the capacity and the draw, you can estimate the time until it's discharged.

IPR2015-01171 Ex. 1035 (Morley Tr.) at 126:16-22

## IV. Purported Deficiencies Raised By Patent Owner

- ~~**X** *Beard In View Of Rathmann Does Not Disclose  
The Claimed "Energy Consuming Load" ('726, '749, '952, '980)*~~
- ~~**X** *Beard And Rathmann In View Of Danielson Does Not Disclose  
Microchip Control Of Both The "Energy Consuming Load" And The Indicator ('970)*~~
- ~~**X** *Beard In View Of Rathmann Does Not Disclose  
Deactivation Of A "Function" In Addition To The Visible Indicator (All Patents)*~~
- (4) *Beard In View Of Rathmann Does Not Disclose  
A Different Activation Signal For The Function ('726, '952, '970)***
- (5) *Beard In View Of Rathmann Does Not Disclose  
A Power Source Enclosed In The Product Housing ('726, '952, '980)***
- (6) *Beard And Rathmann In View Of Danielson Does Not Disclose  
A Touch Sensor And On/Off Switch In The Same User Interface ('726, '980)***
- (7) *Beard In View Of Rathmann Does Not Disclose  
The Claimed "Location Indicator" ('970)***
- (8) *Beard In View Of Rathmann Does Not Disclose  
Activation Of A Visible Indication Without Activating Load ('980)***



## Claims Require “An Activation Signal”

### '726 Patent

**1.** A method for controlling a product comprising a power source, or a connection for a power source, and an energy consuming load, said method including the step of providing an electronic module comprising an electronic circuit including a microchip and a touch sensor forming part of a user interface, said microchip adapted to control the activation of a visible indication in response to **an activation signal** received from the user interface while operation of the load is unaffected.

IPR2015-01171 Ex.1001 ('726 Patent) Claim 1

### '726 Patent

**6.** The method of claim 5 wherein the method also includes the step of automatically deactivating a function that was activated in response to **an activation signal**, received from said user interface, a predetermined period of time after it was activated.

IPR2015-01171 Ex.1001 ('726 Patent) Claim 6

**19.** The method of claim 1 wherein the method also includes the step of automatically deactivating a function that was activated in response to **an activation signal**, received from said user interface, a predetermined period of time after it was activated.

IPR2015-01171 Ex.1001 ('726 Patent) Claim 19

**PO argues repeated references to “an activation signal”  
must refer to different signals**

## PO Argues Repeated References To “An Activation Signal” Must Refer To Different Signals

### PO's Response

Additionally, the claimed function is "activated in response to an activation signal." As the claims recite "***an* activation signal [emphasis added]**," it is clear that this activation signal does not derive antecedent support from any prior claim recitation and thereby does not refer back to the same activation signal for activating the visible indication. Accordingly, **the claimed "function" is necessarily activated in response to a different activation signal from that for activating the visible indication.** This separate and independent activation of the

IPR2015-01171 Paper 14 (PO Resp.) at 22

# “An Activation Signal” Means One Or More Activation Signals

## '726 Patent

**1.** A method for controlling a product comprising a power source, or a connection for a power source, and an energy consuming load, said method including the step of providing an electronic module comprising an electronic circuit including a microchip and a touch sensor forming part of a user interface, said microchip adapted to control the activation of a visible indication in response to **an activation signal** received from the user interface while operation of the load is unaffected.

IPR2015-01171 Ex.1001 ('726 Patent) Claim 1

**6.** The method of claim 5 wherein the method also includes the step of automatically deactivating a function that was activated in response to **an activation signal**, received from said user interface, a predetermined period of time after it was activated.

IPR2015-01171 Ex.1001 ('726 Patent) Claim 6

**19.** The method of claim 1 wherein the method also includes the step of automatically deactivating a function that was activated in response to **an activation signal**, received from said user interface, a predetermined period of time after it was activated.

IPR2015-01171 Ex.1001 ('726 Patent) Claim 19

- Indefinite article “an” means only each signal may be the same or different
- Nothing in the claims or specification requires these activation signals to be different

## **“An Activation Signal” ('970 Patent)**

## The Claims Of The '970 Patent Simply Define The Signal In A More Specific Way In Each Claim

### '970 Patent

- b) wherein the visible indicator is activated at least to indicate **an activation signal** from the switch when the load is not activated; and
- c) wherein the visible indicator is also used to indicate a power level of the power source when the load is switched off and the product is not connected to a mains supply.

IPR2015-01173 Ex. 1001, ('970 patent) Claim 1 (excerpt)

**12. An electronic module of claim 10 wherein a function, selected by **a user interface activation signal** is automatically shut off after a predetermined period of time.**

IPR2015-01173 Ex. 1001, ('970 patent) Claim 12

**19. An electronic module of claim 1 wherein the configuration selected is (b), and the microchip also controls upon receiving **a switch activation signal from a touch sensor**, at least the activation of a function that automatically shuts off a period after such activation.**

IPR2015-01173 Ex. 1001, ('970 patent) Claim 19

- All three are “activation signals”
- Dependent claims narrow to specific types of activation signals
- Indefinite article means each signal could be the same or different

## IV. Purported Deficiencies Raised By Patent Owner

- ~~✘ *Beard In View Of Rathmann Does Not Disclose  
The Claimed "Energy Consuming Load" ('726, '749, '952, '980)*~~
- ~~✘ *Beard And Rathmann In View Of Danielson Does Not Disclose  
Microchip Control Of Both The "Energy Consuming Load" And The Indicator ('970)*~~
- ~~✘ *Beard In View Of Rathmann Does Not Disclose  
Deactivation Of A "Function" In Addition To The Visible Indicator (All Patents)*~~
- ~~✘ *Beard In View Of Rathmann Does Not Disclose  
A Different Activation Signal For The Function ('726, '952, '970)*~~
- (5) *Beard In View Of Rathmann Does Not Disclose  
A Power Source Enclosed In The Product Housing ('726, '952, '980)***
- (6) *Beard And Rathmann In View Of Danielson Does Not Disclose  
A Touch Sensor And On/Off Switch In The Same User Interface ('726, '980)*
- (7) *Beard In View Of Rathmann Does Not Disclose  
The Claimed "Location Indicator" ('970)*
- (8) *Beard In View Of Rathmann Does Not Disclose  
Activation Of A Visible Indication Without Activating Load ('980)*

## ***Beard* '290 Discloses That The Power Source Is Enclosed In The Product Housing**

### **'726 Patent**

**3. The method of claim 1 wherein the power source is not mains and wherein the power source is enclosed in the product housing.**

IPR2015-01171 Ex.1001 ('726 Patent) Claim 3

### **PO's Response**

correspond to the claimed load, the batteries 231 and the components of the device 203 are not included in the same housing. Ex. 2002 at ¶ 58.

Paper 14 (PO Resp.) at 40

# Beard '290 Discloses That The Power Source Is Enclosed In The Product Housing

## Beard '290 Patent

ing. In particular, a battery pack 103 may be inserted in or removed from a slot in the bottom of a portable terminal 101.

IPR2015-01171 Ex. 1005 (*Beard*) at 9:15-16

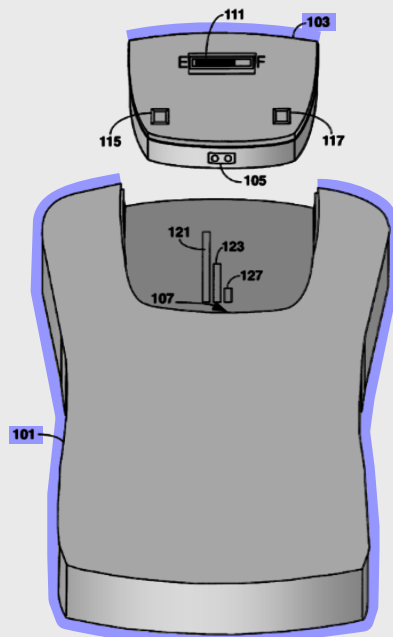

FIG. 8

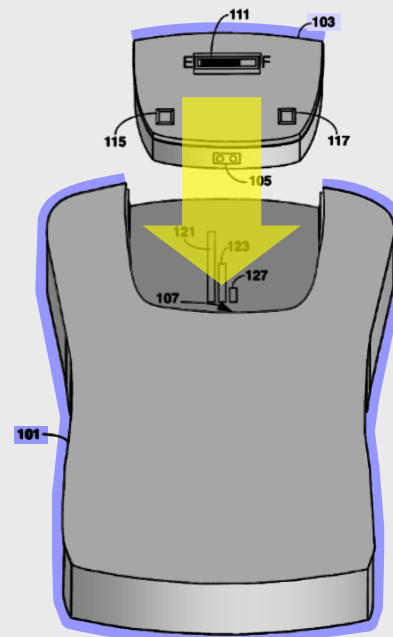

FIG. 8



# Beard '290 Discloses That The Power Source Is Enclosed In The Product Housing

## Beard '290 Patent

ing. In particular, a battery pack 103 may be inserted in or removed from a slot in the bottom of a portable terminal 101.

IPR2015-01171 Ex. 1005 (*Beard*) at 9:15-16

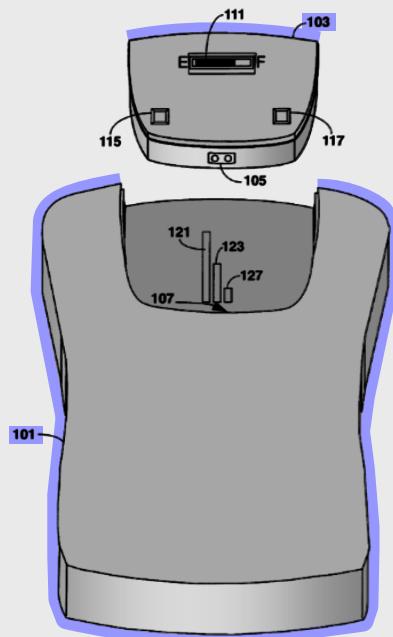

FIG. 8

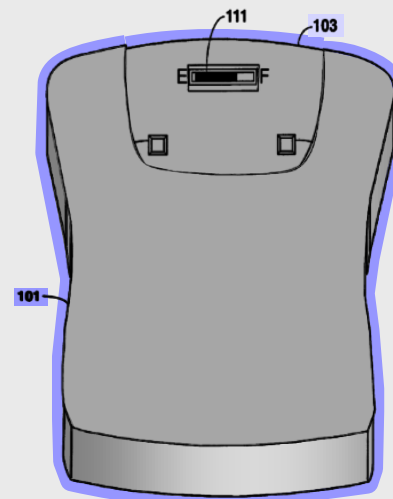

FIG. 8 (annotated)

product housing

## IV. Purported Deficiencies Raised By Patent Owner

- ~~✘ *Beard In View Of Rathmann Does Not Disclose  
The Claimed "Energy Consuming Load" ('726, '749, '952, '980)*~~
- ~~✘ *Beard And Rathmann In View Of Danielson Does Not Disclose  
Microchip Control Of Both The "Energy Consuming Load" And The Indicator ('970)*~~
- ~~✘ *Beard In View Of Rathmann Does Not Disclose  
Deactivation Of A "Function" In Addition To The Visible Indicator (All Patents)*~~
- ~~✘ *Beard In View Of Rathmann Does Not Disclose  
A Different Activation Signal For The Function ('726, '952, '970)*~~
- ~~✘ *Beard In View Of Rathmann Does Not Disclose  
A Power Source Enclosed In The Product Housing ('726, '952, '980)*~~
- (6) *Beard And Rathmann In View Of Danielson Does Not Disclose  
A Touch Sensor And On/Off Switch In The Same User Interface ('726, '980)***
- (7) *Beard In View Of Rathmann Does Not Disclose  
The Claimed "Location Indicator" ('970)*
- (8) *Beard In View Of Rathmann Does Not Disclose  
Activation Of A Visible Indication Without Activating Load ('980)*

## PO Seeks To Create Another New Limitation, The Single User Interface, Where None Exists

### '726 Patent

4. The method of claim 1 wherein the method also includes the step of **activating or deactivating the product via commands received from the user interface.**

IPR2015-01171 Ex.1001 ('726 Patent) Claim 4

### PO's Response

1007 at FIG. 20; *See also* Ex. 2002 at ¶ 66. **This is plainly different from the claimed user interface, which is a single user interface that *includes a microchip* and that receives commands for activating or deactivating the product as well as an activation signal for activation of a visible indicating.**

IPR2015-01171 Paper 14 (PO Resp.) at 47

## The “User Interface” Is Not Limited To A Single Component—It Can Have Multiple Parts, One Of Which Must Be A Touch Sensor According To The Claims

### '726 Patent

1. A method for controlling a product comprising a power source, or a connection for a power source, and an energy consuming load, said method including the step of providing an electronic module comprising an electronic circuit including a microchip and a touch sensor forming part of a user interface, said microchip adapted to control the activation of a visible indication in response to an activation signal received from the user interface while operation of the load is unaffected.

IPR2015-01171 Ex.1001 ('726 Patent) Claim 1

4. The method of claim 1 wherein the method also includes the step of activating or deactivating the product via commands received from the user interface.

IPR2015-01171 Ex.1001 ('726 Patent) Claim 4

**Beard '290 Discloses A Touch Sensor Used To Activate Visible Indications And Danielson Discloses An "On/Off Switch" Used To Activate Or Deactivate The Product**

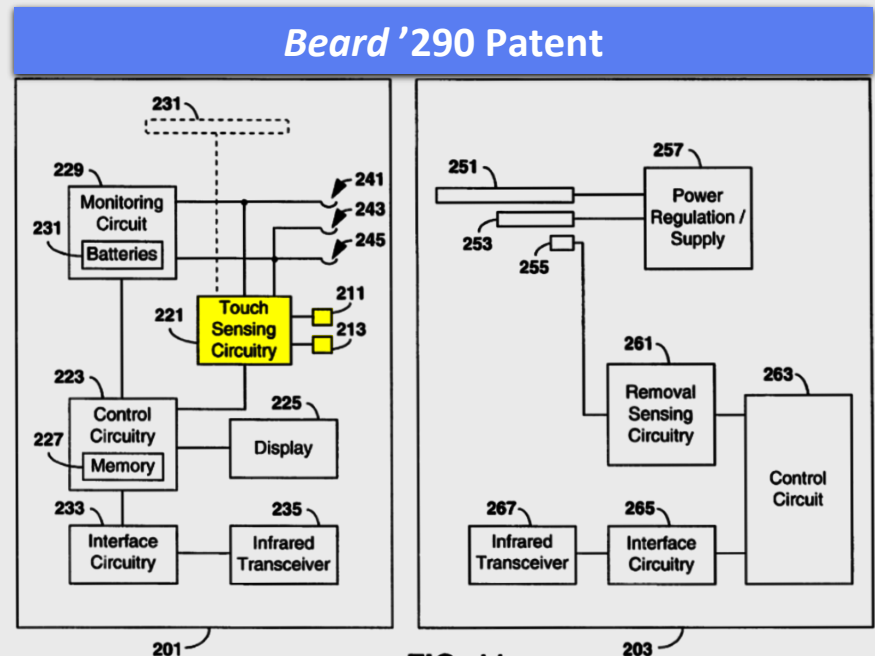

FIG. 11

IPR2015-01171 Ex. 1005 (Beard) at Fig. 11

**Danielson '728 Patent**

option. The switch 332 may now be operated manually in conjunction with an **ON/OFF switch** of the data terminal 10

IPR2015-01171 Ex. 1007 (Danielson) at 22:65-66

## PO's Expert Confirmed That A User Interface Is Simply "An Interface On A Device That Allows A User To Interact With The Device"

### Morley, Patent Owner's Expert

A. To me, a user interface is what it says in the plain use of the language. **It's an interface on a device that allows a user to interact with the device.** So it's something that a user interacts with on a product, user interface.

IPR2015-01171 Ex. 1036 (Morley Microsoft Tr.) at 151:24-152:3

Q. So you wouldn't consider a desktop computer that had both a keyboard and a mouse to have a single user interface? You'd consider those multiple interfaces?

A. Those might be combined into one, and the mouse might even be plugged into the keyboard in that case.

Q. How about the on/off switch above a keyboard on a laptop? Would that be part of the user interface?

A. Yes.

IPR2015-01171 Ex. 1035 (Morley Tr.) at 136:16-137:4

**'980 Patent**

## The "ON/OFF" Switch In *Danielson* Meets This Limitation

### '980 Patent

4. An electronic module according to claim 1, wherein the user interface enables **selection of activation and deactivation functions of the product.**

IPR2015-01174 Ex.1001 ('980 Patent) Claim 4

### *Danielson* '728 Patent

option. The switch **332** may now be operated manually in conjunction with an **ON/OFF switch** of the data terminal **10**

IPR2015-01174 Ex. 1007 (*Danielson*) at 22:65-66



## **Beard '290's Disclosure Of Activating And Deactivating Display Of Battery Capacity And Remaining Time Estimates Also Meets This Limitation**

### **'980 Patent**

**4. An electronic module according to claim 1, wherein the user interface enables selection of activation and deactivation functions of the product.**

IPR2015-01174 Ex.1001 ('980 Patent) Claim 4

### **Beard '290 Patent**

**FIG. 9 is a perspective view illustrating a further embodiment of the battery pack of FIG. 8 which includes an LCD (Liquid Crystal Display) screen that is used to display both available capacity and remaining time estimates.**

IPR2015-01174 Ex. 1005 (*Beard*) at 10:37-40

## IV. Purported Deficiencies Raised By Patent Owner

- ~~✗ *Beard In View Of Rathmann Does Not Disclose The Claimed "Energy Consuming Load" ('726, '749, '952, '980)*~~
- ~~✗ *Beard And Rathmann In View Of Danielson Does Not Disclose Microchip Control Of Both The "Energy Consuming Load" And The Indicator ('970)*~~
- ~~✗ *Beard In View Of Rathmann Does Not Disclose Deactivation Of A "Function" In Addition To The Visible Indicator (All Patents)*~~
- ~~✗ *Beard In View Of Rathmann Does Not Disclose A Different Activation Signal For The Function ('726, '952, '970)*~~
- ~~✗ *Beard In View Of Rathmann Does Not Disclose A Power Source Enclosed In The Product Housing ('726, '952, '980)*~~
- ~~✗ *Beard And Rathmann In View Of Danielson Does Not Disclose A Touch Sensor And On/Off Switch In The Same User Interface ('726, '980)*~~

**(7) *Beard In View Of Rathmann Does Not Disclose The Claimed "Location Indicator" ('970)***

**(8) *Beard In View Of Rathmann Does Not Disclose Activation Of A Visible Indication Without Activating Load ('980)***

## Claims Require A "Location Indicator"

### '970 Patent, Claim 1

**1. An electronic module for use with a product comprising an energy consuming load and a power source or a connection to a power source, said module comprising a microchip, and a switch;**

**said switch being a user interface and does not form a serial link in a circuit that transfers power from the power source to power the load, and said microchip controlling a luminous visible **location indicator** that is not the load according to at least one configuration selected from the following group:**

- a) wherein the visible indicator at least indicates a condition of the product upon receiving a signal from the user interface switch, and wherein the switch is a touch sensor type switch;**
- b) wherein the visible indicator is activated at least to indicate an activation signal from the switch when the load is not activated; and**
- c) wherein the visible indicator is also used to indicate a power level of the power source when the load is switched off and the product is not connected to a mains supply.**

IPR2015-01173 Ex. 1001 ('970 Patent), Claim 1

## *Beard* '290 Discloses A "Location Indicator"

### '970 Patent, Claim 1 (excerpt)

said switch being a user interface and does not form a serial link in a circuit that transfers power from the power source to power the load, and said microchip controlling a luminous visible **location indicator** that is not the load according to at least one configuration selected from the following group:

IPR2015-01173 Ex. 1001 ('970 Patent), Claim 1 (excerpt)

### *Beard* '290 Patent

The rechargeable battery pack **10** has disposed on one side of the housing **16** a battery capacity indicator display **14** which provides a means for displaying and indicating to the operator the remaining capacity of the rechargeable battery pack **10**. In an exemplary embodiment of the present invention, the battery indicator display is a linear array of **four light-emitting diodes which sequentially illuminate** in accordance with the capacity of the rechargeable battery pack **10**.

IPR2015-01173 Ex. 1005 (*Beard*), 4:59-67

**PO Would Interpret “Location Indicator”  
To Preclude Activation by User Interface**

## PO Would Interpret “Location Indicator” To Preclude Activation by User Interface

### PO's Response

2003 at ¶66. In other words, for the charge indicators to activate and be illuminated, the location of the battery pack or the location of the contacts of Beard are necessarily known such that the location has no reason to be indicated because a user must touch the contacts to operate the indicator.

IPR2015-01173 Paper 19 (PO Resp.) at 13

### Morley, Patent Owner's Expert

of the contacts 211 or the battery pack 201. The nature of indicating a location is an indication, at least in part, of a thing unknown and not in contact with the operator.

IPR2015-01173 Ex. 2003 (Morley Decl.) at ¶69

## '970 Patent Claims Expressly Contradict PO's Narrow Interpretation Of A Location Indicator

### '970 Patent, Claim 1

1. An electronic module for use with a product comprising an energy consuming load and a power source or a connection to a power source, said module comprising a microchip, and a switch;

said switch being a user interface and does not form a serial link in a circuit that transfers power from the power source to power the load, and said microchip controlling a luminous visible **location indicator** that is not the load according to at least one configuration selected from the following group:

- a) wherein the visible indicator at least indicates a condition of the product **upon receiving a signal from the user interface switch, and wherein the switch is a touch sensor type switch;**
- b) wherein the visible indicator is activated at least to indicate an activation signal from the switch when the load is not activated; and
- c) wherein the visible indicator is also used to indicate a power level of the power source when the load is switched off and the product is not connected to a mains supply.

IPR2015-01173 Ex. 1001 ('970 Patent), Claim 1

Claims state that the "location indicator" can be activated by user interface

# '970 Patent Specification Discloses Indicator Being Activated By Touch Sensor

## '970 Patent

According to another embodiment of the present invention, an output may be provided to indicate a condition, e.g. a battery is in good or bad condition. It may also be suitable to assist in locating a device, e.g. but not limited to a flashlight, in the dark. This may be a separate output pin or may be, according to another embodiment, shared with the MMI switch input. (See FIG. 11) This output or indicator may be a LED. Referring to FIG. 11, indicator/output device 1104 may, for example, be an LED. When microchip 1113 pulls the line 1114 to high, the LED 1104 shines. LED 1104 may also shine when switch 1111 is closed by the user.

IPR2015-01173 Ex. 1001, ('970 patent), 9:49-58

Specification describes "location indicator" can be activated by user interface

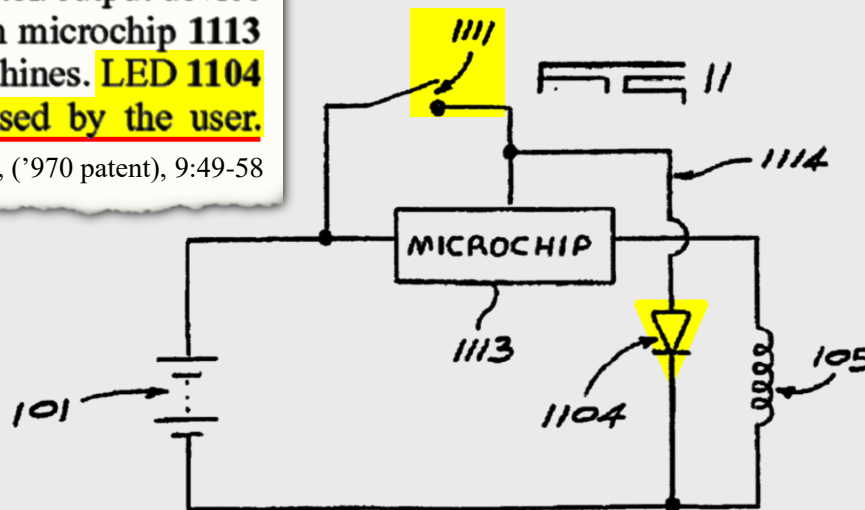

IPR2015-01173 Ex. 1001, ('970 patent), Fig 11



## '970 Patent Specification Discloses Indicator Being Activated By Touch Sensor

### '970 Patent

According to another embodiment of the present invention, an output may be provided to indicate a condition, e.g. a battery is in good or bad condition. It may also be suitable to assist in locating a device, e.g. but not limited to a flashlight, in the dark. This may be a separate output pin or may be, according to another embodiment, shared with the MMI switch input. (See FIG. 11) **This output or indicator may be a LED.** Referring to FIG. 11, indicator/output device **1104** may, for example, be an LED. When microchip **1113** pulls the line **1114** to high, the LED **1104** shines. LED **1104** may also shine when switch **1111** is closed by the user.

IPR2015-01173 Ex. 1001 ('970 patent), 9:49-58

### Beard '290 Patent

**pack 10.** In an exemplary embodiment of the present invention, the battery indicator display is **a linear array of four light-emitting diodes which sequentially illuminate** in accordance with the capacity of the rechargeable battery **pack 10.**

IPR2015-01173 Ex. 1005 (*Beard*), 4:63-67

## PO's Expert Admits *Beard* '290's LEDs Are A Location Indicator

### Morley, Patent Owner's Expert

Q. Let me give you a hypothetical. Let's suppose you and I were in this room and it was totally dark and we couldn't see each other. And in your hand was a battery pack as described in the *Beard* prior art reference. And in the dark, you touched the contacts and illuminated the LEDs. Are you with me so far?

A. Yes.

Q. And let's say they stayed on for a period of ten seconds. If I looked at you in the dark and my view was unobstructed, wouldn't it tell me the location of the battery pack that was in your hand?

A. It would.

Q. And I didn't need to touch it for that to happen, did I?

A. No, you didn't.

Q. Or to know where the device was beforehand, right?

A. Correct.

IPR2015-01173 Ex. 1036 (Morley Tr.) at 160:15-161:12

## IV. Purported Deficiencies Raised By Patent Owner

- ~~✗ *Beard In View Of Rathmann Does Not Disclose The Claimed "Energy Consuming Load" ('726, '749, '952, '980)*~~
- ~~✗ *Beard And Rathmann In View Of Danielson Does Not Disclose Microchip Control Of Both The "Energy Consuming Load" And The Indicator ('970)*~~
- ~~✗ *Beard In View Of Rathmann Does Not Disclose Deactivation Of A "Function" In Addition To The Visible Indicator (All Patents)*~~
- ~~✗ *Beard In View Of Rathmann Does Not Disclose A Different Activation Signal For The Function ('726, '952, '970)*~~
- ~~✗ *Beard In View Of Rathmann Does Not Disclose A Power Source Enclosed In The Product Housing ('726, '952, '980)*~~
- ~~✗ *Beard And Rathmann In View Of Danielson Does Not Disclose A Touch Sensor And On/Off Switch In The Same User Interface ('726, '980)*~~
- ~~✗ *Beard In View Of Rathmann Does Not Disclose The Claimed "Location Indicator" ('970)*~~

**(8) *Beard In View Of Rathmann Does Not Disclose Activation Of A Visible Indication Without Activating Load ('980)***

## Prior Art Discloses Activation Of A Visual Indication Without Activating Load

The issue is whether *Beard* '290 describes controlling a “visible indicator . . . when the load is not activated by the user”

### '980 Patent

1. An electronic module for use with a product, said product comprising a power source or a connection for a power source, and an energy consuming load, said module also comprising,

a circuit comprising a microchip and a touch sensor forming part of a user interface, wherein the microchip also

- ① controls a visible indicator that is activated in response to an activation signal received from the user interface
- ② when the load is not activated by the user.

IPR2015-01174 Ex. 1001 ('980 Patent), Claim 1

## Prior Art Discloses Activation Of A Visual Indication On Battery Pack Even When Battery Pack Not Connected To Load

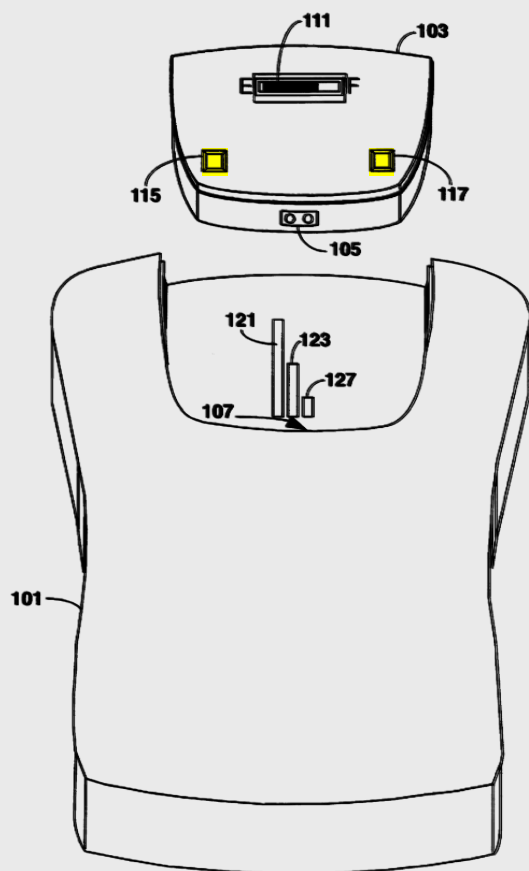

**FIG. 8**

IPR2015-01174 Ex. 1005 (*Beard*), Fig. 8

### *Beard '290 Patent*

- ① The battery pack 103 comprises an LCD display 111 that, upon request, provides an indication of current battery capacity. To request the indication, a user merely places one finger on a contact 115 and one finger on a contact 117 to complete a pathway monitored by a sensing circuit within the battery pack 103. In response, the display 111 is activated to display the current battery capacity. As illustrated, the battery capacity is represented in a fuel-gauge type display with “E” and “F” designating “empty” and “full”, respectively.
- ② Such requests to display battery capacity can be conducted when the battery pack 103 is either installed within or removed from the portable terminal 101. However, to

IPR2015-01174 Ex. 1005 (*Beard*) at 9:16-33

**Because the visible indication can be displayed when the battery pack is removed, the indication can also be displayed when inserted but the load is not activated**

## ***Beard* '290 Expressly States That The Device Is Not Always On— It Is Only Operational “When The Operator So Desires”**

### **Patent Owner's Response**

activated. *Id.* at 10:27-30 and 12:19-24. In other words, **Beard discloses a terminal device that is operational and draws power whenever the batter pack is connected thereto, irrespective and independent of the activating of the visible indicator (display) in the battery pack.** Ex. 2002 at ¶ 57. Nowhere in *Beard* is any

IPR2015-01174 Paper 14 (PO Resp.) at 38

### ***Beard* '290 Patent**

pack contact 245. When fully inserted, the battery pack contacts 241, 243 and 245 engage the corresponding contacts 251, 253 and 255, and, **if sufficient power is available, the device 203 may enter a fully operational state when the operator so desires.** Upon beginning to remove the battery

IPR2015-01174 Ex. 1005 (*Beard*) at 12:2-4

## PO Argues That Visible Indication Only Activated When Load Is Active In *Beard* '290 Because Every Component Of The *Beard* '290 Device Is Always On

### Patent Owner's Response

indicator (display) in the battery pack. Ex. 2002 at ¶ 57. Nowhere in *Beard* is any suggestion that a particular energy consuming component of the terminal device is not activated during this operational state. For at least this reason, *Beard* fails to

IPR2015-01174 Paper 14 (PO Resp.) at 38

### '980 Patent

1. An electronic module for use with a product, said product comprising a power source or a connection for a power source, and an energy consuming load, said module also comprising,

a circuit comprising a microchip and a touch sensor forming part of a user interface, wherein the microchip also

- ① controls a visible indicator that is activated in response to an activation signal received from the user interface
- ② when the load is not activated by the user.

IPR2015-01174 Ex. 1001 ('980 Patent), Claim 1

Nothing in the claim requires terminal device in an operational state

## IV. Purported Deficiencies Raised By Patent Owner

- ~~✘ Beard In View Of Rathmann Does Not Disclose The Claimed "Energy Consuming Load" ('726, '749, '952, '980)~~
- ~~✘ Beard And Rathmann In View Of Danielson Does Not Disclose Microchip Control Of Both The "Energy Consuming Load" And The Indicator ('970)~~
- ~~✘ Beard In View Of Rathmann Does Not Disclose Deactivation Of A "Function" In Addition To The Visible Indicator (All Patents)~~
- ~~✘ Beard In View Of Rathmann Does Not Disclose A Different Activation Signal For The Function ('726, '952, '970)~~
- ~~✘ Beard In View Of Rathmann Does Not Disclose A Power Source Enclosed In The Product Housing ('726, '952, '980)~~
- ~~✘ Beard And Rathmann In View Of Danielson Does Not Disclose A Touch Sensor And On/Off Switch In The Same User Interface ('726, '980)~~
- ~~✘ Beard In View Of Rathmann Does Not Disclose The Claimed "Location Indicator" ('970)~~
- ~~✘ Beard In View Of Rathmann Does Not Disclose Activation Of A Visible Indication Without Activating Load ('980)~~



**The Board Should Decline To Construe “User Interface”  
('726, '952, '980)**

# The Board Should Decline To Construe “User Interface”

Term	Patent Owner’s Proposed Construction
“user interface”	“an interface between a device and its operator <u>to receive and manage an input command from the operator</u> ”

**PO never applies this construction in its analysis and never explains why this construction could be relevant to any issue in this proceeding**

**Only terms which are in controversy need to be construed and only to the extent necessary to resolve the controversy**

*Vivid Techs., Inc. v. Am. Sci. & Eng’g, Inc.*, 200 F.3d 795, 803 (Fed. Cir. 1999)

**The Board Should Decline To Construe  
“Touch Sens[or/ing] Functions” (’952)**

## The Board Should Decline To Construe “Touch Sens[or/ing] Functions”

Term	Patent Owner's Proposed Construction
“touch sens[or/ing] functions”	“functions of the device that are activated or controlled in response to touch sensor inputs”

**PO never applies this construction in its analysis and never explains why this construction could be relevant to any issue in this proceeding**

**Only terms which are in controversy need to be construed and only to the extent necessary to resolve the controversy**

*Vivid Techs., Inc. v. Am. Sci. & Eng'g, Inc.*, 200 F.3d 795, 803 (Fed. Cir. 1999)

# Construction of “Function”

# PO's Proposed Construction Should Be Rejected

Term	Petitioner's Proposed Construction	Patent Owner's Proposed Construction
<p><b>“A function that was activated in response to an activation signal, received from said user interface”</b></p> <p><i>(Claims 6 and 19)</i></p>	<p>plain meaning</p>	<p><i>“a function, different from activation of a visible indication, that was activated in response to an activation signal, different from an activation signal for activating the visible indication, received from the same user interface as the activation signal for activating the visible indication”</i></p>

See, e.g., IPR2015-01171 Rep. at 15-16; IPR2015-01172 Rep. at 15-16; IPR2015-01173 Rep. at 12-13; IPR2015-01174 Rep. at 15-16; IPR2015-01175 Rep. at 17; IPR2015-01603 Rep. at 15-16

## The Specification Uses "Function" Very Broadly

### '726 Patent

direction of microchip 103. Microchip 103 embedded in the battery can have any number of intelligent functions pre-programmed therein, such as, for example but not limited to, battery strength monitoring, recharging, adjustment of average current through a current switch, intermittent power delivery sequences, and so on. Examples of suitable micro-

IPR2015-01171 Ex. 1001 ('726 Patent) at 8:58-63

controlled switches wherein said switches can be programmed to perform a variety of functions including, for example, turning the flashlight off after a pre-determined time interval, blinking, or dimming, etc. According to a still further

IPR2015-01171 Ex. 1001 ('726 Patent) at 1:55-58

# PO Reads In Negative Limitations Without Justification

Term	Patent Owner's Proposed Construction
<p><b>“A Function</b></p> <p><b>That Was Activated In Response To An Activation Signal,</b></p> <p><b>Received From Said User Interface”</b></p> <p><i>(Claims 6 and 19)</i></p>	<p>“a function,</p> <div style="background-color: #ffe6e6; padding: 5px; margin: 5px 0;"><i>different from activation of a visible indication,</i></div> <p>that was activated in response to an activation signal,</p> <div style="background-color: #ffe6e6; padding: 5px; margin: 5px 0;"><i>different from an activation signal for activating the visible indication,</i></div> <p>received from the same user interface</p> <div style="background-color: #ffe6e6; padding: 5px; margin: 5px 0;"><i>as the activation signal for activating the visible indication”</i></div>

See, e.g., IPR2015-01171 Rep. at 15-16; IPR2015-01172 Rep. at 15-16; IPR2015-01173 Rep. at 12-13; IPR2015-01174 Rep. at 15-16; IPR2015-01175 Rep. at 17; IPR2015-01603 Rep. at 15-16



## Patent Owner Argues "Function" Must Have A Different Meaning From Activation Of The Visible Indication

### PO's Response

convey different meanings). Thus, the "function" of claims 6 and 19 is different from activation of a visible indication.

IPR2015-01171 Paper 19 (PO Resp.) at 22

### Petitioners Agree "Function" Is Broader Than "Activation Of A Visible Indication"

**Function**

**activation of the  
visible indication**

**Car**

**sedan**

## PO's Own Expert Acknowledges Activation Of The Indicator Is A Function

### Patent Owner's Expert

Q. So indicating a condition of the battery, whether it's good or bad, is another example of a function according to the Global Touch patents, right?

A. Yes.

IPR2015-01171 Ex. 1035 (Morley Tr.) at 118:21-119:3

## PO's Own Expert Acknowledges Activation Of The Indicator Is A Function

### Patent Owner's Expert

50. Put another way, Claim 21 recites two separate function activations in response to an activation signal received via the user interface switch. One is recited as the activation of the visible indicator. Then, an

IPR2015-01172 Ex. 2002 (Morley Decl.) at ¶50

## When PO Intended To Claim Only "Other Functions," It Did So Expressly

### '749 Patent

21. A method of implementing a user interface for a product comprising connections for a power supply and at least one energy consuming load, using at least a touch sensor user interface switch and a visible indicator, wherein the method includes the steps of:

- (a) activating the indicator in response to a user interface switch activation signal;
- (b) activating the indicator when the load is not activated by the user;
- (c) performing an automatic delayed deactivation of a function that was activated in response to an activation signal received via the user interface switch.

IPR2015-01172 Ex. 1001 ('749 Patent), Claim 21

### U.S. Patent Application No. 09/169,395

1. An intelligent flashlight having an exhaustible power source, said flashlight comprising:

at least one non-energy transferring MMI signal switch and a microchip in communication with said switch,

the switch being capable of only transmitting a signal to said microchip that the switch has been activated or deactivated by a user, and

the microchip being in communication with the power source and controlling the on/off functions and at least one other function of the device in response to the receipt of activation and deactivation signals from the switch.

IPR2015-01172 Ex. 1038 (395 Application), Claim 1

***Beard '290's Timing Circuit***

## *Beard* '290 Discloses A Timing Circuit To Time How Long The Display Is Active

### *Beard* '290 Patent

an LCD display 157 for viewing. The contact 155 is recessed to prevent unintentional such initiation. Moreover, a timing circuit prevents the contact 155 from holding the display 157 and associated circuitry in an active state for more than a ten (10) second interval. After the ten second display period, deactivation occurs whether or not the contact 155 is being touched. Thereafter, the contact 155 must be released and

IPR2015-01171 Ex. 1005 (*Beard*) at 10:51-56

## Use Of This Timing Circuit Is A Function

### Patent Owner's Expert

Q. At line 50, the specification of the *Beard* patent describes that, quote, A timing circuit prevents the contact 155 from holding the display 157 and associated circuitry in an active state for more than a ten-second interval. After the ten-second display period, deactivation occurs whether or not the contact 155 is being touched, close quote. Did I read that correctly?

A. Yes.

Q. Using a timing function as we discussed in reference to the Global Touch patents is another example of a function according to those Global Touch patents, right?

A. That was cited as a function there, yes.

IPR2015-01171 Ex. 1035 (Morley Tr.) at 125:4-18

## Beard '290's Timing Circuit Meets the Other Claim Limitations

### '726 Patent

6. The method of claim 5 wherein the method also includes the step of automatically deactivating a function that was activated in response to an activation signal, received from said user interface, a predetermined period of time after it was activated.

IPR2015-01171 Ex.1001 ('726 Patent) Claim 6

### Beard, Petitioners' Expert

9. This "timing circuit" is activated when the user presses the "touch contact 155." (Beard at 10:48-50.) The touch contact sends an activation signal, via the control circuitry, which activates the display and the timing circuit.

10. This timing circuit is automatically deactivated after ten seconds. The timing circuit "prevents the contact 155 from holding the display 157 and associated circuitry in an active state from more than a ten (10) second interval." At the conclusion of this ten second interval, both the display and the timing circuit are automatically deactivated. The timing circuit is deactivated, among other reasons, to preserve battery power.

IPR2015-01171 Ex. 1034 (Beard Suppl. Decl.) at ¶¶9-10



***Rathmann* Discloses Activating A Visual Indication  
Without Activating Load**

## PO Argues *Rathmann* Does Not Disclose Visible Indicator Activated “When The Load Is Not Activated By The User”

### PO's Response

As set forth above, claim 1 requires a visible indication activated by the microchip in response to an activation signal received from a user interface *when the load is not activated by the user*. In other words, the claimed visible indicator

\* \* \*

Beard necessarily fails to disclose or suggest a visible indicator that is activated when a load of the product is not activated.

Nor does Rathmann cure this deficiency. Petitioners allege that Rathmann,

IPR2015-01174 Paper 14 (PO Resp.) at 37-41

## **Rathmann Displays The Visible Indication When The Load Is Not Activated By The User**

### *Rathmann '869 Patent*

The smart battery module **28** includes a hybrid IC **32** containing a microprocessor **50** (FIG. 3) and a plurality of sensor means for generating analog signals representative of battery voltage, current and temperature. The module also includes a series of four (4) LEDs **34** driven by an LED drive circuit **53** and a manually actuatable switch **35** which may be manually actuated by an end user to determine the state of charge in the battery even when the battery has been removed from the host device **16**. The LEDs **34** may be used

IPR2015-01174 Ex. 1006 (*Rathmann*) at 16:24-29

**Because the visible indication can be displayed when the battery module is removed, the indication can also be displayed when inserted but the load is not activated**