

WM-DD III

SERVICE MANUAL

Refer to MDR-15L Service Manual issued previously for information of headphones supplied with this set.

AEP Model

HEADPHONES jacks (stereo minijacks)

REW ►► (rewind) button
 ◀◀ FF (fast forward) button
 ◀ PLAY button
 ■ STOP button

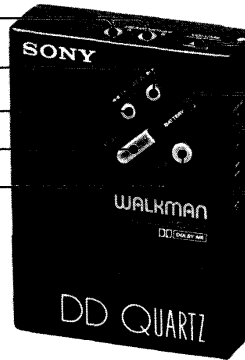

VOLUME control
 BATTERY indicator
 DOLBY NR switch
 TAPE selector

Dolby noise reduction manufactured under license from Dolby Laboratories Licensing Corporation. "DOLBY" and the double-D symbol **DD** are trademarks of Dolby Laboratories Licensing Corporation.

PHOTO: BLACK TYPE

SPECIFICATIONS

Tape track
4-track 2-channel stereo

Fast winding time
Approx. 2 min. with Sony Cassette C-60

Frequency response
40-15,000 Hz

Wow and flutter
±0.13% (DIN)
0.08% WRMS (NAB)

Power output
Headphones:
20 mW + 20 mW (at 10% harmonic distortion)
load impedance 32 ohms
at DC operation

Outputs
Two HEADPHONES jacks (stereo minijacks)
load impedance 8-300 ohms

Power requirements
3 V DC, two R6 (size AA) batteries
DC IN 3 V jack accepts:
EBP-500 battery case (optional) for use on
two R20 (size D) batteries
AC-D2M AC power adaptor (optional) for use
on 220 V AC, 50 Hz
DCC-70 or DCC-127A car battery cord (optional) for use with 12 V
car battery
(For connection with the DCC-127A, the optional PC-200 DC plug
adaptor is required.)

Battery life

Batteries	Continuous playback hours
Sony batteries SUM-3 (NS)	Approx. 4
Sony alkaline batteries AM3	Approx. 9

For maximum performance we recommend the use of alkaline batteries.

Similar Mechanism Set	WM-DD
Tape Transport Mechanism Type	DD-100

Dimensions

Approx. 79.7 × 110 × 32.8 mm (w/h/d)
 (3 1/4 × 4 3/8 × 1 1/16 inches)
 incl. projecting parts and controls

Weight

Approx. 290 g (10.3 oz) incl. batteries,
 not incl. other accessories

Note: If a car battery cord or an AC power adaptor not manufactured by Sony is used, a fuse must be installed in the battery cord or the AC power adaptor and the polarity of the plug must be as illustrated.

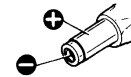

FEATURES

- **Disc Drive system** assures accurate and stable tape transport, greatly reducing wow and flutter.
- **Dolby NR system** reduces tape hiss noise.
- **Tape selector** for optimum playback with standard tapes as well as high-performance tapes.
- **Two HEADPHONES jacks** allow two persons to listen to tape playback together.

STEREO CASSETTE PLAYER

SONY®

Apple Inc., et al.
 Exhibit 1010

Replacing chip components

All chip components should be connected and disconnected, using a tapered soldering iron [temperature of the iron tip: less than 280°C (536°F)], a pair of tweezers and braided wire.

Precautions for replacement

1. Do not disconnect the chip component forcefully. Otherwise, the pattern may peel off.
2. Never re-use a disconnected chip component. Dispose of all old chip components.
3. To protect the chip component, heating time for attaching the component should be within 3 seconds.

○ Removing chip components

(1) Removing solder at electrode

Remove the solder at the electrode, using a thin braided wire. Do not remove the solder of the part (chip component) attached adjacent to the electrode.

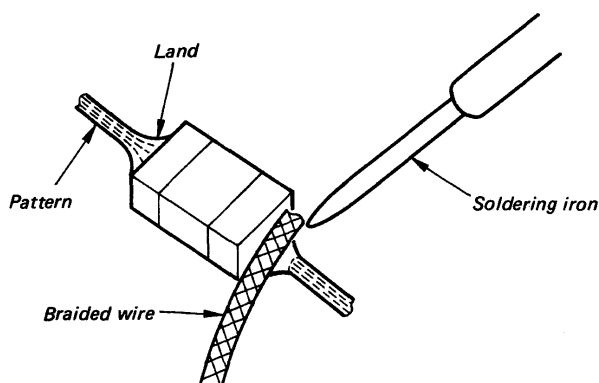

(2) Disconnecting chip components

Turn the tweezers with the soldering iron alternately applied to both electrodes, and the chip component will be disconnected. Take careful precautions while disconnecting, because if the chip component is forcefully removed the land may peel off. Never re-use a disconnected chip component.

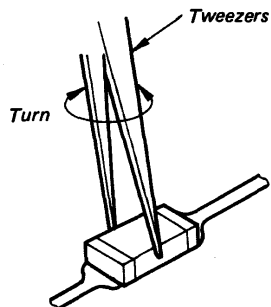

(3) Smoothing the soldered surface

After disconnecting the chip component, remove the solder by using a braided wire to smooth the land surface.

○ Connecting chip components

The value of chip components is not displayed on the main body. Take due precautions to avoid mixing new chip components with other ones.

(1) Applying solder to land on one side

Apply a thin layer of solder to the land on one side where the chip component is to be connected. Too much solder may cause bridging.



(2) Speedy soldering

Hold the chip component at the desired position, using tweezers, and apply the soldering iron in the arrow-marked direction. To protect the chip component, heating time should be within 3 seconds.

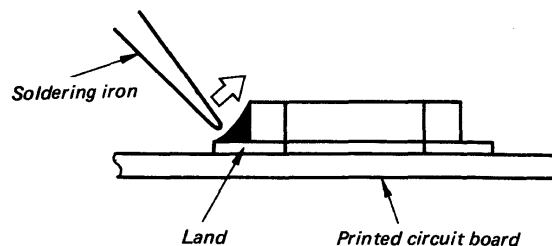

(3) Speedy soldering of electrode on the other side

Solder the electrode on the other side in the same way as in (2) above.

MECHANICAL OPERATION

MECHANICAL OPERATION in this set is the same as that of model WM-DD, so refer to WM-DD service manual previously issued for MECHANICAL OPERATION.

SECTION 2
DISASSEMBLY

Note: Follow the disassembly procedure in the numerical order given.

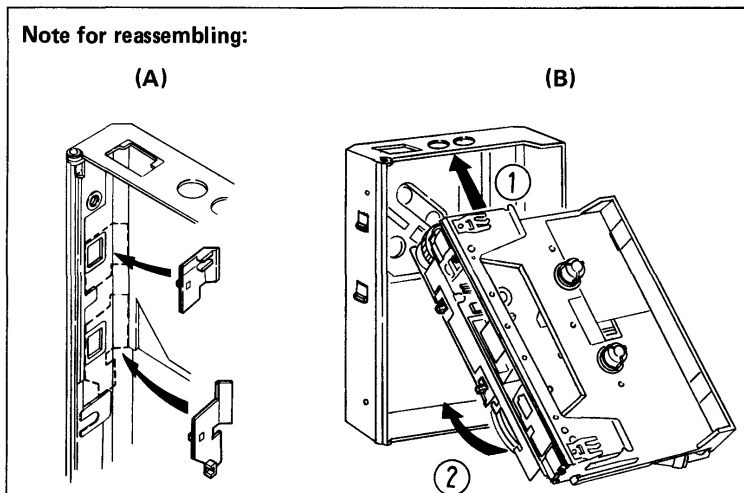
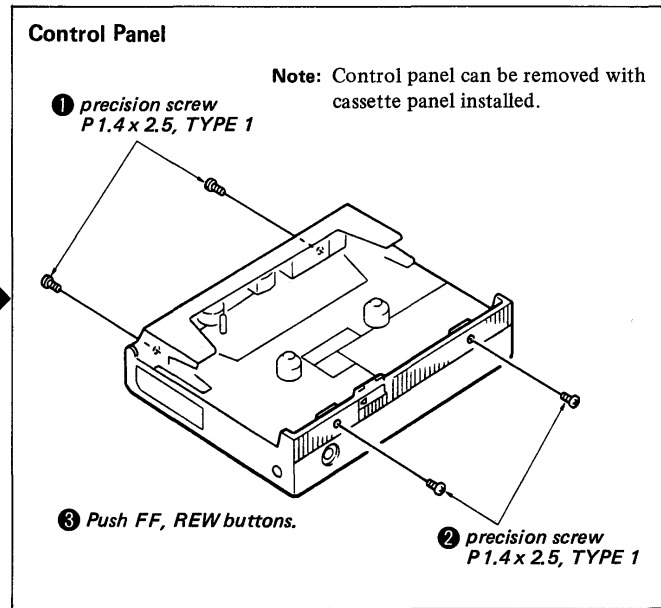
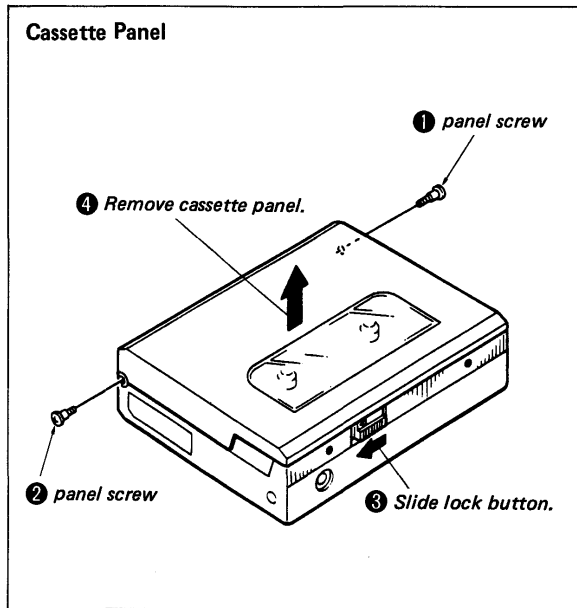

(Installing the compression spring)

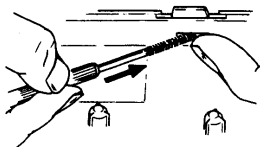

- A) Insert the portion (A) of DOLBY BUTTON and TAPE BUTTON into the slit as shown.
- B) Set the control panel up. Set DOLBY SWITCH and TAPE SWITCH on the main board at OFF position and METAL. Then put the mechanical unit into the control panel following the numbers ① and ②.

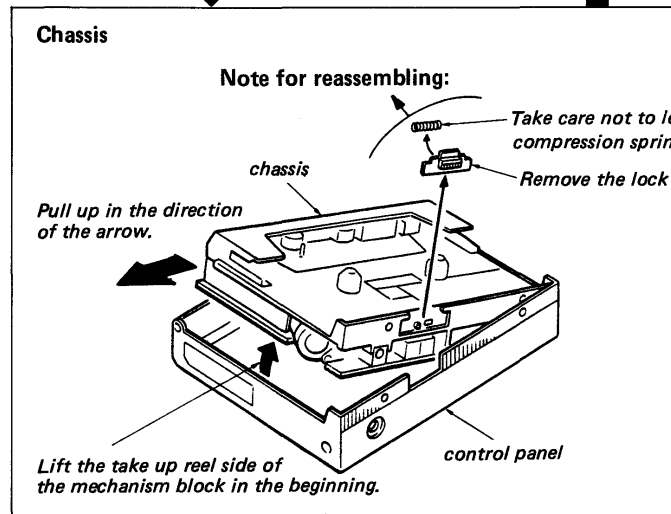

PRECAUTION

- Clean the following parts with a denatured-alcohol-moistened swab:
 playback head pinch roller
 capstan
- Demagnetize the playback head with a head demagnetizer.
- Do not use a magnetized screwdriver for the adjustments.
- After the adjustments, apply suitable locking compound to the parts adjusted.
- The adjustments should be performed with the rated power supply voltage unless otherwise noted.

3-1. MECHANICAL ADJUSTMENT

Torque Measurement

Perform with 2.5 V DC power.

	Torque meter	Meter reading
FWD	CQ-102C	22 – 46 g·cm (0.3 – 0.63 oz·inch)
FF, REW	CQ-201B	More than 65 g·cm (More than 9.04 oz·inch)
Back Tension	CQ-102C	1 – 3.5 g·cm (0.01 – 0.05 oz·inch)
Tape Pulling Force	CQ-403	More than 80 g·cm (More than 11.12 oz·inch)

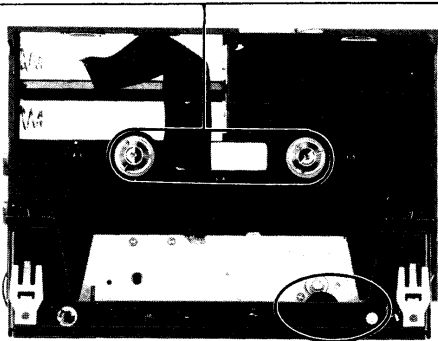

Pinch Roller Pressure Adjustment

— Playback Mode —

- Pull the spring scale in the direction shown by the arrow.
- Slowly return the pinch roller and read the spring scale just when the pinch roller starts rotating.

Specification:

170 ± 20 g (5.3 ~ 6.7 oz)

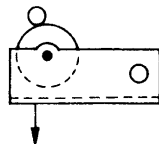

Head Height Adjustment

- Prepare an adjustment cassette as shown below.

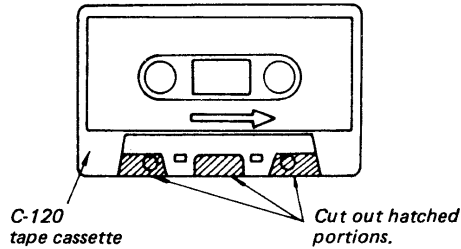

- In playback mode and viewing from the front, adjust the head heights to eliminate tape curl and tape twist at portions shown by the arrow.

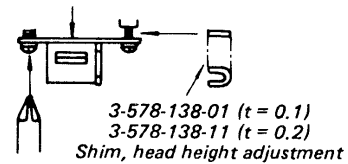
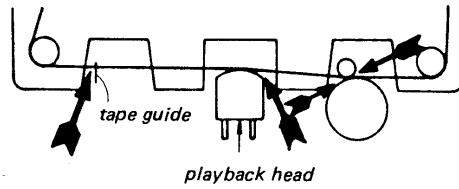

- If necessary, adjust the height of the tape-guide by turning the adjustment screw.

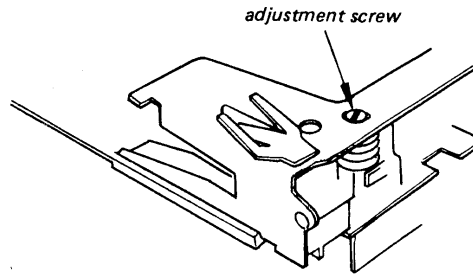

- Apply locking compound on adjustment screw.

1. Motor section installation

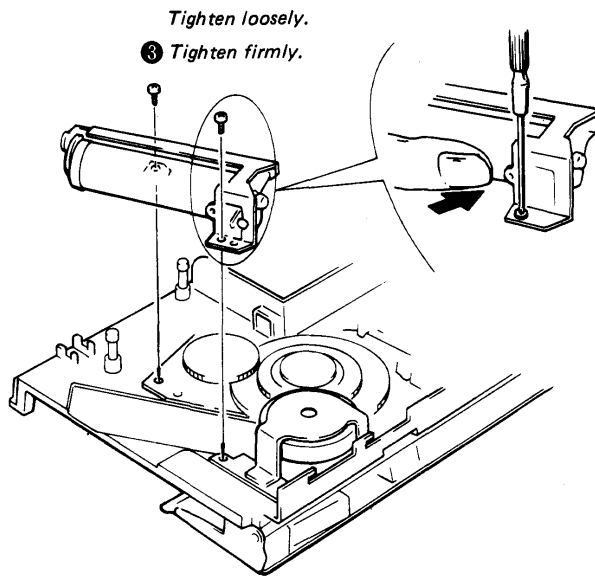

- ① Tighten screw loosely.
- ② Tighten screw while pressing the motor section lightly in the direction of the arrow.
- ③ Tighten the screw.

2. Wow & flutter and motor position

1. Adjust with the adjustment screw so that rotor thrust play is within 0.1mm. (When confirming play, press motor down so that the motor pulley and rotor rubber section do not touch.)
2. Wow & flutter adjustment

Setting:

Power supply voltage: 2.5V
 Tape: Adjust by using end portion of tape.
 VOLUME control: mechanical mid
 TAPE SELECT switch: NORM
 DOLBY NR switch: OFF

Procedure:

- ① Mode: playback

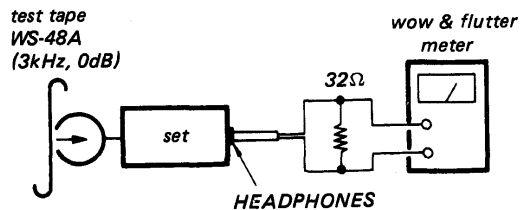

Turn the adjustment screw so that the wow and flutter meter reads minimum (less than 0.12% W.RMS).

- ② At 2V power supply voltage, confirm normal FWD operation.
- ③ When ① and ② are not satisfied, repeat adjustment again starting with "Motor Section Installation".

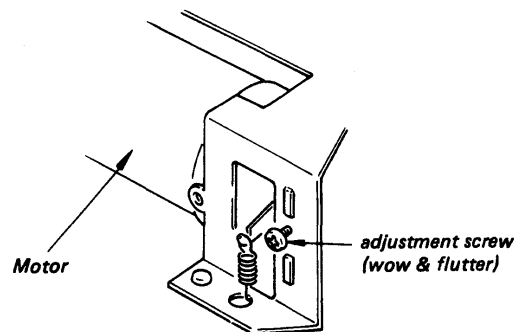
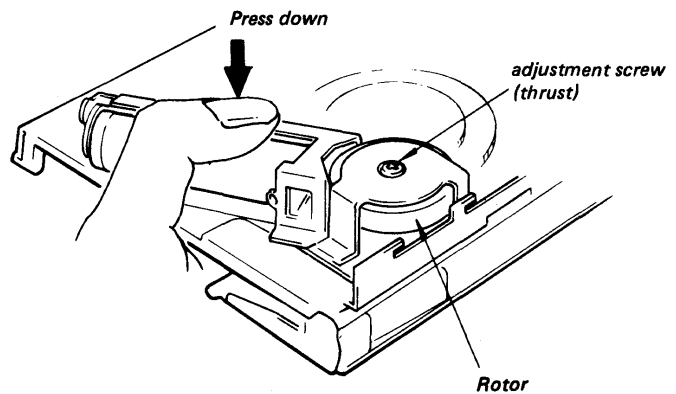

Explore Litigation Insights

Docket Alarm provides insights to develop a more informed litigation strategy and the peace of mind of knowing you're on top of things.

Real-Time Litigation Alerts



Keep your litigation team up-to-date with **real-time alerts** and advanced team management tools built for the enterprise, all while greatly reducing PACER spend.

Our comprehensive service means we can handle Federal, State, and Administrative courts across the country.

Advanced Docket Research



With over 230 million records, Docket Alarm's cloud-native docket research platform finds what other services can't. Coverage includes Federal, State, plus PTAB, TTAB, ITC and NLRB decisions, all in one place.

Identify arguments that have been successful in the past with full text, pinpoint searching. Link to case law cited within any court document via Fastcase.

Analytics At Your Fingertips



Learn what happened the last time a particular judge, opposing counsel or company faced cases similar to yours.

Advanced out-of-the-box PTAB and TTAB analytics are always at your fingertips.

API

Docket Alarm offers a powerful API (application programming interface) to developers that want to integrate case filings into their apps.

LAW FIRMS

Build custom dashboards for your attorneys and clients with live data direct from the court.

Automate many repetitive legal tasks like conflict checks, document management, and marketing.

FINANCIAL INSTITUTIONS

Litigation and bankruptcy checks for companies and debtors.

E-DISCOVERY AND LEGAL VENDORS

Sync your system to PACER to automate legal marketing.