

[54] MEMBRANE SWITCH

[76] Inventor: Robert F. Phalen, 1612 W. North Ave., Chicago, Ill. 60622

[21] Appl. No.: 739,544

[22] Filed: May 30, 1985

[51] Int. Cl.<sup>4</sup> ..... H01H 13/70

[52] U.S. Cl. .... 200/5 A; 200/86 R; 200/159 B

[58] Field of Search ..... 200/5 A, 86 R, 159 B, 200/292, 308

[56] References Cited

U.S. PATENT DOCUMENTS

3,699,294	10/1972	Sudduth	.....	200/86 R X
4,017,697	4/1977	Larson	.....	200/5 A
4,085,302	4/1978	Zenk et al.	.....	200/5 A
4,317,013	2/1982	Larson	.....	200/5 A
4,365,130	12/1982	Christensen	.....	200/5 A X
4,385,215	5/1983	Lemberg	.....	200/5 A
4,471,177	9/1984	Doughty	.....	200/5 A X
4,525,606	6/1985	Sudo	.....	200/5 A

Primary Examiner—J. R. Scott  
Attorney, Agent, or Firm—Robert M. Ward

[57] ABSTRACT

The present invention is directed to an improved mem-

brane switch of the kind comprising a polymeric overlay, which is generally planar and containing designated switch areas thereon for manual operation by pressure. The switch is formed from several layers of conductive and nonconductive materials. Specifically, the switch includes a pair of electronic switch circuit leads disposed in noncontacting proximity. A substantially planar circuit completing layer formed to correspond with the pair of switch circuit leads is formed from conductive material and disposed and spaced array substantially parallel to the switch circuit leads. A nonconductive spacer is disposed, in one preferred embodiment, between the electric circuit and the circuit completing layer, with the spacer having a plurality of apertures therein of a selected density sufficient to provide a selected touch pressure. In another preferred embodiment, the substantially planar circuit completing layer is omitted, and the pair of electronic switch circuit leads are instead disposed in separate planes and are separated by the spacer, such that manual pressure on the switch will contact one circuit lead with the other circuit lead through the apertures in the spacer.

11 Claims, 8 Drawing Figures

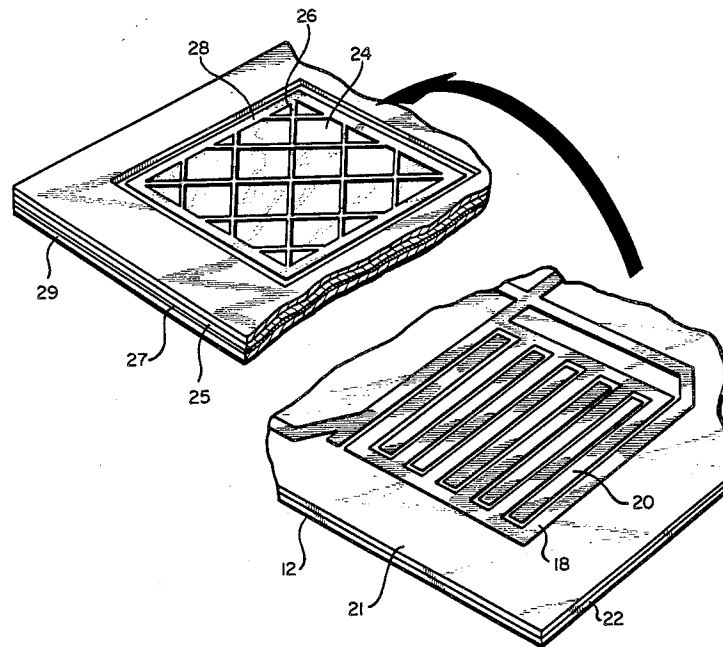

FIG. 1

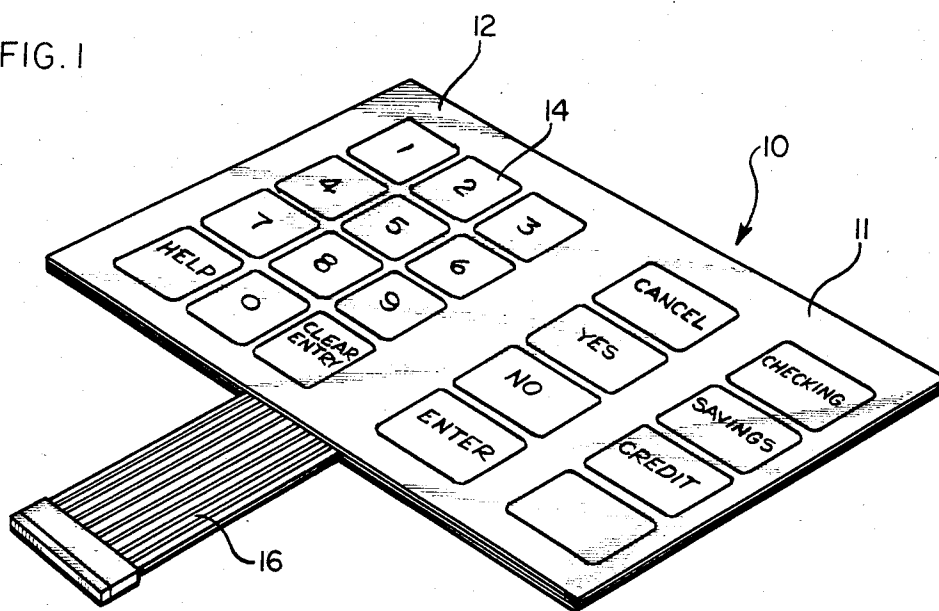

FIG. 2

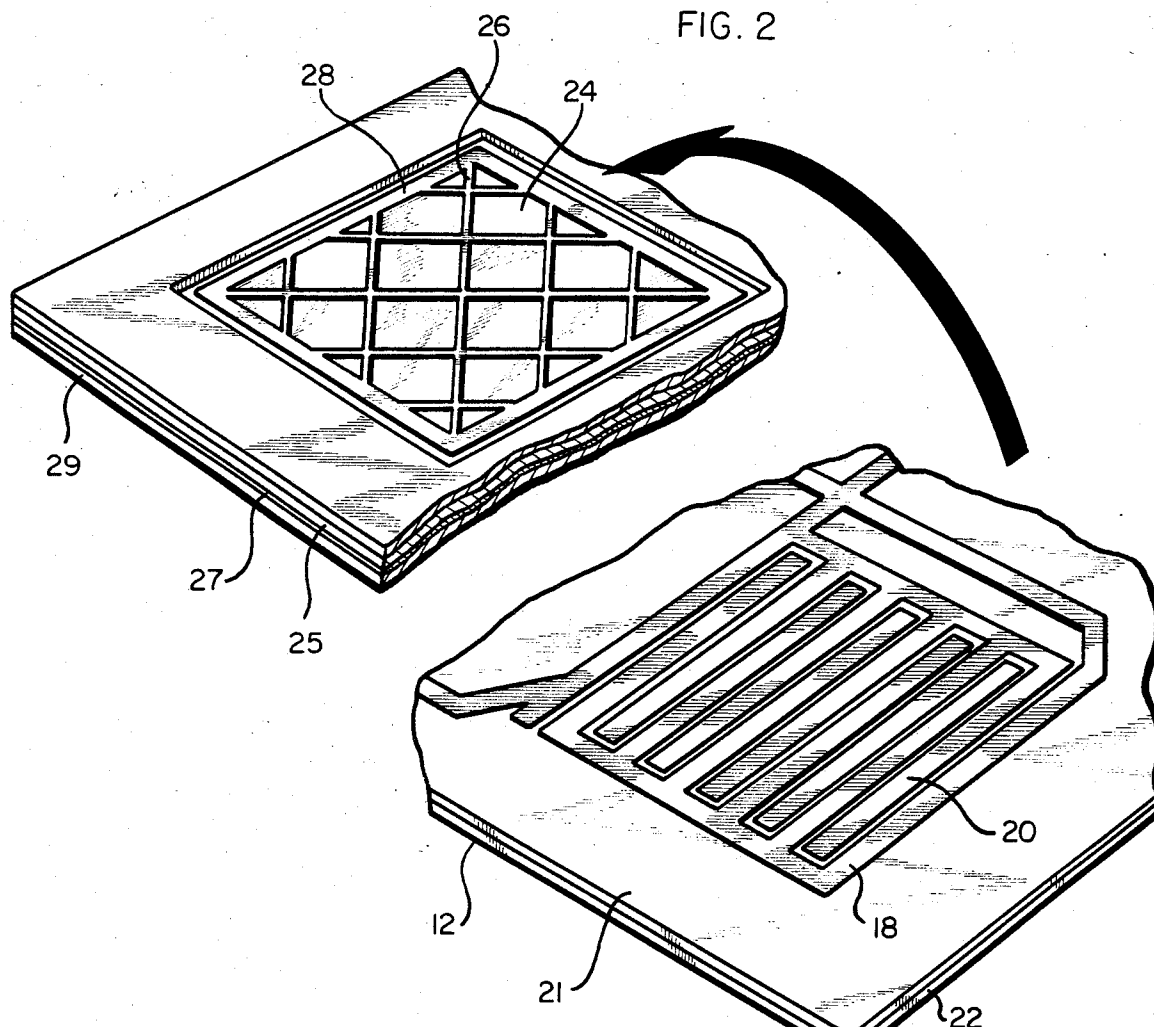

FIG. 3

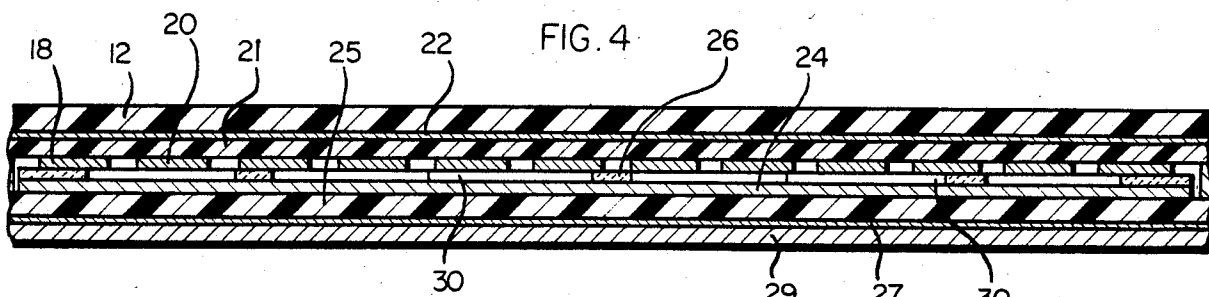
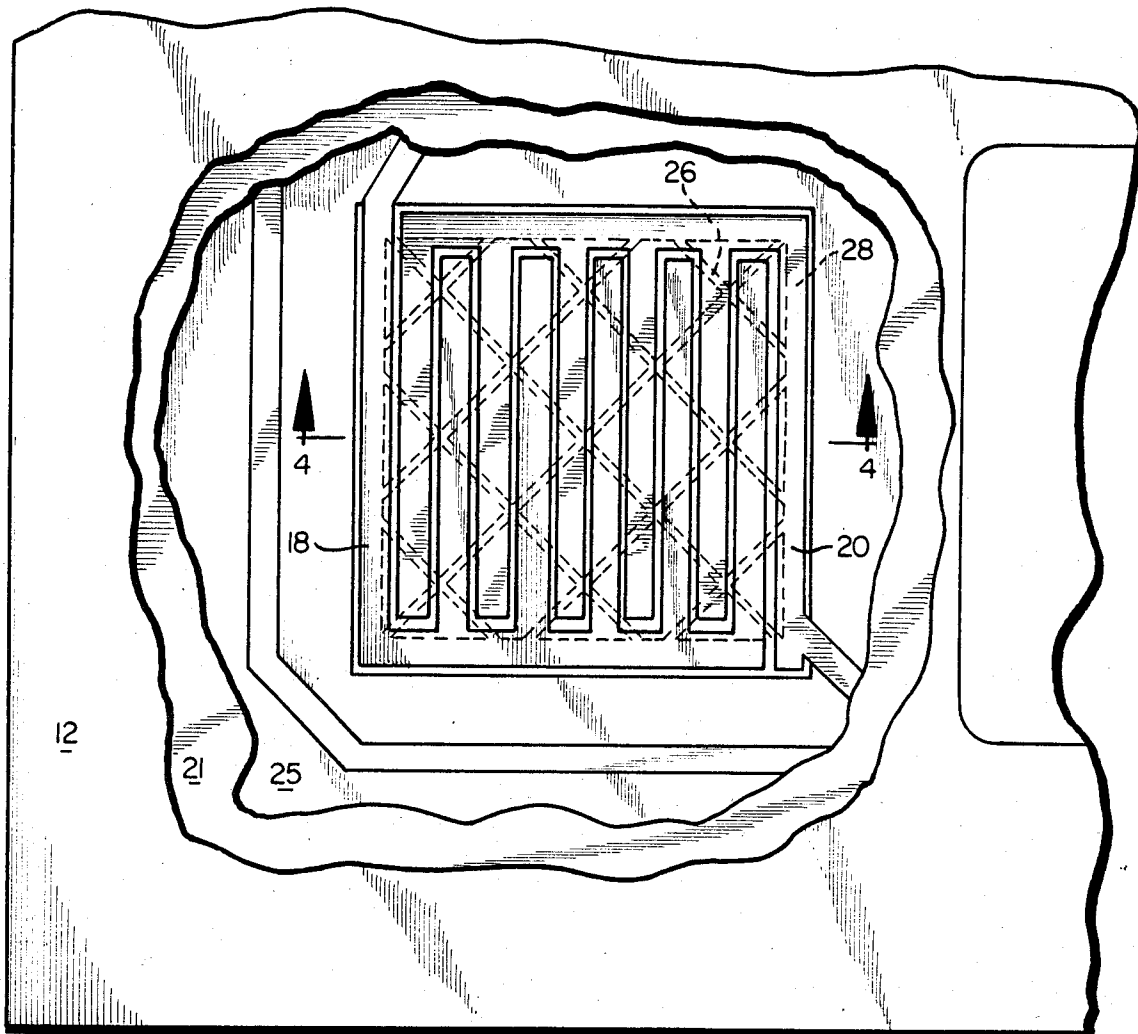
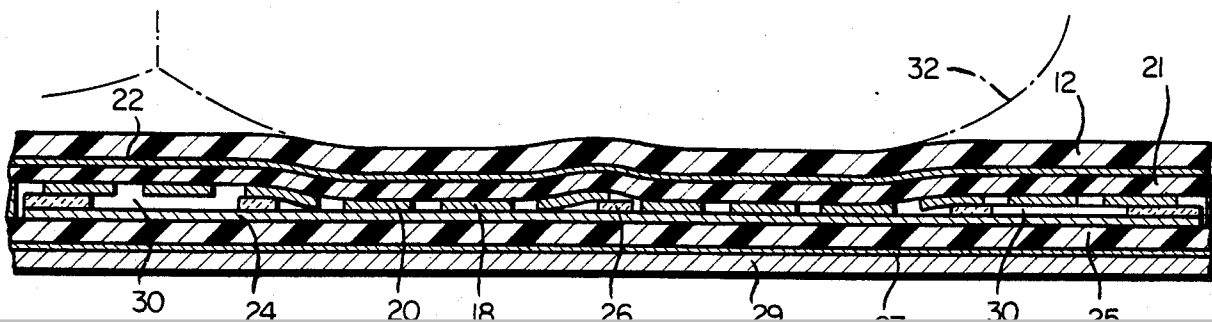
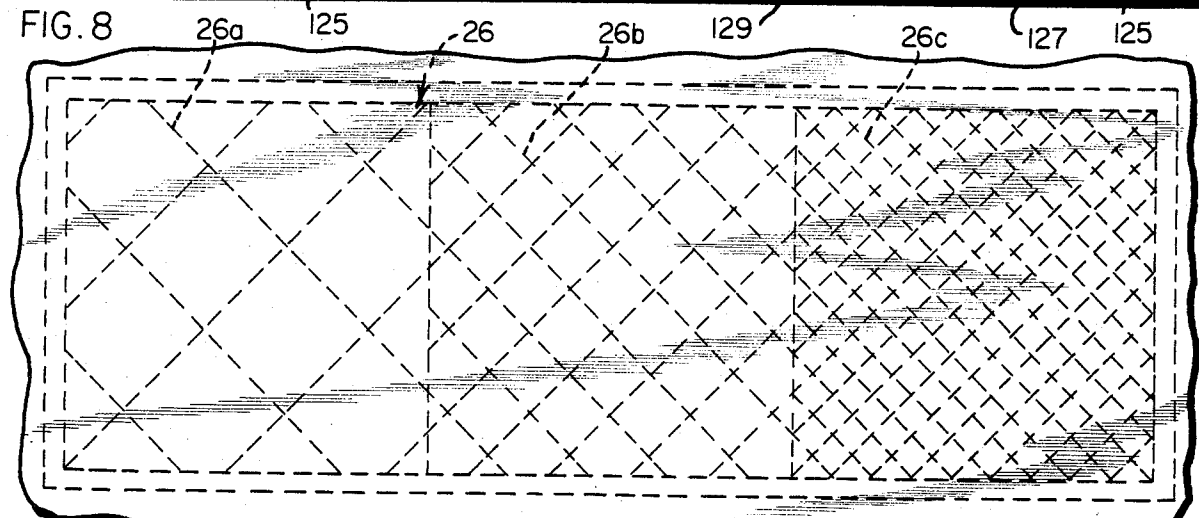
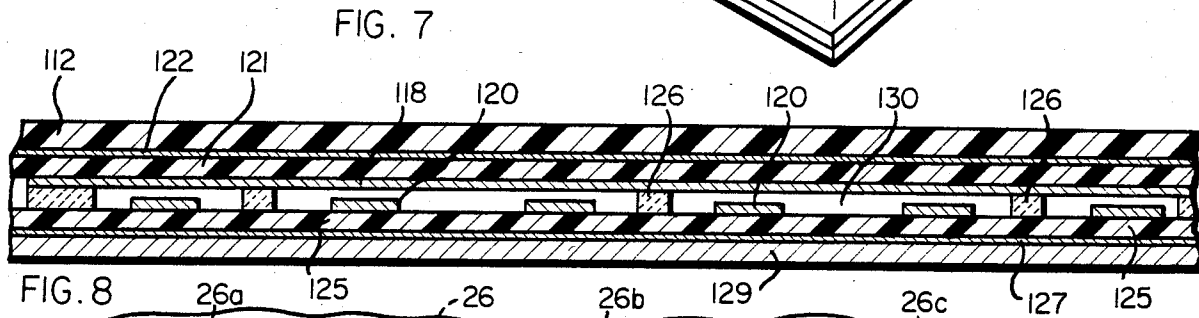
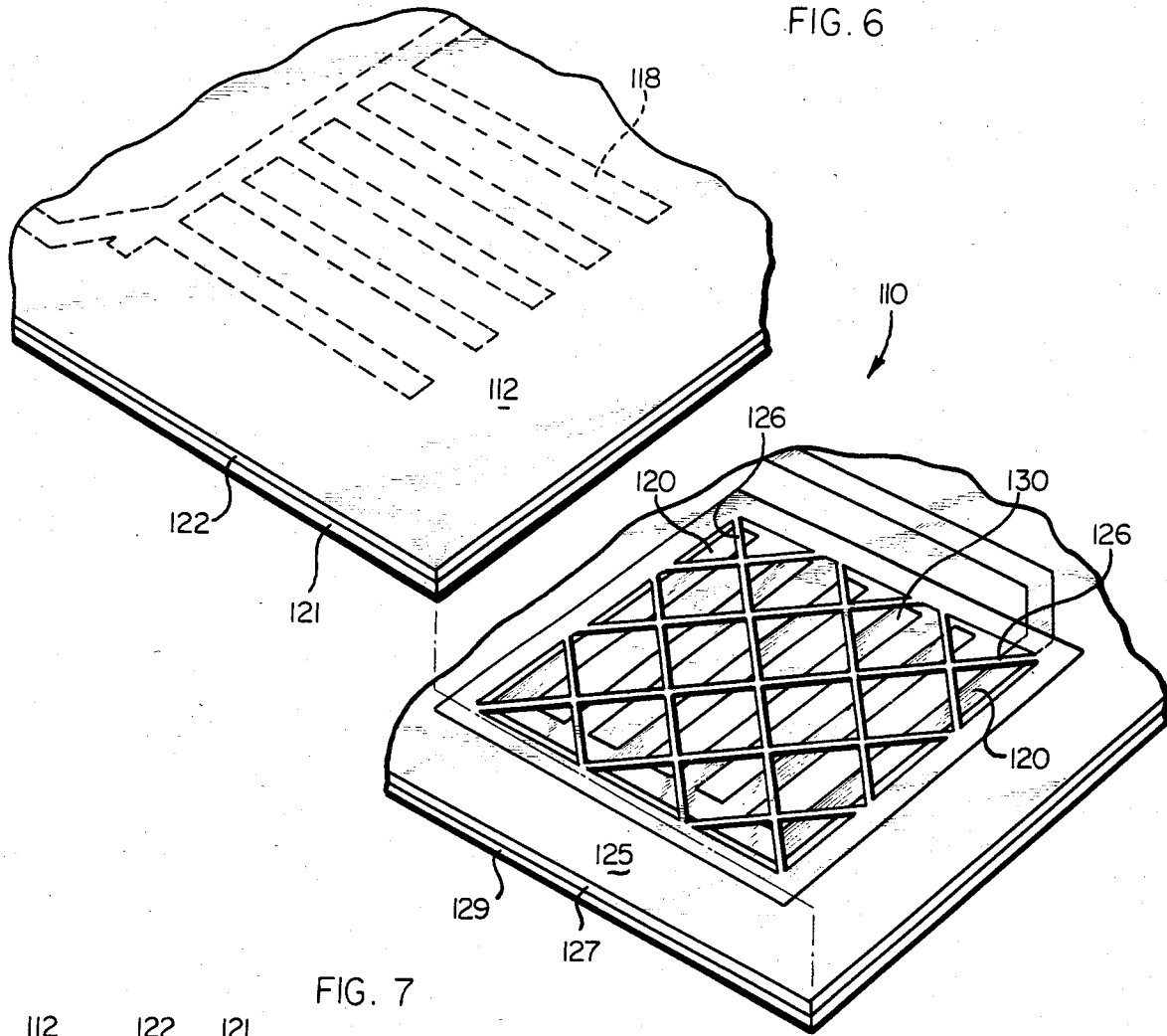

FIG. 5





## MEMBRANE SWITCH

### BACKGROUND OF THE INVENTION

The present invention relates generally to switches, and more particularly to an improved membrane switch.

In the prior art, various types of membrane switches have been utilized on machinery panels, calculators, computers, etc. Such membrane switches have the advantage over other forms of switches that they present a substantially flat upper surface, and are relatively very thin as compared with mechanical switches. Also, such membrane switches are enclosed, and contain very few moving parts. Accordingly, such membrane switches have had exceeding long useful lives.

One difficulty with prior art membrane switches has been the inability to control selectively the amount of pressure necessary to operate this type of switch. Also, another difficulty with prior art switches has been frequently the necessity for switches requiring different manual pressures on the same or different switch panels. Also, the prior switches have had the further difficulty of an inability to provide different operating pressures within the same switch.

Thus, in view of the difficulties and deficiencies with prior art membrane switches, it is an object of the improved membrane switch of the present application to materially alleviate such difficulties and deficiencies.

### SUMMARY OF THE INVENTION

The improved membrane switch of the present invention concerns switches having a top sheet with portions designated thereon for manual pushing to operate the switch.

The improved membrane switch of the present invention comprises a pair of electronic switch circuit leads which are disposed in noncontacting and mutually relative proximity. A substantially planar circuit completing means, the size and shape corresponding with at least a portion of the electronic switch circuit leads, is formed from a conductive material and is disposed in spaced array and substantially parallel to the switch circuits.

A spacer means of a nonconductive material is disposed between the pair of electronic circuit leads and the circuit completing means. The spacer means has a plurality of apertures therein of a selected density sufficient to provide a selected touch pressure for pushing portions of the circuit completing means which appear through apertures in the spacer into contact with portions of the pair of electronic switch circuit leads to complete the circuit and to operate the switch.

In an alternative preferred embodiment, the electronic switch circuit leads are disposed in separate planes and substantially parallel to each other and are separated by the spacer means. In such embodiment, the electronic circuit leads are disposed opposite each other, such that sufficient manual pressure on the switch disposes the electronic switch leads into contact with each other through the apertures in the spacer means to operate the switch. In this embodiment also, the density and location of the apertures controls the amount of pressure necessary to operate the switch.

In both of the above embodiments, the manual pressure necessary to operate the switch may be varied in switches on the same switch panel, or even in portions

of the same discrete membrane switch, by varying the size and density of the apertures in the spacer means.

The improved membrane switch of the present invention will be better understood with reference to the following brief description of the drawing, detailed description of preferred embodiments, the appended claims, and the accompanying drawing.

### BRIEF DESCRIPTION OF THE DRAWING

Preferred embodiments of the improved membrane switch apparatus of the present invention are set forth in the accompanying drawing, and in which:

FIG. 1 is a perspective view of an exemplary membrane switch panel setting forth discrete areas containing visual indicia for designating and defining portions of the panel to receive manual pressure for operating an electronic improved membrane switch disposed therebeneath;

FIG. 2 is a greatly enlarged, fragmented view of the improved membrane switch of the present invention, shown in peeled-apart array, and illustrating the inter-twining, but noncontacting, electronic switch circuit leads, and the facing nonconductive, grid-like spacer means disposed atop the substantially planar circuit completing means formed from a conductive material;

FIG. 3 is a greatly enlarged top view of the improved membrane switch of the present invention, with layers of the electronic panel cut away to illustrate the disposition of circuit completing means, and spacer means (in phantom) disposed atop the pair of electronic switch circuit leads;

FIG. 4 is an even further enlarged, fragmented side view taken along lines 4—4 of FIG. 3, and illustrating the various layers comprising the improved membrane switch of the present invention;

FIG. 5 is the view of the present invention as shown in FIG. 4 showing manual pressure being applied thereto to operate the switch;

FIG. 6 is an enlarged fragmentary view of an alternative preferred embodiment of the improved membrane switch of the present invention illustrating the electronic switch circuit leads being disposed in separate planes, with the grid-like spacer means of nonconductive material disposed therebetween, such that manual pressure on the switch will contact one electronic lead with the other, and through the apertures in the grid of the spacer means to operate this switch;

FIG. 7 is a greatly enlarged, and fragmented side view of the alternative preferred embodiment of the improved membrane switch of FIG. 6; and

FIG. 8 is a greatly enlarged, and fragmentary top view of the spacer means layer of the improved membrane switch of the present invention illustrating different densities of the grid-like spacer means, which can be utilized in different individual switches, or which may be utilized in different portions of the same switch.

### DETAILED DESCRIPTION OF THE PREFERRED EMBODIMENTS

The improved membrane switch of the present invention has a top sheet with portions designated by visual indicia thereon for manual pushing to operate the switch. The improved membrane switch of the present invention includes a pair of electronic switch circuit leads which are disposed in noncontacting, and mutually relative proximity. A substantially planar circuit completing means has a size and shape to correspond with at least a portion of the pair of switch circuit leads.



# Explore Litigation Insights

Docket Alarm provides insights to develop a more informed litigation strategy and the peace of mind of knowing you're on top of things.

## Real-Time Litigation Alerts



Keep your litigation team up-to-date with **real-time alerts** and advanced team management tools built for the enterprise, all while greatly reducing PACER spend.

Our comprehensive service means we can handle Federal, State, and Administrative courts across the country.

## Advanced Docket Research



With over 230 million records, Docket Alarm's cloud-native docket research platform finds what other services can't. Coverage includes Federal, State, plus PTAB, TTAB, ITC and NLRB decisions, all in one place.

Identify arguments that have been successful in the past with full text, pinpoint searching. Link to case law cited within any court document via Fastcase.

## Analytics At Your Fingertips



Learn what happened the last time a particular judge, opposing counsel or company faced cases similar to yours.

Advanced out-of-the-box PTAB and TTAB analytics are always at your fingertips.

## API

Docket Alarm offers a powerful API (application programming interface) to developers that want to integrate case filings into their apps.

## LAW FIRMS

Build custom dashboards for your attorneys and clients with live data direct from the court.

Automate many repetitive legal tasks like conflict checks, document management, and marketing.

## FINANCIAL INSTITUTIONS

Litigation and bankruptcy checks for companies and debtors.

## E-DISCOVERY AND LEGAL VENDORS

Sync your system to PACER to automate legal marketing.