

ORACLE EXHIBIT 1002

PART 1

TO: Mail Stop 8 Director of the U.S. Patent and Trademark Office P.O. Box 1450 Alexandria, VA 22313-1450	REPORT ON THE FILING OR DETERMINATION OF AN ACTION REGARDING A PATENT OR TRADEMARK
-----------------------------------------------------------------------------------------------------------------------------------------------	-------------------------------------------------------------------------------------------------------------------------

In Compliance with 35 U.S.C. § 290 and/or 15 U.S.C. § 1116 you are hereby advised that a court action has been filed in the U.S. District Court Western District of Texas, Austin Division on the following

Trademarks or Patents. (the patent action involves 35 U.S.C. § 292.):

DOCKET NO. 1:14-cv-00148	DATE FILED 2/18/2014	U.S. DISTRICT COURT Western District of Texas, Austin Division
PLAINTIFF CROSSROADS SYSTEMS, INC.		DEFENDANT CISCO SYSTEMS, INC.
PATENT OR TRADEMARK NO.	DATE OF PATENT OR TRADEMARK	HOLDER OF PATENT OR TRADEMARK
1 U.S. 6,425,035 B2	7/23/2002	Geoffrey B. Hoese & Jeffry T. Russell
2 U.S. 7,934,041 B2	4/26/2011	Geoffrey B. Hoese & Jeffry T. Russell
3		
4		
5		

In the above—entitled case, the following patent(s)/ trademark(s) have been included:

DATE INCLUDED	INCLUDED BY <input checked="" type="checkbox"/> Amendment <input type="checkbox"/> Answer <input type="checkbox"/> Cross Bill <input type="checkbox"/> Other Pleading
PATENT OR TRADEMARK NO.	DATE OF PATENT OR TRADEMARK
1	
2	<i>see attached</i>
3	
4	
5	

In the above—entitled case, the following decision has been rendered or judgement issued:

DECISION/JUDGEMENT

CLERK WILLIAM G. PUTNICKI	(BY) DEPUTY CLERK <i>Lerika Stumma</i>	DATE 4-15-14
------------------------------	-------------------------------------------	-----------------

Copy 1—Upon initiation of action, mail this copy to Director Copy 3—Upon termination of action, mail this copy to Director
 Copy 2—Upon filing document adding patent(s), mail this copy to Director Copy 4—Case file copy

- N. That Crossroads receive enhanced damages from Defendant in the form of treble damages, pursuant to 35 U.S.C. § 284 based on Defendant's willful infringement of the '147 Patent;
- O. That Crossroads be granted pre-judgment and post-judgment interest on the damages caused to it by reason of Defendant's infringement of the '147 Patent, including pre-judgment and post-judgment interest on any enhanced damages or attorneys' fees award;
- P. That Defendant pay Crossroads all of Crossroads' reasonable attorneys' fees and expenses;
- Q. That costs be awarded to Crossroads;
- R. That Defendant, its agents, employees, representatives, successors and assigns, and those acting in privity or in concert with it, be preliminarily and permanently enjoined from further infringement of the '035 Patent;
- S. That Defendant, its agents, employees, representatives, successors and assigns, and those acting in privity or in concert with it, be preliminarily and permanently enjoined from further infringement of the '041 Patent;
- T. That Defendant, its agents, employees, representatives, successors and assigns, and those acting in privity or in concert with it, be preliminarily and permanently enjoined from further infringement of the '147 Patent;
- U. That this is an exceptional case under 35 U.S.C. § 285; and
- V. That Crossroads be granted such other and further relief as the Court may deem just and proper under the circumstances.

Dated: April 15, 2014

Respectfully submitted,

By: /s/ Susan K. Knoll
Steven Sprinkle
Texas Bar No. 00794962
Elizabeth J. Brown Fore
Texas Bar No. 24001795
Sprinkle IP Law Group, PC
1301 W. 25th Street, Suite 408
Austin, Texas 78705
Tel: 512-637-9220
Fax: 512-371-9088
ssprinkle@sprinklelaw.com
ebrownfore@sprinklelaw.com

Susan K. Knoll
Texas Bar No. 11616900
Russell T. Wong
Texas Bar No. 21884235
James H. Hall
Texas Bar No. 24041040
Stephen D. Zinda
Texas Bar No. 24084147
WONG, CABELLO, LUTSCH,
RUTHERFORD & BRUCCULERI, L.L.P.
20333 SH 249, Suite 600
Houston, TX 77070
Tel: 832-446-2400
Fax: 832-446-2424
sknoll@counselip.com
rwong@counselip.com
jhall@counselip.com
szinda@counselip.com

*ATTORNEYS FOR PLAINTIFF
CROSSROADS SYSTEMS, INC.*

CERTIFICATE OF SERVICE

I certify that on April 15, 2014, I electronically filed the foregoing with the Clerk of Court using the CM/ECF system, which will send notification of such filing to all CM/ECF participants.

/s/ Lynn Marlin

IN THE UNITED STATES DISTRICT COURT
FOR THE WESTERN DISTRICT OF TEXAS
AUSTIN DIVISION

CROSSROADS SYSTEMS, INC.,	§	
	§	
Plaintiff,	§	
	§	CIVIL ACTION NO. 1:14-cv-00148
v.	§	
	§	JURY DEMANDED
CISCO SYSTEMS, INC.,	§	
	§	
Defendant.	§	

**PLAINTIFF CROSSROADS SYSTEMS, INC.'S
FIRST AMENDED COMPLAINT FOR PATENT INFRINGEMENT**

THE PARTIES

1. Pursuant to Federal Rule of Civil Procedure 15(a)(1)(B), Plaintiff Crossroads Systems, Inc. (“Crossroads”) hereby submits its First Amended Complaint for Patent Infringement as a matter of course within 21 days after service of Cisco System, Inc.’s Answer and Affirmative Defenses (Dkt. No. 22).

2. Crossroads is a corporation incorporated under the laws of the State of Delaware and has its principal place of business at 11000 North MoPac Expressway, Austin, Texas 78759.

3. Upon information and belief, Defendant Cisco Systems, Inc. (“Defendant” or “Cisco”) is a California corporation with a principal place of business of 170 West Tasman Dr., San Jose, California 95134.

JURISDICTION AND VENUE

3. This action arises under the laws of the United States, more specifically under 35 U.S.C. § 100, *et seq.* Subject matter jurisdiction is proper in this Court pursuant to 28 U.S.C. §§ 1331 and 1338.

4. Personal jurisdiction and venue are proper in this district under 28 U.S.C. §§ 1391 and 1400(b). Upon information and belief, Defendant Cisco has established minimum contacts with this forum such that the exercise of jurisdiction over Defendant would not offend traditional notions of fair play and substantial justice.

5. This Court has personal jurisdiction over Cisco. Upon information and belief, Cisco regularly conducts business in the State of Texas and in this judicial district and is subject to the jurisdiction of this Court. Upon information and belief, Cisco has been doing business in Texas and this judicial district by distributing, marketing, selling and/or offering for sale its products, including, but not limited to, products that practice the subject matter claimed in United States Patent Nos. 6,425,035 (“the ’035 Patent”), 7,934,041 (“the ’041 Patent”) and 7,051,147 (“the ’147 Patent”) (collectively “the Patents-In-Suit”) and/or regularly doing or soliciting business and/or engaging in other persistent courses of conduct in and/or directed to Texas and this judicial district.

COUNT 1: INFRINGEMENT OF U.S. PATENT NO. 6,425,035

6. Crossroads incorporates by reference the allegations set forth in the preceding paragraphs.

7. On July 23, 2002, the ’035 Patent was duly and legally issued. A true and correct copy of the ’035 Patent is attached hereto as Exhibit A. Crossroads is the assignee and the owner of all right, title, and interest in and to the ’035 Patent. The ’035 Patent is entitled to a presumption of validity.

8. On information and belief, Defendant has directly infringed the ’035 Patent. On information and belief, Defendant continues to directly infringe the ’035 Patent.

9. Specifically, on information and belief, Defendant has directly infringed the '035 Patent by making, using, offering for sale, selling and/or importing into the United States certain of its products including at least the following: Cisco MDS 9200 Series Switches and Cisco MDS 9500 Series Multi-Layer Directors with compatible modules providing iSCSI interfaces (including but not limited to Cisco's 18/4-Port Multiservice Module), Cisco MDS 9500 Series Multi-Layer Directors with compatible modules providing FC interfaces (including but not limited to 1/2/4/8 Gbps 48 Port FC Switching Module, 1/2/4/8 Gbps 24 Port FC Switching Module, 1/2/4/8 Gbps 4/44 Port Host Optimized FC Switching Module, 4 Port 10 Gbps FC Switching Module), Cisco MDS 9200 Series Switches (including but not limited to MDS 9222i, MDS 9216A, MDS 9216i), Cisco MDS 9134 Multilayer Fabric Switches, Cisco MDS 9124 Multilayer Fabric Switch, Cisco MDS Fibre Channel Blade Switches, Cisco Invicta C312SA Appliance, Cisco UCS Invicta Scaling System (hereinafter "the Accused Products").

10. Further, on information and belief, Defendant has been and now is indirectly infringing by way of inducing infringement of the '035 Patent with knowledge of the '035 Patent by making, offering for sale, selling, importing into the United States, marketing, supporting, providing product instruction and/or advertising certain of its products, including the Accused Products, and Defendant knew that its actions were inducing end users to infringe the '035 Patent.

11. Further, on information and belief, Defendant has been and now is indirectly infringing by way of contributing to the infringement by end users of the '035 Patent by selling, offering to sell and/or importing into the United States components, including the Accused Products, knowing the components to be especially made or especially adapted for use in the

infringement of the '035 Patent. Such components are not a staple article or commodity of commerce suitable for substantial non-infringing uses.

12. Defendant has been on constructive and/or actual notice of the '035 Patent since at least as early as October 2002, and Defendant has not ceased its infringing activities. The infringement of the '035 Patent by Defendant has been and continues to be willful and deliberate.

13. Crossroads has been irreparably harmed by Defendant's acts of infringement of the '035 Patent, and will continue to be harmed unless and until Defendant's acts of infringement are enjoined and restrained by order of this Court.

14. As a result of the acts of infringement of the '035 Patent by Defendant, Crossroads has suffered and will continue to suffer damages in an amount to be proven at trial.

COUNT 2: INFRINGEMENT OF U.S. PATENT NO. 7,934,041

15. Crossroads incorporates by reference the allegations set forth in the preceding paragraphs.

16. On April 26, 2011, the '041 Patent was duly and legally issued. A true and correct copy of the '041 Patent is attached hereto as Exhibit B. Crossroads is the assignee and the owner of all right, title, and interest in and to the '041 Patent. The '041 Patent is entitled to a presumption of validity.

17. On information and belief, Defendant has directly infringed the '041 Patent. On information and belief, Defendant continues to directly infringe the '041 Patent.

18. Specifically, on information and belief, Defendant has directly infringed the '041 Patent by making, using, offering for sale, selling and/or importing into the United States certain of its products including at least the Accused Products.

19. Further, upon information and belief, Defendant has been and now is indirectly infringing by way of inducing infringement of the '041 Patent with knowledge of the '041 Patent by making, offering for sale, selling, importing into the United States, marketing, supporting, providing product instruction and/or advertising certain of its products, including the Accused Products, and Defendant knew that its actions were inducing end users to infringe the '041 Patent.

20. Further, upon information and belief, Defendant has been and now is indirectly infringing by way of contributing to the infringement by end users of the '041 Patent by selling, offering to sell and/or importing into the United States components, including the Accused Products, knowing the components to be especially made or especially adapted for use in the infringement of the '041 Patent. Such components are not a staple article or commodity of commerce suitable for substantial non-infringing uses.

21. Defendant has been on constructive and/or actual notice of the '041 Patent since at least as early as May 2011, and Defendant has not ceased its infringing activities. The infringement of the '041 Patent by Defendant has been and continues to be willful and deliberate.

22. Crossroads has been irreparably harmed by Defendant's acts of infringement of the '041 Patent, and will continue to be harmed unless and until Defendant's acts of infringement are enjoined and restrained by order of this Court.

23. As a result of the acts of infringement of the '041 Patent by Defendant, Crossroads has suffered and will continue to suffer damages in an amount to be proven at trial.

COUNT 3: INFRINGEMENT OF U.S. PATENT NO. 7,051,147

24. Crossroads incorporates by reference the allegations set forth in the preceding paragraphs.

25. On May 23, 2006, the '147 Patent was duly and legally issued. A true and correct copy of the '147 Patent is attached hereto as Exhibit C. Crossroads is the assignee and the owner of all right, title, and interest in and to the '147 Patent. The '147 Patent is entitled to a presumption of validity.

26. On information and belief, Defendant has directly infringed the '147 Patent. On information and belief, Defendant continues to directly infringe the '147 Patent.

27. Specifically, on information and belief, Defendant has directly infringed the '147 Patent by making, using, offering for sale, selling and/or importing into the United States certain of its products including at least: Cisco MDS 9500 Series Multi-Layer Directors with compatible modules providing FC interfaces (including but not limited to 1/2/4/8 Gbps 48 Port FC Switching Module, 1/2/4/8 Gbps 24 Port FC Switching Module, 1/2/4/8 Gbps 4/44 Port Host Optimized FC Switching Module, 4 Port 10 Gbps FC Switching Module,), Cisco MDS 9200 Series Switches (including but not limited to MDS 9222i, MDS 9216A, MDS 9216i), Cisco MDS 9134 Multilayer Fabric Switches, Cisco MDS 9124 Multilayer Fabric Switches, Cisco Fibre Channel Blade Switches (hereinafter "the Accused Fibre-to-Fibre Products").

28. Further, upon information and belief, Defendant has been and now is indirectly infringing by way of inducing infringement of the '147 Patent with knowledge of the '147 Patent by making, offering for sale, selling, importing into the United States, marketing, supporting, providing product instruction and/or advertising certain of its products, including the Accused Fibre-to-Fibre Products, and Defendant knew that its actions were inducing end users to infringe the '147 Patent.

29. Further, upon information and belief, Defendant has been and now is indirectly infringing by way of contributing to the infringement by end users of the '147 Patent by selling,

offering to sell and/or importing into the United States components, including the Accused Fibre-to-Fibre Products, knowing the components to be especially made or especially adapted for use in the infringement of the '147 Patent. Such components are not a staple article or commodity of commerce suitable for substantial non-infringing uses.

30. Defendant has been on constructive and/or actual notice of the '147 Patent since at least as early as August 14, 2006, and Defendant has not ceased its infringing activities. The infringement of the '147 Patent by Defendant has been and continues to be willful and deliberate.

31. Crossroads has been irreparably harmed by Defendant's acts of infringement of the '147 Patent, and will continue to be harmed unless and until Defendant's acts of infringement are enjoined and restrained by order of this Court.

32. As a result of the acts of infringement of the '147 Patent by Defendant, Crossroads has suffered and will continue to suffer damages in an amount to be proven at trial.

DEMAND FOR JURY TRIAL

Crossroads hereby demands a trial by jury on all issues.

PRAYER FOR RELIEF

WHEREFORE, Crossroads requests this Court enter judgment as follows:

- A. That Defendant has infringed the '035 Patent;
- B. That such infringement of the '035 Patent by Defendant has been willful;
- C. That Defendant accounts for and pays to Crossroads all damages caused by the infringement of the '035 Patent;

- D. That Crossroads receive enhanced damages from Defendant in the form of treble damages, pursuant to 35 U.S.C. § 284 based on Defendant's willful infringement of the '035 Patent;
- E. That Crossroads be granted pre-judgment and post-judgment interest on the damages caused to it by reason of Defendant's infringement of the '035 Patent, including pre-judgment and post-judgment interest on any enhanced damages or attorneys' fees award;
- F. That Defendant has infringed the '041 Patent;
- G. That such infringement of the '041 Patent by Defendant has been willful;
- H. That Defendant accounts for and pays to Crossroads all damages caused by the infringement of the '041 Patent;
- I. That Crossroads receive enhanced damages from Defendant in the form of treble damages, pursuant to 35 U.S.C. § 284 based on Defendant's willful infringement of the '041 Patent;
- J. That Crossroads be granted pre-judgment and post-judgment interest on the damages caused to it by reason of Defendant's infringement of the '041 Patent, including pre-judgment and post-judgment interest on any enhanced damages or attorneys' fees award;
- K. That Defendant has infringed the '147 Patent;
- L. That such infringement of the '147 Patent by Defendant has been willful;
- M. That Defendant accounts for and pays to Crossroads all damages caused by the infringement of the '147 Patent;

TO: Mail Stop 8 Director of the U.S. Patent and Trademark Office P.O. Box 1450 Alexandria, VA 22313-1450	REPORT ON THE FILING OR DETERMINATION OF AN ACTION REGARDING A PATENT OR TRADEMARK
---------------------------------------------------------------------------------------------------------------------------------	----------------------------------------------------------------------------------------------------------------------------------------------------------

In Compliance with 35 U.S.C. § 290 and/or 15 U.S.C. § 1116 you are hereby advised that a court action has been filed in the U.S. District Court Western District of Texas, Austin Division on the following

Trademarks or Patents. (the patent action involves 35 U.S.C. § 292.):

DOCKET NO. 1:13-cv-1026 SS	DATE FILED 11/26/2013	U.S. DISTRICT COURT Western District of Texas, Austin Division
PLAINTIFF Crossroads Systems, Inc.		DEFENDANT Tandberg Data Corporation
PATENT OR TRADEMARK NO.	DATE OF PATENT OR TRADEMARK	HOLDER OF PATENT OR TRADEMARK
1 See attached		
2 6,425,035		
3 7,934,041		
4		
5		

In the above—entitled case, the following patent(s)/ trademark(s) have been included:

DATE INCLUDED	INCLUDED BY <input type="checkbox"/> Amendment <input type="checkbox"/> Answer <input type="checkbox"/> Cross Bill <input type="checkbox"/> Other Pleading	
PATENT OR TRADEMARK NO.	DATE OF PATENT OR TRADEMARK	HOLDER OF PATENT OR TRADEMARK
1		
2		
3		
4		
5		

In the above—entitled case, the following decision has been rendered or judgement issued:

DECISION/JUDGEMENT

CLERK William Putnicki	(BY) DEPUTY CLERK <i>Dianna Massie</i>	DATE 11/27/2013
---------------------------	-------------------------------------------	--------------------

Copy 1—Upon initiation of action, mail this copy to Director Copy 3—Upon termination of action, mail this copy to Director
 Copy 2—Upon filing document adding patent(s), mail this copy to Director Copy 4—Case file copy

IN THE UNITED STATES DISTRICT COURT
FOR THE WESTERN DISTRICT OF TEXAS
AUSTIN DIVISION

CROSSROADS SYSTEMS, INC.,	§	
	§	
Plaintiff,	§	
	§	CIVIL ACTION NO. 1:13-CV-1026
v.	§	
	§	JURY DEMANDED
TANDBERG DATA CORPORATION,	§	
	§	
Defendant.	§	

**PLAINTIFF CROSSROADS SYSTEMS, INC.’S
COMPLAINT FOR PATENT INFRINGEMENT**

THE PARTIES

1. Plaintiff Crossroads Systems, Inc. (“Crossroads”) is a corporation incorporated under the laws of the State of Delaware and has its principal place of business at 11000 North MoPac Expressway, Austin, Texas 78759.

2. Upon information and belief, Defendant Tandberg Data Corporation (“Defendant”) is a Delaware corporation with a principal place of business of 10225 Westmoor Drive, Suite 125, Westminster Colorado 80021.

JURISDICTION AND VENUE

3. This action arises under the laws of the United States, more specifically under 35 U.S.C. § 100, *et seq.* Subject matter jurisdiction is proper in this Court pursuant to 28 U.S.C. §§ 1331 and 1338.

4. Personal jurisdiction and venue are proper in this district under 28 U.S.C. §§ 1391 and 1400(b). Upon information and belief, Defendant has established minimum contacts with this forum such that the exercise of jurisdiction over Defendant would not offend traditional notions of fair play and substantial justice.

5. This Court has personal jurisdiction over Defendant. Upon information and belief, Defendant regularly conducts business in the State of Texas and in this judicial district and is subject to the jurisdiction of this Court. Upon information and belief, Defendant has been doing business in Texas and this judicial district by distributing, marketing, selling and/or offering for sale its products, including, but not limited to, products that practice the subject matter claimed in the Patents-In-Suit, and/or regularly doing or soliciting business and/or engaging in other persistent courses of conduct in and/or directed to Texas and this judicial district.

COUNT 1: INFRINGEMENT OF U.S. PATENT NO. 6,425,035

6. Crossroads incorporates by reference the allegations set forth in the preceding paragraphs.

7. On July 23, 2002, United States Patent No. 6,425,035 (the "'035 Patent") was duly and legally issued. A true and correct copy of the '035 Patent is attached hereto as Exhibit A. Crossroads is the assignee and the owner of all right, title, and interest in and to the '035 Patent. The '035 Patent is entitled to a presumption of validity.

8. On information and belief, Defendant has directly infringed the '035 Patent. On information and belief, Defendant continues to directly infringe the '035 Patent.

9. Specifically, on information and belief, Defendant has directly infringed the '035 Patent by making, using, offering for sale, selling and/or importing into the United States certain of its products including at least the following: the BizNAS family of devices (including the D400, D408, R400, and R408), the DPS1000 Series Virtual Tape Libraries (including the DPS1100 and DPS1200) and the DPS2000 Series Network-Attached Data Protection Solution (including the DPS2040, DPS2140, and DPS2142).

10. Further, on information and belief, Defendant has been and now is indirectly infringing by way of inducing infringement of the '035 Patent with knowledge of the '035 Patent by making, offering for sale, selling, importing into the United States, marketing, supporting, providing product instruction and/or advertising certain of its products, including the BizNAS family of devices (including the D400, D408, R400, and R408), the DPS1000 Series Virtual Tape Libraries (including the DPS1100 and DPS1200); and the DPS2000 Series Network-Attached Data Protection Solution (including the DPS2040, DPS2140, and DPS2142), and Defendant knew that its actions were inducing end users to infringe the '035 Patent.

11. Further, on information and belief, Defendant has been and now is indirectly infringing by way of contributing to the infringement by end users of the '035 Patent by selling, offering to sell and/or importing into the United States components, including the BizNAS family of devices (including the D400, D408, R400, and R408), the DPS1000 Series Virtual Tape Libraries (including the DPS1100 and DPS1200) and the DPS2000 Series Network-Attached Data Protection Solution (including the DPS2040, DPS2140, and DPS2142), knowing the components to be especially made or especially adapted for use in the infringement of the '035 Patent. Such components are not a staple article or commodity of commerce suitable for substantial non-infringing uses.

12. Defendant has been on constructive and/or actual notice of the '035 Patent since at least as early as August 2011, and Defendant has not ceased its infringing activities. The infringement of the '035 Patent by Defendant has been and continues to be willful and deliberate.

13. Crossroads has been irreparably harmed by Defendant's acts of infringement of the '035 Patent, and will continue to be harmed unless and until Defendant's acts of infringement are enjoined and restrained by order of this Court.

14. As a result of the acts of infringement of the '035 Patent by Defendant, Crossroads has suffered and will continue to suffer damages in an amount to be proven at trial.

COUNT 2: INFRINGEMENT OF U.S. PATENT NO. 7,934,041

15. Crossroads incorporates by reference the allegations set forth in the preceding paragraphs.

16. On April 26, 2011, United States Patent No. 7,934,041 (the "'041 Patent") was duly and legally issued. A true and correct copy of the '041 Patent is attached hereto as Exhibit B. Crossroads is the assignee and the owner of all right, title, and interest in and to the '041 Patent. The '041 Patent is entitled to a presumption of validity.

17. On information and belief, Defendant has directly infringed the '041 Patent. On information and belief, Defendant continues to directly infringe the '041 Patent.

18. Specifically, on information and belief, Defendant has directly infringed the '041 Patent by making, using, offering for sale, selling and/or importing into the United States certain of its products including at least the following: the BizNAS family of devices (including the D400, D408, R400, and R408), the DPS1000 Series Virtual Tape Libraries (including the DPS1100 and DPS1200) and the DPS2000 Series Network-Attached Data Protection Solution (including the DPS2040, DPS2140, and DPS2142).

19. Further, upon information and belief, Defendant has been and now is indirectly infringing by way of inducing infringement of the '041 Patent with knowledge of the '041 Patent by making, offering for sale, selling, importing into the United States, marketing, supporting, providing product instruction and/or advertising certain of its products, including the BizNAS family of devices (including the D400, D408, R400, and R408), the DPS1000 Series Virtual Tape Libraries (including the DPS1100 and DPS1200) and the DPS2000 Series Network-

Attached Data Protection Solution (including the DPS2040, DPS2140, and DPS2142) and Defendant knew that its actions were inducing end users to infringe the '041 Patent.

20. Further, upon information and belief, Defendant has been and now is indirectly infringing by way of contributing to the infringement by end users of the '041 Patent by selling, offering to sell and/or importing into the United States components, including the BizNAS family of devices (including the D400, D408, R400, and R408), the DPS1000 Series Virtual Tape Libraries (including the DPS1100 and DPS1200), the DPS2000 Series Network-Attached Data Protection Solution (including the DPS2040, DPS2140, and DPS2142), knowing the components to be especially made or especially adapted for use in the infringement of the '041 Patent. Such components are not a staple article or commodity of commerce suitable for substantial non-infringing uses.

21. Defendant has been on constructive and/or actual notice of the '041 Patent since at least as early as August 2011 and Defendant has not ceased its infringing activities. The infringement of the '041 Patent by Defendant has been and continues to be willful and deliberate.

22. Crossroads has been irreparably harmed by Defendant's acts of infringement of the '041 Patent, and will continue to be harmed unless and until Defendant's acts of infringement are enjoined and restrained by order of this Court.

23. As a result of the acts of infringement of the '041 Patent by Defendant, Crossroads has suffered and will continue to suffer damages in an amount to be proven at trial.

PRAYER FOR RELIEF

WHEREFORE, Crossroads requests this Court enter judgment as follows:

- A. That Defendant has infringed the '035 Patent;
- B. That such infringement of the '035 Patent by Defendant has been willful;

- C. That Defendant accounts for and pays to Crossroads all damages caused by the infringement of the '035 Patent;
- D. That Crossroads receive enhanced damages from Defendant in the form of treble damages, pursuant to 35 U.S.C. § 284 based on Defendant's willful infringement of the '035 Patent;
- E. That Crossroads be granted pre-judgment and post-judgment interest on the damages caused to it by reason of Defendant's infringement of the '035 Patent, including pre-judgment and post-judgment interest on any enhanced damages or attorneys' fees award;
- F. That Defendant has infringed the '041 Patent;
- G. That such infringement of the '041 Patent by Defendant has been willful;
- H. That Defendant accounts for and pays to Crossroads all damages caused by the infringement of the '041 Patent;
- I. That Crossroads receive enhanced damages from Defendant in the form of treble damages, pursuant to 35 U.S.C. § 284 based on Defendant's willful infringement of the '041 Patent;
- J. That Crossroads be granted pre-judgment and post-judgment interest on the damages caused to it by reason of Defendant's infringement of the '041 Patent, including pre-judgment and post-judgment interest on any enhanced damages or attorneys' fees award;
- K. That Defendant pay Crossroads all of Crossroads' reasonable attorneys' fees and expenses;
- L. That costs be awarded to Crossroads;

- M. That Defendant, its agents, employees, representatives, successors and assigns, and those acting in privity or in concert with it, be preliminary and permanently enjoined from further infringement of the '035 Patent;
- N. That Defendant, its agents, employees, representatives, successors and assigns, and those acting in privity or in concert with it, be preliminary and permanently enjoined from further infringement of the '041 Patent;
- O. That this is an exceptional case under 35 U.S.C. § 285; and
- P. That Crossroads be granted such other and further relief as the Court may deem just and proper under the circumstances.

DEMAND FOR JURY TRIAL

Crossroads hereby demands a trial by jury on all issues.

Dated: November 26, 2013

Respectfully submitted,

By: /s/ Steven Sprinkle
Steven Sprinkle
Texas Bar No. 00794962
Elizabeth J. Brown Fore
Texas Bar No. 24001795
Sprinkle IP Law Group, PC
1301 W. 25th Street, Suite 408
Austin, Texas 78705
Tel: 512-637-9220
Fax: 512-371-9088
ssprinkle@sprinklelaw.com
ebrownfore@sprinklelaw.com

Susan K. Knoll
Texas Bar No. 11616900
Russell T. Wong
Texas Bar No. 21884235
James H. Hall
Texas Bar No. 24041040
WONG, CABELLO, LUTSCH,
RUTHERFORD & BRUCCULERI, L.L.P.
20333 SH 249, Suite 600
Houston, TX 77070
Tel: 832-446-2400
Fax: 832-446-2424
sknoll@counselip.com
rwong@counselip.com
jhall@counselip.com

*ATTORNEYS FOR PLAINTIFF
CROSSROADS SYSTEMS, INC.*

TO: Mail Stop 8 Director of the U.S. Patent and Trademark Office P.O. Box 1450 Alexandria, VA 22313-1450	REPORT ON THE FILING OR DETERMINATION OF AN ACTION REGARDING A PATENT OR TRADEMARK
---------------------------------------------------------------------------------------------------------------------------------	----------------------------------------------------------------------------------------------------------------------------------------------------------

In Compliance with 35 U.S.C. § 290 and/or 15 U.S.C. § 1116 you are hereby advised that a court action has been filed in the U.S. District Court Western District of Texas, Austin Division on the following
 Trademarks or Patents. (the patent action involves 35 U.S.C. § 292.);

DOCKET NO. 1:13-cv-1025-SS	DATE FILED 11/26/2013	U.S. DISTRICT COURT Western District of Texas, Austin Division
PLAINTIFF Crossroads Systems, Inc.		DEFENDANT Huawei Technologies Co. Ltd., Huawei Enterprise USA Inc. and Huawei Technologies USA Inc.
PATENT OR TRADEMARK NO.	DATE OF PATENT OR TRADEMARK	HOLDER OF PATENT OR TRADEMARK
1 see attached		
2 6,425,035		
3 7,934,041		
4 7,051,147		
5		

In the above—entitled case, the following patent(s)/ trademark(s) have been included:

DATE INCLUDED	INCLUDED BY <input type="checkbox"/> Amendment <input type="checkbox"/> Answer <input type="checkbox"/> Cross Bill <input type="checkbox"/> Other Pleading		
PATENT OR TRADEMARK NO.	DATE OF PATENT OR TRADEMARK	HOLDER OF PATENT OR TRADEMARK	
1			
2			
3			
4			
5			

In the above—entitled case, the following decision has been rendered or judgement issued:

DECISION/JUDGEMENT

CLERK William G. Putnicki	(BY) DEPUTY CLERK <i>Olga Schwede</i>	DATE 11/27/2013
------------------------------	------------------------------------------	--------------------

Copy 1—Upon initiation of action, mail this copy to Director Copy 3—Upon termination of action, mail this copy to Director
 Copy 2—Upon filing document adding patent(s), mail this copy to Director Copy 4—Case file copy

- H. That Defendants account for and pay to Crossroads all damages caused by the infringement of the '041 Patent;
- I. That Crossroads receive enhanced damages from Defendants in the form of treble damages, pursuant to 35 U.S.C. § 284 based on Defendants' willful infringement of the '041 Patent;
- J. That Crossroads be granted pre-judgment and post-judgment interest on the damages caused to it by reason of Defendants' infringement of the '041 Patent, including pre-judgment and post-judgment interest on any enhanced damages or attorneys' fees award;
- K. That Defendants have infringed the '147 Patent;
- L. That such infringement of the '147 Patent by Defendants has been willful;
- M. That Defendants account for and pay to Crossroads all damages caused by the infringement of the '147 Patent;
- N. That Crossroads receive enhanced damages from Defendants in the form of treble damages, pursuant to 35 U.S.C. § 284 based on Defendants' willful infringement of the '147 Patent;
- O. That Crossroads be granted pre-judgment and post-judgment interest on the damages caused to it by reason of Defendants' infringement of the '147 Patent, including pre-judgment and post-judgment interest on any enhanced damages or attorneys' fees award;
- P. That Defendants pay Crossroads all of Crossroads' reasonable attorneys' fees and expenses;
- Q. That costs be awarded to Crossroads;

- R. That Defendants, Defendants' agents, employees, representatives, successors and assigns, and those acting in privity or in concert with Defendants, be preliminary and permanently enjoined from further infringement of the '035 Patent;
- S. That Defendant, Defendants' agents, employees, representatives, successors and assigns, and those acting in privity or in concert with Defendants, be preliminary and permanently enjoined from further infringement of the '041 Patent;
- T. That Defendants, Defendants' agents, employees, representatives, successors and assigns, and those acting in privity or in concert with Defendants, be preliminary and permanently enjoined from further infringement of the '147 Patent;
- U. That this is an exceptional case under 35 U.S.C. § 285; and
- V. That Crossroads be granted such other and further relief as the Court may deem just and proper under the circumstances.

DEMAND FOR JURY TRIAL

Crossroads hereby demands a trial by jury on all issues.

Dated: November 26, 2013

Respectfully submitted,

By: /s/ Steven Sprinkle

Steven Sprinkle
Texas Bar No. 00794962
Elizabeth J. Brown Fore
Texas Bar No. 24001795
Sprinkle IP Law Group, PC
1301 W. 25th Street, Suite 408
Austin, Texas 78705
Tel: 512-637-9220
Fax: 512-371-9088
ssprinkle@sprinklelaw.com
ebrownfore@sprinklelaw.com

Susan K. Knoll
Texas Bar No. 11616900
Russell T. Wong
Texas Bar No. 21884235
James H. Hall
Texas Bar No. 24041040
WONG, CABELLO, LUTSCH,
RUTHERFORD & BRUCCULERI, L.L.P.
20333 SH 249, Suite 600
Houston, TX 77070
Tel: 832-446-2400
Fax: 832-446-2424
sknoll@counselip.com
rwong@counselip.com
jhall@counselip.com

*ATTORNEYS FOR PLAINTIFF
CROSSROADS SYSTEMS, INC.*

IN THE UNITED STATES DISTRICT COURT
FOR THE WESTERN DISTRICT OF TEXAS
AUSTIN DIVISION

CROSSROADS SYSTEMS, INC.,

Plaintiff,

v.

HUAWEI TECHNOLOGIES CO. LTD.,
HUAWEI ENTERPRISE USA INC.
HUAWEI TECHNOLOGIES USA INC.

Defendants.

§
§
§
§
§
§
§
§
§
§
§
§

CIVIL ACTION NO. 1:13-CV-1025

JURY DEMANDED

**PLAINTIFF CROSSROADS SYSTEMS, INC.’S
COMPLAINT FOR PATENT INFRINGEMENT**

THE PARTIES

1. Plaintiff Crossroads Systems, Inc. (“Crossroads”) is a corporation incorporated under the laws of the State of Delaware and has its principal place of business at 11000 North MoPac Expressway, Austin, Texas 78759.

2. Upon information and belief, Defendant Huawei Technologies Co. Ltd. (“Huawei China”) is a corporation organized and existing under the laws of the People’s Republic of China with its principal place of business in Huawei Industrial Base, Bantian, Longgang, Shenzhen, Guangdong, P.R. China, 518129.

3. Upon information and belief, Defendant Huawei Enterprise USA Inc. (“Huawei Enterprise”) is a California Corporation with its principal office at 3965 Freedom Circle, 11th Floor, Santa Clara, CA 95054.

4. Upon information and belief, Defendant Huawei Technologies USA Inc. is a Texas corporation with its principal office at 5700 Tennyson Parkway, Suite 500, Plano, TX 75024.

JURISDICTION AND VENUE

5. This action arises under the laws of the United States, more specifically under 35 U.S.C. § 100, *et seq.* Subject matter jurisdiction is proper in this Court pursuant to 28 U.S.C. §§ 1331 and 1338.

6. Personal jurisdiction and venue are proper in this district under 28 U.S.C. §§ 1391 and 1400(b). Upon information and belief, Defendants Huawei China, Huawei Enterprise and Huawei Technologies USA Inc. established minimum contacts with this forum such that the exercise of jurisdiction over Defendants would not offend traditional notions of fair play and substantial justice. Upon information and belief, Defendants regularly conduct business in the State of Texas and in this judicial district and are subject to the jurisdiction of this Court. Upon information and belief, Defendants have been doing business in Texas and this judicial district by distributing, marketing, selling and/or offering for sale its products, including, but not limited to, products that practice the subject matter claimed in the Patents-In-Suit, and/or regularly doing or soliciting business and/or engaging in other persistent courses of conduct in and/or directed to Texas and this judicial district.

COUNT 1: INFRINGEMENT OF U.S. PATENT NO. 6,425,035

7. Crossroads incorporates by reference the allegations set forth in the preceding paragraphs.

8. On July 23, 2002, United States Patent No. 6,425,035 (the "'035 Patent'") was duly and legally issued. A true and correct copy of the '035 Patent is attached hereto as Exhibit A. Crossroads is the assignee and the owner of all right, title, and interest in and to the '035 Patent. The '035 Patent is entitled to a presumption of validity.

9. On information and belief, Defendants have directly infringed the '035 Patent. On information and belief, Defendant continues to directly infringe the '035 Patent.

10. Specifically, on information and belief, Defendants have directly infringed the '035 Patent by making, using, offering for sale, selling and/or importing into the United States certain of products including at least the following: OceanStor S2200T Storage System, OceanStor S6800T Storage System, OceanStor T Series Unified Storage Systems (including the OceanStor S2600T, OceanStor S5500T, OceanStor S5600T, OceanStor S5800T), OceanStor HVS85T Storage Systems, OceanStor HVS88T Storage Systems, OceanStor VIS6600T Storage Systems, OceanStor Dorado 2100 G2 Storage Systems, and OceanStor Dorado 5100 Storage Systems.

11. Further, on information and belief, Defendants have been and now are indirectly infringing by way of inducing infringement of the '035 Patent with knowledge of the '035 Patent by making, offering for sale, selling, importing into the United States, marketing, supporting, providing product instruction and/or advertising certain products, including the OceanStor S2200T Storage System, OceanStor S6800T Storage System, OceanStor T Series Unified Storage Systems (including the OceanStor S2600T, OceanStor S5500T, OceanStor S5600T, OceanStor S5800T), OceanStor HVS85T Storage Systems, OceanStor HVS88T Storage Systems, OceanStor VIS6600T Storage Systems, OceanStor Dorado 2100 G2 Storage Systems, and OceanStor Dorado 5100 Storage Systems, and Defendants knew that these actions were inducing end users to infringe the '035 Patent.

12. Further, on information and belief, Defendants have been and now are indirectly infringing by way of contributing to the infringement by end users of the '035 Patent by selling, offering to sell and/or importing into the United States components, including the OceanStor

S2200T Storage System, OceanStor S6800T Storage System, OceanStor T Series Unified Storage Systems (including the OceanStor S2600T, OceanStor S5500T, OceanStor S5600T, OceanStor S5800T) OceanStor HVS85T Storage Systems, OceanStor HVS88T Storage Systems, OceanStor VIS6600T Storage Systems, OceanStor Dorado 2100 G2 Storage Systems, and OceanStor Dorado 5100 Storage Systems, knowing the components to be especially made or especially adapted for use in the infringement of the '035 Patent. Such components are not a staple article or commodity of commerce suitable for substantial non-infringing uses.

13. Defendants have been on constructive and/or actual notice of the '035 Patent since at least as early as February 2012, and Defendants have not ceased their infringing activities. The infringement of the '035 Patent by Defendants has been and continues to be willful and deliberate.

14. Crossroads has been irreparably harmed by Defendants' acts of infringement of the '035 Patent, and will continue to be harmed unless and until Defendants' acts of infringement are enjoined and restrained by order of this Court.

15. As a result of the acts of infringement of the '035 Patent by Defendants, Crossroads has suffered and will continue to suffer damages in an amount to be proven at trial.

COUNT 2: INFRINGEMENT OF U.S. PATENT NO. 7,934,041

16. Crossroads incorporates by reference the allegations set forth in the preceding paragraphs.

17. On April 26, 2011, United States Patent No. 7,934,041 (the "'041 Patent") was duly and legally issued. A true and correct copy of the '041 Patent is attached hereto as Exhibit B. Crossroads is the assignee and the owner of all right, title, and interest in and to the '041 Patent. The '041 Patent is entitled to a presumption of validity.

18. On information and belief, Defendants have directly infringed the '041 Patent. On information and belief, Defendants continue to directly infringe the '041 Patent.

19. Specifically, on information and belief, Defendants have directly infringed the '041 Patent by making, using, offering for sale, selling and/or importing into the United States certain products including at least the following: OceanStor S2200T Storage System, OceanStor S6800T Storage System, OceanStor T Series Unified Storage Systems (including the OceanStor S2600T, OceanStor S5500T, OceanStor S5600T, OceanStor S5800T) OceanStor HVS85T Storage Systems, OceanStor HVS88T Storage Systems, OceanStor VIS6600T Storage Systems, OceanStor Dorado 2100 G2 Storage Systems, and OceanStor Dorado 5100 Storage Systems.

20. Further, upon information and belief, Defendants have been and now are indirectly infringing by way of inducing infringement of the '041 Patent with knowledge of the '041 Patent by making, offering for sale, selling, importing into the United States, marketing, supporting, providing product instruction and/or advertising certain products, including the OceanStor S2200T Storage System, OceanStor S6800T Storage System, OceanStor T Series Unified Storage Systems (including the OceanStor S2600T, OceanStor S5500T, OceanStor S5600T, OceanStor S5800T), OceanStor HVS85T Storage Systems, OceanStor HVS88T Storage Systems, OceanStor VIS6600T Storage Systems, OceanStor Dorado 2100 G2 Storage Systems, and OceanStor Dorado 5100 Storage Systems, and Defendant knew that these actions were inducing end users to infringe the '041 Patent.

21. Further, upon information and belief, Defendants have been and now are indirectly infringing by way of contributing to the infringement by end users of the '041 Patent by selling, offering to sell and/or importing into the United States components, OceanStor S2200T Storage System, OceanStor S6800T Storage System, OceanStor T Series Unified

Storage Systems (including the OceanStor S2600T, OceanStor S5500T, OceanStor S5600T, OceanStor S5800T), OceanStor HVS85T Storage Systems, OceanStor HVS88T Storage Systems, OceanStor VIS6600T Storage Systems, OceanStor Dorado 2100 G2 Storage Systems, and OceanStor Dorado 5100 Storage Systems, knowing the components to be especially made or especially adapted for use in the infringement of the '041 Patent. Such components are not a staple article or commodity of commerce suitable for substantial non-infringing uses.

22. Defendants have been on constructive and/or actual notice of the '041 Patent since at least as early as February 2012, and Defendants have not ceased the infringing activities. The infringement of the '041 Patent by Defendants has been and continues to be willful and deliberate.

23. Crossroads has been irreparably harmed by Defendants' acts of infringement of the '041 Patent, and will continue to be harmed unless and until Defendants' acts of infringement are enjoined and restrained by order of this Court.

24. As a result of the acts of infringement of the '041 Patent by Defendants, Crossroads has suffered and will continue to suffer damages in an amount to be proven at trial.

COUNT 3: INFRINGEMENT OF U.S. PATENT NO. 7,051,147

25. Crossroads incorporates by reference the allegations set forth in the preceding paragraphs.

26. On May 23, 2006, United States Patent No. 7,051,147 (the "'147 Patent'") was duly and legally issued. A true and correct copy of the '147 Patent is attached hereto as Exhibit C. Crossroads is the assignee and the owner of all right, title, and interest in and to the '147 Patent. The '147 Patent is entitled to a presumption of validity.

27. On information and belief, Defendants have directly infringed the '147 Patent. On information and belief, Defendants continue to directly infringe the '147 Patent.

28. Specifically, on information and belief, Defendants have directly infringed the '147 Patent by making, using, offering for sale, selling and/or importing into the United States certain products including at least the following: OceanStor S5600T Storage Systems, OceanStor S5800T Storage Systems, OceanStor S6800T Storage Systems, OceanStor VIS6600T Storage Systems.

29. Further, on information and belief, Defendants have been and now are indirectly infringing by way of inducing infringement of the '147 Patent with knowledge of the '147 Patent by making, offering for sale, selling, importing into the United States, marketing, supporting, providing product instruction and/or advertising certain products, including the OceanStor S5600T Storage Systems, OceanStor S5800T Storage Systems, OceanStor S6800T Storage Systems, OceanStor VIS6600T Storage Systems, and Defendants knew that these actions were inducing end users to infringe the '147 Patent.

30. Further, on information and belief, Defendants have been and now are indirectly infringing by way of contributing to the infringement by end users of the '147 Patent by selling, offering to sell and/or importing into the United States components, including OceanStor S5600T Storage Systems, OceanStor S5800T Storage Systems, OceanStor S6800T Storage Systems, OceanStor VIS6600T Storage Systems, knowing the components to be especially made or especially adapted for use in the infringement of the '147 Patent. Such components are not a staple article or commodity of commerce suitable for substantial non-infringing uses.

31. Defendants have been on constructive and/or actual notice of the '147 Patent since at least as early as February 2012, and Defendants have not ceased the infringing activities.

The infringement of the '147 Patent by Defendants has been and continues to be willful and deliberate.

32. Crossroads has been irreparably harmed by Defendants' acts of infringement of the '147 Patent, and will continue to be harmed unless and until Defendants' acts of infringement are enjoined and restrained by order of this Court.

33. As a result of the acts of infringement of the '147 Patent by Defendants, Crossroads has suffered and will continue to suffer damages in an amount to be proven at trial.

PRAYER FOR RELIEF

WHEREFORE, Crossroads requests this Court enter judgment as follows:

- A. That Defendants have infringed the '035 Patent;
- B. That such infringement of the '035 Patent by Defendants has been willful;
- C. That Defendants account for and pays to Crossroads all damages caused by the infringement of the '035 Patent;
- D. That Crossroads receive enhanced damages from Defendants in the form of treble damages, pursuant to 35 U.S.C. § 284 based on Defendants' willful infringement of the '035 Patent;
- E. That Crossroads be granted pre-judgment and post-judgment interest on the damages caused to it by reason of Defendants' infringement of the '035 Patent, including pre-judgment and post-judgment interest on any enhanced damages or attorneys' fees award;
- F. That Defendants have infringed the '041 Patent;
- G. That such infringement of the '041 Patent by Defendants has been willful;

TO: Mail Stop 8 Director of the U.S. Patent and Trademark Office P.O. Box 1450 Alexandria, VA 22313-1450	REPORT ON THE FILING OR DETERMINATION OF AN ACTION REGARDING A PATENT OR TRADEMARK
---------------------------------------------------------------------------------------------------------------------------------	----------------------------------------------------------------------------------------------------------------------------------------------------------

In Compliance with 35 U.S.C. § 290 and/or 15 U.S.C. § 1116 you are hereby advised that a court action has been filed in the U.S. District Court Western District of Texas, Austin Division on the following
 Trademarks or Patents. (the patent action involves 35 U.S.C. § 292.);

DOCKET NO. 1:13-cv-1023-SS	DATE FILED 11/26/2013	U.S. DISTRICT COURT Western District of Texas, Austin Division
PLAINTIFF Crossroads Systems, Inc.		DEFENDANT Dell Inc.
PATENT OR TRADEMARK NO.	DATE OF PATENT OR TRADEMARK	HOLDER OF PATENT OR TRADEMARK
1 see attached		
2 6,425,035		
3 7,934,041		
4		
5		

In the above—entitled case, the following patent(s)/ trademark(s) have been included:

DATE INCLUDED	INCLUDED BY <input type="checkbox"/> Amendment <input type="checkbox"/> Answer <input type="checkbox"/> Cross Bill <input type="checkbox"/> Other Pleading	
PATENT OR TRADEMARK NO.	DATE OF PATENT OR TRADEMARK	HOLDER OF PATENT OR TRADEMARK
1		
2		
3		
4		
5		

In the above—entitled case, the following decision has been rendered or judgement issued:

DECISION/JUDGEMENT

CLERK William G. Putnicki	(BY) DEPUTY CLERK <i>W. Schroeder</i>	DATE 11/27/2013
------------------------------	------------------------------------------	--------------------

Copy 1—Upon initiation of action, mail this copy to Director Copy 3—Upon termination of action, mail this copy to Director
 Copy 2—Upon filing document adding patent(s), mail this copy to Director Copy 4—Case file copy

IN THE UNITED STATES DISTRICT COURT
FOR THE WESTERN DISTRICT OF TEXAS
AUSTIN DIVISION

CROSSROADS SYSTEMS, INC.,

Plaintiff,

v.

DELL INC.,

Defendant.

§
§
§
§
§
§
§
§
§
§

CIVIL ACTION NO. 1:13-CV-1023

JURY DEMANDED

**PLAINTIFF CROSSROADS SYSTEMS, INC.’S
COMPLAINT FOR PATENT INFRINGEMENT**

THE PARTIES

1. Plaintiff Crossroads Systems, Inc. (“Crossroads”) is a corporation incorporated under the laws of the State of Delaware and has its principal place of business at 11000 North MoPac Expressway, Austin, Texas 78759.

2. Upon information and belief, Defendant Dell Inc. (“Defendant”) is a Delaware corporation with its principal place of business at 1 Dell Way, Round Rock, Texas 78682.

JURISDICTION AND VENUE

3. This action arises under the laws of the United States, more specifically under 35 U.S.C. § 100, *et seq.* Subject matter jurisdiction is proper in this Court pursuant to 28 U.S.C. §§ 1331 and 1338.

4. Personal jurisdiction and venue are proper in this district under 28 U.S.C. §§ 1391 and 1400(b). Defendant has established minimum contacts with this forum such that the exercise of jurisdiction over Defendant would not offend traditional notions of fair play and substantial justice. Defendant has its corporate headquarters and regularly conducts business in the State of Texas and in this judicial district and is subject to the jurisdiction of this Court. Defendant does

business in Texas and this judicial district by distributing, marketing, selling and/or offering for sale its products, including, but not limited to, products that practice the subject matter claimed in the Patents-In-Suit, and/or regularly doing or soliciting business and/or engaging in other persistent courses of conduct in and/or directed to Texas and this judicial district.

COUNT 1: INFRINGEMENT OF U.S. PATENT NO. 6,425,035

5. Crossroads incorporates by reference the allegations set forth in the preceding paragraphs.

6. On July 23, 2002, United States Patent No. 6,425,035 (the "'035 Patent") was duly and legally issued. A true and correct copy of the '035 Patent is attached hereto as Exhibit A. Crossroads is the assignee and the owner of all right, title, and interest in and to the '035 Patent. The '035 Patent is entitled to a presumption of validity.

7. On information and belief, Defendant has directly infringed the '035 Patent. On information and belief, Defendant continues to directly infringe the '035 Patent.

8. Specifically, on information and belief, Defendant has directly infringed the '035 Patent by making, using, offering for sale, selling and/or importing into the United States certain of its products including at least the following: Dell PowerVault MD3200i series (including the MD3200i, MD3220i, and MD3260i); Dell PowerVault MD3600i series (including the MD3600i, MD3620i, MD3660i) and Dell PowerVault MD3600f series (including the MD3600f, MD3620f, MD3660f).

9. Further, on information and belief, Defendant has been and now is indirectly infringing by way of inducing infringement of the '035 Patent with knowledge of the '035 Patent by making, offering for sale, selling, importing into the United States, marketing, supporting, providing product instruction and/or advertising certain of its products, including the Dell

PowerVault MD3200i series (including the MD3200i, MD3220i, and MD3260i); Dell PowerVault MD3600i series (including the MD3600i, MD3620i, MD3660i) and Dell PowerVault MD3600f series (including the MD3600f, MD3620f, MD3660f), and Defendant knew that its actions were inducing end users to infringe the '035 Patent.

10. Further, on information and belief, Defendant has been and now is indirectly infringing by way of contributing to the infringement by end users of the '035 Patent by selling, offering to sell and/or importing into the United States components, including the Dell PowerVault MD3200i series (including the MD3200i, MD3220i, and MD3260i); Dell PowerVault MD3600i series (including the MD3600i, MD3620i, MD3660i) and Dell PowerVault MD3600f series (including the MD3600f, MD3620f, MD3660f), knowing the components to be especially made or especially adapted for use in the infringement of the '035 Patent. Such components are not a staple article or commodity of commerce suitable for substantial non-infringing uses.

11. Defendant has been on constructive and/or actual notice of the '035 Patent since at least as early as November 2009, and Defendant has not ceased its infringing activities. The infringement of the '035 Patent by Defendant has been and continues to be willful and deliberate.

12. Crossroads has been irreparably harmed by Defendant's acts of infringement of the '035 Patent, and will continue to be harmed unless and until Defendant's acts of infringement are enjoined and restrained by order of this Court.

13. As a result of the acts of infringement of the '035 Patent by Defendant, Crossroads has suffered and will continue to suffer damages in an amount to be proven at trial.

COUNT 2: INFRINGEMENT OF U.S. PATENT NO. 7,934,041

14. Crossroads incorporates by reference the allegations set forth in the preceding paragraphs.

15. On April 26, 2011, United States Patent No. 7,934,041 (the "'041 Patent") was duly and legally issued. A true and correct copy of the '041 Patent is attached hereto as Exhibit B. Crossroads is the assignee and the owner of all right, title, and interest in and to the '041 Patent. The '041 Patent is entitled to a presumption of validity.

16. On information and belief, Defendant has directly infringed the '041 Patent. On information and belief, Defendant continues to directly infringe the '041 Patent.

17. Specifically, on information and belief, Defendant has directly infringed the '041 Patent by making, using, offering for sale, selling and/or importing into the United States certain of its products including at least the following: Dell PowerVault MD3200i series (including the MD3200i, MD3220i, and MD3260i); Dell PowerVault MD3600i series (including the MD3600i, MD3620i, MD3660i) and Dell PowerVault MD3600f series (including the MD3600f, MD3620f, MD3660f).

18. Further, upon information and belief, Defendant has been and now is indirectly infringing by way of inducing infringement of the '041 Patent with knowledge of the '041 Patent by making, offering for sale, selling, importing into the United States, marketing, supporting, providing product instruction and/or advertising certain of its products, including the Dell PowerVault MD3200i series (including the MD3200i, MD3220i, and MD3260i); Dell PowerVault MD3600i series (including the MD3600i, MD3620i, MD3660i) and Dell PowerVault MD3600f series (including MD3600f, MD3620f, MD3660f), and Defendant knew that its actions were inducing end users to infringe the '041 Patent.

19. Further, upon information and belief, Defendant has been and now is indirectly infringing by way of contributing to the infringement by end users of the '041 Patent by selling, offering to sell and/or importing into the United States components, including the Dell PowerVault MD3200i series (including the MD3200i, MD3220i, and MD3260i); Dell PowerVault MD3600i series (including the MD3600i, MD3620i, MD3660i) and Dell PowerVault MD3600f series (including the MD3600f, MD3620f, MD3660f), knowing the components to be especially made or especially adapted for use in the infringement of the '041 Patent. Such components are not a staple article or commodity of commerce suitable for substantial non-infringing uses.

20. Defendant has been on constructive and/or actual notice of the '041 Patent since at least as early as May 2011 and Defendant has not ceased its infringing activities. The infringement of the '041 Patent by Defendant has been and continues to be willful and deliberate.

21. Crossroads has been irreparably harmed by Defendant's acts of infringement of the '041 Patent, and will continue to be harmed unless and until Defendant's acts of infringement are enjoined and restrained by order of this Court.

22. As a result of the acts of infringement of the '041 Patent by Defendant, Crossroads has suffered and will continue to suffer damages in an amount to be proven at trial.

PRAYER FOR RELIEF

WHEREFORE, Crossroads requests this Court enter judgment as follows:

- A. That Defendant has infringed the '035 Patent;
- B. That such infringement of the '035 Patent by Defendant has been willful;
- C. That Defendant accounts for and pays to Crossroads all damages caused by the infringement of the '035 Patent;

- D. That Crossroads receive enhanced damages from Defendant in the form of treble damages, pursuant to 35 U.S.C. § 284 based on Defendant's willful infringement of the '035 Patent;
- E. That Crossroads be granted pre-judgment and post-judgment interest on the damages caused to it by reason of Defendant's infringement of the '035 Patent, including pre-judgment and post-judgment interest on any enhanced damages or attorneys' fees award;
- F. That Defendant has infringed the '041 Patent;
- G. That such infringement of the '041 Patent by Defendant has been willful;
- H. That Defendant accounts for and pays to Crossroads all damages caused by the infringement of the '041 Patent;
- I. That Crossroads receive enhanced damages from Defendant in the form of treble damages, pursuant to 35 U.S.C. § 284 based on Defendant's willful infringement of the '041 Patent;
- J. That Crossroads be granted pre-judgment and post-judgment interest on the damages caused to it by reason of Defendant's infringement of the '041 Patent, including pre-judgment and post-judgment interest on any enhanced damages or attorneys' fees award;
- K. That Defendant pay Crossroads all of Crossroads' reasonable attorneys' fees and expenses;
- L. That costs be awarded to Crossroads;

- M. That Defendant, its agents, employees, representatives, successors and assigns, and those acting in privity or in concert with it, be preliminary and permanently enjoined from further infringement of the '035 Patent;
- N. That Defendant, its agents, employees, representatives, successors and assigns, and those acting in privity or in concert with it, be preliminary and permanently enjoined from further infringement of the '041 Patent;
- O. That this is an exceptional case under 35 U.S.C. § 285; and
- P. That Crossroads be granted such other and further relief as the Court may deem just and proper under the circumstances.

DEMAND FOR JURY TRIAL

Crossroads hereby demands a trial by jury on all issues.

Dated: November 26, 2013

Respectfully submitted,

By: /s/ Steven Sprinkle
Steven Sprinkle
Texas Bar No. 00794962
Elizabeth J. Brown Fore
Texas Bar No. 24001795
Sprinkle IP Law Group, PC
1301 W. 25th Street, Suite 408
Austin, Texas 78705
Tel: 512-637-9220
Fax: 512-371-9088
ssprinkle@sprinklelaw.com
ebrownfore@sprinklelaw.com

Susan K. Knoll
Texas Bar No. 11616900
Russell T. Wong
Texas Bar No. 21884235
James H. Hall
Texas Bar No. 24041040
WONG, CABELLO, LUTSCH,
RUTHERFORD & BRUCCULERI, L.L.P.
20333 SH 249, Suite 600
Houston, TX 77070
Tel: 832-446-2400
Fax: 832-446-2424
sknoll@counselip.com
rwong@counselip.com
jhall@counselip.com

*ATTORNEYS FOR PLAINTIFF
CROSSROADS SYSTEMS, INC.*

TO: Mail Stop 8 Director of the U.S. Patent and Trademark Office P.O. Box 1450 Alexandria, VA 22313-1450	REPORT ON THE FILING OR DETERMINATION OF AN ACTION REGARDING A PATENT OR TRADEMARK
-----------------------------------------------------------------------------------------------------------------------------	-------------------------------------------------------------------------------------------------------

In Compliance with 35 U.S.C. § 290 and/or 15 U.S.C. § 1116 you are hereby advised that a court action has been filed in the U.S. District Court Western District of Texas, Austin Division on the following

Trademarks or Patents. (the patent action involves 35 U.S.C. § 292.):

DOCKET NO. 1:13-cv-895-SS	DATE FILED 10/7/2013	U.S. DISTRICT COURT Western District of Texas, Austin Division
PLAINTIFF Crossroads Systems, Inc.		DEFENDANT Oracle Corporation
PATENT OR TRADEMARK NO.	DATE OF PATENT OR TRADEMARK	HOLDER OF PATENT OR TRADEMARK
1 see attached		
2 6,425,035		
3 7,934,041		
4 7,051,147		
5		

In the above—entitled case, the following patent(s)/ trademark(s) have been included:

DATE INCLUDED	INCLUDED BY	<input type="checkbox"/> Amendment <input type="checkbox"/> Answer <input type="checkbox"/> Cross Bill <input type="checkbox"/> Other Pleading
PATENT OR TRADEMARK NO.	DATE OF PATENT OR TRADEMARK	HOLDER OF PATENT OR TRADEMARK
1		
2		
3		
4		
5		

In the above—entitled case, the following decision has been rendered or judgement issued:

DECISION/JUDGEMENT

CLERK William G. Putnicki	(BY) DEPUTY CLERK <i>Dga Schroeder</i>	DATE 10/7/2013
------------------------------	-------------------------------------------	-------------------

Copy 1—Upon initiation of action, mail this copy to Director Copy 3—Upon termination of action, mail this copy to Director
Copy 2—Upon filing document adding patent(s), mail this copy to Director Copy 4—Case file copy

- F. That Defendant has infringed the '041 Patent;
- G. That such infringement of the '041 Patent by Defendant has been willful;
- H. That Defendant accounts for and pays to Crossroads all damages caused by the infringement of the '041 Patent;
- I. That Crossroads receive enhanced damages from Defendant in the form of treble damages, pursuant to 35 U.S.C. § 284 based on Defendant's willful infringement of the '041 Patent;
- J. That Crossroads be granted pre-judgment and post-judgment interest on the damages caused to it by reason of Defendant's infringement of the '041 Patent, including pre-judgment and post-judgment interest on any enhanced damages or attorneys' fees award;
- K. That Defendant has infringed the '147 Patent;
- L. That such infringement of the '147 Patent by Defendant has been willful;
- M. That Defendant accounts for and pays to Crossroads all damages caused by the infringement of the '147 Patent;
- N. That Crossroads receive enhanced damages from Defendant in the form of treble damages, pursuant to 35 U.S.C. § 284 based on Defendant's willful infringement of the '147 Patent;
- O. That Crossroads be granted pre-judgment and post-judgment interest on the damages caused to it by reason of Defendant's infringement of the '147 Patent, including pre-judgment and post-judgment interest on any enhanced damages or attorneys' fees award;

- P. That Defendant pay Crossroads all of Crossroads' reasonable attorneys' fees and expenses;
- Q. That costs be awarded to Crossroads;
- R. That Defendant, its agents, employees, representatives, successors and assigns, and those acting in privity or in concert with it, be preliminary and permanently enjoined from further infringement of the '035 Patent;
- S. That Defendant, its agents, employees, representatives, successors and assigns, and those acting in privity or in concert with it, be preliminary and permanently enjoined from further infringement of the '041 Patent;
- T. That Defendant, its agents, employees, representatives, successors and assigns, and those acting in privity or in concert with it, be preliminary and permanently enjoined from further infringement of the '147 Patent;
- U. That this is an exceptional case under 35 U.S.C. § 285; and
- V. That Crossroads be granted such other and further relief as the Court may deem just and proper under the circumstances.

DEMAND FOR JURY TRIAL

Crossroads hereby demands a trial by jury on all issues.

Dated: October 7, 2013

Respectfully submitted,

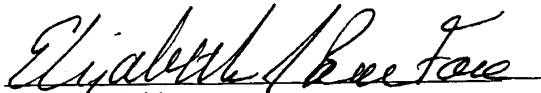
By: 

Steven Sprinkle
Texas Bar No. 00794962
Elizabeth J. Brown Fore
Texas Bar No. 24001795
Sprinkle IP Law Group, PC
1301 W. 25th Street, Suite 408
Austin, Texas 78705
Tel: 512-637-9220
Fax: 512-371-9088
ssprinkle@sprinklelaw.com
ebrownfore@sprinklelaw.com

Susan K. Knoll
Texas Bar No. 11616900
Russell R. Wong
Texas Bar No. 21884235
James H. Hall
Texas Bar No. 24041040
WONG, CABELLO, LUTSCH,
RUTHERFORD & BRUCCULERI, L.L.P.
20333 SH 249, Suite 600
Houston, TX 77070
Tel: 832-446-2400
Fax: 832-446-2424
sknoll@counselip.com
rwong@counselip.com
jhall@counselip.com

*ATTORNEYS FOR PLAINTIFF
CROSSROADS SYSTEMS, INC.*

IN THE UNITED STATES DISTRICT COURT
FOR THE WESTERN DISTRICT OF TEXAS
AUSTIN DIVISION

FILED
2013 OCT -7 PM 2:52
CLERK US DISTRICT COURT
WESTERN DISTRICT OF TEXAS

CROSSROADS SYSTEMS, INC.,

Plaintiff,

v.

ORACLE CORPORATION,

Defendant.

§
§
§
§
§
§
§
§
§
§
§
§

BY _____ OS

CIVIL ACTION NO. _____

JURY DEMANDED

A13CV0895 SS

**PLAINTIFF CROSSROADS SYSTEMS, INC.'S
COMPLAINT FOR PATENT INFRINGEMENT**

THE PARTIES

1. Plaintiff Crossroads Systems, Inc. ("Crossroads") is a corporation incorporated under the laws of the State of Delaware and has its principal place of business at 11000 North MoPac Expressway, Austin, Texas 78759.

2. Upon information and belief, Defendant Oracle Corporation ("Defendant") is a Delaware corporation with a principal place of business of 500 Oracle Parkway, Redwood City, CA 94065.

JURISDICTION AND VENUE

3. This action arises under the laws of the United States, more specifically under 35 U.S.C. § 100, *et seq.* Subject matter jurisdiction is proper in this Court pursuant to 28 U.S.C. §§ 1331 and 1338.

4. Personal jurisdiction and venue are proper in this district under 28 U.S.C. §§ 1391 and 1400(b). Upon information and belief, Defendant Oracle has established minimum contacts with this forum such that the exercise of jurisdiction over Defendant would not offend traditional notions of fair play and substantial justice.

5. This Court has personal jurisdiction over Oracle. Upon information and belief, Oracle regularly conducts business in the State of Texas and in this judicial district and is subject to the jurisdiction of this Court. Upon information and belief, Oracle has been doing business in Texas and this judicial district by distributing, marketing, selling and/or offering for sale its products, including, but not limited to, products that practice the subject matter claimed in the Patents-In-Suit, and/or regularly doing or soliciting business and/or engaging in other persistent courses of conduct in and/or directed to Texas and this judicial district.

COUNT 1: INFRINGEMENT OF U.S. PATENT NO. 6,425,035

6. Crossroads incorporates by reference the allegations set forth in the preceding paragraphs.

7. On July 23, 2002, United States Patent No. 6,425,035 (the "'035 Patent") was duly and legally issued. A true and correct copy of the '035 Patent is attached hereto as Exhibit A. Crossroads is the assignee and the owner of all right, title, and interest in and to the '035 Patent. The '035 Patent is entitled to a presumption of validity.

8. On information and belief, Defendant has directly infringed the '035 Patent. On information and belief, Defendant continues to directly infringe the '035 Patent.

9. Specifically, on information and belief, Defendant has directly infringed the '035 Patent by making, using, offering for sale, selling and/or importing into the United States certain of its products including at least the following: Sun ZFS Storage 7120 Appliance, Sun ZFS Storage 7320 Appliance, Sun ZFS Storage 7420 Appliance, Oracle Servers with Solaris with SCSI Target Mode Framework, Pillar Axiom 300 with Fibre Channel SAN Slammer, Pillar Axiom 300 with iSCSI SAN Slammer, Pillar Axiom 300 with Combination FC/iSCSI SAN Slammer, Pillar Axiom 600 with Fibre Channel SAN Slammer, Pillar Axiom 600 with iSCSI

SAN Slammer, Pillar Axiom 600 with Combination FC/iSCSI SAN Slammer, and Oracle Sun Storage 2540-M2 Array.

10. Further, on information and belief, Defendant has been and now is indirectly infringing by way of inducing infringement of the '035 Patent with knowledge of the '035 Patent by making, offering for sale, selling, importing into the United States, marketing, supporting, providing product instruction and/or advertising certain of its products, including the Sun ZFS Storage 7120 Appliance, Sun ZFS Storage 7320 Appliance, Sun ZFS Storage 7420 Appliance, Oracle Servers with Solaris with SCSI Target Mode Framework, Oracle Solaris with SCSI Target Mode Framework, Pillar Axiom 300 with Fibre Channel SAN Slammer, Pillar Axiom 300 with iSCSI SAN Slammer, Pillar Axiom 300 with Combination FC/iSCSI SAN Slammer, Pillar Axiom 600 with Fibre Channel SAN Slammer, Pillar Axiom 600 with iSCSI SAN Slammer, Pillar Axiom 600 with Combination FC/iSCSI SAN Slammer, and Oracle Sun Storage 2540-M2 Array, and Defendant knew that its actions were inducing end users to infringe the '035 Patent.

11. Further, on information and belief, Defendant has been and now is indirectly infringing by way of contributing to the infringement by end users of the '035 Patent by selling, offering to sell and/or importing into the United States components, including the Sun ZFS Storage 7120 Appliance, Sun ZFS Storage 7320 Appliance, Sun ZFS Storage 7420 Appliance, Oracle Servers with Solaris with SCSI Target Mode Framework, Oracle Solaris with SCSI Target Mode Framework, Pillar Axiom 300 with Fibre Channel SAN Slammer, Pillar Axiom 300 with iSCSI SAN Slammer, Pillar Axiom 300 with Combination FC/iSCSI SAN Slammer, Pillar Axiom 600 with Fibre Channel SAN Slammer, Pillar Axiom 600 with iSCSI SAN Slammer, Pillar Axiom 600 with Combination FC/iSCSI SAN Slammer, and Oracle Sun Storage

2540-M2 Array, knowing the components to be especially made or especially adapted for use in the infringement of the '035 Patent. Such components are not a staple article or commodity of commerce suitable for substantial non-infringing uses.

12. Defendant has been on constructive and/or actual notice of the '035 Patent since at least as early as November 2009, and Defendant has not ceased its infringing activities. The infringement of the '035 Patent by Defendant has been and continues to be willful and deliberate.

13. Crossroads has been irreparably harmed by Defendant's acts of infringement of the '035 Patent, and will continue to be harmed unless and until Defendant's acts of infringement are enjoined and restrained by order of this Court.

14. As a result of the acts of infringement of the '035 Patent by Defendant, Crossroads has suffered and will continue to suffer damages in an amount to be proven at trial.

COUNT 2: INFRINGEMENT OF U.S. PATENT NO. 7,934,041

15. Crossroads incorporates by reference the allegations set forth in the preceding paragraphs.

16. On April 26, 2011, United States Patent No. 7,934,041 (the "'041 Patent") was duly and legally issued. A true and correct copy of the '041 Patent is attached hereto as Exhibit B. Crossroads is the assignee and the owner of all right, title, and interest in and to the '041 Patent. The '041 Patent is entitled to a presumption of validity.

17. On information and belief, Defendant has directly infringed the '041 Patent. On information and belief, Defendant continues to directly infringe the '041 Patent.

18. Specifically, on information and belief, Defendant has directly infringed the '041 Patent by making, using, offering for sale, selling and/or importing into the United States certain of its products including at least the following: Sun ZFS Storage 7120 Appliance, Sun ZFS

Storage 7320 Appliance, Sun ZFS Storage 7420 Appliance, Oracle Servers with Solaris with SCSI Target Mode Framework, Pillar Axiom 300 with Fibre Channel SAN Slammer, Pillar Axiom 300 with iSCSI SAN Slammer, Pillar Axiom 300 with Combination FC/iSCSI SAN Slammer, Pillar Axiom 600 with Fibre Channel SAN Slammer, Pillar Axiom 600 with iSCSI SAN Slammer, Pillar Axiom 600 with Combination FC/iSCSI SAN Slammer, and Oracle Sun Storage 2540-M2 Array.

19. Further, upon information and belief, Defendant has been and now is indirectly infringing by way of inducing infringement of the '041 Patent with knowledge of the '041 Patent by making, offering for sale, selling, importing into the United States, marketing, supporting, providing product instruction and/or advertising certain of its products, including the Sun ZFS Storage 7120 Appliance, Sun ZFS Storage 7320 Appliance, Sun ZFS Storage 7420 Appliance, Oracle Servers with Solaris with SCSI Target Mode Framework, Oracle Solaris with SCSI Target Mode Framework, Pillar Axiom 300 with Fibre Channel SAN Slammer, Pillar Axiom 300 with iSCSI SAN Slammer, Pillar Axiom 300 with Combination FC/iSCSI SAN Slammer, Pillar Axiom 600 with Fibre Channel SAN Slammer, Pillar Axiom 600 with iSCSI SAN Slammer, Pillar Axiom 600 with Combination FC/iSCSI SAN Slammer, and Oracle Sun Storage 2540-M2 Array, and Defendant knew that its actions were inducing end users to infringe the '041 Patent.

20. Further, upon information and belief, Defendant has been and now is indirectly infringing by way of contributing to the infringement by end users of the '041 Patent by selling, offering to sell and/or importing into the United States components, including the Sun ZFS Storage 7120 Appliance, Sun ZFS Storage 7320 Appliance, Sun ZFS Storage 7420 Appliance, Oracle Servers with Solaris with SCSI Target Mode Framework, Oracle Solaris with SCSI

Target Mode Framework, Pillar Axiom 300 with Fibre Channel SAN Slammer, Pillar Axiom 300 with iSCSI SAN Slammer, Pillar Axiom 300 with Combination FC/iSCSI SAN Slammer, Pillar Axiom 600 with Fibre Channel SAN Slammer, Pillar Axiom 600 with iSCSI SAN Slammer, Pillar Axiom 600 with Combination FC/iSCSI SAN Slammer, and Oracle Sun Storage 2540-M2 Array, knowing the components to be especially made or especially adapted for use in the infringement of the '041 Patent. Such components are not a staple article or commodity of commerce suitable for substantial non-infringing uses.

21. Defendant has been on constructive and/or actual notice of the '041 Patent since at least as early as May 2011, and Defendant has not ceased its infringing activities. The infringement of the '041 Patent by Defendant has been and continues to be willful and deliberate.

22. Crossroads has been irreparably harmed by Defendant's acts of infringement of the '041 Patent, and will continue to be harmed unless and until Defendant's acts of infringement are enjoined and restrained by order of this Court.

23. As a result of the acts of infringement of the '041 Patent by Defendant, Crossroads has suffered and will continue to suffer damages in an amount to be proven at trial.

COUNT 3: INFRINGEMENT OF U.S. PATENT NO. 7,051,147

24. Crossroads incorporates by reference the allegations set forth in the preceding paragraphs.

25. On May 23, 2006, United States Patent No. 7,051,147 (the "'147 Patent") was duly and legally issued. A true and correct copy of the '147 Patent is attached hereto as Exhibit C. Crossroads is the assignee and the owner of all right, title, and interest in and to the '147 Patent. The '147 Patent is entitled to a presumption of validity.

26. On information and belief, Defendant has directly infringed the '147 Patent. On information and belief, Defendant continues to directly infringe the '147 Patent.

27. Specifically, on information and belief, Defendant has directly infringed the '147 Patent by making, using, offering for sale, selling and/or importing into the United States certain of its products including at least the following: Pillar Axiom 300 with Fibre Channel SAN Slammer, Pillar Axiom 300 with Combination FC/iSCSI SAN Slammer, Pillar Axiom 600 with Fibre Channel SAN Slammer, and the Pillar Axiom 600 with Combination FC/iSCSI SAN Slammer.

28. Further, on information and belief, Defendant has been and now is indirectly infringing by way of inducing infringement of the '147 Patent with knowledge of the '147 Patent by making, offering for sale, selling, importing into the United States, marketing, supporting, providing product instruction and/or advertising certain of its products, including the Pillar Axiom 300 with Fibre Channel SAN Slammer, Pillar Axiom 300 with Combination FC/iSCSI SAN Slammer, Pillar Axiom 600 with Fibre Channel SAN Slammer, and the Pillar Axiom 600 with Combination FC/iSCSI SAN Slammer, and Defendant knew that its actions were inducing end users to infringe the '147 Patent.

29. Further, on information and belief, Defendant has been and now is indirectly infringing by way of contributing to the infringement by end users of the '147 Patent by selling, offering to sell and/or importing into the United States components, including the Pillar Axiom 300 with Fibre Channel SAN Slammer, Pillar Axiom 300 with Combination FC/iSCSI SAN Slammer, Pillar Axiom 600 with Fibre Channel SAN Slammer, and the Pillar Axiom 600 with Combination FC/iSCSI SAN Slammer, knowing the components to be especially made or

especially adapted for use in the infringement of the '147 Patent. Such components are not a staple article or commodity of commerce suitable for substantial non-infringing uses.

30. Defendant has been on constructive and/or actual notice of the '147 Patent since at least as early as November 2009, and Defendant has not ceased its infringing activities. The infringement of the '147 Patent by Defendant has been and continues to be willful and deliberate.

31. Crossroads has been irreparably harmed by Defendant's acts of infringement of the '147 Patent, and will continue to be harmed unless and until Defendant's acts of infringement are enjoined and restrained by order of this Court.

32. As a result of the acts of infringement of the '147 Patent by Defendant, Crossroads has suffered and will continue to suffer damages in an amount to be proven at trial.

PRAYER FOR RELIEF

WHEREFORE, Crossroads requests this Court enter judgment as follows:

- A. That Defendant has infringed the '035 Patent;
- B. That such infringement of the '035 Patent by Defendant has been willful;
- C. That Defendant accounts for and pays to Crossroads all damages caused by the infringement of the '035 Patent;
- D. That Crossroads receive enhanced damages from Defendant in the form of treble damages, pursuant to 35 U.S.C. § 284 based on Defendant's willful infringement of the '035 Patent;
- E. That Crossroads be granted pre-judgment and post-judgment interest on the damages caused to it by reason of Defendant's infringement of the '035 Patent, including pre-judgment and post-judgment interest on any enhanced damages or attorneys' fees award;

TO: Mail Stop 8 Director of the U.S. Patent and Trademark Office P.O. Box 1450 Alexandria, VA 22313-1450	REPORT ON THE FILING OR DETERMINATION OF AN ACTION REGARDING A PATENT OR TRADEMARK
-----------------------------------------------------------------------------------------------------------------------------------------------	-------------------------------------------------------------------------------------------------------------------------

In Compliance with 35 U.S.C. § 290 and/or 15 U.S.C. § 1116 you are hereby advised that a court action has been filed in the U.S. District Court Western District of Texas, Austin Division on the following

Trademarks or Patents. (the patent action involves 35 U.S.C. § 292.):

DOCKET NO. 1:12-CV-1090-SS	DATE FILED 11/27/2012	U.S. DISTRICT COURT Western District of Texas, Austin Division
PLAINTIFF Crossroads Systems, Inc.		DEFENDANT Addonics Technologies, Inc.
PATENT OR TRADEMARK NO.	DATE OF PATENT OR TRADEMARK	HOLDER OF PATENT OR TRADEMARK
1 see attached		
2 6,425,035		
3 7,934,041		
4		
5		

In the above—entitled case, the following patent(s)/ trademark(s) have been included:

DATE INCLUDED	INCLUDED BY	<input type="checkbox"/> Amendment <input type="checkbox"/> Answer <input type="checkbox"/> Cross Bill <input type="checkbox"/> Other Pleading
PATENT OR TRADEMARK NO.	DATE OF PATENT OR TRADEMARK	HOLDER OF PATENT OR TRADEMARK
1		
2		
3		
4		
5		

In the above—entitled case, the following decision has been rendered or judgement issued:

DECISION/JUDGEMENT

CLERK William G. Putnicki	(BY) DEPUTY CLERK <i>Jennifer Williams</i>	DATE 11/28/2012
------------------------------	-----------------------------------------------	--------------------

Copy 1—Upon initiation of action, mail this copy to Director Copy 2—Upon termination of action, mail this copy to Director
 Copy 2—Upon filing document adding patent(s), mail this copy to Director Copy 4—Case file copy

IN THE UNITED STATES DISTRICT COURT
FOR THE WESTERN DISTRICT OF TEXAS
AUSTIN DIVISION

CROSSROADS SYSTEMS, INC.,	§	
	§	
Plaintiff,	§	
	§	CIVIL ACTION NO. 1:12-CV-1090
v.	§	
	§	JURY DEMANDED
ADDONICS TECHNOLOGIES, INC.,	§	
	§	
Defendant.	§	

**PLAINTIFF CROSSROADS SYSTEMS, INC.'S
COMPLAINT FOR PATENT INFRINGEMENT**

THE PARTIES

1. Plaintiff Crossroads Systems, Inc. ("Crossroads") is a corporation incorporated under the laws of the State of Delaware and has its principal place of business at 11000 North MoPac Expressway, Austin, Texas 78759.

2. Upon information and belief, Defendant Addonics Technologies, Inc. ("Addonics") is a California corporation with a principal place of business of 1918 Junction Avenue, San Jose, CA 95131.

JURISDICTION AND VENUE

3. This action arises under the laws of the United States, more specifically under 35 U.S.C. § 100, *et seq.* Subject matter jurisdiction is proper in this Court pursuant to 28 U.S.C. §§ 1331 and 1338.

4. Personal jurisdiction and venue are proper in this district under 28 U.S.C. §§ 1391 and 1400. Upon information and belief, Defendant has established minimum contacts with this forum such that the exercise of jurisdiction over Defendant would not offend traditional notions of fair play and substantial justice.

5. Addonics is subject to this Court's specific and general personal jurisdiction pursuant to due process and/or the Texas Long Arm Statute, because, upon information and belief, Addonics has been doing business in Texas and this judicial district by distributing, marketing, selling and/or offering for sale its products, including, but not limited to, products that practice the subject matter claimed in the Patents-In-Suit, and/or regularly doing or soliciting business and/or engaging in other persistent courses of conduct in and/or directed to Texas and this judicial district including, at least by advertising and making available their infringing systems and/or methods through the Internet in such a way as to reach customers in this judicial district.

COUNT 1: INFRINGEMENT OF U.S. PATENT NO. 6,425,035

6. Crossroads incorporates by reference the allegations set forth in the preceding paragraphs.

7. On July 23, 2002, United States Patent No. 6,425,035 (the "'035 Patent") was duly and legally issued. A true and correct copy of the '035 Patent is attached hereto as Exhibit A. Crossroads is the assignee and the owner of all right, title, and interest in and to the '035 Patent. The '035 Patent is entitled to a presumption of validity.

8. Defendant Addonics has directly infringed the '035 Patent. On information and belief, Defendant continues to directly infringe the '035 Patent.

9. Specifically, Defendant has directly infringed the '035 Patent by making, using, offering for sale, selling and/or importing into the United States certain of its products including at least the following: Addonics ISC8P2G-S and ISC16P2G-S iSCSI Subsystems, Addonics iSCSI Rack, Addonics Storage Rack with ISC8P2G, Addonics SAN Tower (also referred to as

Addonics SAN Storage Tower), and Addonics SAN Tower II (also referred to as Addonics SAN Storage Tower II).

10. Further, Defendant has been and now is indirectly infringing by way of inducing infringement of the '035 Patent with knowledge of the '035 Patent by making, offering for sale, selling, importing into the United States, marketing, supporting, providing product instruction and/or advertising certain of its products, including the Addonics ISC8P2G-S and ISC16P2G-S iSCSI Subsystems, Addonics iSCSI Rack, Addonics Storage Rack with ISC8P2G, Addonics SAN Tower (also referred to as Addonics SAN Storage Tower), and Addonics SAN Tower II (also referred to as Addonics SAN Storage Tower II), and Defendant knew that its actions were inducing end users to infringe the '035 Patent.

11. Further, Defendant has been and now is indirectly infringing by way of contributing to the infringement by end users of the '035 Patent by selling, offering to sell and/or importing into the United States components, including the Addonics ISC8P2G-S and ISC16P2G-S iSCSI Subsystems, Addonics iSCSI Rack, Addonics Storage Rack with ISC8P2G, Addonics SAN Tower (also referred to as Addonics SAN Storage Tower), and Addonics SAN Tower II (also referred to as Addonics SAN Storage Tower II), knowing the components to be especially made or especially adapted for use in the infringement of the '035 Patent. Such components are not a staple article or commodity of commerce suitable for substantial non-infringing uses.

12. Defendant has been on constructive and/or actual notice of the '035 Patent since before this lawsuit and Defendant has not ceased its infringing activities. The infringement of the '035 Patent by Defendant has been and continues to be willful and deliberate.

13. Crossroads has been irreparably harmed by Defendant's acts of infringement of the '035 Patent, and will continue to be harmed unless and until Defendant's acts of infringement are enjoined and restrained by order of this Court.

14. As a result of the acts of infringement of the '035 Patent by Defendant, Crossroads has suffered and will continue to suffer damages in an amount to be proven at trial.

COUNT 2: INFRINGEMENT OF U.S. PATENT NO. 7,934,041

15. Crossroads incorporates by reference the allegations set forth in the preceding paragraphs.

16. On April 26, 2011, United States Patent No. 7,934,041 (the "'041 Patent") was duly and legally issued. A true and correct copy of the '041 Patent is attached hereto as Exhibit B. Crossroads is the assignee and the owner of all right, title, and interest in and to the '041 Patent. The '041 Patent is entitled to a presumption of validity.

17. Defendant Addonics has directly infringed the '041 Patent. On information and belief, Defendant continues to directly infringe the '041 Patent.

18. Specifically, Defendant has directly infringed the '041 Patent by making, using, offering for sale, selling and/or importing into the United States certain of its products including at least the following: Addonics ISC8P2G-S and ISC16P2G-S iSCSI Subsystems, Addonics iSCSI Rack, Addonics Storage Rack with ISC8P2G, Addonics SAN Tower (also referred to as Addonics SAN Storage Tower), and Addonics SAN Tower II (also referred to as Addonics SAN Storage Tower II).

19. Further, Defendant has been and now is indirectly infringing by way of inducing infringement of the '041 Patent with knowledge of the '041 Patent by making, offering for sale, selling, importing into the United States, marketing, supporting, providing product instruction

and/or advertising certain of its products, including the Addonics ISC8P2G-S and ISC16P2G-S iSCSI Subsystems, Addonics iSCSI Rack, Addonics Storage Rack with ISC8P2G, Addonics SAN Tower (also referred to as Addonics SAN Storage Tower), and Addonics SAN Tower II (also referred to as Addonics SAN Storage Tower II), and Defendant knew that its actions were inducing end users to infringe the '041 Patent.

20. Further, Defendant has been and now is indirectly infringing by way of contributing to the infringement by end users of the '041 Patent by selling, offering to sell and/or importing into the United States components, including the Addonics ISC8P2G-S and ISC16P2G-S iSCSI Subsystems, Addonics iSCSI Rack, Addonics Storage Rack with ISC8P2G, Addonics SAN Tower (also referred to as Addonics SAN Storage Tower), and Addonics SAN Tower II (also referred to as Addonics SAN Storage Tower II), knowing the components to be especially made or especially adapted for use in the infringement of the '041 Patent. Such components are not a staple article or commodity of commerce suitable for substantial non-infringing uses.

21. Defendant has been on constructive and/or actual notice of the '041 Patent since before this lawsuit and Defendant has not ceased its infringing activities. The infringement of the '041 Patent by Defendant has been and continues to be willful and deliberate.

22. Crossroads has been irreparably harmed by Defendant Addonics' acts of infringement of the '041 Patent, and will continue to be harmed unless and until Defendant Addonics' acts of infringement are enjoined and restrained by order of this Court.

23. As a result of the acts of infringement of the '041 Patent by Defendant, Crossroads has suffered and will continue to suffer damages in an amount to be proven at trial.

PRAYER FOR RELIEF

WHEREFORE, Crossroads requests this Court enter judgment as follows:

- A. That Defendant Addonics has infringed the '035 Patent;
- B. That such infringement of the '035 Patent by Defendant has been willful;
- C. That Defendant accounts for and pays to Crossroads all damages caused by the infringement of the '035 Patent;
- D. That Crossroads receive enhanced damages from Defendant in the form of treble damages, pursuant to 35 U.S.C. § 284 based on Defendant's willful infringement of the '035 Patent;
- E. That Crossroads be granted pre-judgment and post-judgment interest on the damages caused to it by reason of Defendant's infringement of the '035 Patent, including pre-judgment and post-judgment interest on any enhanced damages or attorneys' fees award;
- F. That Defendant Addonics has infringed the '041 Patent;
- G. That such infringement of the '041 Patent by Defendant has been willful;
- H. That Defendant accounts for and pays to Crossroads all damages caused by the infringement of the '041 Patent;
- I. That Crossroads receive enhanced damages from Defendant in the form of treble damages, pursuant to 35 U.S.C. § 284 based on Defendant Addonics' willful infringement of the '041 Patent;
- J. That Crossroads be granted pre-judgment and post-judgment interest on the damages caused to it by reason of Defendant's infringement of the

- '041 Patent, including pre-judgment and post-judgment interest on any enhanced damages or attorneys' fees award;
- K. That Defendant pay Crossroads all of Crossroads' reasonable attorneys' fees and expenses;
 - L. That costs be awarded to Crossroads;
 - M. That Defendant, its agents, employees, representatives, successors and assigns, and those acting in privity or in concert with it, be preliminary and permanently enjoined from further infringement of the '035 Patent;
 - N. That Defendant, its agents, employees, representatives, successors and assigns, and those acting in privity or in concert with it, be preliminary and permanently enjoined from further infringement of the '041 Patent;
 - O. That this is an exceptional case under 35 U.S.C. § 285; and
 - P. That Crossroads be granted such other and further relief as the Court may deem just and proper under the circumstances.

DEMAND FOR JURY TRIAL

Crossroads hereby demands a trial by jury on all issues.

Dated: November 27, 2012

Respectfully submitted,

By: /s/ Elizabeth J. Brown Fore

Steven Sprinkle
State Bar No. 00794962
Elizabeth J. Brown Fore
State Bar No. 24001795
Sprinkle IP Law Group, PC
1301 W. 25th Street, Suite 408
Austin, Texas 78705
Tel: (512) 637-9220
Fax: (512) 371-9088
ssprinkle@sprinklelaw.com
ebrownfore@sprinklelaw.com

*ATTORNEYS FOR PLAINTIFF
CROSSROADS SYSTEMS, INC.*

TO: Mail Stop 8 Director of the U.S. Patent and Trademark Office P.O. Box 1450 Alexandria, VA 22313-1450	REPORT ON THE FILING OR DETERMINATION OF AN ACTION REGARDING A PATENT OR TRADEMARK
-----------------------------------------------------------------------------------------------------------------------------------------------	-------------------------------------------------------------------------------------------------------------------------

In Compliance with 35 U.S.C. § 290 and/or 15 U.S.C. § 1116 you are hereby advised that a court action has been filed in the U.S. District Court Western District of Texas, Austin Division on the following

Trademarks or Patents. (the patent action involves 35 U.S.C. § 292.):

DOCKET NO. 1:12-CV-104 SS	DATE FILED 2/1/2012	U.S. DISTRICT COURT Western District of Texas, Austin Division
PLAINTIFF Crossroads Systems, Inc.		DEFENDANT Infotrend Corporation; Aberdeen LLC; Boost Systems, Inc.; iXsystems, Inc.; and Storageflex, Inc.
PATENT OR TRADEMARK NO.	DATE OF PATENT OR TRADEMARK	HOLDER OF PATENT OR TRADEMARK
1 see attached		
2 6,425,035		
3 7,051,147		
4 7,934,041		
5 7,934,040		

In the above—entitled case, the following patent(s)/ trademark(s) have been included:

DATE INCLUDED	INCLUDED BY	<input type="checkbox"/> Amendment <input type="checkbox"/> Answer <input type="checkbox"/> Cross Bill <input type="checkbox"/> Other Pleading
PATENT OR TRADEMARK NO.	DATE OF PATENT OR TRADEMARK	HOLDER OF PATENT OR TRADEMARK
1 7,987,311		
2		
3		
4		
5		

In the above—entitled case, the following decision has been rendered or judgement issued:

DECISION/JUDGEMENT

CLERK William G. Putnicki	(BY) DEPUTY CLERK <i>Debra Schroed</i>	DATE 2/2/2012
------------------------------	-------------------------------------------	------------------

Copy 1—Upon initiation of action, mail this copy to Director Copy 3—Upon termination of action, mail this copy to Director
 Copy 2—Upon filing document adding patent(s), mail this copy to Director Copy 4—Case file copy

infringement, by way of actively inducing infringement and/or contributing to the infringement of the '147 Patent by users of Defendant Boost products, such as EonStor Fibre-to-Fibre RAID Systems by, among other things, making, using, offering for sale, selling, importing into the United States, marketing, supporting, providing product instruction, and/or advertising certain of its products, including the EonStor Fibre-to-Fibre RAID Systems.

32. Further, Defendant Storageflex has been and now is indirectly infringing the '147 Patent, with knowledge of the patent and knowledge that its induced acts constitute patent infringement, by way of actively inducing infringement and/or contributing to the infringement of the '147 Patent by users of Defendant Storageflex's products, such as the FF1124 by, among other things, making, using, offering for sale, selling, importing into the United States, marketing, supporting, promoting, providing product instruction, and/or advertising certain of its products and/or certain components for use with Storageflex's products, including the FF1124 and/or components for use with same.

33. Defendants Infortrend, Boost and Storageflex have been on notice of the '147 Patent since before this lawsuit through notification by letter (Boost, Storageflex), prior involvement in litigation involving the '147 Patent (Infortrend), and/or purchase of a marked product (Storageflex), and have not ceased their infringing activities. The infringement of the '147 Patent by Defendants Infortrend, Boost and Storageflex has been and continues to be willful and deliberate.

34. Crossroads has been irreparably harmed by each of Defendant Infortrend's, Boost's and Storageflex's acts of infringement of the '147 Patent and will continue to be harmed unless and until each of Defendant Infortrend's, Boost's and Storageflex's acts of infringement are enjoined and restrained by order of this Court.

35. As a result of the acts of infringement of the '147 Patent by Defendants Infortrend, Boost and Storageflex, Crossroads has suffered and will continue to suffer damages in an amount to be proven at trial.

COUNT 3: INFRINGEMENT OF U.S. PATENT NO. 7,934,041

36. Crossroads incorporates by reference the allegations set forth in the preceding paragraphs.

37. On April 26, 2011, United States Patent No. 7,934,041 (the "'041 Patent'") was duly and legally issued. A true and correct copy of the '041 Patent is attached hereto as Exhibit C. Crossroads is the assignee and the owner of all right, title, and interest in and to the '041 Patent. The '041 Patent is entitled to a presumption of validity.

38. Defendants Infortrend, Aberdeen, Boost, iXsystems and Storageflex have directly infringed the '041 Patent. On information and belief, the Defendants continue to directly infringe the '041 Patent.

39. Specifically, each of the Defendants has directly infringed the '041 Patent by making, using, offering for sale, selling and/or importing into the United States certain of their products including at least the following: EonStor RAID Systems with Fibre Host Interface and/or iSCSI Host Interface, EonStor DS RAID Systems with Fibre Host Interface and/or iSCSI Host Interface, ESVA iSCSI Host Series and ESVA Fibre Host Series (Infortrend); XDAS D-Series RAID Systems with FC and/or iSCSI Host, XDAS iSCSI Series RAID Systems, XDAS F8 Series RAID Systems and Aberdeen P8 XDAS with Fibre Host Interface (Aberdeen); EonStor RAID Systems with Fibre Host Interface and/or iSCSI Host Interface, EonStor DS RAID Systems with Fibre Host Interface and/or iSCSI Host Interface, ESVA iSCSI Host Series and ESVA Fibre Host Series (Boost); Titan 316F, Titan 424F, ESVA iSCSI Host Series and

ESVA Fibre Host Series (iXsystems); and FF1124 and HA3969 with FC or iSCSI Host Interfaces (Storageflex).

40. Further, Defendant Aberdeen has been and now is indirectly infringing the '041 Patent, with knowledge of the patent and knowledge that its induced acts constitute patent infringement, by way of actively inducing infringement and/or contributing to the infringement of the '041 Patent by users of Defendant Aberdeen's products, such as XDAS D-Series RAID Systems with FC and/or iSCSI Host, XDAS iSCSI Series RAID Systems, XDAS F8 Series RAID Systems and Aberdeen P8 XDAS with Fibre Host Interface by among other things, making, using, offering for sale, selling, importing into the United States, marketing, supporting, providing product instruction, and/or advertising certain of Defendant Aberdeen's products, including XDAS D-Series RAID Systems with FC and/or iSCSI Host, XDAS iSCSI Series RAID Systems, XDAS F8 Series RAID Systems and Aberdeen P8 XDAS with Fibre Host Interface.

41. Further, Defendant Boost has been and now is indirectly infringing the '041 Patent, with knowledge of the patent and knowledge that its induced acts constitute patent infringement, by way of actively inducing infringement and/or contributing to the infringement of the '041 Patent by users of Defendant Boost's products, such as EonStor RAID Systems with Fibre Host Interface and/or iSCSI Host Interface, EonStor DS RAID Systems with Fibre Host Interface and/or iSCSI Host Interface, ESVA iSCSI Host Series, and ESVA Fibre Host Series by among other things, making, using, offering for sale, selling, importing into the United States, marketing, supporting, providing product instruction, and/or advertising certain of Defendant Boost's products, including the EonStor RAID Systems with Fibre Host Interface and/or iSCSI

Host Interface, EonStor DS RAID Systems with Fibre Host Interface and/or iSCSI Host Interface, ESVA iSCSI Host Series, and ESVA Fibre Host Series.

42. Further, Defendant iXsystems has been and now is indirectly infringing the '041 Patent, with knowledge of the patent, by way of contributing to the infringement of the '041 Patent by users of Defendant iXsystems' products, such as Titan 316F, Titan 424F, ESVA iSCSI Host Series, and ESVA Fibre Host Series by among other things, offering for sale, selling, and/or importing into the United States certain of Defendant iXsystems' products, including Titan 316F, Titan 424F, ESVA iSCSI Host Series, and/or ESVA Fibre Host Series.

43. Further, Defendant Storageflex has been and now is indirectly infringing the '041 Patent, with knowledge of the patent and knowledge that its induced acts constitute patent infringement, by way of actively inducing infringement and/or contributing to the infringement of the '041 Patent by users of Defendant Storageflex's products, such as the FF1124 and HA3969 with FC or iSCSI Host Interfaces by among other things, making, using, offering for sale, selling, importing into the United States, marketing, supporting, promoting, providing product instruction, and/or advertising certain of Defendant Storageflex's products and/or components for use with same, including, without limitation, the FF1124 and HA3969 with FC or iSCSI Host Interfaces and/or components for use with same.

44. Defendants Aberdeen, Boost, iXsystems and Storageflex have been on notice of the '041 Patent since before this lawsuit through notification by letter that their products, including, but not limited to, the infringing products listed herein, have infringed and continue to infringe the '041 Patent, and have not ceased their infringing activities. The infringement of the '041 Patent by Defendants Aberdeen, Boost, iXsystems and Storageflex has been and continues to be willful and deliberate.

45. Crossroads has been irreparably harmed by each of Defendant Infortrend's, Boost's, Aberdeen's, iXsystems' and Storageflex's acts of infringement of the '041 Patent, and will continue to be harmed unless and until of Defendant Infortrend's, Boost's, Aberdeen's, iXsystems' and Storageflex's acts of infringement are enjoined and restrained by order of this Court.

46. As a result of the acts of infringement of the '041 Patent by Defendants, Crossroads has suffered and will continue to suffer damages in an amount to be proven at trial.

COUNT 4: INFRINGEMENT OF U.S. PATENT NO. 7,934,040

47. Crossroads incorporates by reference the allegations set forth in the preceding paragraphs.

48. On April 26, 2011, United States Patent No. 7,934,040 (the "'040 Patent") was duly and legally issued. A true and correct copy of the '040 Patent is attached hereto as Exhibit D. Crossroads is the assignee and the owner of all right, title, and interest in and to the '040 Patent. The '040 Patent is entitled to a presumption of validity.

49. Defendants Infortrend, Aberdeen, Boost, iXsystems and Storageflex have each directly infringed the '040 Patent. On information and belief, each Defendant continues to directly infringe the '040 Patent.

50. Specifically, each of the Defendants has directly infringed the '040 Patent by making, using, offering for sale, selling and/or importing into the United States certain of their products including at least the following: EonStor RAID Systems with Fibre Host Interface and/or iSCSI Host Interface, EonStor DS RAID Systems with Fibre Host Interface and/or iSCSI Host Interface, ESVA iSCSI Host Series and ESVA Fibre Host Series (Infortrend); XDAS D-Series RAID Systems with FC and/or iSCSI Host, XDAS iSCSI Series RAID Systems, XDAS

F8 Series RAID Systems and Aberdeen P8 XDAS with Fibre Host Interface (Aberdeen); EonStor RAID Systems with Fibre Host Interface and/or iSCSI Host Interface, EonStor DS RAID Systems with Fibre Host Interface and/or iSCSI Host Interface, ESVA iSCSI Host Series and ESVA Fibre Host Series (Boost); Titan 316F, Titan 424F, ESVA iSCSI Host Series and ESVA Fibre Host Series (iXsystems); and FF1124 and HA3969 FC or iSCSI Host Interfaces (Storageflex).

51. Further, Defendant Aberdeen has been and now is indirectly infringing the '040 Patent, with knowledge of the patent and knowledge that its induced acts constitute patent infringement, by way of actively inducing infringement and/or contributing to the infringement of the '040 Patent by users of Defendant Aberdeen's products, such as XDAS D-Series RAID Systems with FC and/or iSCSI Host, XDAS iSCSI Series RAID Systems, XDAS F8 Series RAID Systems and Aberdeen P8 XDAS with Fibre Host Interface by among other things, making, using, offering for sale, selling, importing into the United States, marketing, supporting, providing product instruction, and/or advertising certain of Defendant Aberdeen's products, including XDAS D-Series RAID Systems with FC and/or iSCSI Host, XDAS iSCSI Series RAID Systems, XDAS F8 Series RAID Systems and Aberdeen P8 XDAS with Fibre Host Interface.

52. Further, Defendant Boost has been and now is indirectly infringing the '040 Patent, with knowledge of the patent and knowledge that its induced acts constitute patent infringement, by way of actively inducing infringement and/or contributing to the infringement of the '040 Patent by users of Defendant Boost's products, such as EonStor RAID Systems with Fibre Host Interface and/or iSCSI Host Interface, EonStor DS RAID Systems with Fibre Host Interface and/or iSCSI Host Interface, ESVA iSCSI Host Series, and ESVA Fibre Host Series by

among other things, making, using, offering for sale, selling, importing into the United States, marketing, supporting, providing product instruction, and/or advertising certain of Defendant Boost's products, including the EonStor RAID Systems with Fibre Host Interface and/or iSCSI Host Interface, EonStor DS RAID Systems with Fibre Host Interface and/or iSCSI Host Interface, ESVA iSCSI Host Series, and ESVA Fibre Host Series.

53. Further, Defendant iXsystems has been and now is indirectly infringing the '040 Patent, with knowledge of the patent, by way of contributing to the infringement of the '040 Patent by users of Defendant iXsystems' products, such as the Titan 316F, Titan 424F, ESVA iSCSI Host Series and ESVA Fibre Host Series by among other things, offering for sale, selling, and/or importing into the United States certain of Defendant iXsystems' products, including the Titan 316F, Titan 424F, ESVA iSCSI Host Series and ESVA Fibre Host Series.

54. Further, Defendant Storageflex has been and now is indirectly infringing the '040 Patent, with knowledge of the patent and knowledge that its induced acts constitute patent infringement, by way of actively inducing infringement and/or contributing to the infringement of the '040 Patent by users of Defendant Storageflex's products, such as the FF1124 and HA3969 with FC or iSCSI Host Interfaces by among other things, making, using, offering for sale, selling, importing into the United States, marketing, supporting, promoting, providing product instruction, and/or advertising certain of Defendant Storageflex's products and/or components for use with same, including, without limitation, the FF1124 and HA3969 with FC or iSCSI Host Interfaces and/or components for use with same.

55. Defendants Aberdeen, Boost, iXsystems and Storageflex have been on notice of the '040 Patent since before this lawsuit through notification by letter that their products, including, but not limited to, the infringing products listed herein, have infringed and continued

to infringe, and have not ceased their infringing activities. The infringement of the '040 Patent by Defendants Aberdeen, Boost, iXsystems and Storageflex has been and continues to be willful and deliberate.

56. Crossroads has been irreparably harmed by each of Defendant Storageflex's, Aberdeen's, iXsystems', Boost's and Infortrend's acts of infringement of the '040 Patent, and will continue to be harmed unless and until each of Defendant Storageflex's, Aberdeen's, iXsystems', Boost's and Infortrend's acts of infringement are enjoined and restrained by order of this Court.

57. As a result of the acts of infringement of the '040 Patent by Defendants, Crossroads has suffered and will continue to suffer damages in an amount to be proven at trial.

COUNT 5: INFRINGEMENT OF U.S. PATENT NO. 7,987,311

58. Crossroads incorporates by reference the allegations set forth in the preceding paragraphs.

59. On July 26, 2011, United States Patent No. 7,987,311 (the "'311 Patent'") was duly and legally issued. A true and correct copy of the '311 Patent is attached hereto as Exhibit E. Crossroads is the assignee and the owner of all right, title, and interest in and to the '311 Patent. The '311 Patent is entitled to a presumption of validity.

60. Defendants Infortrend, Aberdeen, Boost, iXsystems and Storageflex have each directly infringed the '311 Patent. On information and belief, each Defendant continues to directly infringe the '311 Patent.

61. Specifically, each of the Defendants has directly infringed the '311 Patent by making, using, offering for sale, selling and/or importing into the United States certain of their products including at least the following: EonStor RAID Systems with Fibre Host Interface

and/or iSCSI Host Interface, EonStor DS RAID Systems with Fibre Host Interface and/or iSCSI Host Interface, ESVA iSCSI Host Series and ESVA Fibre Host Series (Infortrend); XDAS D-Series RAID Systems with FC and/or iSCSI Host, XDAS iSCSI Series RAID Systems, XDAS F8 Series RAID Systems and Aberdeen P8 XDAS with Fibre Host Interface (Aberdeen); EonStor RAID Systems with Fibre Host Interface and/or iSCSI Host Interface, EonStor DS RAID Systems with Fibre Host Interface and/or iSCSI Host Interface, ESVA iSCSI Host Series and ESVA Fibre Host Series (Boost); Titan 316F, Titan 424F, ESVA iSCSI Host Series and ESVA Fibre Host Series (iXsystems); and FF1124 and HA3969 FC or iSCSI Host Interfaces (Storageflex).

62. Further, Defendant Boost has been and now is indirectly infringing the '311 Patent, with knowledge of the patent and knowledge that its induced acts constitute patent infringement, by way of actively inducing infringement and/or contributing to the infringement of the '311 Patent by users of Defendant Boost's products, such as EonStor RAID Systems with Fibre Host Interface and/or iSCSI Host Interface, EonStor DS RAID Systems with Fibre Host Interface and/or iSCSI Host Interface, ESVA iSCSI Host Series, and ESVA Fibre Host Series by among other things, making, using, offering for sale, selling, importing into the United States, marketing, supporting, providing product instruction, and/or advertising certain of Defendant Boost's products, including the EonStor RAID Systems with Fibre Host Interface and/or iSCSI Host Interface, EonStor DS RAID Systems with Fibre Host Interface and/or iSCSI Host Interface, ESVA iSCSI Host Series, and ESVA Fibre Host Series.

63. Further, Defendant Storageflex has been and now is indirectly infringing the '311 Patent, with knowledge of the patent and knowledge that its induced acts constitute patent infringement, by way of actively inducing infringement and/or contributing to the infringement

of the '311 Patent by users of Defendant Storageflex's products, such as the FF1124 and HA3969 with FC or iSCSI Host Interfaces by among other things, making, using, offering for sale, selling, importing into the United States, marketing, supporting, promoting, providing product instruction, and/or advertising certain of Defendant Storageflex's products and/or components for use with same, including, without limitation, the FF1124 and HA3969 with FC or iSCSI Host Interfaces and/or components for use with same.

64. Defendants Boost and Storageflex have been on notice of the '311 Patent since before this lawsuit through notification by letter that their products, including, but not limited to, the infringing products listed herein, have infringed and continued to infringe, and have not ceased their infringing activities. The infringement of the '311 Patent by Defendants Boost and Storageflex has been and continues to be willful and deliberate.

65. Crossroads has been irreparably harmed by each of Defendant Storageflex's, Aberdeen's, iXsystems', Boost's and Infortrend's acts of infringement of the '311 Patent, and will continue to be harmed unless and until each of Defendant Storageflex's, Aberdeen's, iXsystems', Boost's and Infortrend's acts of infringement are enjoined and restrained by order of this Court.

66. As a result of the acts of infringement of the '311 Patent by Defendants, Crossroads has suffered and will continue to suffer damages in an amount to be proven at trial.

PRAYER FOR RELIEF

WHEREFORE, Crossroads requests this Court enter judgment as follows:

- A. That each of the Defendants has infringed the '035 Patent;
- B. That such infringement of the '035 Patent by Defendants has been willful;

IN THE UNITED STATES DISTRICT COURT
FOR THE WESTERN DISTRICT OF TEXAS
AUSTIN DIVISION

CROSSROADS SYSTEMS, INC.,	§	
	§	
Plaintiff,	§	
	§	CIVIL ACTION NO. 1:12-CV-104
v.	§	
	§	JURY DEMANDED
(1) INFORTREND CORPORATION,	§	
(2) ABERDEEN LLC,	§	
(3) BOOST SYSTEMS, INC.,	§	
(4) IXSYSTEMS, INC., and	§	
(5) STORAGEFLEX, INC.,	§	
	§	
Defendants.	§	

**PLAINTIFF CROSSROADS SYSTEMS, INC.'S
COMPLAINT FOR PATENT INFRINGEMENT**

THE PARTIES

1. Plaintiff Crossroads Systems, Inc. (“Crossroads”) is a corporation incorporated under the laws of the State of Delaware and has its principal place of business at 11000 North MoPac Expressway, Austin, Texas 78759.

2. Upon information and belief, Defendant Infortrend Corporation (“Infortrend”) is a California corporation with a principal place of business of 2200 Zanker Road, Suite 130, San Jose, CA 95131.

3. Upon information and belief, Defendant Aberdeen LLC (“Aberdeen”) is a California company with a principal place of business of 10420 Pioneer Boulevard, Santa Fe Springs, CA 90670.

4. Upon information and belief, Defendant Boost Systems, Inc. (“Boost”) is a California corporation with a principal place of business of 11391 Sunrise Gold Circle, Suite 300, Rancho Cordova, CA 95742.

- C. That Defendants account for and pay to Crossroads all damages caused by the infringement of the '035 Patent;
- D. That Crossroads receive enhanced damages from Defendants in the form of treble damages, pursuant to 35 U.S.C. § 284 based on Defendants' willful infringement of the '035 Patent;
- E. That Crossroads be granted pre-judgment and post-judgment interest on the damages caused to it by reason of Defendants' infringement of the '035 Patent, including pre-judgment and post-judgment interest on any enhanced damages or attorneys' fees award;
- F. That Defendants Infortrend, Boost and Storageflex have infringed the '147 Patent;
- G. That such infringement of the '147 Patent by Defendants Infortrend, Boost and Storageflex has been willful;
- H. That Defendants Infortrend, Boost and Storageflex account for and pay to Crossroads all damages caused by the infringement of the '147 Patent;
- I. That Crossroads receive enhanced damages from Defendants Infortrend, Boost and Storageflex in the form of treble damages, pursuant to 35 U.S.C. § 284 based on Defendants Infortrend, Boost and Storageflex's willful infringement of the '147 Patent;
- J. That Crossroads be granted pre-judgment and post-judgment interest on the damages caused to it by reason of Defendants Infortrend, Boost and Storageflex's infringement of the '147 Patent, including pre-judgment and post-judgment interest on any enhanced damages or attorneys' fees award;

- K. That each of the Defendants has infringed the '041 Patent;
- L. That such infringement of the '041 Patent by Defendants Aberdeen, Boost, iXsystems and Storageflex has been willful;
- M. That Defendants account for and pay to Crossroads all damages caused by the infringement of the '041 Patent;
- N. That Crossroads receive enhanced damages from Defendants in the form of treble damages, pursuant to 35 U.S.C. § 284 based on each of Defendants Aberdeen's, Boost's, iXsystems' and Storageflex's willful infringement of the '041 Patent;
- O. That Crossroads be granted pre-judgment and post-judgment interest on the damages caused to it by reason of Defendants' infringement of the '041 Patent, including pre-judgment and post-judgment interest on any enhanced damages or attorneys' fees award;
- P. That each of the Defendants has infringed the '040 Patent;
- Q. That such infringement of the '040 Patent by Defendants Aberdeen, Boost, iXsystems and Storageflex has been willful;
- R. That Defendants account for and pay to Crossroads all damages caused by the infringement of the '040 Patent;
- S. That Crossroads receive enhanced damages from Defendants in the form of treble damages, pursuant to 35 U.S.C. § 284 based on each of Defendants Aberdeen's, Boost's, iXsystems' and Storageflex's willful infringement of the '040 Patent;

- T. That Crossroads be granted pre-judgment and post-judgment interest on the damages caused to it by reason of Defendants' infringement of the '040 Patent, including pre-judgment and post-judgment interest on any enhanced damages or attorneys' fees award;
- U. That each of the Defendants has infringed the '311 Patent;
- V. That such infringement of the '311 Patent by Defendants Boost and Storageflex has been willful;
- W. That Defendants account for and pay to Crossroads all damages caused by the infringement of the '311 Patent;
- X. That Crossroads receive enhanced damages from Defendants Boost and Storageflex in the form of treble damages, pursuant to 35 U.S.C. § 284 based on each of Defendants Boost's and Storageflex's willful infringement of the '311 Patent;
- Y. That Crossroads be granted pre-judgment and post-judgment interest on the damages caused to it by reason of Defendants' infringement of the '311 Patent, including pre-judgment and post-judgment interest on any enhanced damages or attorneys' fees award;
- Z. That Defendants pay Crossroads all of Crossroads' reasonable attorneys' fees and expenses;
- AA. That costs be awarded to Crossroads;
- BB. That Defendants, their agents, employees, representatives, successors and assigns, and those acting in privity or in concert with them, be preliminary and permanently enjoined from further infringement of the '035 Patent;

- CC. That Defendants Infortrend, Boost and Storageflex, their agents, employees, representatives, successors and assigns, and those acting in privity or in concert with them, be preliminary and permanently enjoined from further infringement of the '147 Patent;
- DD. That Defendants, their agents, employees, representatives, successors and assigns, and those acting in privity or in concert with them, be preliminary and permanently enjoined from further infringement of the '041 Patent;
- EE. That Defendants, their agents, employees, representatives, successors and assigns, and those acting in privity or in concert with them, be preliminary and permanently enjoined from further infringement of the '040 Patent;
- FF. That Defendants, their agents, employees, representatives, successors and assigns, and those acting in privity or in concert with them, be preliminary and permanently enjoined from further infringement of the '311 Patent;
- GG. That this is an exceptional case under 35 U.S.C. § 285; and
- HH. That Crossroads be granted such other and further relief as the Court may deem just and proper under the circumstances.

DEMAND FOR JURY TRIAL

Crossroads hereby demands a trial by jury on all issues.

Dated: February 1, 2012

Respectfully submitted,

By: /s/ Elizabeth J. Brown Fore
Steven Sprinkle
State Bar No. 00794962
Elizabeth J. Brown Fore
State Bar No. 24001795
Sprinkle IP Law Group, PC

1301 W. 25th Street, Suite 408
Austin, Texas 78705
Tel: (512) 637-9220
Fax: (512) 371-9088
ssprinkle@sprinklelaw.com
ebrownfore@sprinklelaw.com

5. Upon information and belief, Defendant iXsystems, Inc. (“iXsystems”) is a Delaware corporation with a principal place of business of 2490 Kruse Drive, San Jose, CA 95131.

6. Upon information and belief, Defendant Storageflex, Inc. (“Storageflex”) is an Ontario corporation with a principal place of business of 3601 Highway 7, Suite 400, Markham, Ontario L3R 0M3 Canada.

JURISDICTION AND VENUE

7. This action arises under the laws of the United States, more specifically under 35 U.S.C. § 100, *et seq.* Subject matter jurisdiction is proper in this Court pursuant to 28 U.S.C. §§ 1331 and 1338.

8. Personal jurisdiction and venue are proper in this district under 28 U.S.C. §§ 1391(c) and 1400. Upon information and belief, each Defendant has established minimum contacts with this forum such that the exercise of jurisdiction over each defendant would not offend traditional notions of fair play and substantial justice.

9. This Court has personal jurisdiction over Infortrend. Upon information and belief, Infortrend regularly conducts business in the State of Texas and in this judicial district and is subject to the jurisdiction of this Court. Upon information and belief, Infortrend has been doing business in Texas and this judicial district by distributing, marketing, selling and/or offering for sale its products, including, but not limited to, products that practice the subject matter claimed in the Patents-In-Suit, and/or regularly doing or soliciting business and/or engaging in other persistent courses of conduct in and/or directed to Texas and this judicial district.

10. This Court has personal jurisdiction over Aberdeen. Upon information and belief, Aberdeen regularly conducts business in the State of Texas and in this judicial district and is

subject to the jurisdiction of this Court. Upon information and belief, Aberdeen has been doing business in Texas and this judicial district by distributing, marketing, selling and/or offering for sale its products, and/or regularly doing or soliciting business and/or engaging in other persistent courses of conduct in and/or directed to Texas and this judicial district.

11. This Court has personal jurisdiction over Boost. Upon information and belief, Boost regularly conducts business in the State of Texas and in this judicial district and is subject to the jurisdiction of this Court. Upon information and belief, Boost has been doing business in Texas and this judicial district by distributing, marketing, selling and/or offering for sale its products, and/or regularly doing or soliciting business and/or engaging in other persistent courses of conduct in and/or directed to Texas and this judicial district.

12. This Court has personal jurisdiction over iXsystems. Upon information and belief, iXsystems regularly conducts business in the State of Texas and in this judicial district and is subject to the jurisdiction of this Court. Upon information and belief, iXsystems has been doing business in Texas and this judicial district by distributing, marketing, selling and/or offering for sale its products, and/or regularly doing or soliciting business and/or engaging in other persistent courses of conduct in and/or directed to Texas and this judicial district.

13. This Court has personal jurisdiction over Storageflex. Upon information and belief, Storageflex regularly conducts business in the State of Texas and in this judicial district and is subject to the jurisdiction of this Court. Upon information and belief, Storageflex has been doing business in Texas and this judicial district by distributing, marketing, selling and/or offering for sale its products, and/or regularly doing or soliciting business and/or engaging in other persistent courses of conduct in and/or directed to Texas and this judicial district. Further, Storageflex has engaged in activities in this judicial district relating to one or more products that

practice the subject matter claimed by at least one of the Patents-In-Suit by purchasing one or more products from this judicial district that were marked with at least one of the patents-in-suit.

COUNT 1: INFRINGEMENT OF U.S. PATENT NO. 6,425,035

14. Crossroads incorporates by reference the allegations set forth in the preceding paragraphs.

15. On July 23, 2002, United States Patent No. 6,425,035 (the "'035 Patent") was duly and legally issued. A true and correct copy of the '035 Patent is attached hereto as Exhibit A. Crossroads is the assignee and the owner of all right, title, and interest in and to the '035 Patent. The '035 Patent is entitled to a presumption of validity.

16. Defendants Infortrend, Aberdeen, Boost, iXsystems and Storageflex have each directly infringed the '035 Patent. On information and belief, each Defendant continues to directly infringe the '035 Patent.

17. Specifically, each of the Defendants has directly infringed the '035 Patent by making, using, offering for sale, selling and/or importing into the United States certain of their products including at least the following: EonStor RAID Systems with Fibre Host Interface and/or iSCSI Host Interface, EonStor DS RAID Systems with Fibre Host Interface and/or iSCSI Host Interface, ESVA iSCSI Host Series and ESVA Fibre Host Series (Infortrend); XDAS D-Series RAID Systems with FC and/or iSCSI Host, XDAS iSCSI Series RAID Systems, XDAS F8 Series RAID Systems and Aberdeen P8 XDAS with Fibre Host Interface (Aberdeen); EonStor RAID Systems with Fibre Host Interface and/or iSCSI Host Interface, EonStor DS RAID Systems with Fibre Host Interface and/or iSCSI Host Interface, ESVA iSCSI Host Series and ESVA Fibre Host Series (Boost); Titan 316F, Titan 424F, ESVA iSCSI Host Series, and

ESVA Fibre Host Series (iXsystems); and FF1124 and HA3969 with FC or iSCSI Host Interfaces (Storageflex).

18. Further, Defendant Infortrend has been and now is indirectly infringing the '035 Patent, with knowledge of the patent and knowledge that its induced acts constitute patent infringement, by way of actively inducing infringement and/or contributing to the infringement of the '035 Patent by users of Defendant Infortrend's products, such as EonStor RAID Systems with Fibre Host Interface and/or iSCSI Host Interface, EonStor DS RAID Systems with Fibre Host Interface and/or iSCSI Host Interface, ESVA iSCSI Host Series and ESVA Fibre Host Series, by among other things, making, using, offering for sale, selling, importing into the United States, marketing, supporting, promoting, providing product instruction, and/or advertising certain of Defendant Infortrend's products and/or Defendant Infortrend's components for use with same, including EonStor RAID Systems with Fibre Host Interface and/or iSCSI Host Interface, EonStor DS RAID Systems with Fibre Host Interface and/or iSCSI Host Interface, ESVA iSCSI Host Series and ESVA Fibre Host Series and/or components for use with same.

19. Further, Defendant Aberdeen has been and now is indirectly infringing the '035 Patent, with knowledge of the patent and knowledge that its induced acts constitute patent infringement, by way of actively inducing infringement and/or contributing to the infringement of the '035 Patent by users of Defendant Aberdeen's products, such as XDAS D-Series RAID Systems with FC and/or iSCSI Host, XDAS iSCSI Series RAID Systems, XDAS F8 Series RAID Systems and Aberdeen P8 XDAS with Fibre Host Interface by among other things, making, using, offering for sale, selling, importing into the United States, marketing, supporting, providing product instruction, and/or advertising certain of Defendant Aberdeen's products, including XDAS D-Series RAID Systems with FC and/or iSCSI Host, XDAS iSCSI Series

RAID Systems, XDAS F8 Series RAID Systems and Aberdeen P8 XDAS with Fibre Host Interface.

20. Further, Defendant Boost has been and now is indirectly infringing the '035 Patent, with knowledge of the patent and knowledge that its induced acts constitute patent infringement, by way of actively inducing infringement and/or contributing to the infringement of the '035 Patent by users of Defendant Boost's products, such as EonStor RAID Systems with Fibre Host Interface and/or iSCSI Host Interface, EonStor DS RAID Systems with Fibre Host Interface and/or iSCSI Host Interface, ESVA iSCSI Host Series, and ESVA Fibre Host Series by among other things, making, using, offering for sale, selling, importing into the United States, marketing, supporting, providing product instruction, and/or advertising certain of Defendant Boost's products, including the EonStor RAID Systems with Fibre Host Interface and/or iSCSI Host Interface, EonStor DS RAID Systems with Fibre Host Interface and/or iSCSI Host Interface, ESVA iSCSI Host Series, and ESVA Fibre Host Series.

21. Further, Defendant iXsystems has been and now is indirectly infringing the '035 Patent, with knowledge of the patent, by way of contributing to the infringement of the '035 Patent by users of Defendant iXsystems' products, such as the Titan 316F, Titan 424F, ESVA iSCSI Host Series and ESVA Fibre Host Series, by among other things, offering for sale, selling, and/or importing into the United States certain of Defendant iXsystems' products, including Titan 316F, Titan 424F, ESVA iSCSI Host Series, and/or ESVA Fibre Host Series.

22. Further, Defendant Storageflex has been and now is indirectly infringing the '035 Patent, with knowledge of the patent and knowledge that its induced acts constitute patent infringement, by way of actively inducing infringement and/or contributing to the infringement of the '035 Patent by users of Defendant Storageflex's products, such as the FF1124 and

HA3969 with FC or iSCSI Host Interfaces, by among other things, making, using, offering for sale, selling, importing into the United States, marketing, supporting, promoting, providing product instruction, and/or advertising certain of Defendant Storageflex's products and/or components for use with same, including the FF1124 and HA3969 with FC or iSCSI Host Interfaces and/or components for use with same.

23. Each Defendant has been on notice of the '035 Patent since before this lawsuit through prior involvement in litigation involving the '035 Patent (Infortrend), the purchase of a marked product (Storageflex) and/or through notification by letter that its products, including but not limited to the infringing products listed herein, have infringed and continue to infringe (Storageflex, Aberdeen, iXsystems, Boost), and no Defendant has ceased its infringing activities. The infringement of the '035 Patent by each Defendant has been and continues to be willful and deliberate.

24. Crossroads has been irreparably harmed by each of Defendant Infortrend's, Storageflex's, Aberdeen's, Boost's and iXsystems' acts of infringement of the '035 Patent, and will continue to be harmed unless and until each of Defendant Infortrend's, Storageflex's, Aberdeen's, Boost's and iXsystems' acts of infringement are enjoined and restrained by order of this Court.

25. As a result of the acts of infringement of the '035 Patent by Defendants, Crossroads has suffered and will continue to suffer damages in an amount to be proven at trial.

COUNT 2: INFRINGEMENT OF U.S. PATENT NO. 7,051,147

26. Crossroads incorporates by reference the allegations set forth in the preceding paragraphs.

27. On May 23, 2006, United States Patent No. 7,051,147 (the "'147 Patent") was duly and legally issued. A true and correct copy of the '147 Patent is attached hereto as Exhibit B. Crossroads is the assignee and the owner of all right, title, and interest in and to the '147 Patent. The '147 Patent is entitled to a presumption of validity.

28. Defendants Infortrend, Boost and Storageflex have directly infringed the '147 Patent and, on information and belief, Defendants Infortrend, Boost and Storageflex continue to directly infringe the '147 Patent.

29. Specifically, Defendants Infortrend, Boost and Storageflex have directly infringed the '147 Patent by making, using, offering for sale, selling and/or importing into the United States certain of their products including at least the following: EonStor Fibre-to-Fibre RAID Systems and EonStor DS Fibre-to-Fibre RAID Systems (Infortrend); EonStor Fibre-to-Fibre RAID Systems (Boost); and FF1124 (Storageflex).

30. Further, Defendant Infortrend has been and now is indirectly infringing the '147 Patent, with knowledge of the patent and knowledge that its induced acts constitute patent infringement, by way of actively inducing infringement and/or contributing to the infringement of the '147 Patent by users of Defendant Infortrend's products, such as EonStor Fibre-to-Fibre RAID Systems and EonStor DS Fibre-to-Fibre RAID Systems by, among other things, making, using, offering for sale, selling, importing into the United States, marketing, supporting, promoting, providing product instruction, and/or advertising certain of its products and/or Defendant Infortrend's components for use with same, including EonStor Fibre-to-Fibre RAID Systems, EonStor DS Fibre-to-Fibre RAID Systems and/or components for use with same.

31. Further, Defendant Boost has been and now is indirectly infringing the '147 Patent, with knowledge of the patent and knowledge that its induced acts constitute patent

UNITED STATES PATENT AND TRADEMARK OFFICE
CERTIFICATE OF CORRECTION

PATENT NO. : 7,934,041 B2
APPLICATION NO. : 12/690592
DATED : April 26, 2011
INVENTOR(S) : Geoffrey B. Hoese et al.

Page 1 of 1

It is certified that error appears in the above-identified patent and that said Letters Patent is hereby corrected as shown below:

Claim 20: Col. 10 line 56 should read -

A set of devices connected --to-- a first transport medium, wherein the first transport medium --is a serial transport medium--;

Signed and Sealed this
Thirteenth Day of September, 2011

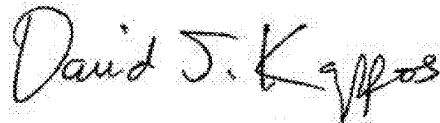

David J. Kappos
Director of the United States Patent and Trademark Office

SPE RESPONSE FOR CERTIFICATE OF CORRECTION

DATE : 7/19/2011

TO SPE OF : ART UNIT 2181

SUBJECT : Request for Certificate of Correction for Appl. No.: 12/690592 Patent No.: 7934041 B2

CofC mailroom date: 7/11/2011

Please respond to this request for a certificate of correction within 7 days.

FOR IFW FILES:

Please review the requested changes/corrections as shown in the **COCIN** document(s) in the IFW application image. No new matter should be introduced, nor should the scope or meaning of the claims be changed.

Please complete the response (see below) and forward the completed response to scanning using document code **COCX**.

FOR PAPER FILES:

Please review the requested changes/corrections as shown in the attached certificate of correction. Please complete this form (see below) and forward it with the file to:

**Certificates of Correction Branch (CofC)
Randolph Square – 9D10-A
Palm Location 7580**

Note: _____

Virginia Tolbert

**Certificates of Correction Branch
(571) 272-0460**

Thank You For Your Assistance

The request for issuing the above-identified correction(s) is hereby:

Note your decision on the appropriate box.

Approved

All changes apply.

Approved in Part

Specify below which changes **do not** apply.

Denied

State the reasons for denial below.

Comments: _____

Robert W. Kent 2181
SPE Art Unit

SPE RESPONSE FOR CERTIFICATE OF CORRECTION

DATE : 7/19/2011
TO SPE OF : ART UNIT 2181
SUBJECT : Request for Certificate of Correction for Appl. No.: 12/690592 Patent No.: 7934041 B2
CofC mailroom date: 7/11/2011

Please respond to this request for a certificate of correction within 7 days.

FOR IFW FILES:

Please review the requested changes/corrections as shown in the **COCIN** document(s) in the IFW application image. No new matter should be introduced, nor should the scope or meaning of the claims be changed.

Please complete the response (see below) and forward the completed response to scanning using document code **COCX**.

FOR PAPER FILES:

Please review the requested changes/corrections as shown in the attached certificate of correction. Please complete this form (see below) and forward it with the file to:

**Certificates of Correction Branch (CofC)
Randolph Square – 9D10-A
Palm Location 7580**

Note: _____

Virginia Tolbert
Certificates of Correction Branch
(571) 272-0460

Thank You For Your Assistance

The request for issuing the above-identified correction(s) is hereby:
Note your decision on the appropriate box.

- | | |
|--------------------------------------------------|--------------------------------------------------|
| <input type="checkbox"/> Approved | All changes apply. |
| <input type="checkbox"/> Approved in Part | Specify below which changes do not apply. |
| <input type="checkbox"/> Denied | State the reasons for denial below. |

Comments: _____

SPE **Art Unit**

UNITED STATES PATENT AND TRADEMARK OFFICE

CERTIFICATE OF CORRECTION

Page 1 of 1

PATENT NO. **7,934,041**

APPLICATION NO.: **12/690,592**

ISSUE DATE: **04/26/2011**

INVENTOR(S): **Geoffrey B. Hoese, et al.**

It is certified that an error appears or errors appear in the above-identified patent and that said Letters Patent is hereby corrected as shown below:

Claim 20:

A set of devices connected --to-- a first transport medium, wherein the first transport medium --is a serial transport medium--;

MAILING ADDRESS OF SENDER:

Customer No. 44654
Sprinkle IP Law Group
1301 W. 25th Street, Suite 408
Austin, Texas 78705
Tel. (512) 637-9220
Fax. (512) 371-9088

This form is estimated to take 1.0 hour to complete. Time will vary depending upon the needs of the individual case. Any comment on the amount of time you are required to complete this form should be sent to the Chief Information Officer, U.S. Patent and Trademark Office, Washington, D.C. 20231. DO NOT SEND FEES OR COMPLETED FORMS TO THIS ADDRESS. SEND TO: Assistant Commissioner for Patents, Washington, D.C. 20231

Electronic Patent Application Fee Transmittal

Application Number:	12690592			
Filing Date:	20-Jan-2010			
Title of Invention:	STORAGE ROUTER AND METHOD FOR PROVIDING VIRTUAL LOCAL STORAGE			
First Named Inventor/Applicant Name:	Geoffrey B. Hoese			
Filer:	John L. Adair/Janice Pampell			
Attorney Docket Number:	CROSS1120-33			
Filed as Large Entity				
Utility under 35 USC 111 (a) Filing Fees				
Description	Fee Code	Quantity	Amount	Sub-Total in USD(\$)
Basic Filing:				
Pages:				
Claims:				
Miscellaneous-Filing:				
Petition:				
Patent-Appeals-and-Interference:				
Post-Allowance-and-Post-Issuance:				
Certificate of correction	1811	1	100	100
Extension-of-Time:				

Description	Fee Code	Quantity	Amount	Sub-Total in USD(\$)
Miscellaneous:				
Total in USD (\$)				100

Electronic Acknowledgement Receipt

EFS ID:	10490129
Application Number:	12690592
International Application Number:	
Confirmation Number:	8115
Title of Invention:	STORAGE ROUTER AND METHOD FOR PROVIDING VIRTUAL LOCAL STORAGE
First Named Inventor/Applicant Name:	Geoffrey B. Hoese
Customer Number:	44654
Filer:	John L. Adair/Janice Pampell
Filer Authorized By:	John L. Adair
Attorney Docket Number:	CROSS1120-33
Receipt Date:	11-JUL-2011
Filing Date:	20-JAN-2010
Time Stamp:	15:20:53
Application Type:	Utility under 35 USC 111(a)

Payment information:

Submitted with Payment	yes
Payment Type	Deposit Account
Payment was successfully received in RAM	\$ 100
RAM confirmation Number	1837
Deposit Account	503183
Authorized User	

The Director of the USPTO is hereby authorized to charge indicated fees and credit any overpayment as follows:

Charge any Additional Fees required under 37 C.F.R. Section 1.20 (Post Issuance fees)

Charge any Additional Fees required under 37 C.F.R. Section 1.21 (Miscellaneous fees and charges)

File Listing:					
Document Number	Document Description	File Name	File Size(Bytes)/ Message Digest	Multi Part /.zip	Pages (if appl.)
1	Miscellaneous Incoming Letter	CROSS1120-33_Transmittal_Letter.pdf	34484 225180843b7e705f6c5ae82d25f3193d2f695d6d	no	1
Warnings:					
Information:					
2	Request for Certificate of Correction	CROSS1120-33_Certificate_of_Correction.pdf	31604 39defa7b887e73ea1a92b03836649154ba03765	no	1
Warnings:					
Information:					
3	Fee Worksheet (SB06)	fee-info.pdf	30191 d67fb2524c07864b91d8088e775d1e1c54d8dc	no	2
Warnings:					
Information:					
Total Files Size (in bytes):			96279		
<p>This Acknowledgement Receipt evidences receipt on the noted date by the USPTO of the indicated documents, characterized by the applicant, and including page counts, where applicable. It serves as evidence of receipt similar to a Post Card, as described in MPEP 503.</p> <p><u>New Applications Under 35 U.S.C. 111</u> If a new application is being filed and the application includes the necessary components for a filing date (see 37 CFR 1.53(b)-(d) and MPEP 506), a Filing Receipt (37 CFR 1.54) will be issued in due course and the date shown on this Acknowledgement Receipt will establish the filing date of the application.</p> <p><u>National Stage of an International Application under 35 U.S.C. 371</u> If a timely submission to enter the national stage of an international application is compliant with the conditions of 35 U.S.C. 371 and other applicable requirements a Form PCT/DO/EO/903 indicating acceptance of the application as a national stage submission under 35 U.S.C. 371 will be issued in addition to the Filing Receipt, in due course.</p> <p><u>New International Application Filed with the USPTO as a Receiving Office</u> If a new international application is being filed and the international application includes the necessary components for an international filing date (see PCT Article 11 and MPEP 1810), a Notification of the International Application Number and of the International Filing Date (Form PCT/RO/105) will be issued in due course, subject to prescriptions concerning national security, and the date shown on this Acknowledgement Receipt will establish the international filing date of the application.</p>					

IN THE UNITED STATES PATENT AND TRADEMARK OFFICE	
TRANSMITTAL LETTER	Atty. Docket No. CROSS1120-33
Applicant Geoffrey B. Hoese, et al.	
Application No. 12/690,592	Filing Date 01/20/2010
Patent Number 7,934,041	Issue Date 04/26/2011
For Storage Router and Method for Providing Virtual Local Storage	
Confirmation No. 8115	

Attention: Certificate of Correction Branch
Office of Patent Publication
Commissioner for Patents
P.O. Box 1450
Alexandria, VA 22313-1450

Dear Sir:

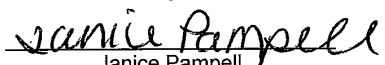
<u>Certificate of Mailing Under 37 C.F.R. 1.8</u>
I hereby certify that this correspondence is being deposited with the U.S. Patent Office using the United States Patent and Trademark Office's EFS-Web system on <u>7-11-11</u>
 Janice Pampell

Transmitted herewith for filing in the above-identified Patent is a Certificate of Correction. The error noted on the Certificate of Correction is on the part of the Applicant. The Commissioner is hereby authorized to charge the appropriate fee against Deposit Account No. 50-3183 of Sprinkle IP Law Group.

Respectfully submitted,

SPRINKLE IP LAW GROUP

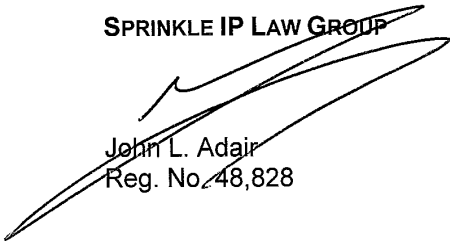
John L. Adair
Reg. No. 48,828

Date: 7-8, 2011

Sprinkle IP Law Group
1301 W. 25th Street
Suite 408
Austin, Texas 78705
Tel. (512) 637-9225
Fax. (512) 371-9088



UNITED STATES PATENT AND TRADEMARK OFFICE

UNITED STATES DEPARTMENT OF COMMERCE
United States Patent and Trademark Office
Address: COMMISSIONER FOR PATENTS
P.O. Box 1450
Alexandria, Virginia 22313-1450
www.uspto.gov

Table with 5 columns: APPLICATION NO., ISSUE DATE, PATENT NO., ATTORNEY DOCKET NO., CONFIRMATION NO.
Row 1: 12/690,592, 04/26/2011, 7934041, CROSS1120-33, 8115

44654 7590 04/06/2011
Sprinkle IP Law Group
1301 W. 25th Street
Suite 408
Austin, TX 78705

ISSUE NOTIFICATION

The projected patent number and issue date are specified above.

Determination of Patent Term Adjustment under 35 U.S.C. 154 (b)
(application filed on or after May 29, 2000)

The Patent Term Adjustment is 0 day(s). Any patent to issue from the above-identified application will include an indication of the adjustment on the front page.

If a Continued Prosecution Application (CPA) was filed in the above-identified application, the filing date that determines Patent Term Adjustment is the filing date of the most recent CPA.

Applicant will be able to obtain more detailed information by accessing the Patent Application Information Retrieval (PAIR) WEB site (http://pair.uspto.gov).

Any questions regarding the Patent Term Extension or Adjustment determination should be directed to the Office of Patent Legal Administration at (571)-272-7702. Questions relating to issue and publication fee payments should be directed to the Application Assistance Unit (AAU) of the Office of Data Management (ODM) at (571)-272-4200.

APPLICANT(s) (Please see PAIR WEB site http://pair.uspto.gov for additional applicants):

Geoffrey B. Hoese, Austin, TX;
Jeffry T. Russell, Cibolo, TX;



UNITED STATES PATENT AND TRADEMARK OFFICE

UNITED STATES DEPARTMENT OF COMMERCE
United States Patent and Trademark Office
Address: COMMISSIONER FOR PATENTS
P.O. Box 1450
Alexandria, Virginia 22313-1450
www.uspto.gov

APPLICATION NO.	FILING DATE	FIRST NAMED INVENTOR	ATTORNEY DOCKET NO.	CONFIRMATION NO.
12/690,592	01/20/2010	Geoffrey B. Hoese	CROSS1120-33	8115
44654	7590	03/23/2011	EXAMINER	
Sprinkle IP Law Group 1301 W. 25th Street Suite 408 Austin, TX 78705			SHIN, CHRISTOPHER B	
			ART UNIT	PAPER NUMBER
			2181	
			MAIL DATE	DELIVERY MODE
			03/23/2011	PAPER

Please find below and/or attached an Office communication concerning this application or proceeding.

The time period for reply, if any, is set in the attached communication.

Response to Rule 312 Communication	Application No.	Applicant(s)
	12/690,592	HOESE ET AL.
	Examiner	Art Unit

-- The MAILING DATE of this communication appears on the cover sheet with the correspondence address --

1. The amendment filed on 21 March 2011 under 37 CFR 1.312 has been considered, and has been:
- a) entered.
 - b) entered as directed to matters of form not affecting the scope of the invention.
 - c) disapproved because the amendment was filed after the payment of the issue fee.
Any amendment filed after the date the issue fee is paid must be accompanied by a petition under 37 CFR 1.313(c)(1) and the required fee to withdraw the application from issue.
 - d) disapproved. See explanation below.
 - e) entered in part. See explanation below.

Timothy Caldwell
Publishing Division

PART B - FEE(S) TRANSMITTAL

Complete and send this form, together with applicable fee(s), to: **Mail Stop ISSUE FEE
Commissioner for Patents
P.O. Box 1450
Alexandria, Virginia 22313-1450**
or **Fax (571)-273-2885**

INSTRUCTIONS: This form should be used for transmitting the ISSUE FEE and PUBLICATION FEE (if required). Blocks 1 through 5 should be completed where appropriate. All further correspondence including the Patent, advance orders and notification of maintenance fees will be mailed to the current correspondence address as indicated unless corrected below or directed otherwise in Block 1, by (a) specifying a new correspondence address; and/or (b) indicating a separate "FEE ADDRESS" for maintenance fee notifications.

CURRENT CORRESPONDENCE ADDRESS (Note: Use Block 1 for any change of address)

44654 7590 01/10/2011
Sprinkle IP Law Group
1301 W. 25th Street
Site 408
Austin, TX 78705

Note: A certificate of mailing can only be used for domestic mailings of the Fee(s) Transmittal. This certificate cannot be used for any other accompanying papers. Each additional paper, such as an assignment or formal drawing, must have its own certificate of mailing or transmission.

Certificate of Mailing or Transmission

I hereby certify that this Fee(s) Transmittal is being deposited with the United States Postal Service with sufficient postage for first class mail in an envelope addressed to the Mail Stop ISSUE FEE address above, or being facsimile transmitted to the USPTO (571) 273-2885, on the date indicated below.

Janice Pampell	(Depositor's name)
<i>Janice Pampell</i>	(Signature)
March 21, 2011	(Date)

APPLICATION NO.	FILING DATE	FIRST NAMED INVENTOR	ATTORNEY DOCKET NO.	CONFIRMATION NO.
12/690,592	01/20/2010	Geoffrey B. Hoese	CROSS1120-33	8115

TITLE OF INVENTION: STORAGE ROUTER AND METHOD FOR PROVIDING VIRTUAL LOCAL STORAGE

APPLN. TYPE	SMALL ENTITY	ISSUE FEE DUE	PUBLICATION FEE DUE	PREV. PAID ISSUE FEE	TOTAL FEE(S) DUE	DATE DUE
nonprovisional	NO	\$1510	\$300	\$0	\$1810	04/11/2011

EXAMINER	ART UNIT	CLASS-SUBCLASS
SHIN, CHRISTOPHER B	2181	710-305000

1. Change of correspondence address or indication of "Fee Address" (37 CFR 1.363).
- Change of correspondence address (or Change of Correspondence Address form PTO/SB/122) attached.
 - "Fee Address" indication (or "Fee Address" Indication form PTO/SB/47; Rev 03-02 or more recent) attached. **Use of a Customer Number is required.**
2. For printing on the patent front page, list
- (1) the names of up to 3 registered patent attorneys or agents OR, alternatively,
 - (2) the name of a single firm (having as a member a registered attorney or agent) and the names of up to 2 registered patent attorneys or agents. If no name is listed, no name will be printed.
- 1 Sprinkle IP Law
2 Group
3

3. ASSIGNEE NAME AND RESIDENCE DATA TO BE PRINTED ON THE PATENT (print or type)

PLEASE NOTE: Unless an assignee is identified below, no assignee data will appear on the patent. If an assignee is identified below, the document has been filed for recordation as set forth in 37 CFR 3.11. Completion of this form is NOT a substitute for filing an assignment.

(A) NAME OF ASSIGNEE

(B) RESIDENCE: (CITY and STATE OR COUNTRY)

Crossroads Systems, Inc.

Austin, TX

Please check the appropriate assignee category or categories (will not be printed on the patent): Individual Corporation or other private group entity Government

4a. The following fee(s) are submitted:

- Issue Fee
- Publication Fee (No small entity discount permitted)
- Advance Order - # of Copies _____

4b. Payment of Fee(s): (Please first reapply any previously paid issue fee shown above)

- A check is enclosed.
- Payment by credit card. Form PTO-2038 is attached.
- The Director is hereby authorized to charge the required fee(s), any deficiency, or credit any overpayment, to Deposit Account Number 50-3183 (enclose an extra copy of this form).

5. Change in Entity Status (from status indicated above)

- a. Applicant claims SMALL ENTITY status. See 37 CFR 1.27.
- b. Applicant is no longer claiming SMALL ENTITY status. See 37 CFR 1.27(g)(2).

NOTE: The Issue Fee and Publication Fee (if required) will not be accepted from anyone other than the applicant; a registered attorney or agent; or the assignee or other party in interest as shown by the records of the United States Patent and Trademark Office.

Authorized Signature _____

Date 3/21/11

Typed or printed name Ari G. Akmal

Registration No. 51,388

This collection of information is required by 37 CFR 1.311. The information is required to obtain or retain a benefit by the public which is to file (and by the USPTO to process) an application. Confidentiality is governed by 35 U.S.C. 122 and 37 CFR 1.14. This collection is estimated to take 12 minutes to complete, including gathering, preparing, and submitting the completed application form to the USPTO. Time will vary depending upon the individual case. Any comments on the amount of time you require to complete this form and/or suggestions for reducing this burden, should be sent to the Chief Information Officer, U.S. Patent and Trademark Office, U.S. Department of Commerce, P.O. Box 1450, Alexandria, Virginia 22313-1450. DO NOT SEND FEES OR COMPLETED FORMS TO THIS ADDRESS. SEND TO: Commissioner for Patents, P.O. Box 1450, Alexandria, Virginia 22313-1450.

Under the Paperwork Reduction Act of 1995, no persons are required to respond to a collection of information unless it displays a valid OMB control number.

IN THE UNITED STATES PATENT AND TRADEMARK OFFICE	
AMENDMENT UNDER 37 CFR 1.312	Atty. Docket No. (Opt.) CROSS1120-33
Applicants: Geoffrey B. Hoese	
Application Number 12/690,592	Filed 01/20/2010
For: Storage Router and Method for Providing Virtual Local Storage	
Group Art Unit 2181	Confirmation Number: 8115

Mail Stop: Issue Fee

Commissioner for Patents
P.O. Box 1450
Alexandria, VA 22313

Dear Sir:

<u>Certification Under 37 C.F.R. §1.10</u>
I hereby certify that this correspondence is being deposited electronically with the U.S. Patent and Trademark Office using the United States Patent and Trademark Office's EFS-Web system on <u>3/2/11</u>
 Janice Pampell

A Notice of Allowance and Fee(s) Due was issued by the Examiner on January 10, 2011. The Applicant therefore respectfully requests that the Examiner enter the following amendment under 37 CFR 1.312. While Applicant understands that entry of an Amendment after the notice of allowance is a matter of discretion and not of right, Applicant respectfully requests that the Examiner consider and enter the following changes to the specification.

Please amend the application as follows:

IN THE SPECIFICATION

Following the title, please replace the first paragraph of page one the following paragraph:

[0001] [0001] This application is a continuation of, and claims a benefit of priority under 35 U.S.C. 120 of the filing date of U.S. Patent Application Serial No. 12/552,885 entitled "Storage Router and Method for Providing Virtual Local Storage" filed 09/02/2009, which is a continuation of and claims the benefit of priority of U.S. Application Serial No. 11/851,724 entitled "Storage Router and Method for Providing Virtual Local Storage" filed 09/07/2007, now U.S. Patent No. 7,689,754 issued 03/30/2010, which is a continuation of and claims the benefit of priority of U.S. Patent Application Serial No. 11/442,878 entitled "Storage Router and Method for Providing Virtual Local Storage" filed 05/30/2006, now abandoned, which is a continuation of and claims the benefit of priority of U.S. Patent Application Serial No. 11/353,826 entitled "Storage Router and Method for Providing Virtual Local Storage" filed on 02/14/2006, now U.S. Patent No. 7,340,549 issued 03/04/2008, which is a continuation of and claims the benefit of priority of U.S. Patent Application Serial No. 10/658,163 entitled "Storage Router and Method for Providing Virtual Local Storage" filed on 09/09/2003 now U.S. Patent No. 7,051,147 issued 05/23/2006, which is a continuation of and claims the benefit of benefit of priority of U.S. Patent Application Serial No. 10/081,110 by inventors Geoffrey B. Hoese and Jeffery T. Russell, entitled "Storage Router and Method for Providing Virtual Local Storage" filed on 02/22/2002, now U.S. Patent No. 6,789,152 issued on 09/07/2004, which in turn is a continuation of and claims benefit of priority of U.S. Application No. 09/354,682 by inventors Geoffrey B. Hoese and Jeffrey T. Russell, entitled "Storage Router and Method for Providing Virtual Local Storage" filed on 07/15/1999, now U.S. Patent No. 6,421,753 issued on 07/16/2002, which in turn is a continuation of and claims benefit of priority of U.S. Patent Application Serial No. 09/001,799, filed on 12/31/1997, now U.S. Patent No. 5,941,972 issued on 08/24/1999, and hereby incorporates these applications and patents by reference in their entireties as if they had been fully set forth herein.

REMARKS

Applicants appreciate the time taken by the Examiner to review the present amendment.

Applicant submits that the priority information in the new paragraph above was recognized by the United States Patent and Trademark office as shown by its inclusion in the official filing receipt. It is respectfully submitted that the amendment does not affect the merits of the application and is proper subject matter for an Amendment Under 37 CFR 1.312. The Applicant therefore respectfully requests entry of the amendment.

The Commissioner is hereby authorized to charge any deficiencies or credit any overpayment to Deposit Account No. 50-3183.

Respectfully submitted,

Sprinkle IP Law Group

Ari G. Akmal
Reg. No. 51,388

Dated: March 21, 2011

1301 W. 25th Street, Suite 408
Austin, Texas 78705
Tel. 512-637-9220
Fax. 512-371-9088

Electronic Patent Application Fee Transmittal

Application Number:	12690592			
Filing Date:	20-Jan-2010			
Title of Invention:	STORAGE ROUTER AND METHOD FOR PROVIDING VIRTUAL LOCAL STORAGE			
First Named Inventor/Applicant Name:	Geoffrey B. Hoese			
Filer:	Ari G. Akmal/Janice Pampell			
Attorney Docket Number:	CROSS1120-33			
Filed as Large Entity				
Utility under 35 USC 111 (a) Filing Fees				
Description	Fee Code	Quantity	Amount	Sub-Total in USD(\$)
Basic Filing:				
Pages:				
Claims:				
Miscellaneous-Filing:				
Petition:				
Patent-Appeals-and-Interference:				
Post-Allowance-and-Post-Issuance:				
Utility Appl issue fee	1501	1	1510	1510
Publ. Fee- early, voluntary, or normal	1504	1	300	300

Description	Fee Code	Quantity	Amount	Sub-Total in USD(\$)
Extension-of-Time:				
Miscellaneous:				
Total in USD (\$)				1810

Electronic Acknowledgement Receipt

EFS ID:	9696893
Application Number:	12690592
International Application Number:	
Confirmation Number:	8115
Title of Invention:	STORAGE ROUTER AND METHOD FOR PROVIDING VIRTUAL LOCAL STORAGE
First Named Inventor/Applicant Name:	Geoffrey B. Hoese
Customer Number:	44654
Filer:	Ari G. Akmal/Janice Pampell
Filer Authorized By:	Ari G. Akmal
Attorney Docket Number:	CROSS1120-33
Receipt Date:	21-MAR-2011
Filing Date:	20-JAN-2010
Time Stamp:	11:47:44
Application Type:	Utility under 35 USC 111(a)

Payment information:

Submitted with Payment	yes
Payment Type	Deposit Account
Payment was successfully received in RAM	\$ 1810
RAM confirmation Number	8781
Deposit Account	503183
Authorized User	

The Director of the USPTO is hereby authorized to charge indicated fees and credit any overpayment as follows:

Charge any Additional Fees required under 37 C.F.R. Section 1.19 (Document supply fees)

Charge any Additional Fees required under 37 C.F.R. Section 1.20 (Post Issuance fees)

Charge any Additional Fees required under 37 C.F.R. Section 1.21 (Miscellaneous fees and charges)

File Listing:

Document Number	Document Description	File Name	File Size(Bytes)/ Message Digest	Multi Part /.zip	Pages (if appl.)
1	Miscellaneous Incoming Letter	CROSS1120-33_Transmittal_of_Payment_of_Issue_Fee.pdf	38692 0ed3d30a44ed45ee1cf37580d97b0bbad11eb3ba	no	1

Warnings:

Information:

2	Issue Fee Payment (PTO-85B)	CROSS1120-33_PTOL-85.pdf	96691 2081e8bd4fd0c06c1b420644747322b881b52ec5	no	1
---	-----------------------------	--------------------------	---------------------------------------------------	----	---

Warnings:

Information:

3	Amendment after Notice of Allowance (Rule 312)	CROSS1120-33_Amendment_Under_312.pdf	104947 3146295b48db3e23309885ba8408b8a8c7cd713	no	3
---	------------------------------------------------	--------------------------------------	---------------------------------------------------	----	---

Warnings:

Information:

4	Fee Worksheet (PTO-875)	fee-info.pdf	31982 35c157186b5d2bc9d857dba7280faf1357b9fdc8	no	2
---	-------------------------	--------------	---------------------------------------------------	----	---

Warnings:

Information:

Total Files Size (in bytes): 272312

This Acknowledgement Receipt evidences receipt on the noted date by the USPTO of the indicated documents, characterized by the applicant, and including page counts, where applicable. It serves as evidence of receipt similar to a Post Card, as described in MPEP 503.

New Applications Under 35 U.S.C. 111

If a new application is being filed and the application includes the necessary components for a filing date (see 37 CFR 1.53(b)-(d) and MPEP 506), a Filing Receipt (37 CFR 1.54) will be issued in due course and the date shown on this Acknowledgement Receipt will establish the filing date of the application.

National Stage of an International Application under 35 U.S.C. 371

If a timely submission to enter the national stage of an international application is compliant with the conditions of 35 U.S.C. 371 and other applicable requirements a Form PCT/DO/EO/903 indicating acceptance of the application as a national stage submission under 35 U.S.C. 371 will be issued in addition to the Filing Receipt, in due course.

New International Application Filed with the USPTO as a Receiving Office

If a new international application is being filed and the international application includes the necessary components for an international filing date (see PCT Article 11 and MPEP 1810), a Notification of the International Application Number and of the International Filing Date (Form PCT/RO/105) will be issued in due course, subject to prescriptions concerning national security, and the date shown on this Acknowledgement Receipt will establish the international filing date of the application.

TRANSMITTAL OF PAYMENT OF ISSUE FEE (LARGE Entity) 37 C.F.R. 1.311)				Docket No. CROSS1120-33
Applicant(s) Geoffrey B. Hoese				
Application No. 12/690,592	Filing Date 01/20/2010	Examiner SHIN, Christopher B.	Group Art Unit 2181	Confirmation No. 8115
Title: STORAGE ROUTER AND METHOD FOR PROVIDING VIRTUAL LOCAL STORAGE				

**Mail Stop: Issue Fee
Commissioner for Patents
P.O. Box 1450
Alexandria, VA 22313-1450**

Transmitted herewith are the following items in reference to the above-identified application:

- Issue Fee Transmittal Form PTOL-85
- Issue Fee: \$1,510.00
- Publication Fee \$300.00
- Amendment Under 1.312
- The Director is hereby authorized to charge Deposit Account No. 50-3183 of Sprinkle IP Law Group.
- The Director is hereby authorized to charge any deficiencies or credit any overpayments to Deposit Account No. 50-3183 of Sprinkle IP Law Group.

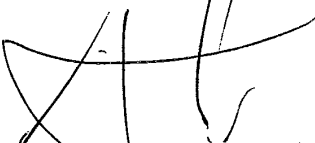

Ari G. Akmal
Reg. No. 48,828

Customer No. 44654
Sprinkle IP Law Group
1301 W. 25th Street, Suite 408
Austin, Texas 78705
Tel. (512) 637-9220
Fax. (512) 371-9088

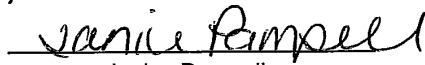
<u>Certificate of Transmission Under 37 C.F.R. § 1.8</u>
I hereby certify that this correspondence is being deposited electronically with the U.S. Patent and Trademark Office using the United States Patent and Trademark Office's EFS-Web system on <u>3/2/11</u>
 _____ Janice Pampell

INFORMATION DISCLOSURE STATEMENT BY APPLICANT				Application Number	12/690,592	
				Filing Date	01/20/2010	
				First Named Inventor	Geoffrey B. Hoes	
				Group Art Unit	2111	
				Examiner Name	Unknown	
Sheet	7	of	9	Attorney Docket Number	CROSS1120-33	
U.S. PATENT DOCUMENTS						
Examiner Initials	Cite No.	Document Number		Publication Date MM-DD-YYYY	Name of Patentee or Applicant of Cited Document	Pages, Columns, Lines Where Relevant Passages or Figures Appear
		Number-Kind Code (if known)				
	A189	6,260,120		7/10/2001	Blumenau, et al.	
	A190	6,268,789		7/31/2001	Diamant, et al.	
	A191	6,308,247		10/23/2001	Ackerman	
	A192	6,330,629		12/11/2001	Kondo, et al.	
	A193	6,330,687		12/11/2001	Griffith	
	A194	6,341,315		1/22/2002	Arroyo, et al.	
	A195	6,343,324		1/29/2002	Hubis, et al.	
	A196	6,363,462		3/26/2002	Bergsten	
	A197	6,401,170		6/4/2002	Griffith, et al.	
	A198	6,421,753		7/16/2002	Hoes, et al.	
	A199	6,425,035		7/23/2002	Hoes, et al.	
	A200	6,425,036		7/23/2002	Hoes, et al.	
	A201	6,425,052		5/23/2002	Hashemi	
	A202	6,453,345		9/17/2002	Trcka, et al.	
	A203	6,484,245		11/19/2002	Sanada, et al.	
	A204	6,529,996		3/4/2003	Nguyen, et al.	
	A205	6,547,576		4/15/2003	Peng, et al.	
	A206	6,560,750		5/6/2003	Chien, et al.	
	A207	6,563,701		5/13/2003	Peng, et al.	
	A208	6,775,693		8/10/2004	Adams	
	A209	6,792,602		9/14/2004	Lin, et al.	
	A210	6,820,212		11/16/2004	Duchesne, et al.	
	A211	6,854,027		2/8/2005	Hsu, et al.	
	A212	6,862,637		3/1/2005	Stupar	
	A213	6,874,043		3/29/2005	Treggiden	
	A214	6,874,100		3/29/2005	Rauscher	
	A215	6,910,083		6/21/2005	Hsu, et al.	
	A216	7,065,076		6/20/2006	Nemazie	
	A217	7,127,668		10/24/2006	McBryde, et al.	
	A218	7,133,965		11/7/2006	Chien	
Examiner Signature	/Christopher Shin/				Date Considered	08/26/2010

Change(s) applied
to document,
/A.E.M./
3/17/2011

ALL REFERENCES CONSIDERED EXCEPT WHERE LINED THROUGH. /C.S./

INFORMATION DISCLOSURE STATEMENT BY APPLICANT				Application Number	12/690,592	
				Filing Date	01/20/2010	
				First Named Inventor	Geoffrey B. Hoese	
				Group Art Unit	2111	
				Examiner Name	Unknown	
Sheet	4	of	9	Attorney Docket Number	CROSS1120-33	
U.S. PATENT DOCUMENTS						
Examiner Initials	Cite No.	Document Number		Publication Date MM-DD-YYYY	Name of Patentee or Applicant of Cited Document	Pages, Columns, Lines Where Relevant Passages or Figures Appear
		Number-Kind Code (if known)				
	A99	5,581,724		12/3/1996	Belsan et al.	
	A100	5,596,562		01/8/21/1997	Chen	
	A101	5,596,736		1/21/1997	Kerns	
	A102	5,598,541		1/28/1997	Malladi	
	A103	5,613,082		3/18/1997	Brewer, et al.	
	A104	5,621,902		4/15/1997	Cases, et al.	
	A105	5,632,012		5/20/1997	Belsan, et al.	
	A106	5,634,111		5/27/1997	Oeda, et al.	
	A107	5,638,518		6/10/1997	Malladi	
	A108	5,642,515		6/24/1997	Jones, et al.	
	A109	5,659,756		8/19/1997	Hefferon, et al.	
	A110	5,664,107		9/2/1997	Chatwanni, et al.	
	A111	5,680,556		10/21/1997	Begun, et al.	
	A112	5,684,800		11/4/1997	Dobbins, et al.	
	A113	5,701,491		12/23/1997	Dunn, et al.	
	A114	5,712,976		1/27/1998	Falcon, et al.	
	A115	5,727,218		3/10/1998	Hotchkin	
	A116	5,729,705		3/17/1998	Weber	
	A117	5,743,847		4/28/1998	Nakamura, et al.	
	A118	5,748,924		5/5/1998	Llorens, et al.	
	A119	5,571,971 5,751,971		5/12/1998	Dobbins, et al.	
	A120	5,751,975		5/12/1998	Gillespie, et al.	
	A121	5,764,931		6/9/1998	Schmahl, et al.	
	A122	5,768,623		6/16/1998	Judd, et al.	
	A123	5,774,683		6/30/1998	Gulick	
	A124	5,778,411		7/7/1998	DeMoss	
	A125	5,781,715		7/14/1998	Sheu	
	A126	5,802,278		9/1/1998	Isfeld, et al.	
	A127	5,805,816		9/8/1998	Picazo, Jr., et al.	
	A128	5,805,920		9/8/1998	Sprenkle, et al.	
Examiner Signature	/Christopher Shin/				Date Considered	08/26/2010

Change(s) applied
to document,
/A.E.M./
3/17/2011

ALL REFERENCES CONSIDERED EXCEPT WHERE LINED THROUGH. /C.S./

INFORMATION DISCLOSURE STATEMENT BY APPLICANT				Application Number	12/690,592	
				Filing Date	01/20/2010	
				First Named Inventor	Geoffrey B. Hoese	
				Group Art Unit	2111	
				Examiner Name	Unknown	
Sheet	2	of	9	Attorney Docket Number	CROSS1120-33	
U.S. PATENT DOCUMENTS						
Examiner Initials	Cite No.	Document Number		Publication Date MM-DD-YYYY	Name of Patentee or Applicant of Cited Document	Pages, Columns, Lines Where Relevant Passages or Figures Appear
		Number-Kind Code (if known)				
	A39	5,212,785		5/18/1993	Powers, et al.	
	A40	5,214,778		5/25/1993	Glider, et al.	
	A41	5,226,143		7/6/1993	Baird, et al.	
	A42	5,239,632		8/24/1993	Larner	
	A43	5,239,643		8/24/1993	Blount, et al.	
	A44	5,239,654		8/24/1993	Ing-Simmons, et al.	
	A45	5,247,638		9/21/1993	O'Brien, et al.	
	A46	5,247,692		9/21/1993	Fujimura	
	A47	5,257,386		10/26/1993	Saito	
	A48	5,297,262		3/22/1994	Cox, et al.	
	A49	5,301,290		4/5/1994	Tetzlaff, et al.	
	A50	5,315,657		5/24/1994	Abadi, et al.	
	A51	5,317,693		5/31/1994	Elko, et al.	
	A52	5,331,673		7/19/1994	Elko, et al.	
	A53	5,347,384		9/13/1994	McReynolds, et al.	
	A54	5,355,453		10/11/1994	Glider, et al.	
	A55	5,361,347		11/1/1994	Glider, et al.	
	A56	5,367,646		11/22/1994	Pardillos, et al.	
	A57	5,379,385		1/3/1995	Shomler	
	A58	5,379,398		1/3/1995	Cohn, et al.	
	A59	5,388,243		2/7/1995	Glider, et al.	
	A60	5,388,246		2/7/1995	Kasi	
	A61	5,394,402		2/28/1995	Ross, et al.	
	A62	5,394,526		2/28/1995	Crouse et al.	
	A63	5,396,596		3/7/1995	Hashemi, et al.	
	A64	5,403,639		4/4/1995	Belsan, et al.	
	A65	5,410,667		4/25/1995	Belsan, et al.	
	A66	5,410,697		4/25/1995	Baird, et al.	
	A67	5,414,820		10/9/1995	McFarland, et al.	
	A68	5,416,915		5/16/1995	Mattson, et al.	
Examiner Signature		/Christopher Shin/			Date Considered	08/26/2010

Change(s) applied
to document,
/A.E.M./
3/17/2011

05

ALL REFERENCES CONSIDERED EXCEPT WHERE LINED THROUGH. /C.S./

Application Number 	Application/Control No. 12/690,592	Applicant(s)/Patent under Reexamination HOESE ET AL.	

Document Code - DISQ	Internal Document – DO NOT MAIL
-----------------------------	----------------------------------------

TERMINAL DISCLAIMER	<input type="checkbox"/> APPROVED	<input checked="" type="checkbox"/> DISAPPROVED
Date Filed : 12/10/10	This patent is subject to a Terminal Disclaimer	

Approved/Disapproved by:
Td has wrong filling date it should be 1/20/10 not 9/2/09. Jean Proctor

U.S. Patent and Trademark Office



UNITED STATES PATENT AND TRADEMARK OFFICE

UNITED STATES DEPARTMENT OF COMMERCE
United States Patent and Trademark Office
Address: COMMISSIONER FOR PATENTS
P.O. Box 1450
Alexandria, Virginia 22313-1450
www.uspto.gov

NOTICE OF ALLOWANCE AND FEE(S) DUE

44654 7590 01/10/2011
Sprinkle IP Law Group
1301 W. 25th Street
Site 408
Austin, TX 78705

EXAMINER

SHIN, CHRISTOPHER B

ART UNIT PAPER NUMBER

2181

DATE MAILED: 01/10/2011

Table with 5 columns: APPLICATION NO., FILING DATE, FIRST NAMED INVENTOR, ATTORNEY DOCKET NO., CONFIRMATION NO.
12/690,592 01/20/2010 Geoffrey B. Hoese CROSS1120-33 8115
TITLE OF INVENTION: STORAGE ROUTER AND METHOD FOR PROVIDING VIRTUAL LOCAL STORAGE

Table with 7 columns: APPLN. TYPE, SMALL ENTITY, ISSUE FEE DUE, PUBLICATION FEE DUE, PREV. PAID ISSUE FEE, TOTAL FEE(S) DUE, DATE DUE
nonprovisional NO \$1510 \$300 \$0 \$1810 04/11/2011

THE APPLICATION IDENTIFIED ABOVE HAS BEEN EXAMINED AND IS ALLOWED FOR ISSUANCE AS A PATENT. PROSECUTION ON THE MERITS IS CLOSED. THIS NOTICE OF ALLOWANCE IS NOT A GRANT OF PATENT RIGHTS. THIS APPLICATION IS SUBJECT TO WITHDRAWAL FROM ISSUE AT THE INITIATIVE OF THE OFFICE OR UPON PETITION BY THE APPLICANT. SEE 37 CFR 1.313 AND MPEP 1308.

THE ISSUE FEE AND PUBLICATION FEE (IF REQUIRED) MUST BE PAID WITHIN THREE MONTHS FROM THE MAILING DATE OF THIS NOTICE OR THIS APPLICATION SHALL BE REGARDED AS ABANDONED. THIS STATUTORY PERIOD CANNOT BE EXTENDED. SEE 35 U.S.C. 151. THE ISSUE FEE DUE INDICATED ABOVE DOES NOT REFLECT A CREDIT FOR ANY PREVIOUSLY PAID ISSUE FEE IN THIS APPLICATION. IF AN ISSUE FEE HAS PREVIOUSLY BEEN PAID IN THIS APPLICATION (AS SHOWN ABOVE), THE RETURN OF PART B OF THIS FORM WILL BE CONSIDERED A REQUEST TO REAPPLY THE PREVIOUSLY PAID ISSUE FEE TOWARD THE ISSUE FEE NOW DUE.

HOW TO REPLY TO THIS NOTICE:

I. Review the SMALL ENTITY status shown above.

If the SMALL ENTITY is shown as YES, verify your current SMALL ENTITY status:

- A. If the status is the same, pay the TOTAL FEE(S) DUE shown above.
B. If the status above is to be removed, check box 5b on Part B - Fee(s) Transmittal and pay the PUBLICATION FEE (if required) and twice the amount of the ISSUE FEE shown above, or

If the SMALL ENTITY is shown as NO:

- A. Pay TOTAL FEE(S) DUE shown above, or
B. If applicant claimed SMALL ENTITY status before, or is now claiming SMALL ENTITY status, check box 5a on Part B - Fee(s) Transmittal and pay the PUBLICATION FEE (if required) and 1/2 the ISSUE FEE shown above.

II. PART B - FEE(S) TRANSMITTAL, or its equivalent, must be completed and returned to the United States Patent and Trademark Office (USPTO) with your ISSUE FEE and PUBLICATION FEE (if required). If you are charging the fee(s) to your deposit account, section "4b" of Part B - Fee(s) Transmittal should be completed and an extra copy of the form should be submitted. If an equivalent of Part B is filed, a request to reapply a previously paid issue fee must be clearly made, and delays in processing may occur due to the difficulty in recognizing the paper as an equivalent of Part B.

III. All communications regarding this application must give the application number. Please direct all communications prior to issuance to Mail Stop ISSUE FEE unless advised to the contrary.

IMPORTANT REMINDER: Utility patents issuing on applications filed on or after Dec. 12, 1980 may require payment of maintenance fees. It is patentee's responsibility to ensure timely payment of maintenance fees when due.

PART B - FEE(S) TRANSMITTAL

**Complete and send this form, together with applicable fee(s), to: Mail Mail Stop ISSUE FEE
 Commissioner for Patents
 P.O. Box 1450
 Alexandria, Virginia 22313-1450
 or Fax (571)-273-2885**

INSTRUCTIONS: This form should be used for transmitting the ISSUE FEE and PUBLICATION FEE (if required). Blocks 1 through 5 should be completed where appropriate. All further correspondence including the Patent, advance orders and notification of maintenance fees will be mailed to the current correspondence address as indicated unless corrected below or directed otherwise in Block 1, by (a) specifying a new correspondence address; and/or (b) indicating a separate "FEE ADDRESS" for maintenance fee notifications.

CURRENT CORRESPONDENCE ADDRESS (Note: Use Block 1 for any change of address)

Note: A certificate of mailing can only be used for domestic mailings of the Fee(s) Transmittal. This certificate cannot be used for any other accompanying papers. Each additional paper, such as an assignment or formal drawing, must have its own certificate of mailing or transmission.

44654 7590 01/10/2011
 Sprinkle IP Law Group
 1301 W. 25th Street
 Site 408
 Austin, TX 78705

Certificate of Mailing or Transmission
 I hereby certify that this Fee(s) Transmittal is being deposited with the United States Postal Service with sufficient postage for first class mail in an envelope addressed to the Mail Stop ISSUE FEE address above, or being facsimile transmitted to the USPTO (571) 273-2885, on the date indicated below.

_____ (Depositor's name)
_____ (Signature)
_____ (Date)

APPLICATION NO.	FILING DATE	FIRST NAMED INVENTOR	ATTORNEY DOCKET NO.	CONFIRMATION NO.
12/690,592	01/20/2010	Geoffrey B. Hoese	CROSS1120-33	8115

TITLE OF INVENTION: STORAGE ROUTER AND METHOD FOR PROVIDING VIRTUAL LOCAL STORAGE

APPLN. TYPE	SMALL ENTITY	ISSUE FEE DUE	PUBLICATION FEE DUE	PREV. PAID ISSUE FEE	TOTAL FEE(S) DUE	DATE DUE
nonprovisional	NO	\$1510	\$300	\$0	\$1810	04/11/2011

EXAMINER	ART UNIT	CLASS-SUBCLASS
SHIN, CHRISTOPHER B	2181	710-305000

1. Change of correspondence address or indication of "Fee Address" (37 CFR 1.363). <input type="checkbox"/> Change of correspondence address (or Change of Correspondence Address Form PTO/SB/122) attached. <input type="checkbox"/> "Fee Address" indication (or "Fee Address" Indication form PTO/SB/47; Rev. 03-02 or more recent) attached. Use of a Customer Number is required.	2. For printing on the patent front page, list (1) the names of up to 3 registered patent attorneys or agents OR, alternatively, (2) the name of a single firm (having as a member a registered attorney or agent) and the names of up to 2 registered patent attorneys or agents. If no name is listed, no name will be printed. 1 _____ 2 _____ 3 _____
-----------------------------------------------------------------------------------------------------------------------------------------------------------------------------------------------------------------------------------------------------------------------------------------------------------------------------------------------------------------------------------------------------	--------------------------------------------------------------------------------------------------------------------------------------------------------------------------------------------------------------------------------------------------------------------------------------------------------------------------------------------------------------------------

3. ASSIGNEE NAME AND RESIDENCE DATA TO BE PRINTED ON THE PATENT (print or type)
 PLEASE NOTE: Unless an assignee is identified below, no assignee data will appear on the patent. If an assignee is identified below, the document has been filed for recordation as set forth in 37 CFR 3.11. Completion of this form is NOT a substitute for filing an assignment.

(A) NAME OF ASSIGNEE _____ (B) RESIDENCE: (CITY and STATE OR COUNTRY) _____

Please check the appropriate assignee category or categories (will not be printed on the patent): Individual Corporation or other private group entity Government

4a. The following fee(s) are submitted: <input type="checkbox"/> Issue Fee <input type="checkbox"/> Publication Fee (No small entity discount permitted) <input type="checkbox"/> Advance Order - # of Copies _____	4b. Payment of Fee(s): (Please first reapply any previously paid issue fee shown above) <input type="checkbox"/> A check is enclosed. <input type="checkbox"/> Payment by credit card. Form PTO-2038 is attached. <input type="checkbox"/> The Director is hereby authorized to charge the required fee(s), any deficiency, or credit any overpayment, to Deposit Account Number _____ (enclose an extra copy of this form).
------------------------------------------------------------------------------------------------------------------------------------------------------------------------------------------------------------------------------	---------------------------------------------------------------------------------------------------------------------------------------------------------------------------------------------------------------------------------------------------------------------------------------------------------------------------------------------------------------------------------------------------------------------------------------

5. Change in Entity Status (from status indicated above)
 a. Applicant claims SMALL ENTITY status. See 37 CFR 1.27. b. Applicant is no longer claiming SMALL ENTITY status. See 37 CFR 1.27(g)(2).

NOTE: The Issue Fee and Publication Fee (if required) will not be accepted from anyone other than the applicant; a registered attorney or agent; or the assignee or other party in interest as shown by the records of the United States Patent and Trademark Office.

Authorized Signature _____ Date _____
 Typed or printed name _____ Registration No. _____

This collection of information is required by 37 CFR 1.311. The information is required to obtain or retain a benefit by the public which is to file (and by the USPTO to process) an application. Confidentiality is governed by 35 U.S.C. 122 and 37 CFR 1.14. This collection is estimated to take 12 minutes to complete, including gathering, preparing, and submitting the completed application form to the USPTO. Time will vary depending upon the individual case. Any comments on the amount of time you require to complete this form and/or suggestions for reducing this burden, should be sent to the Chief Information Officer, U.S. Patent and Trademark Office, U.S. Department of Commerce, P.O. Box 1450, Alexandria, Virginia 22313-1450. DO NOT SEND FEES OR COMPLETED FORMS TO THIS ADDRESS. SEND TO: Commissioner for Patents, P.O. Box 1450, Alexandria, Virginia 22313-1450.

Under the Paperwork Reduction Act of 1995, no persons are required to respond to a collection of information unless it displays a valid OMB control number.



UNITED STATES PATENT AND TRADEMARK OFFICE

UNITED STATES DEPARTMENT OF COMMERCE
United States Patent and Trademark Office
Address: COMMISSIONER FOR PATENTS
P.O. Box 1450
Alexandria, Virginia 22313-1450
www.uspto.gov

Table with 5 columns: APPLICATION NO., FILING DATE, FIRST NAMED INVENTOR, ATTORNEY DOCKET NO., CONFIRMATION NO. Includes details for application 12/690,592 filed 01/20/2010 by Geoffrey B. Hoese, attorney CROSS1120-33, examiner SHIN, CHRISTOPHER B, art unit 2181, and date mailed 01/10/2011.

Determination of Patent Term Adjustment under 35 U.S.C. 154 (b)

(application filed on or after May 29, 2000)

The Patent Term Adjustment to date is 0 day(s). If the issue fee is paid on the date that is three months after the mailing date of this notice and the patent issues on the Tuesday before the date that is 28 weeks (six and a half months) after the mailing date of this notice, the Patent Term Adjustment will be 0 day(s).

If a Continued Prosecution Application (CPA) was filed in the above-identified application, the filing date that determines Patent Term Adjustment is the filing date of the most recent CPA.

Applicant will be able to obtain more detailed information by accessing the Patent Application Information Retrieval (PAIR) WEB site (http://pair.uspto.gov).

Any questions regarding the Patent Term Extension or Adjustment determination should be directed to the Office of Patent Legal Administration at (571)-272-7702. Questions relating to issue and publication fee payments should be directed to the Customer Service Center of the Office of Patent Publication at 1-(888)-786-0101 or (571)-272-4200.

Notice of Allowability	Application No.	Applicant(s)	
	12/690,592	HOESE ET AL.	
	Examiner	Art Unit	
	Christopher B. Shin	2181	

-- The MAILING DATE of this communication appears on the cover sheet with the correspondence address--

All claims being allowable, PROSECUTION ON THE MERITS IS (OR REMAINS) CLOSED in this application. If not included herewith (or previously mailed), a Notice of Allowance (PTOL-85) or other appropriate communication will be mailed in due course. **THIS NOTICE OF ALLOWABILITY IS NOT A GRANT OF PATENT RIGHTS.** This application is subject to withdrawal from issue at the initiative of the Office or upon petition by the applicant. See 37 CFR 1.313 and MPEP 1308.

1. This communication is responsive to the Amendment received December 10, 2010.
2. The allowed claim(s) is/are 1-53.
3. Acknowledgment is made of a claim for foreign priority under 35 U.S.C. § 119(a)-(d) or (f).
 - a) All b) Some* c) None of the:
 1. Certified copies of the priority documents have been received.
 2. Certified copies of the priority documents have been received in Application No. _____ .
 3. Copies of the certified copies of the priority documents have been received in this national stage application from the International Bureau (PCT Rule 17.2(a)).

* Certified copies not received: _____.

Applicant has THREE MONTHS FROM THE "MAILING DATE" of this communication to file a reply complying with the requirements noted below. Failure to timely comply will result in ABANDONMENT of this application.
THIS THREE-MONTH PERIOD IS NOT EXTENDABLE.

4. A SUBSTITUTE OATH OR DECLARATION must be submitted. Note the attached EXAMINER'S AMENDMENT or NOTICE OF INFORMAL PATENT APPLICATION (PTO-152) which gives reason(s) why the oath or declaration is deficient.
 5. CORRECTED DRAWINGS (as "replacement sheets") must be submitted.
 - (a) including changes required by the Notice of Draftsperson's Patent Drawing Review (PTO-948) attached
 - 1) hereto or 2) to Paper No./Mail Date _____.
 - (b) including changes required by the attached Examiner's Amendment / Comment or in the Office action of Paper No./Mail Date _____.
- Identifying indicia such as the application number (see 37 CFR 1.84(c)) should be written on the drawings in the front (not the back) of each sheet. Replacement sheet(s) should be labeled as such in the header according to 37 CFR 1.121(d).**
6. DEPOSIT OF and/or INFORMATION about the deposit of BIOLOGICAL MATERIAL must be submitted. Note the attached Examiner's comment regarding REQUIREMENT FOR THE DEPOSIT OF BIOLOGICAL MATERIAL.

Attachment(s)

- | | |
|--------------------------------------------------------------------------------------------------------------------------------------------------------------------------------------------------------------------------------------------------------------------------------------------------------------------------------------------------------------------------------------------------------------------------------------------------------------------------------------|------------------------------------------------------------------------------------------------------------------------------------------------------------------------------------------------------------------------------------------------------------------------------------------------------------------------------------------------------------------------------------------------------------------------------|
| <ol style="list-style-type: none"> 1. <input type="checkbox"/> Notice of References Cited (PTO-892) 2. <input type="checkbox"/> Notice of Draftsperson's Patent Drawing Review (PTO-948) 3. <input checked="" type="checkbox"/> Information Disclosure Statements (PTO/SB/08),
Paper No./Mail Date <u>Multiple Pages filed</u> 4. <input type="checkbox"/> Examiner's Comment Regarding Requirement for Deposit of Biological Material | <ol style="list-style-type: none"> 5. <input type="checkbox"/> Notice of Informal Patent Application 6. <input type="checkbox"/> Interview Summary (PTO-413),
Paper No./Mail Date _____ . 7. <input type="checkbox"/> Examiner's Amendment/Comment 8. <input type="checkbox"/> Examiner's Statement of Reasons for Allowance 9. <input type="checkbox"/> Other _____. |
|--------------------------------------------------------------------------------------------------------------------------------------------------------------------------------------------------------------------------------------------------------------------------------------------------------------------------------------------------------------------------------------------------------------------------------------------------------------------------------------|------------------------------------------------------------------------------------------------------------------------------------------------------------------------------------------------------------------------------------------------------------------------------------------------------------------------------------------------------------------------------------------------------------------------------|

/Christopher B Shin/
Primary Examiner, Art Unit 2181

Search Notes



Application/Control No.

12/690,592

Examiner

Christopher B. Shin

Applicant(s)/Patent under Reexamination

HOESE ET AL.

Art Unit

2181

SEARCHED

Class	Subclass	Date	Examiner
710	1-5,8-13,36-38,126-131	8/30/2010	CS
710	250, 305-	8/30/2010	CS
709	258	8/30/2010	CS
714	42	8/30/2010	CS
711	110-113	8/30/2010	CS

INTERFERENCE SEARCHED

Class	Subclass	Date	Examiner
710	305,11	12/15/2010	CS
709	258	12/15/2010	CS

**SEARCH NOTES
(INCLUDING SEARCH STRATEGY)**

	DATE	EXMR
PLUS from the parent cases	8/30/2010	CS
PALM- for double patenting	8/30/2010	CS
EAST (See notes for parent)	8/30/2010	CS
PARETN & RELATED CASES REVIEWED FOR THE ALLOWANCE	8/30/2010	CS
Reviewed IDS	8/30/2010	CS

INFORMATION DISCLOSURE STATEMENT				Application Number	12/690,592
				Filing or 371 (c) Date:	January 20, 2010
				First Named Inventor	Geoffrey B. Hoese
				Group Art Unit	2181
				Examiner Name	Shin, Christopher
Sheet	1	of	1	Atty Docket Number	CROSS1120-33

NON PATENT LITERATURE DOCUMENTS

Examiner Initials	Cite No.	Include name of the author (in CAPITAL LETTERS), title of the article (when appropriate), title of the item (book, magazine, journal, serial, symposium, catalog, etc.) date, page(s), volume-issue number(s), publisher, city and/or country where published	T ²
	C179	Office Action Mailed 12/02/10 in U.S. Serial No. 12/910,375	12/2/2010
	C180	Office Action Mailed 12/03/10 in U.S. Serial No. 12/910,431	12/3/2010
	C181	Office Action Mailed 12/03/10 in U.S. Serial No. 12/910,515	12/3/2010

Examiner Signature	/Christopher Shin/	Date Considered	12/17/2010
--------------------	--------------------	-----------------	------------

ALL REFERENCES CONSIDERED EXCEPT WHERE LINED THROUGH. /C.S./

Issue Classification 	Application/Control No. 12/690,592	Applicant(s)/Patent under Reexamination HOESE ET AL.
	Examiner Christopher B. Shin	Art Unit 2181

ISSUE CLASSIFICATION														
ORIGINAL					INTERNATIONAL CLASSIFICATION									
CLASS		SUBCLASS			CLAIMED					NON-CLAIMED				
710		305			G	06	F	13	/00	G	06	F	3	/0
CROSS REFERENCES														
CLASS	SUBCLASS (ONE SUBCLASS PER BLOCK)							/					/	
710	11							/					/	
709	258							/					/	
								/					/	
								/					/	
								/					/	
----- (Assistant Examiner) (Date)				/Christopher B Shin/ PRIMARY EXAMINER OF 2181					Total Claims Allowed: 53					
(Legal Instruments Examiner) (Date)				(Primary Examiner) (Date)					O.G. Print Claim(s) 1		O.G. Print Fig. 3			

<input checked="" type="checkbox"/> Claims renumbered in the same order as presented by applicant														<input type="checkbox"/> CPA		<input type="checkbox"/> T.D.		<input type="checkbox"/> R.1.47	
Final	Original	Final	Original	Final	Original	Final	Original	Final	Original	Final	Original	Final	Original	Final	Original				
	1		31		61		91		121		151		181		211				
	2		32		62		92		122		152		182		212				
	3		33		63		93		123		153		183		213				
	4		34		64		94		124		154		184		214				
	5		35		65		95		125		155		185		215				
	6		36		66		96		126		156		186		216				
	7		37		67		97		127		157		187		217				
	8		38		68		98		128		158		188		218				
	9		39		69		99		129		159		189		219				
	10		40		70		100		130		160		190		220				
	11		41		71		101		131		161		191		221				
	12		42		72		102		132		162		192		222				
	13		43		73		103		133		163		193		223				
	14		44		74		104		134		164		194		224				
	15		45		75		105		135		165		195		225				
	16		46		76		106		136		166		196		226				
	17		47		77		107		137		167		197		227				
	18		48		78		108		138		168		198		228				
	19		49		79		109		139		169		199		229				
	20		50		80		110		140		170		200		230				
	21		51		81		111		141		171		201		231				
	22		52		82		112		142		172		202		232				
	23		53		83		113		143		173		203		233				
	24		54		84		114		144		174		204		234				
	25		55		85		115		145		175		205		235				
	26		56		86		116		146		176		206		236				
	27		57		87		117		147		177		207		237				
	28		58		88		118		148		178		208		238				
	29		59		89		119		149		179		209		239				
	30		60		90		120		150		180		210		240				

	Type	Hits	Search Text	DBs
1	S&R	6	((("7340549") or ("7051147") or ("6789152") or ("6421753") or ("5941972") or ("20080307444")).PN.	US-PG PUB; USPAT

	Time Stamp	Comments	Error Definition	Errors	Ref #
1	2010/07/22 15:13				S1

INFORMATION DISCLOSURE STATEMENT				Application Number	12/690,592
				Filing or 371 (c) Date:	January 20, 2010
				First Named Inventor	Geoffrey B. Hoese
				Group Art Unit	2182
				Examiner Name	Unknown
Sheet	1	of	1	Atty Docket Number	CROSS1120-33

NON PATENT LITERATURE DOCUMENTS

Examiner Initials	Cite No.	Include name of the author (in CAPITAL LETTERS), title of the article (when appropriate), title of the item (book, magazine, journal, serial, symposium, catalog, etc.) date, page(s), volume-issue number(s), publisher, city and/or country where published	T ²
	C174	Office Action Mailed 09/13/10 in U.S. Serial No. 11/980,909	09/13/10
	C175	Office Action Mailed 09/13/10 in U.S. Serial No. 12/552,807	09/13/10
	C176	Office Action Mailed 09/15/10 in U.S. Serial No. 12/552,885	09/15/10
	C177	Office Action Mailed 09/23/10 in U.S. Serial No. 12/552,913	09/23/10

Examiner Signature	/Christopher Shin/	Date Considered	12/17/2010
---------------------------	--------------------	------------------------	------------

ALL REFERENCES CONSIDERED EXCEPT WHERE LINED THROUGH. /C.S./

INFORMATION DISCLOSURE STATEMENT				Application Number	12/690,592
				Filing or 371 (c) Date:	January 20, 2010
				First Named Inventor	Geoffrey B. Hoese
				Group Art Unit	2181
				Examiner Name	Shin, Christopher
Sheet	1	of	1	Atty Docket Number	CROSS1120-33
NON PATENT LITERATURE DOCUMENTS					
Examiner Initials	Cite No.	Include name of the author (in CAPITAL LETTERS), title of the article (when appropriate), title of the item (book, magazine, journal, serial, symposium, catalog, etc.) date, page(s), volume-issue number(s), publisher, city and/or country where published			T²
	C179	Office Action Mailed 12/02/10 in U.S. Serial No. 12/910,375			12/2/2010
	C180	Office Action Mailed 12/03/10 in U.S. Serial No. 12/910,431			12/3/2010
	C181	Office Action Mailed 12/03/10 in U.S. Serial No. 12/910,515			12/3/2010
Examiner Signature	/Christopher Shin/			Date Considered	01/02/2011

ALL REFERENCES CONSIDERED EXCEPT WHERE LINED THROUGH. /C.S./

IN THE UNITED STATES PATENT AND TRADEMARK OFFICE	
INFORMATION DISCLOSURE STATEMENT BY APPLICANT	Atty. Docket No. (Opt.) CROSS1120-33
Applicant Geoffrey B. Hoese	
Application Number 12/690,592	Filing or 371 (c) Date: 01/20/2010
For Storage Router and Method for Providing Virtual Local Storage	
Group Art Unit 2181	Examiner Shin, Christopher
Confirmation Number: 8115	

Commissioner for Patents
P.O. Box 1450
Alexandria, VA 22313-1450

Dear Sir,

<u>Certification of Transmission Under 37 C.F.R. 1.8</u>
I hereby certify that this correspondence is being transmitted to the Commissioner for Patents, P.O. Box 1450, Alexandria, VA 22312-1450 via the U.S. Patent and Trademark Office Electronic Filing System (EFS-Web) on December <u>17</u> , 2010.
 Janice Pampell

Applicant respectfully requests, pursuant to 37 C.F.R. §§ 1.56, 1.97 and 1.98, that the information listed on the attached SB08B form be considered and cited in the examination of the above-identified application. A copy of the information listed on the attached SB08B form is enclosed for the convenience of the Examiner.

This Information Disclosure Statement is being submitted within three months of the filing date of a national application other than a continued prosecution application under 37 C.F.R. § 1.53(d).

This Information Disclosure Statement is being submitted within three months of the date of entry of the national stage as set forth in 37 C.F.R. § 1.491 in an international application;

This Information Disclosure Statement is being submitted before the mailing of a first Office action on the merits; or

This Information Disclosure Statement is being submitted before the mailing of a first Office action after the filing of a request for continued examination under 37 C.F.R. § 1.114.

This Information Disclosure Statement is being submitted after the period specified in 37 C.F.R. § 1.97(b) and before the mailing date of any of a final action under 37 C.F.R. § 1.113, a notice of allowance under 37 C.F.R. § 1.311, or an action that otherwise closes prosecution in the application, and is accompanied by one of:

- The statement specified in 37 C.F.R. § 1.97(e); or
- The fee set forth in 37 C.F.R. § 1.17(p). Applicant hereby authorizes the Commissioner to deduct the amount of \$180 from Deposit Account No. 50-3183 of Sprinkle IP Law Group for the filing fee of this Information Disclosure Statement.

This Information Disclosure Statement is being submitted after the period specified in 37 C.F.R. § 1.97(c) and on or before payment of the issue fee and is accompanied by:

- The statement specified in 37 C.F.R. § 1.97(e); and
- The fee set forth in 37 C.F.R. § 1.17(p). Applicant hereby authorizes the Commissioner to deduct the amount of \$180 from Deposit Account No. 50-3183 of Sprinkle IP Law Group for the filing fee of this Information Disclosure Statement.

Applicant does not believe any fees are due for filing this Information Disclosure Statement; however, if Applicant is in error, the Director is hereby authorized to deduct any and all appropriate fees from Deposit Account 50-3183 of Sprinkle IP Law Group. Applicant respectfully submits that the claims of Applicant's above-referenced patent application are patentably distinguishable from the listed information.

Respectfully submitted,

Sprinkle IP Law Group
Attorneys for Applicant

John L. Adair
Reg. No. 48,828

Dated: Dec. 15, 2010

1301 W. 25th Street, Suite 408
Austin, Texas 78705
Tel. (512) 637-9220
Fax. (512) 317-9088

INFORMATION DISCLOSURE STATEMENT				Application Number	12/690,592
				Filing or 371 (c) Date:	January 20, 2010
				First Named Inventor	Geoffrey B. Hoese
				Group Art Unit	2181
				Examiner Name	Shin, Christopher
Sheet	1	of	1	Atty Docket Number	CROSS1120-33
NON PATENT LITERATURE DOCUMENTS					
Examiner Initials	Cite No.	Include name of the author (in CAPITAL LETTERS), title of the article (when appropriate), title of the item (book, magazine, journal, serial, symposium, catalog, etc.) date, page(s), volume-issue number(s), publisher, city and/or country where published			T ²
	C179	Office Action Mailed 12/02/10 in U.S. Serial No. 12/910,375			12/2/2010
	C180	Office Action Mailed 12/03/10 in U.S. Serial No. 12/910,431			12/3/2010
	C181	Office Action Mailed 12/03/10 in U.S. Serial No. 12/910,515			12/3/2010
Examiner Signature				Date Considered	

Electronic Patent Application Fee Transmittal

Application Number:	12690592			
Filing Date:	20-Jan-2010			
Title of Invention:	STORAGE ROUTER AND METHOD FOR PROVIDING VIRTUAL LOCAL STORAGE			
First Named Inventor/Applicant Name:	Geoffrey B. Hoese			
Filer:	John L. Adair/Janice Pampell			
Attorney Docket Number:	CROSS1120-33			
Filed as Large Entity				
Utility under 35 USC 111 (a) Filing Fees				
Description	Fee Code	Quantity	Amount	Sub-Total in USD(\$)
Basic Filing:				
Pages:				
Claims:				
Miscellaneous-Filing:				
Petition:				
Patent-Appeals-and-Interference:				
Post-Allowance-and-Post-Issuance:				
Extension-of-Time:				

Description	Fee Code	Quantity	Amount	Sub-Total in USD(\$)
Miscellaneous:				
Submission- Information Disclosure Stmt	1806	1	180	180
Total in USD (\$)				180

Electronic Acknowledgement Receipt

EFS ID:	9062027
Application Number:	12690592
International Application Number:	
Confirmation Number:	8115
Title of Invention:	STORAGE ROUTER AND METHOD FOR PROVIDING VIRTUAL LOCAL STORAGE
First Named Inventor/Applicant Name:	Geoffrey B. Hoese
Customer Number:	44654
Filer:	John L. Adair/Janice Pampell
Filer Authorized By:	John L. Adair
Attorney Docket Number:	CROSS1120-33
Receipt Date:	17-DEC-2010
Filing Date:	20-JAN-2010
Time Stamp:	14:07:18
Application Type:	Utility under 35 USC 111(a)

Payment information:

Submitted with Payment	yes
Payment Type	Deposit Account
Payment was successfully received in RAM	\$ 180
RAM confirmation Number	322
Deposit Account	503183
Authorized User	

The Director of the USPTO is hereby authorized to charge indicated fees and credit any overpayment as follows:

Charge any Additional Fees required under 37 C.F.R. Section 1.19 (Document supply fees)

Charge any Additional Fees required under 37 C.F.R. Section 1.20 (Post Issuance fees)

Charge any Additional Fees required under 37 C.F.R. Section 1.21 (Miscellaneous fees and charges)

File Listing:

Document Number	Document Description	File Name	File Size(Bytes)/ Message Digest	Multi Part /.zip	Pages (if appl.)
1	Information Disclosure Statement (IDS) Filed (SB/08)	CROSS1120-33_IDS_Filed_12-17-10.pdf	109107 80a5654afdcd449d01308e69e23ef5e486995055	no	3
Warnings:					
Information:					
This is not an USPTO supplied IDS fillable form					
2	NPL Documents	CROSS1120_Ref_C179.pdf	252415 ec33ebb937f62aea15cc667f0d4e7d15e2959906	no	7
Warnings:					
Information:					
3	NPL Documents	CROSS1120_Ref_C180.pdf	254399 845fbb723c26af4bb2f4aeece8f061856a612c5a2	no	7
Warnings:					
Information:					
4	NPL Documents	CROSS1120_Ref_C181.pdf	218169 5781d9e2b8edee132dd11ed8d451ded236d11aa8	no	6
Warnings:					
Information:					
5	Fee Worksheet (PTO-875)	fee-info.pdf	30500 614355e9e496790e3524127de0a0c0beaecd1c165	no	2
Warnings:					
Information:					
Total Files Size (in bytes):			864590		

This Acknowledgement Receipt evidences receipt on the noted date by the USPTO of the indicated documents, characterized by the applicant, and including page counts, where applicable. It serves as evidence of receipt similar to a Post Card, as described in MPEP 503.

New Applications Under 35 U.S.C. 111

If a new application is being filed and the application includes the necessary components for a filing date (see 37 CFR 1.53(b)-(d) and MPEP 506), a Filing Receipt (37 CFR 1.54) will be issued in due course and the date shown on this Acknowledgement Receipt will establish the filing date of the application.

National Stage of an International Application under 35 U.S.C. 371

If a timely submission to enter the national stage of an international application is compliant with the conditions of 35 U.S.C. 371 and other applicable requirements a Form PCT/DO/EO/903 indicating acceptance of the application as a national stage submission under 35 U.S.C. 371 will be issued in addition to the Filing Receipt, in due course.

New International Application Filed with the USPTO as a Receiving Office

If a new international application is being filed and the international application includes the necessary components for an international filing date (see PCT Article 11 and MPEP 1810), a Notification of the International Application Number and of the International Filing Date (Form PCT/RO/105) will be issued in due course, subject to prescriptions concerning national security, and the date shown on this Acknowledgement Receipt will establish the international filing date of the application.

IN THE UNITED STATES PATENT AND TRADEMARK OFFICE	
REPLY TO OFFICE ACTION DATED 09/10/2010	Atty. Docket No. CROSS1120-33
Applicant Geoffrey B. Hoese	
Application Number 12/690,592	Date Filed 01/20/10
Title Storage Router and Method for Providing Virtual Local Storage	
Group Art Unit 2181	Examiner Shin, Christopher
Confirmation Number: 8115	

Commissioner for Patents
P.O. Box 1450
Alexandria, VA 22313-1450

Dear Sir:

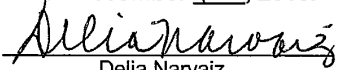
<u>Certificate of Transmission Under 37 C.F.R. § 1.8</u>
I hereby certify that this correspondence is being deposited electronically with the U.S. Patent and Trademark Office using the United States Patent and Trademark Office's EFS-Web system on December 10 , 2010.
 Delia Narvaiz

In response to the Official Action mailed September 10, 2010, Applicant respectfully requests the Examiner reconsider the rejections of the Claims in view of this reply.

IN THE SPECIFICATION:

Please replace paragraph [0001] with the following paragraph.

[0001] This application is a continuation of, and claims a benefit of priority under 35 U.S.C. 120 of the filing date of U.S. Patent Application Serial No. 12/552,885 entitled "Storage Router and Method for Providing Virtual Local Storage" filed 09/02/2009, which is a continuation of and claims the benefit of priority of U.S. Application Serial No. 11/851,724 entitled "Storage Router and Method for Providing Virtual Local Storage" filed 09/07/2007, now U.S. Patent No. 7,689,754 issued 03/30/2010, which is a continuation of and claims the benefit of priority of U.S. Patent Application Serial No. 11/442,878 entitled "Storage Router and Method for Providing Virtual Local Storage" filed 09/07/2007, now abandoned, which is a continuation of and claims the benefit of priority of U.S. Patent Application Serial No. 11/353,826 entitled "Storage Router and Method for Providing Virtual Local Storage" filed on 02/14/2006, now U.S. Patent No. 7,340,549 issued 03/04/2008, which is a continuation of and claims the benefit of priority of U.S. Patent Application Serial No. 10/658,163 entitled "Storage Router and Method for Providing Virtual Local Storage" filed on 09/09/2003 now U.S. Patent No. 7,051,147 issued 05/23/2006, which is a continuation of and claims the benefit of benefit of priority of U.S. Patent Application Serial No. 10/081,110 by inventors Geoffrey B. Hoese and Jeffery T. Russell, entitled "Storage Router and Method for Providing Virtual Local Storage" filed on 02/22/2002, now U.S. Patent No. 6,789,152 issued on 09/07/2004, which in turn is a continuation of and claims benefit of priority of U.S. Application No. 09/354,682 by inventors Geoffrey B. Hoese and Jeffery T. Russell, entitled "Storage Router and Method for Providing Virtual Local Storage" filed on 07/15/1999, now U.S. Patent No. 6,421,753 issued on 07/16/2002, which in turn is a continuation of and claims benefit of priority of U.S. Patent Application Serial No. 09/001,799, filed on 12/31/1997, now U.S. Patent No. 5,941,972 issued on 08/24/1999, and hereby incorporates these applications and patents by reference in their entireties as if they had been fully set forth herein.

IN THE CLAIMS:

Please amend the claims as follows:

1. (Original) A storage router for providing virtual local storage on remote storage devices, comprising:

a first controller operable to interface with a first transport medium, wherein the first medium is a serial transport media; and

a processing device coupled to the first controller, wherein the processing device is configured to:

maintain a map to allocate storage space on the remote storage devices to devices connected to the first transport medium by associating representations of the devices connected to the first transport medium with representations of storage space on the remote storage devices, wherein each representation of a device connected to the first transport medium is associated with one or more representations of storage space on the remote storage devices;

control access from the devices connected to the first transport medium to the storage space on the remote storage devices in accordance with the map; and

allow access from devices connected to the first transport medium to the remote storage devices using native low level block protocol.

2. (Original)The storage router of Claim 1, wherein the map associates a representation of storage space on the remote storage devices with multiple devices connected to the first transport medium.

3. (Original)The storage router of Claim 1, wherein the storage space on the remote storage devices comprises storage space on multiple remote storage devices.

4. (Original)The storage router of Claim 1, wherein the map associates a representation of a device connected to the first transport medium with a representation of an entire storage space of at least one remote storage device.

5. (Original)The storage router of Claim 1, wherein the map resides at the storage router and is maintained at the storage router.

6. (Original)The storage router of Claim 1, wherein the native low level block protocol is received at the storage router via the first transport medium and the processing device uses the received native low level block protocol to allow the devices connected to the first transport medium access to storage space specifically allocated to them in the map.

7. (Original)The storage router of Claim 1, wherein the storage router is configured to receive commands according to a first low level block protocol from the device connected to the first transport medium and forward commands according to a second low level block protocol to the remote storage devices.

8. (Original)The storage router of Claim 7, wherein the first low level block protocol is an FCP protocol and the second low level block protocol is a protocol other than FCP.

9. (Original)The storage router of Claim 1, wherein the map comprises one or more tables.

10. (Original)The storage router of Claim 1, wherein the virtual local storage is provided to the devices connected to the first transport medium in a manner that is transparent to the devices and wherein the storage space allocated to the devices connected to the first transport medium appears to the devices as local storage.

11. (Original)The storage router of Claim 1, wherein the storage router provides centralized control of what the devices connected to the first transport medium see as local storage.

12. (Original)The storage router of Claim 1, wherein the representations of storage space comprise logical unit numbers that represent a subset of storage on the remote storage devices.

13. (Original)The storage router of Claim 12, wherein the storage router is operable to route requests to the same logical unit number from different devices connected to the first transport medium to different subsets of storage space on the remote storage devices.

14. (Original)The storage router of Claim 1, wherein the representations of devices connected to the first transport medium are unique identifiers.

15. (Original)The storage router of Claim 14, wherein the unique identifiers are world wide names.

16. (Original)The storage router of Claim 1, wherein the storage router is configured to allow modification of the map in a manner transparent to and without involvement of the devices connected to the first transport medium.

17. (Original)The storage router of Claim 1, wherein the processing device is a microprocessor.

18. (Original)The storage router of Claim 1, wherein the processing device is a microprocessor and associated logic to implement a stand-alone processing system.

19. (Original)The storage router of Claim 1, wherein the first transport medium is a fibre channel transport medium and further comprising a second transport medium connected to the remote storage devices that is a fibre channel transport medium.

20. (Original)A storage network comprising:
a set of devices connected a first transport medium, wherein the first transport medium;
a set of remote storage devices connected to a second transport medium;
a storage router connected to the serial transport medium;
a storage router connected to the first transport medium and second transport medium to provide virtual local storage on the remote storage devices, the storage router configured to:
maintain a map to allocate storage space on the remote storage devices to devices connected to the first transport medium by associating representations of the devices connected to the first transport medium with representations of storage space on the remote

storage devices, wherein each representation of a device connected to the first transport medium is associated with one or more representations of storage space on the remote storage devices;

control access from the devices connected to the first transport medium to the storage space on the remote storage devices in accordance with the map; and

allow access from devices connected to the first transport medium to the remote storage devices using native low level block protocol.

21. (Original)The storage network of Claim 20, wherein the map associates a representation of storage space on the remote storage devices with multiple devices connected to the first transport medium.

22. (Original)The storage network of Claim 20, wherein the storage space on the remote storage devices comprises storage space on multiple remote storage devices.

23. (Original)The storage network of Claim 20, wherein the map associates a representation of a device connected to the first transport medium with a representation of an entire storage space of at least one remote storage device.

24. (Original)The storage network of Claim 20, wherein the map resides at the storage router and is maintained at the storage router.

25. (Original)The storage network of Claim 20, wherein the native low level block protocol is received at the storage router via the first transport medium and the storage router uses the received native low level block protocol to allow the devices connected to the first transport medium access to storage space specifically allocated to them in the map.

26. (Original)The storage router of Claim 20, wherein the storage router is configured to receive commands according to a first low level block protocol from the device connected to the first transport medium and forward commands according to a second low level block protocol to the remote storage devices.

27. (Original)The storage network of Claim 20, wherein the first low level block protocol is an FCP protocol and the second low level block protocol is a protocol other than FCP.
28. (Original)The storage network of Claim 20, wherein the map comprises one or more tables.
29. (Original)The storage network of Claim 20, wherein the virtual local storage is provided to the devices connected to the first transport medium in a manner that is transparent to the devices and wherein the storage space allocated to the devices connected to the first transport medium appears to the devices as local storage.
30. (Original)The storage network of Claim 20, wherein the storage router provides centralized control of what the devices connected to the first transport medium see as local storage.
31. (Original)The storage network of Claim 20, wherein the representations of storage space comprise logical unit numbers that represent a subset of storage on the remote storage devices.
32. (Original)The storage network of Claim 31, wherein the storage router is operable to route requests to the same logical unit number from different devices connected to the first transport medium to different subsets of storage space on the remote storage devices.
33. (Original)The storage network of Claim 20, wherein the representations of devices connected to the first transport medium are unique identifiers.
34. (Original)The storage network of Claim 33, wherein the unique identifiers are world wide names.
35. (Original)The storage network of Claim 20, wherein the storage router is configured to allow modification of the map in a manner transparent to and without involvement of the devices connected to the first transport medium.

36. (Original)The storage network of Claim 20, wherein the first transport medium is a fibre channel transport medium and the second transport medium is a fibre channel transport medium.

37. (Original)A method for providing virtual local storage on remote storage devices comprising:

connecting a storage router between a set of devices connected to a first transport medium and a set of remote storage devices, wherein the first transport medium is a serial transport medium;

maintaining a map at the storage router to allocate storage space on the remote storage devices to devices connected to the first transport medium by associating representations of the devices connected to the first transport medium with representations of storage space on the remote storage devices, wherein each representation of a device connected to the first transport medium is associated with one or more representations of storage space on the remote storage devices;

controlling access from the devices connected to the first transport medium to the storage space on the remote storage devices in accordance with the map; and

allowing access from devices connected to the first transport medium to the remote storage devices using native low level block protocol.

38. (Original)The method of Claim 37, wherein the map associates a representation of storage space on the remote storage devices with multiple devices connected to the first transport medium.

39. (Original)The method of Claim 37, wherein the storage space on the remote storage devices comprises storage space on multiple remote storage devices.

40. (Original)The method of Claim 37, wherein the map associates a representation of a device connected to the first transport medium with a representation of an entire storage space of at least one remote storage device.

41. (Original)The method of Claim 37, wherein the map resides at the storage router and is maintained at the storage router.

42. (Original)The method of Claim 37, further comprising:
receiving the native low level block protocol at the storage router via the first transport medium;

using the received native low level block protocol at the storage router to allow the devices connected to the first transport medium access to storage space specifically allocated to them in the map.

43. (Original)The method of Claim 37, further comprising receiving commands at the storage router according to a first low level block protocol from the device connected to the first transport medium and forwarding commands according to a second low level block protocol to the remote storage devices.

44. (Original)The method of Claim 43, wherein the first low level block protocol is an FCP protocol and the second low level block protocol is a protocol other than FCP.

45. (Original)The method of Claim 37, wherein the map comprises one or more tables.

46. (Original)The method of Claim 37, wherein the virtual local storage is provided to the devices connected to the first transport medium in a manner that is transparent to the devices and wherein the storage space allocated to the devices connected to the first transport medium appears to the devices as local storage.

47. (Original)The method of Claim 37, wherein the storage router provides centralized control of what the devices connected to the first transport medium see as local storage.

48. (Original)The method of Claim 37, wherein the representations of storage space comprise logical unit numbers that represent a subset of storage on the remote storage devices.

49. (Original)The method of Claim 48, wherein the storage router is operable to route requests to the same logical unit number from different devices connected to the first transport medium to different subsets of storage space on the remote storage devices.

50. (Original)The method of Claim 37, wherein the representations of devices connected to the first transport medium are unique identifiers.

51. (Original)The method of Claim 50, wherein the unique identifiers are world wide names.

52. (Original)The method of Claim 51, wherein the storage router is configured to allow modification of the map in a manner transparent to and without involvement of the devices connected to the first transport medium.

53. (Original)The method of Claim 1 wherein connecting the storage router between a set of devices connected to a first transport medium and a set of remote storage devices further comprises connecting the storage router between a first fibre channel transport medium and a second fibre channel transport medium.

INTERVIEW SUMMARY

On August 30, 2010, John L. Adair and Examiner Shin held a telephonic interview regarding United States Patent Application Serial No. 11/947,499 (the “499 Application”), United States Patent Application Serial No. 11/980,909 (the “909 Application”), United States Patent Application Serial No. 12/552,885 and United States Patent Application Serial No. 12/552,913 and United States Patent Application No. 12/690,592 (the ‘592 Application). Applicant pointed out the transport mediums could be the same or different types of transport mediums and, for example, that i) the specification describes a Fibre Channel-to-Fibre Channel mode of operation and ii) issued United States Patent No. 7,051,147 claims a Fibre Channel-to-Fibre Channel system. Applicant also pointed out that other patents have issued that recite first and second transport mediums without requiring that the transport mediums use different protocols. The Examiner agreed that in the various cases, while the transport mediums may be different (e.g., separated by a storage router in the case of Claim 1 of the ‘499 Application), the transport mediums can use the same or different protocols and the ‘low level block protocol’ in the same medium types is consistent with the parent patents/specifications.

Furthermore, in the August 30, 2010 interview, Applicant pointed out that the term “remote” was construed to mean “indirectly connected through at least one serial network transport medium” (emphasis added). Crossroads v. Dot Hill Systems Corporation, Western District of Texas, Civil Action No. A-03-CA-754-SS. Therefore, the recitation of “remote” in various claims of the related applications addresses the fact that the transport mediums are different so that storage is indirectly connected to hosts (e.g., through a storage router in the case of Claim 1 of the ‘499 Application). Applicant agreed to review the claims of the related applications and specifically to amend the claims of the ‘909 Application to clarify that the storage devices are remote from the hosts. While Applicant and the Examiner discussed the other related cases generally, they did not discuss specific claims.

To the extent the Examiner’s statement that one transport medium is “remote, separate and different” may be interpreted to mean anything different than that the transport mediums are different/separate so that storage is indirectly connected to hosts (e.g., through a storage router in the case of Claim 1 of the ‘499 Application) and that at least one of the transport mediums is a serial transport medium, Applicant disagrees with such an interpretation. As pointed out in the interview, the transport mediums can be the same type of transport mediums or different types of transport mediums.

Applicant agreed to file an updated terminal disclaimer and amend the Related Applications section as needed.

REMARKS

Applicant appreciates the time taken by the Examiner to review Applicant's present application. This application has been carefully reviewed in light of the Official Action mailed September 10, 2010. Applicant respectfully requests reconsideration and favorable action in this case.

Double Patenting Rejection

Claims 1-53 were rejected under the judicially created doctrine of obviousness-type double patenting as being unpatentable over claims of U.S. Patent Nos. 7,051,147, 5,941,972, 7,340,549, 7,689,754, 7,552,266, 7,694,058, 6,421,753, 6,425,036, 6,425,035, 6,789,152, 6,738,854 and 6,763,419 and were provisionally rejected under the judicially created doctrine of obviousness-type double patenting as being unpatentable over U.S. Patent Application Nos. 11/980,909, 11/947,499, 12/220,431, 12/552,807, 12/552,885, 12/552,913, 12/910,431, 12/910,375, 12/910,476 and 12/910,515. Applicant is including with this reply a timely filed terminal disclaimer in compliance with 37 C.F.R. § 1.321(c). U.S. Patent Nos. 7,051,147, 5,941,972, 7,340,549, 7,689,754, 7,552,266, 7,694,058, 6,421,753, 6,425,036, 6,425,035, 6,789,152, 6,738,854 and 6,763,419 and U.S. Patent Application Nos. 11/980,909, 11/947,499, 12/220,431, 12/552,807, 12/552,885, 12/552,913, 12/910,431, 12/910,375, 12/910,476 and 12/910,515 and the current Application are commonly owned. Accordingly, withdrawal of this rejection is respectfully requested.

Specification

The specification was objected to for informalities. An amended paragraph [0001] is submitted to update the related applications. Accordingly, withdrawal of this objection is requested.

IDS REFERENCES

Applicant filed information disclosure statements (IDS) citing the related art of record in the present application on May 21, 2010, June 9, 2010 and August 20, 2010. The Applicant notes that the Office Action mailed September 10, 2010 was accompanied by a copy of the listing of references, with an indication by the Examiner to indicate what references cited therein were considered.

Conclusion

Applicant has now made an earnest attempt to place this case in condition for allowance. Other than as explicitly set forth above, this reply does not include an acquiescence to statements, assertions, assumptions, conclusions, or any combination thereof in the Office Action. For the foregoing reasons and for other reasons clearly apparent, Applicant respectfully requests full allowance of Claims 1-53. The Examiner is invited to telephone the undersigned at the number listed below for prompt action in the event any issues remain.

The Director of the U.S. Patent and Trademark Office is hereby authorized to charge any fees or credit any overpayments to Deposit Account No. 50-3183 of Sprinkle IP Law Group.

Respectfully submitted,

Sprinkle IP Law Group
Attorneys for Applicant

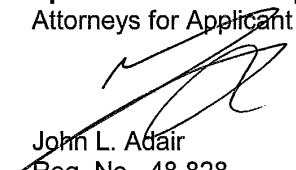
John L. Adair
Reg. No. 48,828

Date: December 10, 2010

1301 W. 25th Street, Suite 408
Austin, TX 78705
Tel. (512) 637-9220
Fax. (512) 371-9088

IN THE UNITED STATES PATENT AND TRADEMARK OFFICE	
Terminal Disclaimer	Atty. Docket No. CROSS1120-33
Applicant Geoffrey B. Hoese, et al.	
Application Number 12/690,592	Date Filed 09/02/2009
Title STORAGE ROUTER AND METHOD FOR PROVIDING VIRTUAL LOCAL STORAGE	
Group Art Unit 2181	Examiner SHIN, Christopher B.
Confirmation Number: 5330	

Commissioner for Patents
P.O. Box 1450
Alexandria, VA 22313-1450

Dear Sir:

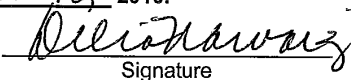
<u>Certificate of Mailing</u>
I hereby certify that this correspondence is being filed via electronically using the U.S. Patent Office EFS-Web system on <u>December 10,</u> 2010.
 Signature
<u>Delia Narvaiz</u> Printed Name

Crossroads Systems, Inc., the owner of one hundred percent (100%) interest in the instant application, except as provided below:

i) The terminal part of the statutory term of any patent granted on the instant application, which would extend beyond the expiration date of the full statutory term defined in 35 U.S.C. § 154 and 173 of U.S. Patent No. 5,941,972. In making the above disclaimer, the owner does not disclaim the terminal part of any patent granted on the instant application that would extend to the expiration date of the full statutory term as defined in 35 U.S.C. § 154 and 173 of U.S. Patent No. 5,941,972, in the event that it later: expires for failure to pay a maintenance fee, is held unenforceable, is found invalid by a court of competent jurisdiction, is statutorily disclaimed in whole or terminally disclaimed under 37 C.F.R. 1.321, has all claims canceled by a reexamination certificate, is reissued, or is in any manner terminated prior to the expiration of its full statutory term.

ii) The terminal part of the statutory term of any patent granted on the instant application, which would extend beyond the expiration date of the full statutory term defined in 35 U.S.C. § 154 and 173 of U.S. Patent No. 6,421,753 as presently shortened by terminal disclaimer. In making the above disclaimer, the owner does not disclaim the terminal part of any patent

granted on the instant application that would extend to the expiration date of the full statutory term as defined in 35 U.S.C. § 154 and 173 of U.S. Patent No. 6,421,753, as presently shortened by terminal disclaimer, in the event that it later: expires for failure to pay a maintenance fee, is held unenforceable, is found invalid by a court of competent jurisdiction, is statutorily disclaimed in whole or terminally disclaimed under 37 C.F.R. 1.321, has all claims canceled by a reexamination certificate, is reissued, or is in any manner terminated prior to the expiration of its full statutory term as presently shortened by terminal disclaimer.

iii) The terminal part of the statutory term of any patent granted on the instant application, which would extend beyond the expiration date of the full statutory term defined in 35 U.S.C. § 154 and 173, as presently shortened by terminal disclaimer, of U.S. Patent No. 6,425,036. In making the above disclaimer, the owner does not disclaim the terminal part of any patent granted on the instant application that would extend to the expiration date of the full statutory term as defined in 35 U.S.C. § 154 and 173 of U.S. Patent No. 6,425,036, as presently shortened by terminal disclaimer, in the event that it later: expires for failure to pay a maintenance fee, is held unenforceable, is found invalid by a court of competent jurisdiction, is statutorily disclaimed in whole or terminally disclaimed under 37 C.F.R. 1.321, has all claims canceled by a reexamination certificate, is reissued, or is in any manner terminated prior to the expiration of its full statutory term, as presently shortened by any terminal disclaimer.

iv) The terminal part of the statutory term of any patent granted on the instant application, which would extend beyond the expiration date of the full statutory term defined in 35 U.S.C. § 154 and 173, as presently shortened by terminal disclaimer, of U.S. Patent No. 6,425,035. In making the above disclaimer, the owner does not disclaim the terminal part of any patent granted on the instant application that would extend to the expiration date of the full statutory term as defined in 35 U.S.C. § 154 and 173 of U.S. Patent No. 6,425,035, as presently shortened by terminal disclaimer, in the event that it later: expires for failure to pay a maintenance fee, is held unenforceable, is found invalid by a court of competent jurisdiction, is statutorily disclaimed in whole or terminally disclaimed under 37 C.F.R. 1.321, has all claims canceled by a reexamination certificate, is reissued, or is in any manner terminated prior to the expiration of its full statutory term, as presently shortened by any terminal disclaimer.

v) The terminal part of the statutory term of any patent granted on the instant application, which would extend beyond the expiration date of the full statutory term defined in 35 U.S.C. § 154 and 173, as presently shortened by terminal disclaimer, of U.S. Patent No. 6,789,152. In making the above disclaimer, the owner does not disclaim the terminal part of any patent granted on the instant application that would extend to the expiration date of the full statutory term as defined in 35 U.S.C. § 154 and 173 of U.S. Patent No. 6,789,152, as presently shortened by terminal disclaimer, in the event that it later: expires for failure to pay a maintenance fee, is held unenforceable, is found invalid by a court of competent jurisdiction, is statutorily disclaimed in whole or terminally disclaimed under 37 C.F.R. 1.321, has all claims canceled by a reexamination certificate, is reissued, or is in any manner terminated prior to the expiration of its full statutory term, as presently shortened by any terminal disclaimer.

vi) The terminal part of the statutory term of any patent granted on the instant application, which would extend beyond the expiration date of the full statutory term defined in 35 U.S.C. § 154 and 173, as presently shortened by terminal disclaimer, of U.S. Patent No. 6,738,854. In making the above disclaimer, the owner does not disclaim the terminal part of any patent granted on the instant application that would extend to the expiration date of the full statutory term as defined in 35 U.S.C. § 154 and 173 of U.S. Patent No. 6,738,854, as presently shortened by terminal disclaimer, in the event that it later: expires for failure to pay a maintenance fee, is held unenforceable, is found invalid by a court of competent jurisdiction, is statutorily disclaimed in whole or terminally disclaimed under 37 C.F.R. 1.321, has all claims canceled by a reexamination certificate, is reissued, or is in any manner terminated prior to the expiration of its full statutory term, as presently shortened by any terminal disclaimer.

vii) The terminal part of the statutory term of any patent granted on the instant application, which would extend beyond the expiration date of the full statutory term defined in 35 U.S.C. § 154 and 173, as presently shortened by terminal disclaimer, of U.S. Patent No. 6,763,419. In making the above disclaimer, the owner does not disclaim the terminal part of any patent granted on the instant application that would extend to the expiration date of the full statutory term as defined in 35 U.S.C. § 154 and 173 of U.S. Patent No. 6,763,419, as presently shortened by terminal disclaimer, in the event that it later: expires for failure to pay a maintenance fee, is held unenforceable, is found invalid by a court of competent jurisdiction, is statutorily disclaimed in whole or terminally disclaimed under 37 C.F.R. 1.321, has all claims canceled by

a reexamination certificate, is reissued, or is in any manner terminated prior to the expiration of its full statutory term, as presently shortened by any terminal disclaimer.

viii) The terminal part of the statutory term of any patent granted on the instant application, which would extend beyond the expiration date of the full statutory term defined in 35 U.S.C. § 154 and 173, as presently shortened by terminal disclaimer, of U.S. Patent No. 7,051,147. In making the above disclaimer, the owner does not disclaim the terminal part of any patent granted on the instant application that would extend to the expiration date of the full statutory term as defined in 35 U.S.C. § 154 and 173 of U.S. Patent No. 7,051,147, as presently shortened by terminal disclaimer, in the event that it later: expires for failure to pay a maintenance fee, is held unenforceable, is found invalid by a court of competent jurisdiction, is statutorily disclaimed in whole or terminally disclaimed under 37 C.F.R. 1.321, has all claims canceled by a reexamination certificate, is reissued, or is in any manner terminated prior to the expiration of its full statutory term, as presently shortened by any terminal disclaimer.

ix) The terminal part of the statutory term of any patent granted on the instant application, which would extend beyond the expiration date of the full statutory term defined in 35 U.S.C. § 154 and 173, as presently shortened by terminal disclaimer, of U.S. Patent No. 7,340,549. In making the above disclaimer, the owner does not disclaim the terminal part of any patent granted on the instant application that would extend to the expiration date of the full statutory term as defined in 35 U.S.C. § 154 and 173 of U.S. Patent No. 7,340,549, as presently shortened by terminal disclaimer, in the event that it later: expires for failure to pay a maintenance fee, is held unenforceable, is found invalid by a court of competent jurisdiction, is statutorily disclaimed in whole or terminally disclaimed under 37 C.F.R. 1.321, has all claims canceled by a reexamination certificate, is reissued, or is in any manner terminated prior to the expiration of its full statutory term, as presently shortened by any terminal disclaimer.

x) The terminal part of the statutory term of any patent granted on the instant application, which would extend beyond the expiration date of the full statutory term defined in 35 U.S.C. § 154 and 173, as presently shortened by terminal disclaimer, of U.S. Patent No. 7,689,754. In making the above disclaimer, the owner does not disclaim the terminal part of any patent granted on the instant application that would extend to the expiration date of the full statutory term as defined in 35 U.S.C. § 154 and 173 of U.S. Patent No. 7,689,754, as presently

shorted by terminal disclaimer, in the event that it later: expires for failure to pay a maintenance fee, is held unenforceable, is found invalid by a court of competent jurisdiction, is statutorily disclaimed in whole or terminally disclaimed under 37 C.F.R. 1.321, has all claims canceled by a reexamination certificate, is reissued, or is in any manner terminated prior to the expiration of its full statutory term, as presently shortened by any terminal disclaimer.

xi) The terminal part of the statutory term of any patent granted on the instant application, which would extend beyond the expiration date of the full statutory term defined in 35 U.S.C. § 154 and 173, as presently shortened by terminal disclaimer, of U.S. Patent No. 7,552,266. In making the above disclaimer, the owner does not disclaim the terminal part of any patent granted on the instant application that would extend to the expiration date of the full statutory term as defined in 35 U.S.C. § 154 and 173 of U.S. Patent No. 7,552,266, as presently shortened by terminal disclaimer, in the event that it later: expires for failure to pay a maintenance fee, is held unenforceable, is found invalid by a court of competent jurisdiction, is statutorily disclaimed in whole or terminally disclaimed under 37 C.F.R. 1.321, has all claims canceled by a reexamination certificate, is reissued, or is in any manner terminated prior to the expiration of its full statutory term, as presently shortened by any terminal disclaimer.

xii) The terminal part of the statutory term of any patent granted on the instant application, which would extend beyond the expiration date of the full statutory term defined in 35 U.S.C. § 154 and 173, as presently shortened by terminal disclaimer, of U.S. Patent No. 7,694,058. In making the above disclaimer, the owner does not disclaim the terminal part of any patent granted on the instant application that would extend to the expiration date of the full statutory term as defined in 35 U.S.C. § 154 and 173 of U.S. Patent No. 7,694,058, as presently shortened by terminal disclaimer, in the event that it later: expires for failure to pay a maintenance fee, is held unenforceable, is found invalid by a court of competent jurisdiction, is statutorily disclaimed in whole or terminally disclaimed under 37 C.F.R. 1.321, has all claims canceled by a reexamination certificate, is reissued, or is in any manner terminated prior to the expiration of its full statutory term, as presently shortened by any terminal disclaimer.

xiii) The terminal part of the statutory term of any patent granted on the instant application, which would extend beyond the expiration date of the full statutory term of any patent granted on United States Patent Application No. 11/947,499 as defined in 35 U.S.C.

§ 154 and 173 as shortened by any terminal disclaimer filed prior to the grant of any patent on United States Patent Application No. 11/947,499. In making the above disclaimer, the owner does not disclaim the terminal part of any patent granted on the instant application that would extend to the expiration date of the full term as defined in 35 U.S.C. § 154 and 173 as shortened by any terminal disclaimer filed prior to the grant of any patent on United States Patent Application No. 11/947,499, in the event that any such patent granted on the co-pending application: expires for failure to pay a maintenance fee, is held unenforceable, is found invalid by a court of competent jurisdiction, is statutorily disclaimed in whole or terminally disclaimed under 37 C.F.R. 1.321, has all claims canceled by a reexamination certificate, is reissued, or is in any manner terminated prior to the expiration of its full statutory term as shortened by any terminal disclaimer filed prior to its grant.

xiv) The terminal part of the statutory term of any patent granted on the instant application, which would extend beyond the expiration date of the full statutory term of any patent granted on United States Patent Application No. 12/220,431 as defined in 35 U.S.C. § 154 and 173 as shortened by any terminal disclaimer filed prior to the grant of any patent on United States Patent Application No. 12/220,431. In making the above disclaimer, the owner does not disclaim the terminal part of any patent granted on the instant application that would extend to the expiration date of the full term as defined in 35 U.S.C. § 154 and 173 as shortened by any terminal disclaimer filed prior to the grant of any patent on United States Patent Application No. 12/220,431, in the event that any such patent granted on the co-pending application: expires for failure to pay a maintenance fee, is held unenforceable, is found invalid by a court of competent jurisdiction, is statutorily disclaimed in whole or terminally disclaimed under 37 C.F.R. 1.321, has all claims canceled by a reexamination certificate, is reissued, or is in any manner terminated prior to the expiration of its full statutory term as shortened by any terminal disclaimer filed prior to its grant.

xv) The terminal part of the statutory term of any patent granted on the instant application, which would extend beyond the expiration date of the full statutory term of any patent granted on United States Patent Application No. 11/980,909 as defined in 35 U.S.C. § 154 and 173 as shortened by any terminal disclaimer filed prior to the grant of any patent on United States Patent Application No. 11/980,909. In making the above disclaimer, the owner does not disclaim the terminal part of any patent granted on the instant application that would

extend to the expiration date of the full term as defined in 35 U.S.C. § 154 and 173 as shortened by any terminal disclaimer filed prior to the grant of any patent on United States Patent Application No. 11/980,909, in the event that any such patent granted on the co-pending application: expires for failure to pay a maintenance fee, is held unenforceable, is found invalid by a court of competent jurisdiction, is statutorily disclaimed in whole or terminally disclaimed under 37 C.F.R. 1.321, has all claims canceled by a reexamination certificate, is reissued, or is in any manner terminated prior to the expiration of its full statutory term as shortened by any terminal disclaimer filed prior to its grant.

xvi) The terminal part of the statutory term of any patent granted on the instant application, which would extend beyond the expiration date of the full statutory term of any patent granted on United States Patent Application No. 12/552,885 as defined in 35 U.S.C. § 154 and 173 as shortened by any terminal disclaimer filed prior to the grant of any patent on United States Patent Application No. 12/552,885. In making the above disclaimer, the owner does not disclaim the terminal part of any patent granted on the instant application that would extend to the expiration date of the full term as defined in 35 U.S.C. § 154 and 173 as shortened by any terminal disclaimer filed prior to the grant of any patent on United States Patent Application No. 12/552,885, in the event that any such patent granted on the co-pending application: expires for failure to pay a maintenance fee, is held unenforceable, is found invalid by a court of competent jurisdiction, is statutorily disclaimed in whole or terminally disclaimed under 37 C.F.R. 1.321, has all claims canceled by a reexamination certificate, is reissued, or is in any manner terminated prior to the expiration of its full statutory term as shortened by any terminal disclaimer filed prior to its grant.

xvii) The terminal part of the statutory term of any patent granted on the instant application, which would extend beyond the expiration date of the full statutory term of any patent granted on United States Patent Application No. 12/552,913 as defined in 35 U.S.C. § 154 and 173 as shortened by any terminal disclaimer filed prior to the grant of any patent on United States Patent Application No. 12/552,913. In making the above disclaimer, the owner does not disclaim the terminal part of any patent granted on the instant application that would extend to the expiration date of the full term as defined in 35 U.S.C. § 154 and 173 as shortened by any terminal disclaimer filed prior to the grant of any patent on United States Patent Application No. 12/552,913, in the event that any such patent granted on the co-pending

application: expires for failure to pay a maintenance fee, is held unenforceable, is found invalid by a court of competent jurisdiction, is statutorily disclaimed in whole or terminally disclaimed under 37 C.F.R. 1.321, has all claims canceled by a reexamination certificate, is reissued, or is in any manner terminated prior to the expiration of its full statutory term as shortened by any terminal disclaimer filed prior to its grant.

xviii) The terminal part of the statutory term of any patent granted on the instant application, which would extend beyond the expiration date of the full statutory term of any patent granted on United States Patent Application No. 12/552,807 as defined in 35 U.S.C. § 154 and 173 as shortened by any terminal disclaimer filed prior to the grant of any patent on United States Patent Application No. 12/552,807. In making the above disclaimer, the owner does not disclaim the terminal part of any patent granted on the instant application that would extend to the expiration date of the full term as defined in 35 U.S.C. § 154 and 173 as shortened by any terminal disclaimer filed prior to the grant of any patent on United States Patent Application No. 12/552,807, in the event that any such patent granted on the co-pending application: expires for failure to pay a maintenance fee, is held unenforceable, is found invalid by a court of competent jurisdiction, is statutorily disclaimed in whole or terminally disclaimed under 37 C.F.R. 1.321, has all claims canceled by a reexamination certificate, is reissued, or is in any manner terminated prior to the expiration of its full statutory term as shortened by any terminal disclaimer filed prior to its grant.

xix) The terminal part of the statutory term of any patent granted on the instant application, which would extend beyond the expiration date of the full statutory term of any patent granted on United States Patent Application No. 12/910,375 as defined in 35 U.S.C. § 154 and 173 as shortened by any terminal disclaimer filed prior to the grant of any patent on United States Patent Application No. 12/910,375. In making the above disclaimer, the owner does not disclaim the terminal part of any patent granted on the instant application that would extend to the expiration date of the full term as defined in 35 U.S.C. § 154 and 173 as shortened by any terminal disclaimer filed prior to the grant of any patent on United States Patent Application No. 12/910,375, in the event that any such patent granted on the co-pending application: expires for failure to pay a maintenance fee, is held unenforceable, is found invalid by a court of competent jurisdiction, is statutorily disclaimed in whole or terminally disclaimed under 37 C.F.R. 1.321, has all claims canceled by a reexamination certificate, is reissued, or is

in any manner terminated prior to the expiration of its full statutory term as shortened by any terminal disclaimer filed prior to its grant

xx) The terminal part of the statutory term of any patent granted on the instant application, which would extend beyond the expiration date of the full statutory term of any patent granted on United States Patent Application No. 12/910,431 as defined in 35 U.S.C. § 154 and 173 as shortened by any terminal disclaimer filed prior to the grant of any patent on United States Patent Application No. 12/910,431. In making the above disclaimer, the owner does not disclaim the terminal part of any patent granted on the instant application that would extend to the expiration date of the full term as defined in 35 U.S.C. § 154 and 173 as shortened by any terminal disclaimer filed prior to the grant of any patent on United States Patent Application No. 12/910,431, in the event that any such patent granted on the co-pending application: expires for failure to pay a maintenance fee, is held unenforceable, is found invalid by a court of competent jurisdiction, is statutorily disclaimed in whole or terminally disclaimed under 37 C.F.R. 1.321, has all claims canceled by a reexamination certificate, is reissued, or is in any manner terminated prior to the expiration of its full statutory term as shortened by any terminal disclaimer filed prior to its grant.

xxi) The terminal part of the statutory term of any patent granted on the instant application, which would extend beyond the expiration date of the full statutory term of any patent granted on United States Patent Application No. 12/910,476 as defined in 35 U.S.C. § 154 and 173 as shortened by any terminal disclaimer filed prior to the grant of any patent on United States Patent Application No. 12/910,476. In making the above disclaimer, the owner does not disclaim the terminal part of any patent granted on the instant application that would extend to the expiration date of the full term as defined in 35 U.S.C. § 154 and 173 as shortened by any terminal disclaimer filed prior to the grant of any patent on United States Patent Application No. 12/910,476, in the event that any such patent granted on the co-pending application: expires for failure to pay a maintenance fee, is held unenforceable, is found invalid by a court of competent jurisdiction, is statutorily disclaimed in whole or terminally disclaimed under 37 C.F.R. 1.321, has all claims canceled by a reexamination certificate, is reissued, or is in any manner terminated prior to the expiration of its full statutory term as shortened by any terminal disclaimer filed prior to its grant

xxii) The terminal part of the statutory term of any patent granted on the instant application, which would extend beyond the expiration date of the full statutory term of any patent granted on United States Patent Application No. 12/910,515 as defined in 35 U.S.C. § 154 and 173 as shortened by any terminal disclaimer filed prior to the grant of any patent on United States Patent Application No. 12/910,515. In making the above disclaimer, the owner does not disclaim the terminal part of any patent granted on the instant application that would extend to the expiration date of the full term as defined in 35 U.S.C. § 154 and 173 as shortened by any terminal disclaimer filed prior to the grant of any patent on United States Patent Application No. 12/910,515, in the event that any such patent granted on the co-pending application: expires for failure to pay a maintenance fee, is held unenforceable, is found invalid by a court of competent jurisdiction, is statutorily disclaimed in whole or terminally disclaimed under 37 C.F.R. 1.321, has all claims canceled by a reexamination certificate, is reissued, or is in any manner terminated prior to the expiration of its full statutory term as shortened by any terminal disclaimer filed prior to its grant

The owner hereby agrees that any patent so granted on the instant application shall be enforceable only for and during such period that it, the above-referenced patents and the above-referenced co-pending applications are commonly owned. This agreement runs with any patent granted on the instant application and is binding upon the grantee, its successors or assigns.

Check box 1, 2, 3, or 4 as appropriate.

1. For submission on behalf of an organization (e.g., corporation, partnership, university, government agency, etc.), the undersigned is empowered to act on behalf of the organization.

I hereby declare that all statements made herein of my own knowledge are true and that all statements made on information and belief are believed to be true; and further that these statements were made with the knowledge that willful false statements and the like so made are punishable by fine or imprisonment, or both, under Section 1001 of Title 18 of the United States Code and that such willful false statements may jeopardize the validity of the application or any patent issued thereon.

- * Statement under 37 C.R.F. 3.73(b) is required if terminal disclaimer is signed by the assignee (owner). Form PTO/SB/96 may be used for making this certification. See MPEP § 324.

2. The undersigned is an attorney or agent of record.
3. Terminal disclaimer fee under 37 C.F.R. 1.20(d) included.
4. Terminal disclaimer fee under 37 C.F.R. 1.20(d). The Commissioner is hereby authorized to deduct \$130.00 representing the above-noted filing fee from Deposit Account. No. 50-3183 of Sprinkle IP Law Group. The Commissioner is hereby further authorized to deduct any deficiencies or credit any overpayments regarding this application from the same account.



John L. Adair
Reg. No. 48,828

12-10-10
Dated

Electronic Patent Application Fee Transmittal

Application Number:	12690592			
Filing Date:	20-Jan-2010			
Title of Invention:	STORAGE ROUTER AND METHOD FOR PROVIDING VIRTUAL LOCAL STORAGE			
First Named Inventor/Applicant Name:	Geoffrey B. Hoese			
Filer:	John L. Adair/Delia Narvaiz			
Attorney Docket Number:	CROSS1120-33			
Filed as Large Entity				
Utility under 35 USC 111 (a) Filing Fees				
Description	Fee Code	Quantity	Amount	Sub-Total in USD(\$)
Basic Filing:				
Pages:				
Claims:				
Miscellaneous-Filing:				
Petition:				
Patent-Appeals-and-Interference:				
Post-Allowance-and-Post-Issuance:				
Extension-of-Time:				

Description	Fee Code	Quantity	Amount	Sub-Total in USD(\$)
Miscellaneous:				
Statutory or terminal disclaimer	1814	1	140	140
Total in USD (\$)				140

Electronic Acknowledgement Receipt

EFS ID:	9010738
Application Number:	12690592
International Application Number:	
Confirmation Number:	8115
Title of Invention:	STORAGE ROUTER AND METHOD FOR PROVIDING VIRTUAL LOCAL STORAGE
First Named Inventor/Applicant Name:	Geoffrey B. Hoese
Customer Number:	44654
Filer:	John L. Adair/Delia Narvaiz
Filer Authorized By:	John L. Adair
Attorney Docket Number:	CROSS1120-33
Receipt Date:	10-DEC-2010
Filing Date:	20-JAN-2010
Time Stamp:	15:14:59
Application Type:	Utility under 35 USC 111(a)

Payment information:

Submitted with Payment	yes
Payment Type	Deposit Account
Payment was successfully received in RAM	\$ 140
RAM confirmation Number	1520
Deposit Account	503183
Authorized User	

The Director of the USPTO is hereby authorized to charge indicated fees and credit any overpayment as follows:

Charge any Additional Fees required under 37 C.F.R. Section 1.16 (National application filing, search, and examination fees)

Charge any Additional Fees required under 37 C.F.R. Section 1.17 (Patent application and reexamination processing fees)

Charge any Additional Fees required under 37 C.F.R. Section 1.19 (Document supply fees)
 Charge any Additional Fees required under 37 C.F.R. Section 1.20 (Post Issuance fees)
 Charge any Additional Fees required under 37 C.F.R. Section 1.21 (Miscellaneous fees and charges)

File Listing:

Document Number	Document Description	File Name	File Size(Bytes)/ Message Digest	Multi Part /.zip	Pages (if appl.)
1		CROSS1120-33_ROA_121010.pdf	537418 6e59822f222b7f7497f1f7d6964bbad6891b63029	yes	14
Multipart Description/PDF files in .zip description					
	Document Description		Start		End
	Amendment/Req. Reconsideration-After Non-Final Reject		1		1
	Specification		2		2
	Claims		3		10
	Applicant summary of interview with examiner		11		12
	Applicant Arguments/Remarks Made in an Amendment		13		14
Warnings:					
Information:					
2	Terminal Disclaimer Filed	CROSS1120-33_TD.pdf	616456 66a9e07300ed52edbf6d6c196cff077829d7245	no	11
Warnings:					
Information:					
3	Fee Worksheet (PTO-875)	fee-info.pdf	30397 2ccb2d240efe13efa583b68a4c5d6a2d45cfcd56	no	2
Warnings:					
Information:					
Total Files Size (in bytes):			1184271		

This Acknowledgement Receipt evidences receipt on the noted date by the USPTO of the indicated documents, characterized by the applicant, and including page counts, where applicable. It serves as evidence of receipt similar to a Post Card, as described in MPEP 503.

New Applications Under 35 U.S.C. 111

If a new application is being filed and the application includes the necessary components for a filing date (see 37 CFR 1.53(b)-(d) and MPEP 506), a Filing Receipt (37 CFR 1.54) will be issued in due course and the date shown on this Acknowledgement Receipt will establish the filing date of the application.

National Stage of an International Application under 35 U.S.C. 371

If a timely submission to enter the national stage of an international application is compliant with the conditions of 35 U.S.C. 371 and other applicable requirements a Form PCT/DO/EO/903 indicating acceptance of the application as a national stage submission under 35 U.S.C. 371 will be issued in addition to the Filing Receipt, in due course.

New International Application Filed with the USPTO as a Receiving Office

If a new international application is being filed and the international application includes the necessary components for an international filing date (see PCT Article 11 and MPEP 1810), a Notification of the International Application Number and of the International Filing Date (Form PCT/RO/105) will be issued in due course, subject to prescriptions concerning national security, and the date shown on this Acknowledgement Receipt will establish the international filing date of the application.

INFORMATION DISCLOSURE STATEMENT				Application Number	12/690,592
				Filing or 371 (c) Date:	January 20, 2010
				First Named Inventor	Geoffrey B. Hoese
				Group Art Unit	2182
				Examiner Name	Unknown
Sheet	1	of	1	Atty Docket Number	CROSS1120-33
NON PATENT LITERATURE DOCUMENTS					
Examiner Initials	Cite No.	Include name of the author (in CAPITAL LETTERS), title of the article (when appropriate), title of the item (book, magazine, journal, serial, symposium, catalog, etc.) date, page(s), volume-issue number(s), publisher, city and/or country where published			T²
	C174	Office Action Mailed 09/13/10 in U.S. Serial No. 11/980,909			09/13/10
	C175	Office Action Mailed 09/13/10 in U.S. Serial No. 12/552,807			09/13/10
	C176	Office Action Mailed 09/15/10 in U.S. Serial No. 12/552,885			09/15/10
	C177	Office Action Mailed 09/23/10 in U.S. Serial No. 12/552,913			09/23/10
Examiner Signature				Date Considered	

Electronic Patent Application Fee Transmittal

Application Number:	12690592			
Filing Date:	20-Jan-2010			
Title of Invention:	STORAGE ROUTER AND METHOD FOR PROVIDING VIRTUAL LOCAL STORAGE			
First Named Inventor/Applicant Name:	Geoffrey B. Hoese			
Filer:	John L. Adair/Delia Narvaiz			
Attorney Docket Number:	CROSS1120-33			
Filed as Large Entity				
Utility under 35 USC 111 (a) Filing Fees				
Description	Fee Code	Quantity	Amount	Sub-Total in USD(\$)
Basic Filing:				
Pages:				
Claims:				
Miscellaneous-Filing:				
Petition:				
Patent-Appeals-and-Interference:				
Post-Allowance-and-Post-Issuance:				
Extension-of-Time:				

Description	Fee Code	Quantity	Amount	Sub-Total in USD(\$)
Miscellaneous:				
Submission- Information Disclosure Stmt	1806	1	180	180
Total in USD (\$)				180

Electronic Acknowledgement Receipt

EFS ID:	9013238
Application Number:	12690592
International Application Number:	
Confirmation Number:	8115
Title of Invention:	STORAGE ROUTER AND METHOD FOR PROVIDING VIRTUAL LOCAL STORAGE
First Named Inventor/Applicant Name:	Geoffrey B. Hoese
Customer Number:	44654
Filer:	John L. Adair/Delia Narvaiz
Filer Authorized By:	John L. Adair
Attorney Docket Number:	CROSS1120-33
Receipt Date:	10-DEC-2010
Filing Date:	20-JAN-2010
Time Stamp:	16:54:55
Application Type:	Utility under 35 USC 111(a)

Payment information:

Submitted with Payment	yes
Payment Type	Deposit Account
Payment was successfully received in RAM	\$ 180
RAM confirmation Number	3549
Deposit Account	503183
Authorized User	

The Director of the USPTO is hereby authorized to charge indicated fees and credit any overpayment as follows:

Charge any Additional Fees required under 37 C.F.R. Section 1.16 (National application filing, search, and examination fees)

Charge any Additional Fees required under 37 C.F.R. Section 1.17 (Patent application and reexamination processing fees)

Charge any Additional Fees required under 37 C.F.R. Section 1.19 (Document supply fees)
 Charge any Additional Fees required under 37 C.F.R. Section 1.20 (Post Issuance fees)
 Charge any Additional Fees required under 37 C.F.R. Section 1.21 (Miscellaneous fees and charges)

File Listing:

Document Number	Document Description	File Name	File Size(Bytes)/ Message Digest	Multi Part /.zip	Pages (if appl.)
1		CROSS1120-33_IDS_121010.pdf	118713 b9af1228e38ca950f0fd60b2fb2fc207db61d73	yes	3
Multipart Description/PDF files in .zip description					
	Document Description		Start		End
	Transmittal Letter		1		2
	Information Disclosure Statement (IDS) Filed (SB/08)		3		3
Warnings:					
Information:					
2	NPL Documents	CROSS1120_Ref_C174.pdf	164812 5039095bedf7274716acdd9b4726e1ccedcb4ca	no	7
Warnings:					
Information:					
3	NPL Documents	CROSS1120_Ref_C175.pdf	163965 8fcd974da4623a8ebc94e62a091e0e52cc0c2cd	no	7
Warnings:					
Information:					
4	NPL Documents	CROSS1120_Ref_C176.pdf	165757 21708767ba58acd885ba1bd417d71084fd0c1459	no	7
Warnings:					
Information:					
5	NPL Documents	CROSS1120_Ref_C177.pdf	166395 aa9f5ef1eb835af156987ab4f354fe60a206ba1	no	7
Warnings:					
Information:					
6	Fee Worksheet (PTO-875)	fee-info.pdf	30513 8e4cf3ec5a4643d4172cc328ca8997c2447b57d1	no	2
Warnings:					
Information:					
Total Files Size (in bytes):			810155		

This Acknowledgement Receipt evidences receipt on the noted date by the USPTO of the indicated documents, characterized by the applicant, and including page counts, where applicable. It serves as evidence of receipt similar to a Post Card, as described in MPEP 503.

New Applications Under 35 U.S.C. 111

If a new application is being filed and the application includes the necessary components for a filing date (see 37 CFR 1.53(b)-(d) and MPEP 506), a Filing Receipt (37 CFR 1.54) will be issued in due course and the date shown on this Acknowledgement Receipt will establish the filing date of the application.

National Stage of an International Application under 35 U.S.C. 371

If a timely submission to enter the national stage of an international application is compliant with the conditions of 35 U.S.C. 371 and other applicable requirements a Form PCT/DO/EO/903 indicating acceptance of the application as a national stage submission under 35 U.S.C. 371 will be issued in addition to the Filing Receipt, in due course.

New International Application Filed with the USPTO as a Receiving Office

If a new international application is being filed and the international application includes the necessary components for an international filing date (see PCT Article 11 and MPEP 1810), a Notification of the International Application Number and of the International Filing Date (Form PCT/RO/105) will be issued in due course, subject to prescriptions concerning national security, and the date shown on this Acknowledgement Receipt will establish the international filing date of the application.

IN THE UNITED STATES PATENT AND TRADEMARK OFFICE	
INFORMATION DISCLOSURE STATEMENT BY APPLICANT	Atty. Docket No. (Opt.) CROSS1120-33
Applicant Geoffrey B. Hoese	
Application Number 12/690,592	Filing or 371 (c) Date: January 20, 2010
For STORAGE ROUTER AND METHOD FOR PROVIDING VIRTUAL LOCAL STORAGE	
Group Art Unit 2181	Examiner Shin, Christopher
Confirmation Number: 8115	

Commissioner for Patents
P.O. Box 1450
Alexandria, VA 22313-1450

Dear Sir,

<u>Certification of Transmission Under 37 C.F.R. 1.8</u>
I hereby certify that this correspondence is being transmitted to the Commissioner for Patents, P.O. Box 1450, Alexandria, VA 22312-1450 via the U.S. Patent and Trademark Office Electronic Filing System (EFS-Web) on December 10, 2010 .
 Delia Narvaiz

Applicant respectfully requests, pursuant to 37 C.F.R. §§ 1.56, 1.97 and 1.98, that the information listed on the attached SB08A/B form(s) be considered and cited in the examination of the above-identified application. A copy of U.S. Patent(s) and U.S. Patent Application Publication(s) listed on the attached SB08A form is not being submitted with this Information Disclosure Statement pursuant to the waiver of 37 C.F.R. § 1.98(a)(2)(i) by the U.S. Patent and Trademark Office. A copy of foreign patent documents as well as the information listed on the attached SB08B form is enclosed for the convenience of the Examiner.

This Information Disclosure Statement is being submitted within three months of the filing date of a national application other than a continued prosecution application under 37 C.F.R. § 1.53(d).

This Information Disclosure Statement is being submitted within three months of the date of entry of the national stage as set forth in 37 C.F.R. § 1.491 in an international application;

This Information Disclosure Statement is being submitted before the mailing of a first Office action on the merits; or

This Information Disclosure Statement is being submitted before the mailing of a first Office action after the filing of a request for continued examination under 37 C.F.R. § 1.114.

This Information Disclosure Statement is being submitted after the period specified in 37 C.F.R. § 1.97(b) and before the mailing date of any of a final action under 37 C.F.R. § 1.113, a notice of allowance under 37 C.F.R. § 1.311, or an action that otherwise closes prosecution in the application, and is accompanied by one of:

- The statement specified in 37 C.F.R. § 1.97(e); or
- The fee set forth in 37 C.F.R. § 1.17(p). Applicant hereby authorizes the Commissioner to deduct the amount of \$180 from Deposit Account No. 50-3183 of Sprinkle IP Law Group for the filing fee of this Information Disclosure Statement.

This Information Disclosure Statement is being submitted after the period specified in 37 C.F.R. § 1.97(c) and on or before payment of the issue fee and is accompanied by:

- The statement specified in 37 C.F.R. § 1.97(e); and
- The fee set forth in 37 C.F.R. § 1.17(p). Applicant hereby authorizes the Commissioner to deduct the amount of \$180 from Deposit Account No. 50-3183 of Sprinkle IP Law Group for the filing fee of this Information Disclosure Statement.

Applicant does not believe any fees are due for filing this Information Disclosure Statement; however, if Applicant is in error, the Director is hereby authorized to deduct any and all appropriate fees from Deposit Account 50-3183 of Sprinkle IP Law Group. Applicant respectfully submits that the claims of Applicant's above-referenced patent application are patentably distinguishable from the listed information.

Respectfully submitted,

Sprinkle IP Law Group
Attorneys for Applicant

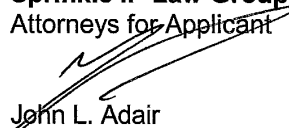
John L. Adair
Reg. No. 48,828

Dated: December 10, 2010

1301 W. 25th Street, Suite 408
Austin, Texas 78705
Tel. (512) 637-9220
Fax. (512) 317-9088

Under the Paperwork Reduction Act of 1995, no persons are required to respond to a collection of information unless it displays a valid OMB control number.

PATENT APPLICATION FEE DETERMINATION RECORD Substitute for Form PTO-875					Application or Docket Number 12/690,592	Filing Date 01/20/2010	<input type="checkbox"/> To be Mailed			
APPLICATION AS FILED – PART I					OTHER THAN					
(Column 1)		(Column 2)		SMALL ENTITY <input type="checkbox"/>		OR SMALL ENTITY				
FOR	NUMBER FILED	NUMBER EXTRA		RATE (\$)	FEE (\$)	RATE (\$)	FEE (\$)			
<input type="checkbox"/> BASIC FEE <small>(37 CFR 1.16(a), (b), or (c))</small>	N/A	N/A		N/A		N/A				
<input type="checkbox"/> SEARCH FEE <small>(37 CFR 1.16(k), (l), or (m))</small>	N/A	N/A		N/A		N/A				
<input type="checkbox"/> EXAMINATION FEE <small>(37 CFR 1.16(o), (p), or (q))</small>	N/A	N/A		N/A		N/A				
TOTAL CLAIMS <small>(37 CFR 1.16(i))</small>	minus 20 =	*		X \$ =		X \$ =				
INDEPENDENT CLAIMS <small>(37 CFR 1.16(h))</small>	minus 3 =	*		X \$ =		X \$ =				
<input type="checkbox"/> APPLICATION SIZE FEE <small>(37 CFR 1.16(s))</small>	If the specification and drawings exceed 100 sheets of paper, the application size fee due is \$250 (\$125 for small entity) for each additional 50 sheets or fraction thereof. See 35 U.S.C. 41(a)(1)(G) and 37 CFR 1.16(s).									
<input type="checkbox"/> MULTIPLE DEPENDENT CLAIM PRESENT <small>(37 CFR 1.16(j))</small>										
* If the difference in column 1 is less than zero, enter "0" in column 2.										
APPLICATION AS AMENDED – PART II					OTHER THAN					
(Column 1)		(Column 2)		SMALL ENTITY		OR SMALL ENTITY				
AMENDMENT	12/10/2010	CLAIMS REMAINING AFTER AMENDMENT		HIGHEST NUMBER PREVIOUSLY PAID FOR	PRESENT EXTRA	RATE (\$)	ADDITIONAL FEE (\$)	RATE (\$)	ADDITIONAL FEE (\$)	
	Total <small>(37 CFR 1.16(i))</small>	* 53	Minus	** 53	= 0	X \$ =		OR X \$52=	0	
	Independent <small>(37 CFR 1.16(h))</small>	* 3	Minus	***3	= 0	X \$ =		OR X \$220=	0	
	<input type="checkbox"/> Application Size Fee <small>(37 CFR 1.16(s))</small>									
	<input type="checkbox"/> FIRST PRESENTATION OF MULTIPLE DEPENDENT CLAIM <small>(37 CFR 1.16(j))</small>									
						TOTAL ADD'L FEE		OR TOTAL ADD'L FEE	0	
(Column 1)		(Column 2)		(Column 3)		SMALL ENTITY		OR SMALL ENTITY		
AMENDMENT		CLAIMS REMAINING AFTER AMENDMENT		HIGHEST NUMBER PREVIOUSLY PAID FOR	PRESENT EXTRA	RATE (\$)	ADDITIONAL FEE (\$)	RATE (\$)	ADDITIONAL FEE (\$)	
	Total <small>(37 CFR 1.16(i))</small>	*	Minus	**	=	X \$ =		OR X \$ =		
	Independent <small>(37 CFR 1.16(h))</small>	*	Minus	***	=	X \$ =		OR X \$ =		
	<input type="checkbox"/> Application Size Fee <small>(37 CFR 1.16(s))</small>									
	<input type="checkbox"/> FIRST PRESENTATION OF MULTIPLE DEPENDENT CLAIM <small>(37 CFR 1.16(j))</small>									
						TOTAL ADD'L FEE		OR TOTAL ADD'L FEE		
* If the entry in column 1 is less than the entry in column 2, write "0" in column 3.										
** If the "Highest Number Previously Paid For" IN THIS SPACE is less than 20, enter "20".										
*** If the "Highest Number Previously Paid For" IN THIS SPACE is less than 3, enter "3".										
The "Highest Number Previously Paid For" (Total or Independent) is the highest number found in the appropriate box in column 1.										
Legal Instrument Examiner: /MARQUITA D. JONES/										

This collection of information is required by 37 CFR 1.16. The information is required to obtain or retain a benefit by the public which is to file (and by the USPTO to process) an application. Confidentiality is governed by 35 U.S.C. 122 and 37 CFR 1.14. This collection is estimated to take 12 minutes to complete, including gathering, preparing, and submitting the completed application form to the USPTO. Time will vary depending upon the individual case. Any comments on the amount of time you require to complete this form and/or suggestions for reducing this burden, should be sent to the Chief Information Officer, U.S. Patent and Trademark Office, U.S. Department of Commerce, P.O. Box 1450, Alexandria, VA 22313-1450. DO NOT SEND FEES OR COMPLETED FORMS TO THIS ADDRESS. **SEND TO: Commissioner for Patents, P.O. Box 1450, Alexandria, VA 22313-1450.**

If you need assistance in completing the form, call 1-800-PTO-9199 and select option 2.



UNITED STATES PATENT AND TRADEMARK OFFICE

UNITED STATES DEPARTMENT OF COMMERCE
United States Patent and Trademark Office
Address: COMMISSIONER FOR PATENTS
P.O. Box 1450
Alexandria, Virginia 22313-1450
www.uspto.gov

APPLICATION NO.	FILING DATE	FIRST NAMED INVENTOR	ATTORNEY DOCKET NO.	CONFIRMATION NO.
12/690,592	01/20/2010	Geoffrey B. Hoese	CROSS1120-33	8115

44654 7590 09/10/2010
SPRINKLE IP LAW GROUP
1301 W. 25TH STREET
SUITE 408
AUSTIN, TX 78705

EXAMINER

SHIN, CHRISTOPHER B

ART UNIT PAPER NUMBER

2181

MAIL DATE DELIVERY MODE

09/10/2010

PAPER

Please find below and/or attached an Office communication concerning this application or proceeding.

The time period for reply, if any, is set in the attached communication.

Interview Summary	Application No. 12/690,592	Applicant(s) HOESE ET AL.	
	Examiner Christopher B. Shin	Art Unit 2181	

All participants (applicant, applicant's representative, PTO personnel):

(1) Christopher B. Shin. (3)_____.

(2) John L. Adair. (4)_____.

Date of Interview: 30 August 2010.

Type: a) Telephonic b) Video Conference
c) Personal [copy given to: 1) applicant 2) applicant's representative]

Exhibit shown or demonstration conducted: d) Yes e) No.
If Yes, brief description: _____.

Claim(s) discussed: 1-53.

Identification of prior art discussed: _____.

Agreement with respect to the claims f) was reached. g) was not reached. h) N/A.

Substance of Interview including description of the general nature of what was agreed to if an agreement was reached, or any other comments: In order to move the case in condition for allowance & to be consistent with the all of the related/parent cases/specification, the applicant agreed to amend the claims to clearly recite that the claimed mediums (i.e., the first and second medims) are not the same mediums, but the protocols used on such mediums can be the same or different protocol types. Therefore, the native low level block protocols are used between different mediums that may use the same or different protocol types is consistent with the related cases and specification. In other words, one of the medium is remote, separate & different from the other medium.. The applicant also agreed to amend & update the RELATED APPLICATIONS of the specification; & the applicant agreed to file Terminal Disclaimer against all of the Related Applications.

(A fuller description, if necessary, and a copy of the amendments which the examiner agreed would render the claims allowable, if available, must be attached. Also, where no copy of the amendments that would render the claims allowable is available, a summary thereof must be attached.)

THE FORMAL WRITTEN REPLY TO THE LAST OFFICE ACTION MUST INCLUDE THE SUBSTANCE OF THE INTERVIEW. (See MPEP Section 713.04). If a reply to the last Office action has already been filed, APPLICANT IS GIVEN A NON-EXTENDABLE PERIOD OF THE LONGER OF ONE MONTH OR THIRTY DAYS FROM THIS INTERVIEW DATE, OR THE MAILING DATE OF THIS INTERVIEW SUMMARY FORM, WHICHEVER IS LATER, TO FILE A STATEMENT OF THE SUBSTANCE OF THE INTERVIEW. See Summary of Record of Interview requirements on reverse side or on attached sheet.

	/Christopher B Shin/ Primary Examiner, Art Unit 2181
--	---------------------------------------------------------

Summary of Record of Interview Requirements

Manual of Patent Examining Procedure (MPEP), Section 713.04, Substance of Interview Must be Made of Record

A complete written statement as to the substance of any face-to-face, video conference, or telephone interview with regard to an application must be made of record in the application whether or not an agreement with the examiner was reached at the interview.

Title 37 Code of Federal Regulations (CFR) § 1.133 Interviews Paragraph (b)

In every instance where reconsideration is requested in view of an interview with an examiner, a complete written statement of the reasons presented at the interview as warranting favorable action must be filed by the applicant. An interview does not remove the necessity for reply to Office action as specified in §§ 1.111, 1.135. (35 U.S.C. 132)

37 CFR §1.2 Business to be transacted in writing.

All business with the Patent or Trademark Office should be transacted in writing. The personal attendance of applicants or their attorneys or agents at the Patent and Trademark Office is unnecessary. The action of the Patent and Trademark Office will be based exclusively on the written record in the Office. No attention will be paid to any alleged oral promise, stipulation, or understanding in relation to which there is disagreement or doubt.

The action of the Patent and Trademark Office cannot be based exclusively on the written record in the Office if that record is itself incomplete through the failure to record the substance of interviews.

It is the responsibility of the applicant or the attorney or agent to make the substance of an interview of record in the application file, unless the examiner indicates he or she will do so. It is the examiner's responsibility to see that such a record is made and to correct material inaccuracies which bear directly on the question of patentability.

Examiners must complete an Interview Summary Form for each interview held where a matter of substance has been discussed during the interview by checking the appropriate boxes and filling in the blanks. Discussions regarding only procedural matters, directed solely to restriction requirements for which interview recordation is otherwise provided for in Section 812.01 of the Manual of Patent Examining Procedure, or pointing out typographical errors or unreadable script in Office actions or the like, are excluded from the interview recordation procedures below. Where the substance of an interview is completely recorded in an Examiners Amendment, no separate Interview Summary Record is required.

The Interview Summary Form shall be given an appropriate Paper No., placed in the right hand portion of the file, and listed on the "Contents" section of the file wrapper. In a personal interview, a duplicate of the Form is given to the applicant (or attorney or agent) at the conclusion of the interview. In the case of a telephone or video-conference interview, the copy is mailed to the applicant's correspondence address either with or prior to the next official communication. If additional correspondence from the examiner is not likely before an allowance or if other circumstances dictate, the Form should be mailed promptly after the interview rather than with the next official communication.

The Form provides for recordation of the following information:

- Application Number (Series Code and Serial Number)
- Name of applicant
- Name of examiner
- Date of interview
- Type of interview (telephonic, video-conference, or personal)
- Name of participant(s) (applicant, attorney or agent, examiner, other PTO personnel, etc.)
- An indication whether or not an exhibit was shown or a demonstration conducted
- An identification of the specific prior art discussed
- An indication whether an agreement was reached and if so, a description of the general nature of the agreement (may be by attachment of a copy of amendments or claims agreed as being allowable). Note: Agreement as to allowability is tentative and does not restrict further action by the examiner to the contrary.
- The signature of the examiner who conducted the interview (if Form is not an attachment to a signed Office action)

It is desirable that the examiner orally remind the applicant of his or her obligation to record the substance of the interview of each case. It should be noted, however, that the Interview Summary Form will not normally be considered a complete and proper recordation of the interview unless it includes, or is supplemented by the applicant or the examiner to include, all of the applicable items required below concerning the substance of the interview.

A complete and proper recordation of the substance of any interview should include at least the following applicable items:

- 1) A brief description of the nature of any exhibit shown or any demonstration conducted,
- 2) an identification of the claims discussed,
- 3) an identification of the specific prior art discussed,
- 4) an identification of the principal proposed amendments of a substantive nature discussed, unless these are already described on the Interview Summary Form completed by the Examiner,
- 5) a brief identification of the general thrust of the principal arguments presented to the examiner,
(The identification of arguments need not be lengthy or elaborate. A verbatim or highly detailed description of the arguments is not required. The identification of the arguments is sufficient if the general nature or thrust of the principal arguments made to the examiner can be understood in the context of the application file. Of course, the applicant may desire to emphasize and fully describe those arguments which he or she feels were or might be persuasive to the examiner.)
- 6) a general indication of any other pertinent matters discussed, and
- 7) if appropriate, the general results or outcome of the interview unless already described in the Interview Summary Form completed by the examiner.

Examiners are expected to carefully review the applicant's record of the substance of an interview. If the record is not complete and accurate, the examiner will give the applicant an extendable one month time period to correct the record.

Examiner to Check for Accuracy

If the claims are allowable for other reasons of record, the examiner should send a letter setting forth the examiner's version of the statement attributed to him or her. If the record is complete and accurate, the examiner should place the indication, "Interview Record OK" on the paper recording the substance of the interview along with the date and the examiner's initials.



UNITED STATES PATENT AND TRADEMARK OFFICE

UNITED STATES DEPARTMENT OF COMMERCE
United States Patent and Trademark Office
Address: COMMISSIONER FOR PATENTS
P.O. Box 1450
Alexandria, Virginia 22313-1450
www.uspto.gov

APPLICATION NO.	FILING DATE	FIRST NAMED INVENTOR	ATTORNEY DOCKET NO.	CONFIRMATION NO.
12/690,592	01/20/2010	Geoffrey B. Hoese	CROSS1120-33	8115

44654 7590 09/10/2010
SPRINKLE IP LAW GROUP
1301 W. 25TH STREET
SUITE 408
AUSTIN, TX 78705

EXAMINER

SHIN, CHRISTOPHER B

ART UNIT PAPER NUMBER

2181

MAIL DATE DELIVERY MODE

09/10/2010

PAPER

Please find below and/or attached an Office communication concerning this application or proceeding.

The time period for reply, if any, is set in the attached communication.

Office Action Summary	Application No. 12/690,592	Applicant(s) HOESE ET AL.	
	Examiner Christopher B. Shin	Art Unit 2181	

-- The MAILING DATE of this communication appears on the cover sheet with the correspondence address --

Period for Reply

A SHORTENED STATUTORY PERIOD FOR REPLY IS SET TO EXPIRE 3 MONTH(S) OR THIRTY (30) DAYS, WHICHEVER IS LONGER, FROM THE MAILING DATE OF THIS COMMUNICATION.

- Extensions of time may be available under the provisions of 37 CFR 1.136(a). In no event, however, may a reply be timely filed after SIX (6) MONTHS from the mailing date of this communication.
- If NO period for reply is specified above, the maximum statutory period will apply and will expire SIX (6) MONTHS from the mailing date of this communication.
- Failure to reply within the set or extended period for reply will, by statute, cause the application to become ABANDONED (35 U.S.C. § 133). Any reply received by the Office later than three months after the mailing date of this communication, even if timely filed, may reduce any earned patent term adjustment. See 37 CFR 1.704(b).

Status

- 1) Responsive to communication(s) filed on ____.
- 2a) This action is **FINAL**. 2b) This action is non-final.
- 3) Since this application is in condition for allowance except for formal matters, prosecution as to the merits is closed in accordance with the practice under *Ex parte Quayle*, 1935 C.D. 11, 453 O.G. 213.

Disposition of Claims

- 4) Claim(s) 1-53 is/are pending in the application.
4a) Of the above claim(s) ____ is/are withdrawn from consideration.
- 5) Claim(s) ____ is/are allowed.
- 6) Claim(s) 1-53 is/are rejected.
- 7) Claim(s) ____ is/are objected to.
- 8) Claim(s) ____ are subject to restriction and/or election requirement.

Application Papers

- 9) The specification is objected to by the Examiner.
- 10) The drawing(s) filed on ____ is/are: a) accepted or b) objected to by the Examiner.
Applicant may not request that any objection to the drawing(s) be held in abeyance. See 37 CFR 1.85(a).
Replacement drawing sheet(s) including the correction is required if the drawing(s) is objected to. See 37 CFR 1.121(d).
- 11) The oath or declaration is objected to by the Examiner. Note the attached Office Action or form PTO-152.

Priority under 35 U.S.C. § 119

- 12) Acknowledgment is made of a claim for foreign priority under 35 U.S.C. § 119(a)-(d) or (f).
a) All b) Some * c) None of:
1. Certified copies of the priority documents have been received.
2. Certified copies of the priority documents have been received in Application No. ____.
3. Copies of the certified copies of the priority documents have been received in this National Stage application from the International Bureau (PCT Rule 17.2(a)).
- * See the attached detailed Office action for a list of the certified copies not received.

Attachment(s)

- | | |
|------------------------------------------------------------------------------------------------------------------------------------------|-----------------------------------------------------------------------------------------|
| 1) <input type="checkbox"/> Notice of References Cited (PTO-892) | 4) <input type="checkbox"/> Interview Summary (PTO-413)
Paper No(s)/Mail Date. ____. |
| 2) <input type="checkbox"/> Notice of Draftsperson's Patent Drawing Review (PTO-948) | 5) <input type="checkbox"/> Notice of Informal Patent Application |
| 3) <input checked="" type="checkbox"/> Information Disclosure Statement(s) (PTO/SB/08)
Paper No(s)/Mail Date <u>Multiple Sheets</u> . | 6) <input type="checkbox"/> Other: ____. |

DETAILED ACTION

Interview with agreement reached

1. An Agreement was reached during the interview conducted with John L. Adair on August 30, 2010 (See the interview Record). The examiner thanks the applicant for very helpful discussions & cooperation to make the case in condition for allowance. As can be seen from the plurality of related cases, the allowable subject matter over the prior art of record was identified and reached. In order to move the case in condition for allowance & to be consistent with the all of the related/parent cases/specification, the applicant agreed to amend the claims to clearly recite that the claimed mediums (i.e., the first and second mediums) are not the same mediums, but the protocols used on such mediums can be the same or different protocol types. Therefore, the native low level block protocols are used between different mediums that may use the same or different protocol types is consistent with the related cases and specification. In other words, one of the medium is remote, separate & different from the other medium. The applicant also agreed to amend & update the RELATED APPLICATIONS of the specification; & the applicant agreed to file Terminal Disclaimer against all of the Related Applications. For the above reasons, the examiner implicitly gives rejection as follows.

Double Patenting/Allowable Subject Matter

2. After careful consideration of the present claims and in relation to all of the parent and/or related application, the examiner finds the claimed invention allowable over the

prior art of records (i.e., prior art of records of the parent & related cases). However, the present claimed invention does not overcome the Double patenting rejections against the parent and related patent/applications. The following interview was conducted with the applicant and the agreement was reached.

Interview/Double Patenting Rejection

3. On August 30, 2010, a telephonic interview was conducted and the applicant agreed to file additional Terminal Disclaimer against all of the remaining related pending applications and allowed applications. During the interview, the examiner kindly asks the applicant to make sure that the present and pending applications to be consistent with the related reexamination applications.

4. The nonstatutory double patenting rejection is based on a judicially created doctrine grounded in public policy (a policy reflected in the statute) so as to prevent the unjustified or improper timewise extension of the "right to exclude" granted by a patent and to prevent possible harassment by multiple assignees. See *In re Goodman*, 11 F.3d 1046, 29 USPQ2d 2010 (Fed. Cir. 1993); *In re Longi*, 759 F.2d 887, 225 USPQ 645 (Fed. Cir. 1985); *In re Van Ornum*, 686 F.2d 937, 214 USPQ 761 (CCPA 1982); *In re Vogel*, 422 F.2d 438, 164 USPQ 619 (CCPA 1970); and, *In re Thorington*, 418 F.2d 528, 163 USPQ 644 (CCPA 1969).

A timely filed terminal disclaimer in compliance with 37 CFR 1.321(c) may be used to overcome an actual or provisional rejection based on a nonstatutory double patenting ground provided the conflicting application or patent is shown to be commonly owned with this application. See 37 CFR 1.130(b).

Effective January 1, 1994, a registered attorney or agent of record may sign a terminal disclaimer. A terminal disclaimer signed by the assignee must fully comply with 37 CFR 3.73(b).

a. Since the applicant agreed with the examiner regarding the Double Patenting rejection, the details of the rejection will be omitted.

b. The examiner kindly asks the applicant for help on identifying all of the related applications, if the examiner inadvertently makes a mistake.

5. Claims 1-53 are rejected under the judicially created doctrine of obviousness-type double patenting as being unpatentable over claims of all of the related Patent/Applications as follows. Although the conflicting claims are not identical, they are not patentably distinct from each other because the related applications claim subject matter that are substantially identical to the present claimed invention. The following are the list of the related cases:

6. Claims 1-53 are rejected on the ground of nonstatutory double patenting over claims of U. S. Patent/Applications of all the related cases, since the claims, if allowed, would improperly extend the "right to exclude" already granted in the patent.

The subject matter claimed in the instant application is fully disclosed in the patent and is covered by the patent since the patent and the application are claiming common subject matter.

Furthermore, there is no apparent reason why applicant was prevented from presenting claims corresponding to those of the instant application during prosecution of the application which matured into a patent. See *In re Schneller*, 397 F.2d 350, 158 USPQ 210 (CCPA 1968). See also MPEP § 804.

7. Examiner kindly asks applicant's help for identifying all the related cases (i.e., all the parent and child cases) and submitting T.D. to make the case in condition for

allowance. Further more, the applicant should also submit IDS with all the related prior art of record.

Specification

8. The disclosure is objected to because of the following informalities:

As agreed by the applicant, the RELATED APPLICATIONS sections should be updated.

Appropriate correction is required.

9. Any inquiry concerning this communication or earlier communications from the examiner should be directed to Christopher B. Shin whose telephone number is 571-272-4159. The examiner can normally be reached on Monday Through Friday 6:30AM to 3:00PM.

If attempts to reach the examiner by telephone are unsuccessful, the examiner's supervisor, Kindred Alford can be reached on 571-272-4037. The fax phone number for the organization where this application or proceeding is assigned is 571-273-8300.

Information regarding the status of an application may be obtained from the Patent Application Information Retrieval (PAIR) system. Status information for published applications may be obtained from either Private PAIR or Public PAIR. Status information for unpublished applications is available through Private PAIR only. For more information about the PAIR system, see <http://pair-direct.uspto.gov>. Should you have questions on access to the Private PAIR system, contact the Electronic Business Center (EBC) at 866-217-9197 (toll-free). If you would like assistance from a USPTO Customer Service Representative or access to the automated information system, call 800-786-9199 (IN USA OR CANADA) or 571-272-1000.

/Christopher B Shin/
Primary Examiner, Art Unit 2181

CS

Search Notes



Application/Control No.

12/690,592

Applicant(s)/Patent under Reexamination

HOESE ET AL.

Examiner

Christopher B. Shin

Art Unit

2181

SEARCHED

Class	Subclass	Date	Examiner
710	1-5,8-13,36-38,126-131	8/30/2010	CS
710	250, 305-	8/30/2010	CS
709	258	8/30/2010	CS
714	42	8/30/2010	CS
711	110-113	8/30/2010	CS

INTERFERENCE SEARCHED

Class	Subclass	Date	Examiner
710	305,11		
709	258		

**SEARCH NOTES
(INCLUDING SEARCH STRATEGY)**

	DATE	EXMR
PLUS from the parent cases	8/30/2010	CS
PALM- for double patenting	8/30/2010	CS
EAST (See notes for parent)	8/30/2010	CS
PARETN & RELATED CASES REVIEWED FOR THE ALLOWANCE	8/30/2010	CS
Reviewed IDS	8/30/2010	CS



**INFORMATION DISCLOSURE
STATEMENT BY APPLICANT**

Application Number	12/690,592
Filing Date	01/20/2010
First Named Inventor	Geoffrey B. Hoes
Group Art Unit	2111
Examiner Name	Unknown
Attorney Docket Number	CROSS1120-33

Sheet **1** of **9**

U.S. PATENT DOCUMENTS

Examiner Initials	Cite No.	Document Number	Publication Date MM-DD-YYYY	Name of Patentee or Applicant of Cited Document	Pages, Columns, Lines Where Relevant Passages or Figures Appear
		Number-Kind Code (if known)			
	A1	3,082,406	3/19/1963	L.D. Stevens	
	A2	4,092,732	5/30/1978	Ouchi	
	A3	4,170,415	10/9/1979	Lemeshewsky, et al.	
	A4	4,415,970	11/15/1983	Swenson, et al.	
	A5	4,455,605	6/19/1984	Cormier, et al.	
	A6	4,504,927	3/12/1985	Callan	
	A7	4,533,996	8/6/1985	Gartung, et al.	
	A8	4,573,152	2/25/1986	Greene, et al.	
	A9	4,603,380	7/29/1986	Easton, et al.	
	A10	4,620,295	10/28/1986	Aiden, Jr.	
	A11	4,644,462	2/17/1987	Matsubara, et al.	
	A12	4,695,948	9/22/1987	Blevins, et al.	
	A13	4,697,232	9/29/1987	Brunelle, et al.	
	A14	4,715,030	12/22/1987	Koch, et al.	
	A15	4,751,635	6/14/1988	Kret	
	A16	4,787,028	11/22/1988	Finforck, et al.	
	A17	4,807,180	2/21/1989	Takeuchi, et al.	
	A18	4,811,278	3/7/1989	Bean, et al.	
	A19	4,821,179	4/11/1989	Jensen, et al.	
	A20	4,825,406	4/25/1989	Bean, et al.	
	A21	4,827,411	5/2/1989	Arrowood, et al.	
	A22	4,835,674	5/30/1989	Collins, et al.	
	A23	4,845,722	7/4/1989	Kent et al.	
	A24	4,864,532	9/5/1989	Reeve, et al.	
	A25	4,897,874	1/30/1990	Lidensky, et al.	
	A26	4,947,367	8/7/1990	Chang, et al.	
	A27	4,961,224	10/2/1990	Yung	
	A28	5,072,378	12/10/1991	Manka	
	A29	5,077,732	12/31/1991	Fischer, et al.	
	A30	5,077,736	12/31/1991	Dunphy, Jr., et al.	
	A31	5,124,987	6/23/1992	Milligan, et al.	
	A32	5,155,845	10/13/1992	Beal, et al.	
	A33	5,163,131	11/10/1992	Row, et al.	
	A34	5,185,876	2/9/1993	Nguyen, et al.	
	A35	5,193,168	3/9/1993	Corrigan, et al.	
	A36	5,193,184	3/9/1993	Belsan, et al.	
	A37	5,202,856	4/13/1993	Glider, et al.	
	A38	5,210,866	5/11/1993	Milligan, et al.	
Examiner Signature	/Christopher Shin/			Date Considered	08/26/2010

ALL REFERENCES CONSIDERED EXCEPT WHERE LINED THROUGH. /C.S./

INFORMATION DISCLOSURE STATEMENT BY APPLICANT				Application Number	12/690,592	
				Filing Date	01/20/2010	
				First Named Inventor	Geoffrey B. Hoese	
				Group Art Unit	2111	
				Examiner Name	Unknown	
Sheet	2	of	9	Attorney Docket Number	CROSS1120-33	
U.S. PATENT DOCUMENTS						
Examiner Initials	Cite No.	Document Number		Publication Date MM-DD-YYYY	Name of Patentee or Applicant of Cited Document	Pages, Columns, Lines Where Relevant Passages or Figures Appear
		Number-Kind Code (if known)				
	A39	5,212,785		5/18/1993	Powers, et al.	
	A40	5,214,778		5/25/1993	Glider, et al.	
	A41	5,226,143		7/6/1993	Baird, et al.	
	A42	5,239,632		8/24/1993	Larner	
	A43	5,239,643		8/24/1993	Blount, et al.	
	A44	5,239,654		8/24/1993	Ing-Simmons, et al.	
	A45	5,247,638		9/21/1993	O'Brien, et al.	
	A46	5,247,692		9/21/1993	Fujimura	
	A47	5,257,386		10/26/1993	Saito	
	A48	5,297,262		3/22/1994	Cox, et al.	
	A49	5,301,290		4/5/1994	Tetzlaff, et al.	
	A50	5,315,657		5/24/1994	Abadi, et al.	
	A51	5,317,693		5/31/1994	Elko, et al.	
	A52	5,331,673		7/19/1994	Elko, et al.	
	A53	5,347,384		9/13/1994	McReynolds, et al.	
	A54	5,355,453		10/11/1994	Glider, et al.	
	A55	5,361,347		11/1/1994	Glider, et al.	
	A56	5,367,646		11/22/1994	Pardillos, et al.	
	A57	5,379,385		1/3/1995	Shomler	
	A58	5,379,398		1/3/1995	Cohn, et al.	
	A59	5,388,243		2/7/1995	Glider, et al.	
	A60	5,388,246		2/7/1995	Kasi	
	A61	5,394,402		2/28/1995	Ross, et al.	
	A62	5,394,526		2/28/1995	Crouse et al.	
	A63	5,396,596		3/7/1995	Hashemi, et al.	
	A64	5,403,639		4/4/1995	Belsan, et al.	
	A65	5,410,667		4/25/1995	Belsan, et al.	
	A66	5,410,697		4/25/1995	Baird, et al.	
	A67	5,414,820		10/9/1995	McFarland, et al.	
	A68	5,416,915		5/16/1995	Mattson, et al.	
Examiner Signature		/Christopher Shin/			Date Considered	08/26/2010

ALL REFERENCES CONSIDERED EXCEPT WHERE LINED THROUGH. /C.S./

INFORMATION DISCLOSURE STATEMENT BY APPLICANT				Application Number	12/690,592	
				Filing Date	01/20/2010	
				First Named Inventor	Geoffrey B. Hoese	
				Group Art Unit	2111	
				Examiner Name	Unknown	
Sheet	3	of	9	Attorney Docket Number	CROSS1120-33	
U.S. PATENT DOCUMENTS						
Examiner Initials	Cite No.	Document Number		Publication Date MM-DD-YYYY	Name of Patentee or Applicant of Cited Document	Pages, Columns, Lines Where Relevant Passages or Figures Appear
		Number-Kind Code (if known)				
	A69	5,418,909		5/23/1995	Jachowski, et al.	
	A70	5,420,988		5/30/1995	Elliott	
	A71	5,423,026		6/6/1995	Cook, et al.	
	A72	5,423,044		6/6/1995	Sutton, et al.	
	A73	5,426,637		6/20/1995	Derby, et al.	
	A74	5,430,855		7/4/1995	Wash, et al.	
	A75	5,450,570		9/12/1995	Richek, et al.	
	A76	5,452,421		9/19/1995	Beardsley, et al.	
	A77	5,459,857		10/17/1995	Ludlam, et al.	
	A78	5,463,754		10/31/1995	Beausoleil, et al.	
	A79	5,465,382		11/7/1995	Day, III, et al.	
	A80	5,469,576		11/21/1995	Dauerer, et al.	
	A81	5,471,609		11/28/1995	Yudenfriend, et al.	
	A82	5,487,077		1/23/1996	Hassner, et al.	
	A83	5,491,812		2/13/1996	Pisello, et al.	
	A84	5,495,474		2/27/1996	Olnowich, et al.	
	A85	5,496,576		3/5/1996	Jeong	
	A86	5,504,857		4/2/1996	Baird, et al.	
	A87	5,507,032		4/9/1996	Kimura	
	A88	5,511,169		4/23/1996	Suda	
	A89	5,519,695		5/21/1996	Purohit, et al.	
	A90	5,530,845		6/25/1996	Hiatt, et al.	
	A91	5,535,352		7/9/1996	Bridges, et al.	
	A92	5,537,585		7/16/1996	Blickerstaff, et al.	
	A93	5,544,313		8/6/1996	Shachnai, et al.	
	A94	5,548,791		8/20/1996	Casper, et al.	
	A95	5,564,019		10/8/1996	Beausoleil, et al.	
	A96	5,568,648		10/22/1996	Coscarella, et al.	
	A97	5,581,709		12/3/1996	Ito, et al.	
	A98	5,581,714		12/3/1996	Amini, et al.	
Examiner Signature	/Christopher Shin/				Date Considered	08/26/2010

ALL REFERENCES CONSIDERED EXCEPT WHERE LINED THROUGH. /C.S./

INFORMATION DISCLOSURE STATEMENT BY APPLICANT				Application Number	12/690,592	
				Filing Date	01/20/2010	
				First Named Inventor	Geoffrey B. Hoese	
				Group Art Unit	2111	
				Examiner Name	Unknown	
Sheet	4	of	9	Attorney Docket Number	CROSS1120-33	
U.S. PATENT DOCUMENTS						
Examiner Initials	Cite No.	Document Number		Publication Date MM-DD-YYYY	Name of Patentee or Applicant of Cited Document	Pages, Columns, Lines Where Relevant Passages or Figures Appear
		Number-Kind Code (if known)				
	A99	5,581,724		12/3/1996	Belsan et al.	
	A100	5,596,562		6/21/1997	Chen	
	A101	5,596,736		1/21/1997	Kerns	
	A102	5,598,541		1/28/1997	Malladi	
	A103	5,613,082		3/18/1997	Brewer, et al.	
	A104	5,621,902		4/15/1997	Cases, et al.	
	A105	5,632,012		5/20/1997	Belsan, et al.	
	A106	5,634,111		5/27/1997	Oeda, et al.	
	A107	5,638,518		6/10/1997	Malladi	
	A108	5,642,515		6/24/1997	Jones, et al.	
	A109	5,659,756		8/19/1997	Hefferon, et al.	
	A110	5,664,107		9/2/1997	Chatwanni, et al.	
	A111	5,680,556		10/21/1997	Begun, et al.	
	A112	5,684,800		11/4/1997	Dobbins, et al.	
	A113	5,701,491		12/23/1997	Dunn, et al.	
	A114	5,712,976		1/27/1998	Falcon, et al.	
	A115	5,727,218		3/10/1998	Hotchkin	
	A116	5,729,705		3/17/1998	Weber	
	A117	5,743,847		4/28/1998	Nakamura, et al.	
	A118	5,748,924		5/5/1998	Llorens, et al.	
	A119	5,571,971		5/12/1998	Dobbins, et al.	
	A120	5,751,975		5/12/1998	Gillespie, et al.	
	A121	5,764,931		6/9/1998	Schmahl, et al.	
	A122	5,768,623		6/16/1998	Judd, et al.	
	A123	5,774,683		6/30/1998	Gulick	
	A124	5,778,411		7/7/1998	DeMoss	
	A125	5,781,715		7/14/1998	Sheu	
	A126	5,802,278		9/1/1998	Isfeld, et al.	
	A127	5,805,816		9/8/1998	Picazo, Jr., et al.	
	A128	5,805,920		9/8/1998	Sprenkle, et al.	
Examiner Signature	/Christopher Shin/				Date Considered	08/26/2010

ALL REFERENCES CONSIDERED EXCEPT WHERE LINED THROUGH. /C.S./

INFORMATION DISCLOSURE STATEMENT BY APPLICANT				Application Number	12/690,592	
				Filing Date	01/20/2010	
				First Named Inventor	Geoffrey B. Hoese	
				Group Art Unit	2111	
				Examiner Name	Unknown	
Sheet	5	of	9	Attorney Docket Number	CROSS1120-33	
U.S. PATENT DOCUMENTS						
Examiner Initials	Cite No.	Document Number		Publication Date MM-DD-YYYY	Name of Patentee or Applicant of Cited Document	Pages, Columns, Lines Where Relevant Passages or Figures Appear
		Number-Kind Code (if known)				
	A129	5,809,328		9/15/1998	Nogales, et al.	
	A130	5,812,754		9/22/1998	Lui, et al.	
	A131	5,819,054		10/6/1998	Ninomiya, et al.	
	A132	5,825,772		10/20/1998	Dobbins, et al.	
	A133	5,835,496		11/10/1998	Yeung, et al.	
	A134	5,845,107		12/1/1998	Fisch, et al.	
	A135	5,848,251		12/8/1998	Lomelino, et al.	
	A136	5,857,080		10/5/1999	Jander, et al.	
	A137	5,860,137		1/12/1999	Raz, et al.	
	A138	5,864,653		1/26/1999	Tavallaeei, et al.	
	A139	5,867,648		2/2/1999	Foth, et al.	
	A140	5,884,027		3/16/1999	Garbus, et al.	
	A141	5,889,952		3/30/1999	Hunnicutt, et al.	
	A142	5,913,045		6/15/1999	Gillespie, et al.	
	A143	5,923,557		7/13/1999	Eidson	
	A144	5,933,824		8/3/1999	DeKoning, et al.	
	A145	5,935,205		8/10/1999	Murayama, et al.	
	A146	5,935,260		8/10/1999	Ofer	
	A147	5,941,969		8/24/1999	Ram, et al.	
	A148	5,941,972		8/24/1999	Hoese, et al.	
	A149	5,946,308		8/31/1999	Dobbins, et al.	
	A150	5,953,511		9/14/1999	Sescilia, et al.	
	A151	5,959,994		9/28/1999	Boggs, et al.	
	A152	5,963,556		10/5/1999	Varghese, et al.	
	A153	5,974,530		10/26/1999	Young	
	A154	5,978,379		11/2/1999	Chan, et al.	
	A155	5,978,875		11/2/1999	Asano, et al.	
	A156	5,991,797		11/23/1999	Futral, et al.	
	A157	6,000,020		12/7/1999	Chin, et al.	
	A158	6,041,058		3/21/2000	Flanders, et al.	
Examiner Signature	/Christopher Shin/				Date Considered	08/26/2010

ALL REFERENCES CONSIDERED EXCEPT WHERE LINED THROUGH. /C.S./

INFORMATION DISCLOSURE STATEMENT BY APPLICANT				Application Number	12/690,592	
				Filing Date	01/20/2010	
				First Named Inventor	Geoffrey B. Hoese	
				Group Art Unit	2111	
				Examiner Name	Unknown	
Sheet	6	of	9	Attorney Docket Number	CROSS1120-33	
U.S. PATENT DOCUMENTS						
Examiner Initials	Cite No.	Document Number		Publication Date MM-DD-YYYY	Name of Patentee or Applicant of Cited Document	Pages, Columns, Lines Where Relevant Passages or Figures Appear
		Number-Kind Code (if known)				
	A159	6,021,451		2/1/2000	Bell, et al.	
	A160	6,029,168		2/22/2000	Frey	
	A161	6,032,269		2/29/2000	Renner, Jr.	
	A162	6,041,381		3/21/2000	Hoese	
	A163	6,055,603		4/25/2000	Ofer, et al.	
	A164	6,065,087		5/16/2000	Keaveny, et al.	
	A165	6,070,253		5/30/2000	Tavallaei, et al.	
	A166	6,073,209		6/6/2000	Bergsten	
	A167	6,073,218		6/6/2000	DeKoning, et al.	
	A168	6,075,863		6/13/2000	Krishnan, et al.	
	A169	6,081,849		6/27/2000	Born, et al.	
	A170	6,098,128		8/1/2000	Velez-McCaskey et al.	
	A171	6,098,149		8/1/2000	Ofer, et al.	
	A172	6,108,684		8/22/2000	DeKoning, et al.	
	A173	6,118,766		9/12/2000	Akers	
	A174	6,131,119		10/10/2000	Fukui	
	A175	6,134,617		10/17/2000	Weber	
	A176	6,141,737		10/31/2000	Krantz, et al.	
	A177	6,145,006		11/7/2000	Vishlitsky, et al.	
	A178	6,147,976		11/14/2000	Shand, et al.	
	A179	6,147,995		11/14/2000	Dobbins, et al.	
	A180	6,148,004		11/14/2000	Nelson, et al.	
	A181	6,173,399		1/9/2001	Gilbrech	
	A182	6,185,203		2/6/2001	Berman	
	A183	6,202,153		3/13/2001	Diamant, et al.	
	A184	6,209,023		3/27/2001	Dimitroff, et al.	
	A185	6,219,771		4/17/2001	Kikuchi, et al.	
	A186	6,223,266		4/24/2001	Sartore	
	A187	6,230,218		5/8/2001	Casper, et al.	
	A188	6,243,827		6/5/2001	Renner, Jr.	
				Date Considered	08/26/2010	
				/Christopher Shin/		

ALL REFERENCES CONSIDERED EXCEPT WHERE LINED THROUGH. /C.S./

INFORMATION DISCLOSURE STATEMENT BY APPLICANT				Application Number	12/690,592	
				Filing Date	01/20/2010	
				First Named Inventor	Geoffrey B. Hoese	
				Group Art Unit	2111	
				Examiner Name	Unknown	
Sheet	7	of	9	Attorney Docket Number	CROSS1120-33	
U.S. PATENT DOCUMENTS						
Examiner Initials	Cite No.	Document Number		Publication Date MM-DD-YYYY	Name of Patentee or Applicant of Cited Document	Pages, Columns, Lines Where Relevant Passages or Figures Appear
		Number-Kind Code (if known)				
	A189	6,260,120		7/10/2001	Blumenau, et al.	
	A190	6,268,789		7/31/2001	Diamant, et al.	
	A191	6,308,247		10/23/2001	Ackerman	
	A192	6,330,629		12/11/2001	Kondo, et al.	
	A193	6,330,687		12/11/2001	Griffith	
	A194	6,341,315		1/22/2002	Arroyo, et al.	
	A195	6,343,324		1/29/2002	Hubis, et al.	
	A196	6,363,462		3/26/2002	Bergsten	
	A197	6,401,170		6/4/2002	Griffith, et al.	
	A198	6,421,753		7/16/2002	Hoese, et al.	
	A199	6,425,035		7/23/2002	Hoese, et al.	
	A200	6,425,036		7/23/2002	Hoese, et al.	
	A201	6,425,052		6/23/2002	Hashemi	
	A202	6,453,345		9/17/2002	Trcka, et al.	
	A203	6,484,245		11/19/2002	Sanada, et al.	
	A204	6,529,996		3/4/2003	Nguyen, et al.	
	A205	6,547,576		4/15/2003	Peng, et al.	
	A206	6,560,750		5/6/2003	Chien, et al.	
	A207	6,563,701		5/13/2003	Peng, et al.	
	A208	6,775,693		8/10/2004	Adams	
	A209	6,792,602		9/14/2004	Lin, et al.	
	A210	6,820,212		11/16/2004	Duchesne, et al.	
	A211	6,854,027		2/8/2005	Hsu, et al.	
	A212	6,862,637		3/1/2005	Stupar	
	A213	6,874,043		3/29/2005	Treggiden	
	A214	6,874,100		3/29/2005	Rauscher	
	A215	6,910,083		6/21/2005	Hsu, et al.	
	A216	7,065,076		6/20/2006	Nemazie	
	A217	7,127,668		10/24/2006	McBryde, et al.	
	A218	7,133,965		11/7/2006	Chien	
Examiner Signature	/Christopher Shin/				Date Considered	08/26/2010

ALL REFERENCES CONSIDERED EXCEPT WHERE LINED THROUGH. /C.S./

INFORMATION DISCLOSURE STATEMENT BY APPLICANT				Application Number	12/690,592	
				Filing Date	01/20/2010	
				First Named Inventor	Geoffrey B. Hoese	
				Group Art Unit	2111	
				Examiner Name	Unknown	
Sheet	8	of	8	Attorney Docket Number	CROSS1120-33	
U.S. PATENT DOCUMENTS						
Examiner Initials	Cite No.	Document Number		Publication Date MM-DD-YYYY	Name of Patentee or Applicant of Cited Document	Pages, Columns, Lines Where Relevant Passages or Figures Appear
		Number-Kind Code (if known)				
	A219	7,188,111		3/6/2007	Chen, et al.	
	A220	7,216,225		5/8/2007	Haviv, et al.	
	A221	7,251,248		7/31/2007	Trossell, et al.	
	A222	7,281,072		10/9/2007	Liu, et al.	
	A223	D470,486		2/18/2003	Cheng	
	A224	2002/0083221		6/27/2002	Tsai, et al.	
	A225	2006/0277326		12/7/2006	Tsai, et al.	
	A226	2006/0294416		12/28/2006	Tsai, et al.	
	A227	2006/0218322		09/2006	Hoese, et al.	
FOREIGN PATENT DOCUMENTS						
Examiner Initials	Cite No.	Foreign Patent Document		Publication Date MM-DD-YYYY (Number 43)	Name of Patentee or Applicant of Cited Document	Pages, Columns, Lines Where Relevant Passages or Figures Appear
		Country Code-Number-Kind Code (if known)				
	B1	GB 2296798 A		7/10/1996	Spring Consultants Limited	
	B2	GB 2297636 A		8/7/1996	Spring Consultants Limited	
	B3	JP 8-230895		9/10/1996	Kikuchi, et al.	
	B4	EP 0810530 A2		12/3/1997	Sun Microsystems, Inc.	
	B5	EP 0827059 A2		3/4/1998	NEC Corporation	
	B6	WO 99/34297 A1		7/8/1999	Crossroads Systems, Inc.	
Examiner Signature	/Christopher Shin/				Date Considered	08/26/2010

ALL REFERENCES CONSIDERED EXCEPT WHERE LINED THROUGH. /C.S./

INFORMATION DISCLOSURE STATEMENT BY APPLICANT				Application Number	12/690,592
				Filing Date	01/20/2010
				First Named Inventor	Geoffrey B. Hoesel
				Group Art Unit	2111
				Examiner Name	Unknown
Sheet	9	of	9	Attorney Docket Number	CROSS1120-33
U.S. PATENT DOCUMENTS					
Examiner Initials	Cite No.	Document Number Number-Kind Code (if known)	Publication Date MM-DD-YYYY	Name of Patentee or Applicant of Cited Document	Pages, Columns, Lines Where Relevant Passages or Figures Appear
FOREIGN PATENT DOCUMENTS					
Examiner Initials	Cite No.	Foreign Patent Document Country Code-Number-Kind Code (if known)	Publication Date MM-DD-YYYY (Number 43)	Name of Patentee or Applicant of Cited Document	Pages, Columns, Lines Where Relevant Passages or Figures Appear
	B7	GB 2341715	03/22/2000	SpringTek Limited	
	B8	JP 6301607	10/28/1994	Hitachi Ltd.	
	B9	WO 98/36357	08/20/1998	Transwitch Corporation	
	B10	WO 91/03788	3/21/1991	Auspex Systems, Inc.	
	B11	WO 1997033227	8/4/1998	Nippon Telegraph & AMP; Telephone Corp.	
	B12	AU 647414	3/24/1994	Auspex Systems, Inc.	
	B13	AU 670376	7/11/1996	Auspex Systems, Inc.	
	B14	CA 2066443	10/21/2003	Auspex Systems, Inc.	
	B15	EP 0490973	2/25/1998	Auspex Systems, Inc.	
	B16	IL 095447	5/30/1994	Auspex Systems, Inc.	
	B17	IL 107645	9/12/1996	Auspex Systems, Inc.	
	B18	JP 10097493	4/14/1998	Sun Microsyst. Inc.	
	B19	JP 1997251437	9/22/1997	Toshiba Corporation	
	B20	JP 1993181609	7/23/1993	NEC Corp.	
	B21	JP 1997185594	7/15/1997	Tandem Computers, Inc.	
	B22	JP 1995020994	1/24/1995	Hitachi, Ltd.	
	B23	JP 5502525	4/28/1993	Auspex Systems, Inc.	
	B24	JP 5181609	7/23/1993	Nippon Electric Co.	
	B25	JP 720994	1/24/1995	Hitachi Seisakusho Co., Ltd.	
Examiner Signature	/Christopher Shin/			Date Considered	08/26/2010

ALL REFERENCES CONSIDERED EXCEPT WHERE LINED THROUGH. /C.S./

INFORMATION DISCLOSURE STATEMENT				Application Number	12/690,592	
				Filing Date	01/20/2010	
				First Named Inventor	Geoffrey B. Hoesse	
				Group Art Unit	2111	
				Examiner Name	Unknown	
Sheet	1	of	9	Atty Docket Number	CROSS1120-33	
Examiner Initials	Cite No.	OTHER PRIOR ART -- NON PATENT LITERATURE DOCUMENTS			Date	
	C4	Black Box, SCSI Fiberoptic Extender, Single-Ended, Product Insert, 2 pages, 1996			6/18/1905	
	C5	Block-Based Distributed File Systems, Anthony J. McGregor, July 1997				
	C6	Compaq StorageWorks HSG80 Array Controller ACS Version 8.3 (Maintenance and Service Guide) 11/98				
	C7	Compaq StorageWorks HSG80 Array Controller ACS Version 8.3 (Configuration and CLI Reference Guide) 11/98				
	C8	CRD-5500, RAID DISK ARRAY CONTROLLER Product Insert, pp. 1-5				
	C9	CRD-5500, SCSI RAID CONTROLLER OEM Manual, Rev. 1.3, February 26, 1996, pp. 1-54			2/26/1996	
	C10	CRD-5500, SCSI RAID CONTROLLER Users Manual, Rev. 1.3, November 21, 1996, pp. 10-92			11/21/1996	
	C11	DIGITAL StorageWorks HSZ70 Array Controller HSOF Version 7.0 EK-SHZ70-RM.A01 CLI Reference Manual.			7/1/1997	
	C12	DIGITAL Storage Works, HSZ70 Array Controller, HSOF Version 7.0 EK-HSZ70-CG. A01, Digital Equipment Corporation, Maynard, Massachusetts			7/1/1997	
	C13	DIGITAL StorageWorks, Using Your HSZ70 Array Controller in a SCSI Controller Shelf (DS-BA356-M Series), User's Guide, pp. 1-1 through A-5 with index, January 1998.			1/1/1998	
	C14	DIGITAL StorageWorks HSZ70 Array Controller HSOF Version 7.0 EK-HSZ70-SV. A01			1997-	
	C15	DIGITAL StorageWorks HSG80 Array Controller ACS Version 8.0 (User's Guide 1/98				
	C16	DP5380 Asynchronous SCSI Interface, National Semiconductor Corporation, Arlington, TX, May 1989, pp. 1-32				
	C17	Emerson, "Encor Communications: Performance evaluation of switched fibre channel I/O system using--FCP for SCSI" February 1995, IEEE, pp. 479-484			2/1/1995	
	C18	Fiber channel (FCS)/ATM internetworking: a design solution				
	C19	Fiber Channel storage interface for video-on-demand servers by Anazaloni, et al.			6/15/1905	
	C20	Fibre Channel and ATM: The Physical Layers, Jerry Quam WESCON/94, published 27-29 September 1994. Pages 648-652.				
	C21	Gen5 S-Series XL System Guide Revision 1.01 by Chen			6/18/1905	
	C22	Graphical User Interface for MAXSTRAT Gen5/Gen-S Servers User's guide 1.1			6/11/1996	
	C23	High Performance Data transfers Using Network-Attached Peripherals at the national Storage Laboratory by Hyer			2/26/1993	
Examiner Signature		/Christopher Shin/			Date Considered	08/26/2010

ALL REFERENCES CONSIDERED EXCEPT WHERE LINED THROUGH. /C.S./

INFORMATION DISCLOSURE STATEMENT				Application Number	12/690,592	
				Filing Date	01/20/2010	
				First Named Inventor	Geoffrey B. Hoese	
				Group Art Unit	2111	
				Examiner Name	Unknown	
Sheet	2	of	9	Atty Docket Number	CROSS1120-33	
Examiner Initials	Cite No.	OTHER PRIOR ART -- NON PATENT LITERATURE DOCUMENTS			Date	
	C24	IFT-3000 SCSI to SCSI Disk array Controller Instruction Manual Revision 2.0 by Infotrend Technologies, Inc.			1995-	
	C25	Implementing a Fibre Channel SCSI transport by Snively			1994-	
	C26	"InfoServer 150--Installation and Owner's Guide", EK-INFSV-OM-001, Digital Equipment Corporation, Maynard, Massachusetts 1991, Chapters 1 and 2				
	C27	InfoServer 150VXT Photograph				
	C28	IBM Technical Publication: Guide to Sharing and Partitioning IBM Tape Library Dataservers, November 1996, pp. 1-256			11/1/1996	
	C29	IBM Technical Publication: Magstar and IBM 3590 High Performance Tape Subsystem Technical Guide, November 1996, pp. 1-269			11/1/1996	
	C30	Misc. Reference Manual Pages, SunOS 5.09				
	C31	InfoServer 100 System Operations Guide, First Edition Digital Equipment Corporation, 1990				
	C32	Johnson, D.B., et al., "The Peregrine High Performance RPC System", Software-Practice and Experience, 23(2):201-221, Feb. 1993				
	C33	Local-Area networks for the IBM PC by Haugdahl				
	C34	New serial I/Os speed storage subsystems by Bursky			2/6/1995	
	C35	Petal: Distributed Virtual Disks, Edward K. Lee and Chandramohan A. Thekkath, ACM SIGPLAN Notices, Volume 31, Issue 9, September 1996, pages 84-92.				
	C36	Pictures of internal components of the InfoServer 150, taken from http://bindarydinosaurs.couk/Museum/Digital/infoServer/infoServer.php in Nov. 2004.				
	C37	Raidtec FibreArray and Raidtec FlexArray UltraRAID Systems", Windows IT PRO Article, October 1997				
	C38	S.P. Joshi, "Ethernet controller chip interfaces with variety of 16-bit processors," electronic Design, Hayden Publishing Co., Inc., Rochelle Park, NJ, October 14, 1982. pp 193-200				
	C39	Simplest Migration to Fibre Channel Technology" Article, Digital Equipment Corporation, November 10, 1997, published on PR Newswire			11/10/1997	
	C40	Systems Architectures Using Fibre Channel, Roger Cummings, Twelfth IEEE Symposium on Mass Storage Systems, Copyright 1993 IEEE. Pages 251-256				
	C41	Office Action dated 01/21/03 for 10/174,720 (CROSS1120-8)			1/21/2003	
	C42	Office Action dated 02/27/01 for 09/354,682 (CROSS1120-1)			2/27/2001	
	C43	Office Action dated 08/11/00 for 09/354,682 (CROSS1120-1)			8/11/2000	
	C44	Office Action dated 12/16/99 for 09/354,682 (CROSS1120-1)			12/16/1999	
	C45	Office Action dated 11/06/02 for 10/023,786 (CROSS1120-4)			11/6/2002	
	C46	Office Action dated 01/21/03 for 10/081,110 (CROSS1120-5)			1/21/2003	
Examiner Signature		/Christopher Shin/			Date Considered	08/26/2010

ALL REFERENCES CONSIDERED EXCEPT WHERE LINED THROUGH. /C.S./

INFORMATION DISCLOSURE STATEMENT				Application Number	12/690,592
				Filing Date	01/20/2010
				First Named Inventor	Geoffrey B. Hoese
				Group Art Unit	2111
				Examiner Name	Unknown
Sheet	3	of	9	Atty Docket Number	CROSS1120-33

Examiner Initials	Cite No.	OTHER PRIOR ART -- NON PATENT LITERATURE DOCUMENTS	Date
	C47	Office Action in Ex Parte Reexamination 90/007,127, mailed February 7, 2005.	2/7/2005
	C48	Office Action in Ex Parte Reexamination 90/007,125, mailed February 7, 2005.	2/7/2005
	C49	Office Action in Ex Parte Reexamination 90/007,126, mailed February 7, 2005.	2/7/2005
	C50	Office Action in Ex Parte Reexamination 90/007,124, mailed February 7, 2005.	2/7/2005
	C51	Office Action in Ex Parte Reexamination 90/007,123, mailed February 7, 2005.	2/7/2005
	C52	European Office Action issued April 1, 2004 in Application No. 98966104.6-2413	4/1/2004
	C53	Office Action dated 1/27/2005 in 10/658,163 (CROSS1120-13)	1/27/2005
	C54	DIGITAL "System Support Addendum", SSA 40.78.01-A, AE-PNZJB-TE, pgs 1-3	4/1/1993
	C55	DIGITAL "Software Product Description", SSA 40.78.01, AE-PNZJB-TE, pgs 1-3	4/1/1993
	C56	DIGITAL EQUIPMENT CORPORATION, "InfoServer 100 Installation and Owner's Guide", Order Number EK-DIS1K-IN-001, First Edition	10/1/1990
	C57	DIGITAL EQUIPMENT CORPORATION, "InfoServer 100 System Operation Guide", Order Number EK-DIS1K-UG-001, First Edition, pgs i-Index 5	10/1/1990
	C58	ELLIOTT, "Working Draft American National Standard, Project T10/1562-D, Revision 5, pgs. i-432	7/9/2003
	C59	SATRAN, "Standards-Track," May 2001, iSCSI, pgs. 9-87	11/1/2000
	C60	SATRAN, et al. "IPS Internet Draft, iSCSI, pgs 1-8	11/1/2000
	C61	APT TECHNOLOGIES, INC., "Serial ATA: High Speed Serialized AT Attachment", Rev. 1.0a, pgs. 1-310	1/7/2003
	C63	Defendant's First Supplemental Trial Exhibit List, Crossroads Systems, Inc., v. Chaparral Network Storage, Inc., C.A. No. A-00CA-217-SS (W.D. Tex. 2001). (CD-Rom)	
	C64	Defendant's Third Supplemental Trial Exhibit List, Crossroads Systems, Inc. v. Pathlight Technology, Inc., C.A. No. A-00CA-248-SS (W.D. Tex. 2001) (CD-Rom)	
	C65	Plaintiff's Fourth Amended Trail Exhibit List, Crossroads Systems, Inc. v. Chaparral Network Storage, Inc, C.A. No. A-00CA-217-SS (W.D. Tex. 2001) (CD-Rom)	
	C66	Plaintiff's Revised Trial Exhibit List, Crossroads Systems, Inc. v. Pathlight Technology, Inc., C.A. No. A-00CA-248-SS (W.D. Tex. 2001). (CD-Rom)	
	C67	Trail Transcripts, Crossroads Systems, Inc. v. Chaparral Network Storage, Inc., C.A. No. A-00CA-217-SS (W.D. Tex. 2001) Day 1 -5 (CD-Rom)	
	C68	Trail Transcripts, Crossroads Systems, Inc. v. Pathlight Technology, Inc., C.A. No. A-00CA-248-SS (W.D. Tex. 2001). Day 1-4 (CD-Rom)	
Examiner Signature	/Christopher Shin/		Date Considered 08/26/2010

ALL REFERENCES CONSIDERED EXCEPT WHERE LINED THROUGH. /C.S./

INFORMATION DISCLOSURE STATEMENT				Application Number		12/690,592	
				Filing Date		01/20/2010	
				First Named Inventor		Geoffrey B. Hoese	
				Group Art Unit		2111	
				Examiner Name		Unknown	
Sheet	4	of	9	Atty Docket Number		CROSS1120-33	
Examiner Initials	Cite No.	OTHER PRIOR ART -- NON PATENT LITERATURE DOCUMENTS				Date	
	C72	Datasheet for CrossPoint 4100 Fibre Channel to SCSI Router (Dedek Ex 41 (ANCT 117-120)) (CD-ROM Chaparral Exhibits D012)					
	C73	Symbios Logic- Software Interface Specification Series 3 SCSI RAID Controller Software Release 02.xx (Engelbrecht Ex 2 (LSI 1421-1658)) (CD-ROM Chaparral Exhibits D013)				12/3/1997	
	C74	Press Release- Symbios Logic to Demonstrate Strong Support for Fibre Channel at Fall Comdex (Engelbrecht 12 (LSI 2785-86)) (CD-ROM Chaparral Exhibits D016)				11/13/1996	
	C75	OEM Datasheet on the 3701 Controller (Engelbrecht 13 (LSI 01837-38)) (CD-ROM Chaparral Exhibits D017)				6/17/1905	
	C76	Nondisclosure Agreement Between Adaptec and Crossroads Dated 10/17/96 (Quisenberry Ex 25 (CRDS 8196)) (CD-ROM Chaparral Exhibits D020)				10/17/1996	
	C77	Organizational Presentation on the External Storage Group (Lavan Ex 1 (CNS 182242-255)) (CD-ROM Chaparral Exhibits D021)				4/11/1996	
	C78	Bridge Phase II Architecture Presentation (Lavan Ex 2 (CNS 182287-295)) (CD-ROM Chaparral Exhibits D022)				4/12/1996	
	C79	Bridge. C, Bridge Between SCSI-2 and SCSI-3 FCP (Fibre Channel Protocol) (CD-ROM Chaparral Exhibits P214)					
	C80	Attendees/Action Items from 4/12/96 Meeting at BTC (Lavan Ex 3 (CNS 182241)) (CD-ROM Chaparral Exhibits D023)				4/12/1996	
	C81	Brooklyn Hardware Engineering Requirements Documents, Revision 1.4 (Lavan Ex 4 (CNS 178188-211)) (CD-ROM Chaparral Exhibits D024) by Pecone				5/26/1996	
	C82	Brooklyn Single-Ended SCSI RAID Bridge Controller Hardware OEM Manual, Revision 2.1 (Lavan EX 5 (CNS 177169-191)) (CD-ROM Chaparral Exhibits D025)				3/2/1996	
	C83	Coronado Hardware Engineering Requirements Document, Revision 0.0 (Lavan Ex 7 (CNS 176917-932)) (CD-ROM Chaparral Exhibits D027) by O'Dell				9/30/1996	
	C84	ESS/FPG Organization (Lavan Ex 8 (CNS 178639-652)) (CD-ROM Chaparral Exhibits D028)				12/6/1996	
	C85	Adaptec MCS ESS Presents: Intelligent External I/O Raid Controllers "Bridge" Strategy (Lavan Ex 9 (CNS 178606-638)). (CD-ROM Chaparral Exhibits D029)				2/6/1996	
	C86	AEC-7313 Fibre Channel Daughter Board (for Brooklyn) Engineering Specification, Revision 1.0 (Lavan Ex 10 (CNS 176830-850)) (CD-ROM Chaparral Exhibits D030)				2/27/1997	
	C87	Bill of Material (Lavan Ex 14 (CNS 177211-214)) (CD-ROM Chaparral Exhibits D034)				7/24/1997	
	C88	AEC-. 4412B, AEC-7412/B2 External RAID Controller Hardware OEM Manual, Revision 2.0 (Lavan Ex 15 (CNS 177082-123)) (CD-ROM Chaparral Exhibits D035)				6/27/1997	
Examiner Signature		/Christopher Shin/				Date Considered	08/26/2010

ALL REFERENCES CONSIDERED EXCEPT WHERE LINED THROUGH. /C.S./

INFORMATION DISCLOSURE STATEMENT				Application Number	12/690,592	
				Filing Date	01/20/2010	
				First Named Inventor	Geoffrey B. Hoesle	
				Group Art Unit	2111	
				Examiner Name	Unknown	
Sheet	5	of	9	Atty Docket Number	CROSS1120-33	
Examiner Initials	Cite No.	OTHER PRIOR ART -- NON PATENT LITERATURE DOCUMENTS			Date	
	C89	Coronado II, AEC-7312A Fibre Channel Daughter (for Brooklyn) Hardware Specification, Revision 1.2 (Lavan Ex 16 (CNS 177192-210)) (CD-ROM Chaparral Exhibits D036) by Tom Yang			7/18/1997	
	C90	AEC-4412B, AEC7412/3B External RAID Controller Hardware OEM Manual, Revision 3.0. (Lavan Ex 17 (CNS 177124-165)) (CD-ROM Chaparral Exhibits D037)			8/25/1997	
	C91	Memo Dated 8/15/97 to AEC-7312A Evaluation Unit Customers re: B001 Release Notes (Lavan Ex 18 (CNS 182878-879)) (CD-ROM Chaparral Exhibits D038)			8/15/1997	
	C92	Brooklyn Main Board (AES-0302) MES Schedule (Lavan Ex 19 (CNS 177759-763)) (CD-ROM Chaparral Exhibits D039)			2/11/1997	
	C93	News Release-Adaptec Adds Fibre Channel Option to its External RAID Controller Family (Lavan Ex 20 (CNS 182932-934)) (CD-ROM Chaparral Exhibits D040)			5/6/1997	
	C94	AEC-4412B/7412B User's Guide, Rev. A (Lavan Ex 21) (CD-ROM Chaparral Exhibits D041)			6/19/1905	
	C95	Data Book- AIC-7895 PCI Bus Master Single Chip SCSI Host Adapter (Davies Ex 1 (CNS 182944-64)) (CD-ROM Chaparral Exhibits D046)			5/21/1996	
	C96	Data Book- AIC-1160 Fibre Channel Host Adapter ASIC (Davies Ex 2 (CNS 181800-825)) (CD-ROM Chaparral Exhibits D047)			6/18/1905	
	C97	Viking RAID Software (Davies Ex 3 (CNS 180969-181026)) (CD-ROM Chaparral Exhibits D048)			6/18/1905	
	C98	Header File with Structure Definitions (Davies Ex 4 (CNS 180009-018)) (CD-ROM Chaparral Exhibits D049)			8/8/1996	
	C99	C++ SourceCode for the SCSI Command Handler (Davies Ex 5 (CNS 179136-168)) (CD-ROM Chaparral Exhibits D050)			8/8/1996	
	C100	Header File Data Structure (Davies Ex 6 (CNS 179997-180008)) (CD-ROM Chaparral Exhibits D051)			1/2/1997	
	C101	SCSI Command Handler (Davies Ex 7 (CNS 179676-719)) (CD-ROM Chaparral Exhibits D052)			1/2/1997	
	C102	Coronado: Fibre Channel to SCSI Intelligent RAID Controller Product Brief (Kalwitz Ex 1 (CNS 182804-805)) (CD-ROM Chaparral Exhibits D053)				
	C103	Bill of Material (Kalwitz Ex 2 (CNS 181632-633)) (CD-ROM Chaparral Exhibits D054)			3/17/1997	
	C104	Emails Dated 1/13-3/31/97 from P. Collins to Mo re: Status Reports (Kalwitz Ex 3 (CNS 182501-511)) (CD-ROM Chaparral Exhibits D055)				
	C105	Hardware Schematics for the Fibre Channel Daughtercard Coronado (Kalwitz Ex 4 (CNS 181639-648)) (CD-ROM Chaparral Exhibits D056)				
Examiner Signature		/Christopher Shin/			Date Considered	08/26/2010

ALL REFERENCES CONSIDERED EXCEPT WHERE LINED THROUGH. /C.S./

INFORMATION DISCLOSURE STATEMENT				Application Number		12/690,592
				Filing Date		01/20/2010
				First Named Inventor		Geoffrey B. Hoese
				Group Art Unit		2111
				Examiner Name		Unknown
Sheet	6	of	9	Atty Docket Number		CROSS1120-33
Examiner Initials	Cite No.	OTHER PRIOR ART -- NON PATENT LITERATURE DOCUMENTS				Date
	C106	Adaptec Schematics re AAC-340 (Kalwitz Ex 14 CNS 177215-251)) (CD-ROM Chaparral Exhibits D057)				
	C107	Bridge Product Line Review (Manzanares Ex 3 (CNS 177307-336)) (CD-ROM Chaparral Exhibits D058)				
	C108	AEC Bridge Series Products-Adaptec External Controller RAID Products Pre-Release Draft, v.6 (Manzanares Ex 4 (CNS 174632-653)). (CD-ROM Chaparral Exhibits D059)				10/28/1997
	C109	Hewlett-Packard Roseville Site Property Pass for Brian Smith (Dunning Ex 14 (HP 489) (CD-ROM Chaparral Exhibits D078)				11/7/1996
	C110	Distribution Agreement Between Hewlett-Packard and Crossroads (Dunning Ex 15 (HP 326-33) (CD-ROM Chaparral Exhibits D079)				
	C111	HPFC-5000 Tachyon User's Manuel, First Edition (PTI 172419-839) (CD-ROM Chaparral Exhibits D084)				5/1/1996
	C112	X3T10 994D - (Draft) Information Technology: SCSI-3 Architecture Model, Rev. 1.8 (PTI 165977) (CD-ROM Chaparral Exhibits D087)				
	C113	X3T10 Project 1047D: Information Technology- SCSI-3 Controller Commands (SCC), Rev, 6c (PTI 166400-546) (CD-ROM Chaparral Exhibits D088)				9/3/1996
	C114	X3T10 995D- (Draft) SCSI-3 Primary Commands, Rev. 11 (Wanamaker Ex 5 (PTI 166050-229)) (CD-ROM Chaparral Exhibits D089)				11/13/1996
	C115	VBAR Volume Backup and Restore (CRDS 12200-202) (CD-ROM Chaparral Exhibits D099)				
	C116	Preliminary Product Literature for Infinity Commstor's Fibre Channel to SCSI Protocol Bridge (Smith Ex 11; Quisenberry Ex 31 (SPLO 428-30) (CD-ROM Chaparral Exhibits D143)				8/19/1996
	C117	Letter dated 7/12/96 from J. Boykin to B. Smith re: Purchase Order for Evaluation Units from Crossroads (Smith Ex 24) CRDS 8556-57) (CD-ROM Chaparral Exhibits D144)				7/12/1996
	C118	CrossPoint 4100 Fibre Channel to SCSI Router Preliminary Datasheet (Hulsey Ex 9 (CRDS 16129-130)) (CD-ROM Chaparral Exhibits D145)				11/1/1996
	C119	CrossPoint 4400 Fibre Channel to SCSI Router Preliminary Datasheet (Bardach Ex. 9, Quisenberry Ex 33 (CRDS 25606-607)) (CD-ROM Chaparral Exhibits D153)				11/1/1996
	C120	Fax Dated 07/22/96 from L. Petti to B. Smith re: Purchase Order from Data General for FC2S Fibre to Channel SCSI Protocol Bridge Model 11 (Smith Ex 25; Quisenberry Ex 23; Bardach Ex 11 (CRDS 8552-55; 8558) (CD-ROM Chaparral Exhibits D155)				7/22/1996
	C121	Email Dated 12/20/96 from J. Boykin to B. Smith re: Purchase Order for Betas in February and March (Hoese Ex 16, Quisenberry Ex 25; Bardach Ex 12 (CRDS 13644-650) (CD-ROM Chaparral Exhibits D156)				12/20/1996
	C122	Infinity Commstor Fibre Channel Demo for Fall Comdex, 1996 (Hoese Ex 15, Bardach Ex 13 (CRDS 27415) (CD-ROM Chaparral Exhibits D157)				
Examiner Signature		/Christopher Shin/			Date Considered	08/26/2010

ALL REFERENCES CONSIDERED EXCEPT WHERE LINED THROUGH. /C.S./

INFORMATION DISCLOSURE STATEMENT				Application Number		12/690,592
				Filing Date		01/20/2010
				First Named Inventor		Geoffrey B. Hoese
				Group Art Unit		2111
				Examiner Name		Unknown
Sheet	7	of	9	Atty Docket Number		CROSS1120-33
Examiner Initials	Cite No.	OTHER PRIOR ART -- NON PATENT LITERATURE DOCUMENTS				Date
	C123	Fax Dated 12/19/96 from B. Bardach to T. Rarich re: Purchase Order Information (Bardach Ex. 14; Smith Ex 16 (CRDS 4460)) (CD-ROM Chaparral Exhibits D158)				12/19/1996
	C124	Miscellaneous Documents Regarding Comdex (Quisenberry Ex 2 (CRDS 27415-465)) (CD-ROM Chaparral Exhibits D165)				
	C125	CrossPoint 4100 Fibre Channel to SCSI Router Preliminary Datasheet (Quisenberry) Ex 3 (CRDS 4933-34) (CD-ROM Chaparral Exhibits D166) (CD-ROM Chaparral Exhibits D166)				
	C126	CrossPoint 4400 Fibre to Channel to SCSI Router Preliminary Datasheet; Crossroads Company and Product Overview (Quisenberry Ex 4 (CRDS 25606; 16136)) (CD-ROM Chaparral Exhibits D167)				
	C127	Crossroads Purchase Order Log (Quisenberry Ex 9 (CRDS 14061-062)) (CD-ROM Chaparral Exhibits D172)				
	C128	RAID Manager 5 with RDAC 5 for UNIX V.4 User's Guide (LSI-01854) (CD-ROM Chaparral Exhibits P062)				9/1/1996
	C129	Letter dated May 12, 1997 from Alan G. Leal to Barbara Bardach enclosing the original OEM License and Purchase Agreement between Hewlett-Package Company and Crossroads Systems, Inc. (CRDS 02057) (CD-ROM Chaparral Exhibits P130)				
	C130	CR4x00 Product Specification (CRDS 43929) (CD-ROM Chaparral Exhibits P267)				6/1/1998
	C131	Symbios Logic – Hardware Functional Specification for the Symbios Logic Series 3 Fibre Channel Disk Array Controller Model 3701 (Engelbrecht Ex 3 (LSI-1659-1733)) (CD-ROM Pathlight Exhibits D074)				
	C132	Report of the Working Group on Storage I/O for Large Scale Computing; Department of Computer Science Duke University: CS-1996-21 (PTI 173330-347). (CD-ROM Pathlight Exhibits D098)				
	C133	Brian Allison's 1999 Third Quarter Sales Plan (PDX 38)CNS 022120-132)) (CD-ROM Pathlight Exhibits D201)				6/5/2001
	C134	Brooklyn SCSI-SCSI Intelligent External RAID Bridge Definition Phase External Documentation ((CD-ROM Pathlight Exhibits D129)				
	C135	StorageWorks HSx70 System Specification by Steve Sicola dated 6/11/96 4:57pm, Revision 4.				6/11/1996
	C136	ANSI TR X3.xxx-199x, Revision 9 of X3-991D. Draft Proposed X3 Technical Report - Small Computer System Interface - 3 Generic Packetized Protocol (SCSI-GPP). Computer and Business Equipment Manufacturers Assoc.				
	C137	Enterprise Systems Connection (ESON) Implementation Guide, July 1996, IBM International Technical Support Organization, Poughkeepsie Center				7/1/1996
Examiner Signature		/Christopher Shin/			Date Considered	08/26/2010

ALL REFERENCES CONSIDERED EXCEPT WHERE LINED THROUGH. /C.S./

INFORMATION DISCLOSURE STATEMENT		Application Number		12/690,592		
		Filing Date		01/20/2010		
		First Named Inventor		Geoffrey B. Hoese		
		Group Art Unit		2111		
		Examiner Name		Unknown		
Sheet	8	of	9	Atty Docket Number	CROSS1120-33	
Examiner Initials	Cite No.	OTHER PRIOR ART -- NON PATENT LITERATURE DOCUMENTS			Date	
	C138	Digital Delivers Industry-Leading Enterprise-Class Storage Solutions. StorageWorks Family Provides Easiest Path to Fibre Channel. Three pages by Company News Oncall dated 09/09/04			9/9/2004	
	C139	American National Standard for Information Technology – Fibre Channel Protocol for SCSI. ANSI X3.269-1996			6/18/1905	
	C140	F1710A File Control Unit and F6493 Array Disk Subsystem by Hitoshi Matsushima, Shojiro Okada and Tetsuro Kudo.			2/3/1995	
	C141	The Legend of AMDAHL by Jeffrey L. Rodengen (5 pages)				
	C142	Office Action dated February 6, 2007 from the Japanese Patent Office regarding related application No. 526873/2000.			2/6/2007	
	C143	InfoServer 100 System Operation Guide, Order Number EK-DIS1K-UG-001				
	C144	iNFOsERVER 100 Installation and Owner's Guide, Order Number EK-DIS1K-IN-001				
	C145	Software Product Description: Product Name: InfoServer 100 Software, Version 1.1 SPD 38.59.00			11/1/1991	
	C146	Software Product Description: Product Name: InfoServer Client for ULTRIX, Version 1.1, SPD 40.78.01			4/1/1993	
	C147	Draft Proposed American National Standard. X3.269-199X, Revision 012. Information System - dpANS Fibre Channel Protocol fo SCSI.			12/4/1995	
	C148	Impactdata Launches Breakthrough Architecture for Network Storage.			11/13/1996	
	C149	Impactdata..News Release: Impactdata Introduces New Storage Architecture for High Performance Computing. 2 Pages.			11/12/1996	
	C150	Impactdata..News Release: Impactdata's Network Peripheral Adapter (NPA) Pushes Technology Envelope of Data Storage Management in High-Speed Computing Environments. 2 Pages.			11/12/1996	
	C151	Impactdata..News Release: Impactdata and Storage Concepts Announce Integration of FibreRAID II Storage Solution with Impactdata's Distributed Storage Node Architecture (DSNA). 2 pages.			11/18/1996	
	C152	Impactdata..News Release: Breece Hill Libraries Now Able to Attach Directly to High Speed Networks Peripheral Adapter from Impactdata. 2 Pages.			11/20/1996	
	C153	Impactdata - DSNA Questions and Answers. 22 Pages.				
	C154	Impactdata - Network Storage Solutions. 4 pages.				
	C155	Network Storage Building Blocks. 2 Pages.				
	C156	Impactdata - NPA (Network Peripheral Interface). 4 Pages				
	C157	Impactdata - CPI (Common Peripheral Interfae). 2 Pages				
	C158	Impactdata - SNC (Storage Node Controller). 2 Pages				
	C159	Impactdata - DSNA (Distributed Storage Node Architecture) Protocol. 2 Pages				
	C160	Impactdata - DS-50. 2 Pages				
	C161	Impactdata - Corporate Fact Sheet. 1 Page				
Examiner Signature		/Christopher Shin/			Date Considered	08/26/2010

ALL REFERENCES CONSIDERED EXCEPT WHERE LINED THROUGH. /C.S./

INFORMATION DISCLOSURE STATEMENT				Application Number	12/690,592
				Filing Date	01/20/2010
				First Named Inventor	Geoffrey B. Hoesel
				Group Art Unit	2111
				Examiner Name	Unknown
Sheet	9	of	9	Atty Docket Number	CROSS1120-33
Examiner Initials	Cite No.	OTHER PRIOR ART -- NON PATENT LITERATURE DOCUMENTS			Date
	C162	Raider-5 "Disk Array Manual for the UltraSCSI Controller". Part No. 261-0013-002. 191 Pages			
	C163	Impactdata - White Paper: Distributed Storage Node Architecture (DSNA). January, 1997			01/97
	C164	Impactdata - DSNA Distributed Storage Node Architecture "Reference Guide". 44 Pages			
	C165	F1710 Logic Specification			
	C166	Translation of Final Office Action issued in JP 526873/2000 mailed 05/14/08. 4 Pages.			5/14/2008
	C167	Office Action issued in USPA 11/851,837 dated 12/22/08, Hoesel, 7 pages			12/22/2008
	C168	English Translation of Japanese Laid-Open Publication No. 5-181609. 9 pgs.			7/23/1993
	C169	English Translation of Japanese Laid-Open Publication No. 7-20994. 57 pgs			1/24/1995
	C170	F1710 File Control Unit (FCU) Logical Specifications. 11 Pages			12/9/1997
Examiner Signature		/Christopher Shin/		Date Considered	08/26/2010

ALL REFERENCES CONSIDERED EXCEPT WHERE LINED THROUGH. /C.S./

	Type	Hits	Search Text	DBs
1	IS&R	6	((("7340549") or ("7051147") or ("6789152") or ("6421753") or ("5941972") or ("20080307444")).PN.	US-PG PUB; USPAT
2	BRS	175	crossroads.as.	US-PG PUB; USPAT; USOCR; FPRS; EPO; JPO; DERWENT; IBM_TDB
3	BRS	21357	geoffrey.in.	US-PG PUB; USPAT; USOCR; FPRS; EPO; JPO; DERWENT; IBM_TDB
4	BRS	119	storage and S2	US-PG PUB; USPAT; USOCR; FPRS; EPO; JPO; DERWENT; IBM_TDB
5	BRS	84	router and S5	US-PG PUB; USPAT; USOCR; FPRS; EPO; JPO; DERWENT; IBM_TDB
6	BRS	176	crossroads.as.	US-PG PUB; USPAT; USOCR; FPRS; EPO; JPO; DERWENT; IBM_TDB
7	BRS	21454	geoffrey.in.	US-PG PUB; USPAT; USOCR; FPRS; EPO; JPO; DERWENT; IBM_TDB
8	BRS	24	S7 and S8	US-PG PUB; USPAT; USOCR; FPRS; EPO; JPO; DERWENT; IBM_TDB
9	IS&R	3	((("7051147") or ("6738854") or ("6425035")).PN.	US-PG PUB; USPAT

	Time Stamp	Comments	Error Definition	Errors	Ref #
1	2010/07/22 15:13				S1
2	2010/07/22 15:14				S2
3	2010/07/22 15:15				S3
4	2010/07/22 15:15				S5
5	2010/07/22 15:15				S6
6	2010/08/25 15:35				S7
7	2010/08/25 15:35				S8
8	2010/08/25 15:35				S9
9	2010/09/08 12:21				S10

INFORMATION DISCLOSURE STATEMENT				Application Number	12/690,592
				Filing or 371 (c) Date:	January 20, 2010
				First Named Inventor	Geoffrey B. Hoese
				Group Art Unit	2182
				Examiner Name	Unknown
Sheet	1	of	1	Atty Docket Number	CROSS1120-33
NON PATENT LITERATURE DOCUMENTS					
Examiner Initials	Cite No.	Include name of the author (in CAPITAL LETTERS), title of the article (when appropriate), title of the item (book, magazine, journal, serial, symposium, catalog, etc.) date, page(s), volume-issue number(s), publisher, city and/or country where published			T²
	C172	QUESTIONING Mailed 06/08/2010 from JP Patent Application 526873/2000. 8 pages			06/08/10
	C173	Office Action Mailed 08/17/2010 in U.S. Serial No. 11/947,499 to Hoese. 6 pgs.			08/17/10
Examiner Signature	/Christopher Shin/			Date Considered	09/09/2010

ALL REFERENCES CONSIDERED EXCEPT WHERE LINED THROUGH. /C.S./

INFORMATION DISCLOSURE STATEMENT				Application Number	12/690,592
				Filing or 371 (c) Date:	January 20, 2010
				First Named Inventor	Geoffrey B. Hoese
				Group Art Unit	2182
				Examiner Name	Unknown
Sheet	1	of	1	Atty Docket Number	CROSS1120-33
NON PATENT LITERATURE DOCUMENTS					
Examiner Initials	Cite No.	Include name of the author (in CAPITAL LETTERS), title of the article (when appropriate), title of the item (book, magazine, journal, serial, symposium, catalog, etc.) date, page(s), volume-issue number(s), publisher, city and/or country where published			T²
	C171	American National Standard for Information Systems: Fibre Channel -- Cross-Point Switch Fabric Topology (FC-XS); X3T11/Project 959D/Rev 1.30. 114 pgs.			6/17/1994
Examiner Signature	/Christopher Shin/			Date Considered	08/26/2010

ALL REFERENCES CONSIDERED EXCEPT WHERE LINED THROUGH. /C.S./



UNITED STATES PATENT AND TRADEMARK OFFICE

UNITED STATES DEPARTMENT OF COMMERCE
 United States Patent and Trademark Office
 Address: COMMISSIONER FOR PATENTS
 P.O. Box 1450
 Alexandria, Virginia 22313-1450
 www.uspto.gov

BIB DATA SHEET

CONFIRMATION NO. 8115

SERIAL NUMBER	FILING or 371(c) DATE	CLASS	GROUP ART UNIT	ATTORNEY DOCKET NO.		
12/690,592	01/20/2010	710	2181	CROSS1120-33		
RULE						
APPLICANTS Geoffrey B. Hoese, Austin, TX; Jeffry T. Russell, Cibolo, TX;						
** CONTINUING DATA ***** This application is a CON of 12/552,885 09/02/2009 which is a CON of 11/851,724 09/07/2007 PAT 7,689,754 which is a CON of 11/442,878 05/30/2006 ABN * which is a CON of 11/353,826 02/14/2006 PAT 7,340,549 which is a CON of 10/658,163 09/09/2003 PAT 7,051,147 which is a CON of 10/081,110 02/22/2002 PAT 6,789,152 which is a CON of 09/354,682 07/15/1999 PAT 6,421,753 which is a CON of 09/001,799 12/31/1997 PAT 5,941,972 (*)Data provided by applicant is not consistent with PTO records.						
** FOREIGN APPLICATIONS *****						
** IF REQUIRED, FOREIGN FILING LICENSE GRANTED ** 02/02/2010						
Foreign Priority claimed <input type="checkbox"/> Yes <input checked="" type="checkbox"/> No	35 USC 119(a-d) conditions met <input type="checkbox"/> Yes <input checked="" type="checkbox"/> No	<input type="checkbox"/> Met after Allowance	STATE OR COUNTRY	SHEETS DRAWINGS	TOTAL CLAIMS	INDEPENDENT CLAIMS
Verified and /CHRISTOPHER B SHIN/	Examiner's Signature	Initials	TX	2	53	3
ADDRESS SPRINKLE IP LAW GROUP 1301 W. 25TH STREET SUITE 408 AUSTIN, TX 78705 UNITED STATES						
TITLE STORAGE ROUTER AND METHOD FOR PROVIDING VIRTUAL LOCAL STORAGE						
FILING FEE RECEIVED 2806	FEES: Authority has been given in Paper No. _____ to charge/credit DEPOSIT ACCOUNT No. _____ for following:		<input type="checkbox"/> All Fees <input type="checkbox"/> 1.16 Fees (Filing) <input type="checkbox"/> 1.17 Fees (Processing Ext. of time) <input type="checkbox"/> 1.18 Fees (Issue) <input type="checkbox"/> Other _____ <input type="checkbox"/> Credit			

IN THE UNITED STATES PATENT AND TRADEMARK OFFICE	
INFORMATION DISCLOSURE STATEMENT BY APPLICANT	Atty. Docket No. (Opt.) CROSS1120-33
	Applicant Geoffrey B. Hoese
Application Number 12/690,592	Filing or 371 (c) Date: January 20, 2010
For STORAGE ROUTER AND METHOD FOR PROVIDING VIRTUAL LOCAL STORAGE	
Group Art Unit 2182	Examiner Unknown
Confirmation Number: 8115	

Commissioner for Patents
P.O. Box 1450
Alexandria, VA 22313-1450

Dear Sir,

<u>Certification of Transmission Under 37 C.F.R. 1.8</u>
I hereby certify that this correspondence is being transmitted to the Commissioner for Patents, P.O. Box 1450, Alexandria, VA 22312-1450 via the U.S. Patent and Trademark Office Electronic Filing System (EFS-Web) on <u>8/20/10</u> 2010.
 Janice Pampell

Applicant respectfully requests, pursuant to 37 C.F.R. §§ 1.56, 1.97 and 1.98, that the information listed on the attached SB08A/B form(s) be considered and cited in the examination of the above-identified application. A copy of U.S. Patent(s) and U.S. Patent Application Publication(s) listed on the attached SB08A form is not being submitted with this Information Disclosure Statement pursuant to the waiver of 37 C.F.R. § 1.98(a)(2)(i) by the U.S. Patent and Trademark Office. A copy of foreign patent documents as well as the information listed on the attached SB08B form is enclosed for the convenience of the Examiner.

This Information Disclosure Statement is being submitted within three months of the filing date of a national application other than a continued prosecution application under 37 C.F.R. § 1.53(d).

This Information Disclosure Statement is being submitted within three months of the date of entry of the national stage as set forth in 37 C.F.R. § 1.491 in an international application;

This Information Disclosure Statement is being submitted before the mailing of a first Office action on the merits; or

This Information Disclosure Statement is being submitted before the mailing of a first Office action after the filing of a request for continued examination under 37 C.F.R. § 1.114.

This Information Disclosure Statement is being submitted after the period specified in 37 C.F.R. § 1.97(b) and before the mailing date of any of a final action under 37 C.F.R. § 1.113, a notice of allowance under 37 C.F.R. § 1.311, or an action that otherwise closes prosecution in the application, and is accompanied by one of:

- The statement specified in 37 C.F.R. § 1.97(e); or
- The fee set forth in 37 C.F.R. § 1.17(p). Applicant hereby authorizes the Commissioner to deduct the amount of \$180 from Deposit Account No. 50-3183 of Sprinkle IP Law Group for the filing fee of this Information Disclosure Statement.

This Information Disclosure Statement is being submitted after the period specified in 37 C.F.R. § 1.97(c) and on or before payment of the issue fee and is accompanied by:

- The statement specified in 37 C.F.R. § 1.97(e); and
- The fee set forth in 37 C.F.R. § 1.17(p). Applicant hereby authorizes the Commissioner to deduct the amount of \$180 from Deposit Account No. 50-3183 of Sprinkle IP Law Group for the filing fee of this Information Disclosure Statement.

Applicant does not believe any fees are due for filing this Information Disclosure Statement; however, if Applicant is in error, the Director is hereby authorized to deduct any and all appropriate fees from Deposit Account 50-3183 of Sprinkle IP Law Group. Applicant respectfully submits that the claims of Applicant's above-referenced patent application are patentably distinguishable from the listed information.

Respectfully submitted,

Sprinkle IP Law Group
Attorneys for Applicant

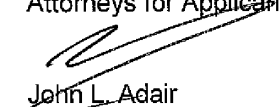
John L. Adair
Reg. No. 48,828

Dated: Aug 20, 2010

1301 W. 25th Street, Suite 408
Austin, Texas 78705
Tel. (512) 637-9220
Fax. (512) 317-9088

INFORMATION DISCLOSURE STATEMENT			Application Number	12/690,592	
			Filing or 371 (c) Date:	January 20, 2010	
			First Named Inventor	Geoffrey B. Hoese	
			Group Art Unit	2182	
			Examiner Name	Unknown	
Sheet	1	of	1	Atty Docket Number	CROSS1120-33
NON PATENT LITERATURE DOCUMENTS					
Examiner Initials	Cite No.	Include name of the author (in CAPITAL LETTERS), title of the article (when appropriate), title of the item (book, magazine, journal, serial, symposium, catalog, etc.) date, page(s), volume-issue number(s), publisher, city and/or country where published			T²
	C172	QUESTIONING Mailed 06/08/2010 from JP Patent Application 526873/2000. 8 pages			06/08/10
	C173	Office Action Mailed 08/17/2010 in U.S. Serial No. 11/947,499 to Hoese. 6 pgs.			08/17/10
Examiner Signature				Date Considered	

Electronic Acknowledgement Receipt

EFS ID:	8262176
Application Number:	12690592
International Application Number:	
Confirmation Number:	8115
Title of Invention:	STORAGE ROUTER AND METHOD FOR PROVIDING VIRTUAL LOCAL STORAGE
First Named Inventor/Applicant Name:	Geoffrey B. Hoese
Customer Number:	44654
Filer:	John L. Adair/Janice Pampell
Filer Authorized By:	John L. Adair
Attorney Docket Number:	CROSS1120-33
Receipt Date:	20-AUG-2010
Filing Date:	20-JAN-2010
Time Stamp:	17:26:49
Application Type:	Utility under 35 USC 111(a)

Payment information:

Submitted with Payment	no
------------------------	----

File Listing:

Document Number	Document Description	File Name	File Size(Bytes)/ Message Digest	Multi Part /.zip	Pages (if appl.)
1	Information Disclosure Statement (IDS) Filed (SB/08)	CROSS1120-33_IDS_Filed_08-20-10.pdf	78419 <small>ca3556359c8fac70e9f21e417262198ec9535b507</small>	no	3

Warnings:

Information:

This is not an USPTO supplied IDS fillable form

2	NPL Documents	CROSS1120_Ref_C172.pdf	197554	no	8
			f69f3813c29e318b796ff0f186ce0dd9b5f3b5d4		

Warnings:

Information:

3	NPL Documents	CROSS1120_Ref_C173.pdf	175870	no	7
			2f518144450f3e34d8d4f7cab7c7ea31971be6085		

Warnings:

Information:

Total Files Size (in bytes):	451843
-------------------------------------	--------

This Acknowledgement Receipt evidences receipt on the noted date by the USPTO of the indicated documents, characterized by the applicant, and including page counts, where applicable. It serves as evidence of receipt similar to a Post Card, as described in MPEP 503.

New Applications Under 35 U.S.C. 111

If a new application is being filed and the application includes the necessary components for a filing date (see 37 CFR 1.53(b)-(d) and MPEP 506), a Filing Receipt (37 CFR 1.54) will be issued in due course and the date shown on this Acknowledgement Receipt will establish the filing date of the application.

National Stage of an International Application under 35 U.S.C. 371

If a timely submission to enter the national stage of an international application is compliant with the conditions of 35 U.S.C. 371 and other applicable requirements a Form PCT/DO/EO/903 indicating acceptance of the application as a national stage submission under 35 U.S.C. 371 will be issued in addition to the Filing Receipt, in due course.

New International Application Filed with the USPTO as a Receiving Office

If a new international application is being filed and the international application includes the necessary components for an international filing date (see PCT Article 11 and MPEP 1810), a Notification of the International Application Number and of the International Filing Date (Form PCT/RO/105) will be issued in due course, subject to prescriptions concerning national security, and the date shown on this Acknowledgement Receipt will establish the international filing date of the application.

INFORMATION DISCLOSURE STATEMENT				Application Number	12/690,592
				Filing or 371 (c) Date:	January 20, 2010
				First Named Inventor	Geoffrey B. Hoese
				Group Art Unit	2182
				Examiner Name	Unknown
Sheet	1	of	1	Atty Docket Number	CROSS1120-33
NON PATENT LITERATURE DOCUMENTS					
Examiner Initials	Cite No.	Include name of the author (in CAPITAL LETTERS), title of the article (when appropriate), title of the item (book, magazine, journal, serial, symposium, catalog, etc.) date, page(s), volume-issue number(s), publisher, city and/or country where published			T²
	C171	American National Standard for Information Systems: Fibre Channel -- Cross-Point Switch Fabric Topology (FC-XS); X3T11/Project 959D/Rev 1.30. 114 pgs.			6/17/1994
Examiner Signature				Date Considered	

Electronic Acknowledgement Receipt

EFS ID:	7781273
Application Number:	12690592
International Application Number:	
Confirmation Number:	8115
Title of Invention:	STORAGE ROUTER AND METHOD FOR PROVIDING VIRTUAL LOCAL STORAGE
First Named Inventor/Applicant Name:	Geoffrey B. Hoese
Customer Number:	44654
Filer:	John L. Adair/Betty Caldwell
Filer Authorized By:	John L. Adair
Attorney Docket Number:	CROSS1120-33
Receipt Date:	09-JUN-2010
Filing Date:	20-JAN-2010
Time Stamp:	17:18:03
Application Type:	Utility under 35 USC 111(a)

Payment information:

Submitted with Payment	no
------------------------	----

File Listing:

Document Number	Document Description	File Name	File Size(Bytes)/ Message Digest	Multi Part /.zip	Pages (if appl.)
1		CROSS1120-33_IDS_06-09-10.pdf	115678 <small>51aa5fa515cd40221bf9b52d7d5acc2729951a66</small>	yes	3

Multipart Description/PDF files in .zip description					
Document Description			Start	End	
Transmittal Letter			1	2	
Information Disclosure Statement (IDS) Filed (SB/08)			3	3	
Warnings:					
Information:					
2	NPL Documents	CROSS1120_Ref_C171.pdf	3613973	no	114
			d445cf43c5f3deb791444e7c7c7f749b39c b156		
Warnings:					
Information:					
Total Files Size (in bytes):			3729651		
<p>This Acknowledgement Receipt evidences receipt on the noted date by the USPTO of the indicated documents, characterized by the applicant, and including page counts, where applicable. It serves as evidence of receipt similar to a Post Card, as described in MPEP 503.</p> <p><u>New Applications Under 35 U.S.C. 111</u> If a new application is being filed and the application includes the necessary components for a filing date (see 37 CFR 1.53(b)-(d) and MPEP 506), a Filing Receipt (37 CFR 1.54) will be issued in due course and the date shown on this Acknowledgement Receipt will establish the filing date of the application.</p> <p><u>National Stage of an International Application under 35 U.S.C. 371</u> If a timely submission to enter the national stage of an international application is compliant with the conditions of 35 U.S.C. 371 and other applicable requirements a Form PCT/DO/EO/903 indicating acceptance of the application as a national stage submission under 35 U.S.C. 371 will be issued in addition to the Filing Receipt, in due course.</p> <p><u>New International Application Filed with the USPTO as a Receiving Office</u> If a new international application is being filed and the international application includes the necessary components for an international filing date (see PCT Article 11 and MPEP 1810), a Notification of the International Application Number and of the International Filing Date (Form PCT/RO/105) will be issued in due course, subject to prescriptions concerning national security, and the date shown on this Acknowledgement Receipt will establish the international filing date of the application.</p>					

IN THE UNITED STATES PATENT AND TRADEMARK OFFICE	
INFORMATION DISCLOSURE STATEMENT BY APPLICANT	Atty. Docket No. (Opt.) CROSS1120-33
	Applicant Geoffrey B. Hoese
Application Number 12/690,592	Filing or 371 (c) Date: January 20, 2010
For STORAGE ROUTER AND METHOD FOR PROVIDING VIRTUAL LOCAL STORAGE	
Group Art Unit 2182	Examiner Unknown
Confirmation Number: 8115	

Commissioner for Patents
P.O. Box 1450
Alexandria, VA 22313-1450

Dear Sir,

Certification of Transmission Under 37 C.F.R. 1.8
I hereby certify that this correspondence is being transmitted to the Commissioner for Patents, P.O. Box 1450, Alexandria, VA 22312-1450 via the U.S. Patent and Trademark Office Electronic Filing System (EFS-Web) on <u>June 9</u> 2010.
 Betty Caldwell

Applicant respectfully requests, pursuant to 37 C.F.R. §§ 1.56, 1.97 and 1.98, that the information listed on the attached SB08A/B form(s) be considered and cited in the examination of the above-identified application. A copy of U.S. Patent(s) and U.S. Patent Application Publication(s) listed on the attached SB08A form is not being submitted with this Information Disclosure Statement pursuant to the waiver of 37 C.F.R. § 1.98(a)(2)(i) by the U.S. Patent and Trademark Office. A copy of foreign patent documents as well as the information listed on the attached SB08B form is enclosed for the convenience of the Examiner.

This Information Disclosure Statement is being submitted within three months of the filing date of a national application other than a continued prosecution application under 37 C.F.R. § 1.53(d).

This Information Disclosure Statement is being submitted within three months of the date of entry of the national stage as set forth in 37 C.F.R. § 1.491 in an international application;

This Information Disclosure Statement is being submitted before the mailing of a first Office action on the merits; or

This Information Disclosure Statement is being submitted before the mailing of a first Office action after the filing of a request for continued examination under 37 C.F.R. § 1.114.

This Information Disclosure Statement is being submitted after the period specified in 37 C.F.R. § 1.97(b) and before the mailing date of any of a final action under 37 C.F.R. § 1.113, a notice of allowance under 37 C.F.R. § 1.311, or an action that otherwise closes prosecution in the application, and is accompanied by one of:

- The statement specified in 37 C.F.R. § 1.97(e); or
- The fee set forth in 37 C.F.R. § 1.17(p). Applicant hereby authorizes the Commissioner to deduct the amount of \$180 from Deposit Account No. 50-3183 of Sprinkle IP Law Group for the filing fee of this Information Disclosure Statement.

This Information Disclosure Statement is being submitted after the period specified in 37 C.F.R. § 1.97(c) and on or before payment of the issue fee and is accompanied by:

- The statement specified in 37 C.F.R. § 1.97(e); and
- The fee set forth in 37 C.F.R. § 1.17(p). Applicant hereby authorizes the Commissioner to deduct the amount of \$180 from Deposit Account No. 50-3183 of Sprinkle IP Law Group for the filing fee of this Information Disclosure Statement.

Applicant does not believe any fees are due for filing this Information Disclosure Statement; however, if Applicant is in error, the Director is hereby authorized to deduct any and all appropriate fees from Deposit Account 50-3183 of Sprinkle IP Law Group. Applicant respectfully submits that the claims of Applicant's above-referenced patent application are patentably distinguishable from the listed information.

Respectfully submitted,

Sprinkle IP Law Group
Attorneys for Applicant

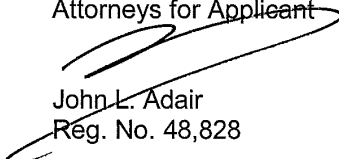
John L. Adair
Reg. No. 48,828

Dated: June 8

1301 W. 25th Street, Suite 408
Austin, Texas 78705
Tel. (512) 637-9220
Fax. (512) 317-9088



**INFORMATION DISCLOSURE
STATEMENT BY APPLICANT**

Application Number	12/690,592
Filing Date	01/20/2010
First Named Inventor	Geoffrey B. Hoese
Group Art Unit	2111
Examiner Name	Unknown
Attorney Docket Number	CROSS1120-33

Sheet **1** of **9**

U.S. PATENT DOCUMENTS

Examiner Initials	Cite No.	Document Number	Publication Date MM-DD-YYYY	Name of Patentee or Applicant of Cited Document	Pages, Columns, Lines Where Relevant Passages or Figures Appear
		Number-Kind Code (if known)			
	A1	3,082,406	3/19/1963	L.D. Stevens	
	A2	4,092,732	5/30/1978	Ouchi	
	A3	4,170,415	10/9/1979	Lemeshewsky, et al.	
	A4	4,415,970	11/15/1983	Swenson, et al.	
	A5	4,455,605	6/19/1984	Cormier, et al.	
	A6	4,504,927	3/12/1985	Callan	
	A7	4,533,996	8/6/1985	Gartung, et al.	
	A8	4,573,152	2/25/1986	Greene, et al.	
	A9	4,603,380	7/29/1986	Easton, et al.	
	A10	4,620,295	10/28/1986	Aiden, Jr.	
	A11	4,644,462	2/17/1987	Matsubara, et al.	
	A12	4,695,948	9/22/1987	Blevins, et al.	
	A13	4,697,232	9/29/1987	Brunelle, et al.	
	A14	4,715,030	12/22/1987	Koch, et al.	
	A15	4,751,635	6/14/1988	Kret	
	A16	4,787,028	11/22/1988	Finforck, et al.	
	A17	4,807,180	2/21/1989	Takeuchi, et al.	
	A18	4,811,278	3/7/1989	Bean, et al.	
	A19	4,821,179	4/11/1989	Jensen, et al.	
	A20	4,825,406	4/25/1989	Bean, et al.	
	A21	4,827,411	5/2/1989	Arrowood, et al.	
	A22	4,835,674	5/30/1989	Collins, et al.	
	A23	4,845,722	7/4/1989	Kent et al.	
	A24	4,864,532	9/5/1989	Reeve, et al.	
	A25	4,897,874	1/30/1990	Lidensky, et al.	
	A26	4,947,367	8/7/1990	Chang, et al.	
	A27	4,961,224	10/2/1990	Yung	
	A28	5,072,378	12/10/1991	Manka	
	A29	5,077,732	12/31/1991	Fischer, et al.	
	A30	5,077,736	12/31/1991	Dunphy, Jr., et al.	
	A31	5,124,987	6/23/1992	Milligan, et al.	
	A32	5,155,845	10/13/1992	Beal, et al.	
	A33	5,163,131	11/10/1992	Row, et al.	
	A34	5,185,876	2/9/1993	Nguyen, et al.	
	A35	5,193,168	3/9/1993	Corrigan, et al.	
	A36	5,193,184	3/9/1993	Belsan, et al.	
	A37	5,202,856	4/13/1993	Glider, et al.	
	A38	5,210,866	5/11/1993	Milligan, et al.	
Examiner Signature				Date Considered	

INFORMATION DISCLOSURE STATEMENT BY APPLICANT				Application Number	12/690,592	
				Filing Date	01/20/2010	
				First Named Inventor	Geoffrey B. Hoese	
				Group Art Unit	2111	
				Examiner Name	Unknown	
Sheet	2	of	9	Attorney Docket Number	CROSS1120-33	
U.S. PATENT DOCUMENTS						
Examiner Initials	Cite No.	Document Number		Publication Date MM-DD-YYYY	Name of Patentee or Applicant of Cited Document	Pages, Columns, Lines Where Relevant Passages or Figures Appear
		Number-Kind Code (if known)				
	A39	5,212,785		5/18/1993	Powers, et al.	
	A40	5,214,778		5/25/1993	Glider, et al.	
	A41	5,226,143		7/6/1993	Baird, et al.	
	A42	5,239,632		8/24/1993	Larner	
	A43	5,239,643		8/24/1993	Blount, et al.	
	A44	5,239,654		8/24/1993	Ing-Simmons, et al.	
	A45	5,247,638		9/21/1993	O'Brien, et al.	
	A46	5,247,692		9/21/1993	Fujimura	
	A47	5,257,386		10/26/1993	Saito	
	A48	5,297,262		3/22/1994	Cox, et al.	
	A49	5,301,290		4/5/1994	Tetzlaff, et al.	
	A50	5,315,657		5/24/1994	Abadi, et al.	
	A51	5,317,693		5/31/1994	Elko, et al.	
	A52	5,331,673		7/19/1994	Elko, et al.	
	A53	5,347,384		9/13/1994	McReynolds, et al.	
	A54	5,355,453		10/11/1994	Glider, et al.	
	A55	5,361,347		11/1/1994	Glider, et al.	
	A56	5,367,646		11/22/1994	Pardillos, et al.	
	A57	5,379,385		1/3/1995	Shomler	
	A58	5,379,398		1/3/1995	Cohn, et al.	
	A59	5,388,243		2/7/1995	Glider, et al.	
	A60	5,388,246		2/7/1995	Kasi	
	A61	5,394,402		2/28/1995	Ross, et al.	
	A62	5,394,526		2/28/1995	Crouse et al.	
	A63	5,396,596		3/7/1995	Hashemi, et al.	
	A64	5,403,639		4/4/1995	Belsan, et al.	
	A65	5,410,667		4/25/1995	Belsan, et al.	
	A66	5,410,697		4/25/1995	Baird, et al.	
	A67	5,414,820		10/9/1995	McFarland, et al.	
	A68	5,416,915		5/16/1995	Mattson, et al.	
Examiner Signature					Date Considered	

INFORMATION DISCLOSURE STATEMENT BY APPLICANT				Application Number	12/690,592	
				Filing Date	01/20/2010	
				First Named Inventor	Geoffrey B. Hoese	
				Group Art Unit	2111	
				Examiner Name	Unknown	
Sheet	3	of	9	Attorney Docket Number	CROSS1120-33	
U.S. PATENT DOCUMENTS						
Examiner Initials	Cite No.	Document Number		Publication Date MM-DD-YYYY	Name of Patentee or Applicant of Cited Document	Pages, Columns, Lines Where Relevant Passages or Figures Appear
		Number-Kind Code (if known)				
	A69	5,418,909		5/23/1995	Jachowski, et al.	
	A70	5,420,988		5/30/1995	Elliott	
	A71	5,423,026		6/6/1995	Cook, et al.	
	A72	5,423,044		6/6/1995	Sutton, et al.	
	A73	5,426,637		6/20/1995	Derby, et al.	
	A74	5,430,855		7/4/1995	Wash, et al.	
	A75	5,450,570		9/12/1995	Richek, et al.	
	A76	5,452,421		9/19/1995	Beardsley, et al.	
	A77	5,459,857		10/17/1995	Ludlam, et al.	
	A78	5,463,754		10/31/1995	Beausoleil, et al.	
	A79	5,465,382		11/7/1995	Day, III, et al.	
	A80	5,469,576		11/21/1995	Dauerer, et al.	
	A81	5,471,609		11/28/1995	Yudenfriend, et al.	
	A82	5,487,077		1/23/1996	Hassner, et al.	
	A83	5,491,812		2/13/1996	Pisello, et al.	
	A84	5,495,474		2/27/1996	Olnowich, et al.	
	A85	5,496,576		3/5/1996	Jeong	
	A86	5,504,857		4/2/1996	Baird, et al.	
	A87	5,507,032		4/9/1996	Kimura	
	A88	5,511,169		4/23/1996	Suda	
	A89	5,519,695		5/21/1996	Purohit, et al.	
	A90	5,530,845		6/25/1996	Hiatt, et al.	
	A91	5,535,352		7/9/1996	Bridges, et al.	
	A92	5,537,585		7/16/1996	Blickerstaff, et al.	
	A93	5,544,313		8/6/1996	Shachnai, et al.	
	A94	5,548,791		8/20/1996	Casper, et al.	
	A95	5,564,019		10/8/1996	Beausoleil, et al.	
	A96	5,568,648		10/22/1996	Coscarella, et al.	
	A97	5,581,709		12/3/1996	Ito, et al.	
	A98	5,581,714		12/3/1996	Amini, et al.	
Examiner Signature				Date Considered		

INFORMATION DISCLOSURE STATEMENT BY APPLICANT				Application Number	12/690,592	
				Filing Date	01/20/2010	
				First Named Inventor	Geoffrey B. Hoese	
				Group Art Unit	2111	
				Examiner Name	Unknown	
Sheet	4	of	9	Attorney Docket Number	CROSS1120-33	
U.S. PATENT DOCUMENTS						
Examiner Initials	Cite No.	Document Number		Publication Date MM-DD-YYYY	Name of Patentee or Applicant of Cited Document	Pages, Columns, Lines Where Relevant Passages or Figures Appear
		Number-Kind Code (if known)				
	A99	5,581,724		12/3/1996	Belsan et al.	
	A100	5,596,562		6/21/1997	Chen	
	A101	5,596,736		1/21/1997	Kerns	
	A102	5,598,541		1/28/1997	Malladi	
	A103	5,613,082		3/18/1997	Brewer, et al.	
	A104	5,621,902		4/15/1997	Cases, et al.	
	A105	5,632,012		5/20/1997	Belsan, et al.	
	A106	5,634,111		5/27/1997	Oeda, et al.	
	A107	5,638,518		6/10/1997	Malladi	
	A108	5,642,515		6/24/1997	Jones, et al.	
	A109	5,659,756		8/19/1997	Hefferon, et al.	
	A110	5,664,107		9/2/1997	Chatwanni, et al.	
	A111	5,680,556		10/21/1997	Begun, et al.	
	A112	5,684,800		11/4/1997	Dobbins, et al.	
	A113	5,701,491		12/23/1997	Dunn, et al.	
	A114	5,712,976		1/27/1998	Falcon, et al.	
	A115	5,727,218		3/10/1998	Hotchkin	
	A116	5,729,705		3/17/1998	Weber	
	A117	5,743,847		4/28/1998	Nakamura, et al.	
	A118	5,748,924		5/5/1998	Llorens, et al.	
	A119	5,571,971		5/12/1998	Dobbins, et al.	
	A120	5,751,975		5/12/1998	Gillespie, et al.	
	A121	5,764,931		6/9/1998	Schmahl, et al.	
	A122	5,768,623		6/16/1998	Judd, et al.	
	A123	5,774,683		6/30/1998	Gulick	
	A124	5,778,411		7/7/1998	DeMoss	
	A125	5,781,715		7/14/1998	Sheu	
	A126	5,802,278		9/1/1998	Isfeld, et al.	
	A127	5,805,816		9/8/1998	Picazo, Jr., et al.	
	A128	5,805,920		9/8/1998	Sprenkle, et al.	
Examiner Signature					Date Considered	

INFORMATION DISCLOSURE STATEMENT BY APPLICANT				Application Number	12/690,592	
				Filing Date	01/20/2010	
				First Named Inventor	Geoffrey B. Hoese	
				Group Art Unit	2111	
				Examiner Name	Unknown	
Sheet	5	of	9	Attorney Docket Number	CROSS1120-33	
U.S. PATENT DOCUMENTS						
Examiner Initials	Cite No.	Document Number		Publication Date MM-DD-YYYY	Name of Patentee or Applicant of Cited Document	Pages, Columns, Lines Where Relevant Passages or Figures Appear
		Number-Kind Code (if known)				
	A129	5,809,328		9/15/1998	Nogales, et al.	
	A130	5,812,754		9/22/1998	Lui, et al.	
	A131	5,819,054		10/6/1998	Ninomiya, et al.	
	A132	5,825,772		10/20/1998	Dobbins, et al.	
	A133	5,835,496		11/10/1998	Yeung, et al.	
	A134	5,845,107		12/1/1998	Fisch, et al.	
	A135	5,848,251		12/8/1998	Lomelino, et al.	
	A136	5,857,080		10/5/1999	Jander, et al.	
	A137	5,860,137		1/12/1999	Raz, et al.	
	A138	5,864,653		1/26/1999	Tavallaee, et al.	
	A139	5,867,648		2/2/1999	Foth, et al.	
	A140	5,884,027		3/16/1999	Garbus, et al.	
	A141	5,889,952		3/30/1999	Hunnicutt, et al.	
	A142	5,913,045		6/15/1999	Gillespie, et al.	
	A143	5,923,557		7/13/1999	Eidson	
	A144	5,933,824		8/3/1999	DeKoning, et al.	
	A145	5,935,205		8/10/1999	Murayama, et al.	
	A146	5,935,260		8/10/1999	Ofer	
	A147	5,941,969		8/24/1999	Ram, et al.	
	A148	5,941,972		8/24/1999	Hoese, et al.	
	A149	5,946,308		8/31/1999	Dobbins, et al.	
	A150	5,953,511		9/14/1999	Sescilia, et al.	
	A151	5,959,994		9/28/1999	Boggs, et al.	
	A152	5,963,556		10/5/1999	Varghese, et al.	
	A153	5,974,530		10/26/1999	Young	
	A154	5,978,379		11/2/1999	Chan, et al.	
	A155	5,978,875		11/2/1999	Asano, et al.	
	A156	5,991,797		11/23/1999	Futral, et al.	
	A157	6,000,020		12/7/1999	Chin, et al.	
	A158	6,041,058		3/21/2000	Flanders, et al.	
Examiner Signature				Date Considered		

INFORMATION DISCLOSURE STATEMENT BY APPLICANT				Application Number	12/690,592	
				Filing Date	01/20/2010	
				First Named Inventor	Geoffrey B. Hoese	
				Group Art Unit	2111	
				Examiner Name	Unknown	
Sheet	6	of	9	Attorney Docket Number	CROSS1120-33	
U.S. PATENT DOCUMENTS						
Examiner Initials	Cite No.	Document Number		Publication Date MM-DD-YYYY	Name of Patentee or Applicant of Cited Document	Pages, Columns, Lines Where Relevant Passages or Figures Appear
		Number-Kind Code (if known)				
	A159	6,021,451		2/1/2000	Bell, et al.	
	A160	6,029,168		2/22/2000	Frey	
	A161	6,032,269		2/29/2000	Renner, Jr.	
	A162	6,041,381		3/21/2000	Hoese	
	A163	6,055,603		4/25/2000	Ofer, et al.	
	A164	6,065,087		5/16/2000	Keaveny, et al.	
	A165	6,070,253		5/30/2000	Tavallaei, et al.	
	A166	6,073,209		6/6/2000	Bergsten	
	A167	6,073,218		6/6/2000	DeKoning, et al.	
	A168	6,075,863		6/13/2000	Krishnan, et al.	
	A169	6,081,849		6/27/2000	Born, et al.	
	A170	6,098,128		8/1/2000	Velez-McCaskey et al.	
	A171	6,098,149		8/1/2000	Ofer, et al.	
	A172	6,108,684		8/22/2000	DeKoning, et al.	
	A173	6,118,766		9/12/2000	Akers	
	A174	6,131,119		10/10/2000	Fukui	
	A175	6,134,617		10/17/2000	Weber	
	A176	6,141,737		10/31/2000	Krantz, et al.	
	A177	6,145,006		11/7/2000	Vishlitsky, et al.	
	A178	6,147,976		11/14/2000	Shand, et al.	
	A179	6,147,995		11/14/2000	Dobbins, et al.	
	A180	6,148,004		11/14/2000	Nelson, et al.	
	A181	6,173,399		1/9/2001	Gilbrech	
	A182	6,185,203		2/6/2001	Berman	
	A183	6,202,153		3/13/2001	Diamant, et al.	
	A184	6,209,023		3/27/2001	Dimitroff, et al.	
	A185	6,219,771		4/17/2001	Kikuchi, et al.	
	A186	6,223,266		4/24/2001	Sartore	
	A187	6,230,218		5/8/2001	Casper, et al.	
	A188	6,243,827		6/5/2001	Renner, Jr.	
					Date Considered	

INFORMATION DISCLOSURE STATEMENT BY APPLICANT				Application Number	12/690,592	
				Filing Date	01/20/2010	
				First Named Inventor	Geoffrey B. Hoese	
				Group Art Unit	2111	
				Examiner Name	Unknown	
Sheet	7	of	9	Attorney Docket Number	CROSS1120-33	
U.S. PATENT DOCUMENTS						
Examiner Initials	Cite No.	Document Number		Publication Date MM-DD-YYYY	Name of Patentee or Applicant of Cited Document	Pages, Columns, Lines Where Relevant Passages or Figures Appear
		Number-Kind Code (if known)				
	A189	6,260,120		7/10/2001	Blumenau, et al.	
	A190	6,268,789		7/31/2001	Diamant, et al.	
	A191	6,308,247		10/23/2001	Ackerman	
	A192	6,330,629		12/11/2001	Kondo, et al.	
	A193	6,330,687		12/11/2001	Griffith	
	A194	6,341,315		1/22/2002	Arroyo, et al.	
	A195	6,343,324		1/29/2002	Hubis, et al.	
	A196	6,363,462		3/26/2002	Bergsten	
	A197	6,401,170		6/4/2002	Griffith, et al.	
	A198	6,421,753		7/16/2002	Hoese, et al.	
	A199	6,425,035		7/23/2002	Hoese, et al.	
	A200	6,425,036		7/23/2002	Hoese, et al.	
	A201	6,425,052		6/23/2002	Hashemi	
	A202	6,453,345		9/17/2002	Trcka, et al.	
	A203	6,484,245		11/19/2002	Sanada, et al.	
	A204	6,529,996		3/4/2003	Nguyen, et al.	
	A205	6,547,576		4/15/2003	Peng, et al.	
	A206	6,560,750		5/6/2003	Chien, et al.	
	A207	6,563,701		5/13/2003	Peng, et al.	
	A208	6,775,693		8/10/2004	Adams	
	A209	6,792,602		9/14/2004	Lin, et al.	
	A210	6,820,212		11/16/2004	Duchesne, et al.	
	A211	6,854,027		2/8/2005	Hsu, et al.	
	A212	6,862,637		3/1/2005	Stupar	
	A213	6,874,043		3/29/2005	Treggiden	
	A214	6,874,100		3/29/2005	Rauscher	
	A215	6,910,083		6/21/2005	Hsu, et al.	
	A216	7,065,076		6/20/2006	Nemazie	
	A217	7,127,668		10/24/2006	McBryde, et al.	
	A218	7,133,965		11/7/2006	Chien	
Examiner Signature				Date Considered		

INFORMATION DISCLOSURE STATEMENT BY APPLICANT				Application Number	12/690,592	
				Filing Date	01/20/2010	
				First Named Inventor	Geoffrey B. Hoese	
				Group Art Unit	2111	
				Examiner Name	Unknown	
Sheet	8	of	8	Attorney Docket Number	CROSS1120-33	
U.S. PATENT DOCUMENTS						
Examiner Initials	Cite No.	Document Number		Publication Date MM-DD-YYYY	Name of Patentee or Applicant of Cited Document	Pages, Columns, Lines Where Relevant Passages or Figures Appear
		Number-Kind Code (if known)				
	A219	7,188,111		3/6/2007	Chen, et al.	
	A220	7,216,225		5/8/2007	Haviv, et al.	
	A221	7,251,248		7/31/2007	Trossell, et al.	
	A222	7,281,072		10/9/2007	Liu, et al.	
	A223	D470,486		2/18/2003	Cheng	
	A224	2002/0083221		6/27/2002	Tsai, et al.	
	A225	2006/0277326		12/7/2006	Tsai, et al.	
	A226	2006/0294416		12/28/2006	Tsai, et al.	
	A227	2006/0218322		09/2006	Hoese, et al.	
FOREIGN PATENT DOCUMENTS						
Examiner Initials	Cite No.	Foreign Patent Document		Publication Date MM-DD-YYYY (Number 43)	Name of Patentee or Applicant of Cited Document	Pages, Columns, Lines Where Relevant Passages or Figures Appear
		Country Code-Number-Kind Code (if known)				
	B1	GB 2296798 A		7/10/1996	Spring Consultants Limited	
	B2	GB 2297636 A		8/7/1996	Spring Consultants Limited	
	B3	JP 8-230895		9/10/1996	Kikuchi, et al.	
	B4	EP 0810530 A2		12/3/1997	Sun Microsystems, Inc.	
	B5	EP 0827059 A2		3/4/1998	NEC Corporation	
	B6	WO 99/34297 A1		7/8/1999	Crossroads Systems, Inc.	
Examiner Signature					Date Considered	

INFORMATION DISCLOSURE STATEMENT BY APPLICANT				Application Number	12/690,592
				Filing Date	01/20/2010
				First Named Inventor	Geoffrey B. Hoes
				Group Art Unit	2111
				Examiner Name	Unknown
Sheet	9	of	9	Attorney Docket Number	CROSS1120-33
U.S. PATENT DOCUMENTS					
Examiner Initials	Cite No.	Document Number Number-Kind Code (if known)	Publication Date MM-DD-YYYY	Name of Patentee or Applicant of Cited Document	Pages, Columns, Lines Where Relevant Passages or Figures Appear
FOREIGN PATENT DOCUMENTS					
Examiner Initials	Cite No.	Foreign Patent Document Country Code-Number-Kind Code (if known)	Publication Date MM-DD-YYYY (Number 43)	Name of Patentee or Applicant of Cited Document	Pages, Columns, Lines Where Relevant Passages or Figures Appear
	B7	GB 2341715	03/22/2000	SpringTek Limited	
	B8	JP 6301607	10/28/1994	Hitachi Ltd.	
	B9	WO 98/36357	08/20/1998	Transwitch Corporation	
	B10	WO 91/03788	3/21/1991	Auspex Systems, Inc.	
	B11	WO 1997033227	8/4/1998	Nippon Telegraph & AMP; Telephone Corp.	
	B12	AU 647414	3/24/1994	Auspex Systems, Inc.	
	B13	AU 670376	7/11/1996	Auspex Systems, Inc.	
	B14	CA 2066443	10/21/2003	Auspex Systems, Inc.	
	B15	EP 0490973	2/25/1998	Auspex Systems, Inc.	
	B16	IL 095447	5/30/1994	Auspex Systems, Inc.	
	B17	IL 107645	9/12/1996	Auspex Systems, Inc.	
	B18	JP 10097493	4/14/1998	Sun Microsyst. Inc.	
	B19	JP 1997251437	9/22/1997	Toshiba Corporation	
	B20	JP 1993181609	7/23/1993	NEC Corp.	
	B21	JP 1997185594	7/15/1997	Tandem Computers, Inc.	
	B22	JP 1995020994	1/24/1995	Hitachi, Ltd.	
	B23	JP 5502525	4/28/1993	Auspex Systems, Inc.	
	B24	JP 5181609	7/23/1993	Nippon Electric Co.	
	B25	JP 720994	1/24/1995	Hitachi Seisakusho Co., Ltd.	
Examiner Signature				Date Considered	

INFORMATION DISCLOSURE STATEMENT				Application Number		12/690,592
				Filing Date		01/20/2010
				First Named Inventor		Geoffrey B. Hoese
				Group Art Unit		2111
				Examiner Name		Unknown
Sheet	1	of	9	Atty Docket Number		CROSS1120-33
Examiner Initials	Cite No.	OTHER PRIOR ART -- NON PATENT LITERATURE DOCUMENTS				Date
	C4	Black Box, SCSI Fiberoptic Extender, Single-Ended, Product Insert, 2 pages, 1996				6/18/1905
	C5	Block-Based Distributed File Systems, Anthony J. McGregor, July 1997				
	C6	Compaq StorageWorks HSG80 Array Controller ACS Version 8.3 (Maintenance and Service Guide) 11/98				
	C7	Compaq StorageWorks HSG80 Array Controller ACS Version 8.3 (Configuration and CLI Reference Guide) 11/98				
	C8	CRD-5500, RAID DISK ARRAY CONTROLLER Product Insert, pp. 1-5				
	C9	CRD-5500, SCSI RAID CONTROLLER OEM Manual, Rev. 1.3, February 26, 1996, pp. 1-54				2/26/1996
	C10	CRD-5500, SCSI RAID CONTROLLER Users Manual, Rev. 1.3, November 21, 1996, pp. 10-92				11/21/1996
	C11	DIGITAL StorageWorks HSZ70 Array Controller HSOF Version 7.0 EK-SHZ70-RM.A01 CLI Reference Manual.				7/1/1997
	C12	DIGITAL Storage Works, HSZ70 Array Controller, HSOF Version 7.0 EK-HSZ70-CG. A01, Digital Equipment Corporation, Maynard, Massachusetts				7/1/1997
	C13	DIGITAL StorageWorks, Using Your HSZ70 Array Controller in a SCSI Controller Shelf (DS-BA356-M Series), User's Guide, pp. 1-1 through A-5 with index, January 1998.				1/1/1998
	C14	DIGITAL StorageWorks HSZ70 Array Controller HSOF Version 7.0 EK-HSZ70-SV. A01				1997-
	C15	DIGITAL StorageWorks HSG80 Array Controller ACS Version 8.0 (User's Guide 1/98				
	C16	DP5380 Asynchronous SCSI Interface, National Semiconductor Corporation, Arlington, TX, May 1989, pp. 1-32				
	C17	Emerson, "Encor Communications: Performance evaluation of switched fibre channel I/O system using--FCP for SCSI" February 1995, IEEE, pp. 479-484				2/1/1995
	C18	Fiber channel (FCS)/ATM internetworking: a design solution				
	C19	Fiber Channel storage interface for video-on-demand servers by Anazaloni, et al.				6/15/1905
	C20	Fibre Channel and ATM: The Physical Layers, Jerry Quam WESCON/94, published 27-29 September 1994. Pages 648-652.				
	C21	Gen5 S-Series XL System Guide Revision 1.01 by Chen				6/18/1905
	C22	Graphical User Interface for MAXSTRAT Gen5/Gen-S Servers User's guide 1.1				6/11/1996
	C23	High Performance Data transfers Using Network-Attached Peripherals at the national Storage Laboratory by Hyer				2/26/1993
Examiner Signature					Date Considered	

INFORMATION DISCLOSURE STATEMENT				Application Number		12/690,592
				Filing Date		01/20/2010
				First Named Inventor		Geoffrey B. Hoese
				Group Art Unit		2111
				Examiner Name		Unknown
Sheet	2	of	9	Atty Docket Number		CROSS1120-33
Examiner Initials	Cite No.	OTHER PRIOR ART -- NON PATENT LITERATURE DOCUMENTS				Date
	C24	IFT-3000 SCSI to SCSI Disk array Controller Instruction Manual Revision 2.0 by Infotrend Technologies, Inc.				1995-
	C25	Implementing a Fibre Channel SCSI transport by Snively				1994-
	C26	"InfoServer 150--Installation and Owner's Guide", EK-INFSV-OM-001, Digital Equipment Corporation, Maynard, Massachusetts 1991, Chapters 1 and 2				
	C27	InfoServer 150VXT Photograph				
	C28	IBM Technical Publication: Guide to Sharing and Partitioning IBM Tape Library Dataservers, November 1996, pp. 1-256				11/1/1996
	C29	IBM Technical Publication: Magstar and IBM 3590 High Performance Tape Subsystem Technical Guide, November 1996, pp. 1-269				11/1/1996
	C30	Misc. Reference Manual Pages, SunOS 5.09				
	C31	InfoServer 100 System Operations Guide, First Edition Digital Equipment Corporation, 1990				
	C32	Johnson, D.B., et al., "The Peregrine High Performance RPC System", Software-Practice and Experience, 23(2):201-221, Feb. 1993				
	C33	Local-Area networks for the IBM PC by Haugdahl				
	C34	New serial I/Os speed storage subsystems by Bursky				2/6/1995
	C35	Petal: Distributed Virtual Disks, Edward K. Lee and Chandramohan A. Thekkath, ACM SIGPLAN Notices, Volume 31, Issue 9, September 1996, pages 84-92.				
	C36	Pictures of internal components of the InfoServer 150, taken from http://bindarydinosaurs.couk/Museum/Digital/infoServer/infoServer.php in Nov. 2004.				
	C37	Raidtec FibreArray and Raidtec FlexArray UltraRAID Systems", Windows IT PRO Article, October 1997				
	C38	S.P. Joshi, "Ethernet controller chip interfaces with variety of 16-bit processors," electronic Design, Hayden Publishing Co., Inc., Rochelle Park, NJ, October 14, 1982. pp 193-200				
	C39	Simplest Migration to Fibre Channel Technology" Article, Digital Equipment Corporation, November 10, 1997, published on PR Newswire				11/10/1997
	C40	Systems Architectures Using Fibre Channel, Roger Cummings, Twelfth IEEE Symposium on Mass Storage Systems, Copyright 1993 IEEE. Pages 251-256				
	C41	Office Action dated 01/21/03 for 10/174,720 (CROSS1120-8)				1/21/2003
	C42	Office Action dated 02/27/01 for 09/354,682 (CROSS1120-1)				2/27/2001
	C43	Office Action dated 08/11/00 for 09/354,682 (CROSS1120-1)				8/11/2000
	C44	Office Action dated 12/16/99 for 09/354,682 (CROSS1120-1)				12/16/1999
	C45	Office Action dated 11/06/02 for 10/023,786 (CROSS1120-4)				11/6/2002
	C46	Office Action dated 01/21/03 for 10/081,110 (CROSS1120-5)				1/21/2003
Examiner Signature					Date Considered	

INFORMATION DISCLOSURE STATEMENT				Application Number	12/690,592
				Filing Date	01/20/2010
				First Named Inventor	Geoffrey B. Hoese
				Group Art Unit	2111
				Examiner Name	Unknown
Sheet	3	of	9	Atty Docket Number	CROSS1120-33
Examiner Initials	Cite No.	OTHER PRIOR ART -- NON PATENT LITERATURE DOCUMENTS			Date
	C47	Office Action in Ex Parte Reexamination 90/007,127, mailed February 7, 2005.			2/7/2005
	C48	Office Action in Ex Parte Reexamination 90/007,125, mailed February 7, 2005.			2/7/2005
	C49	Office Action in Ex Parte Reexamination 90/007,126, mailed February 7, 2005.			2/7/2005
	C50	Office Action in Ex Parte Reexamination 90/007,124, mailed February 7, 2005.			2/7/2005
	C51	Office Action in Ex Parte Reexamination 90/007,123, mailed February 7, 2005.			2/7/2005
	C52	European Office Action issued April 1, 2004 in Application No. 98966104.6-2413			4/1/2004
	C53	Office Action dated 1/27/2005 in 10/658,163 (CROSS1120-13)			1/27/2005
	C54	DIGITAL "System Support Addendum", SSA 40.78.01-A, AE-PNZJB-TE, pgs 1-3			4/1/1993
	C55	DIGITAL "Software Product Description", SSA 40.78.01, AE-PNZJB-TE, pgs 1-3			4/1/1993
	C56	DIGITAL EQUIPMENT CORPORATION, "InfoServer 100 Installation and Owner's Guide", Order Number EK-DIS1K-IN-001, First Edition			10/1/1990
	C57	DIGITAL EQUIPMENT CORPORATION, "InfoServer 100 System Operation Guide", Order Number EK-DIS1K-UG-001, First Edition, pgs i-Index 5			10/1/1990
	C58	ELLIOTT, "Working Draft American National Standard, Project T10/1562-D, Revision 5, pgs. i-432			7/9/2003
	C59	SATRAN, "Standards-Track," May 2001, iSCSI, pgs. 9-87			11/1/2000
	C60	SATRAN, et al. "IPS Internet Draft, iSCSI, pgs 1-8			11/1/2000
	C61	APT TECHNOLOGIES, INC., "Serial ATA: High Speed Serialized AT Attachment", Rev. 1.0a, pgs. 1-310			1/7/2003
	C63	Defendant's First Supplemental Trial Exhibit List, Crossroads Systems, Inc., v. Chaparral Network Storage, Inc., C.A. No. A-00CA-217-SS (W.D. Tex. 2001). (CD-Rom)			
	C64	Defendant's Third Supplemental Trial Exhibit List, Crossroads Systems, Inc. v. Pathlight Technology, Inc., C.A. No. A-00CA-248-SS (W.D. Tex. 2001) (CD-Rom)			
	C65	Plaintiff's Fourth Amended Trail Exhibit List, Crossroads Systems, Inc. v. Chaparral Network Storage, Inc, C.A. No. A-00CA-217-SS (W.D. Tex. 2001) (CD-Rom)			
	C66	Plaintiff's Revised Trial Exhibit List, Crossroads Systems, Inc. v. Pathlight Technology, Inc., C.A. No. A-00CA-248-SS (W.D. Tex. 2001). (CD-Rom)			
	C67	Trail Transcripts, Crossroads Systems, Inc. v. Chaparral Network Storage, Inc., C.A. No. A-00CA-217-SS (W.D. Tex. 2001) Day 1 -5 (CD-Rom)			
	C68	Trail Transcripts, Crossroads Systems, Inc. v. Pathlight Technology, Inc., C.A. No. A-00CA-248-SS (W.D. Tex. 2001). Day 1-4 (CD-Rom)			
Examiner Signature				Date Considered	

INFORMATION DISCLOSURE STATEMENT				Application Number	12/690,592
				Filing Date	01/20/2010
				First Named Inventor	Geoffrey B. Hoese
				Group Art Unit	2111
				Examiner Name	Unknown
Sheet	4	of	9	Atty Docket Number	CROSS1120-33
Examiner Initials	Cite No.	OTHER PRIOR ART -- NON PATENT LITERATURE DOCUMENTS			Date
	C72	Datasheet for CrossPoint 4100 Fibre Channel to SCSI Router (Dedek Ex 41 (ANCT 117-120)) (CD-ROM Chaparral Exhibits D012)			
	C73	Symbios Logic- Software Interface Specification Series 3 SCSI RAID Controller Software Release 02.xx (Engelbrecht Ex 2 (LSI 1421-1658)) (CD-ROM Chaparral Exhibits D013)			12/3/1997
	C74	Press Release- Symbios Logic to Demonstrate Strong Support for Fibre Channel at Fall Comdex (Engelbrecht 12 (LSI 2785-86)) (CD-ROM Chaparral Exhibits D016)			11/13/1996
	C75	OEM Datasheet on the 3701 Controller (Engelbrecht 13 (LSI 01837-38)) (CD-ROM Chaparral Exhibits D017)			6/17/1905
	C76	Nondisclosure Agreement Between Adaptec and Crossroads Dated 10/17/96 (Quisenberry Ex 25 (CRDS 8196)) (CD-ROM Chaparral Exhibits D020)			10/17/1996
	C77	Organizational Presentation on the External Storage Group (Lavan Ex 1 (CNS 182242-255)) (CD-ROM Chaparral Exhibits D021)			4/11/1996
	C78	Bridge Phase II Architecture Presentation (Lavan Ex 2 (CNS 182287-295)) (CD-ROM Chaparral Exhibits D022)			4/12/1996
	C79	Bridge. C, Bridge Between SCSI-2 and SCSI-3 FCP (Fibre Channel Protocol) (CD-ROM Chaparral Exhibits P214)			
	C80	Attendees/Action Items from 4/12/96 Meeting at BTC (Lavan Ex 3 (CNS 182241)) (CD-ROM Chaparral Exhibits D023)			4/12/1996
	C81	Brooklyn Hardware Engineering Requirements Documents, Revision 1.4 (Lavan Ex 4 (CNS 178188-211)) (CD-ROM Chaparral Exhibits D024) by Pecone			5/26/1996
	C82	Brooklyn Single-Ended SCSI RAID Bridge Controller Hardware OEM Manual, Revision 2.1 (Lavan EX 5 (CNS 177169-191)) (CD-ROM Chaparral Exhibits D025)			3/2/1996
	C83	Coronado Hardware Engineering Requirements Document, Revision 0.0 (Lavan Ex 7 (CNS 176917-932)) (CD-ROM Chaparral Exhibits D027) by O'Dell			9/30/1996
	C84	ESS/FPG Organization (Lavan Ex 8 (CNS 178639-652)) (CD-ROM Chaparral Exhibits D028)			12/6/1996
	C85	Adaptec MCS ESS Presents: Intelligent External I/O Raid Controllers "Bridge" Strategy (Lavan Ex 9 (CNS 178606-638)). (CD-ROM Chaparral Exhibits D029)			2/6/1996
	C86	AEC-7313 Fibre Channel Daughter Board (for Brooklyn) Engineering Specification, Revision 1.0 (Lavan Ex 10 (CNS 176830-850)) (CD-ROM Chaparral Exhibits D030)			2/27/1997
	C87	Bill of Material (Lavan Ex 14 (CNS 177211-214)) (CD-ROM Chaparral Exhibits D034)			7/24/1997
	C88	AEC-. 4412B, AEC-7412/B2 External RAID Controller Hardware OEM Manual, Revision 2.0 (Lavan Ex 15 (CNS 177082-123)) (CD-ROM Chaparral Exhibits D035)			6/27/1997
Examiner Signature					Date Considered

INFORMATION DISCLOSURE STATEMENT				Application Number	12/690,592
				Filing Date	01/20/2010
				First Named Inventor	Geoffrey B. Hoese
				Group Art Unit	2111
				Examiner Name	Unknown
Sheet	5	of	9	Atty Docket Number	CROSS1120-33
Examiner Initials	Cite No.	OTHER PRIOR ART -- NON PATENT LITERATURE DOCUMENTS			Date
	C89	Coronado II, AEC-7312A Fibre Channel Daughter (for Brooklyn) Hardware Specification, Revision 1.2 (Lavan Ex 16 (CNS 177192-210)) (CD-ROM Chaparral Exhibits D036) by Tom Yang			7/18/1997
	C90	AEC-4412B, AEC7412/3B External RAID Controller Hardware OEM Manual, Revision 3.0. (Lavan Ex 17 (CNS 177124-165)) (CD-ROM Chaparral Exhibits D037)			8/25/1997
	C91	Memo Dated 8/15/97 to AEC-7312A Evaluation Unit Customers re: B001 Release Notes (Lavan Ex 18 (CNS 182878-879)) (CD-ROM Chaparral Exhibits D038)			8/15/1997
	C92	Brooklyn Main Board (AES-0302) MES Schedule (Lavan Ex 19 (CNS 177759-763)) (CD-ROM Chaparral Exhibits D039)			2/11/1997
	C93	News Release-Adaptec Adds Fibre Channel Option to its External RAID Controller Family (Lavan Ex 20 (CNS 182932-934)) (CD-ROM Chaparral Exhibits D040)			5/6/1997
	C94	AEC-4412B/7412B User's Guide, Rev. A (Lavan Ex 21) (CD-ROM Chaparral Exhibits D041)			6/19/1905
	C95	Data Book- AIC-7895 PCI Bus Master Single Chip SCSI Host Adapter (Davies Ex 1 (CNS 182944-64)) (CD-ROM Chaparral Exhibits D046)			5/21/1996
	C96	Data Book- AIC-1160 Fibre Channel Host Adapter ASIC (Davies Ex 2 (CNS 181800-825)) (CD-ROM Chaparral Exhibits D047)			6/18/1905
	C97	Viking RAID Software (Davies Ex 3 (CNS 180969-181026)) (CD-ROM Chaparral Exhibits D048)			6/18/1905
	C98	Header File with Structure Definitions (Davies Ex 4 (CNS 180009-018)) (CD-ROM Chaparral Exhibits D049)			8/8/1996
	C99	C++ SourceCode for the SCSI Command Handler (Davies Ex 5 (CNS 179136-168)) (CD-ROM Chaparral Exhibits D050)			8/8/1996
	C100	Header File Data Structure (Davies Ex 6 (CNS 179997-180008)) (CD-ROM Chaparral Exhibits D051)			1/2/1997
	C101	SCSI Command Handler (Davies Ex 7 (CNS 179676-719)) (CD-ROM Chaparral Exhibits D052)			1/2/1997
	C102	Coronado: Fibre Channel to SCSI Intelligent RAID Controller Product Brief (Kalwitz Ex 1 (CNS 182804-805)) (CD-ROM Chaparral Exhibits D053)			
	C103	Bill of Material (Kalwitz Ex 2 (CNS 181632-633)) (CD-ROM Chaparral Exhibits D054)			3/17/1997
	C104	Emails Dated 1/13-3/31/97 from P. Collins to Mo re: Status Reports (Kalwitz Ex 3 (CNS 182501-511)) (CD-ROM Chaparral Exhibits D055)			
	C105	Hardware Schematics for the Fibre Channel Daughtercard Coronado (Kalwitz Ex 4 (CNS 181639-648)) (CD-ROM Chaparral Exhibits D056)			
Examiner Signature				Date Considered	

INFORMATION DISCLOSURE STATEMENT				Application Number	12/690,592
				Filing Date	01/20/2010
				First Named Inventor	Geoffrey B. Hoese
				Group Art Unit	2111
				Examiner Name	Unknown
Sheet	6	of	9	Atty Docket Number	CROSS1120-33
Examiner Initials	Cite No.	OTHER PRIOR ART -- NON PATENT LITERATURE DOCUMENTS			Date
	C106	Adaptec Schematics re AAC-340 (Kalwitz Ex 14 CNS 177215-251)) (CD-ROM Chaparral Exhibits D057)			
	C107	Bridge Product Line Review (Manzanares Ex 3 (CNS 177307-336)) (CD-ROM Chaparral Exhibits D058)			
	C108	AEC Bridge Series Products-Adaptec External Controller RAID Products Pre-Release Draft, v.6 (Manzanares Ex 4 (CNS 174632-653)). (CD-ROM Chaparral Exhibits D059)			10/28/1997
	C109	Hewlett-Packard Roseville Site Property Pass for Brian Smith (Dunning Ex 14 (HP 489) (CD-ROM Chaparral Exhibits D078)			11/7/1996
	C110	Distribution Agreement Between Hewlett-Packard and Crossroads (Dunning Ex 15 (HP 326-33) (CD-ROM Chaparral Exhibits D079)			
	C111	HPFC-5000 Tachyon User's Manuel, First Edition (PTI 172419-839) (CD-ROM Chaparral Exhibits D084)			5/1/1996
	C112	X3T10 994D - (Draft) Information Technology: SCSI-3 Architecture Model, Rev. 1.8 (PTI 165977) (CD-ROM Chaparral Exhibits D087)			
	C113	X3T10 Project 1047D: Information Technology- SCSI-3 Controller Commands (SCC), Rev, 6c (PTI 166400-546) (CD-ROM Chaparral Exhibits D088)			9/3/1996
	C114	X3T10 995D- (Draft) SCSI-3 Primary Commands, Rev. 11 (Wanamaker Ex 5 (PTI 166050-229)) (CD-ROM Chaparral Exhibits D089)			11/13/1996
	C115	VBAR Volume Backup and Restore (CRDS 12200-202) (CD-ROM Chaparral Exhibits D099)			
	C116	Preliminary Product Literature for Infinity Commstor's Fibre Channel to SCSI Protocol Bridge (Smith Ex 11; Quisenberry Ex 31 (SPLO 428-30) (CD-ROM Chaparral Exhibits D143)			8/19/1996
	C117	Letter dated 7/12/96 from J. Boykin to B. Smith re: Purchase Order for Evaluation Units from Crossroads (Smith Ex 24) CRDS 8556-57) (CD-ROM Chaparral Exhibits D144)			7/12/1996
	C118	CrossPoint 4100 Fibre Channel to SCSI Router Preliminary Datasheet (Hulsey Ex 9 (CRDS 16129-130)) (CD-ROM Chaparral Exhibits D145)			11/1/1996
	C119	CrossPoint 4400 Fibre Channel to SCSI Router Preliminary Datasheet (Bardach Ex. 9, Quisenberry Ex 33 (CRDS 25606-607)) (CD-ROM Chaparral Exhibits D153)			11/1/1996
	C120	Fax Dated 07/22/96 from L. Petti to B. Smith re: Purchase Order from Data General for FC2S Fibre to Channel SCSI Protocol Bridge Model 11 (Smith Ex 25; Quisenberry Ex 23; Bardach Ex 11 (CRDS 8552-55; 8558) (CD-ROM Chaparral Exhibits D155)			7/22/1996
	C121	Email Dated 12/20/96 from J. Boykin to B. Smith re: Purchase Order for Betas in February and March (Hoese Ex 16, Quisenberry Ex 25; Bardach Ex 12 (CRDS 13644-650) (CD-ROM Chaparral Exhibits D156)			12/20/1996
	C122	Infinity Commstor Fibre Channel Demo for Fall Comdex, 1996 (Hoese Ex 15, Bardach Ex 13 (CRDS 27415) (CD-ROM Chaparral Exhibits D157)			
Examiner Signature				Date Considered	

INFORMATION DISCLOSURE STATEMENT				Application Number	12/690,592
				Filing Date	01/20/2010
				First Named Inventor	Geoffrey B. Hoese
				Group Art Unit	2111
				Examiner Name	Unknown
Sheet	7	of	9	Atty Docket Number	CROSS1120-33
Examiner Initials	Cite No.	OTHER PRIOR ART -- NON PATENT LITERATURE DOCUMENTS			Date
	C123	Fax Dated 12/19/96 from B. Bardach to T. Rarich re: Purchase Order Information (Bardach Ex. 14; Smith Ex 16 (CRDS 4460)) (CD-ROM Chaparral Exhibits D158)			12/19/1996
	C124	Miscellaneous Documents Regarding Comdex (Quisenberry Ex 2 (CRDS 27415-465)) (CD-ROM Chaparral Exhibits D165)			
	C125	CrossPoint 4100 Fibre Channel to SCSI Router Preliminary Datasheet (Quisenberry) Ex 3 (CRDS 4933-34) (CD-ROM Chaparral Exhibits D166) (CD-ROM Chaparral Exhibits D166)			
	C126	CrossPoint 4400 Fibre to Channel to SCSI Router Preliminary Datasheet; Crossroads Company and Product Overview (Quisenberry Ex 4 (CRDS 25606; 16136)) (CD-ROM Chaparral Exhibits D167)			
	C127	Crossroads Purchase Order Log (Quisenberry Ex 9 (CRDS 14061-062)) (CD-ROM Chaparral Exhibits D172)			
	C128	RAID Manager 5 with RDAC 5 for UNIX V.4 User's Guide (LSI-01854) (CD-ROM Chaparral Exhibits P062)			9/1/1996
	C129	Letter dated May 12, 1997 from Alan G. Leal to Barbara Bardach enclosing the original OEM License and Purchase Agreement between Hewlett-Package Company and Crossroads Systems, Inc. (CRDS 02057) (CD-ROM Chaparral Exhibits P130)			
	C130	CR4x00 Product Specification (CRDS 43929) (CD-ROM Chaparral Exhibits P267)			6/1/1998
	C131	Symbios Logic – Hardware Functional Specification for the Symbios Logic Series 3 Fibre Channel Disk Array Controller Model 3701 (Engelbrecht Ex 3 (LSI-1659-1733) (CD-ROM Pathlight Exhibits D074)			
	C132	Report of the Working Group on Storage I/O for Large Scale Computing; Department of Computer Science Duke University: CS-1996-21 (PTI 173330-347). (CD-ROM Pathlight Exhibits D098)			
	C133	Brian Allison's 1999 Third Quarter Sales Plan (PDX 38)CNS 022120-132) (CD-ROM Pathlight Exhibits D201)			6/5/2001
	C134	Brooklyn SCSI-SCSI Intelligent External RAID Bridge Definition Phase External Documentation ((CD-ROM Pathlight Exhibits D129)			
	C135	StorageWorks HSx70 System Specification by Steve Sicola dated 6/11/96 4:57pm, Revision 4.			6/11/1996
	C136	ANSI TR X3.xxx-199x, Revision 9 of X3-991D. Draft Proposed X3 Technical Report - Small Computer System Interface - 3 Generic Packetized Protocol (SCSI-GPP). Computer and Business Equipment Manufacturers Assoc.			
	C137	Enterprise Systems Connection (ESON) Implementation Guide, July 1996, IBM International Technical Support Organization, Poughkeepsie Center			7/1/1996
Examiner Signature				Date Considered	

INFORMATION DISCLOSURE STATEMENT				Application Number		12/690,592	
				Filing Date		01/20/2010	
				First Named Inventor		Geoffrey B. Hoese	
				Group Art Unit		2111	
				Examiner Name		Unknown	
Sheet	8	of	9	Atty Docket Number		CROSS1120-33	
Examiner Initials	Cite No.	OTHER PRIOR ART -- NON PATENT LITERATURE DOCUMENTS				Date	
	C138	Digital Delivers Industry-Leading Enterprise-Class Storage Solutions. StorageWorks Family Provides Easiest Path to Fibre Channel. Three pages by Company News Oncall dated 09/09/04				9/9/2004	
	C139	American National Standard for Information Technology – Fibre Channel Protocol for SCSI. ANSI X3.269-1996				6/18/1905	
	C140	F1710A File Control Unit and F6493 Array Disk Subsystem by Hitoshi Matsushima, Shojiro Okada and Tetsuro Kudo.				2/3/1995	
	C141	The Legend of AMDAHL by Jeffrey L. Rodengen (5 pages)					
	C142	Office Action dated February 6, 2007 from the Japanese Patent Office regarding related application No. 526873/2000.				2/6/2007	
	C143	InfoServer 100 System Operation Guide, Order Number EK-DIS1K-UG-001					
	C144	iNFOsERVER 100 Installation and Owner's Guide, Order Number EK-DIS1K-IN-001					
	C145	Software Product Description: Product Name: InfoServer 100 Software, Version 1.1 SPD 38.59.00				11/1/1991	
	C146	Software Product Description: Product Name: InfoServer Client for ULTRIX, Version 1.1, SPD 40.78.01				4/1/1993	
	C147	Draft Proposed American National Standard. X3.269-199X, Revision 012. Information System - dpANS Fibre Channel Protocol fo SCSI.				12/4/1995	
	C148	Impactdata Launches Breakthrough Architecture for Network Storage.				11/13/1996	
	C149	Impactdata..News Release: Impactdata Introduces New Storage Architecture for High Performance Computing. 2 Pages.				11/12/1996	
	C150	Impactdata..News Release: Impactdata's Network Peripheral Adapter (NPA) Pushes Technology Envelope of Data Storage Management in High-Speed Computing Environments. 2 Pages.				11/12/1996	
	C151	Impactdata..News Release: Impactdata and Storage Concepts Announce Integration of FibreRAID II Storage Solution with Impactdata's Distributed Storage Node Architecture (DSNA). 2 pages.				11/18/1996	
	C152	Impactdata..News Release: Breece Hill Libraries Now Able to Attach Directly to High Speed Networks Peripheral Adapter from Impactdata. 2 Pages.				11/20/1996	
	C153	Impactdata - DSNA Questions and Answers. 22 Pages.					
	C154	Impactdata - Network Storage Solutions. 4 pages.					
	C155	Network Storage Building Blocks. 2 Pages.					
	C156	Impactdata - NPA (Network Peripheral Interface). 4 Pages					
	C157	Impactdata - CPI (Common Peripheral Interfae). 2 Pages					
	C158	Impactdata - SNC (Storage Node Controller). 2 Pages					
	C159	Impactdata - DSNA (Distributed Storage Node Architecture) Protocol. 2 Pages					
	C160	Impactdata - DS-50. 2 Pages					
	C161	Impactdata - Corporate Fact Sheet. 1 Page					
Examiner Signature						Date Considered	

INFORMATION DISCLOSURE STATEMENT				Application Number	12/690,592
				Filing Date	01/20/2010
				First Named Inventor	Geoffrey B. Hoesse
				Group Art Unit	2111
				Examiner Name	Unknown
Sheet	9	of	9	Atty Docket Number	CROSS1120-33
Examiner Initials	Cite No.	OTHER PRIOR ART -- NON PATENT LITERATURE DOCUMENTS			Date
	C162	Raider-5 "Disk Array Manual for the UltraSCSI Controller". Part No. 261-0013-002. 191 Pages			
	C163	Impactdata - White Paper: Distributed Storage Node Architecture (DSNA). January, 1997			01/97
	C164	Impactdata - DSNA Distributed Storage Node Architecture "Reference Guide". 44 Pages			
	C165	F1710 Logic Specification			
	C166	Translation of Final Office Action issued in JP 526873/2000 mailed 05/14/08. 4 Pages.			5/14/2008
	C167	Office Action issued in USPA 11/851,837 dated 12/22/08, Hoesse, 7 pages			12/22/2008
	C168	English Translation of Japanese Laid-Open Publication No. 5-181609. 9 pgs.			7/23/1993
	C169	English Translation of Japanese Laid-Open Publication No. 7-20994. 57 pgs			1/24/1995
	C170	F1710 File Control Unit (FCU) Logical Specifications. 11 Pages			12/9/1997
Examiner Signature				Date Considered	

RSJ

(12) UK Patent Application (19) GB (11) 2 296 798 (13) A

(43) Date of A Publication 10.07.1998

<p>(21) Application No 9500173.1</p> <p>(22) Date of Filing 05.01.1995</p>	<p>(51) INT CL⁶ G06F 12/02</p> <p>(52) UK CL (Edition O) G4A AMX</p>
<p>(71) Applicant(s) Spring Consultants Limited (Incorporated in the United Kingdom) Unit 5, Ashbrook Mews, Westbrook Street, BLEWBURY, Oxon, OX11 9QA, United Kingdom</p>	<p>(56) Documents Cited None</p> <p>(58) Field of Search UK CL (Edition N) G4A AMX INT CL⁶ G06F 12/02 ONLINE DATABASES : WPI, INSPEC</p>
<p>(72) Inventor(s) Andrew Paul George Randall Norman Hamilton Burkies</p>	
<p>(74) Agent and/or Address for Service Atkinson & Co Sixth Floor, High Holborn House, 52-54 High Holborn, LONDON, WC1V 6SE, United Kingdom</p>	

(54) Storing data efficiently on a RAID

(57) Data is stored in such a way that a plurality of user terminals 16 are given access to a large storage volume in the form of a redundant array of inexpensive drives (RAID 5) 21 to 25. The large storage volume is divided into a plurality of storage blocks and each of said blocks has a capacity which is smaller than the size of an emulated logical disc drive. In operation, physical blocks of data are mapped onto an emulated drive as storage is required up to a predetermined capacity.

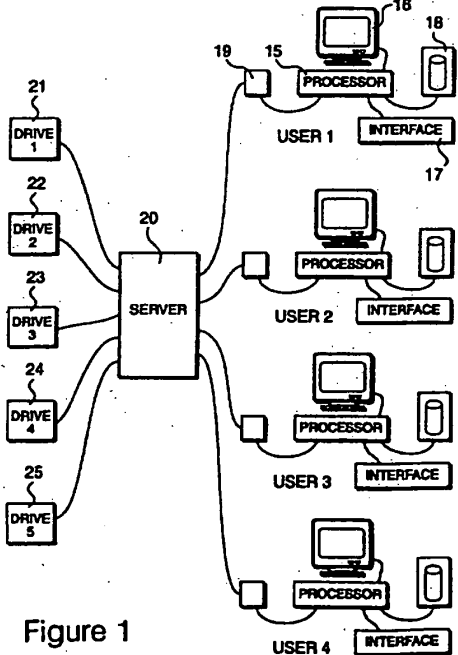

Figure 1

GB 2 296 798 A

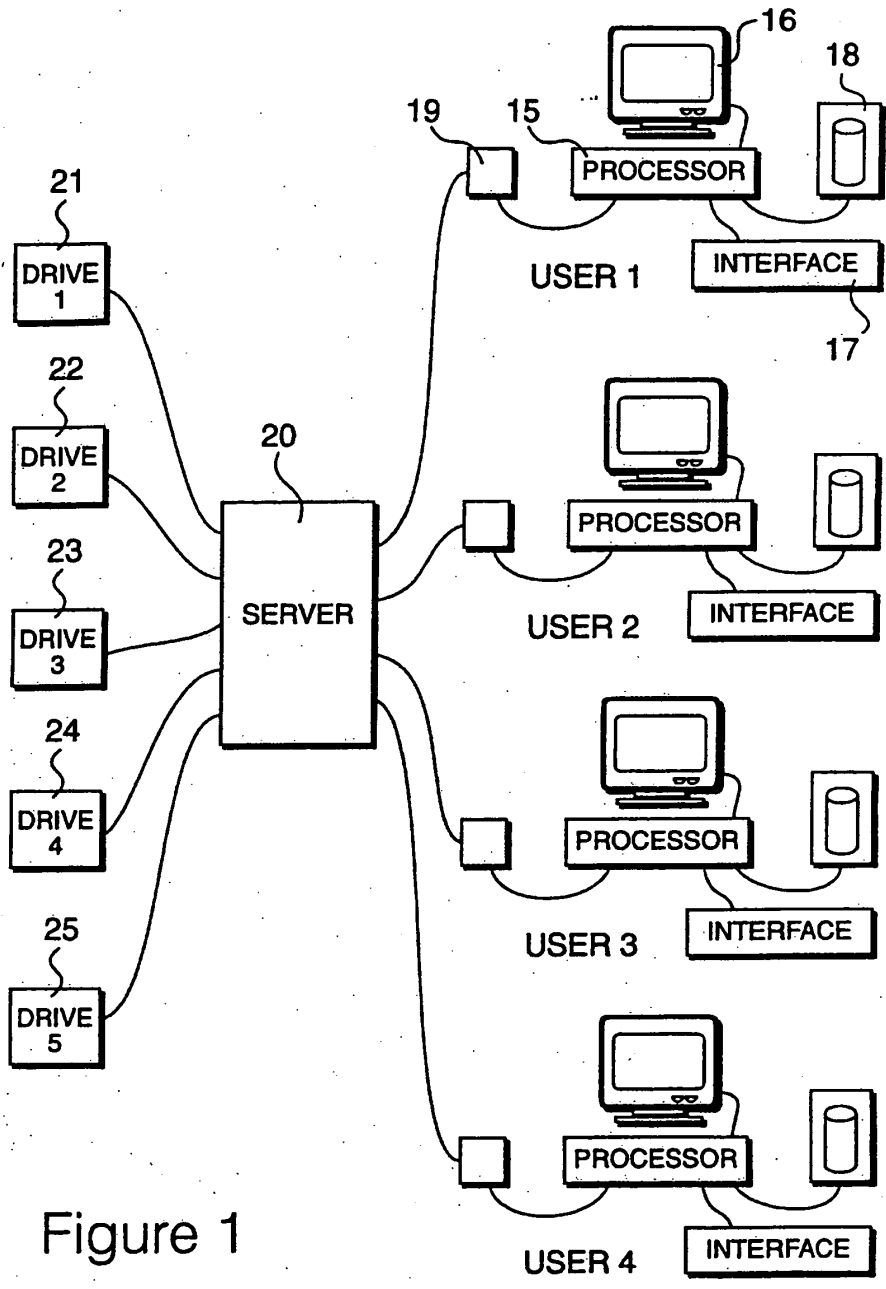

Figure 1

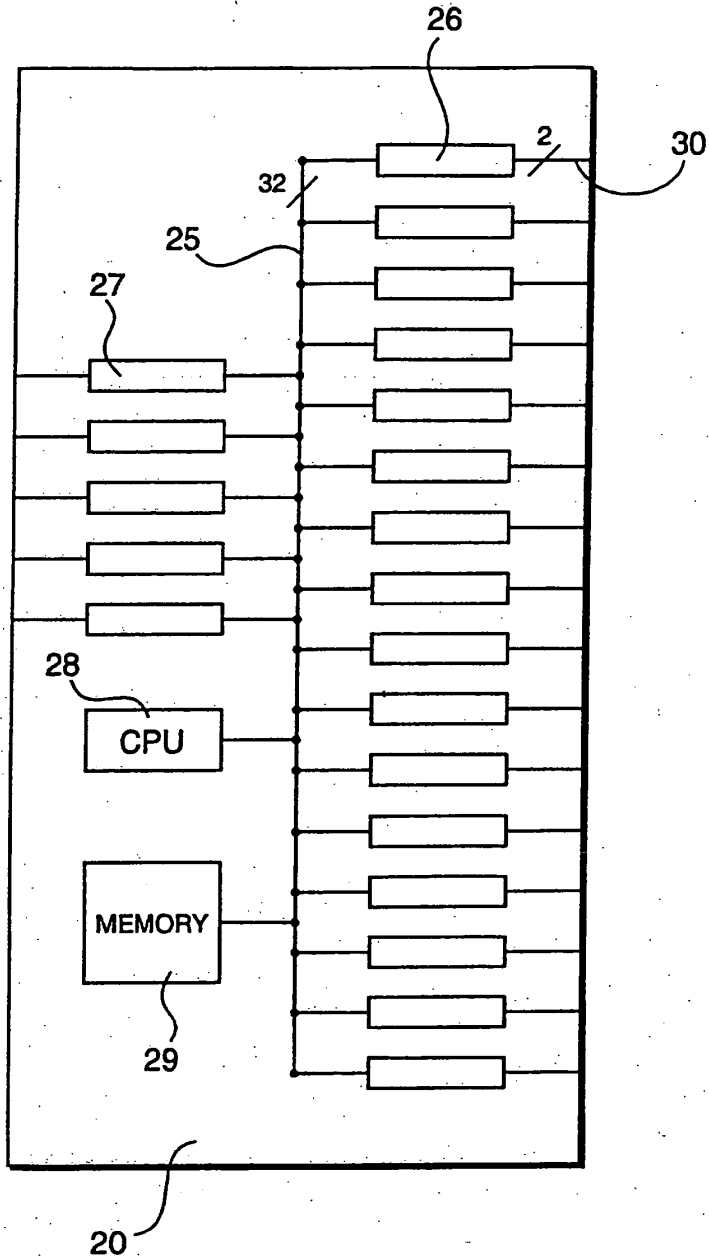

Figure 2

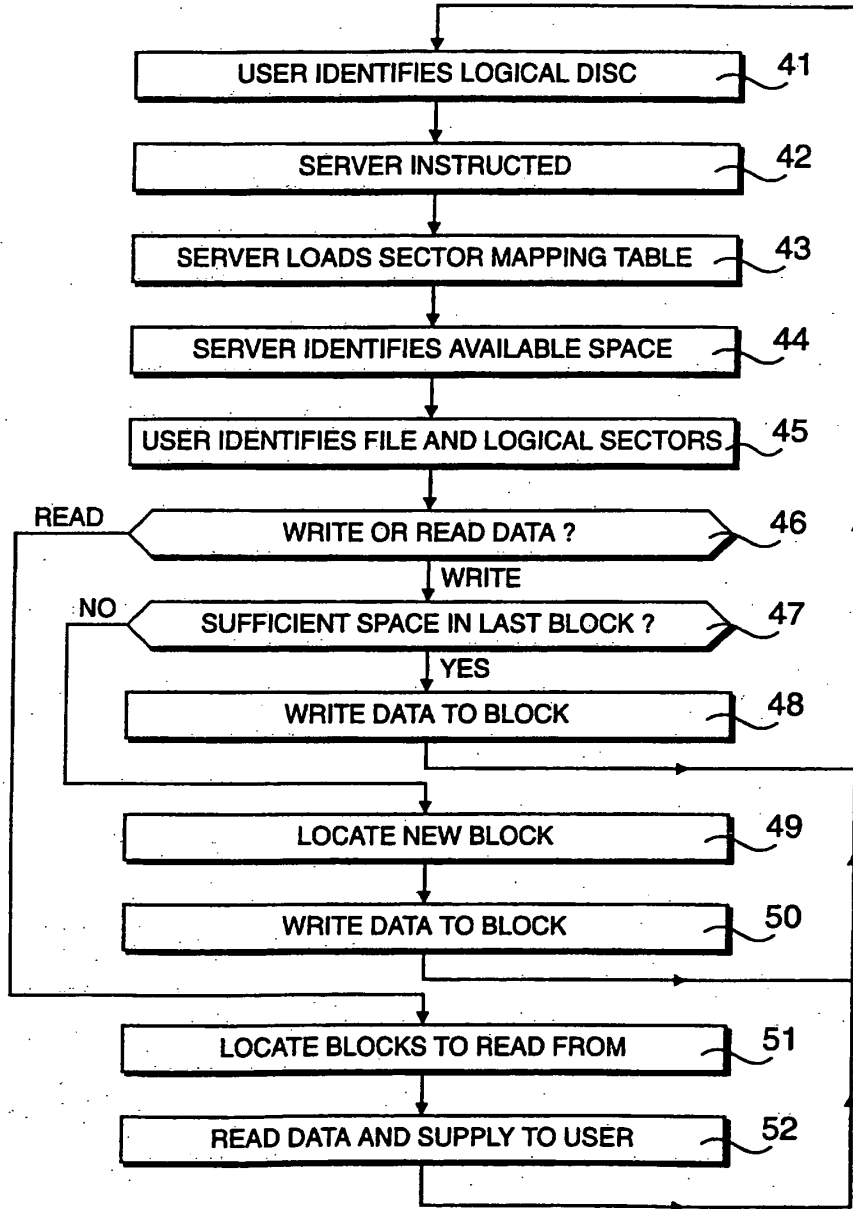

Figure 3

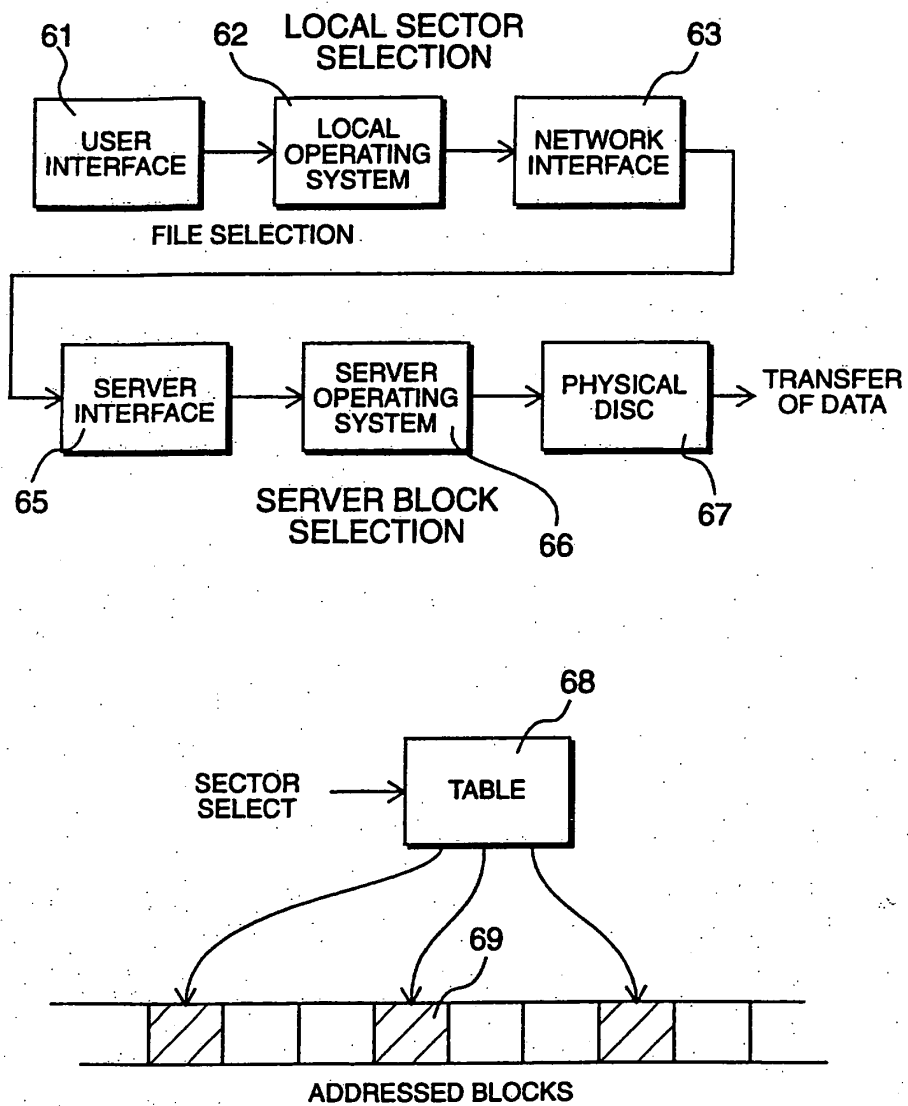

Figure 4

STORING DATA

The present invention relates to storing data. In particular, the present invention relates to an environment in which a plurality of user terminals
5 have shared access to a large storage volume.

Systems are known in which data storing devices, often referred to as volumes, are shared amongst a plurality of user terminals or workstations. Typically, the volume is associated with a local workstation, referred to as a server, and the totality of the workstations are interconnected by a network,
10 such as an ethernet. Such an arrangement provides efficient shared access to files provided that the amount of data contained within each file is small compared to the transmission bandwidth provided by the network. In operation, given that many users may be sharing the network bandwidth, the bandwidth allocated to any one particular user will be significantly less than
15 the theoretical maximum provided by the network. Thus, as files get larger, it is preferable for the workstations to be given direct access to a storage volume such that operational time is not lost while waiting for data to be transferred. For example, an A4 full colour image may consist of a total of 30 Mbytes of data. When transmitted over typical networks, a transfer
20 duration of several minutes may take place before the totality of the data has been received.

A problem with providing direct access to discs is that only one workstation may be given access to the data and in order for the data to be loaded into another machine, it may be necessary to physically move
25 transferrable discs, such as SCSI optical discs. Systems also exist under which a plurality of users may share direct access to a data storage device

and, consequently, measures must be implemented to remove the risk of contention problems. Thus, a particular workstation must release access to a particular file or disc partition before any of the other workstations may be allowed to write to that file.

5 In known systems, system specific software must be loaded into each workstation, so that each workstation is provided with instructions relating to the contention protocols. In addition, a plurality of workstations are given access to the shared volume by effectively dividing the volume into a plurality of partitions. Thus, in this way, a first workstation may write and
10 read data to a first partition of the disc, with a second workstation writing and reading to a second partition of the disc. At a later date, the first workstation may release the first partition, thereby allowing another workstation to be given access to this partition. In this way, a plurality of workstations may each access partitions within the volume without the data needing to be
15 transferred, thereby significantly improving operational performance.

 A problem with the above arrangement is that the partitioning of the disc may result in substantial storage regions being taken up that are only available for one workstation at any one time but do not actually contain valid data. Thus, for example, ten partitions of a very large disc volume may each
20 contain a relatively small amount of data. However, although a substantial amount of empty space remains on the disc, as far as the system is concerned, it would not be possible for this space to be allocated to another workstation, given that, as far as the system is concerned, the storage volume is fully allocated.

25 According to a first aspect of the present invention, there is provided a method of storing data wherein a plurality of user terminals access a large

storage volume, comprising steps of emulating the presence of a logical disc drive having a predetermined capacity; dividing said storage volume into a plurality of storage regions, wherein each of said regions is smaller than the size of an emulated logical disc drive; and mapping physical regions of data to an emulated drive dynamically as additional storage is required, up to said predetermined capacity.

Thus, in accordance with said first aspect, a workstation may be given access to a logical disc drive which it perceives as having a predetermined capacity. For example, the predetermined capacity may be similar to that provided by an optical disc providing 600 Mbytes of storage. However, physical storage locations on the large storage volume are only allocated, region by region, as the workstation demands additional storage through the writing of larger files to the disc.

In a preferred embodiment, a look-up table is associated with each accessible logical drive and a particular look-up table is loaded when its associated logical drive is selected.

According to a second aspect of the present invention, there is provided apparatus for storing data, having a plurality of user terminals and means for each of said terminals to be given access to said stored data, comprising means for emulating the presence of a logical disc drive having a predetermined capacity; means for dividing a storage volume into a plurality of storage regions, wherein each of said regions is smaller than the size of an emulated logical disc drive; and mapping means for mapping said physical regions of data to an emulated drive dynamically as additional storage is required, up to said predetermined capacity.

The system will now be described by way of example only, with reference to the accompanying Figures, in which:

Figure 1 shows an environment in which a plurality of workstations have access to a shared storage volume including a shared file server;

5 Figure 2 details the shared file server identified in Figure 1;

Figure 3 illustrates an application of the system shown in Figure 1; and

Figure 4 shows a schematic representation of the system, including the dynamic allocation of storage regions.

10 An environment in which a plurality of users have access to a shared storage volume is illustrated in Figure 1. In the environment shown in Figure 1, each workstation is provided with a processor 15, a visual display unit 16, an interface device in the form of a keyboard and/or a mouse or trackerball etc. 17 and a local disc drive storage device 18.

15 Each processor 15 is connected to a server interface 19 which allows said processors 15 to communicate with a shared file server 20. The file server 20 is connected to typically five physical hard disc drives 21, 22, 23, 24 and 25. This disc drive combination provides typically thirty-six Gbytes of storage with an access speed of typically 10 Mbytes per second.

20 Disc drives 21 to 25 may be configured as a redundant array, commonly referred to as a redundant array of inexpensive discs (RAID). In the preferred implementation, five discs are provided and the coding used to write data to the disc is commonly referred to as RAID 5. Thus, under this

protocol, redundant data is written to the discs such that if one of the drives becomes inoperable or suffers irretrievable damage, all of the data can be reconstituted from the remaining four drives.

5 Data is written to the drives in the form of identifiable blocks or regions of a predetermined length. The size of these blocks is determined from a trade-off between disc space optimisation and disc fragmentation. However, the system is primarily designed for storing large graphics files, therefore blocks may be quite large and it is proposed that said blocks should have a size between two Mbytes and thirty-two Mbytes. Similarly, it is
10 possible that the block size could be configurable for a particular application.

In operation, a user issues commands under software control which effectively result in a logical drive being made available by the server 20. Communication between the user and the server 20 is effected via the interface 19 and as far as the user is concerned, interface 19 presents a
15 standard small computer serial interface (SCSI) to the processor 15. Once a logical disc has been established, the user may access this drive.

The user's workstation receives data to the effect that it has been given access to a disc of a predetermined size, say 600 Mbytes for example, but in actuality, physical space is only allocated dynamically in regions as storage
20 space for the storage of actual data is required.

Thus, in the system shown in Figure 1 the server does not immediately allocate 600 Mbytes of storage to a user when access to a 600 Mbyte logical drive is requested. Space on drives 21 through 25 is not divided into 600 Mbytes (or similar) partitions. Drives 21 through 25 are divided into blocks

of between two and thirty-two Mbytes and blocks are only written to as data becomes available.

For the benefit of this illustration, it will be assumed that storage space on drives 21 through 25 has been divided into blocks of two Mbytes, thereby making two Mbyte blocks available for data storage purposes. As data is written to the drives, via an interface 19, said data will occupy one of said two Mbyte blocks. As the volume of data increases beyond two Mbytes, the server 20 will identify a new block of two Mbytes and data originating from a user will then continue to be written to this new two Mbyte block. Thus, for example, if a user has written a total of five Mbytes, the server is required to maintain a list of where these five Mbytes actually reside on the drives, in terms of three two-Mbyte blocks. However, as far as the user is concerned, five Mbytes of data have been written to on a logical drive having 600 Mbytes of available capacity.

Data is conventionally written to disc drives in terms of identifiable blocks. As far as the user is concerned, data is written to as blocks on a 600 Mbyte logical drive, which are in turn mapped onto real blocks on the RAID. However, the logical blocks may be written to in a substantially similar way to that in which real drives would be re-written to. Thus, it is not necessary for data to be written to the logical drives in what appears to be a contiguous region of disc space. Although the actual storage allocated for a logical drive is distributed over the RAID, the logical drives may appear, from the user's point of view, to be fragmented themselves. Thus, logical blocks of data may appear displaced over a logical drive, effectively emulating the presence of fragmentation on the logical disc. The system emulates such a situation by providing mapping firstly of blocks to logical drive locations and then mapping from logical drive locations to block locations on the RAID.

Many users may be given access to many virtual drives, allowing data to be accessed via many workstations without actually being transferred over a network. However, when capacity is allocated it is not wasted, in that blocks of two Mbytes are only allocated as actual storage is required.

5 In a preferred embodiment, it is envisaged that a server 20 would allow up to sixteen users to be connected thereto, although provision is made for server boxes to be connected in tandem, thereby providing access to a further 16 users for each box so connected.

10 The server 20 is detailed in Figure 2. Internally, a 32 bit parallel bus 25 provides communication between user interface circuits 26, disc drive interfaces 27, an internal processing unit 28 and internal program and data memory 29.

15 The server 20 is connected to each user interface 19 via a respective interface circuit 26 via two coaxial cables 30, providing a bi-directional link capable of conveying 100 Mbytes per second. Similarly, disc interface circuits 27 provide a parallel access to disc drives 21 through 25 and using connections of this type, it is necessary for disc drives 21 through 25 to be in close proximity to server box 20. In practice, the combination of server 20 along with disc drives 21 through 25 could be housed in a common housing with a shared power supply. However, coaxial cables 30 allow the users to be positioned at a significant distance from the server 20 and the interfaces are such that they will allow runs in excess of 100 metres. Thus, these serial connections are similar or may take advantage of high speed ethernet links.

20

In an alternative embodiment, user processors 15 are connected to the server 20 via conventional SCSI interfaces which, although reducing the overall complexity of the system, also reduce the maximum distance between the server 20 and the processors 15.

5 An application of the system is illustrated in Figure 3. At step 41 a user identifies a logical disc, either by running server related software or, alternatively, in response to manual operations of a device connected to interface 19. Thus, if it is not possible to embed server software within a user's terminal, it is possible to provide interfaces 19 with additional control
10 devices such that, in response to manual operation of switches etc., commands are sent to server 20 so as to establish a logical disc connection.

 Communication of this type, allowing a user to send commands to the server 20, is achieved using vendor unique command blocks, which are data areas provided for specific proprietary applications within the SCSI standard.
15 Thus, in response to user originating commands, the server is instructed at step 42 to the effect that a user requires access to a logical drive.

 For each logical drive which may be made available to the users, it being noted that once a logical drive has been established by any particular user, other users may be given access to it, it is necessary for the server 20
20 to create a sector mapping table for that particular logical drive. Thus, in response to commands generated by a user's processor, establishing logical sectors of a SCSI disc, it is necessary for the server 20 to map these logical sectors onto physical blocks or groups of physical blocks stored within the physical drives 21 through 25. At the CPU 28, reference is made to a look-
25 up table stored within memory 29 which, as previously stated, identifies physical data blocks held by the redundant disc array. Thus, the CPU is

required to generate the sector instructions relevant for the physical drives 21 through 25, which are issued to respective ones of said drives via respective interface circuits 27.

5 Once a user has requested use of a logical drive, the server identifies the space available to the user at step 44, in response to which the user may identify particular files to be written to or read from the logical drive.

10 At step 46 it is determined whether the user wishes to write data to or read data from a logical drive. If data is being written to the drive, an enquiry is made at step 47 as to whether space is available on the last block to be written to. If space is available, data is written to the next identified block at step 48. Alternatively, if sufficient space is not available on the last block, a new block is selected at step 49 and data is written to this block at step 50.

15 If a read operation is identified at step 46, the physical blocks to be read are identified at step 51, the data is read at step 52 and supplied to the requesting user in a suitable form. Thereafter, the process may be repeated and further identifications may be made at step 41.

20 A schematic representation of the system is illustrated in Figure 4. At a workstation, a user is presented with a user interface, capable of providing an environment for allowing existing logical drives to be selected and providing the capacity for new drives to be defined.

The user interface 61 is in turn supported by a local operating system 62. Thus, an operator makes a file selection via user interface 61 and it is

then necessary for the local operating system 62 to generate commands which may be interpreted by the physical storage system.

As far as the local operating system 62 is concerned, the system is making access to conventional SCSI disc drives. Thus, the local operating system 62 communicates with a network interface, illustrated as 63 and physically consisting of interface 19 shown in Figure 1. The network interface 63 receives standard SCSI commands from the local operating system 62 and in turn generates modulated data for transmission over the serial link, shown as 64, connecting the network interface 63 to a server interface 64. A physical representation of server interface 64 is identified in Figure 2 as 26.

The transmission of data between the local operating system 62 and the network interface 63 conforms to establish SCSI protocols. However, the communication between network interface 63 and server interface 64 is internally defined by the system and is designed, in a preferred embodiment, to provide maximum data transfer rates over substantial lengths of cable, such as coaxial cable. Furthermore, the connection between the network interface 63 and the server interface 65 is bi-directional.

The network interface 63 is primarily concerned with driving signals generated by the local operating system 62 so that they may be transmitted over the serial communication link 64. However, the sector indications generated by the local operating system 62 are conveyed to the server interface 65 and it is the server operating system 66 which is required to convert SCSI sector selections into addresses for physical blocks located on the array of physical drives.

Thus, the server operating system 66 supplies addressing signals to the physical discs, identified as 67 whereafter data transfer is effected.

The server operating system 66 converts SCSI sector definitions into addressable physical data blocks by means of a look-up table, identified as 68. A look-up table is defined for each logical drive and when a logical drive is selected by an operator its associated look-up table is loaded to an operating area of memory 29 within the server 20. Thus, within the operating system 66, a logical drive is identified, resulting in a table 68 being loaded. Thereafter, SCSI sector selections are supplied as inputs to said table, which then results in addresses for physical data blocks being generated as outputs. Thus, as illustrated in Figure 4, the table 68 effectively points to addressable data blocks 69 in the array of physical data storing discs 21 through 25.

CLAIMS

1. A method of storing data wherein a plurality of user terminals access a large storage volume, comprising steps of
emulating the presence of a logical disc drive having a predetermined
5 capacity;
dividing said storage volume into a plurality of storage regions,
wherein each of said regions is smaller than the size of an emulated logical
disc drive; and
mapping said physical regions of data to an emulated drive
10 dynamically as additional storage is required, up to said predetermined
capacity.
2. A method according to claim 1, wherein a plurality of logical
drives are accessible to a user.
3. A method according to claim 2, wherein a look-up table is
15 associated with each accessible logical drive and a particular look-up table is
loaded when its associated logical drive is selected.
4. A method according to any of claims 1 to 3, wherein the logical
drives appear to a user system in a form compatible with a local physical disc
drive.
- 20 5. A method according to claim 4, wherein said logical drive is
connected via a small computer serial interface (SCSI).
6. A method according to any of claims 1 to 5, wherein the size
of said regions is variable and pre-set for a particular application.

7. Apparatus for storing data, having a plurality of user terminals and means for each of said terminals to be given access to said stored data, comprising

5 means for emulating the presence of a logical disc drive having a predetermined capacity;

means for dividing a storage volume into a plurality of storage regions, wherein each of said regions is smaller than the size of an emulated logical disc drive; and

10 mapping means for mapping said physical regions of data to an emulated drive dynamically as additional storage is required, up to said predetermined capacity.

8. Apparatus according to claim 7, including means for defining a plurality of logical drives, each accessible to a user.

15 9. Apparatus according to claim 8, including means for defining a look-up table associated with each of said logical drives and means for loading a particular look-up table when its associated logical drive is selected.

10. Apparatus according to any of claims 7 to 9, including means for presenting a logical drive to a system user in a form compatible with a local physical disc drive.

20 11. Apparatus according to claim 10, wherein said logical disc drive is connectable via a small computer serial interface (SCSI).

12. Apparatus according to any of claims 7 to 11, including means for pre-setting the size of said regions for a particular application.

13. Apparatus according to any of claims 7 to 11, wherein the size of said regions is variable in response to operator requests and said means for emulating the presence of the logical drive is arranged to supply data to a user terminal identifying the size of a logical drive being emulated.

5 14. A method of storing data substantially as herein described with reference to the accompanying Figures.

 15. Apparatus for storing data substantially as herein described with reference to the accompanying Figures.



The
Patent
Office

15

Application No: GB 9500173.1
Claims searched: 1-15

Examiner: Mr S J Probert
Date of search: 6 April 1995

Patents Act 1977
Search Report under Section 17

Databases searched:

UK Patent Office collections, including GB, EP, WO & US patent specifications, in: UK CI (Ed.N): G4A AMX Int CI (Ed.6): G06F 12/02 Other: Online Databases : WPI, INSPEC

Documents considered to be relevant:

Category	Identity of document and relevant passage	Relevant to claims
	None	

X Document indicating lack of novelty or inventive step	A Document indicating technological background and/or state of the art.
Y Document indicating lack of inventive step if combined with one or more other documents of same category.	P Document published on or after the declared priority date but before the filing date of this invention.
& Member of the same patent family	E Patent document published on or after, but with priority date earlier than, the filing date of this application.

An Executive Agency of the Department of Trade and Industry

52

(12) UK Patent Application (19) GB (11) 2 297 636 (13) A

(43) Date of A Publication 07.08.1996

(21) Application No 9502377.6

(22) Date of Filing 02.02.1995

(71) Applicant(s)
Spring Consultants Limited
(Incorporated in the United Kingdom)

Unit 5, Ashbrook Mews, Westbrook Street,
BLEWBURY, Oxon, OX11 9QA, United Kingdom

(72) Inventor(s)
Norman Hamilton Burklies
Andrew Paul George Randall

(74) Agent and/or Address for Service
Atkinson & Co
Sixth Floor, High Holborn House, 52-54 High Holborn,
LONDON, WC1V 6SE, United Kingdom

(51) INT CL⁶
G06F 3/06

(52) UK CL (Edition O)
G4A AFS AMX

(56) Documents Cited
EP 0078683 A2
Dialog record 01425541 of UNIX Review, vol. 9, No.4,
April 1991, page 98

(58) Field of Search
UK CL (Edition N) G4A AFS AMX
INT CL⁶ G06F 3/06
ONLINE : WPI, INSPEC, COMPUTER DATABASE

(54) Storing data on emulated, logical, removable, disc drives

(57) Data is stored on a large storage volume implemented as a redundant array of five inexpensive discs (21-25). This volume is controlled so as to emulate the presence of a plurality of logical drives. Workstations (15,16) accessing the drives perceive them as removable SCSI drives. Consequently, when a remote workstation closes access to a previously accessed logical drive, a disc dismount command is generated, as required by a removable disc drive, thereby enabling other workstations to obtain access to that drive.

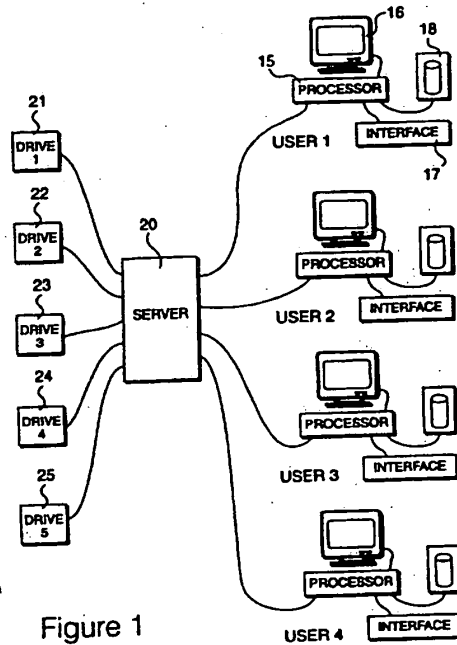

Figure 1

GB 2 297 636 A

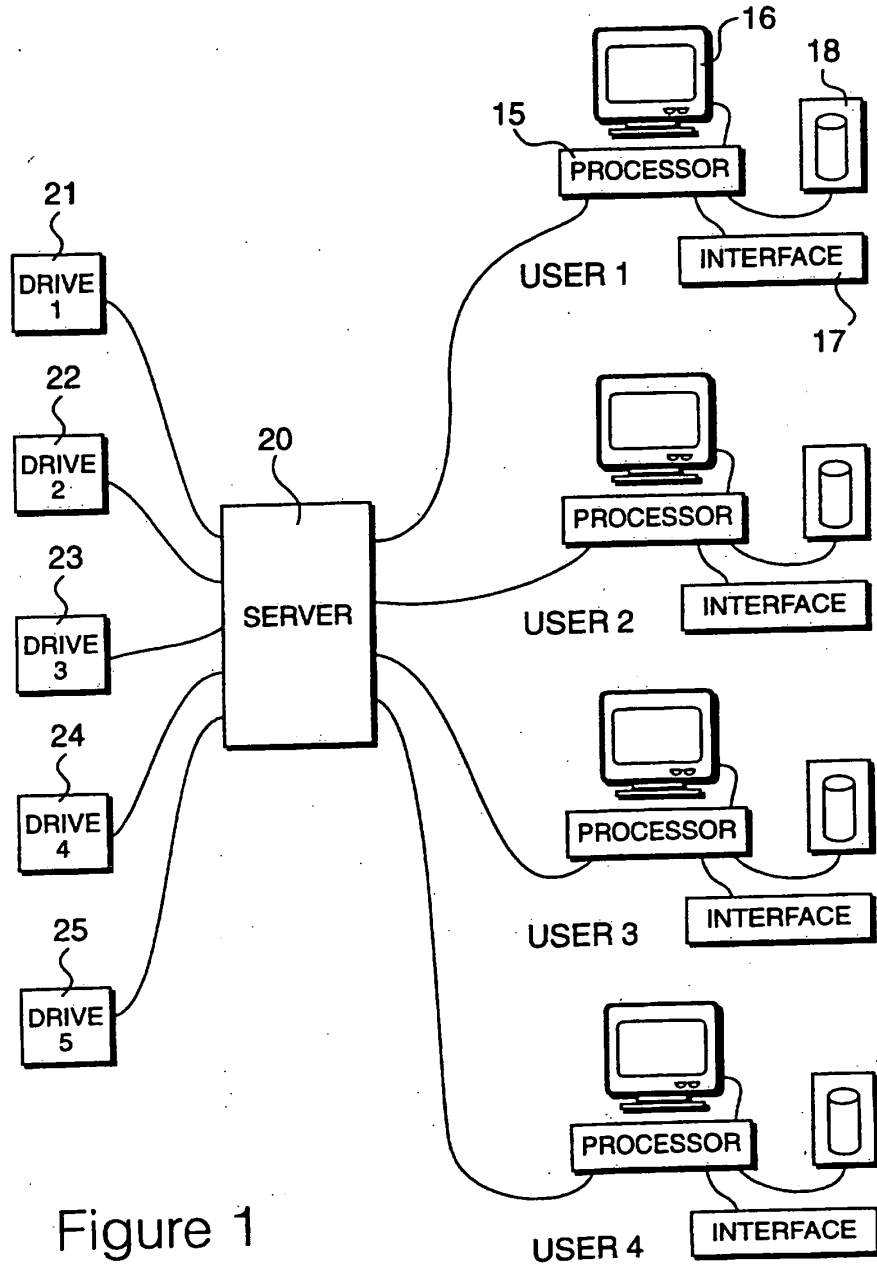

Figure 1

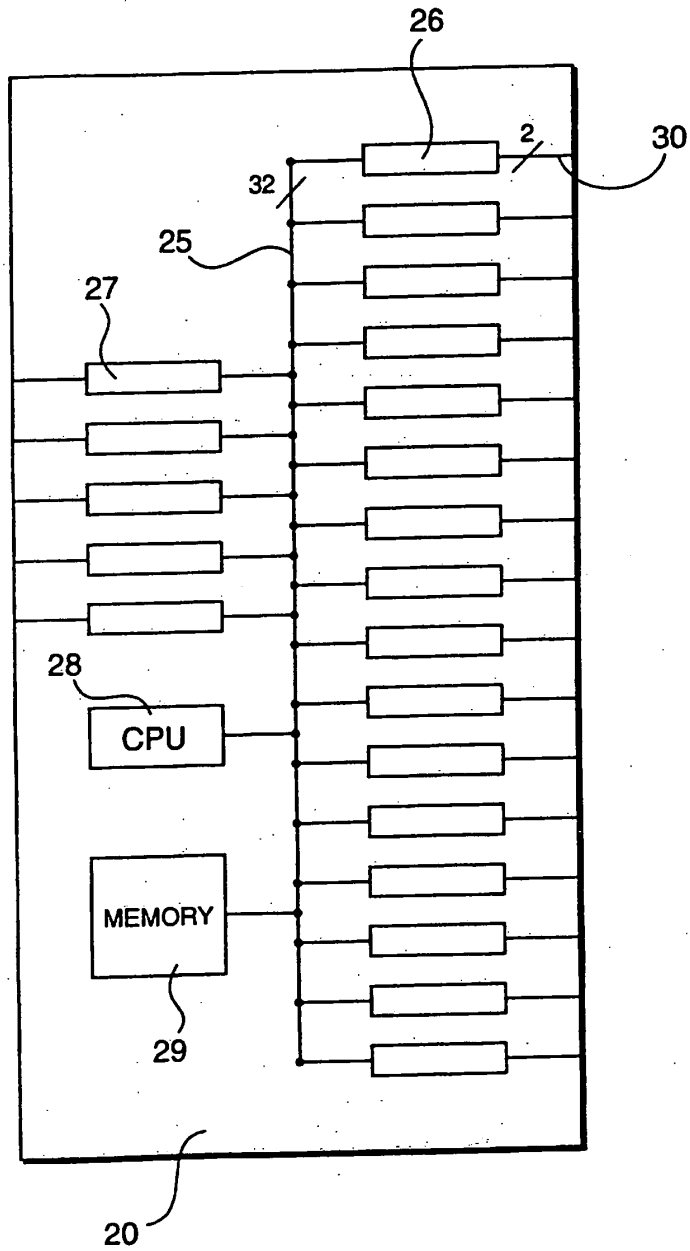

Figure 2

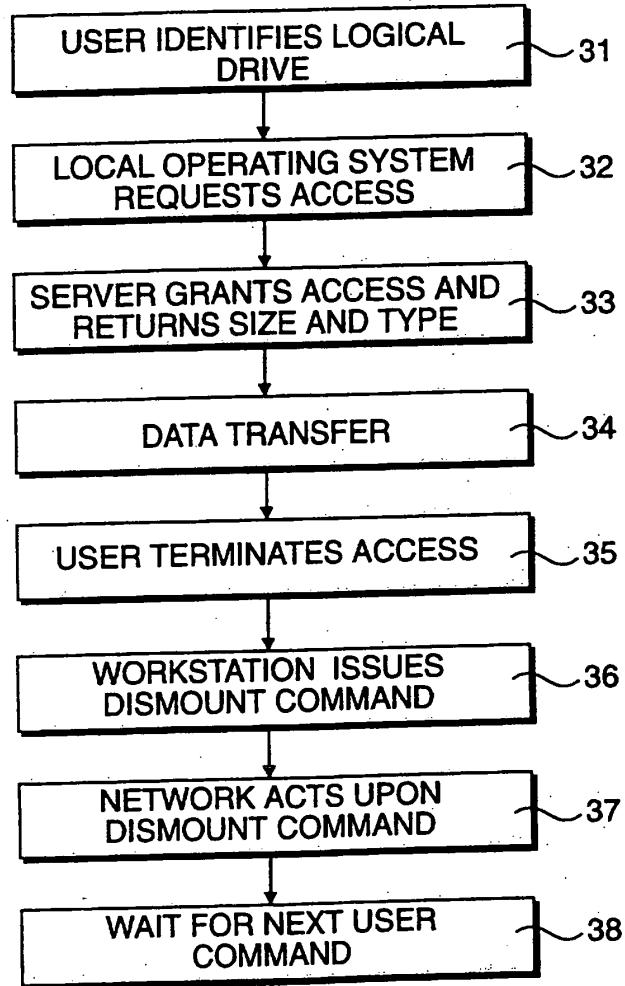

Figure 3

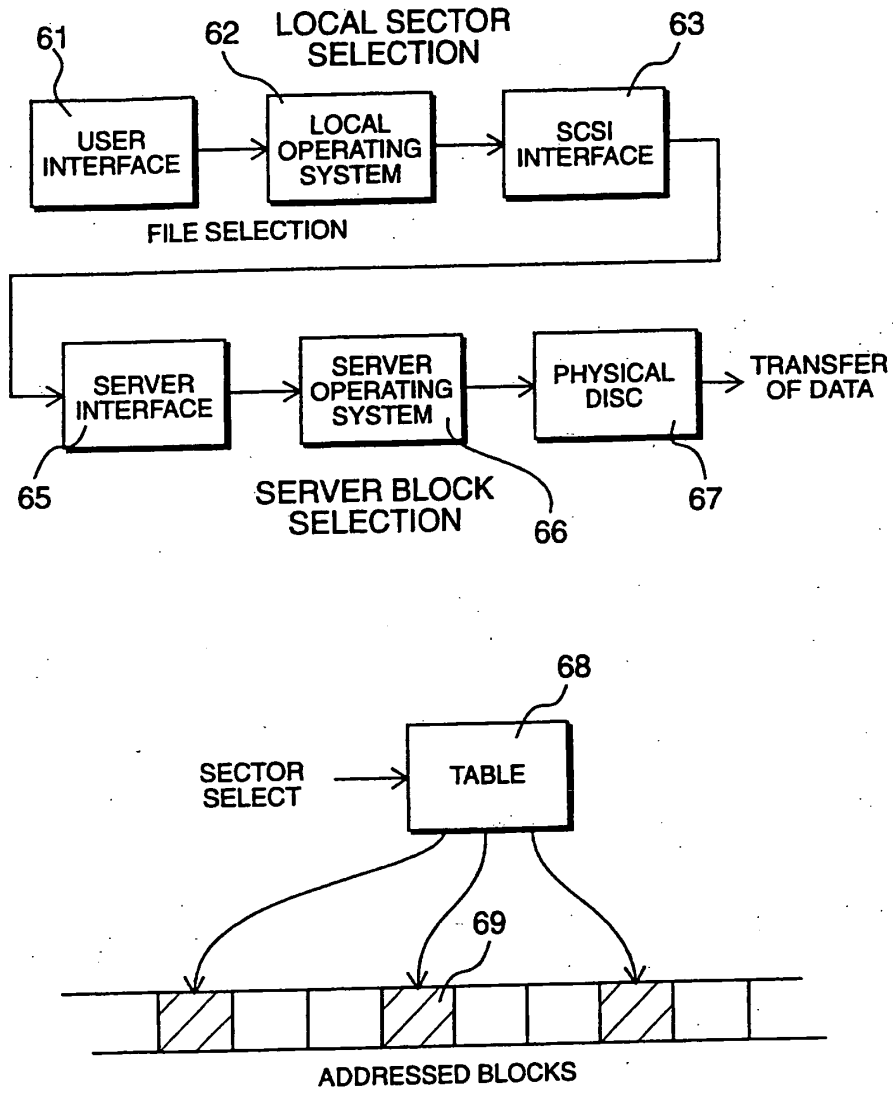

Figure 4

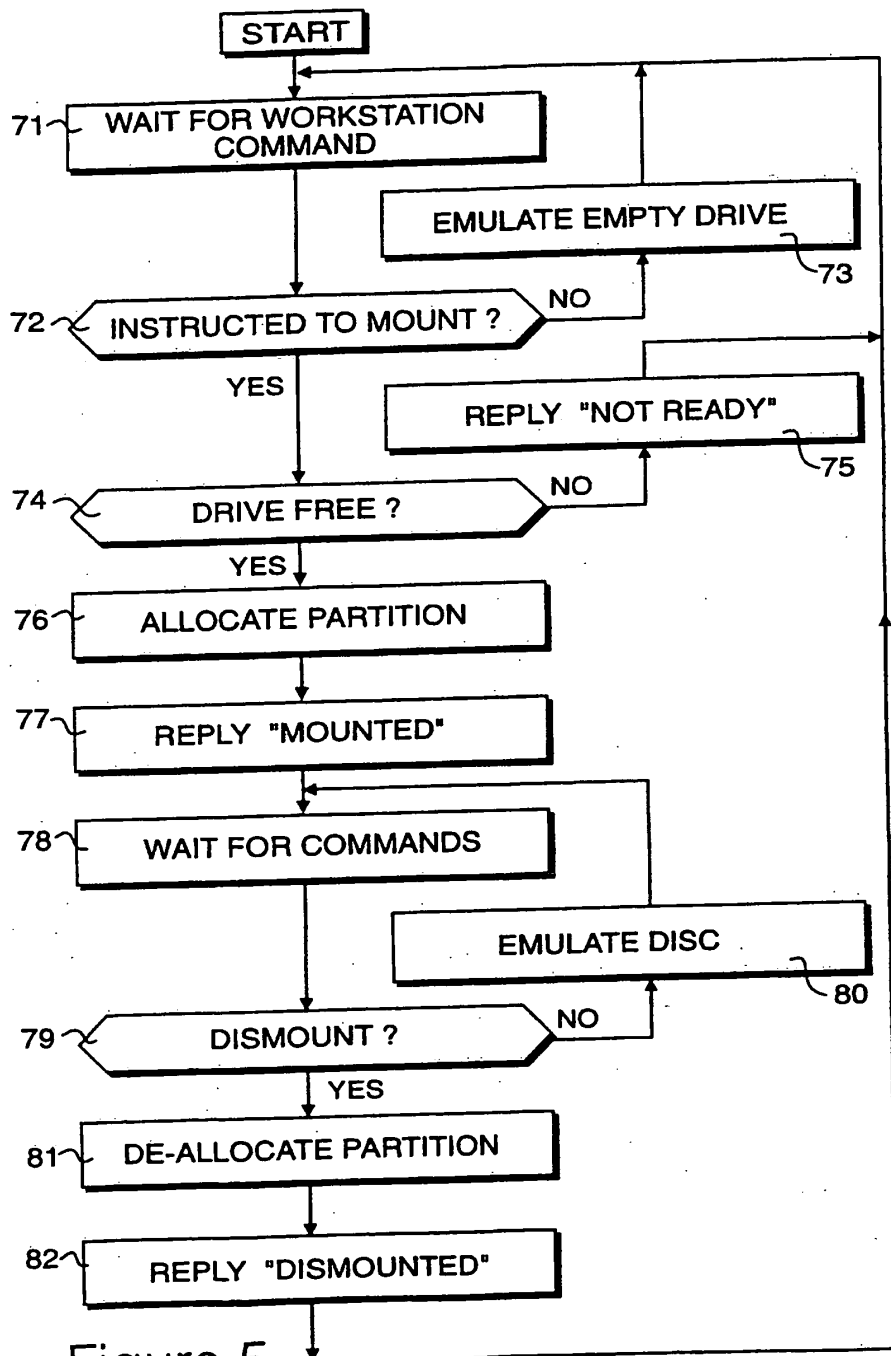

Figure 5

STORING DATA

5 The present invention relates to storing data. In particular, the present invention relates to large storage volumes controlled so as to emulate the presence of a plurality of logical drives.

10 Systems are known in which a large storage volume emulates the presence of a plurality of smaller volumes, which in turn may assist a user by facilitating logical arrangement of data, such that data of a first type may be kept separate from data of a second type. As far as an operating system is concerned, it has access to a plurality of drives as an alternative to having access to only one drive. Most operating systems are capable of controlling a plurality of logical drives in this way; within limits.

15 In more sophisticated environments, it is possible for a plurality of users to be given access to a shared volume divided into a plurality of logical drives. The division of the volume into a plurality of logical drives facilitates the interchange of information between users. Thus, a first user may log onto a logical drive, manipulate data contained within that drive and then log off, so as to allow another user to be given access to the logical drive. Such a procedure is particularly attractive when large data files are being handled, such as data files representing full colour graphic images, where the transfer of data, even over relatively fast networks, may take a considerable amount of time.

20 In addition, a large shared volume may be constructed first to provide relatively fast access times, along with levels of redundancy, such that a

single destructive event would not result in the whole data being lost, with recovery procedures being included as part of the overall structure.

Increasingly, computer workstations are being provided with localised processing capabilities having recognised and well supported operating systems. Examples are Apple Macintosh computers, IBM personal computers and Unix workstations etc. All of these systems have recognised protocols for the transfer of data. Thus, given the abundance of well supported operating systems, it is preferable to take full advantage of these operating systems so as to minimise the degree of bespoke software which needs to be generated and subsequently supported. System designs are restricted if full adherence to existing standards must be maintained, however, in some environments, an established system of operation may already be functional and the extent to which this system may be modified by the addition of new software etc., may be severely restricted. In some situations, the installation of a new suite of networking software may invalidate software agreements relating to primary localised processing.

In an environment in which a large storage volume emulates a plurality of discs, contention problems occur and the control processor must ensure that strict housekeeping routines are maintained, such that, for example, a previously accessed logical drive is properly deactivated when a particular user has finished with it, so that said drive may be accessed by other users and the overall integrity of this system is maintained. However, the degree to which network software requires to be embedded within workstation software should be minimised and it is undesirable for the network to place additional constraints on the workstations so as to assist the network's processing devices with their housekeeping tasks.

According to a first aspect of the present invention, there is provided a method of storing data, wherein a large storage volume emulates a plurality of logical drives; said logical drives emulate removable disc drives; and the closing of access to a previously accessed logical drive generates a disc
5 dismount command.

Thus, an advantage of the present invention is that the logical drives emulated by the large storage volume are presented to users in the form of removable disc drives, although in preferred practical realisations, they would actually be embodied within an environment of large fixed drives, so as to
10 optimise data capacity and disc access speed. However, operating systems for the individual workstations are fully conversant with the requirements of removable disc drives and, as required by the present invention, they will issue commands to said drives, informing the drive that access is no longer
15 required.

In this way, it is possible to ensure that all necessary housekeeping procedures are effected when control over a logical disc drive is relinquished, either as part of normal operations or due to a software or hardware fault. Thus, for example, it is possible to ensure that directory information, cached in memory, is written back to disc, thereby updating the disc's directory,
20 before releasing access to the logical drive. Thus, by emulating removable drives of this type, workstation software will automatically provide the necessary levels of housekeeping in order to ensure that access to a logical drive is released when no longer required by a particular operator.

The local workstation will interface with a logical drive over standard
25 interfaces, provided for accessing removable disc drives. The workstation software will generate a disc dismount command and as far as the said

software is concerned, a dismount of the removable disc will be effected, thereby releasing the tie between the local workstation and that particular logical disc drive. However, within the network, this command will be interpreted to the effect that the processor no longer requires access to the logical drive, thereby allowing housekeeping procedures to be performed by the network processor.

Preferably, the logical drives emulate removable SCSI drives which may be capable of storing between 200 MBytes and 900 MBytes of data. According to a second aspect of the present invention there is provided apparatus, including a large storage volume; a control device arranged to control data transfer with said storage volume and to provide user terminal access to said storage volume by emulating the presence of a plurality of removable disc drives wherein user terminals generate a disc dismount command when closing access to a previously accessed logical drive; and the control device responds to said disc dismount command by terminating connection to said previously connected logical drive.

In a preferred embodiment, the control device is arranged to read directory information from an access logical drive and said directory information stored on the disc is updated in response to a disc dismount command.

The invention will now be described by way of example only, with reference to the accompanying figures, in which:

Figure 1 shows a system in which a plurality of workstations have access to a shared storage volume, including a file server;

Figure 2 details the file server shown in Figure 1;

Figure 3 details operations performed by the system shown in Figure 1; and

Figure 4 represents the logical operations effected by the system shown in Figure 1, including removable disc emulation;

Figure 5 details the removable disc emulation procedures performed by the file server shown in Figure 1.

A system is shown in Figure 1 in which a plurality of users have access to a shared storage volume. At each user workstation, the user is provided with a processor 15, a visual display unit 16, a keyboard, mouse or similar interface device 17 and a local disc drive 18.

Each processor 15 includes conventional software so as to implement an operating system, allowing data transfer between the processor 15 and the disc drive 18. In addition, the operating system also facilitates data transfer between the processors 15 and a shared file server 20. In this preferred embodiment, the file server 20 is connected to five physical hard disc drives 21, 22, 23, 24 and 25, which in combination provide a total of thirty-six GBytes of storage with an access speed of typically 10 MBytes per second.

Disc drives 21 to 25 are configured as a redundant array, in which actual data is stored on four of the drives, with parity data stored on the fifth. In this way, any one of the physical drives 21 to 25 may be removed from the system, possibly due to operational failure (head crash etc.) whereafter said data may be re-constituted from the data available from the other four.

Thus, data integrity and reliability are assured without the need for implementing regular back-up procedures. The use of a plurality of disc drives in this way is known in the art as a redundant array of inexpensive discs. In the preferred embodiment this is implemented in accordance with the RAID 5 recommendation.

Data is written to the drives in the form of identifiable blocks or regions of a predetermined length. The size of these blocks is determined from a trade-off between disc space optimisation and disc fragmentation. The system is primarily designed for storing large full colour graphics files and blocks have a size of, typically, between two MBytes and thirty-two MBytes, although block size may be configurable so as to suit particular applications. In operation, users issue commands under software control which result in logical drives being made available by the server 20. Communication between users and the server 20 is implemented using established protocols. In the preferred embodiment, the standard small computer systems interface (SCSI) is implemented and suitable interface cards are mounted in association with processor 15 and server 20. Thus, once a logical drive has been established by the server 20, this drive may be accessed by the user who perceives the drive as a conventional SCSI drive, accessed via conventional protocols within the local operating system.

The server 20 is arranged to provide access to a total of sixteen user workstations and a further sixteen workstations may be given access by connecting a similar server in tandem with the first. The server is detailed in Figure 2 and, internally, a thirty-two bit parallel bus 25 provides communication between the user interface circuits 26 and disc drive interfaces 27. The server is controlled in response to commands issued by the central

processing unit 28 which in turn receives programmed instructions from an internal memory device 29.

As previously stated, the server 20 is connected to each processor of a user workstation via a SCSI interface. The range of such interfaces is limited and in alternative embodiments it may be necessary to provide alternative connections, possibly via coaxial cables, so as to increase the distance between the server and the workstations. It is therefore envisaged that systems will be designed specifically for particular applications, so as to optimise connections between workstations and the server. Thus, in some environments, a large number of workstations may be provided relatively close to the server 20, in which case conventional SCSI interfaces may be employed whereas, in alternative arrangements, workstations may be distributed quite widely throughout a building, requiring more robust connections between the processors and the server 20. It is envisaged that connections of this type should allow the workstations to be displaced from the server by distances in excess of 100 metres, having characteristics similar to high speed ethernet links.

Typical operation of the system shown in Figure 1 is detailed in Figure 3. As far as the operating system executable by each user workstation is concerned, the workstation effectively has access to a large number of removable disc drives, although these are actually emulated by the server 20. In some situations, standard operating system software interfaces may be implemented within the user workstations so as to allow users to gain access to these logical drives. However, as the number of logical drives increases, it may be necessary to improve the environment provided for users, so that they are aware of the presence of the disc drives and are provided with an interface which facilitates access to them. However, these user interfaces

would be overlaid over the operating system so that computer generated commands would result in instructions being generated at the operating system level.

5 Referring to Figure 3, a user identifies a logical disc drive to which access is required and identifies this logical disc drive at step 31. In response to the local request made at step 31, the local operating system implements measures to effect a request to access the logical disc drive, using conventional protocols. In particular, the processor 15 issues commands over the SCSI interface connected to the server 20.

10 In response to the request made at step 32, the server 20 will determine whether the logical disc drive is available and if the drive is available, it will grant access to the requesting workstation. As part of the SCSI protocol, the server will return data back to the requesting workstation, identifying the size of the logical drive and the drive type. Data relating to the drive type is very
15 relevant to the present invention. In particular, data is returned back to the requesting workstation identifying the drive type as a removable drive having, in the preferred embodiment, a total of 600 MBytes of available capacity.

20 Thus, it should be appreciated, that the emulated drives differ significantly from the actual physical drives in two respects. Firstly, the emulated drives are significantly smaller than the actual physical drives on which they are being emulated, primarily to ensure that a large number of such drives may be supported by the system. Secondly, the physical drives are actually fixed drives and remain permanently in place. Thus, when the server writes data to a particular physical location, the server is assured that
25 this physical location will remain in place and will not be exchanged for some other data storage medium. However, in the emulated environment, the

requesting processors are informed that the drives to which they are writing should be treated removable drives, effectively warning the processor that these drives may be replaced and that a subsequent data transfer operation to that particular drive would not necessarily result in the same information being available on the storage medium.

5

In the system itself, the emulated drives are not physically replaced by other recording media and it is not actually necessary for a physical dismounting operation to be performed when data access has been completed. However, by informing the remote processors that they are dealing with removable disc drives, the resulting dismount or unload command issued by the operating systems of the remote processors will ensure that the server has been instructed to the effect that the remote processors have completed their data transfer operations, thereby ensuring that the processor receives sufficient information for it to complete its housekeeping tasks, thereby allowing other workstations to be given access to emulated drives once they have been released from a data transfer operation.

10

15

Thus, to summarise, when the server 20 grants access to an emulated logical disc drive, it informs the requesting processor that it has been given access to a removable disc drive having a total capacity of 600 MBytes.

20

Conventionally, data is written to disc drives as identifiable blocks. In order to optimise available storage space, these blocks would normally reside on physical drives as contiguous regions of storage, effectively reducing fragmentation. However, it is not essential for the data to be perceived as residing in contiguous regions. In the present embodiment, the workstation processors may write data to the logical disc drives as they feel fit. Thus a logical disc drive may be perceived as being fragmented.

25

Thus, at step 34 data transfer takes place and the workstation's local operating software may read and write to the logical drives as if they were local removable disc drives. However, given the nature of the RAID 5 drives 21 to 25, the rate of data transfer is substantially higher and only restricted by the capabilities of the interface circuits employed. Thus, as far as the workstation processor is concerned, along with its operating software, it is interfacing with a standard removable disc drive. However, as far as the actual operator is concerned, the rate of data transfer is significantly higher and, due to the parallel nature of the array, said transfer rate significantly exceeds that available from fast local hard drives. Thus, the operator is provided with the advantage of fast data access while at the same time allowing data to be shared between a plurality of users as if the data were contained on removable exchangeable drives. Furthermore, the physical removing and exchange of drives is not necessary and only occurs at a logical level.

After data transfer has been completed, a user will normally take measures to terminate access to the logical drive. Thus, at step 35, a user may request access to another drive or implement alternative local processing operations. In either event, the workstation operating system issues a dismount command to the server 20 at step 36. This dismount command is required when the operating system has been given access to real dismountable drives which, as previously stated, is acted upon by the server 20 so as to complete the housekeeping procedures.

At step 37 the server 20 acts upon the dismount command by releasing the logical drive such that it may be accessed by other workstations. Thereafter, at step 38, the server waits for the next user command.

The releasing of a logical drive will include updating the directory for that drive. In order to improve disc access speed, disc directories are cached in memory and directory updates are made locally while the processor has access to the disc. Upon receiving the dismount command, the updated
5 directory information from the cache memory will be rewritten back to the directory on the disc, thereby maintaining the integrity of the directory data stored on the disk.

The system operating the software will be aware of the way in which removable disc directories are handled and the system will include measures
10 for accommodating power failures and program errors etc. Thus, measures can be taken to effect a disc reset, upon detecting that a particular partition has become unavailable or disconnected, whereafter, when access has been regained in that particular drive, information will be read to the effect that no
15 assumptions may be made about the data contained on the disc and it would be necessary to re-assess that data.

Although the system emulates logical drives having, for example, 600 MBytes of available storage, physical space on the RAID 5 drives 21 to 25
20 is actually allocated dynamically in regions as storage space for the storage of actual data is required. Thus, although users appear to be given access to logical drives having a total of 600 MBytes, space on the actual RAID 5
25 drives is not divided into 600 MByte partitions. Drives 21 to 25 are divided into blocks of between two and thirty-two MBytes and blocks are allocated dynamically as and when they are required.

The actual size of blocks on the RAID 5 drives may be variable,
25 although it will be assumed herein that, for a particular application, two MByte blocks will be identified. As data is written to a logical drive, via the

server 20, the data will physically occupy an identifiable two MByte block. As the volume of data increases beyond two MBytes, the server 20 will identify a new two MByte data block and data originating from the user will then be directed to this new block. Thus, if a user has created a total of five
5 MBytes, the server is required to maintain a list of where these five MBytes actually reside on the drives, in terms of three two MByte blocks. However, as far as the user is concerned, five MBytes of data have been written to on a removable drive having a total of 600 MBytes of available capacity.

At a workstation, a user is presented with the user interface capable of
10 providing an environment for allowing existing logical drives to be selected and for new logical drives to be defined. The user interface 61 is in turn supported by a local operating system 62, which is responsible for generating commands which are in turn interpreted by the interface.

As far as the local operating system 62 is concerned, access is being
15 made to a conventional SCSI disc drive and communication is effected over a conventional SCSI interface 63, resident at the workstation, to a server SCSI interface 65. This communication conforms to establish SCSI protocols, thereby substantially reducing the need for embedding bespoke software within the local workstation environments.

20 A server operating system 66 converts SCSI sector definitions into addressable physical data blocks by means of a look-up table, identified by reference 68. A look-up table is defined for each logical drive and when a logical drive is selected by an operator, its associated look-up table is loaded to an operating area of memory 28 within the server 20. Thus, within the
25 server operating system 66, a logical drive is identified, resulting in a table 68 being loaded. Thereafter, SCSI sector selections are supplied as inputs to

the table, which then results in addresses for physical data blocks being generated as outputs. Thus, as illustrated in Figure 4, the table 68 effectively points to addressable data blocks 69 in the array of physical data storing discs 21 to 25.

5 The server operating system 66 allows the SCSI environment of the user terminal to interface with the emulated environment of the server. Thus, it is necessary for the server operating system to emulate an SCSI disc drive and procedures for performing this emulation are detailed in Figure 5.

10 The procedures shown in Figure 5 are executed within a multi-tasking environment, such that similar procedures may be performed for each of the user terminals. The procedures shown in Figure 5 therefore represent instructions executed on behalf of a particular workstation.

15 At step 71 the system waits for a workstation command and upon receiving such a command a question is asked at step 72 as to whether this is a "mount" command. A "mount" command instructs the server to mount a selected removable drive and data transfers via the server 20 can only be performed if the server has received such an instruction. Thus, if the question asked at step 72 is answered in the negative, control is directed to step 73, whereupon procedures are performed to emulate an empty drive. Thus, this would include the generation of error messages to the effect that the drive is not ready etc.

20 If an instruction to mount a drive is generated by the workstation, the question asked at step 72 is answered in the affirmative, resulting in control being directed to step 74. At step 74 a question is asked as to whether the drive is free and if another user workstation has been given access to that

25

particular drive, the question asked at step 74 will be answered in the negative, resulting in a reply being generated at step 75 to the effect that the drive is not ready. Thereafter, control is returned to step 71. However, if the drive is free the question asked at step 74 is answered in the affirmative,
5 resulting in control being directed to step 76.

At step 76 a partition is identified representing the regions within which data for the emulated drive may be read from or written to. Thereafter, control is directed to step 77, whereupon a reply is returned back to the requesting workstation to the effect that the disk has been mounted and
10 control is directed to step 78.

At step 78 the server waits for further commands from the user workstation and in response to receiving such a command, a question is asked at step 79 as to whether this is a dismount command. If the command is not a dismount command further emulation of a removable disc is performed at
15 step 81 and control is returned to step 78.

Upon detecting a dismount command at step 79, control is directed to step 81, whereupon the partition is de-allocated and a reply is issued to the user workstation at step 82 to the effect that the disc has been dismounted. Thereafter control is returned to step 71, whereupon the server waits for the
20 next workstation command.

CLAIMS

1. A method of storing data, wherein a large storage volume emulates a plurality of logical drives; said logical drives emulate removable disc drives; and the closing of access to a previously accessed logical drive
5 generates a disc dismount command.
2. A method according to claim 1, wherein the logical drives emulate removable SCSI drives.
3. A method according to claim 2, wherein each of said logical drives provides between 200 MBytes and 900 MBytes of data storage.
- 10 4. A method according to any of claims 1 to 3, wherein data is written to the physical storage volume in identifiable blocks.
5. A method according to claim 4, wherein each of said blocks provides between one MByte and sixty-four MBytes of storage.
- 15 6. A method according to claim 4 or claim 5, wherein a mapping table maps sectors of an emulated disc onto blocks of the physical volume.
7. A method according to claim 4 or claim 5, wherein blocks are allocated dynamically as storage is required.
8. A method according to any of claims 1 to 7, wherein the storage volume is implemented as an array of disc storage devices.

9. A method according to claim 8, wherein the array has redundant discs.

10. A method according to claim 8 or claim 9, wherein the array has between four and twelve discs.

5 11. A method according to any of claims 1 to 10, wherein directory information stored on an accessed disc is updated in response to a disc dismount command.

10 12. A method according to any of claims 1 to 10, wherein directory information stored on an accessed disc is updated on detecting that a user terminal has been disconnected and can no longer access a previously accessed logical drive.

15 13. Data storage apparatus, including a large storage volume; a control device arranged to control data transfer with said storage volume and to provide user terminal access to said storage volume by emulating the presence of a plurality of removable disc drives, wherein user terminals generate a disc dismount command when closing access to a previously accessed logical drive; and the control device responds to said disc dismount command by terminating connection to said previously connected logical drive.

20 14. Apparatus according to claim 13, wherein the logical drives emulate removable SCSI drives.

15. Apparatus according to claim 14, wherein each of said logical drives provides between 200 MBytes and 900 MBytes of data storage.

16. Apparatus according to any of claims 13 to 15, wherein the control device is arranged to write data to the physical storage volume in the form of identifiable blocks.

5 17. Apparatus according to claim 16, wherein each of blocks provides between 1 MByte and 64 Bytes of storage.

18. Apparatus according to claim 16 or claim 17, wherein the control device is arranged to access mapping tables, mapping sectors of an emulated disc onto blocks of the physical volume.

10 19. Apparatus according to any of claims 16 to 18, wherein the control device is arranged to dynamically allocate blocks as storage is required.

20. Apparatus according to any of claims 13 to 19, where the storage volume is implemented as an array of disc storage devices.

15 21. Apparatus according to claim 20, wherein the array includes redundant discs.

22. Apparatus according to claim 20 or claim 21, wherein the array has between four and 12 discs.

20 23. Apparatus according to any of claims 13 to 22, wherein the control device is arranged to read directory information from an accessed logical drive, and the directory information stored on the disc is updated in response to a disc dismount command.

24. Apparatus according to any of claims 13 to 22, wherein the control device is arranged to read directory information from an accessed logical drive and directory information stored on a logical disc drive is updated by the control device in response to detecting that a user terminal has been disconnected and can no longer access a previously accessed logical drive.

25. A method of storing data substantially as herein described with reference to the accompanying drawings.

26. A data storage apparatus substantially as herein described with reference to the accompanying drawings.



The
Patent
Office

19

Application No: GB 9502377.6
Claims searched: 1-26

Examiner: Geoff Western
Date of search: 3 May 1995

Patents Act 1977
Search Report under Section 17

Databases searched:

UK Patent Office collections, including GB, EP, WO & US patent specifications, in:

UK Cl (Ed.N): G4A (AFS, AMX)

Int Cl (Ed.6): G06F (3/06)

Other: On-line : WPI, INSPEC, COMPUTER DATABASE

Documents considered to be relevant:

Category	Identity of document and relevant passage	Relevant to claims
A	EP-0078683-A2 (FUJITSU) See whole document	-
A	Dialog record 01425541 of UNIX Review, vol 9, No 4, April 1991, page 98	-

X	Document indicating lack of novelty or inventive step	A	Document indicating technological background and/or state of the art.
Y	Document indicating lack of inventive step if combined with one or more other documents of same category.	P	Document published on or after the declared priority date but before the filing date of this invention.
&	Member of the same patent family	E	Patent document published on or after, but with priority date earlier than, the filing date of this application.

An Executive Agency of the Department of Trade and Industry

OS

JP1996230895A

1996-9-10

Bibliographic Fields

Document Identity

(19)【発行国】
日本国特許庁(JP)

(19) [Publication Office]
Japan Patent Office (JP)

(12)【公報種別】
公開特許公報(A)

(12) [Kind of Document]
Unexamined Patent Publication (A)

(11)【公開番号】
特開平8-230895

(11) [Publication Number of Unexamined Application]
Japan Unexamined Patent Publication Hei 8- 230895

(43)【公開日】
平成8年(1996)9月10日

(43) [Publication Date of Unexamined Application]
1996 (1996) September 10*

Public Availability

(43)【公開日】
平成8年(1996)9月10日

(43) [Publication Date of Unexamined Application]
1996 (1996) September 10*

Technical

(54)【発明の名称】
穀類貯蔵用の袋体
(51)【国際特許分類第 6 版】
B65D 30/10

(54) [Title of Invention]
BAG FOR CEREAL STORAGE
(51) [International Patent Classification, 6th Edition]
B65D 30/10

81/20
【FI】
B65D 30/10 B
81/20 B

81/20
【FI】
B65D 30/10 B
81/20 B

【請求項の数】
3

【Number of Claims】
3

【出願形態】
OL

【Form of Application】
OL

【全頁数】
3

【Number of Pages in Document】
3

Filing

【審査請求】
有
(21)【出願番号】
特願平7-39844

【Request for Examination】
*
(21) [Application Number]
Japan Patent Application Hei 7- 39844

(22)【出願日】
平成7年(1995)2月28日

(22) [Application Date]
1995 (1995) February 28*

Parties**Applicants**

(71)【出願人】
 【識別番号】
 595029554
 【氏名又は名称】
 樋口 秀一
 【住所又は居所】
 新潟県三島郡与板町大字本与板3504番地

(71) [Applicant]
 [Identification Number]
 595029554
 [Name]
HIGUCHI HIDEKAZU
 [Address]
 Niigata Prefecture Mishima-gun *sheet *Oaza **sheet
 3504address

Inventors

(72)【発明者】
 【氏名】
 樋口 秀一
 【住所又は居所】
 新潟県三島郡与板町大字本与板3504番地

(72) [Inventor]
 [Name]
 Higuchi Hidekazu
 [Address]
 Niigata Prefecture Mishima-gun *sheet *Oaza **sheet
 3504address

Agents

(74)【代理人】
 【弁理士】
 【氏名又は名称】
 吉井 昭栄 (外2名)

(74) [Attorney(s) Representing All Applicants]
 [Patent Attorney]
 [Name]
 Yoshii *Sakae (2 others)

Abstract

(57)【要約】

【目的】

本発明は米の長期貯蔵を簡単に行い得る穀類貯蔵用の袋体を提供することを目的とする。

【構成】

米、麦、大豆等の穀類を貯蔵する穀類貯蔵用の袋体であって、一側に開口部 1a を形成した袋体 1 を設け、該開口部 1a を適宜な手段により密封可能に構成し、公知の掃除機 2 により内部の空気を吸引する吸引部 3 を該袋体 1 に設けたものである。

(57) [Abstract]

[Objective]

this invention designates that bag for cereal storage which can do long-term storage of rice simply is offered as objective .

[Constitution]

With bag for cereal storage which stores rice , cereal grain , soybean or other cereal , bag 1 which formed opening 1a in one side is provided, said opening part 1a sealing up configuration is possibly done with appropriate means , it is something which provides aspiration part 3 which air of interior is absorbed with cleaner 2 of public knowledge in said bag 1.

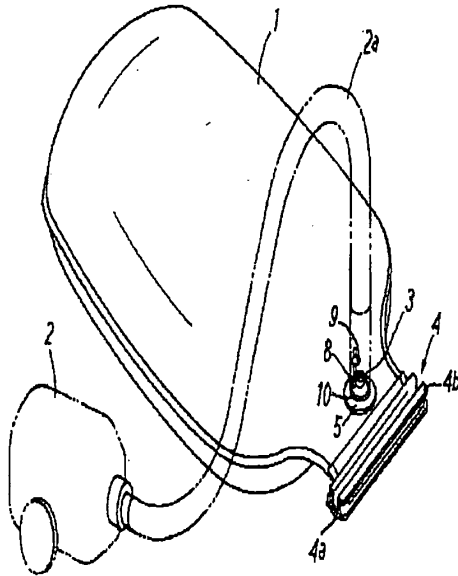

Claims

【特許請求の範囲】

【請求項 1】

米、麦、大豆等の穀類を貯蔵する穀類貯蔵用の袋体であって、一側に開口部を形成した袋体を設け、該開口部を適宜な手段により密封可能に構成し、公知の掃除機により内部の空気を吸引する吸引部を該袋体に設けたことを特徴とする穀類貯蔵用の袋体。

【請求項 2】

請求項 1 記載の穀類貯蔵用の袋体において、袋体の開口部を基部に対して巾細に形成したことを特徴とする穀類貯蔵用の袋体。

【請求項 3】

請求項 1,2 いずれか 1 項に記載の穀類貯蔵用の袋体において、袋体の開口部を挾持する挾持体を設けたことを特徴とする穀類貯蔵用の袋体。

Specification

【発明の詳細な説明】

【0001】

[Claim(s)]

[Claim 1]

With bag for cereal storage which stores rice , cereal grain , soybean or other cereal , bag which formed opening in one side is provided, said opening part sealing up configuration is possibly done with appropriate means , bag . for cereal storage which designates that aspiration part which air of interior is absorbed with cleaner of public knowledge is provided in the said bag as feature

[Claim 2]

In bag for cereal storage which is stated in Claim 1, the opening of bag was formed in width detail vis-a-vis base the bag . for cereal storage which designates that as feature

[Claim 3]

In bag for cereal storage which is stated in Claim 1 , 2 any one claim , the bag . for cereal storage which designates that clamps which the opening of bag clamping is done is provided as feature

[Description of the Invention]

【0001】

【産業上の利用分野】

本発明は、米、麦、大豆等の穀類を長期間貯蔵するに便利な穀類貯蔵用の袋体に関するものである。

【0002】

【従来技術及び発明が解決しようとする課題】

従来、米、麦、大豆等の穀類を長期間貯蔵する袋体として、袋体内に脱酸素剤を配設する穀類貯蔵専用の袋体(以下、従来例)が提案されている。

【0003】

この従来例は、袋体の下方に透明なフィルムを貼着して内部が視認できる窓部を形成し、この袋体の中に米等の穀類を収納したら脱酸素剤を当該窓部位置に配設し、脱酸素剤の変色(酸素を吸着すると変色する。)を視認しながら米等を長期間貯蔵するものである。

【0004】

しかしながら、脱酸素剤は酸素の吸着作用が所定期間しか発揮されず、よって、当該従来例の場合、適宜脱酸素剤を交換しなければならない。

【0005】

ところで、この脱酸素剤の交換には当然袋体の開け閉めが伴うことになるが、この袋体の開け閉めにより酸素が少なくなっている袋体内に再び酸素が流入し、従って、また、一から酸素の吸着除去をしなければならず、結局、この穀物貯蔵専用の袋体は無駄が多く、非効率的である。

【0006】

本発明は問題を解決した穀類貯蔵用の袋体を提供するものである。

【0007】

【課題を解決するための手段】

添付図面を参照して本発明の要旨を説明する。

【0008】

米、麦、大豆等の穀類を貯蔵する穀類貯蔵用の袋体であって、一側に開口部 1a を形成した袋体 1 を設け、該開口部 1a を適宜な手段により密封可能に構成し、公知の掃除機 2 により内部の空

[Field of Industrial Application]

rice, cereal grain, soybean or other cereal long period it stores this invention, it is something regarding the bag for convenient cereal storage.

【0002】

[Prior Art And Problems To Be Solved By The Invention]

Until recently, bag (Below, Prior Art Example) of cereal storage dedicated which arranges oxygen scavenger inside bag long period is stored rice, cereal grain, soybean or other cereal as bag which, is proposed.

【0003】

As for this Prior Art Example, adhering doing transparent film in lower of bag, interior when window portion which visible it is possible is formed and rice or other cereal is stored up in this bag, while arranging oxygen scavenger in the this said window portion position, visible doing color change (When oxygen it adsorbs, it changes color.) of oxygen scavenger it is something which rice etc long period is stored.

【0004】

But, oxygen scavenger is shown, depends and adsorption action of oxygen only the specified time when it is a this said Prior Art Example, must exchange as needed oxygen scavenger.

【0005】

It means that by way, opening closing of bag accompanies exchange of this oxygen scavenger naturally, but oxygen flows into the bag where oxygen has decreased depending upon opening closing of this bag again, therefore, in addition, if adsorptive elimination of oxygen is not done from one, it does not become, after all, as for bag of this grain storage dedicated waste is many, it is a inefficient.

【0006】

this invention is something which offers bag for cereal storage which solves problem.

【0007】

[Means to Solve the Problems]

Referring to attached figure, you explain gist of this invention.

【0008】

It is something which relates to bag for cereal storage which designates that aspiration part 3 where with bag for cereal storage storing rice, cereal grain, soybean or other cereal, it provides bag 1 which formed opening 1a in the one

気を吸引する吸引部 3 を該袋体 1 に設けたことを特徴とする穀類貯蔵用の袋体に係るものである。

【0009】

請求項 1 記載の穀類貯蔵用の袋体において、袋体 1 の開口部 1a を基部に対して巾細に形成したことを特徴とする穀類貯蔵用の袋体に係るものである。

【0010】

請求項 1,2 いずれか 1 項に記載の穀類貯蔵用の袋体において、袋体 1 の開口部 1a を挟持する挟持体 4 を設けたことを特徴とする穀類貯蔵用の袋体に係るものである。

【0011】

【作用】

袋体 1 に米等の穀類を収納し、開口部 1a を適宜な手段で密封し、吸引部 3 に公知の掃除機 2 を連設して袋体 1 内の空気を吸引する。

【0012】

【実施例】

図面は本発明の一実施例を図示したもので、以下に説明する。

【0013】

本実施例の袋体 1 は適度に強度を有する透明な合成樹脂部材で成形する。

該袋体 1 の上部は先細り状に形成され、この先細り部の端部が開口部 1a に設定される。

【0014】

この開口部 1a は適宜な合成樹脂で成形した挟持凹体 4a と挟持凸体 4b からなる公知の挟持体 4 により挟持する。

具体的には挟持凹体 4a の凹条に挟持凸体 4b の凸条を嵌入して両者により開口部 1a を閉塞する。

【0015】

袋体 1 の上端側には吸引部 3 が形成されている。

この吸引部 3 は袋体 1 に付設される合成樹脂製の止着体 8 に突設されている。

side, sealing up configuration does said opening part 1a possibly with the appropriate means, absorbs air of interior with cleaner 2 of public knowledge is provided in said bag 1 as feature.

[0009]

In bag for cereal storage which is stated in Claim 1, the opening 1a of bag 1 was formed in width detail vis-a-vis base it is something which relates to bag for cereal storage which designates that as feature.

[0010]

It is something which relates to bag for cereal storage which designates that clamps 4 which opening 1a of bag 1 clamping is done is provided as feature in bag for cereal storage which is stated in Claim 1, 2 any one claim.

[0011]

[Working Principle]

rice or other cereal is stored up in bag 1, opening 1a is sealed up with the appropriate means, cleaner 2 of public knowledge is connected to aspiration part 3 and air inside bag 1 is absorbed.

[0012]

[Working Example(s)]

Being something which illustrates one Working Example of this invention, you explain drawing below.

[0013]

As for bag 1 of this working example it forms with transparent synthetic resin member which possesses strength moderately.

upper part of said bag 1 is formed by taper, end of this taper section is set to opening 1a.

[0014]

clamping it does this opening 1a with clamping concave body 4 a and clamps 4 formed with appropriate synthetic resin of public knowledge which which consists of clamping convex body 4 b.

Inserting convex stripe of clamping convex body 4 b in recessed rib of clamping concave body 4 a concretely, opening 1a it is plugged by both.

[0015]

aspiration part 3 is formed to top end of bag 1.

this aspiration part 3 is installed in a fixing body 8 of synthetic resin which is installed in bag 1.

この止着体 8 は袋体 1 に穿設された窓孔位置に止着されるものであって、止着体 8 の外周に繞設した止着板 5 で窓孔周縁を挾持して袋体 1 に止着される。

符号 6 は弁、7 は米等が吸引されることを防止するフィルター、9 は栓、10 は掃除機 2 の吸引ホース 2a を隙間なく可及的に密着状態にする為の柔軟板である。

[0016]

本実施例は上述のように構成したから、袋体 1 内に例えば米を収納し、該袋体 1 の開口部 1a を挾持体 4 で挾持して袋体 1 を密封する(開口部 1a は折り返して挾持する。)

この密封された状態で袋体 1 の吸引部 3 に掃除機 2 の吸引ホース 2a を被嵌してその下端を柔軟板 10 に当接せしめ、掃除機 2 を作動させて袋体 1 内の空気を吸引すると、袋体 1 内は排気され可及的に真空状態となる。

[0017]

よって、米を長期間貯蔵する場合には適宜掃除機 2 で袋体 1 内を排気するという簡単な作業で済むことになる。

[0018]

また、本実施例の吸引部 3 は弁 6 が設けられている為、袋体 1 内の真空状態が不良となって再吸引する際、栓 9 を開放しても袋体 1 内に空気が流入することは確実に防止され、前記した従来例に比し効率的に米の貯蔵が行い得ることになる。

[0019]

更に、本実施例は酸素のみを消失させる従来例とは異なり、空気を消失させ、真空状態を作出するものであるから、袋体 1 の容積が減少し、それだけ袋体 1 の保管スペースが少なくて済むことになるとともに袋体 1 内の水分も除去され、この点においても米の良好な長期貯蔵が可能となる。

[0020]

[発明の効果]

本発明は上述のように構成したから、米等の穀類の長期貯蔵を且つ良好簡単に行い得る秀れた穀類貯蔵用の袋体となる。

this affixing body 8 being something which affixing is done in window hole position which is installed in bag 1, in outer perimeter of affixing body 8 the clamping doing window hole surrounding edge with affixing sheet 5 which * facilities itdoes, affixing is done in bag 1.

As for sign 6 as for valve , 7 as for filter , 9 which prevents thefact that rice etc is absorbed as for plug , 10 it is a softening sheet inorder to designate suction hose 2a of cleaner 2 if possible as closely adhered state without gap .

[0016]

Because above-mentioned way configuration it did this working example , for example rice is stored up inside bag 1, opening 1a of said bag 1 clamping isdone with clamps 4 and bag 1 is sealed up (Turning back, clamping it does opening 1a.).

this with state which is sealed up fitted covering doing suction hose 2a of cleaner 2 in aspiration part 3 of bag 1, bottom end contacting the softening sheet 10, cleaner 2 operating, when it absorbs air inside the bag 1, inside of bag 1 is done and exhaust if possiblebecomes vacuum state .

[0017]

Depending, when long period it stores rice , it means that insufficient simple operation that exhaust it does inside bag 1 with theas needed cleaner 2.

[0018]

In addition, as for aspiration part 3 of this working example because valve 6 isprovided, vacuum state inside bag 1 becoming defect , whenre-absorbing, opening plug 9, as for air flowing into the bag 1 it is prevented securely, before it compares to Prior Art Example whichwas inscribed and it means to be possible to store rice in the efficient .

[0019]

Furthermore, because as for this working example only oxygen it disappears, itis something which produces vacuum state , volume of bag 1 decreases, as it means that that much storage space of bag 1 may belittle and also moisture inside bag 1 is removed air unlike Prior Art Example which disappears, Satisfactory long-term storage of rice becomes possible at this point.

[0020]

[Effects of the Invention]

Because above-mentioned way configuration it did this invention, it becomes bag for cereal storage which and can do long-term storage of the rice or other cereal satisfactorily simply, is superior.

【図面の簡単な説明】

[Brief Explanation of the Drawing(s)]

【図1】

[Figure 1]

本実施例の斜視図である。

It is an oblique view of this working example .

【図2】

[Figure 2]

本実施例の要部の断面図である。

It is a sectional view of principal part of this working example .

【図3】

[Figure 3]

本実施例の使用状態を示す斜視図である。

It is an oblique view which shows use state of this working example .

【符号の説明】

[Explanation of Symbols in Drawings]

1

1

袋体

bag

1a

1a

開口部

opening

2

2

掃除機

cleaner

3

3

吸引部

aspiration part

4

4

挟持体

clamps

Drawings

【図1】

[Figure 1]

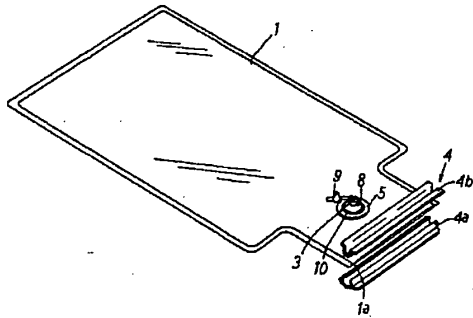

【図2】

[Figure 2]

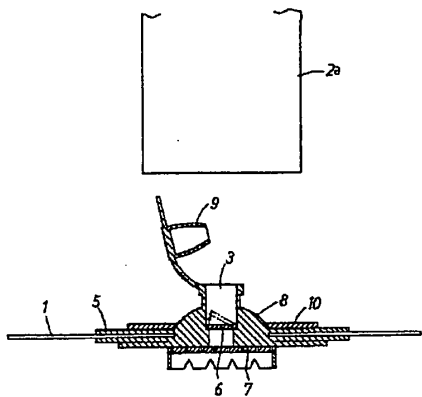

【図3】

[Figure 3]

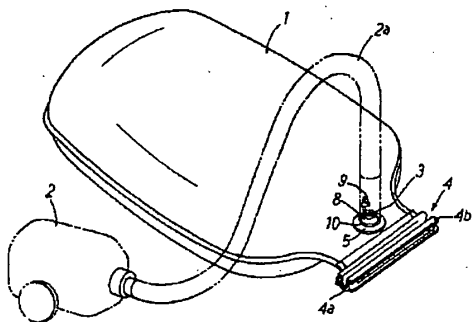

154

(19)  **Europäisches Patentamt**
European Patent Office
Office européen des brevets



(11) **EP 0 810 530 A2**

(12) **EUROPEAN PATENT APPLICATION**

(43) Date of publication:
03.12.1997 Bulletin 1997/49

(51) Int. Cl.⁶: **G06F 13/368**

(21) Application number: **97107935.5**

(22) Date of filing: **15.05.1997**

(84) Designated Contracting States:
DE FR GB NL SE

(30) Priority: **31.05.1996 US 656641**

(71) Applicant:
SUN MICROSYSTEMS, INC.
Mountain View, CA 94043 (US)

(72) Inventors:
• **Schmahl, Kenneth A.**
San Jose, CA 95136 (US)
• **Tedone, Matthew J.**
Sunnyvale, CA 94087 (US)

• **Schell, John C.**
Sunnyvale, CA 94087 (US)
• **Karminsky, Igor**
San Jose, CA 95129 (US)
• **Chan, Ray P.**
Cupertino, CA 95014 (US)

(74) Representative:
Zangs, Rainer E., Dipl.-Ing. et al
Hoffmann Eitle,
Patent- und Rechtsanwälte,
Arabellastrasse 4
81925 München (DE)

(54) **A method and apparatus for passing bus mastership**

(57) A method for passing mastership of a bus is described. According to the method, it is determined whether to use the bus. If the bus is to be used, it is determined whether the bus is available. If the bus is available, the bus is accessed and a signal is generated to indicate that the bus is being accessed. A timer is also started and access to the bus is yielded when the timer expires. A processor that passes mastership to a shared resource is also described. The processor comprises a resource accessing unit. The resource accessing unit allows the processor to access a resource upon receiving a first signal from a component coupled to the resource. The resource accessing unit yields access of the resource to the component upon receiving a second signal from the component.

FIG. 7

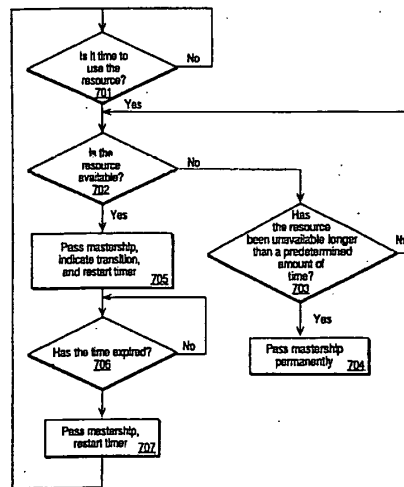

EP 0 810 530 A2

Description**FIELD OF THE INVENTION**

The present invention pertains to the field of bus regulation. More specifically, the present invention relates to an apparatus and method for passing bus mastership between multiple devices.

BACKGROUND OF THE INVENTION

When multiple devices reside on a bus, coordination of access to the bus is necessary. Coordination of access to the bus insures that multiple devices desiring to communicate will not assert control and data lines for different transfers at the same time and cause bus contention.

One approach to coordinating bus access is the use of one or more bus masters in the system. A bus master controls access to the bus. It initiates and controls all bus requests. A processor must be able to initiate a bus request for access to a memory device and thus is always a bus master. A memory device is usually a slave since it will respond to read and write requests but never generate its own requests.

A bus has multiple masters when there are multiple central processing units (CPUs) or when input/output (I/O) devices can initiate a bus transaction. If there are multiple masters, an arbitration scheme is required among the masters to decide who gets the bus next. A bus arbiter is typically used to implement the arbitration scheme. In a bus arbitration scheme, a device wanting to use the bus signals a bus request and is later granted the bus. After a grant, the device can use the bus, later signaling to the bus arbiter that the bus is no longer required. The bus arbiter can then grant the bus to another device. Most multiple-master buses have a set of bus signals for performing requests and grants. A bus release line is also needed if each device does not use its own request line to release the bus. Sometimes the signals used for bus arbitration have physically separate lines, while in other systems the data lines of the bus are used for this function. Arbitration is often a fixed priority, as is the case with daisy-chained devices or an approximately fair scheme that randomly chooses which master gets the bus.

The use of a bus arbiter has several drawbacks. The addition of a bus arbiter requires additional power to operate. This is a problem for computer systems operating under tight power constraints. Implementing a bus arbiter also requires additional space in the computer system. Thus, depending upon the environment of the computer system, the availability of physical space may not permit the implementation of a bus arbiter. Perhaps most importantly, the use of an additional component for the purpose of arbitration adds an undesirable cost to the overall computer system.

Thus, what is needed is an apparatus that passes ownership of a resource between a plurality of devices

without using an external arbiter.

SUMMARY OF THE INVENTION

A method for passing mastership of a resource is described. According to the method, it is determined whether to use the bus. If the bus is to be used, it is determined whether the bus is available. If the bus is available, the bus is accessed and a signal is generated to indicate that the bus is being accessed. A timer is also started and access to the bus is yielded when the timer expires.

A processor that passes mastership of a shared resource is described. The processor comprises a resource accessing unit. The resource accessing unit allows the processor to access a resource upon receiving a first signal from a component coupled to the resource. The resource accessing unit yields access of the resource to the component upon receiving a second signal from the component. The processor further comprises a signal generation unit. The signal generation unit is coupled to the resource accessing unit. The signal generation unit generates a third signal when the processor has gained access to the resource and generates a fourth signal when the processor has yielded access to the resource.

BRIEF DESCRIPTION OF THE DRAWINGS

The present invention is illustrated by way of example and not by way of limitation in the figures of the accompanying drawings, in which like references indicate similar elements and in which:

- Figure 1 illustrates a multi-processor computer system implementing an embodiment of the invention;
- Figures 2 illustrates processors from two different computer systems implementing an embodiment of the invention;
- Figures 3 illustrates the present invention as implemented in a mass storage system;
- Figure 4 is a table illustrating the mastership states in one embodiment of the present invention;
- Figure 5 is a state diagram illustrating the transition order of the states illustrated in Figure 4;
- Figure 6 illustrates a block diagram of one embodiment of a processor implementing the present invention; and
- Figure 7 is a flow chart illustrating a method of passing mastership of a shared resource.

DETAILED DESCRIPTION

A method and apparatus for accessing data in a memory is described. In the following description, for the purposes of explanation, numerous specific details are set forth in order to provide a thorough understanding of the present invention. It will be apparent, however, to one skilled in the art that the present invention may

be practiced without these specific details. In other instances, well-known structures and devices are shown in block diagram form in order to avoid unnecessarily obscuring the present invention.

Referring to Figure 1, the computer system upon which the preferred embodiment of the present invention can be implemented is shown as 100. Computer system 100 comprises a bus or other communication means 101 for communicating information, and processors 102 and 103 coupled with bus 101 for processing information. System 100 further comprises a random access memory (RAM) or other dynamic storage device 104 (referred to as main memory), coupled to bus 101 for storing information and instructions to be executed by processors 102 and 103. Main memory 104 also may be used for storing temporary variables or other intermediate information during execution of instructions by processors 102 and 103. Computer system 100 also comprises a read only memory (ROM) and/or other static storage device 106 coupled to bus 101 for storing static information and instructions for processors 102 and 103. Data storage device 107 is coupled to bus 101 for storing information and instructions. Instructions from a computer readable media which are executable by processors 102 or 103 may be stored onto data storage device 107. A data storage device 107 such as a magnetic disk or optical disk and its corresponding disk drive can be coupled to computer system 100.

Computer system 100 can also be coupled via bus 101 to a display device 121, such as a cathode ray tube (CRT), for displaying information to a computer user. An alphanumeric input device 122, including alphanumeric and other keys, is typically coupled to bus 101 for communicating information and command selections to processors 102 and 103. Another type of user input device is cursor control 123, such as a mouse, a trackball, or cursor direction keys for communicating direction information and command selections to processor 102 and for controlling cursor movement on display 121. This input device typically has two degrees of freedom in two axes, a first axis (e.g., x) and a second axis (e.g., y), which allows the device to specify positions in a plane.

Alternatively, other input devices such as a stylus or pen can be used to interact with the display. A displayed object on a computer screen can be selected by using a stylus or pen to touch the displayed object. The computer detects the selection by implementing a touch sensitive screen. Similarly, a light pen and a light sensitive screen can be used for selecting a displayed object. Such devices may thus detect selection position and the selection as a single operation instead of the "point and click" as in a system incorporating a mouse or trackball. Stylus and pen based input devices as well as touch and light sensitive screens are well known in the art. Such a system may also lack a keyboard such as 122 wherein all interface is provided via the stylus as a writing instrument (like a pen) and the written text is interpreted using optical character recognition (OCR)

techniques.

Figure 1 illustrates one embodiment of the present invention where bus 101 is shared between two processors 102 and 103 in the same computer system 100. In order to prevent bus contention, only one of processors 102 or 103 may access bus 101 at one time. Processor 102 is only allowed to access bus 101 during its designated bus mastership state. Similarly, processor 103 is only allowed to access bus 101 during its designated bus mastership state. The bus mastership state of the system is determined by tokens or signals that processors 102 and 103 generate. In one embodiment of the present invention, processors 102 and 103 generate a signal on line 130 each time they gain access to bus 101, relinquish access to bus 101 or wish to gain access to bus 101. In another embodiment of the present invention, the signal generated by one of the processors on line 130 may be a single signal or a plurality of signals. The signals generated by processor 102 are sent to processor 103 via line 130 and the signals generated by processor 103 are sent to processor 102 via line 130. Each processor has a copy of the signals generated by itself and the signals generated by the other processor. Each processor is aware of the current bus mastership state of the system 100.

Figure 2 illustrates an embodiment of the present invention where a processor 102 from a first computer system 250 and a second processor 202 from a second computer system 251 share access to a shared resource 210. Shared resource 210 is a resource which may be accessed by only one of either processor 102 or processor 202 at one time. Shared resource 210 may be, for example, a bus or a memory. Shared resource 210 may be directly coupled to processor 102 and 202 or coupled to processors 102 and 202 via other buses or components. Processor 102 is only allowed to access shared resource 210 during its designated resource mastership state. Processor 202 is only allowed to access shared resource 210 during its designated resource mastership state. The resource mastership state of the systems is determined by tokens or signals that the processors 102 and 202 generate. In one embodiment of the present invention, processors 102 and 202 generate a signal each time they gain access to shared resource 210, relinquish access to shared resource 210 or wish to gain access to shared resource 210. In one embodiment of the present invention, the signal generated by the processor 102 or 210 may be a single signal or a plurality of signals. The signals generated by processor 102 are sent to processor 202 on line 230 and the signals generated by processor 202 are sent to processor 102 on line 230. Each processor has a copy of the signals generated by itself and the other processor. Each processor is aware of the current bus mastership state of the computer systems.

Figure 3 illustrates an embodiment of the present invention as implemented in a mass storage system 300. Mass storage system 300 comprises a first array of storage elements 335 coupled to a hard disk assembly

331 and a second array of storage elements 345 coupled to a hard disk assembly 341. The first and second array of storage elements 335 and 345 are accessed by a host (not shown) via one of the host interface units 304 or 314 and one of buses 301 or 311. Buses 301 and 311 maybe implemented, for example, by a conventional fiber channel interface, a serial storage architecture interface, a small computer system interface (SCSI), a P1394 interface, or other well known interfaces. Hard disk assembly 331 comprises to interface the first array of storage elements 335 with bus 301. Hard disk assembly 331 includes a register 332 which is used for storing data to be read by processors 302 and 312. Hard disk assembly 341 operates to interface the second array of storage elements 345 with bus 311. Hard disk assembly 341 includes a register 342 which is used for storing data to be read by processors 302 and 312.

An environmental service center 325 provides environmental services such as temperature control and power to mass storage system 300. Environmental service center 325 also provides data regarding the environmental services of mass storage system 300. Environmental service center 325 may be implemented by any known circuitry. Processor 302 is coupled to bus 301 and shared bus 320. Processor 302 polls the environmental service center 325 by reading environmental service data from environmental service center 325 via shared bus 320. Processor 302 stores the environmental service data in memory unit 303. Processor 302 operates to monitor the environment of mass storage system 300 and maintains the system's integrity when the environment is out of tolerance range. Similarly, processor 312 is coupled to bus 311 and shared bus 320. Processor 312 polls the environmental service center 325 by reading environmental service data from environmental service center 325 via shared bus 320. Processor 312 stores the environmental service data in memory unit 313. Processor 312 operates to monitor the environment of mass storage system 300 and maintains the system's integrity when the environment is out of tolerance range.

Environmental service data from environmental service center 325 may only be accessed by one of processors 302 and 312 via shared bus 320 at a time. Processor 302 is only allowed to access shared bus 320 during its designated bus mastership state. Processor 312 is only allowed to access shared bus 320 during its designated bus mastership state. The bus mastership state of the system 300 is determined by tokens or signals that processors 302 and 312 generate. In one embodiment of the present invention, the bus mastership state is changed by signals generated by processors 302 or 312 when one of the processors gains access to bus 320, relinquishes access to bus 320, or wishes to gain access to bus 320. In another embodiment of the present invention, the signal generated by each processor 302 or 312 may be a single signal or a plurality of signals. In still another embodiment of the

present invention, a timer 355 in processor 302 and a timer 356 in processor 312 is set each time mastership of shared bus 320 is taken by a new master. The mastership of shared bus 320 is passed each time the timers 355 and 356 time out. The signals generated by processor 302 are sent to processor 312 via line 350 and the signals generated by processor 312 are sent to processor 302 via line 350. Each processor has a copy of the signals generated by itself and the other processor. Each processor 302 or 312 is aware of the current bus mastership state of the system 300.

In one embodiment of the present invention, there are four bus mastership states recognized by processors 302 and 312 of system 300. Figure 4 is a table illustrating the four states. At state 1, processor 302 (Device 1) has mastership of shared bus 320. State 1 occurs when processor 302 generates a 0 signal and processor 312 (Device 2) generates a 0 signal on line 350. At state 2, bus mastership is to be transferred from processor 302 to processor 312. State 2 occurs when processor 302 generates a 1 signal and processor 312 generates a 0 signal on line 350. At state 3, processor 312 has mastership of shared bus 320. State 3 occurs when processor 302 generates a 1 signal and processor 312 generates a 1 signal on line 350. At state 4, bus mastership is to be transferred from processor 312 to processor 302. State 4 occurs when processor 302 generates a 0 signal and processor 312 generates a 1 signal on line 350. Figure 5 is a state diagram illustrating the order in which states 1-4 shown in Figure 4 are executed. It should be appreciated that the number of states, the order in which the states are executed, and the number of signals used to represent the states may change depending on the implementation of the present invention.

Figure 6 illustrates one embodiment of processor 302. Processor 302 includes computation and control unit 610. In one embodiment of the present invention, computation and control unit 610 includes two fiber channel arbitrated loop ports, a block of embedded RAM, a host bus interface, and a processing unit. Computation and control unit 610 operate to poll environmental service data from the environmental service center and to control the environment of computer system 300.

Processor 302 further includes resource accessing unit 620, timer 355, and signal generation unit 631. Resource accessing unit 620 keeps track of the bus mastership states of memory storage system 300 and signals computation and control units 610 to poll the environmental service center 325 when processor 302 receives mastership of shared bus 320. Resource accessing unit 620 receives signals from processor 312 via line 350 which indicate when processor 320 is ready to transition into a next state. Resource accessing unit 620 is coupled to timer 355. Resource accessing unit 620 resets timer 355 when mastership of bus 320 is taken by a new master. After a predetermined amount of time, timer 355 times out. This informs resource

accessing unit 620 that shared bus 320 is to be passed to another master. Resource accessing unit 620 instructs signal generation unit 630 to generate a signal on line 631 to indicate that processor 302 is ready to transition into the next state. The bus mastership state of system 300 is determined by the signals generated by processors 302 and 312. Resource accessing unit 620, timer 355 and signal generation unit 630 may be implemented in hardware, software or a combination of hardware and software. In the embodiment of the invention shown in Figure 6, resource accessing unit 620, timer 355, and signal generation unit 630 are implemented in hardware external to computation and control unit 610. In an alternate embodiment of the present invention, resource accessing unit 620 and signal generation unit 630 are software modules implemented by a set of instructions executed by processor 302. Processor 312 operates similarly to processor 302 and may be implemented by the same components which may be used to implement processor 302.

The present invention allows arbitration of mastership to a shared resource between two devices where neither is master of the other without the use of an external arbiter. In a preferred embodiment of the present invention where the resource accessing unit and signal generation unit is implemented in software, arbitration is achieved without requiring additional power or space from the system.

Although Figure 6 illustrates an embodiment of the present invention where resource accessing unit 620, signal generation unit 630 and timer 355 reside inside processor 302, it should be appreciated that these components may reside in any agent sharing access to a shared resource to arbitrate access to the shared resource.

In one embodiment of the present invention, processor 302 updates the environmental service data in main memory 313 after processor 302 has polled environmental service data from environmental service center 325 and while system 300 is in a state where processor 302 has bus mastership of shared bus 320. In this embodiment of the present invention, processor 312 also updates the environmental service data in main memory 303 after processor 312 has polled environmental service data from environmental service center 325 and while system 300 is in a state where processor 312 has bus mastership of shared bus 320.

Processor 302 updates the environmental service data in main memory 313 through a data exchange. A second line (not shown) is used to communicate mastership of shared bus 320 between processors 302 and 312 during the data exchange in a manner similar to which line 350 communicates mastership of shared bus 320 during data polling. Processor 302 writes environmental service data into registers 332 and 342 of hard disk assembly 332 and 342 when it has mastership of shared bus 320 during data exchange. Processor 312 reads the environmental system data from registers 332 and 342 when it has mastership of shared bus 320 dur-

ing data exchange and stores the data into memory unit 313. Processor 302 continues to write new data into registers 332 and 342 until all the environmental service data in memory unit 303 has been written into registers 332 and 342 and transferred into main memory 313. Processor 312 operates similarly to processor 302 in updating the environmental service data in memory unit 303 when system 300 is in a state where processor 312 has mastership of shared bus 320. In an alternate embodiment of the present invention, a single line and a single set of signals are used by processors 302 and 312 to pass mastership of shared bus 320 during polling and exchange of environmental service data.

In a situation where processor 302 becomes inoperable and fails to generate a signal to processor 312 indicating that it is ready to transition into the next bus mastership state within a predetermined period of time, a timer in processor 312 will time out. This will indicate to processor 312 that processor 302 is inoperable. In response, processor 312 will take exclusive bus mastership of shared bus 320. Similarly, in a situation where processor 312 inoperable and fails to generate a signal to processor 312 indicating that it is ready to transition into the next bus generation state within a predetermined period of time, a timer in processor 302 will time out. This will indicate to processor 302 that processor 312 is inoperable. In response, processor 302 will take exclusive bus mastership of shared bus 320.

Figure 7 is a flow chart illustrating a method for passing mastership of a shared resource between two devices. At step 701, it is determined whether to use the shared resource. This determination may be made by checking a timer which records the time a first device has had access to the resource. After a first predetermined amount of time, the timer times out indicating that it is time for the second device to access the shared resource. If it is not time to use the shared resource, control returns to step 701. If it is time to use the shared resource, control proceeds to step 702.

At step 702, it is determined whether the shared resource is available. This determination may be made by checking a resource accessing unit for the current resource mastership state. If the resource mastership state is one where the first device has mastership, the shared resource is unavailable and control proceeds to step 703. If the shared resource is available, control proceeds to step 705.

At step 703, it is determined whether the first device has had mastership of the shared resource for over a second predetermined amount of time. This determination may be made by checking the timer which records the time when the first device had access to the shared resource. If the first device did not have mastership of the shared resource for over the second predetermined period of time, control returns to step 702. If the first device did have mastership of the shared resource for over the second predetermined amount of time, control proceeds to step 704.

At step 704, exclusive mastership of the shared

resource is given to the second device and the first device is excluded from being considered a possible master of the shared resource in the future.

At step 705, mastership of the shared resource is given to the second device. A signal is generated indicating that the shared resource has been accessed by the second device and the timer is reset.

At step 706, determine whether mastership of the shared resource should be passed to a different device. This determination can be made by checking to see if the timer has timed out past the first predetermined period of time. If the timer has timed out past the first predetermined period of time, it is time to pass mastership of the shared resource to a different resource and control proceeds to step 707. If the timer has not timed out past the first predetermined period of time, control returns to step 706.

At step 707, a signal is generated by the second device indicating that the second device is ready to transition to the next state of resource mastership where it is not the master of the shared resource. Control proceeds to step 701.

In the foregoing specification, the invention has been described with reference to specific embodiments thereof. It will, however, be evident that various modifications and changes may be made thereto without departing from the broader spirit and scope of the invention. The specification and drawings are, accordingly, to be regarded in an illustrative rather than a restrictive sense.

Claims

1. A method for passing bus mastership, comprising:

determining whether a bus is available;
accessing the bus and generating a signal indicating that the bus is being accessed if the bus is available;
starting a timer in response to accessing the bus; and
yielding access to the bus when the timer expires.

2. The method of claim 1 further comprising the step of re-starting the timer after yielding access to the bus.

3. The method of claim 1 further comprising the step of generating a signal indicating that access to the bus has been yielded.

4. The method of claim 1 further comprising the step of determining whether the bus has been accessed longer than a predetermined amount of time if the bus is unavailable and gaining access to the bus if the bus has been accessed longer than the predetermined amount of time.

5. The method of claim 1, wherein determining whether the bus is available comprises the step of checking to see whether a bus agent has generated a signal indicating that it is accessing the bus.

6. A computer-readable medium having stored thereon sequences of instructions, the sequences of instructions including instructions which, when executed by a processor, cause the processor to perform the steps of:

determining whether a bus is available;
accessing the bus and generating a signal indicating that the bus is being accessed if the bus is available;
starting a timer in response to accessing the bus; and
yielding access to the bus when the timer expires.

7. The computer-readable medium of claim 6 further comprising instructions which, when executed by the processor, would cause the processor to perform the step of restarting the timer after yielding access to the bus.

8. The computer-readable medium of claim 6 further comprising instructions which, when executed by the processor, would cause the processor to perform the step of generating a signal indicating that access to the bus has been yielded.

9. The computer-readable medium of claim 6 further comprising instructions which, when executed by the processor, would cause the processor to perform the step of determining whether the bus has been accessed longer than a predetermined amount of time if the bus is unavailable and gaining access to the bus if the bus has been accessed longer than the predetermined amount of time.

10. The computer-readable medium of claim 6, wherein the step of determining whether the bus is available comprises the step of checking to see whether a bus agent has generated a signal indicating that it is accessing the bus.

11. A processor, comprising:

a resource accessing unit allowing the processor to access a resource upon receiving a first signal from a component coupled to the resource and yielding access of the resource to the component upon receiving a second signal from the component.

12. The processor of claim 11 further comprising:

a signal generation unit, coupled to the

resource accessing unit, generating a third signal when the processor has gained access to the resource and generating a fourth signal when the processor has yielded access to the resource.

13. The apparatus of claim 11 further comprising a timer, coupled to the signal generation unit, allocating a time period when the third and fourth signals are generated.

14. The apparatus of claim 11, wherein the component is a second processor.

15. The apparatus of claim 11, wherein the component is a plurality of processors.

16. The apparatus of claim 11, wherein the resource is a bus.

17. The apparatus of claim 11, wherein the resource is a memory.

18. A computer system, comprising

(A) a bus;

(B) a first processor, coupled to the bus, having

(1) a first signal generation unit generating a first signal when the first processor has gained access to the bus and generating a second signal when the first processor has yielded access to the bus; and

(2) a first bus accessing unit allowing the first processor to access the bus upon receiving a third signal and yielding access to the bus upon receiving a fourth signal;

(C) a second processor, coupled to the bus and the first processor, having

(1) a second signal generation unit generating the fourth signal when the second processor has gained access to the bus and generating the third signal when the second processor has yielded access to the bus; and

(2) a second bus accessing unit allowing the second processor to access the bus upon receiving the second signal and yielding access to the bus upon receiving the first signal.

19. The computer system of claim 18 further comprising an array of storage devices coupled to the first and second processors.

20. The computer system of claim 18 further comprising an environmental service center coupled to the

bus.

21. A bus arbitrating apparatus residing in a bus agent configured to communicate with a processor based system including a memory, bus, and display, comprising:

a resource accessing unit allowing the bus agent to access the bus upon receiving a first signal from a component coupled to the bus and yielding access of the bus to the component upon receiving a second signal from the component.

22. The bus arbitrating apparatus of claim 21, further comprising:

a signal generation unit, coupled to the resource accessing unit, generating a third signal when the bus agent has gained access to the resource and generating a fourth signal when the bus agent has yielded access to the resource.

23. A system for arbitrating a bus between a first bus agent and a second bus agent comprising:

a first signal generation unit generating a first signal when the first bus agent has gained access to the bus and generating a second signal when the first bus agent has yielded access to the bus;

a first bus accessing unit allowing the first bus agent to access the bus upon receiving a third signal and yielding access to the bus upon receiving a fourth signal, wherein the first signal generation unit and the first bus accessing unit reside inside the first bus agent;

a second signal generation unit generating the fourth signal when the second bus agent has gained access to the bus and generating the third signal when the second bus agent has yielded access to the bus; and

a second bus accessing unit allowing the second bus agent to access the bus upon receiving the second signal and yielding access to the bus upon receiving the first signal, wherein the second signal generation unit and second bus accessing unit reside inside the second bus agent.

24. The system of claim 23 further comprising an array of storage devices coupled to the first and second bus agents.

25. The system of claim 23 further comprising an environmental service center coupled to the bus.

FIG. 1

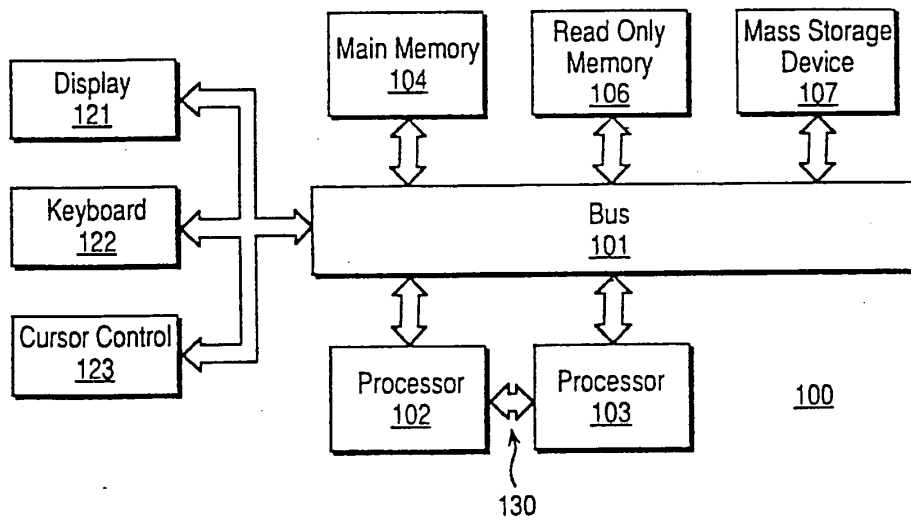

FIG. 2

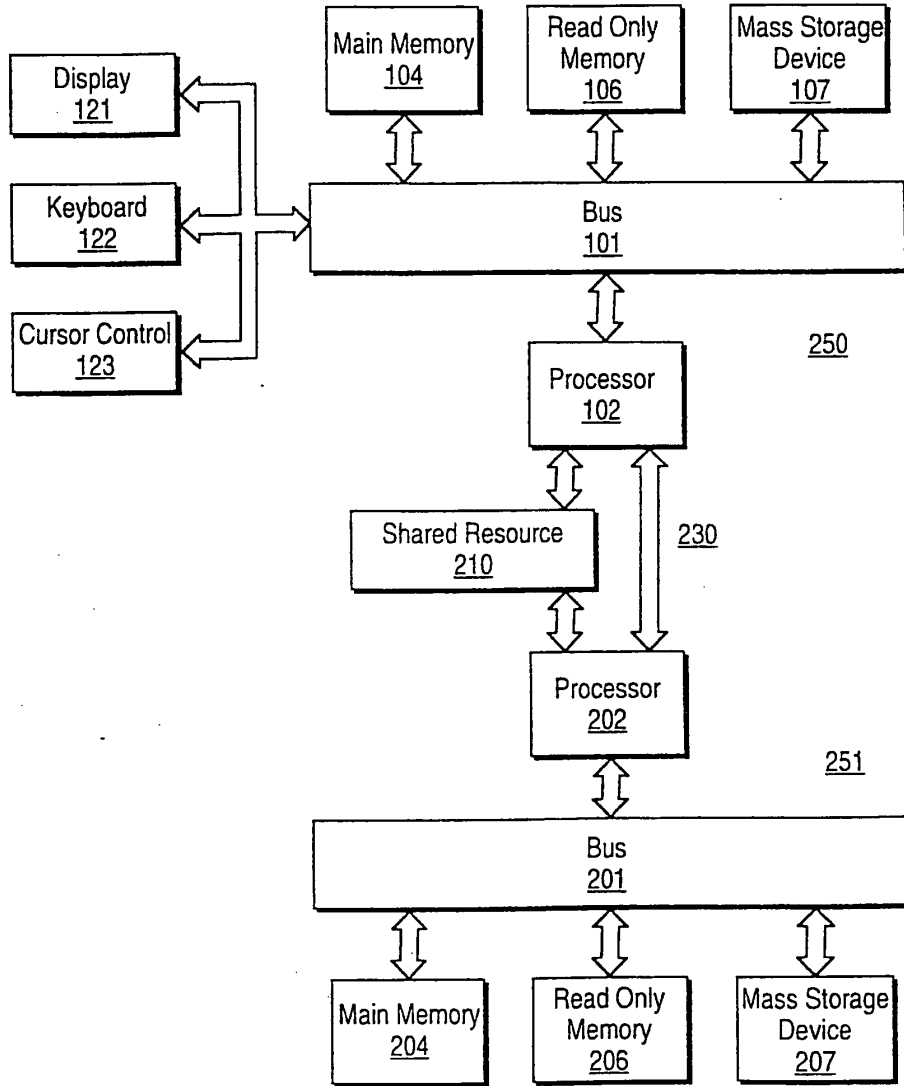

FIG. 3

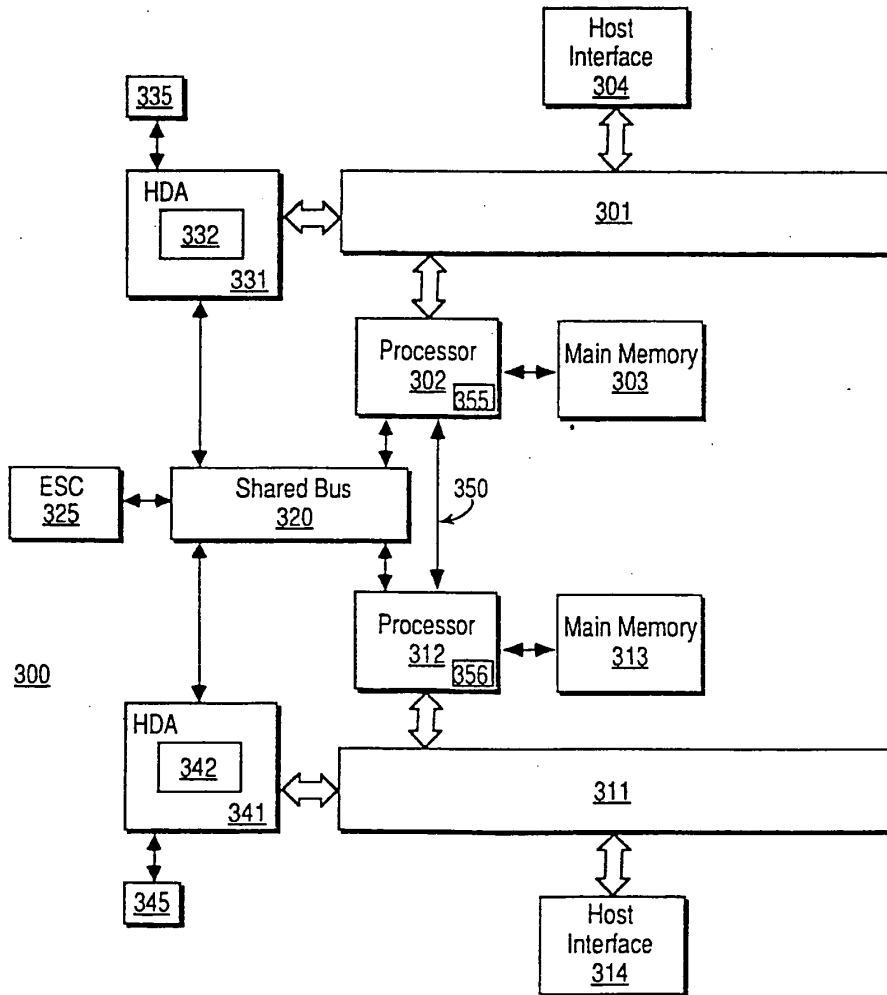

FIG. 4

State	Device 1	Device 2	Mastership
1	0	0	Device 1 is master
2	1	0	Mastership is to be passed from Device 1 to Device 2
3	1	1	Device 2 is master
4	0	1	Mastership is to be passed from Device 2 to Device 1

FIG. 5

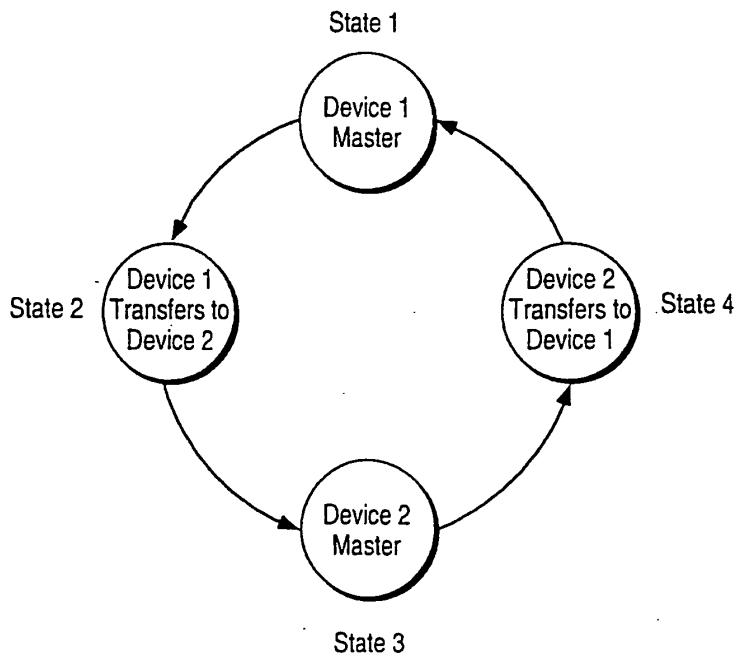

FIG. 6

302

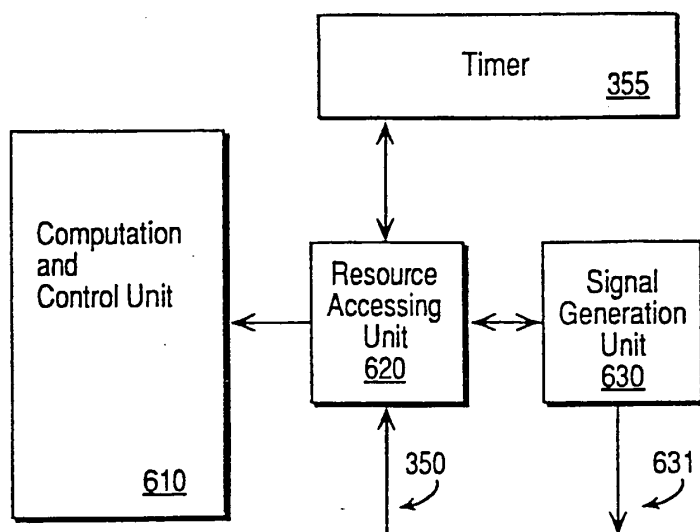
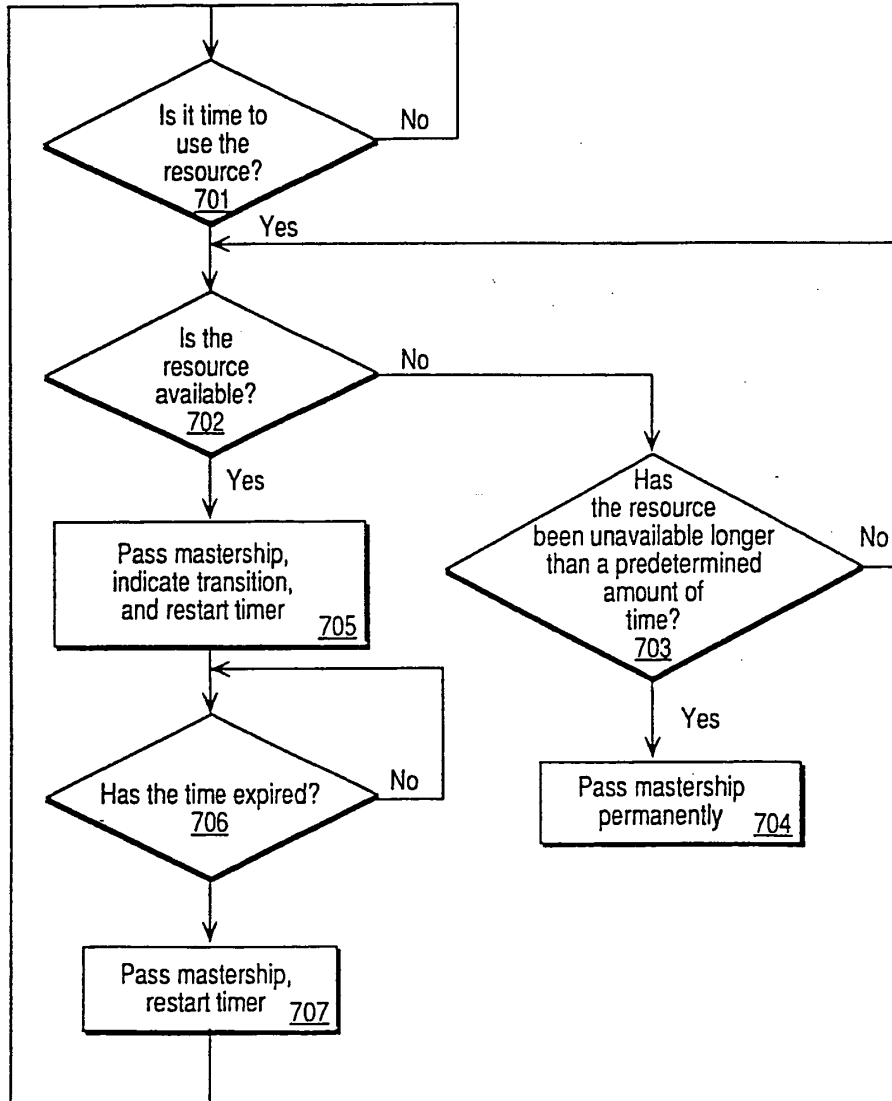

FIG. 7



85

(19)  **Europäisches Patentamt**
European Patent Office
Office européen des brevets



(11) **EP 0 827 059 A2**

(12) **EUROPEAN PATENT APPLICATION**

(43) Date of publication: **04.03.1998 Bulletin 1998/10** (51) Int. Cl.⁶: **G06F 1/00, G06F 3/06**

(21) Application number: **97114612.1**

(22) Date of filing: **22.08.1997**

<p>(84) Designated Contracting States: AT BE CH DE DK ES FI FR GB GR IE IT LI LU MC NL PT SE Designated Extension States: AL LT LV RO SI</p> <p>(30) Priority: 30.08.1996 JP 230895/96</p> <p>(71) Applicant: NEC Corporation Minato-ku, Tokyo 108-01 (JP)</p>	<p>(72) Inventors: • Kikuchi, Yoshihide Minato-ku, Tokyo 108-01 (JP) • Akagi, Masanobu Minato-ku, Tokyo 108-01 (JP)</p> <p>(74) Representative: von Samson-Himmelstjerna, Friedrich R., Dipl.-Phys. SAMSON & PARTNER Widenmayerstrasse 5 80538 München (DE)</p>
-------------------------------------------------------------------------------------------------------------------------------------------------------------------------------------------------------------------------------------------------------------------------------------------------------------------------------	-------------------------------------------------------------------------------------------------------------------------------------------------------------------------------------------------------------------------------------------------------------------------------------------------------------------------------------------------------------------------------------

(54) **Disk apparatus**

(57) The apparatus enables access authorization to be assigned solely to specific host devices. A control device (106) comprises: an address registration unit (104), in which the host address of each host device has been registered for authorizing access, a command interpretation and execution unit (102) which on receipt of a command from a host device via a host device interface outputs the host address of the host device based on the command, and an address verification unit (103) for verifying the host address output from a command

interpretation and execution unit (102) against the host address registered in the address registration unit (104), as well as determining whether or not the particular host device has access authorization. The command interpretation and execution unit (102) incorporates an authorization pending function, so that on receipt of a command from a host device, the command is interpreted and executed only after access is authorized by the address verification unit (103).

FIG.1

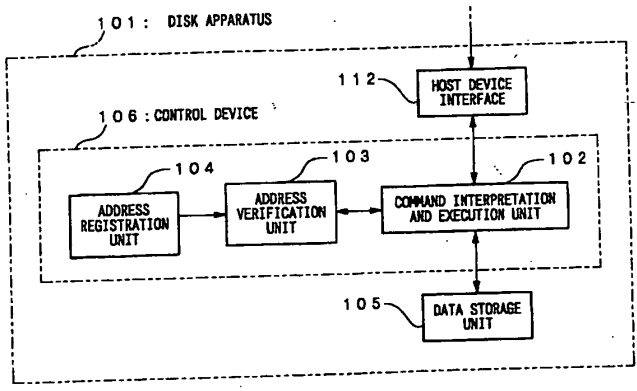

EP 0 827 059 A2

Description

BACKGROUND OF THE INVENTION

Field of the Invention

The present invention relates to a disk apparatus, and in particular to a disk apparatus which can be accessed by a plurality of host devices.

Description of the Related Art

With conventional disk apparatus, each host controls the disk or disk array directly, and disk security is controlled by the host device to which the disk is connected. File sharing with this type of file server client system is disclosed for example in Japanese Patent Application, First Publication No. Hei-4-58349.

A block diagram showing the configuration of a conventional disk apparatus is shown in Figure 6. A conventional disk apparatus 201 comprises a command interpretation and execution unit 202 which interprets commands from a host device as well as executing those commands, and a data storage unit 203 in which data is stored. The command interpretation and execution unit 202, in the case of a read command for example, interprets the command, and recognizing the command as a read command directs the data storage unit 203 to read. The data storage unit 203 reads the stored data based on the read directions from the command interpretation and execution unit 202, and then transfers the data to the host device.

Common ways of connecting the host device and the disk apparatus include a SCSI (Small Computer System Interface) and Fibre Channel. Consequently, the command interpretation and execution unit 202 interprets commands from the SCSI or Fibre Channel and then outputs commands such as read and/or write, to the disk data storage unit 203.

With this type of conventional disk apparatus, usually a single host device is connected to the disk apparatus. Furthermore, even in those cases where a plurality of host devices are connected to a common disk interface, with current technology it is possible for any of the host devices to access the disk.

With advances in technology relating to the interface between the host device and the disk apparatus however, it has become feasible to connect a plurality of host devices. Using Fibre Channel, it is possible for example to use loops (FC-AL) to connect together more than 100 devices including both host devices and disk apparatus. Moreover, if switching fabric is employed the number of devices which can be connected together increases even further. Utilizing the high speed of interfaces, it is also possible to connect a plurality of host devices and disk apparatus to a single interface. With conventional disk apparatus, a problem arises that in the case where a single disk is able to be accessed by

a plurality of hosts devices, access authorization can not be restricted to specific host devices.

Furthermore, with the move to large volume disk apparatus, it is possible to consider partitioning a single disk and then having each host use a different partition, but with conventional disk apparatus it has not been possible, while using a single interface, to identify a host device and then have each host device use a different partition.

SUMMARY OF THE INVENTION

It is an object of the present invention to improve the deficiencies inherent in the conventional devices discussed above, and in particular to provide a disk apparatus in which each host device can be treated differently, so that for example access authorization can be assigned solely to specific host devices, or furthermore, each host device can gain access to a different partition while using the same interface.

A first apparatus according to the present invention comprises: a host device interface for sending and receiving data to and from a plurality of host devices, a data storage device for storing data to be sent to a host device, and a control device for controlling the writing of data to, and the reading of data from, the data storage device.

The control device comprises an address registration unit, in which the host address of each host device has been registered in advance, for the purpose of authorizing access, a command interpretation and execution unit which on receipt of a command from a host device via the host device interface outputs the host address of the host device based on the command, and an address verification unit for verifying the host address output from the command interpretation and execution unit against the host address registered in the address registration unit, and for determining whether or not the particular host device has access authorization. The command interpretation and execution unit is configured to include an authorization pending function, so that on receipt of a command from a host device, the command is interpreted and executed only after access is authorized by the address verification unit.

With this first apparatus, the host address is extracted from the command sent from a host device and verified against those host addresses registered in the address registration unit for the purpose of determining access authorization. As a result, if access is authorized, the disk apparatus accepts the command which has been sent and disk read/write functions are performed. In this way, only authorized host devices gain access to the data storage unit.

As a second apparatus according to the present invention a construction is adopted where, in addition to the items which characterize the first apparatus, a host information storage unit in which information about the hosts such as host names and passwords is stored, is

incorporated into the address registration unit, and a host check unit which, on receipt of host information from a host, determines whether or not that particular host has access authorization based on the host information received from the host and the host information stored in the host information storage unit, is incorporated into the command interpretation and execution unit, and this host check unit incorporates an address registration function which registers the access authorization based on the host information, and the host address determined for the host device, in the address registration unit.

With this second apparatus, when a host device logs in to the disk apparatus seeking authorization to use the disk, the address is registered in the address registration unit, and subsequently, the host address is extracted from any commands sent from the host device and verified against the host address registered in the address registration unit, and in those cases where access is authorized the command interpretation and execution unit transmits the command from the host device to the data storage unit and executes the command. In this way, any alterations in host address can be easily accommodated.

With a third apparatus, a construction is adopted where in addition to the items which characterize the second apparatus, the host check unit incorporates a startup setting function which requests host information from a plurality of host devices when the control device is activated.

With this third apparatus, host information relating to access authorization is not stored internally beforehand, but rather is sent from the host devices which control the disk at the point of disk startup. Consequently, the amount of non volatile memory set aside for data storage can be reduced.

As a fourth apparatus according to the present invention a construction is adopted where, in addition to the items which characterize the first apparatus, the control device comprises: an offset information generation unit, which on the basis of a host address output from the command interpretation and execution unit generates offset information for the disk partition for that particular host device, and an actual partition address generation unit which on the basis of the address for reading and writing to the disk apparatus, and the offset information, generates an actual disk partition address and then outputs that actual partition address to the command interpretation and execution unit.

With this fourth apparatus, the disk capacity is partitioned amongst the various host devices, and the various host addresses and the offset information for each partition are coordinated beforehand. When a command is received from a host device, the command interpretation and execution unit extracts the host address from the command and sends it to the offset information generation unit. The offset information generation unit then uses a correlation chart of host devices

and offset information which has been stored in advance, and generates offset information which corresponds to the particular host device and sends this information to the actual partition address generation unit. The actual partition address generation unit combines the theoretical disk address included in the command from the host device and the offset information, and generates an actual disk partition address. In this way, the disk partition corresponding to the host device from which the command was sent is accessed.

BRIEF DESCRIPTION OF THE DRAWINGS

Figure 1 is a block diagram showing the configuration of a first embodiment of the present invention; Figure 2 is an explanatory diagram displaying a phase transition state of a SCSI bus;

Figure 3 is a block diagram showing an example configuration of hardware resources of a disk apparatus according to the first embodiment shown in Figure 1;

Figure 4 is a block diagram showing the configuration of a second embodiment of the present invention;

Figure 5 is a block diagram showing the configuration of a third embodiment of the present invention; and

Figure 6 is a block diagram showing a configuration based on current technology.

DESCRIPTION OF THE PREFERRED EMBODIMENTS

Next is a description of the preferred embodiments of the present invention, with reference to the drawings.

First embodiment

A block diagram showing the configuration of a disk apparatus according to a first embodiment of the present invention is shown in Figure 1. As is shown in Figure 1, a disk apparatus 101 comprises a host device interface 112 for sending and receiving data to and from a plurality of host devices, a data storage device (data storage unit) 105 for storing data to be sent to a host device, and a control device 106 for controlling the writing of data to, and the reading of data from, the data storage device 105.

The control device 106 comprises: an address registration unit 104, in which the host address of each host device has been registered for authorizing access, a command interpretation and execution unit 102 which on receipt of a command from a host device via the host device interface outputs the host address of the host device based on the command, and an address verification unit 103 for verifying the host address output from the command interpretation and execution unit 102 against the host address registered in the address reg-

istration unit 104, and for determining whether or not the particular host device has access authorization.

The command interpretation and execution unit 102 incorporates an authorization pending function, so that on receipt of a command from a host device, the command is interpreted and executed only after access is authorized by the address verification unit 103.

The command interpretation and execution unit 102 first receives a command from a host device, extracts the host address from the command and outputs it to the address verification unit 103. The address verification unit 103 reads the host addresses stored in the address registration unit 104 for the purpose of determining access authorization and verifies the host address sent from the command interpretation and execution unit 102. The access authorization information generated as a result of this verification process is then relayed back to the command interpretation and execution unit 102 by the address verification unit 103.

In those cases where access is authorized, the command interpretation and execution unit 102 sends the command received from the host device to the data storage unit 105, and the disk apparatus command, such as a data read/write command, is carried out in the same manner as for conventional disks.

The technique for determining access authorization could for example involve the registration of the host addresses of those host devices for which access is authorized in the address registration unit 104 and comparison of these address with the host address extracted from each command, with authorization being given in the case of a matching address. Alternatively, the host addresses of those host devices for which access is not authorized could be registered in the address registration unit 104, and authorization given if the host address extracted from the command did not match any of the registered addresses.

With the above example it was assumed that the host address was imbedded in the command, but in practice, the host address can sometimes be identified in exchanges prior to, or after the command. An example is presented in way of an explanation below.

For example in the case of a SCSI, the bus phase can be roughly divided up as shown in Figure 2. With a SCSI generally the host device interface is the initiator and the disk apparatus interface the target. When sending a command to the disk apparatus, the host device interface, the initiator, secures the bus in the arbitration phase, selects the disk apparatus in the selection phase, and then enters the information transfer phase for sending the command or data.

Within this series of phases, the initiator outputs its own ID and the ID of the target it is aiming to select in the selection phase. The specified disk apparatus, namely the target, on confirming it has been selected corresponds by switching the bus BSY signal to "true". At this point, the target samples the data bus and identifies the ID of the initiator.

In this way, the disk apparatus is able to ascertain the SCSI ID, namely the host address, of the other device. Further details are given in "Open design No. 1" (Published by CQ, 1994), pages 4 to 19.

In the case of a Fibre Channel, because communication is serial, the host address is recorded within the frame and so once again the disk apparatus is able to ascertain the host address of the other device.

Furthermore nowadays, in addition to those mentioned above, there are other protocols (such as IP (Internet Protocol)) which although not widely used as disk interfaces, do include a host address which becomes the transmission source.

An example configuration of the above embodiment which uses a general purpose CPU (central processing unit) is shown in Figure 3. A disk apparatus 101 comprises a CPU 106 which performs the centralized function of controlling reading and writing. The CPU 106 is connected to various circuit devices via a bus 107. Of these devices, a ROM (read only memory) 108 is memory solely for reading, and stores various programs and fixed data.

A RAM (random access memory) 109 is memory which is used, as required, for temporarily storing data during execution of a program.

A non volatile memory 110 is memory which can be written to by the CPU, and the content of which is saved when the power is turned off. A disk interface 111 is an interface for exchanging data and commands between the CPU and a data storage unit 105 which will be either a disk or some other storage medium.

A host device interface 112 is an interface for exchanging commands and data from a host device with the disk apparatus 101. In the case of a disk array, a SCSI is used for both the host device interface 112 and for the disk interface 111, but generally it is acceptable for the host device interface 112 and the disk interface 111 to be of different types.

For example, a Fibre Channel could be used for the host device interface 112 and a SCSI used for the disk interface 111. In small apparatus the disk storage medium itself is used as the data storage unit 105, but in large apparatus such as disk arrays the disk drive itself can be used as the data storage unit 105.

Next is a description of the use of the hardware resources shown in Figure 3 to bring to realization the function blocks of Figure 1. The command interpretation and execution unit 102 of Figure 1 is configured using the CPU 106, the bus 107, the ROM 108, the RAM 109, the disk interface 111 and the host device interface 112 of Figure 3. Similarly, the address verification unit 103 is configured using the CPU 106, the bus 107, the ROM 108, and the RAM 109.

The address registration unit 104 can be configured using the non volatile memory 110. Moreover, a read/write capable disk drive can be used as the data storage unit 105. In those instances where a disk drive with a SCSI interface is used as the data storage unit,

the commands which can be sent from the command interpretation and execution unit 102 to the data storage unit 105 are not limited to just read and write commands for data, but can also indicate commands in general retained by the SCSI interface. Furthermore, the disk drive can comprise any form which allows data storage, and can therefore be configured from memory with a power backup function or from non volatile memory.

Next is a description of the operation of a disk apparatus configured as shown in Figure 3. First, host addresses are stored in advance in the non volatile memory 110. The stored host addresses can be rewritten by the CPU 106, but will not be erased when the power is switched off. Consequently, when power is supplied to the disk apparatus 101, the host addresses which have been previously stored are able to be read out.

The command interpretation and execution unit 102 of Figure 1 receives commands from the host devices at the host device interface 112 and stores them temporarily in the RAM 109. The CPU 106 uses the programs stored in the ROM 108 for interpreting a command from a host device and extracting the host address. The thus extracted host address is then verified against the host addresses stored in the non volatile memory 110 by the CPU 106. In the method where the host addresses for those devices which are authorized for access are stored in the non volatile memory 110, access is authorized when the host address extracted from the command from the host device matches one of the host addresses stored in advance in the non volatile memory.

In those cases where access is authorized, the CPU 106 sends a command to the disk interface 111 in order to execute the command from the host device, which had been temporarily stored in the RAM 109. The disk interface 111 executes the command by sending it to the data storage unit 105. In those cases where information needs to be relayed to the host device as a result of the command being executed, the disk interface informs the CPU 106 that it has received a result.

On receiving this notification the CPU 106 receives the result from the disk interface 111, stores it temporarily in the RAM 109, and then transfers the result to the host device interface. In this way, commands from a host device are first judged as to whether access is possible, and then following execution, any result of the execution is returned to the host device.

With the above example, the host address stored temporarily in the RAM 109 and the access authorization determining host addresses stored in the non volatile memory 110 were compared, but in some cases the reading of non volatile memory is time consuming, and so it is possible to imagine a technique where on startup of the disk apparatus the access authorization determining host addresses stored in the non volatile memory 110 are transferred to the RAM 109.

Furthermore as with the invention of the first appa-

ratus, it is possible to imagine a technique where on startup of the disk apparatus the access authorization determining host addresses are transferred from the host device which controls the disk, and then stored in the RAM 109. With this technique, the amount of non volatile memory 110 can be greatly reduced.

Second embodiment

A block diagram showing the configuration of a disk apparatus according to a second embodiment of the present invention is shown in Figure 4. This is an embodiment which allows the setting of the host address afterwards. This embodiment will be explained in terms of the login operation from a host device to obtain authorization for using the disk apparatus, and the normal access operation.

First, in the login operation, the host information sent from a host device is used to determine whether that particular host device should be authorized. A disk apparatus 113 of this embodiment comprises a command interpretation and execution unit 114 for interpreting and executing commands from host devices. The command interpretation and execution unit 114 receives a command from a host device and extracts the necessary host information required to authorize usage of the disk apparatus as well as the host address accompanying that host information, and sends it all to a host check unit 115.

In the host check unit 115, this information is verified against access authorization determining host information which has been stored in advance in a host information storage unit 116. Examples of host information include the host device name, and a password. In those cases where the comparison results in a match, the host address sent from the command interpretation and execution unit 114 is registered in an address registration unit 118 as an access authorization determining address.

Once the host address has been registered in the address registration unit 118 in this way, the remaining operation is the same as for the first embodiment. Upon receiving a command from a host device the command interpretation and execution unit 114 extracts the host address from the command. It then sends this address to an address verification unit 117 and the address verification unit 117 verifies the address against the access authorization determining host addresses stored in the address registration unit 118 and then relays an access authorized or access denied message back to the command interpretation and execution unit 114. In the case where access is authorized, the command interpretation and execution unit 114 sends a command to the data storage unit 105 in order to execute the command.

With the second embodiment, the actual circuit configuration could take the form shown in Figure 3, as was the case with the first embodiment. The command interpretation and execution unit 114 of Figure 4 could

then be configured comprising the CPU 106, the bus 107, the ROM 108, the RAM 109, the disk interface 111, and the host device interface 112 of Figure 3. Similarly, the host check unit 115 and the address verification unit 117 can be configured comprising the CPU 106, the bus 107, the ROM 108, and the RAM 109. Furthermore, the host information unit 116 and the address registration unit 104 can be configured using the non volatile memory 110.

Third embodiment

A block diagram showing the configuration of a disk apparatus according to a third embodiment of the present invention is shown in Figure 5. A disk apparatus 119 of this embodiment comprises a command interpretation and execution unit 120 for interpreting and executing commands from a host device. The command interpretation and execution unit 120 extracts a host address from any disk read/write command sent from a host device and outputs it to an address offset information conversion unit 121, and also outputs a disk partition address extracted from the read/write command to an actual partition address conversion unit 122.

The technique used by the command interpretation and execution unit 120 for extracting a host address is as was outlined for the first embodiment. The host address output from the command interpretation and execution unit 120 is input into the address offset information conversion unit 121. Offset information which indicates a disk partition corresponding to each host device, has been stored in advance in the address offset information conversion unit 121, and the host address input from the command interpretation and execution unit 120 is converted to this offset information.

The actual partition address conversion unit 122 combines the disk partition address output from the command interpretation and execution unit 120 with the offset information output from the address offset information conversion unit 121, and generates an actual disk partition address which it then outputs to the command interpretation and execution unit 120. The command interpretation and execution unit 120 outputs a read/write command to the data storage unit 105 based on the actual disk partition address. The data storage unit 105 executes the command output from the actual partition address conversion unit 122 by, for example, reading out data to the host device, or receiving and storing data from the host device.

The present invention is configured and functions in the manner outlined above, with the invention of the first apparatus enabling the provision of a highly secure and advanced disk apparatus of a type not currently available, wherein determination of access authorization for a host device is based on the host address imbedded in the command sent from that particular host device, thus enabling commands to be accepted only from specified

host devices.

With the invention of the second apparatus, the information registered in advance in the disk apparatus by the user is not host addresses, but rather host information. Each host address is registered prior to that host device using the disk apparatus, so that once registered, subsequent recognition of the host device can be based on the host address imbedded in normal commands. Therefore procedures can be vastly simplified in comparison with the technique where host information is exchanged each time the disk apparatus is accessed. Furthermore, because the information registered in advance in the disk apparatus does not include host addresses, even if the interface configuration or address is changed there is little effect, allowing high security to be maintained.

With the invention of the third apparatus, following disk startup the host addresses relating to access authorization are received from the host device which controls the disk apparatus, and stored internally. This offers the advantage that complicated programming relating to host address registration does not need to be provided on the disk.

With the invention of the fourth apparatus, the disk apparatus is able to identify a host device from the host address imbedded within the command sent from the host device. Moreover because a partition offset information value is stored for each host device, the disk apparatus is able to allocate a different disk partition to each host device. Consequently, a single disk apparatus can essentially appear as a different disk to each host device, enabling the efficient usage of modern large volume disk apparatus.

Claims

1. A disk apparatus comprising, a host device interface (112) for sending and receiving data to and from a plurality of host devices, data storage means (105) for storing data to be sent to said host devices, and control means (106) for controlling the writing of data to, and the reading of data from, said data storage means (105), characterized in that said control device (106) comprises: an address registration unit (104; 118), in which the host address of each host device has been registered in advance, for the purpose of authorizing access, a command interpretation and execution unit (102; 114; 120) which on receipt of a command from a host device via said host device interface (112) outputs the host address of said host device based on said command, and an address verification unit (103) for verifying the host address output from said command interpretation and execution unit (102; 114) against the host address registered in said address registration unit (104; 118), and for determining whether or not the particular host device has access authorization, and said command interpre-

tation and execution unit (102; 114; 120) incorporates an authorization pending function, so that on receipt of a command from a host device, the command is interpreted and executed only after access is authorized by said address verification unit (103). 5

2. A disk apparatus according to claim 1, wherein a host information storage unit (116) in which information about the hosts such as host names and passwords is stored, is incorporated into said address registration unit (104; 118), and a host check unit (115) which, on receipt of host information from a host, determines whether or not that particular host has access authorization based on the host information received from the host and the host information stored in said host information storage unit (116), is incorporated into said command interpretation and execution unit (102; 114; 120), and said host check unit (115) incorporates an address registration function which registers the access authorization based on the host information, and the host address determined for the host device, in said address registration unit (104; 118). 10
3. A disk apparatus according to claim 2, wherein said host check unit (115) incorporates a startup setting function which requests host information from a plurality of host devices when said control means (106) is activated. 15
4. A disk apparatus according to claim 2, wherein said control means (106) comprises: an offset information generation unit (121), which on the basis of a host address output from said command interpretation and execution unit (102; 114; 120) generates offset information for the disk partition for that particular host device, and an actual partition address generation unit (122) which on the basis of the address for reading and writing to the disk apparatus, and the offset information, generates an actual disk partition address and then outputs that actual partition address to said command interpretation and execution unit (102; 114; 120). 20
5. A disk apparatus according to claim 1, wherein said command interpretation and execution unit (102; 114; 120) extracts said host address from said command received from said host device. 25

30

35

40

45

50

55

7

FIG.1

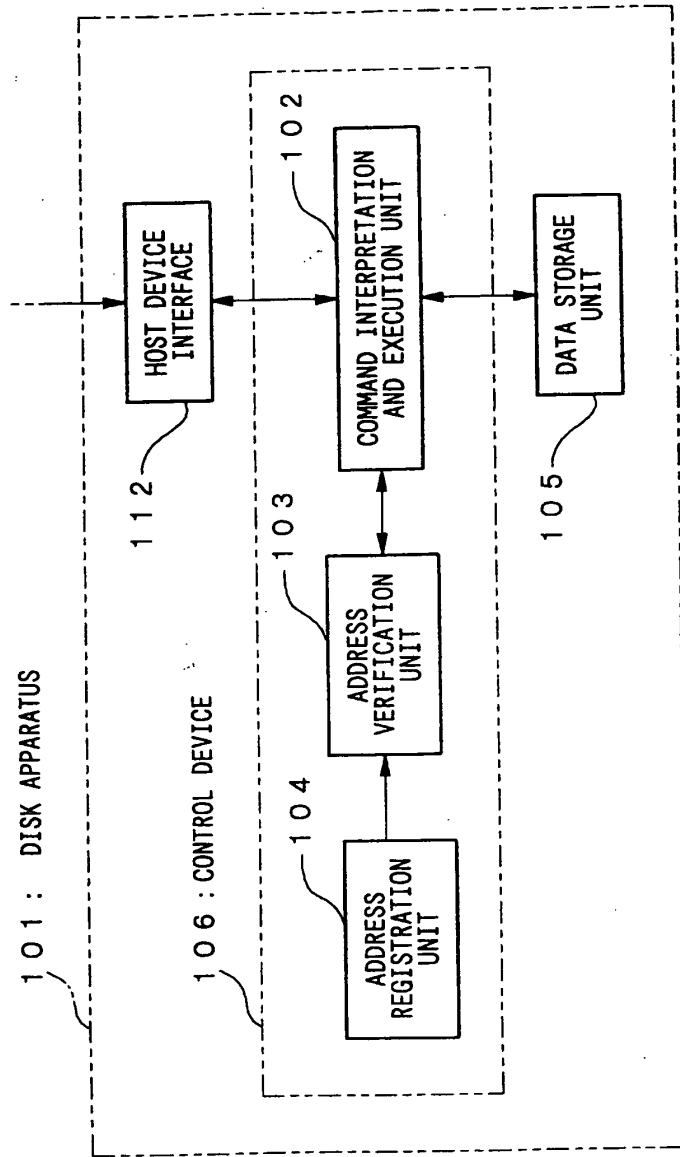

FIG.2

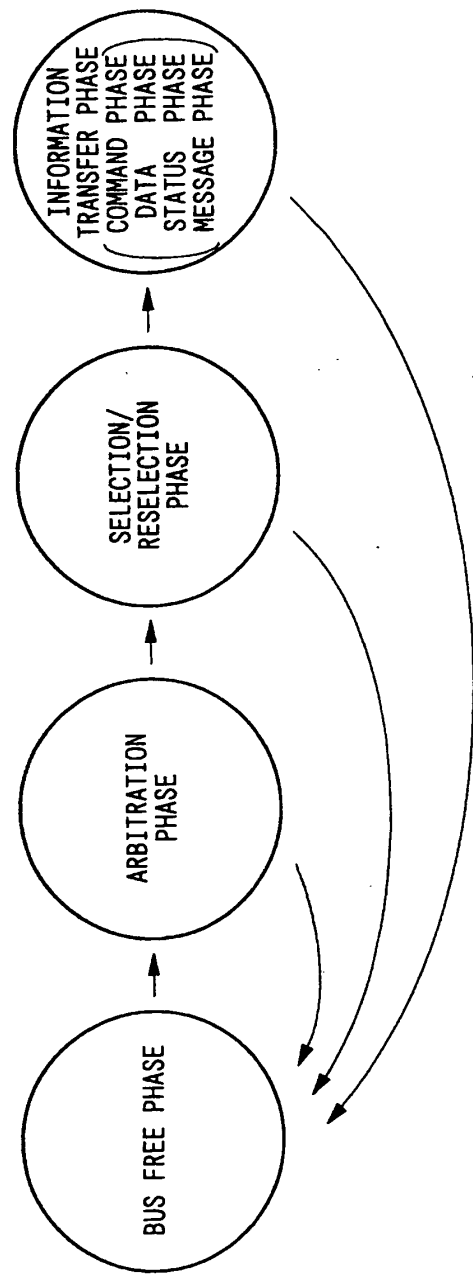

FIG.3

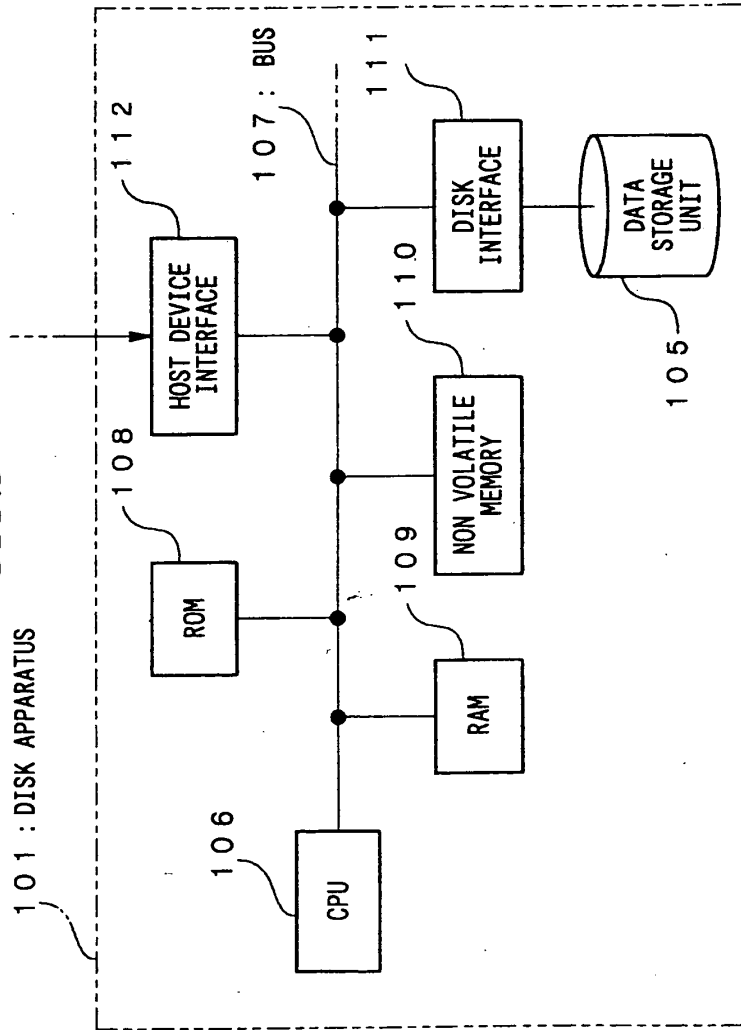

FIG.4

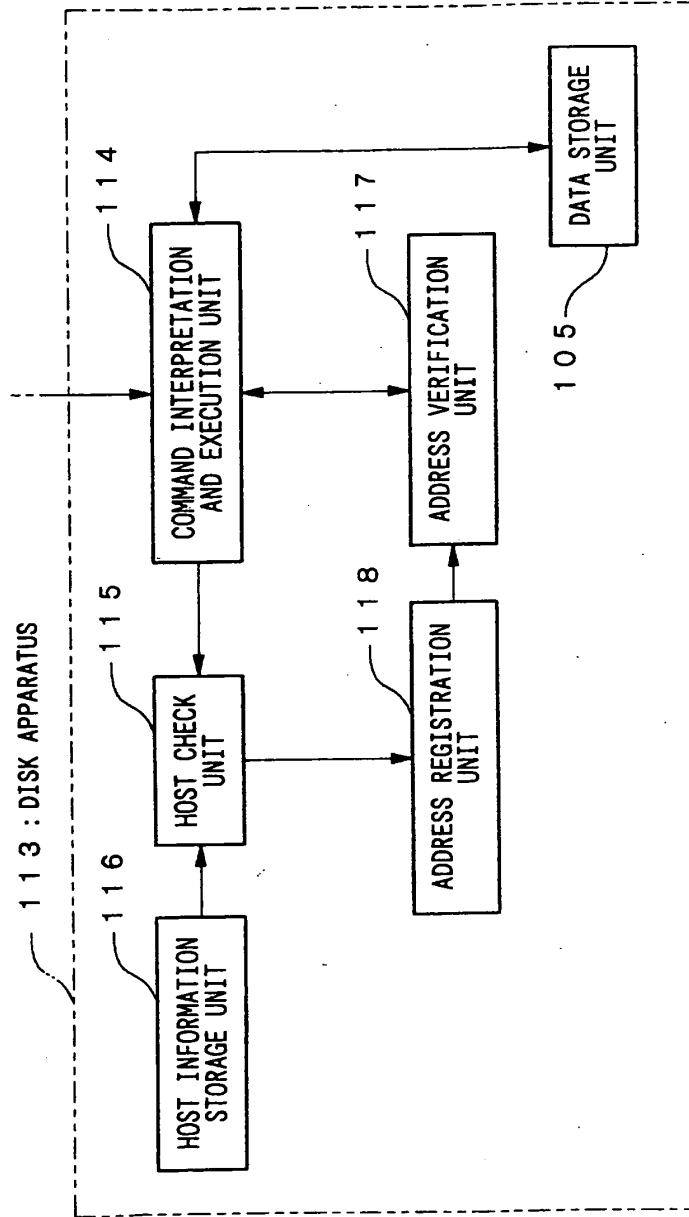

FIG.5

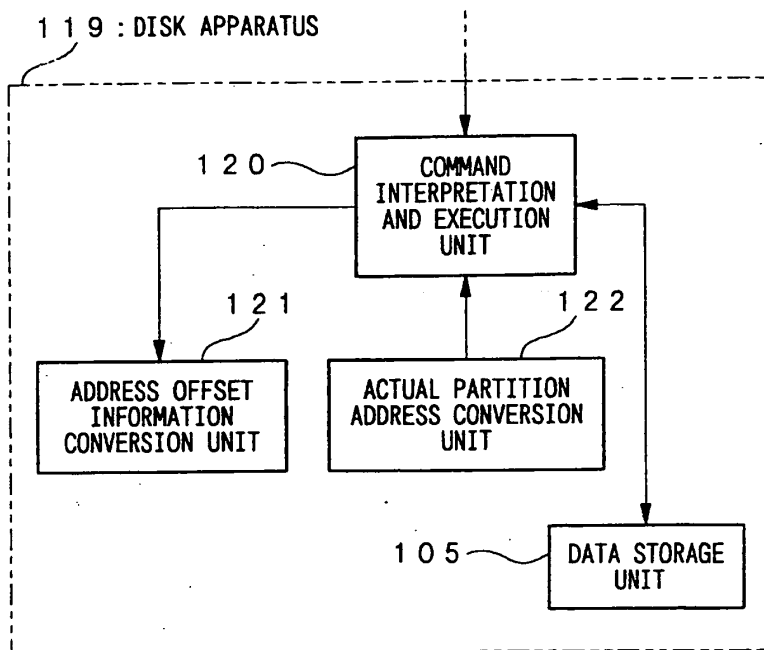
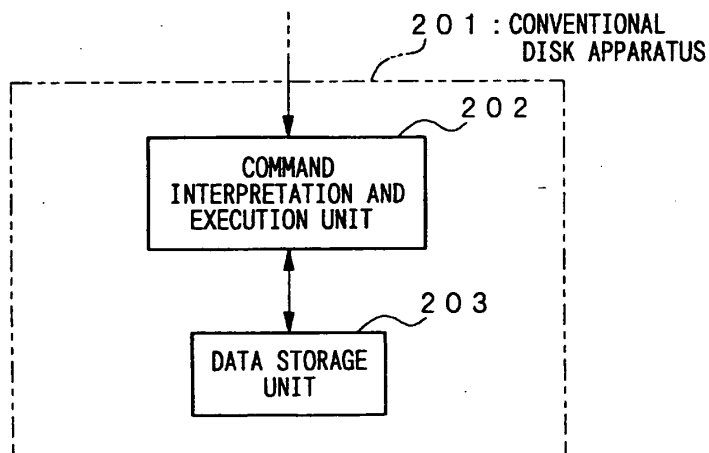

FIG.6



86

PCT

WORLD INTELLECTUAL PROPERTY ORGANIZATION
International Bureau



INTERNATIONAL APPLICATION PUBLISHED UNDER THE PATENT COOPERATION TREATY (PCT)

(51) International Patent Classification 6 : G06F 13/00	A1	(11) International Publication Number: WO 99/34297
(21) International Application Number: PCT/US98/27689		(43) International Publication Date: 8 July 1999 (08.07.99)
(22) International Filing Date: 28 December 1998 (28.12.98)		(81) Designated States: CA, JP, European patent (AT, BE, CH, CY, DE, DK, ES, FI, FR, GB, GR, IE, IT, LU, MC, NL, PT, SE).
(30) Priority Data: 09/001,799 31 December 1997 (31.12.97) US		Published <i>With international search report.</i>
(71) Applicant: CROSSROADS SYSTEMS, INC. [US/US]; Suite II-300, 9390 Research Boulevard, Austin, TX 78759 (US).		
(72) Inventors: HOESE, Geoffrey, B.; 1904 Ann Arbor Avenue, Austin, TX 78704 (US). RUSSELL, Jeffrey, T.; 205 Kariba Cove, Cibolo, TX 78108 (US).		
(74) Agent: HULSEY, William, R., III; Gray Cary Ware & Freidenrich LLP, Suite 1440, 100 Congress Avenue, Austin, TX 78701 (US).		

(54) Title: STORAGE ROUTER AND METHOD FOR PROVIDING VIRTUAL LOCAL STORAGE

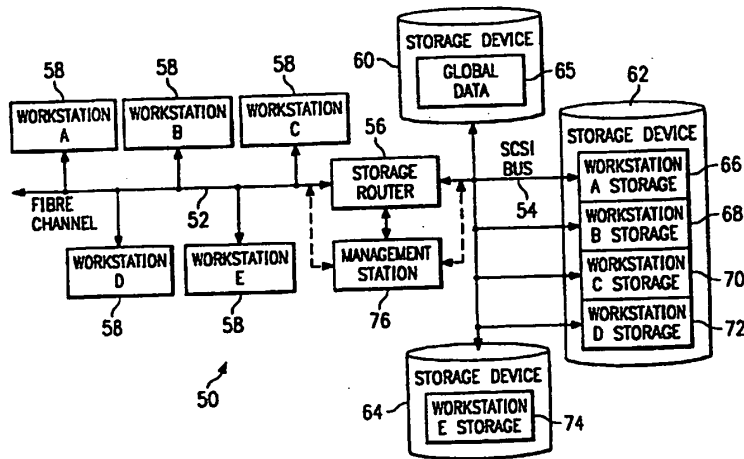

(57) Abstract

A storage router (56) and storage network (50) provide virtual local storage on remote SCSI storage devices (60, 62, 64) to Fibre Channel devices. A plurality of Fibre Channel devices, such as workstations (58), are connected to a Fibre Channel transport medium (52), and a plurality of SCSI storage devices (60, 62, 64) are connected to a SCSI bus transport medium (54). The storage router (56) interfaces between the Fibre Channel transport medium (52) and the SCSI bus transport medium (54). The storage router (56) maps between the workstations (58) and the SCSI storage devices (60, 62, 64) and implements access controls for storage space on the SCSI storage devices (60, 62, 64). The storage router (56) then allows access from the workstations (58) to the SCSI storage devices (60, 62, 64) using native low level, block protocol in accordance with the mapping and the access controls.

FOR THE PURPOSES OF INFORMATION ONLY

Codes used to identify States party to the PCT on the front pages of pamphlets publishing international applications under the PCT.

AL	Albania	ES	Spain	LS	Lesotho	SI	Slovenia
AM	Armenia	FI	Finland	LT	Lithuania	SK	Slovakia
AT	Austria	FR	France	LU	Luxembourg	SN	Senegal
AU	Australia	GA	Gabon	LV	Latvia	SZ	Swaziland
AZ	Azerbaijan	GB	United Kingdom	MC	Monaco	TD	Chad
BA	Bosnia and Herzegovina	GE	Georgia	MD	Republic of Moldova	TG	Togo
BB	Barbados	GH	Ghana	MG	Madagascar	TJ	Tajikistan
BE	Belgium	GN	Guinea	MK	The former Yugoslav Republic of Macedonia	TM	Turkmenistan
BF	Burkina Faso	GR	Greece	ML	Mali	TR	Turkey
BG	Bulgaria	HU	Hungary	MN	Mongolia	TT	Trinidad and Tobago
BJ	Benin	IE	Ireland	MR	Mauritania	UA	Ukraine
BR	Brazil	IL	Israel	MW	Malawi	UG	Uganda
BY	Belarus	IS	Iceland	MX	Mexico	US	United States of America
CA	Canada	IT	Italy	NE	Niger	UZ	Uzbekistan
CF	Central African Republic	JP	Japan	NL	Netherlands	VN	Viet Nam
CG	Congo	KE	Kenya	NO	Norway	YU	Yugoslavia
CH	Switzerland	KG	Kyrgyzstan	NZ	New Zealand	ZW	Zimbabwe
CI	Côte d'Ivoire	KP	Democratic People's Republic of Korea	PL	Poland		
CM	Cameroon	KR	Republic of Korea	PT	Portugal		
CN	China	KZ	Kazakistan	RO	Romania		
CU	Cuba	LC	Saint Lucia	RU	Russian Federation		
CZ	Czech Republic	LI	Liechtenstein	SD	Sudan		
DE	Germany	LK	Sri Lanka	SE	Sweden		
DK	Denmark	LR	Liberia	SG	Singapore		
EE	Estonia						

STORAGE ROUTER AND METHOD FOR PROVIDING VIRTUAL LOCAL
STORAGE

TECHNICAL FIELD OF THE INVENTION

This invention relates in general to network storage devices, and more particularly to a storage router and method for providing virtual local storage on remote SCSI storage devices to Fibre Channel devices

BACKGROUND OF THE INVENTION

Typical storage transport mediums provide for a relatively small number of devices to be attached over relatively short distances. One such transport medium is a Small Computer System Interface (SCSI) protocol, the structure and operation of which is generally well known as is described, for example, in the SCSI-1, SCSI-2 and SCSI-3 specifications. High speed serial interconnects provide enhanced capability to attach a large number of high speed devices to a common storage transport medium over large distances. One such serial interconnect is Fibre Channel, the structure and operation of which is described, for example, in *Fibre Channel Physical and Signaling Interface (FC-PH)*, ANSI X3.230 *Fibre Channel Arbitrated Loop (FC-AL)*, and ANSI X3.272 *Fibre Channel Private Loop Direct Attach (FC-PLDA)*.

Conventional computing devices, such as computer workstations, generally access storage locally or through network interconnects. Local storage typically consists of a disk drive, tape drive, CD-ROM drive or other storage device contained within, or locally connected to the workstation. The workstation provides a file system structure, that includes security controls, with access to the local storage device through native low level, block protocols. These protocols map directly to the mechanisms used by the storage device and consist of data requests without security controls. Network interconnects typically provide access for a large number of computing

devices to data storage on a remote network server. The remote network server provides file system structure, access control, and other miscellaneous capabilities that include the network interface. Access to data through
5 the network server is through network protocols that the server must translate into low level requests to the storage device. A workstation with access to the server storage must translate its file system protocols into network protocols that are used to communicate with the
10 server. Consequently, from the perspective of a workstation, or other computing device, seeking to access such server data, the access is much slower than access to data on a local storage device.

SUMMARY OF THE INVENTION

In accordance with the present invention, a storage router and method for providing virtual local storage on remote SCSI storage devices to Fibre Channel devices are disclosed that provide advantages over conventional
5 network storage devices and methods.

According to one aspect of the present invention, a storage router and storage network provide virtual local storage on remote SCSI storage devices to Fibre Channel
10 devices. A plurality of Fibre Channel devices, such as workstations, are connected to a Fibre Channel transport medium, and a plurality of SCSI storage devices are connected to a SCSI bus transport medium. The storage
15 router interfaces between the Fibre Channel transport medium and the SCSI bus transport medium. The storage router maps between the workstations and the SCSI storage devices and implements access controls for storage space on the SCSI storage devices. The storage router then
20 allows access from the workstations to the SCSI storage devices using native low level, block protocol in accordance with the mapping and the access controls.

According to another aspect of the present invention, virtual local storage on remote SCSI storage devices is provided to Fibre Channel devices. A Fibre
25 Channel transport medium and a SCSI bus transport medium are interfaced with. A configuration is maintained for SCSI storage devices connected to the SCSI bus transport medium. The configuration maps between Fibre Channel

devices and the SCSI storage devices and implements access controls for storage space on the SCSI storage devices. Access is then allowed from Fibre Channel initiator devices to SCSI storage devices using native
5 low level, block protocol in accordance with the configuration.

A technical advantage of the present invention is the ability to centralize local storage for networked workstations without any cost of speed or overhead. Each
10 workstation access its virtual local storage as if it work locally connected. Further, the centralized storage devices can be located in a significantly remote position even in excess of ten kilometers as defined by Fibre Channel standards.

15 Another technical advantage of the present invention is the ability to centrally control and administer storage space for connected users without limiting the speed with which the users can access local data. In addition, global access to data, backups, virus scanning
20 and redundancy can be more easily accomplished by centrally located storage devices.

A further technical advantage of the present invention is providing support for SCSI storage devices as local storage for Fibre Channel hosts. In addition,
25 the present invention helps to provide extended capabilities for Fibre Channel and for management of storage subsystems.

BRIEF DESCRIPTION OF THE DRAWINGS

A more complete understanding of the present invention and the advantages thereof may be acquired by referring to the following description taken in
5 conjunction with the accompanying drawings, in which like reference numbers indicate like features, and wherein:

FIGURE 1 is a block diagram of a conventional network that provides storage through a network server;

10 FIGURE 2 is a block diagram of one embodiment of a storage network with a storage router that provides global access and routing;

FIGURE 3 is a block diagram of one embodiment of a storage network with a storage router that provides virtual local storage;

15 FIGURE 4 is a block diagram of one embodiment of the storage router of FIGURE 3; and

FIGURE 5 is a block diagram of one embodiment of data flow within the storage router of FIGURE 4.

DETAILED DESCRIPTION OF THE INVENTION

FIGURE 1 is a block diagram of a conventional network, indicated generally at 10, that provides access to storage through a network server. As shown, network 10 includes a plurality of workstations 12 interconnected with a network server 14 via a network transport medium 16. Each workstation 12 can generally comprise a processor, memory, input/output devices, storage devices and a network adapter as well as other common computer components. Network server 14 uses a SCSI bus 18 as a storage transport medium to interconnect with a plurality of storage devices 20 (tape drives, disk drives, etc.). In the embodiment of FIGURE 1, network transport medium 16 is an network connection and storage devices 20 comprise hard disk drives, although there are numerous alternate transport mediums and storage devices.

In network 10, each workstation 12 has access to its local storage device as well as network access to data on storage devices 20. The access to a local storage device is typically through native low level, block protocols. On the other hand, access by a workstation 12 to storage devices 20 requires the participation of network server 14 which implements a file system and transfers data to workstations 12 only through high level file system protocols. Only network server 14 communicates with storage devices 20 via native low level, block protocols. Consequently, the network access by workstations 12 through network server 14 is slow with respect to their

access to local storage. In network 10, it can also be a logistical problem to centrally manage and administer local data distributed across an organization, including accomplishing tasks such as backups, virus scanning and
5 redundancy.

FIGURE 2 is a block diagram of one embodiment of a storage network, indicated generally at 30, with a storage router that provides global access and routing. This environment is significantly different from that of
10 FIGURE 1 in that there is no network server involved. In FIGURE 2, a Fibre Channel high speed serial transport 32 interconnects a plurality of workstations 36 and storage devices 38. A SCSI bus storage transport medium
15 interconnects workstations 40 and storage devices 42. A storage router 44 then serves to interconnect these mediums and provide devices on either medium global, transparent access to devices on the other medium. Storage router 44 routes requests from initiator devices
20 on one medium to target devices on the other medium and routes data between the target and the initiator. Storage router 44 can allow initiators and targets to be on either side. In this manner, storage router 44 enhances the functionality of Fibre Channel 32 by
25 providing access, for example, to legacy SCSI storage devices on SCSI bus 34. In the embodiment of FIGURE 2, the operation of storage router 44 can be managed by a management station 46 connected to the storage router via a direct serial connection.

In storage network 30, any workstation 36 or workstation 40 can access any storage device 38 or storage device 42 through native low level, block protocols, and vice versa. This functionality is enabled by storage router 44 which routes requests and data as a generic transport between Fibre Channel 32 and SCSI bus 34. Storage router 44 uses tables to map devices from one medium to the other and distributes requests and data across Fibre Channel 32 and SCSI bus 34 without any security access controls. Although this extension of the high speed serial interconnect provided by Fibre Channel 32 is beneficial, it is desirable to provide security controls in addition to extended access to storage devices through a native low level, block protocol.

FIGURE 3 is a block diagram of one embodiment of a storage network, indicated generally at 50, with a storage router that provides virtual local storage. Similar to that of FIGURE 2, storage network 50 includes a Fibre Channel high speed serial interconnect 52 and a SCSI bus 54 bridged by a storage router 56. Storage router 56 of FIGURE 3 provides for a large number of workstations 58 to be interconnected on a common storage transport and to access common storage devices 60, 62 and 64 through native low level, block protocols.

According to the present invention, storage router 56 has enhanced functionality to implement security controls and routing such that each workstation 58 can have access to a specific subset of the overall data

stored in storage devices 60, 62 and 64. This specific subset of data has the appearance and characteristics of local storage and is referred to herein as virtual local storage. Storage router 56 allows the configuration and modification of the storage allocated to each attached workstation 58 through the use of mapping tables or other mapping techniques.

As shown in FIGURE 3, for example, storage device 60 can be configured to provide global data 65 which can be accessed by all workstations 58. Storage device 62 can be configured to provide partitioned subsets 66, 68, 70 and 72, where each partition is allocated to one of the workstations 58 (workstations A, B, C and D). These subsets 66, 68, 70 and 72 can only be accessed by the associated workstation 58 and appear to the associated workstation 58 as local storage accessed using native low level, block protocols. Similarly, storage device 64 can be allocated as storage for the remaining workstation 58 (workstation E).

Storage router 56 combines access control with routing such that each workstation 58 has controlled access to only the specified partition of storage device 62 which forms virtual local storage for the workstation 58. This access control allows security control for the specified data partitions. Storage router 56 allows this allocation of storage devices 60, 62 and 64 to be managed by a management station 76. Management station 76 can connect directly to storage router 56 via a direct

connection or, alternately, can interface with storage
router 56 through either Fibre Channel 52 or SCSI bus 54.
In the latter case, management station 76 can be a
workstation or other computing device with special rights
5 such that storage router 56 allows access to mapping
tables and shows storage devices 60, 62 and 64 as they
exist physically rather than as they have been allocated.

The environment of FIGURE 3 extends the concept of a
single workstation having locally connected storage
10 devices to a storage network 50 in which workstations 58
are provided virtual local storage in a manner
transparent to workstations 58. Storage router 56
provides centralized control of what each workstation 58
sees as its local drive, as well as what data it sees as
15 global data accessible by other workstations 58.
Consequently, the storage space considered by the
workstation 58 to be its local storage is actually a
partition (i.e., logical storage definition) of a
physically remote storage device 60, 62 or 64 connected
20 through storage router 56. This means that similar
requests from workstations 58 for access to their local
storage devices produce different accesses to the storage
space on storage devices 60, 62 and 64. Further, no
access from a workstation 58 is allowed to the virtual
25 local storage of another workstation 58.

The collective storage provided by storage devices
60, 62 and 64 can have blocks allocated by programming
means within storage router 56. To accomplish this

function, storage router 56 can include routing tables and security controls that define storage allocation for each workstation 58. The advantages provided by implementing virtual local storage in centralized storage devices include the ability to do collective backups and other collective administrative functions more easily. This is accomplished without limiting the performance of workstations 58 because storage access involves native low level, block protocols and does not involve the overhead of high level protocols and file systems required by network servers.

FIGURE 4 is a block diagram of one embodiment of storage router 56 of FIGURE 3. Storage router 56 can comprise a Fibre Channel controller 80 that interfaces with Fibre Channel 52 and a SCSI controller 82 that interfaces with SCSI bus 54. A buffer 84 provides memory work space and is connected to both Fibre Channel controller 80 and to SCSI controller 82. A supervisor unit 86 is connected to Fibre Channel controller 80, SCSI controller 82 and buffer 84. Supervisor unit 86 comprises a microprocessor for controlling operation of storage router 56 and to handle mapping and security access for requests between Fibre Channel 52 and SCSI bus 54.

FIGURE 5 is a block diagram of one embodiment of data flow within storage router 56 of FIGURE 4. As shown, data from Fibre Channel 52 is processed by a Fibre Channel (FC) protocol unit 88 and placed in a FIFO queue

90. A direct memory access (DMA) interface 92 then takes data out of FIFO queue 90 and places it in buffer 84. Supervisor unit 86 processes the data in buffer 84 as represented by supervisor processing 93. This processing
5 involves mapping between Fibre Channel 52 and SCSI bus 54 and applying access controls and routing functions. A DMA interface 94 then pulls data from buffer 84 and places it into a buffer 96. A SCSI protocol unit 98
10 pulls data from buffer 96 and communicates the data on SCSI bus 54. Data flow in the reverse direction, from SCSI bus 54 to Fibre Channel 52, is accomplished in a reverse manner.

The storage router of the present invention is a bridge device that connects a Fibre Channel link directly
15 to a SCSI bus and enables the exchange of SCSI command set information between application clients on SCSI bus devices and the Fibre Channel links. Further, the storage router applies access controls such that virtual
20 local storage can be established in remote SCSI storage devices for workstations on the Fibre Channel link. In one embodiment, the storage router provides a connection for Fibre Channel links running the SCSI Fibre Channel Protocol (FCP) to legacy SCSI devices attached to a SCSI
25 bus. The Fibre Channel topology is typically an Arbitrated Loop (FC_AL).

In part, the storage router enables a migration path to Fibre Channel based, serial SCSI networks by providing connectivity for legacy SCSI bus devices. The storage

router can be attached to a Fibre Channel Arbitrated Loop and a SCSI bus to support a number of SCSI devices. Using configuration settings, the storage router can make the SCSI bus devices available on the Fibre Channel network as FCP logical units. Once the configuration is defined, operation of the storage router is transparent to application clients. In this manner, the storage router can form an integral part of the migration to new Fibre Channel based networks while providing a means to continue using legacy SCSI devices.

In one implementation (not shown), the storage router can be a rack mount or free standing device with an internal power supply. The storage router can have a Fibre Channel and SCSI port, and a standard, detachable power cord can be used, the FC connector can be a copper DB9 connector, and the SCSI connector can be a 68-pin type. Additional modular jacks can be provided for a serial port and a 802.3 10BaseT port, i.e. twisted pair Ethernet, for management access. The SCSI port of the storage router can support SCSI direct and sequential access target devices and can support SCSI initiators, as well. The Fibre Channel port can interface to SCSI-3 FCP enabled devices and initiators.

To accomplish its functionality, one implementation of the storage router uses: a Fibre Channel interface based on the HEWLETT-PACKARD TACHYON HPFC-5000 controller and a GLM media interface; an Intel 80960RP processor, incorporating independent data and program memory spaces,

and associated logic required to implement a stand alone processing system; and a serial port for debug and system configuration. Further, this implementation includes a SCSI interface supporting Fast-20 based on the SYMBIOS
5 53C8xx series SCSI controllers, and an operating system based upon the WIND RIVERS SYSTEMS VXWORKS or IXWORKS kernel, as determined by design. In addition, the storage router includes software as required to control basic functions of the various elements, and to provide
10 appropriate translations between the FC and SCSI protocols.

The storage router has various modes of operation that are possible between FC and SCSI target and initiator combinations. These modes are: FC Initiator to
15 SCSI Target; SCSI Initiator to FC Target; SCSI Initiator to SCSI Target; and FC Initiator to FC Target. The first two modes can be supported concurrently in a single storage router device are discussed briefly below. The third mode can involve two storage router devices
20 back to back and can serve primarily as a device to extend the physical distance beyond that possible via a direct SCSI connection. The last mode can be used to carry FC protocols encapsulated on other transmission technologies (e.g. ATM, SONET), or to act as a bridge
25 between two FC loops (e.g. as a two port fabric).

The FC Initiator to SCSI Target mode provides for the basic configuration of a server using Fibre Channel to communicate with SCSI targets. This mode requires

that a host system have an FC attached device and associated device drivers and software to generate SCSI-3 FCP requests. This system acts as an initiator using the storage router to communicate with SCSI target devices.

5 The SCSI devices supported can include SCSI-2 compliant direct or sequential access (disk or tape) devices. The storage router serves to translate command and status information and transfer data between SCSI-3 FCP and SCSI-2, allowing the use of standard SCSI-2 devices in a
10 Fibre Channel environment.

The SCSI Initiator to FC Target mode provides for the configuration of a server using SCSI-2 to communicate with Fibre Channel targets. This mode requires that a host system has a SCSI-2 interface and driver software to
15 control SCSI-2 target devices. The storage router will connect to the SCSI-2 bus and respond as a target to multiple target IDs. Configuration information is required to identify the target IDs to which the bridge will respond on the SCSI-2 bus. The storage router then
20 translates the SCSI-2 requests to SCSI-3 FCP requests, allowing the use of FC devices with a SCSI host system. This will also allow features such as a tape device acting as an initiator on the SCSI bus to provide full support for this type of SCSI device.

25 In general, user configuration of the storage router will be needed to support various functional modes of operation. Configuration can be modified, for example, through a serial port or through an Ethernet port via

SNMP (simple network management protocol) or a Telnet session. Specifically, SNMP manageability can be provided via an 802.3 Ethernet interface. This can provide for configuration changes as well as providing
5 statistics and error information. Configuration can also be performed via TELNET or RS-232 interfaces with menu driven command interfaces. Configuration information can be stored in a segment of flash memory and can be retained across resets and power off cycles. Password
10 protection can also be provided.

In the first two modes of operation, addressing information is needed to map from FC addressing to SCSI addressing and vice versa. This can be 'hard'
15 configuration data, due to the need for address information to be maintained across initialization and partial reconfigurations of the Fibre Channel address space. In an arbitrated loop configuration, user configured addresses will be needed for AL_PAs in order to insure that known addresses are provided between loop
20 reconfigurations.

With respect to addressing, FCP and SCSI 2 systems employ different methods of addressing target devices. Additionally, the inclusion of a storage router means that a method of translating device IDs needs to be
25 implemented. In addition, the storage router can respond to commands without passing the commands through to the opposite interface. This can be implemented to allow all generic FCP and SCSI commands to pass through the storage

router to address attached devices, but allow for configuration and diagnostics to be performed directly on the storage router through the FC and SCSI interfaces.

5 Management commands are those intended to be processed by the storage router controller directly. This may include diagnostic, mode, and log commands as well as other vendor-specific commands. These commands can be received and processed by both the FCP and SCSI interfaces, but are not typically bridged to the opposite
10 interface. These commands may also have side effects on the operation of the storage router, and cause other storage router operations to change or terminate.

A primary method of addressing management commands though the FCP and SCSI interfaces can be through
15 peripheral device type addressing. For example, the storage router can respond to all operations addressed to logical unit (LUN) zero as a controller device. Commands that the storage router will support can include INQUIRY as well as vendor-specific management commands. These
20 are to be generally consistent with SCC standard commands.

The SCSI bus is capable of establishing bus connections between targets. These targets may internally address logical units. Thus, the prioritized
25 addressing scheme used by SCSI subsystems can be represented as follows: BUS:TARGET:LOGICAL UNIT. The BUS identification is intrinsic in the configuration, as a SCSI initiator is attached to only one bus. Target

addressing is handled by bus arbitration from information provided to the arbitrating device. Target addresses are assigned to SCSI devices directly, though some means of configuration, such as a hardware jumper, switch setting, or device specific software configuration. As such, the SCSI protocol provides only logical unit addressing within the Identify message. Bus and target information is implied by the established connection.

Fibre Channel devices within a fabric are addressed by a unique port identifier. This identifier is assigned to a port during certain well-defined states of the FC protocol. Individual ports are allowed to arbitrate for a known, user defined address. If such an address is not provided, or if arbitration for a particular user address fails, the port is assigned a unique address by the FC protocol. This address is generally not guaranteed to be unique between instances. Various scenarios exist where the AL-PA of a device will change, either after power cycle or loop reconfiguration.

The FC protocol also provides a logical unit address field within command structures to provide addressing to devices internal to a port. The FCP_CMD payload specifies an eight byte LUN field. Subsequent identification of the exchange between devices is provided by the FQXID (Fully Qualified Exchange ID).

FC ports can be required to have specific addresses assigned. Although basic functionality is not dependent on this, changes in the loop configuration could result

in disk targets changing identifiers with the potential risk of data corruption or loss. This configuration can be straightforward, and can consist of providing the device a loop-unique ID (AL_PA) in the range of "01h" to "EFh." Storage routers could be shipped with a default value with the assumption that most configurations will be using single storage routers and no other devices requesting the present ID. This would provide a minimum amount of initial configuration to the system administrator. Alternately, storage routers could be defaulted to assume any address so that configurations requiring multiple storage routers on a loop would not require that the administrator assign a unique ID to the additional storage routers.

Address translation is needed where commands are issued in the cases FC Initiator to SCSI Target and SCSI Initiator to FC Target. Target responses are qualified by the FQXID and will retain the translation acquired at the beginning of the exchange. This prevents configuration changes occurring during the course of execution of a command from causing data or state information to be inadvertently misdirected. Configuration can be required in cases of SCSI Initiator to FC Target, as discovery may not effectively allow for FCP targets to consistently be found. This is due to an FC arbitrated loop supporting addressing of a larger number of devices than a SCSI bus and the possibility of FC devices changing their AL-PA due to device insertion

or other loop initialization.

In the direct method, the translation to
BUS:TARGET:LUN of the SCSI address information will be
direct. That is, the values represented in the FCP LUN
5 field will directly map to the values in effect on the
SCSI bus. This provides a clean translation and does not
require SCSI bus discovery. It also allows devices to be
dynamically added to the SCSI bus without modifying the
address map. It may not allow for complete discovery by
10 FCP initiator devices, as gaps between device addresses
may halt the discovery process. Legacy SCSI device
drivers typically halt discovery on a target device at
the first unoccupied LUN, and proceed to the next target.
This would lead to some devices not being discovered.
15 However, this allows for hot plugged devices and other
changes to the loop addressing.

In the ordered method, ordered translation requires
that the storage router perform discovery on reset, and
collapses the addresses on the SCSI bus to sequential FCP
20 LUN values. Thus, the FCP LUN values 0-N can represent
N+1 SCSI devices, regardless of SCSI address values, in
the order in which they are isolated during the SCSI
discovery process. This would allow the FCP initiator
discovery process to identify all mapped SCSI devices
25 without further configuration. This has the limitation
that hot-plugged devices will not be identified until the
next reset cycle. In this case, the address may also be
altered as well.

In addition to addressing, according to the present invention, the storage router provides configuration and access controls that cause certain requests from FC Initiators to be directed to assigned virtual local storage partitioned on SCSI storage devices. For example, the same request for LUN 0 (local storage) by two different FC Initiators can be directed to two separate subsets of storage. The storage router can use tables to map, for each initiator, what storage access is available and what partition is being addressed by a particular request. In this manner, the storage space provided by SCSI storage devices can be allocated to FC initiators to provide virtual local storage as well as to create any other desired configuration for secured access.

Although the present invention has been described in detail, it should be understood that various changes, substitutions, and alterations can be made hereto without departing from the spirit and scope of the invention as defined by the appended claims.

WHAT IS CLAIMED IS:

1. A storage router for providing virtual local storage on remote SCSI storage devices to Fibre Channel devices, comprising:

5 a buffer providing memory work space for the storage router;

a Fibre Channel controller operable to connect to and interface with a Fibre Channel transport medium;

10 a SCSI controller operable to connect to and interface with a SCSI bus transport medium; and

a supervisor unit coupled to the Fibre Channel controller, the SCSI controller and the buffer, the supervisor unit operable:

15 to maintain a configuration for SCSI storage devices connected to the SCSI bus transport medium that maps between Fibre Channel devices and SCSI storage devices and that implements access controls for storage space on the SCSI storage devices; and

20 to process data in the buffer to interface between the Fibre Channel controller and the SCSI controller to allow access from Fibre Channel initiator devices to SCSI storage devices using native low level, block protocol in accordance with the configuration.

2. The storage router of Claim 1, wherein the configuration maintained by the supervisor unit includes an allocation of subsets of storage space to associated Fibre Channel devices, wherein each subset is only
5 accessible by the associated Fibre Channel device.

3. The storage router of Claim 2, wherein the Fibre Channel devices comprise workstations.

10 4. The storage router of Claim 2, wherein the SCSI storage devices comprise hard disk drives.

5. The storage router of Claim 1, wherein the Fibre Channel controller comprises:
15 a Fibre Channel (FC) protocol unit operable to connect to the Fibre Channel transport medium;
a first-in-first-out queue coupled to the Fibre Channel protocol unit; and
a direct memory access (DMA) interface coupled to
20 the first-in-first-out queue and to the buffer.

6. The storage router of Claim 1, wherein the SCSI controller comprises:
a SCSI protocol unit operable to connect to the SCSI
25 bus transport medium;
an internal buffer coupled to the SCSI protocol unit; and
a direct memory access (DMA) interface coupled to

the internal buffer and to the buffer of the storage router.

- 5 7. A storage network, comprising:
a Fibre Channel transport medium;
a SCSI bus transport medium;
a plurality of workstations connected to the Fibre Channel transport medium;
a plurality of SCSI storage devices connected to the
10 SCSI bus transport medium; and
a storage router interfacing between the Fibre Channel transport medium and the SCSI bus transport medium, the storage router providing virtual local storage on the SCSI storage devices to the workstations
15 and operable:
to map between the workstations and the SCSI storage devices;
to implement access controls for storage space on the SCSI storage devices; and
20 to allow access from the workstations to the SCSI storage devices using native low level, block protocol in accordance with the mapping and access controls.
- 25 8. The storage network of Claim 7, wherein the access controls include an allocation of subsets of storage space to associated workstations, wherein each subset is only accessible by the associated workstation.

9. The storage network of Claim 7, wherein the SCSI storage devices comprise hard disk drives.

5 10. The storage network of Claim 7, wherein the storage router comprises:

a buffer providing memory work space for the storage router;

10 a Fibre Channel controller operable to connect to and interface with a Fibre Channel transport medium, the Fibre Channel controller further operable to pull outgoing data from the buffer and to place incoming data into the buffer;

15 a SCSI controller operable to connect to and interface with a SCSI bus transport medium, the SCSI controller further operable to pull outgoing data from the buffer and to place incoming data into the buffer; and

20 a supervisor unit coupled to the Fibre Channel controller, the SCSI controller and the buffer, the supervisor unit operable:

25 to maintain a configuration for the SCSI storage devices that maps between Fibre Channel devices and SCSI storage devices and that implements the access controls for storage space on the SCSI storage devices; and

to process data in the buffer to interface between the Fibre Channel controller and the SCSI

controller to allow access from workstations to SCSI storage devices in accordance with the configuration.

11. A method for providing virtual local storage on remote SCSI storage devices to Fibre Channel devices, comprising:

interfacing with a Fibre Channel transport medium;
interfacing with a SCSI bus transport medium;
maintaining a configuration for SCSI storage devices connected to the SCSI bus transport medium that maps between Fibre Channel devices and the SCSI storage devices and that implements access controls for storage space on the SCSI storage devices; and
allowing access from Fibre Channel initiator devices to SCSI storage devices using native low level, block protocol in accordance with the configuration.

12. The method of Claim 11, wherein maintaining the configuration includes allocating subsets of storage space to associated Fibre Channel devices, wherein each subset is only accessible by the associated Fibre Channel device.

13. The method of Claim 12, wherein the Fibre Channel devices comprise workstations.

14. The method of Claim 12, wherein the SCSI storage devices comprise hard disk drives.

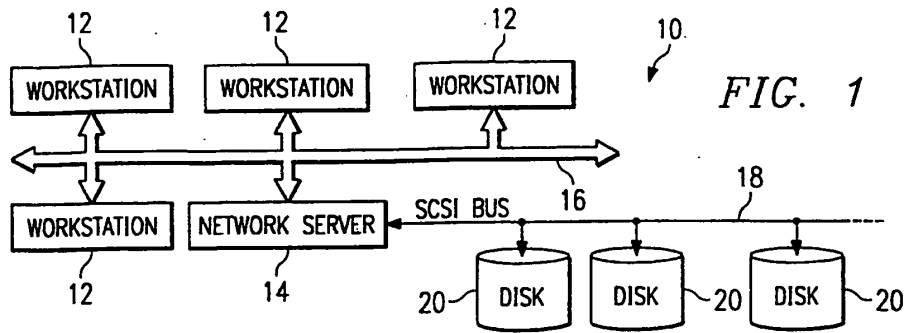

FIG. 1

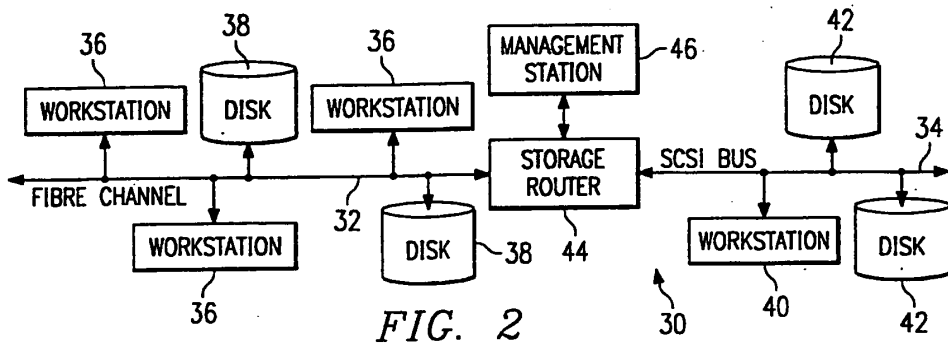

FIG. 2

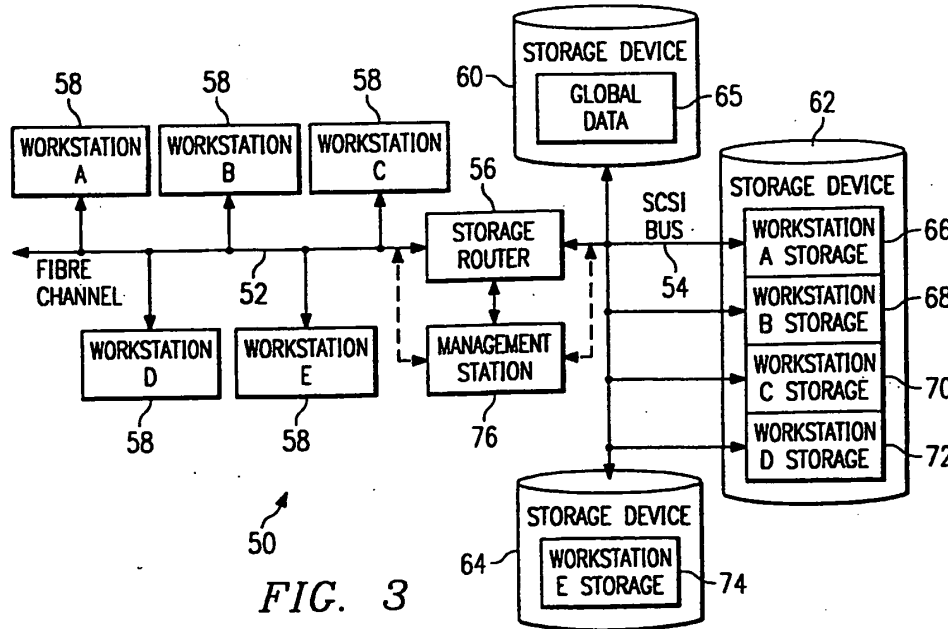
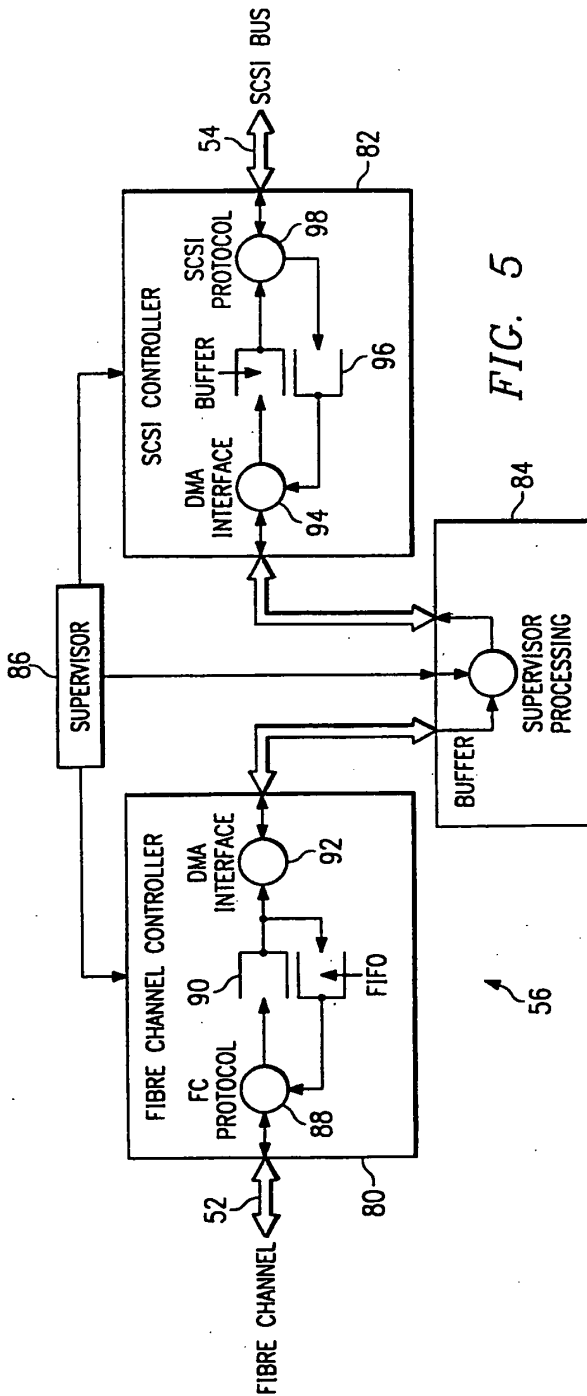
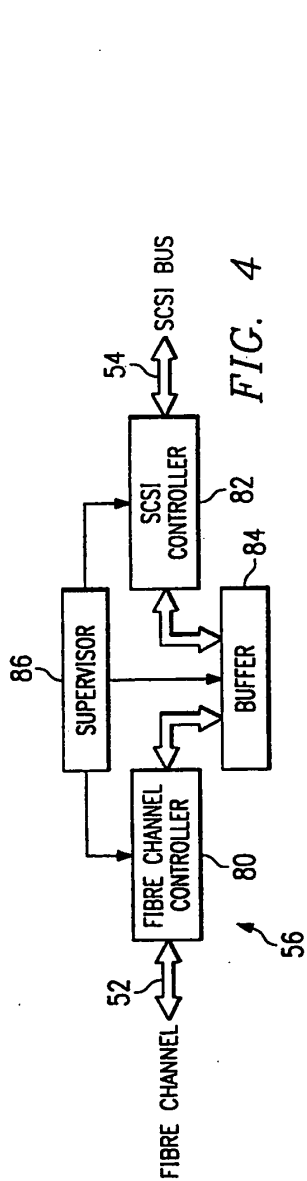

FIG. 3



INTERNATIONAL SEARCH REPORT

International application No.
PCT/US98/27689

A. CLASSIFICATION OF SUBJECT MATTER IPC(6) :G06F 13/00 US CL :710/129, 128, 2 According to International Patent Classification (IPC) or to both national classification and IPC		
B. FIELDS SEARCHED Minimum documentation searched (classification system followed by classification symbols) U.S. : 710/129, 128, 2 Documentation searched other than minimum documentation to the extent that such documents are included in the fields searched Electronic data base consulted during the international search (name of data base and, where practicable, search terms used) STN, APS, DIALOG		
C. DOCUMENTS CONSIDERED TO BE RELEVANT		
Category*	Citation of document, with indication, where appropriate, of the relevant passages	Relevant to claim No.
A	US 5,748,924 A (LLORENS et al.) 05 May 1998, entire document	1-14
A	US 5,835,496 A (YEUNG et al.) 10 November 1998, entire document	1-14
A	US 5,768,623 A (JUDD et al.) 16 June 1998, entire document	1-14
A	US 5,809,328 A (NOGALES et al.) 15 September 1998, entire document	1-14
A	US 5,812,754 A (LUI et al.) 22 September 1998, entire document	1-14
<input type="checkbox"/> Further documents are listed in the continuation of Box C. <input type="checkbox"/> See patent family annex.		
* Special categories of cited documents: *A* document defining the general state of the art which is not considered to be of particular relevance *B* earlier document published on or after the international filing date *L* document which may throw doubts on priority claim(s) or which is cited to establish the publication date of another citation or other special reason (as specified) *O* document referring to an oral disclosure, use, exhibition or other means *P* document published prior to the international filing date but later than the priority date claimed *T* later document published after the international filing date or priority date and not in conflict with the application but cited to understand the principle or theory underlying the invention *X* document of particular relevance; the claimed invention cannot be considered novel or cannot be considered to involve an inventive step when the document is taken alone *Y* document of particular relevance; the claimed invention cannot be considered to involve an inventive step when the document is combined with one or more other such documents, such combination being obvious to a person skilled in the art *Z* document member of the same patent family		
Date of the actual completion of the international search 12 MARCH 1999		Date of mailing of the international search report 05 APR 1999
Name and mailing address of the ISA/US Commissioner of Patents and Trademarks Box PCT Washington, D.C. 20231 Facsimile No. (703) 305-3230		Authorized officer CHRISTOPHER SHIN <i>Christopher Shin</i> Telephone No. (703) 305-9600

Form PCT/ISA/210 (second sheet)(July 1992) *

157

(12) UK Patent Application (19) GB (11) 2 341 715 (13) A

(43) Date of A Publication 22.03.2000

(21) Application No 9820213.8

(22) Date of Filing 17.09.1998

(71) Applicant(s)
Springtek Limited
(Incorporated in the United Kingdom)
Unit 3 Ashbrook Mews, Westbrook Street,
BLEWBURY, Oxon, OX11 9QA, United Kingdom

(72) Inventor(s)
Andrew Paul George Randall

(74) Agent and/or Address for Service
Atkinson Burrington
The Technology Park, 60 Shirland Lane, SHEFFIELD,
S9 3SP, United Kingdom

(51) INT CL⁷
G11B 20/18

(52) UK CL (Edition R)
G5R RB33 RGB

(56) Documents Cited
EP 0795812 A1 EP 0717357 A2 EP 0569313 A2
EP 0569236 A2 EP 0485110 A2 EP 0450801 A2
WO 93/18455 A1 WO 91/20076 A1 WO 91/14982 A1
US 5651132 A

(58) Field of Search
UK CL (Edition P) G4A AES, G5R RAC RB33 RGB
INT CL⁶ G06F 11/10, G11B 20/18
EDOC WPI

(54) Abstract Title
Magnetic disk redundant array

(57) A plurality of magnetic disk drives (301, 302, 303) are configured to store machine readable data in a protected way such that data is recoverable in the event of a single disk failure. The array of disks is housed for application directly into an existing disk bay of a computer (101). The array is connectable to the computer as if it were a single conventional computer disk and the drives are controlled by an operating system on the computer as if they were a single storage volume.

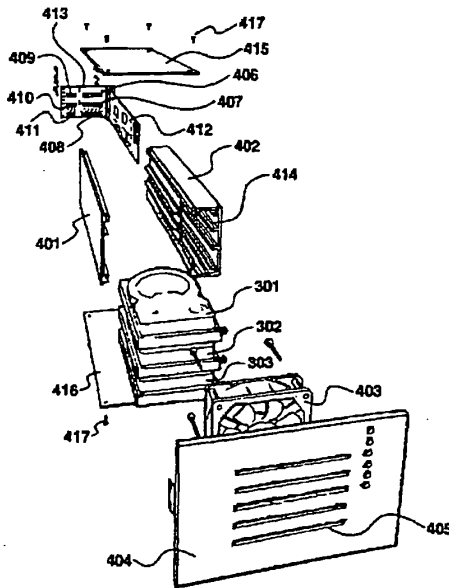

Figure 4

At least one drawing originally filed was informal and the print reproduced here is taken from a later filed formal copy.

This print takes account of replacement documents submitted after the date of filing to enable the application to comply with the formal requirements of the Patents Rules 1995

GB 2 341 715 A

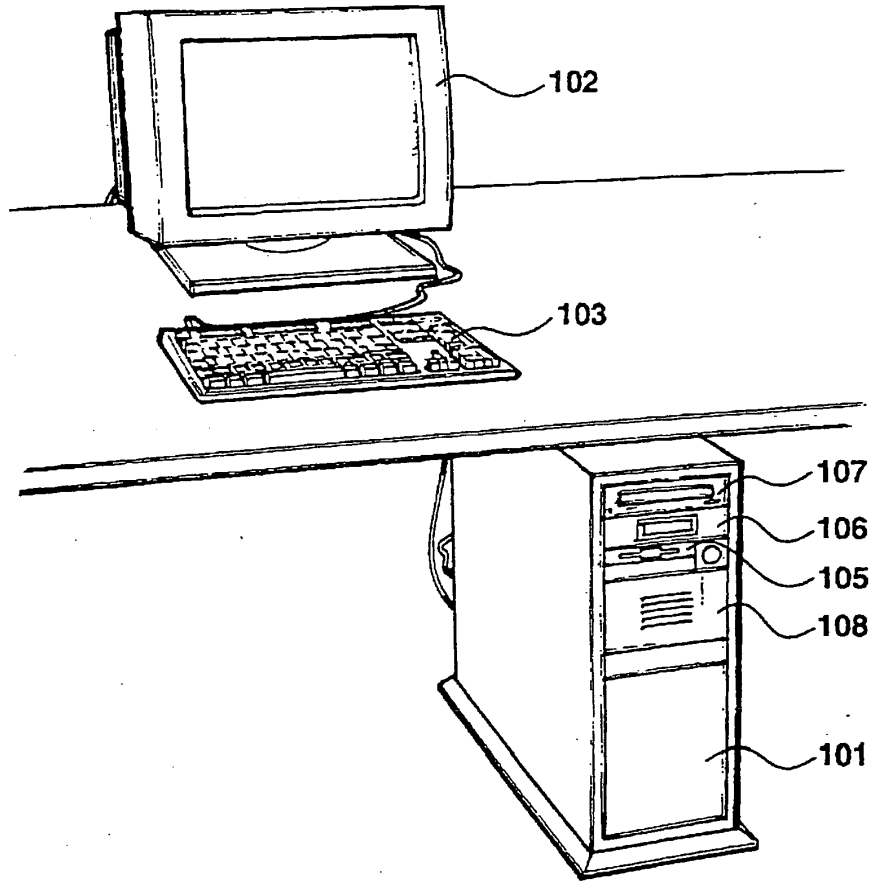

Figure 1

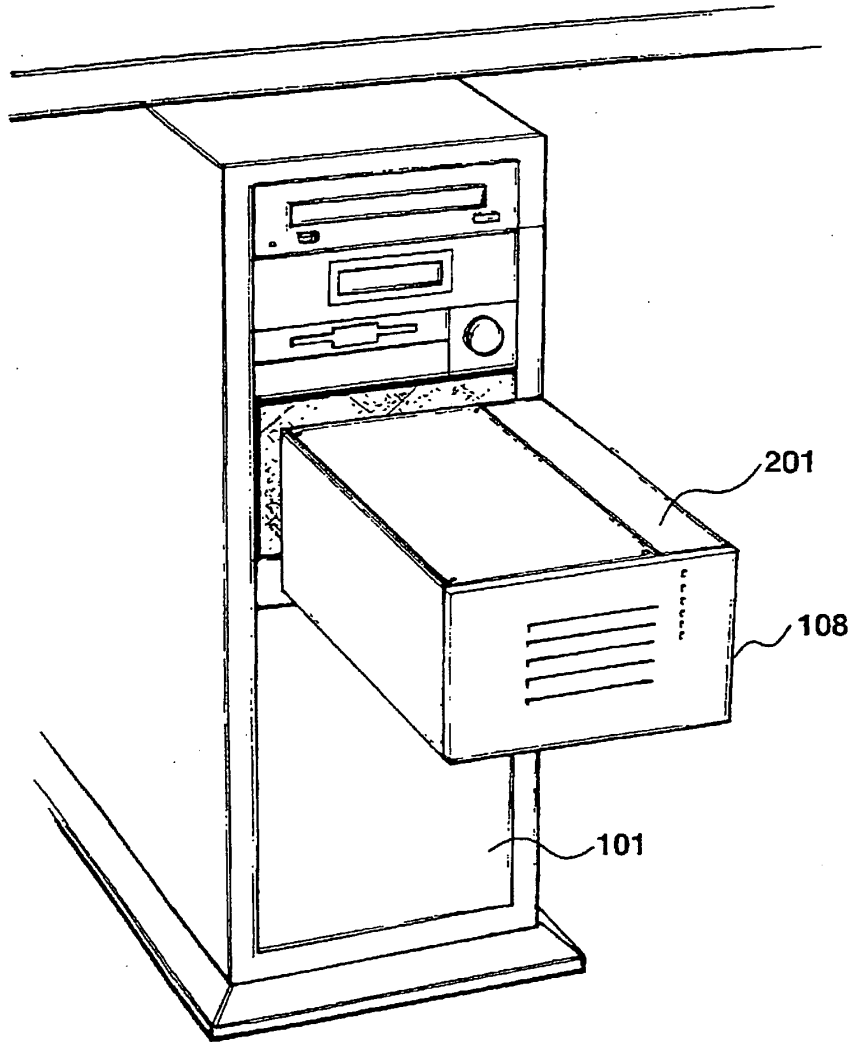

Figure 2

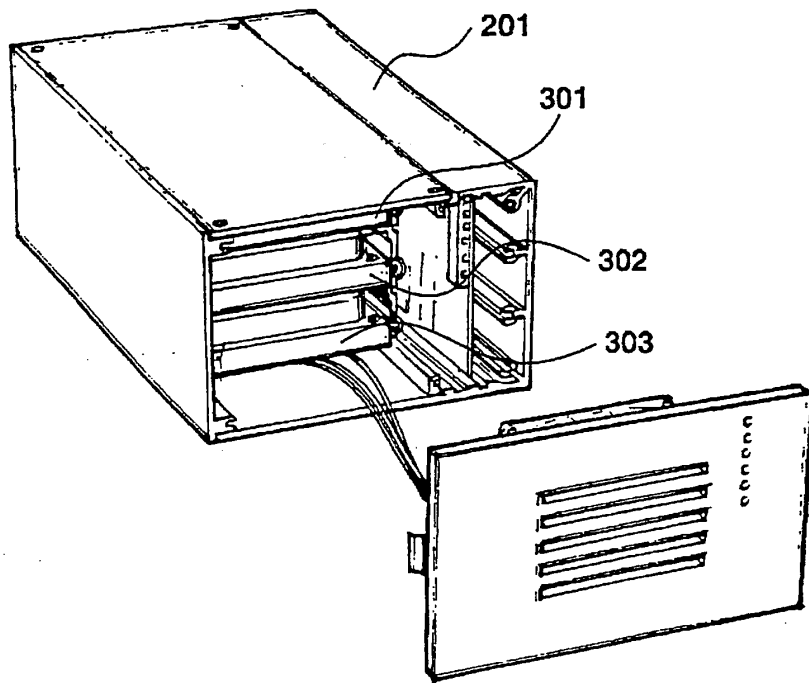

Figure 3

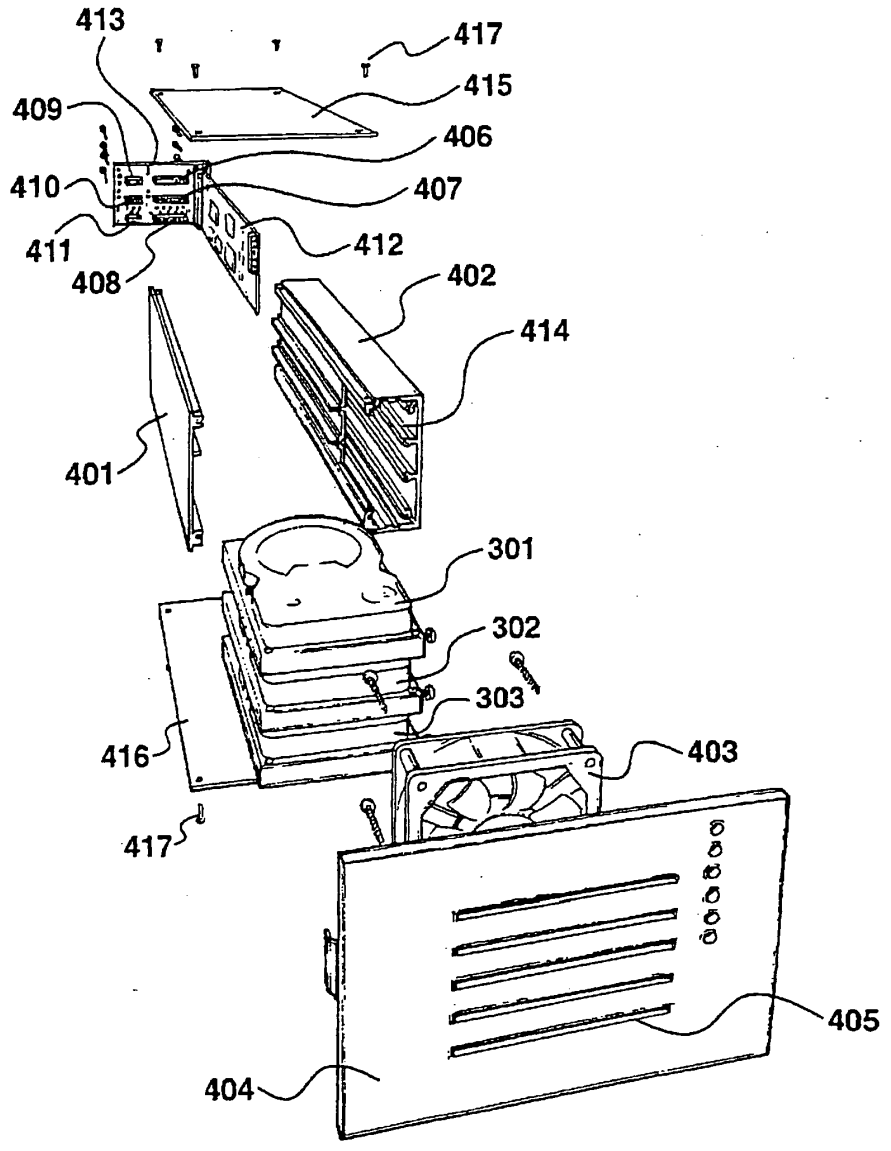

Figure 4

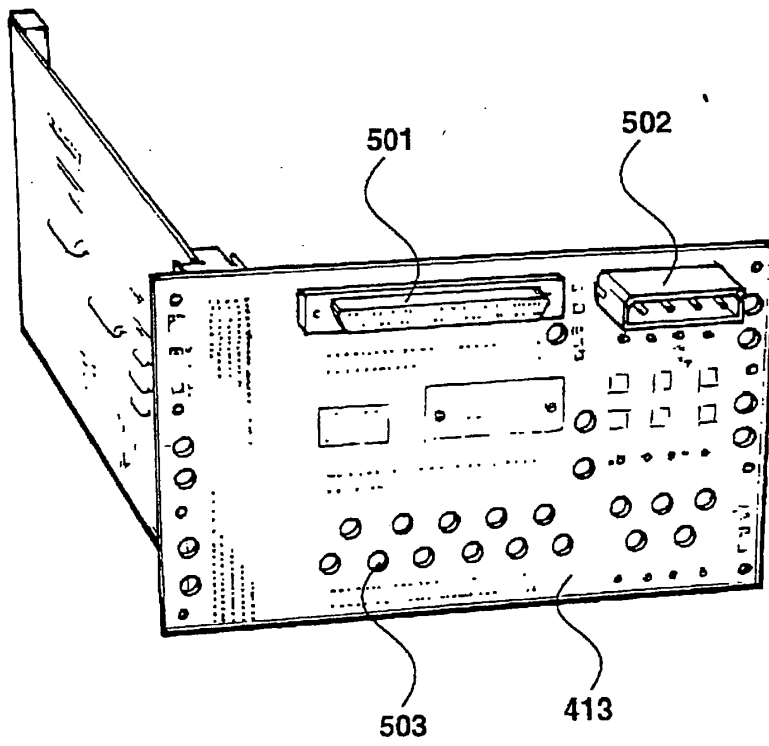

Figure 5

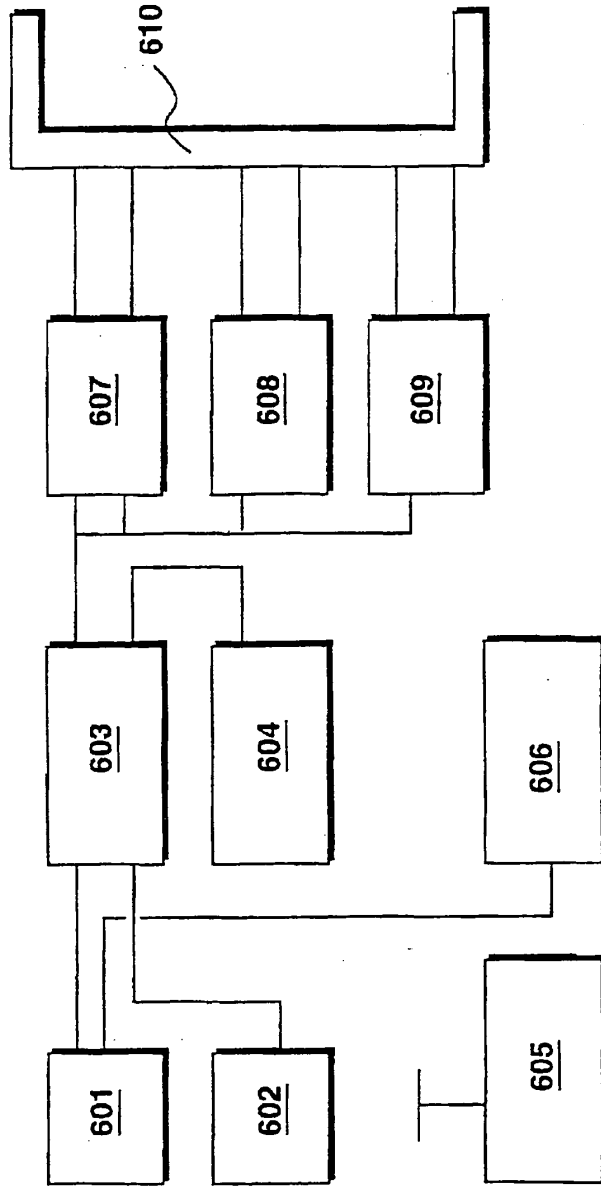

Figure 6

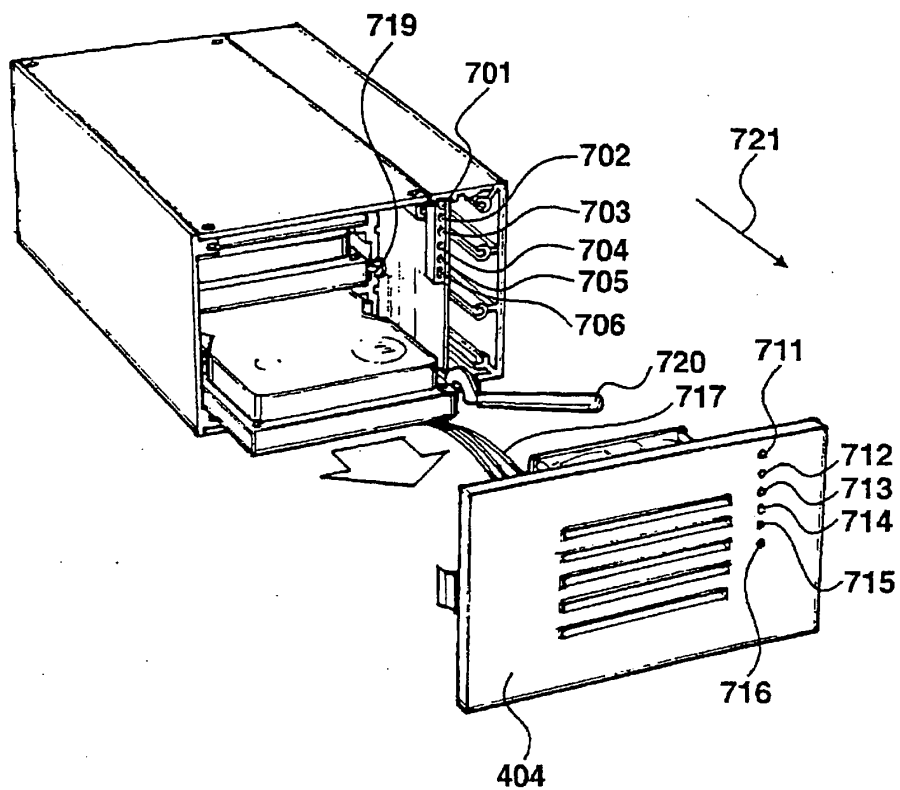

Figure 7

8/8

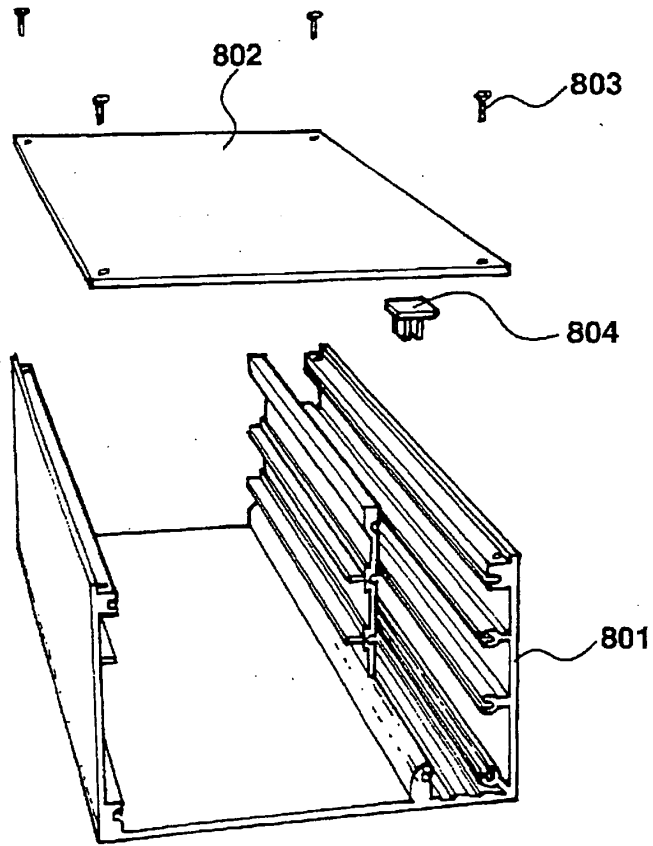

Figure 8

Data Storage

The present invention relates to an array of magnetic disks configured to store machine readable data in a protected way, such that data is recoverable in the event of disk failure.

Arrays configured to store machine readable data in a protected way are known and are often referred to as a redundant array of inexpensive disks, usually abbreviated to the acronym "RAID". Several RAID procedures are known and most of these share the approach of generating redundant data by an exclusive ORing process from which, in the event of any of the disks failing, all of the data can be reconstituted from the remaining operational disks.

When all of the disks are operational, the array is said to be working in its protected mode. In the event of one disk failure, the system may still remain operational, in that data may be read from the disks, but the data ceases to be protected and a further disk failure would result in data loss. With a single disk failure the system is said to be working in an unprotected mode at which point an operator would be advised that disk replacement is required and that the lost data needs to be reconstituted. Thus, a disk would be physically removed, replaced and then the lost data would be reconstituted on to the new disk.

As personal computer systems and workstations become more powerful, allowing more sophisticated software applications to be executed and the degree of data storage available in such systems increases, with disks containing several gigabytes of data now becoming widely used, a greater demand has been created for the installation of protected systems using disk redundancy. Complete RAID subsystems may be purchased for external connection but a problem with such known systems is that the cost can be very prohibitive. In many situations, the cost of such a RAID system

tends to be higher than the cost of a personal computer system. Thus, there is a requirement for providing RAID protection at reduced cost.

Personal computer systems are usually housed in desktop units or tower units having spare bays allowing additional disks to be received. Thus, it is possible for many hard disk drives to be included within a tower housing and additional interface cards may be provided if required. Thereafter, it is possible for the RAID calculations to be effected by the resident host CPU, such that the additional extra cost is quite modest. However, a major problem with such a configuration is that a significant processor overhead is required in order to perform the RAID calculations, resulting in a severe degradation in overall system performance.

According to a first aspect of the present invention, there is provided a plurality of data storage devices configured to store machine readable data in a protected way such that data is recoverable in the event of a single device failure, wherein the devices are housed for application directly into an existing disk bay for a computer; the devices are connectable to a disk interface as if they were a single conventional storage volume; and said devices are controlled by an operating system installed on a computer as if they were a single storage volume.

In a preferred embodiment, the disks are interfaced to an IDE connection and three disks may be received in respective IDE connections.

Preferably, the array presents a SCSI interface to a host computer and the array may be configured to be housed in two or more five and one quarter inch drive bays.

According to a second aspect of the present invention, there is provided a method of equipping a personal computer with a plurality of data storage devices configured as a redundant array by interfacing said devices to conventional five and one quarter inch drive bays, such that protected machine readable data is recoverable in the event of a single disk failure, comprising the steps of supporting the array within an existing disk bay for a

computer, connecting the array to the computer as if it were a single conventional computer disk; and controlling said drives by an operating system installed on a computer as if it were a single storage volume.

The invention will now be described by way of example only, with reference to the accompanying drawings, in which:

Figure 1 shows a personal computer system;

Figure 2 shows an array of disks being inserted into a computer system;

Figure 3 details the array shown in *Figure 2*;

Figure 4 shows an exploded view of the array identified in *Figure 3*;

Figure 5 shows a rear face view of the array back plane;

Figure 6 shows a circuit for implementing RAID calculations; and

Figure 7 illustrates the removal of a damaged disk from the array; and

Figure 8 shows an alternative embodiment for the extrusion identified in *Figure 4*.

A personal computer system is shown in *Figure 1* in which a main system tower 101 supplies visual information to a visual display unit 102 and receives manual commands via a keyboard 103. The main system tower houses a central processing unit, memory circuits and other standard associated electronics as is well known in the art. The personal computer system may be an IBM PC type system, a Mackintosh system or any other computer type equipment used for individual use, possibly in a networked configuration. Alternatively, the main system tower 101 may constitute a network server, possibly running an appropriate server operating system, such as Windows NT server.

Tower 101 includes conventional five and one quarter inch disk bays. Within these disk bays a plurality of devices have been mounted, including a three and a half inch floppy disk drive 105, a tape streamer 106, a CD ROM drive 107 and an array of magnetic disks 108, embodying the present invention.

Array 108 is detailed in *Figure 2* and is shown being installed into the main system tower 101. The array 108 of magnetic disks is configured to store machine readable data in a protected way such that data is recoverable in the event of a single disk failure. The array of disks is housed for application directly into an existing disk bay of a computer, such as the main system tower 101. The array is connectable to the computer as if it were a single conventional computer disk and the array is operated by an operating system installed on the computer as if it were a single disk.

Each empty drive bay is protected by a removable plastic cover and unit 107 locates within an aperture equivalent to the width of two bays, requiring the removal of two such covers. The array includes a housing 201, locatable within the two bay aperture and towards its rear includes conventional power and data connectors; such that the housing as a whole is connected to the main system tower using a conventional SCSI connection. Thus, the main system perceives the disk array as if it were a single disk and the operating system, executed by the main system, controls the operation of the array using equivalent commands to those required for the operation of a single storage volume.

The array 107 is detailed in *Figure 3* and contains a total of three IDE drives 301, 302 and 303. An exploded view of the array is illustrated in *Figure 4*, which shows each of the individual IDE drives 301, 302 and 303 being supported by aluminium extrusions, in the form of a left extrusion 401 and a right extrusion 402. These extrusions hold the disk drives 301, 302 and 303 firmly in place and facilitate the removal and replacement of individual disk drives when disk failure occurs.

Disk drives 301, 302 and 303 are located in relatively close proximity and in order to maintain preferred operational temperatures, an electric fan 403 is positioned between the front of the disk drives and a front housing 404. In this respect, the main front housing includes ventilation grilles 405.

Each IDE drive 301, 302 and 303 locates within a conventional IDE socket 406, 407, 408, in addition to respective power supply sockets 409, 410, 411. Thus, from the perspective of each IDE drive, the physical drives are located into sockets substantially similar to those found on an IDE bus of a standard computer system.

RAID calculations are performed within the device itself, using conventional hardware RAID circuitry mounted on circuit board 412, having electrical connections to the back plane circuit board 413. Right extrusion 402 defines a cavity 414, configured to receive circuit board 412. The extrusions 401 and 402 are held in position by an upper plate 415 and a lower plate 416, secured by appropriate bolts 417.

The rear face of back plane 413 is illustrated in *Figure 5*. The back plane includes a conventional SCSI socket 501 and a power supply socket 502. The array therefore presents itself to the main system as a single disk drive, requiring a single disk drive connection via SCSI interface 501.

Back plane 413 also includes rows of holes 503 to facilitate ventilation of the disks. Thus, cooling air is brought in through ventilation holes 405, blown between the disks 301, 302 and 303 and then exits through holes 503.

The circuit implemented on board 412 is illustrated diagrammatically in *Figure 6*. The circuit includes a central processing unit 601 which communicates with an input/output circuit 602 via a CPU bridge 603. In addition, operation of CPU 601 is controlled by a CPU mode select circuit 604. Power from the housing is directed to a three volt supply regulating circuit 605, arranged to supply power to operational circuits via supply rails.

The CPU 601 receives data relating to the operational environment from an environmental detecting circuit 606. This information may be received directly, as shown in *Figure 6*, or it may be directed via other control circuitry to allow combined environmental information to be returned to the CPU 601.

Further output circuitry includes IDE controllers **607** and **608** and a SCSI controller **609**. These circuits communicate with the back plane sockets via a one hundred and eighty way connector **610**.

5 Input/output circuit **602** supplies driving current to six LED's **701**, **702**, **703**, **704**, **705** and **706** shown in *Figure 7*. Each of these LED's is visible by means of respective holes **711**, **712**, **713**, **714**, **715** and **716** in the front panel **404**. Each LED is a Hewlett Packard HSMF-C655 and actually includes a green LED and a red LED which may be operated independently.

10 LED **701** indicates the overall operational integrity of the system and primarily confirms that CPU **601** is operating correctly. Thus, when the system is fully operational, LED **701** is illuminated green. Alternatively, if faults have been detected within the controller, LED **701** is illuminated red.

15 LED **702** represents the environmental monitoring status and is primarily concerned with operational temperature. Environmental circuit **606** includes a temperature sensor and a fault condition is generated if this sensor detects that operational temperatures have become excessive. In addition, a tachometer is associated with fan **403** and a fault condition is generated if this detects that rotation of the fan has ceased. Malfunction of fan **403** represents a serious problem in that this could result in all three
20 drives being permanently damaged such that no protection is offered by the RAID configuration. The system also detects the presence of appropriate voltages on voltage supply rails, as supplied by power supply unit **605** in addition to detecting appropriate terminator power on the SCSI bus.

25 When the supply rail voltages are correct, SCSI terminator power is correct, the fan is operational and the system is working at its optimal operational temperature, LED **702** is illuminated green. If the system encounters problems and diverges from its preferred operational characteristics, such a condition is detected and LED **702** is illuminated orange. Under these conditions, further operation of the system is permitted
30 but warnings may be generated to the effect that a job should be closed

down and that the device should be investigated. If problems continue and the situation worsens, particularly if the operational temperature becomes very high, LED 702 is illuminated red. Under these conditions, power to the drives is removed and an error condition is generated such that further access to the drives is not permitted.

LED 703 indicates that the SCSI connection is fully operational by being illuminated green. Furthermore, when the SCSI bus is actually in use, LED 703 is illuminated orange.

LED's 704, 705 and 706 represents operational characteristics of the individual drives 301, 302 and 303 respectively. When the drives are operational, the LED's are illuminated green and then illuminated orange when the actual data transfer takes place. Furthermore, if a disk error is detected, to the effect that an individual disk has failed, its respective LED is illuminated red.

In response to a single disk failure, it is preferable for the system to be placed off-line and for the damaged disk to be replaced immediately so that the lost data may be reconstituted and the system returned to protected mode operation. In order to replace a disk, the front panel is removed, an operation facilitated by the front panel 404 being retained simply to the main housing by means of an interference connection. Having removed the front panel 404 it is restrained by wires 717 required for supplying electrical power to fan 403.

The disk drives include tapped holes towards their front-right corner and each of said tapped holes receives a threaded stud 719. Stud 719 allows its respective disk 301 to 303 to be removed by the application of a stud hook 720. Force is applied in the direction of arrow 721, thereby forcing the respective disk drive away from its IDE and data sockets, such as sockets 406 and 409 etc.

An alternative embodiment is illustrated in *Figure 8*. In this embodiment, side panels and a base panel are fabricated as a single

extrusion **801**. The housing is then completed by the application of a top panel **802**. The top panel **802** is secured to the lower extrusion **801** by means of bolts **803** and circuitry held within the extrusion is further secured by an adhesive clip **804**.

Claims

1. A plurality of data storage devices configured to store machine readable data in a protected way such that data is recoverable in the event of a single device failure, wherein
5 the devices are housed for application directly into an existing disk bay for a computer;
the devices are connectable to a disk interface as if they were a single conventional storage volume; and
10 said devices are controlled by an operating system installed on a computer as if they were a single storage volume.
2. Data storage devices according to claim 1, wherein said storage devices are magnetic disk drives.
15
3. Data storage devices according to claim 2, wherein the magnetic disks are interfaced to an IDE connection.
4. Data storage devices according to claim 3, wherein three disks
20 are received in respective IDE connections.
5. Data storage devices according to any of claims 1 to 3, wherein said devices present a SCSI interface to a host computer.
- 25 6. Data storage device according to any of claims 1 to 5, configured to be housed in two or more five and one quarter inch drive bays.
7. Data storage devices according to any of claims 1 to 6, including means for detecting when said devices are operating in non-ideal
30 conditions.

8. Data storage devices according to claim 7, including means for detecting when said devices are operating at excessive temperatures.

5 9. Data storage devices according to claim 7 or claim 8, including means for detecting non-operation of a cooling fan.

10 10. Data storage devices according to claim 7 or claim 8, including means for directly detecting an excessive operational temperature.

11. Data storage devices according to any of claims 7 to 10, including means for removing drive power to said devices upon detecting a non-ideal operating condition.

15 12. Data storage devices according to any of claims 1 to 11, including a detachable front panel and a cooling fan secured to said front panel, including ventilation openings arranged to direct a cooling air-stream between the individual devices.

20 13. A plurality of data storage devices according to any of claims 1 to 12, wherein said devices are connectable in a computer housing and the devices are controlled by the operating system of said computer.

25 14. A method of equipping a personal computer with a plurality of data storage devices configured as a redundant array by interfacing said devices to conventional five and one quarter inch drive bays, such that protected machine readable data is recoverable in the event of a single disk failure, comprising the steps of

supporting the array within an existing disk bay for a computer,

connecting the array to the computer as if it were a single conventional computer disk; and

controlling said drives by an operating system installed on a computer as if it were a single storage volume.

5

15. A method according to claim 14, wherein said data storage devices are magnetic disk drives.

10

16. A method according to claim 15, wherein said magnetic disk drives are interfaced to an IDE connection.

17. A method according to claim 16, wherein three disks are received in respective IDE connections.

15

18. A method according to any of claims 14 to 17, wherein said devices present a SCSI interface to a host computer.

19. A method according to any of claims 14 to 18, wherein said devices are housed in two or more five and one quarter inch drive bays.

20

20. A method according to any of claims 14 to 19, wherein non-ideal operating conditions for said devices are detected.

25

21. A plurality of data storage devices substantially as herein described with reference to the accompanying Figures.

22. A method of equipping a personal computer substantially as herein described with reference to the accompanying Figures.



Application No: GB 9820213.8
Claims searched: 1 to 22

Examiner: Julyan Elbro
Date of search: 4 January 1999

**Patents Act 1977
Search Report under Section 17**

Databases searched:

UK Patent Office collections, including GB, EP, WO & US patent specifications, in:
UK CI (Ed.Q): G5R (RGB, RB33, RAC); G4A (AES)
Int CI (Ed.6): G06F 11/10; G11B 20/18
Other: EDOC WPI

Documents considered to be relevant:

Category	Identity of document and relevant passage	Relevant to claims
X	EP 0795812 A1 HITACHI see figure 1 and pages 2-3.	1-20
X	EP 0717357 A2 SYMBIOSIS LOGIC see abstract and figure 2.	1-20
X	EP 0569313 A2 INTERNATIONAL BUSINESS MACHINES see abstract and figures 1 and 3.	1-20
X	EP 0569236 A2 COMPAQ see figure 2 and pages 2-4.	1-20
X	EP 0485110 A2 ARRAY TECHNOLOGY see abstract.	1-20
X	EP 0450801 A2 INTERNATIONAL BUSINESS MACHINES see abstract, column 22 line 34 to column 23 line 11, and column 27 lines 15-25.	1-20
X	WO 93/18455 A1 ARRAY TECHNOLOGY see abstract, figure 1, and page 10 lines 2-26.	1-20
X	WO 91/20076 A1 STORAGE TECHNOLOGY see abstract and figure 1.	1-20
X	WO 91/14982 A1 SF2 CORPORATION see abstract and figures 1 and 2.	1-20

X	Document indicating lack of novelty or inventive step	A	Document indicating technological background and/or state of the art.
Y	Document indicating lack of inventive step if combined with one or more other documents of same category.	P	Document published on or after the declared priority date but before the filing date of this invention.
&	Member of the same patent family	E	Patent document published on or after, but with priority date earlier than, the filing date of this application.

An Executive Agency of the Department of Trade and Industry



The
Patent
Office
13



INVESTOR IN PEOPLE

Application No: GB 9820213.8
Claims searched: 1 to 22

Examiner: Julyan Elbro
Date of search: 4 January 1999

Category	Identity of document and relevant passage	Relevant to claims
X	US 5651132 A HITACHI see abstract and figure 1.	1-20

X	Document indicating lack of novelty or inventive step	A	Document indicating technological background and/or state of the art.
Y	Document indicating lack of inventive step if combined with one or more other documents of same category.	P	Document published on or after the declared priority date but before the filing date of this invention.
&	Member of the same patent family	E	Patent documents published on or after, but with priority date earlier than, the filing date of this application.

An Executive Agency of the Department of Trade and Industry

158

JP1994301607A

1994-10-28

Bibliographic Fields

Document Identity

(19)【発行国】
日本国特許庁 (JP)
(12)【公報種別】
公開特許公報 (A)
(11)【公開番号】
特開平6-301607
(43)【公開日】
平成6年(1994)10月28日

(19) [Publication Office]
Japan Patent Office (JP)
(12) [Kind of Document]
Unexamined Patent Publication (A)
(11) [Publication Number of Unexamined Application]
Japan Unexamined Patent Publication Hei 6- 301607
(43) [Publication Date of Unexamined Application]
1994 (1994) October 28*

Public Availability

(43)【公開日】
平成6年(1994)10月28日

(43) [Publication Date of Unexamined Application]
1994 (1994) October 28*

Technical

(54)【発明の名称】
マルチアクセスI/O制御方式
(51)【国際特許分類第5版】
G06F 13/00 351 B 7368-5B
13/12 340 F 8133-5B
【請求項の数】
5
【出願形態】
OL
【全頁数】
10

(54) [Title of Invention]
MULTI ACCESS I/O CONTROL SYSTEM
(51) [International Patent Classification, 5th Edition]
G06F 13/00 351 B 7368-5B
13/12 340 F 8133-5B
[Number of Claims]
5
[Form of Application]
OL
[Number of Pages in Document]
10

Filing

【審査請求】
未請求
(21)【出願番号】
特願平5-86000
(22)【出願日】
平成5年(1993)4月13日

[Request for Examination]
Unrequested
(21) [Application Number]
Japan Patent Application Hei 5- 86000
(22) [Application Date]
1993 (1993) April 13*

Parties

Applicants

(71)【出願人】

(71) [Applicant]

JP1994301607A

1994-10-28

【識別番号】

000005108

【氏名又は名称】

株式会社日立製作所

【住所又は居所】

東京都千代田区神田駿河台四丁目6番地

Inventors

(72)【発明者】

【氏名】

宇賀神 敦

【住所又は居所】

神奈川県海老名市下今泉810番地 日立製作所 オフィスシステム事業部内

Agents

(74)【代理人】

【弁理士】

【氏名又は名称】

鈴木 誠

Abstract

(57)【要約】

【目的】

複数の情報処理装置から複数の I/O デバイスへのアクセスを可能とする。

【構成】

複数の情報処理装置 20,30,40 とマルチアクセス制御装置 50 を FDDI10 に接続し、マルチアクセス制御装置 50 は、I/O デバイス 70,80,90 に SCSI 接続されている。

情報処理装置は、マルチアクセス制御装置へ FDDI フレームでアクセスする。

ネットワーク制御部 500 は、情報処理装置からのデータを FDDI インタフェースで送受信した後、プロトコル変換部 520 では、SCSI プロトコルに変換し、I/O デバイス制御部 510 を介して I/O デバイスをアクセスする。

[Identification Number]

000005108

[Name]

HITACHI LTD. (DB 69-054-1503)

[Address]

Tokyo Chiyoda-ku Kanda Surugadai 4-Chome 6

(72) [Inventor]

[Name]

*** Atsushi

[Address]

Kanagawa Prefecture Ebina City Shimoimaizumi 810address Hitachi office systems department *

(74) [Attorney(s) Representing All Applicants]

[Patent Attorney]

[Name]

Suzuki *

(57) [Abstract]

[Objective]

access to I/O device of plural is made possible from information processing apparatus of plural .

[Constitution]

information processing apparatus 20, 30, 40 and multi access control device 50 of plural are connected to FDDI10, the multi access control device 50 SCSI is connected to I/O device 70, 80, 90.

To multi access control device access it does information processing apparatus , with FDDIframe .

data from information processing apparatus transmission and reception after doing, in protocol conversion section 520,it converts network control unit 500, to SCSI protocol with FDDIinterface , through I/O device control unit 510,access it does I/O device . .

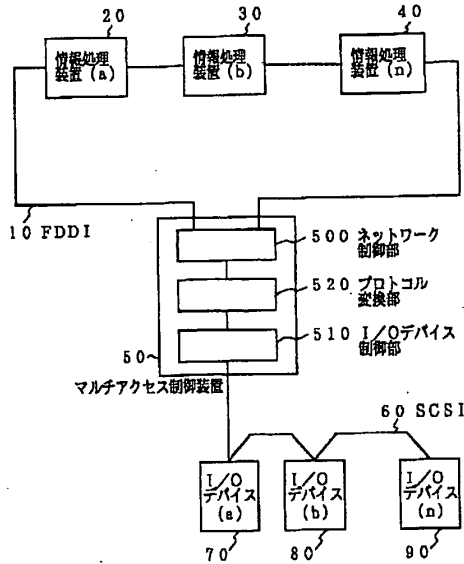

Claims

【特許請求の範囲】

【請求項 1】

ネットワークを介して複数の情報処理装置を接続したシステムにおいて、該ネットワークのインタフェース制御を行うネットワーク制御手段と、I/Oインタフェースを介して複数のI/Oデバイスを制御するI/Oデバイス制御手段と、該ネットワーク制御手段とI/Oデバイス制御手段のインタフェース変換を行うプロトコル変換手段からなるマルチアクセス制御手段を設け、前記複数の情報処理装置は該マルチアクセス制御手段を介して前記複数のI/Oデバイスにアクセスすることを特徴とするマルチアクセスI/O制御方式。

【請求項 2】

前記I/Oデバイス制御手段を前記I/Oデバイス内の制御部に内蔵することを特徴とする請求項1記載のマルチアクセスI/O制御方式。

【請求項 3】

前記複数の情報処理装置が実行した処理データを、前記マルチアクセス制御手段を介して前記所定のI/Oデバイスに格納し、該情報処理装置の障害発生時に予備の情報処理装置に切り

[Claim(s)]

[Claim 1]

Through network, through network control means and I/O interface which do interface control of said network in system which connects information processing apparatus of plural, the multi access control means which consists of protocol conversion means which converts I/O device control means and the said network control means and I/O device control means which control I/O device of plural interface providing, As for information processing apparatus of aforementioned plural through said multi access control means, in the I/O device of aforementioned plural access multi access I/O control system . which designates that it does as feature

[Claim 2]

multi access I/O control system . which is stated in Claim 1 which designates that theaforementioned I/O device control means is built in to control unit inside theaforementioned I/O device as feature

[Claim 3]

Treatment data which information processing apparatus of aforementioned plural executed, through aforementioned multi access control means , it houses in theaforementioned predetermined I/O device , changes to information processing

替え、該予備の情報処理装置は、前記処理データが格納された I/O デバイスを参照して処理を継続することを特徴とする請求項 1 記載のマルチアクセス I/O 制御方式。

【請求項 4】

前記各情報処理装置は、ローカル I/O デバイスを有し、該ローカル I/O デバイ스에記録される情報を、前記マルチアクセス制御手段を介して、前記情報処理装置に対応する I/O デバイ스에格納してバックアップすることを特徴とする請求項 1 記載のマルチアクセス I/O 制御方式。

【請求項 5】

前記 I/O インタフェースは、送信専用のインタフェースと受信専用のインタフェースから構成されていることを特徴とする請求項 1 記載のマルチアクセス I/O 制御方式。

Specification

【発明の詳細な説明】

【0001】

【産業上の利用分野】

本発明は、マルチアクセス I/O 制御方式に関し、特にネットワークを介して複数の情報処理装置を接続したシステムにおいて、複数の情報処理装置からアクセス可能な I/O デバイスの制御方式に関する。

【0002】

【従来の技術】

I/O デバイスを複数の処理装置によって共用する技術として、例えば、特開平 4-196737 号公報に記載された方式がある。

この方式においては、1 台の保守用コンソールを複数台のホストコンピュータで共有するもので、ホストコンピュータからの受信データをバッファリングした後、コントロールユニットに通知し、該コントロールユニットはホスト選択用のスイッチを設定し、選択されたホストのデータを保守用コンソールに出力する。

【0003】

【発明が解決しようとする課題】

しかしながら、上記した技術は、各ホストインタフェース毎に独立にバッファを設けているので、ハ

apparatus of preparatory at time of damage of said information processing apparatus , as for information processing apparatus of said preparatory , referring to I/O device where aforementioned treatment data is housed, the multi access I/O control system . which it states in Claim 1 which designates that it continued treatment as feature

[Claim 4]

information which aforementioned each information processing apparatus , possesses local I/O device , is recorded to said local I/O device , through aforementioned multi access control means , housing in I/O device which corresponds to aforementioned information processing apparatus , backup the multi access I/O control system . which is stated in Claim 1 , which designates thing which is done as feature

[Claim 5]

As for aforementioned I/O interface , from interface of transmission dedicated and interface of reception dedicated configuration multi access I/O control system . which is stated in Claim 1 which designates that it is done as feature

[Description of the Invention]

【0001】

[Field of Industrial Application]

this invention regards multi access I/O control system , through especially network , from the information processing apparatus of plural it regards control system of accessible I/O device in system which connects information processing apparatus of plural .

【0002】

[Prior Art]

There is a system which is stated in for example Japan Unexamined Patent Publication Hei 4- 196737 disclosure as technology which shares I/O device with processing unit of plural .

Regarding this system , being something which shares console for the conservation of 1 with host computer of plural table , buffering after doing , it notifies received information from host computer to control unit , said control unit sets the Switch for host selection , outputs data of host which is selected to console for conservation .

【0003】

[Problems to be Solved by the Invention]

But, because technology which was inscribed in each every host interface has provided buffer in independence, amount of

ードウェア量が多くなり、また、ホスト選択スイッチのような固有のハードウェアを必要とし、さらに、ホスト数に相当する数のホストインタフェースコネクタを必要とするので、接続するホストが多くなると装置全体が大型化するとともに、複数台のホストに対して1台のコンソールを接続した構成しか採ることができないという欠点があった。

[0004]

本発明の目的は、複数の情報処理装置から複数の I/O デバイスへのアクセスを可能とするマルチアクセス I/O 制御方式を提供することにある。

[0005]

【課題を解決するための手段】

前記目的を達成するために、請求項1記載の発明では、ネットワークを介して複数の情報処理装置を接続したシステムにおいて、該ネットワークのインタフェース制御を行うネットワーク制御手段と、I/O インタフェースを介して複数の I/O デバイスを制御する I/O デバイス制御手段と、該ネットワーク制御手段と I/O デバイス制御手段のインタフェース変換を行うプロトコル変換手段からなるマルチアクセス制御手段を設け、前記複数の情報処理装置は該マルチアクセス制御手段を介して前記複数の I/O デバイスにアクセスすることを特徴としている。

[0006]

請求項2記載の発明では、前記 I/O デバイス制御手段を前記 I/O デバイス内の制御部に内蔵することを特徴としている。

[0007]

請求項3記載の発明では、前記複数の情報処理装置が実行した処理データを、前記マルチアクセス制御手段を介して前記所定の I/O デバイスに格納し、該情報処理装置の障害発生時に予備の情報処理装置に切り替え、該予備の情報処理装置は、前記処理データが格納された I/O デバイスを参照して処理を継続することを特徴としている。

[0008]

請求項4記載の発明では、前記各情報処理装置は、ローカル I/O デバイスを有し、該ローカル I/O デバイスに記録される情報を、前記マルチアクセス制御手段を介して、前記情報処理装置に

hardware to become many, in addition, to need hardware of peculiar like host selection switch, because furthermore, host interface connector of a quantity which is suitable to quantity of host are needed, when host which is connected becomes many as device entirety does scale-up, There was a deficiency that only configuration which connects console of 1 vis-a-vis host of plural table it is possible to take.

[0004]

objective of this invention is to offer multi access I/O control system which makes access to I/O device of plural possible from information processing apparatus of plural.

[0005]

[Means to Solve the Problems]

In order to achieve aforementioned objective, with invention which is stated in Claim 1, through network, through network control means and the I/O interface which do interface control of said network in system which connects the information processing apparatus of plural, multi access control means which consists of protocol conversion means which converts I/O device control means and said network control means and I/O device control means which control I/O device of plural interface providing, information processing apparatus of aforementioned plural through said multi access control means, has designated that access it does as feature in I/O device of the aforementioned plural.

[0006]

With invention which is stated in Claim 2, it designates that aforementioned I/O device control means is built in to control unit inside the aforementioned I/O device as feature.

[0007]

With invention which is stated in Claim 3, treatment data which information processing apparatus of aforementioned plural executed, through the aforementioned multi access control means, it houses in aforementioned predetermined I/O device, changes to information processing apparatus of preparatory at time of damage of said information processing apparatus, the information processing apparatus of said preparatory referring to I/O device where aforementioned treatment data is housed, has designated that it continues treatment as feature.

[0008]

With invention which is stated in Claim 4, aforementioned each information processing apparatus, it possesses local I/O device, information which is recorded to the said local I/O device, through aforementioned multi

対応する I/O デバイスに格納してバックアップすることを特徴としている。

[0009]

請求項 5 記載の発明では、前記 I/O インタフェースは、送信専用のインタフェースと受信専用のインタフェースから構成されていることを特徴としている。

[0010]

[作用]

複数の情報処理装置とマルチアクセス制御装置が FDDI に接続され、マルチアクセス制御装置は、I/O デバイスに SCSI 接続されている。

マルチアクセス制御装置は、ネットワーク制御部とプロトコル変換部と I/O デバイス制御部から構成されている。

情報処理装置は、マルチアクセス制御装置へ FDDI フレームでアクセスする。

ネットワーク制御部は、情報処理装置からのデータを FDDI インタフェースで送受信した後、プロトコル変換部では、SCSI プロトコルに変換し、I/O デバイス制御部を介して I/O デバイスをアクセスする。

これにより、従来の I/O デバイスに何ら変更を加えることなく、マルチアクセス制御装置を付加するのみで、複数の情報処理装置から複数の I/O デバイスを制御することができる。

[0011]

[実施例]

以下、本発明の一実施例を図面を用いて具体的に説明する。

図 1 は、本発明の一実施例に係るシステム構成図である。

本発明のシステムは、複数の情報処理装置 20、30、40 とマルチアクセス制御装置 50 が FDDI(Fiber Distributed Data Interface)10(LAN) に接続されて構成されている。

[0012]

FDDI10 に接続された情報処理装置 20、30、40 は、マルチアクセス制御装置 50 へ FDDI フレームでアクセスする。

マルチアクセス制御装置 50 は、FDDI インタフェース制御を行うネットワーク制御部 500 と、

access control means, housing in I/O device which corresponds to aforementioned information processing apparatus, it designates that backup it does as feature.

[0009]

With invention which is stated in Claim 5, as for the aforementioned I/O interface, it designates that configuration it is done as feature from interface of transmission dedicated and interface of the reception dedicated.

[0010]

[Working Principle]

information processing apparatus and multi access control device of plural are connected by FDDI, the multi access control device SCSI is connected to I/O device.

multi access control device configuration is done from network control unit and protocol conversion section and I/O device control unit.

To multi access control device access it does information processing apparatus, with FDDI frame.

data from information processing apparatus transmission and reception after doing, in protocol conversion section, it converts network control unit, to SCSI protocol with FDDI interface, through I/O device control unit, access it does I/O device.

Because of this, multi access control device is added only, can control I/O device of the plural from information processing apparatus of plural without adding what modification to conventional I/O device.

[0011]

[Working Example(s)]

Below, one Working Example of this invention is explained concretely making use of drawing.

Figure 1 is system diagram which relates to one Working Example of this invention.

system of this invention is done, information processing apparatus 20, 30, 40 and multi access control device 50 of plural FDDI (Fiber Distributed data interface) being connected by 10 (LAN), configuration.

[0012]

To multi access control device 50 access it does information processing apparatus 20, 30, 40 which is connected to the FDDI10, with FDDI frame.

multi access control device 50 configuration is done from protocol conversion section 520 which converts I/O device

SCSI60 に接続されている I/O デバイス 70,80,90(例えば、ハードディスクなどの記憶媒体や回線などの通信手段)の制御を行う I/O デバイス制御部 510 と、FDDI プロトコル及び SCSI プロトコルのインタフェース変換を行うプロトコル変換部 520 から構成されている。

【0013】

図 2 は、マルチアクセス制御装置 50 のブロック構成図である。

マルチアクセス制御装置 50 において、ネットワーク制御部 500 と、I/O デバイス制御部 510 と、RAM523 と、アクセス制御部 524 は I/O バス 525 によって接続され、プロセッサ 521 と、ROM522 と、アクセス制御部 524 はプロセッサバス 526 によって接続されている。

【0014】

プロトコル変換を行うためのプログラムは、ROM522 に格納され、プロセッサ 521 上で動作する。

本実施例では、I/O バス 525 の使用率を下げるためにプロセッサバス 526 を設けているが、情報処理装置 20、30、40 からのアクセス頻度が低い場合には、I/O バスとプロセッサバスを同一バスにして構成してもよい。

【0015】

アクセス制御部 524 は、ネットワーク制御部 500 または I/O デバイス制御部 510 からプロセッサ 521 への割込み制御を行うと共にプロセッサ 521 から RAM523、ネットワーク制御部 500、I/O デバイス制御部 510 へのアクセス制御並びにネットワーク制御部 500、I/O デバイス制御部 510 から RAM523 へのアクセス制御を行っている。

【0016】

ROM522 には、プログラムの他に FDDI の MAC(Media Access Control)アドレスを格納する。

RAM523 は、データ送信及び受信のバッファとして使用するほかに、ネットワーク制御部 500、I/O デバイス制御部 510 への制御を行うためのディスクリプタ領域として使用する。

また、マルチアクセス制御装置内のステータス管理や I/O デバイス毎の管理等のためにテーブルとして使用する。

【0017】

図 3 は、情報処理装置からマルチアクセス制御装置への制御フレームのフォーマットを示す図

control unit 510 and FDDI protocol and SCSI protocol which control I/O device 70, 80, 90 (for example hard disk or other storage media and circuit or other communication means) which is connected to network control unit 500 and SCSI 60 which do FDDI interface control interface .

【0013】

Figure 2 is block diagram of multi access control device 50.

In multi access control device 50, network control unit 500 and I/O device control unit 510 and RAM 523 and access control section 524 are connected with I/O bus 525, processor 521 and ROM 522 and access control section 524 are connected with processor bus 526.

【0014】

program in order to do protocol conversion is housed in ROM 522, operates on processor 521.

With this working example, processor bus 526 is provided in order to lower usage of I/O bus 525, but when access frequency from information processing apparatus 20, 30, 40 is low, configuration it is possible to do with I/O bus and processor bus as same bus .

【0015】

access control section 524, as interruption control to processor 521 is done from network control unit 500 or I/O device control unit 510, from processor 521 does access control to RAM 523 from access control and network control unit 500, I/O device control unit 510 to RAM 523, network control unit 500, I/O device control unit 510.

【0016】

In ROM 522, MAC (Media access control) address of FDDI is housed to other than program .

Besides you use as buffer for data transmission and reception, you use RAM 523, as [disukuriputa] region in order to control to network control unit 500, I/O device control unit 510.

In addition, you use management or other for every status management and I/O device inside multi access control device as table .

【0017】

Figure 3 is figure which shows format of control frame to multi access control device from information processing

である。

図3において、FDDIヘッダ100(ANSI標準)にSNAPヘッダ110、IPヘッダ120、TCPヘッダ130(全てRequest For Commentで規定されている)、データ140を付加し制御を行う。

[0018]

情報処理装置20,30,40とマルチアクセス制御装置50との間の送達確認及び順序制御は、TCP(Transmission Control Protocol)により行う。

[0019]

データ140は、制御ブロック1410、1450と送信I/Oデータ1460から構成されていて、制御ブロックは、1乃至複数のブロックからなる。

また、送信I/Oデータ1460は付加してもよいし、あるいは付加しなくてもよいが、最大フレーム長は、FDDI規格に準拠する必要がある。

[0020]

制御ブロック1410、1450は28バイトから構成される。

制御ブロック1410において、制御ブロック長1411は、2バイトのフィールドであり、制御ブロックの総バイト長を示す。

コマンドチェインビット1412は、1ビットからなり、異なるコマンドの制御ブロックが連続しているか否かを示す。

"0"の時はコマンドチェインなし、"1"の時はコマンドチェインありを示す。

[0021]

デバイスID1413は、2バイトのフィールドであり、SCSI_ID 4ビット、LUN(Logical Unit Number) 4ビット、拡張LUN 8ビットから構成される。

CDBフォーマット1414は、5ビットのフィールドである。

CDBは、6バイト、10バイト、12バイトがあるのでその種別を示している。

"0"が6バイト、"1"が10バイト、"2"が12バイトを示す。

[0022]

不正長抑止ビット1415は、1ビットのフィールドである。

リード要求と実際の読みだしデータ長が異なってもエラー報告しないためのビットである。

apparatus .

In Figure 3, SNAPheader 110, IP header 120, TCP header 130 (Being stipulated with all Request For Comment, it is), it adds data 140 to FDDIheader 100 (ANSI standard) and controls.

[0018]

It does sending verification and order control between information processing apparatus 20, 30, 40 and multi access control device 50, with TCP (transmission Control protocol).

[0019]

As for data 140, configuration being done from control block 1410, 1450 and the transmission I/O data 1460, as for control block, it consists of block of 1 to plural.

In addition, it is possible to add transmission I/O data 1460 it is not necessary, and, or to add, but maximum frame length has necessity to conform to FDDI standard.

[0020]

control block 1410, 1450 configuration is done from 28 byte.

In control block 1410, control block length 1411, with field of 2 byte, shows the entire byte length of control block.

command chain bit 1412 consists of 1 bit, shows whether or not which control block of the different command is continual.

When "0" being, there is a command chain and shows time of command chain none, "1" shows time of command chain.

[0021]

device ID1413, with field of 2 byte, SCSI_ID 4bit, LUN (Logical Unit Number) configuration is done from 4 bit, extended LUN 8bit.

CDB format 1414 is field of 5 bit.

Because CDB are 6 byte, 10 byte, 12 byte, type has been shown.

"0" 6 byte, "1" 10 byte, "2" 12 byte are shown.

[0022]

Illegitimate long control bit 1415 is field of 1 bit.

read request and actual it starts reading and data length differs and error it is a bit because it does not report.

"1"のときエラー報告せず、"0"のときエラー報告する。

【0023】

終了報告ビット1416は、1ビットのフィールドである。

"1"のとき処理終了を終了報告ブロック(図 4)で報告する。

"0"の時は報告しない。

【0024】

コマンド 1421 は、8 ビットのフィールドである。

データ受信、データ送信、マルチアクセス制御装置 50 に対する指示などを示す。

SCSI NO.1422 は、8 ビットのフィールドである。

マルチアクセス制御装置 50 内で複数の SCSI を制御する場合に、どの SCSI かを識別するための情報である。

シーケンス NO.1420 は、16 ビットのフィールドである。

情報処理装置 20,30,40 からの要求とマルチアクセス制御装置 50 からの終了報告を対応させるための情報である。

【0025】

データカウンタ 1418 は、4 バイトのフィールドであり、送信または受信するデータ長を示す。

CDB1419 は、本実施例では 10 バイトであり、SCSI 規格に準拠した CDB を格納する。

【0026】

図 4 は、マルチアクセス制御装置から情報処理装置への終了フレームのフォーマットを示す図である。

図において、FDDI ヘッダ 100、SNAP ヘッダ 110、IP ヘッダ 120、TCP ヘッダ 130 は、前述したものと同様である。

データ 140 は、終了報告ブロック 1470 と受信 I/O データ 1480 から構成されている。

【0027】

終了報告ブロック 1470 は、16 バイトから構成されている。

終了報告ブロック長 1471 は、16 ビットのフィールドであり、終了報告ブロックの総バイト数を示す。

終了報告チェインビット 1472 は、1 ビットのフィールドであり、終了報告が複数ある場合に"1"を

" At time of 1 '' error it does not report, " when 0 "being, error it reports.

[0023]

End report bit 1416 is field of 1 bit .

" At time of 1 '' treatment end is reported with endreport block (Figure 4).

When " 0 " being, it does not report.

[0024]

command 1421 is field of 8 bit .

data reception , data transmission and indication etc for multi access control device 50 are shown.

SCSI NO.1422 is field of 8 bit .

When SCSI of plural is controlled inside multi access control device 50, it is a information in order to identify which SCSI .

sequence NO.1420 is field of 16 bit .

It is a information because end report from multi access control device 50 it corresponds withrequest from information processing apparatus 20, 30, 40.

[0025]

data count 1418 with field of 4 byte , shows data length which ittransmits or receives, or.

CDB1419 with this working example with 10 byte , houses CDB whichconforms to SCSI standard .

[0026]

Figure 4 is figure which shows format of end frame to the information processing apparatus from multi access control device .

In figure, FDDIheader 100, SNAPheader 110 , IP header 120, TCP header 130 is similar to those which are mentionedearlier.

data 140 configuration is done from end report block 1470 and thereception I/O data 1480.

[0027]

End report block 1470 configuration is done from 16 byte .

End report block length 1471, with fee jpl 1 of 16 bit , shows theentire number of bytes of end report block .

End report chain bit 1472, when with field of 1 bit , end report is a plural , " sets 1 '' .

設定する。

【0028】

ステータス 1474 は、16 ビットのフィールドである。

このフィールドは、エラーの軽重を示すシビリティビット4ビット、エラーステータスフィールド12ビットから構成される。

SAVE DMA カウント 1473 は、4 バイトのフィールドであり、データカウント 1418 と実際に処理完了したバイト数の差分を示す。

例えば、データカウント 1418 が 1000 バイトで、実際に処理したデータが 1000 バイトの場合、該フィールドは、0 となる。

【0029】

図 5 は、情報処理装置 20、情報処理装置 30 からマルチアクセス制御装置 50 へのアクセスシーケンスを示す。

以下、情報処理装置から I/O デバイスへデータを書き込む場合の実施例の動作を説明する。

【0030】

情報処理装置 20 からマルチアクセス制御装置 50 へデータ書き込み指示を図 3 に示すフレームフォーマットで送信する。

ネットワーク制御部 500 はフレームを受信し、プロトコル変換部 520 から予め渡された RAM523 上のバッファにデータを格納する。

ネットワーク制御部 500 は、データ格納後、割込みをアクセス制御部 524 を介してプロセッサ 521 に通知する。

【0031】

情報処理装置 20 からのデータ書き込み指示の後、情報処理装置 30 からマルチアクセス制御装置 50 へ、データ書き込み指示を図 3 に示すフレームフォーマットで送信する。

ネットワーク制御部 500 はフレームを受信しプロトコル変換部 520 から予め渡された RAM523 上のバッファにデータを格納する。

ネットワーク制御部 500 は、データ格納後、割込みをアクセス制御部 524 を介してプロセッサ 521 に通知する。

但し、情報処理装置 20 からの処理が先であるのでその処理が終了するまで処理保留となる。

is a plural , " sets 1 '' .

[0028]

status 1474 is field of 16 bit .

this field shows light heavy of error , [shibiritibitto] configuration it is done from4 bit , error status field 12bit .

SAVE DMA count 1473, with field of 4 byte , shows difference of number of bytes which process end is done in data count 1418 and fact.

for example data count 1418 being 1000 byte , when data which was treated actualyis 1000 byte , said field becomes with 0.

[0029]

Figure 5 shows access sequence to multi access control device 50 from information processing apparatus 20, information processing apparatus 30.

Below, operation of Working Example when from information processing apparatus data is writtento I/O device is explained.

[0030]

From information processing apparatus 20 to multi access control device 50 it transmits with frame format which shows data writing indication in Figure 3 .

network control unit 500 receives frame , houses data in buffer on the RAM 523 which is beforehand transferred from protocol conversion section 520.

network control unit 500, after data storage , through access control section 524, notifies theinterruption to processor 521.

[0031]

After data writing indication from information processing apparatus 20, from information processing apparatus 30 to the multi access control device 50, it transmits with frame format which shows data writing indication in Figure 3 .

network control unit 500 receives frame and houses data in buffer on the RAM 523 which is beforehand transferred from protocol conversion section 520.

network control unit 500, after data storage , through access control section 524, notifies theinterruption to processor 521.

However, because treatment from information processing apparatus 20 is ahead, until thattreatment ends, it becomes treatment reservation .

【0032】

割り込みを受けたプロトコル変換部 520 は、受信したフレームのヘッダを解析し TCP、IP(Internet Protocol)処理を行う。

その後、制御ブロック 1410 を解析する。

フォーマットが正常ならば SCSI NO.1422、デバイス ID1413 が示す SCSI に対してコマンドを発行する。

コマンドの発行は、RAM523 上のディスクリプタに CDB を格納した後、I/O デバイス制御部 510 内のハードウェアレジスタに起動をかけることにより行う。

コマンドを受けた I/O デバイス制御部 510 は、SCSI 規格に従ってアービトレーション、セレクション、メッセージ、コマンドフェーズを遷移した後、情報処理装置 20 によって指定された例えば I/O デバイス 70 に対してデータ転送を行う。

【0033】

この時のデータ転送は、DMA(Direct Memory Access)で行う。

データ転送終了後、I/O デバイス 70 からステータ及びコマンドコンプリートが送られてくる。

これを受けた、I/O デバイス制御部 510 はプロセッサ 521 への割り込みをアクセス制御部 524 を介して通知する。

【0034】

割り込みを受けたプロセッサ 521 は、RAM523 に格納されているステータスを解析する。

その後、図 4 に示した終了報告ブロック、IP ヘッダ、TCP ヘッダ、SNAP ヘッダを RAM523 上に作成し、ネットワーク制御部 500 内のハードウェアレジスタに送信指示を書き込む。

これを受けたネットワーク制御部 500 は、FDDI プロトコルに従って終了報告を情報処理装置 20 に送信する。

【0035】

情報処理装置 20 の処理が終了後、情報処理装置 30 の処理を行う。

その動作は、前述した情報処理装置 20 の場合と同様であるので、説明は省略する。

【0036】

図 6 は、マルチアクセス制御装置と I/O デバイスを一体化させた場合の他の実施例の構成を示

【0032】

protocol conversion section 520 which receives interruption analyzes the header of frame which is received and does TCP , IP (internet protocol) treatment.

After that, control block 1410 is analyzed.

command is issued format vis-a-vis SCSI which normal mule SCSI NO.1422, device ID1413 shows.

It issues command , after housing CDB in [disukuriputa] on RAM 523,by making starting on hardware register inside I/O device control unit 510.

I/O device control unit 510 which receives command , following to SCSI standard , does the data transfer transition after doing arbitration , selection , message , command phase , vis-a-vis for example I/O device 70 which isappointed with information processing apparatus 20.

【0033】

It does data transfer at time of this , with DMA (direct memory access).

After data transfer ending, stator and [komandokonpuriito] are sent from I/O device 70.

This was received, I/O device control unit 510 through access control section 524, notifies theinterruption to processor 521.

【0034】

processor 521 which receives interruption analyzes status which is housed in RAM 523.

After that, end report block , IP header , TCP header , SNAPheader which is shown in Figure 4 is drawup on RAM 523, transmission indication is written to hardware register inside network control unit 500.

network control unit 500 which receives this, following to FDDIprotocol , transmits endreport to information processing apparatus 20.

【0035】

Treatment of information processing apparatus 20 after ending, treats information processing apparatus 30.

Because operation is similar to case of information processing apparatus 20 which ismentioned earlier, it abbreviates explanation.

【0036】

Figure 6 is figure which shows configuration of other Working Example when multi access control device and I/O

す図である。

すなわち、一体化によって、I/O デバイス内の制御部(SCSI コントローラ)が I/O デバイス制御部 510 を肩代わりし、従って、図 2 に示す I/O デバイス制御部 510 を設ける必要がなくなり、直接 I/O デバイス内の I/O 制御部 700 に制御ブロックを渡す処理方式を採ることになる。

[0037]

図 7 は、現用系情報処理装置から予備系情報処理装置への切替えを行う場合の他の実施例の構成を示す図である。

現用系情報処理装置 21,22 は、処理を実行する場合に、マルチアクセス制御装置 50 を介して、任意の I/O デバイス 70 内に引継ぎ情報 71 を格納処理する。

そして、現用系情報処理装置 21,22 に障害が発生したとき、予備系情報処理装置 23 は I/O デバイス 70 内の引継ぎ情報 71 を読み出して、処理を続行する。

[0038]

図 8 は、情報処理装置を I/O デバイスによってバックアップする場合の他の実施例の構成を示す図であり、各情報処理装置はローカル I/O デバイスを備えた構成を採っている。

[0039]

各情報処理装置 20,30,40 は、それぞれローカル I/O デバイス 201, 301, 401 にデータを書き出すとともに、情報処理装置 20 は、例えば I/O デバイス 70 に、情報処理装置 30 は I/O デバイス 80 に、情報処理装置 40 は I/O デバイス 90 にそれぞれデータを書き出し、データをバックアップする。

この書き出しは、前述した図 5 のシーケンスによって行う。

[0040]

図 9 は、マルチアクセス制御装置が 2 本の SCSI を制御する他の実施例の構成を示す。

この実施例では、一つのマルチアクセス制御装置から 2 本の SCSI を制御し、一方を送信専用とし、他方を受信専用としている。

[0041]

図において、SCSI コントローラ 511 は送信専用

device are unified.

With namely, unification, control unit (SCSI controller) inside I/O device shoulder doesto substitute I/O device control unit 510, therefore, necessity to provide I/O device control unit 510 which is shown in Figure 2 is gone, means to take treatment system whichdirectly transfers control block to I/O control unit 700 inside I/O device .

[0037]

Figure 7 is figure which shows configuration of other Working Example when changeover to preparatory information processing apparatus is done from current system information processing apparatus .

When treatment is executed, through multi access control device 50, it takes over the current system information processing apparatus 21, 22, inside I/O device 70 of option and it houses treats information 71.

When and, fault occurs in current system information processing apparatus 21, 22, preparatory information processing apparatus 23 takingover information 71 inside I/O device 70 reading *, continues treatment.

[0038]

As for Figure 8 , information processing apparatus in figure which shows configuration of theother Working Example when backup it does, as for each information processing apparatus configuration whichhas local I/O device is taken with I/O device .

[0039]

As for each information processing apparatus 20, 30, 40, as data is written out in respective local I/O device 201, 301, 401, as for information processing apparatus 20, in for example I/O device 70, as for information processing apparatus 30 in I/O device 80,information processing apparatus 40 it writes out data respectively in I/O device 90, data backup does.

It writes out this , with sequence of Figure 5 which is mentionedearlier.

[0040]

Figure 9 shows configuration of other Working Example where multi access control device controls SCSI of 2.

With this Working Example , it controls SCSI of 2 from multi access control device of the one , on one hand makes transmission dedicated , designates other as reception dedicated .

[0041]

In figure, as for SCSI controller 511 with transmission

であり、SCSI コントローラ 512 は受信専用である。

そして、I/O デバイス 70 への書き込みは SCSI コントローラ 511 を用い、I/O デバイス 70 からの読み出しは SCSI コントローラ 512 を用いる。

ただし、I/O デバイスに対するコマンドは送信受信にかかわらず全て SCSI コントローラ 511 で行う。

[0042]

本実施例の方式は、I/O デバイスが 1 台の場合に特に効果的である。

つまり、デバイスが 1 台に特定できるので、アービトラーション、セレクションを最初の 1 回のみ行い、その後のアクセス時にはアービトラーション、セレクションを省略することが出来る。

従って、SCSI のフェーズ遷移でコマンドコンプリート送信後、バスフリーすることなく、再びコマンドフェーズにすることができるので、高速なデータアクセスが可能となる。

[0043]

なお、本実施例は上記したもの他に、ブロードキャスト機能を用いることによって、複数の I/O デバイスに同一のデータを配布するように構成することができ、またネットワーク、インタフェースは上記した FDDI, SCSI に限定されず、他のネットワーク、インタフェースであってもよい。

[0044]

[発明の効果]

以上、説明したように、請求項 1 記載の発明によれば、ネットワーク制御手段と I/O デバイス制御手段とプロトコル変換手段からなるマルチアクセス制御手段を設けているので、I/O デバイスを変更することなく、複数の情報処理装置から複数の I/O デバイスへのアクセスが可能になる。

[0045]

請求項 2 記載の発明によれば、I/O デバイス制御部と I/O デバイス内の SCSI コントローラとを共用化しているので、装置構成を簡単化できる。

[0046]

請求項 3 記載の発明によれば、複数の情報処理装置が実行した処理データを I/O デバイスに格納しているので、障害発生時に高速に予備切替を行うことができる。

dedicated, as for SCSI controller 512 it is a reception dedicated.

And, it starts reading writing to I/O device 70 from I/O device 70 making use of SCSI controller 511, SCSI controller 512 uses.

However, command for I/O device does with all SCSI controller 511 regardless of transmit receive.

[0042]

system of this working example, when I/O device 1 is, especially effective.

In other words, because specific is possible device to 1, only the initial one time does arbitration, selection, after that it is possible at time of the access to abbreviate arbitration, selection.

Therefore, after [komandokonpuriito] transmitting, without BASF Lee doing with the phase transition of SCSI, because again it can make command phase, high speed data access becomes possible.

[0043]

Furthermore, this working example can do in order by fact that for other than those which were inscribed, broad cast function is used, distribution fabric to do same data to I/O device of plural, configuration, in addition network, interface is not limited in FDDI, SCSI which was inscribed, is good even with other network, interface.

[0044]

[Effects of the Invention]

As above, explained, according to invention which is stated in the Claim 1, because multi access control means which consists of network control means and I/O device control means and protocol conversion means is provided, from information processing apparatus of plural access to the I/O device of plural becomes possible without modifying I/O device.

[0045]

According to invention which is stated in Claim 2, because the SCSI controller inside I/O device control unit and I/O device is converted commonly, equipment configuration can be simplified.

[0046]

According to invention which is stated in Claim 3, because the treatment data which information processing apparatus of plural executed is housed in the I/O device, it is possible at time of damage to do preparatory changeover in the high

[0047]

請求項 4 記載の発明によれば、バックアップデータを一元管理することができ、特に DAT の如き着脱可能な I/O デバイスを用いた場合、I/O デバイス毎にバックアップする情報処理装置を特定することにより、メディア管理が容易になる。

[0048]

請求項 5 記載の発明によれば、SCSI を送信インタフェースと受信インタフェースに分離しているため、高スループットの I/O デバイスアクセスを実現することができる。

【図面の簡単な説明】

【図1】

本発明の一実施例に係るシステム構成図である。

【図2】

マルチアクセス制御装置のブロック構成図である。

【図3】

情報処理装置からマルチアクセス制御装置への制御フレームのフォーマットを示す図である。

【図4】

マルチアクセス制御装置から情報処理装置への終了フレームのフォーマットを示す図である。

【図5】

情報処理装置からマルチアクセス制御装置へのアクセスシーケンスを示す。

【図6】

マルチアクセス制御装置と I/O デバイスを一体化させた場合の他の実施例の構成である。

【図7】

現用系情報処理装置から予備系情報処理装置への切替えを行う場合の他の実施例の構成を示す図である。

【図8】

情報処理装置を I/O デバイスによってバックアップする場合の他の実施例の構成を示す図である。

speed .

[0047]

According to invention which is stated in Claim 4, it is possible to manage backup data monistically, when demountable I/O device like the especially DAT is used, media management becomes easy by specifying doing information processing apparatus which backup is done in every I/O device .

[0048]

According to invention which is stated in Claim 5, because the SCSI is separated into transmission interface and reception interface , I/O device access of high throughput can be actualized.

[Brief Explanation of the Drawing(s)]

[Figure 1]

It is a system diagram which relates to one Working Example of this invention .

[Figure 2]

It is a block diagram of multi access control device .

[Figure 3]

It is a figure which shows format of control frame to multi access control device from information processing apparatus .

[Figure 4]

It is a figure which shows format of end frame to information processing apparatus from multi access control device .

[Figure 5]

access sequence to multi access control device is shown from information processing apparatus .

[Figure 6]

It is a configuration of other Working Example when multi access control device and I/O device are unified.

[Figure 7]

It is a figure which shows configuration of other Working Example when changeover to preparatory information processing apparatus is done from current system information processing apparatus .

[Figure 8]

information processing apparatus it is a figure which shows configuration of other Working Example when backup it does with I/O device .

【図9】

マルチアクセス制御装置が2本のSCSIを制御する他の実施例の構成を示す図である。

【符号の説明】

10
FDDI
20
情報処理装置
30
情報処理装置
40
情報処理装置
50
マルチアクセス制御装置
500
ネットワーク制御部
510
I/O デバイス制御部
520
プロトコル変換部
60
SCSI
70
I/O デバイス
80
I/O デバイス
90
I/O デバイス

Drawings

【図1】

[Figure 9]

It is a figure which shows configuration of other Working Example where the multi access control device controls SCSI of 2.

[Explanation of Symbols in Drawings]

10
FDDI
20
information processing apparatus
30
information processing apparatus
40
information processing apparatus
50
multi access control device
500
network control unit
510
I/O device control unit
520
protocol conversion section
60
SCSI
70
I/O device
80
I/O device
90
I/O device

[Figure 1]

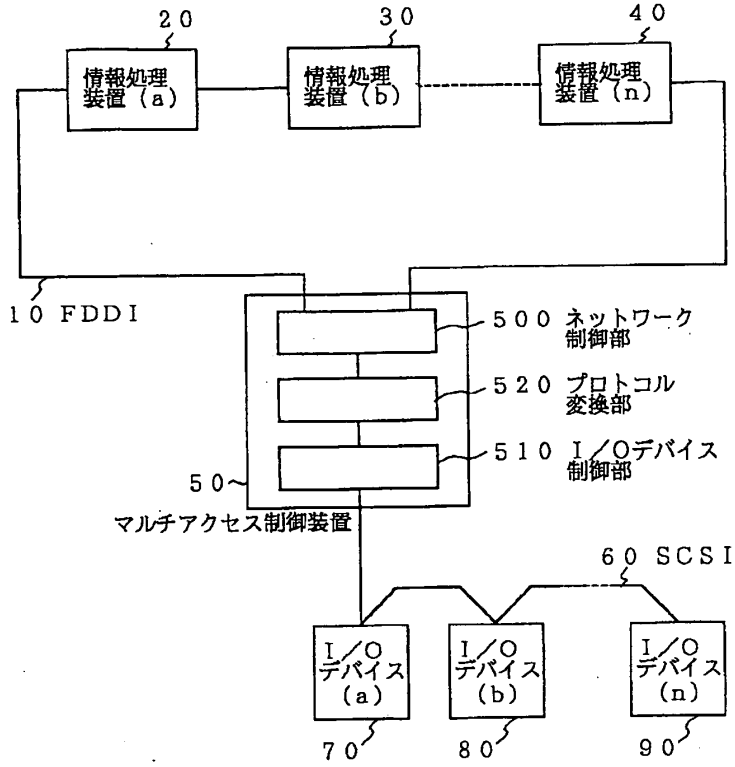

【図9】

[Figure 9]

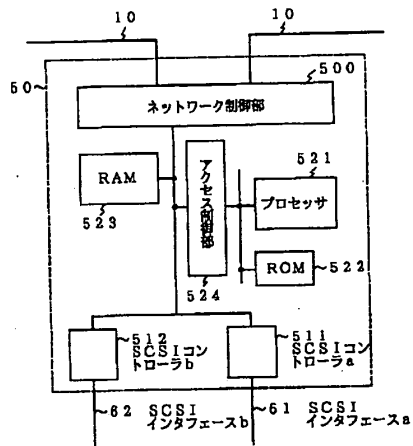

【図2】

[Figure 2]

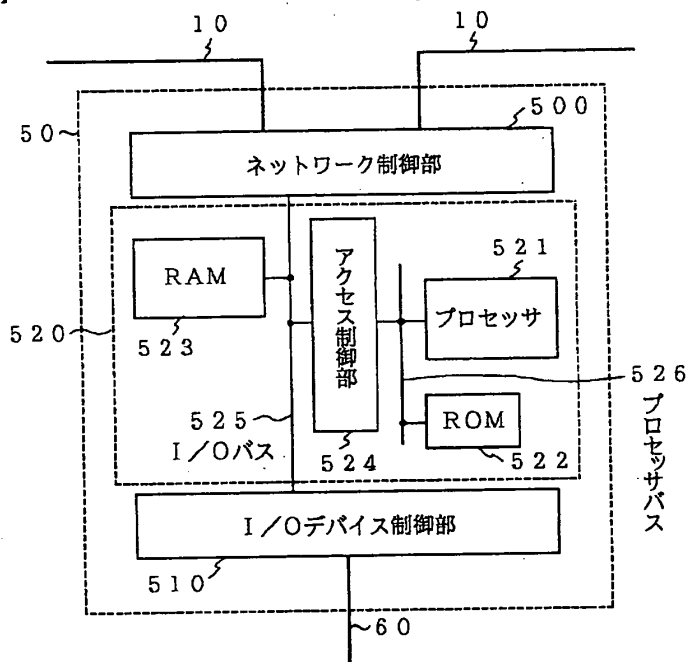

【図3】

[Figure 3]

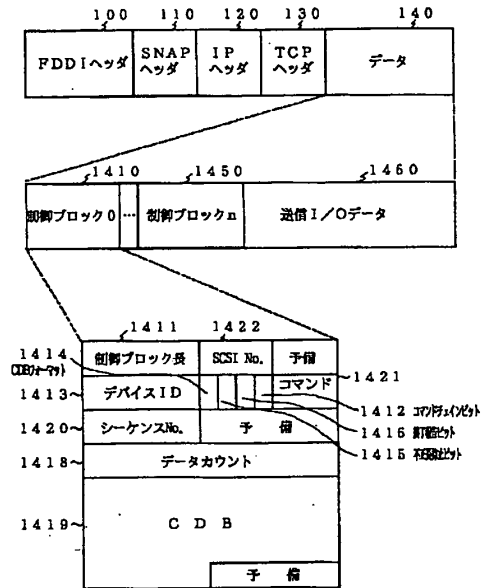

【図4】

[Figure 4]

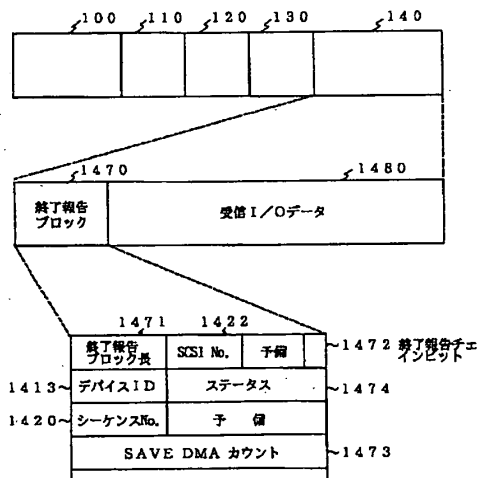

【図5】

[Figure 5]

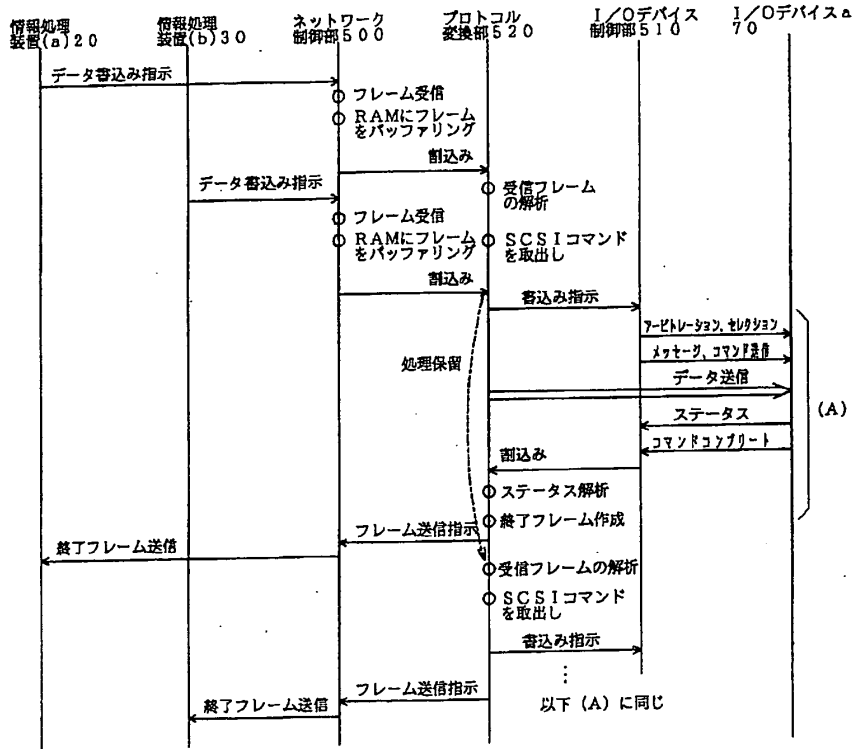

【図6】

[Figure 6]

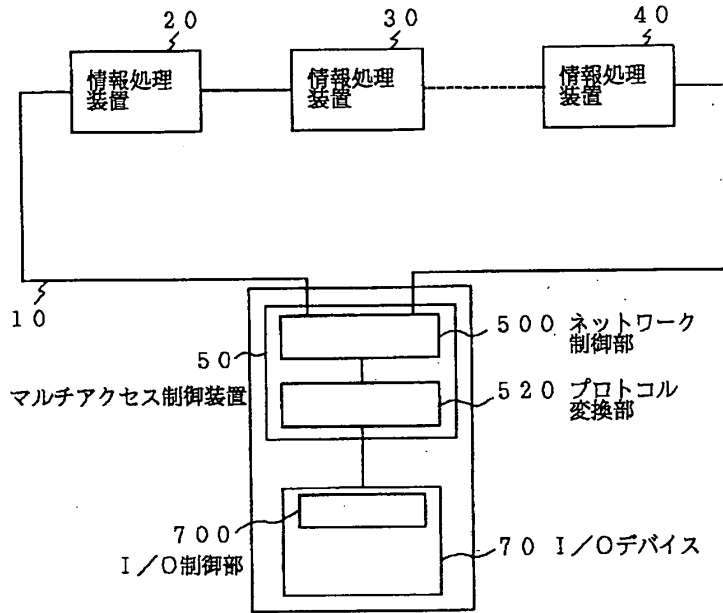

【図8】

[Figure 8]

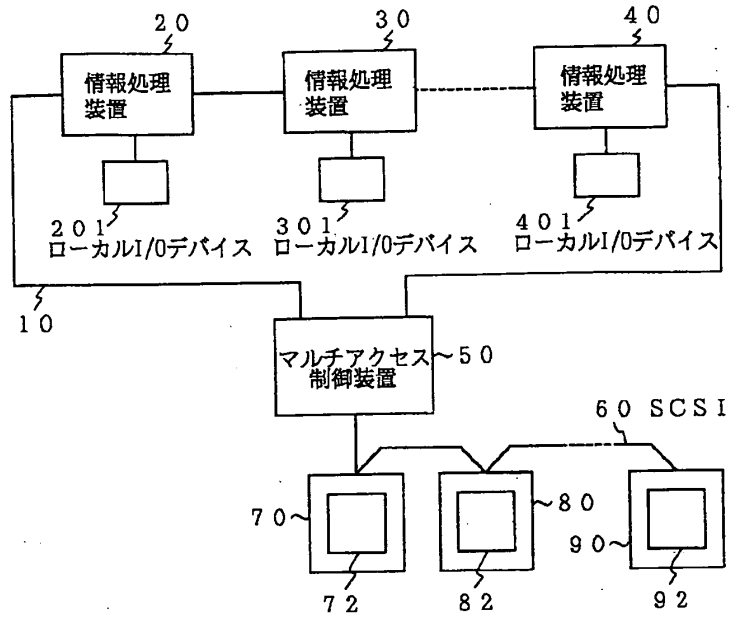

【図7】

[Figure 7]

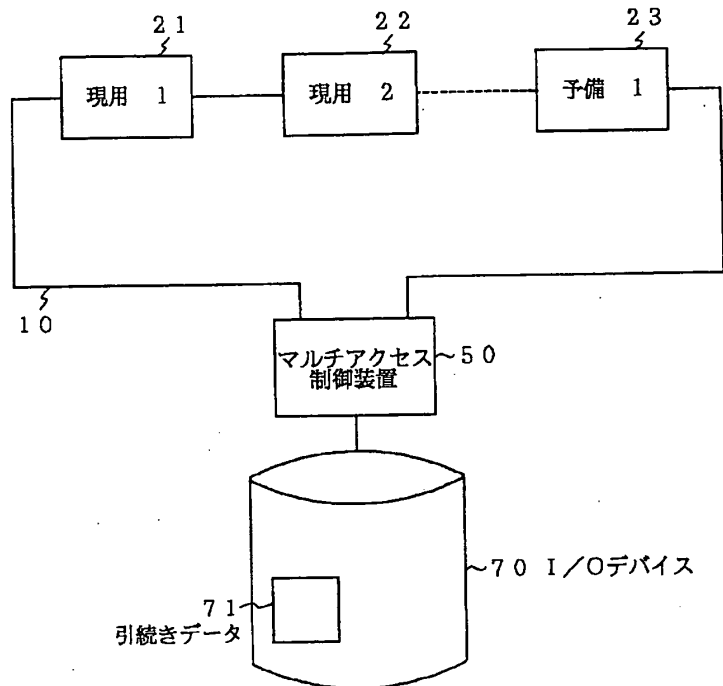



89

INTERNATIONAL APPLICATION PUBLISHED UNDER THE PATENT COOPERATION TREATY (PCT)

<p>(51) International Patent Classification ⁶ : G06F 12/00</p>	<p>A1</p>	<p>(11) International Publication Number: WO 98/36357 (43) International Publication Date: 20 August 1998 (20.08.98)</p>
<p>(21) International Application Number: PCT/US98/02131 (22) International Filing Date: 5 February 1998 (05.02.98) (30) Priority Data: 08/796,085 5 February 1997 (05.02.97) US (71) Applicant: TRANSWITCH CORPORATION [US/US]; 3 Enterprise Drive, Shelton, CT 06484 (US). (72) Inventors: LAU, Joseph, C.; 1F, 29 Bamboo Road III, Science-based Industry Park, Hsinchu (TW). ROY, Subhash, C.; Apartment 3A, 905 Mix Avenue, Hamden, CT 06514 (US). CALLAERTS, Dirk, L., M.; Hoevestraat 13, B-3110 Rotselaar (BE). VANDEWEERD, Ivo, Edmond, Nicole; Vuurkruisenlaan 1, B-3500 Hasselt (BE). (74) Agent: GORDON, David, P.; 65 Woods End Road, Stamford, CT 06905 (US).</p>	<p>(81) Designated States: CA, CN, IL, JP, MX, NO, European patent (AT, BE, CH, DE, DK, ES, FI, FR, GB, GR, IE, IT, LU, MC, NL, PT, SE). Published <i>With international search report. Before the expiration of the time limit for amending the claims and to be republished in the event of the receipt of amendments.</i></p>	

(54) Title: SHARED MEMORY CONTROL USING MULTIPLE LINKED LISTS WITH POINTERS, STATUS FLAGS, MEMORY BLOCK COUNTERS AND PARITY

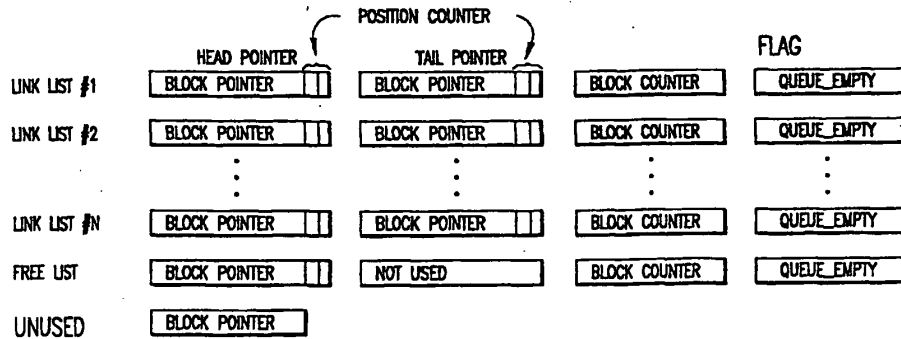

(57) Abstract

Apparatus and methods for allocating shared memory utilizing linked lists (LLs) use a management RAM which controls the flow of data to/from a shared memory (RAM), and stores information regarding a number of LLs and a free link list (FLL) in the RAM, and a block pointer to unused RAM locations. A head pointer (HP), tail pointer (TP), block counter and empty flag (EF) are stored for each data link list. The HP and TP each include a block pointer and a position counter. The block counter contains the number of blocks used in the particular queue. An EF indicates an empty queue. The FLL includes a HP, a block counter, and an EF. Each page of RAM receiving the incoming data includes locations for storing data. The last location of the last page in a block stores a next-block pointer plus parity information, and in the last block of a queue, is set to all ones. An independent agent used in the background monitors the integrity of the LL structure.

FOR THE PURPOSES OF INFORMATION ONLY

Codes used to identify States party to the PCT on the front pages of pamphlets publishing international applications under the PCT.

AL	Albania	ES	Spain	LS	Lesotho	SI	Slovenia
AM	Armenia	FI	Finland	LT	Lithuania	SK	Slovakia
AT	Austria	FR	France	LU	Luxembourg	SN	Senegal
AU	Australia	GA	Gabon	LV	Latvia	SZ	Swaziland
AZ	Azerbaijan	GB	United Kingdom	MC	Monaco	TD	Chad
BA	Bosnia and Herzegovina	GE	Georgia	MD	Republic of Moldova	TG	Togo
BB	Barbados	GH	Ghana	MG	Madagascar	TJ	Tajikistan
BE	Belgium	GN	Guinea	MK	The former Yugoslav Republic of Macedonia	TM	Turkmenistan
BF	Burkina Faso	GR	Greece	ML	Mali	TR	Turkey
BG	Bulgaria	HU	Hungary	MN	Mongolia	TT	Trinidad and Tobago
BJ	Benin	IE	Ireland	MR	Mauritania	UA	Ukraine
BR	Brazil	IL	Israel	MW	Malawi	UG	Uganda
BY	Belarus	IS	Iceland	MX	Mexico	US	United States of America
CA	Canada	IT	Italy	NE	Niger	UZ	Uzbekistan
CF	Central African Republic	JP	Japan	NL	Netherlands	VN	Viet Nam
CG	Congo	KE	Kenya	NO	Norway	YU	Yugoslavia
CH	Switzerland	KG	Kyrgyzstan	NZ	New Zealand	ZW	Zimbabwe
CI	Côte d'Ivoire	KP	Democratic People's Republic of Korea	PL	Poland		
CM	Cameroon	KR	Republic of Korea	PT	Portugal		
CN	China	KZ	Kazakistan	RO	Romania		
CU	Cuba	LC	Saint Lucia	RU	Russian Federation		
CZ	Czech Republic	LI	Liechtenstein	SD	Sudan		
DE	Germany	LK	Sri Lanka	SE	Sweden		
DK	Denmark	LR	Liberia	SG	Singapore		
EE	Estonia						

SHARED MEMORY CONTROL USING MULTIPLE LINKED LISTS WITH POINTERS, STATUS FLAGS, MEMORY BLOCK COUNTERS AND PARITY

This application is related to co-owned U.S. Serial No. 08/650,910, filed May 17, 1996, which is hereby incorporated by reference herein in its entirety.

BACKGROUND OF THE INVENTION

1. Field of the Invention

The present invention relates to memory management. More particularly, the present invention relates to apparatus and methods of managing a plurality of data queues stored in linked lists in a shared common memory. The invention has particular application to the use of a very large scale integrated circuit (VLSI) for the buffering of telecommunications information such as ATM data, although it is not limited thereto.

2. State of the Art

In high speed communication networks, the management of buffer resources is one mechanism of increasing network performance. One group of methods of managing buffer resources is known as sharing, where a single RAM is simultaneously utilized as a buffer by a plurality of different channels. Various sharing methods are known (see Velamuri, R. et al., "A Multi-Queue Flexible Buffer Manager Architecture", IEEE Document No. 0-7803-0917-0/93) and each has inherent advantages coupled with inherent disadvantages in terms of blocking probability, utilization, throughput, and delay. What is common to all sharing methods, however, is that a mechanism is required to direct data into appropriate locations in the RAM in a desired order so that the data can be retrieved from the RAM appropriately. One such mechanism which is well known is the use of link lists which are used to manage multiple queues sharing a common memory buffer. Typically, a link list comprises bytes of data, where each byte has at least one pointer (forward and/or backward) attached to it, thereby identifying the location of the next byte of data in the queue. The link list typically includes extensive

initialization and self-check procedures which are carried out by a microprocessor on a non-real-time basis. Thus, the use of standard prior art link list structures to manage multiplex queues sharing a common memory is not readily adaptable for VLSI implementation, and is likewise not particularly suited to the handling of very high speed telecommunications information where processing and handling are dictated by the data rate of the real-time telecommunications signal.

SUMMARY OF THE INVENTION

It is therefore an object of the present invention to provide an apparatus and method for control of memory allocation.

It is another object of the invention to provide a new link list structure for managing queues in a shared memory.

It is a further object of the invention to provide a single VLSI which utilizes a link list structure for managing queues of high speed real time data in a shared memory.

It is an additional object of the invention to provide a link list apparatus and method for controlling the flow of Asynchronous Transfer Mode (ATM) telecommunications data into and out of a shared buffer.

Another object of the invention is to provide an apparatus and method for VLSI control of ATM data into and out of a shared RAM by utilizing a separate RAM containing information related to the plurality of link lists in the shared RAM.

In accord with the objects of the invention a management RAM contained within a VLSI is provided for controlling the flow of data into and out of a shared memory (data RAM). The management RAM is preferably structured as an x by y bit RAM which stores information regarding y-2 data link lists in the shared RAM, a free link list in the shared RAM, and a block pointer to unused shared RAM locations. Information stored in the x bits for each

data link list includes a head pointer, a tail pointer, a block counter and an empty flag. In a preferred embodiment particularly applicable to the control of ATM data, the head and tail pointers are each composed of a block pointer and a position counter, with the position counter indicating a specific page in a block which is made up of a set of contiguous pages of memory, and the block pointer pointing to the block number. Regardless of how constituted, the head pointer contains the address of the first word of the first memory page of the link list, and the tail pointer preferably contains the address of the first word of the last memory page in the link list. The block counter contains the number of blocks used in the particular queue, and has a non-zero value if at least one page is used in the queue. The empty flag indicates whether the queue is empty such that the content of the link list should be ignored if the queue-empty flag indicates that the queue is empty.

Information stored in the management RAM for the free link list includes a head pointer, a block counter, and an empty flag, but does not need to include a tail pointer as free blocks are added to the top of the free list according to the preferred embodiment of the invention. As is discussed below in more detail, as data from different channels is directed into blocks of the data RAM, a link list is kept for each channel. As data is read out of the data RAM, blocks become available to receive new data. It is these freed blocks which are added to the free list. Block space can be assigned from the free list before or after the unused blocks (discussed below) are used.

To avoid excessive initialization requirements, an unused-block pointer is provided in the management RAM, as discussed above, and provides a pointer to the next unused block in memory. Initially all link lists, including the free list, are empty, and the unused block pointer is set to the number of blocks in the memory. As data is written to a block of shared RAM memory, the unused block pointer is decremented. When the unused block pointer equals zero, all of the cell blocks are included in the link lists (including the free link list).

According to a preferred aspect of the invention, each memory page of the shared data RAM receiving the incoming data (which RAM is managed by the management RAM) is composed of M contiguous memory addresses. Depending on the memory type, each address location can be of size B bits. The most common sizes are eight bits (byte), sixteen bits (word), thirty-two bits, and sixty-four bits. The first M-1 locations in the page are used to store data. The last (M'th) location of the last page in the block preferably is used to store the address of the first location of the next block of the queue plus an odd parity bit; i.e., the M'th location of the last page in the block stores a next block pointer plus parity information. If there are no more blocks in the queue, the M'th location in the last page is set to all ones.

According to another aspect of the invention, an independent agent is utilized in the background to monitor the integrity of the link list structure. The independent agent monitors the sum of the count of all of the link list block counters plus the unused blocks to ensure that it equals the total number of memory blocks in the common RAM. If not, an error is declared. Likewise, the independent agent checks each link list stored in the management RAM for the following error conditions: head and tail pointers are equal and the block counter is not of value one; head and tail pointers are different and the block counter is one; and, block counter equals zero. If desired, the independent agent can also monitor the block pointers stored in the M'th location of the last page of each block to determine parity errors and/or to determine errors using parity or CRC.

Using the methods and apparatus of the invention, four operations are defined for ATM cell management: cell write, cell read, queue clear, and link list monitoring. In the cell write operation, a cell is stored into a queue. More particularly, when an ATM cell is received at a port w so that it is to be stored in queue number n (which stores cells of priority v for port w), a determination is first made as to whether the queue is empty. If it is not empty, the queue status (i.e., the tail

pointer and position counter stored in management RAM) is obtained, and a determination is made as to whether a new block will be needed to be added to the queue. If a new block is not required, the cell is written to the location indicated by the tail pointer position, and the tail pointer position counter for that queue in the management RAM is updated. If this is the last page of a block, the M'th location of the page (in the shared memory) is set to all ones. If a new block is required, either because the queue was empty or because a previous cell had been written into the last page of a block, a block must be obtained. If it is a first block of a queue, initial queue parameters are stored. If it is not the first block of the link list, a block is obtained from the free list and the free list is updated; or the block is obtained from the unused blocks and the block pointer for the unused blocks is updated. Then, the cell is written to the queue, and the tail pointer, position counter, and block counter for the queue are all updated in the management RAM.

The cell read operation is utilized where a cell is to be read from a queue. In the cell read operation, the cell indicated by the head pointer and head pointer position counter for that queue is read from the queue. After reading the cell from the queue a determination is made as to whether the cell was either the last cell in a block and/or the last cell in the queue. If it is neither, then the queue status is updated (i.e., the head pointer position counter is changed), and another cell read operation is awaited. If the cell is the last cell in the block, then the queue status preferably is checked for correctness by verifying the parity of the pointer (using a parity bit), and is updated by changing the head pointer and head pointer position counter. The free list is updated by adding the freed block to the head of the free list, and the free list and link list block counters are updated. If the cell is the last cell in the queue, the procedure for the last cell in the block is followed, and the queue empty flag is set.

The queue clear operation is a microprocessor command provided for the purpose of clearing a queue. When the queue clear operation is presented, the queue status is updated by setting the queue flag, and the blocks in the queue are added to the head of the free list which is likewise updated.

The link list monitoring operation is the agent which monitors the integrity of the link list structure whenever the cell write, cell read, and queue clear operations are not running. As set forth above, the link list monitoring operation monitors the linked lists for errors by checking that the sum of the count of all of the link list block counters plus the unused blocks equals the total number of memory blocks in the common RAM, that when head and tail pointers are equal the block counter is set to one, that when head and tail pointers are different the block counter is not set to one, etc.

Additional objects and advantages of the invention will become apparent to those skilled in the art upon reference to the detailed description taken in conjunction with the provided figures.

BRIEF DESCRIPTION OF THE DRAWINGS

Figure 1 is a block diagram of an apparatus incorporating the link list memory management RAM of the invention.

Figure 2 is a chart showing the structure of the memory management RAM of Figure 1.

Figure 3a is a diagram of an example of the shared data memory of the apparatus of Figure 1.

Figure 3b is a diagram of the details of a page of one of the blocks shown in Figure 3a.

Figure 3c is a diagram of an example of the information contained in the memory management RAM of Fig. 1 for managing the shared data memory example of Figure 3a.

Figures 4a - 4d are flow charts for the write, read, queue clear, and link list monitoring operations carried out by the flow controller of the apparatus of Figure 1.

Figures 5a-5d are state machine diagrams for a write, read, clear, and monitor state machine according to the invention.

DETAILED DESCRIPTION OF THE PREFERRED EMBODIMENTS

The invention will now be described with reference to the physical layer VLSI portion of an ATM destination switch described in parent U.S. Serial No. 08/650,910, although it is not limited thereto. As seen in Fig. 1, and as discussed in the parent application, the physical layer portion 130 of the ATM destination switch 100 preferably includes a UTOPIA interface 150, a managing RAM 162, a flow controller 166, a microprocessor interface 167, channel interface buffers 170, and a RAM interface 175. The flow controller 166 is coupled to the UTOPIA interface 160, the managing RAM 162, the microprocessor interface 167, the channel interface buffers 170, and the RAM interface 175. The UTOPIA interface generally receives cells of ATM data in a byte-wide format, and passes them to the flow controller 166. Based on the destination of the cell (as discussed in the parent application), and the priority of the cell, the flow controller 166 writes the cell into an appropriate output buffer 170. The output buffer is preferably capable of storing at least two ATM cells so that one cell can be read out of the buffer as another is being read into the buffer without conflict. If buffer space is not available for a particular cell at a particular time, the flow controller 166 forwards the ATM cell via the RAM interface 175 to a desired location in a shared RAM 180 (which may be on or off chip) based on information contained in the managing RAM 162 as discussed in more detail below. When room becomes available in the output buffer 170 for the cell, the flow controller 166 reads the data out of the shared RAM 180, and places it in the buffer 170. In the background, when not receiving data from the UTOPIA interface, and when not reading data from or writing data to the shared RAM 180 or writing data to the buffers, the flow

controller 166 monitors the integrity of the link list structure contained in the managing RAM, as is described in more detail below. In addition, the flow controller 166 can perform various functions in response to microprocessor command received via the microprocessor interface 167.

The managing RAM 162 may serve various functions, including providing information for assisting in the processing of the header of the ATM cell as discussed in the parent application hereto. For purposes of this invention, however, the managing RAM 162, or at least a portion thereof, is preferably provided as a x bit by y word RAM for the purpose of managing $y-2$ link lists which are set up in the shared RAM 180 ($y-2$ equalling the product of w ports times v priorities). Thus, as seen in Fig. 2, a link list information structure for $y-2$ data queues includes: a head pointer, a tail pointer, a block counter, and a queue empty flag for each of the $y-2$ data queues; a free list block pointer, block counter, and queue empty flag for a free list; and a block pointer for the unused blocks of memory. Each head pointer and tail pointer preferably includes a block pointer and a position counter, with the block pointer used for pointing to a block in the memory, and the position counter being used to track pages within a block of memory. Thus, for example, where ATM cells of fifty-three bytes of data are to be stored in the shared memory, and each cell is to be stored on a "page", a block having four contiguous pages may be arranged with the position counter being a two bit counter for referencing the page of a block. The block counter for each queue is used to reference the number of blocks contained within the queue. The queue empty flag when set indicates that the queue is empty, and that the pointers contained within the queue as well as the block count can be ignored.

As suggested above, the head pointer for each link list queue contains the address of the first word of the first memory page of the queue in the shared memory. The tail pointer for each link list queue contains the address of the first word of the last memory page in the queue. Each memory page of the shared

memory is composed of M contiguous memory addresses. Depending on the memory type, each address location can be of size B bits, with common sizes being eight bits (byte), sixteen bits (word), thirty-two bits, or sixty-four bits. In accord with the preferred embodiment of the invention, the address locations are sixteen bits in length with the first M-1 locations in a page containing the stored information. The M'th location of a last page in a block is used to store a next block pointer which is set to the first location of the next block plus an odd parity bit. Where the block is the last block in the queue, the M'th location of the last page in the last block is set to all ones. Where the page is neither the last page of the block, nor the last block in the queue, the M'th location of the page is not utilized. In the preferred embodiment of the invention used with respect to ATM telecommunications data, each page is thirty-two words in length (i.e., $M = 32$), with each word being sixteen bits. Thus, an ATM cell of fifty-three bytes can be stored on a single page with room to spare. It should be appreciated, that in some applications, only the data payload portion of the ATM cell (i.e., forty-eight bytes), and not the overhead portion (five bytes) will be stored in the shared memory. In other applications, such as in switches where routing information is added, cells of more than fifty-three bytes may be stored. Regardless, with a thirty-two word page, system addressing is simplified.

An example of the memory organization of the shared memory is seen in Fig. 3a. In Fig. 3a, two active link list data queues are represented, as well as a free list queue and an Unused block. In particular, memory blocks 512, 124, and 122 are shown linked together for a first queue, memory blocks 511, 125, and 123 are linked together for a second queue, memory blocks 510 - 125 are linked together for the free list queue, and memory blocks 121 - 1 are Unused. It will be appreciated that in the preferred embodiment of the invention, each page contains thirty-two sixteen bit words. Thus, the thirty-second (M'th) word of memory block 512 (seen in more detail in Fig. 3b) contains a pointer (the ten least significant bits) which points to memory block 124, the thirty-second word of memory block 124 contains a

pointer which points to memory block 122, and the thirty-second word of memory block 122 contains all ones, thereby indicating the last word in the queue. Likewise, the thirty-second word of memory block 511 contains a pointer which points to memory block 125, the thirty-second word of memory block 125 contains a pointer which points to memory block 123, and the thirty-second word of memory block 123 contains all ones, thereby indicating the last word of that queue.

The free list of Fig. 3a is seen extending from block 510 to block 126. The unused blocks run from block 121 to block 1.

Turning to Fig. 3c, specifics are seen of the management RAM which would be associated with managing the shared memory in the state of Fig. 3a. In particular, information for link list #1 is seen with a head pointer having a block pointer having a value equal to 512 and a position counter set at "00" to indicate a first page of memory in the block storing data. The tail pointer of the link list #1 information has a block pointer having a value equal to 122 and a position counter set to "11" to indicate that all pages of block 122 are being used. The block counter of the information for link list #1 is set to a value of three, and the queue empty flag is not set (i.e., equals zero). Information for link list #2 is seen with a head pointer having a block pointer having a value equal to 511 and a position counter set at "01" to indicate that the data first occurs at a second page of the block (i.e., the first page already having been read from the block). The tail pointer of the link list #2 information has a block pointer having a value equal to 123 and a position counter set at "10" which indicates that there is no data in the last page of the block. The block counter of the link list #2 information is also set to a value of three, and the queue empty flag is not set. The value of the head and tail pointers and block count for the information of link list #N are not indicated, as the queue empty flag of link list #N is set (equals one), thereby indicating that the pointers and block counter do not store valid data. Likewise, while details of information for other link lists are not shown, the only data of interest would

be that the queue empty flags related to all of those link lists would equal one to indicate that no valid data is being stored with reference to those link lists. The head pointer of the free list information has a block pointer set to a value 510, and a block count of 385. The queue empty flag of the free list is not set, as the free list contains data. Finally, the block pointer relating to the Unused queue is shown set to a value of 121. It is noted that in order to increase performance, the free list head pointer and block counter information is preferably implemented in a series of flip-flops, and is thus readily available for purposes discussed below with reference to Figs. 4a-4d. The queue empty flags are also preferably similarly implemented.

It should be appreciated that by providing the queue empty flags and an Unused block pointer, excessive initialization requirements are eliminated. As suggested above, the queue empty flag indicates that there is no valid data for a link list and that the head and tail pointers for that link list and the block counter of that link list can be ignored. The Unused block pointer is provided to point to the next unused block in shared memory. As memory pages are written or used, the Unused block pointer is decremented until a value of zero is reached. At that point, all cell blocks are included in the link lists (including the free list). As previously mentioned, when a block is read from the shared memory, the available block is added to the free list. When a new block is required for adding to a link list, the block space may be taken from either the free list or from the Unused blocks, and available blocks from the free list may be taken either before or after the Unused blocks are used.

Turning now to Figure 4a, a flow chart of operations of the flow controller 166 of the apparatus 100 of Figure 1 is seen with respect to writing data to the shared memory. It is noted that while the operations are shown in flow chart form, in accord with the preferred embodiment of the invention, the operations are carried out in hardware. When the flow controller 166 determines that it is receiving an ATM cell which cannot be written into a

buffer directly, the flow controller makes a determination at 200 (by checking the management RAM queue empty flag associated with that queue) as to whether the queue which should receive that cell is empty. If the queue is not empty, at 202 the queue status (i.e., the tail pointer and position counter) for that queue is obtained, and at 204 a determination is made as to whether a new block will be needed to be added to the queue (i.e., is the position counter equal to "11"). If a new block is not required, at 206 the cell is written to the shared RAM location indicated by the tail pointer position counter for that queue (stored in management RAM), and at 208 the tail pointer position counter for that queue is updated. At 210, a determination is made as to whether the cell is being written into the last page of a block. If so, at 212 the flow controller writes a word of all ones into the M'th location of the page (in the shared memory).

If it is determined that a new block of shared RAM is required to store the incoming cell because at 200 the queue was empty, at 214, a block is obtained from either the free list or from unused RAM. If the block is obtained from the free list, at 216, the free list information is updated by changing the head pointer of the free list (i.e., setting the head pointer to the value stored in the M'th location of the last page of the obtained block), and by decrementing the block counter associated with the free list. If the block is obtained from the unused RAM, the block pointer for the unused RAM is decremented at 216. Regardless, at 218, the cell is written to the queue, and at 220, the tail pointer and block counter for the queue are both updated in the management RAM (with the block counter being set to the value one), and the queue empty flag is changed.

If it is determined that a new block of shared RAM is required to store the incoming cell because at 204 the tail pointer position counter of the link list indicated that the entire tail block is storing data, at 222, a block is obtained from either the free list or from unused RAM. If the block is obtained from the free list, at 224, the free list is updated by

changing the head pointer of the free list (i.e., setting the head pointer to the value stored in the M'th location of the last page of the obtained block), and by decrementing the block counter associated with the free list. If the free list becomes empty because a block is removed, the queue empty flag of the free list is set. If the block is obtained from the unused RAM, the block pointer for the unused RAM is decremented at 224. Regardless, at 228, the cell is written to the queue, and at 230, the tail pointer and block counter for the queue are both updated in the management RAM.

The details of the flow controller operation with respect to a cell read operation (i.e., where a cell is to be read from a queue because a buffer is available to receive the cell) is seen in Fig. 4b. In particular, when a data buffer becomes available, the flow controller at 250 reads the head pointer and tail pointer in the management RAM for the link list associated with the available data buffer. Then, at 252, the flow controller reads from shared memory the cell at the location in the shared memory indicated by the head pointer, and provides the cell to the data buffer. After the data has been read, the flow controller determines at 254 (based on the head pointer and tail pointer) whether the cell was the last cell in the queue, and at 256 (based on the head pointer position counter) whether the cell was the last cell in a block. If it is neither, then at 258 the queue status is updated (i.e., the head pointer position counter is changed), and another cell read operation is awaited. If at 254 it is determined that the cell is the last cell in the queue, at 260, the head pointer for the free list (obtained from the management RAM) is inserted into the last word of the last page of the freed block. Then at 262, the free list in the management RAM is updated by adding the freed block to the head of the free list; i.e., by updating the free list block pointer and block counter. At 264, the queue empty flag is set for the link list which now has no blocks. If the free list was empty prior to adding the freed block, the free list must be initialized (with appropriate head pointer and block counter) and the queue empty flag changed at 264. In addition, in the case were the free list

was empty prior to adding the freed block, the last word in the freed block in the shared RAM should be set to all ones.

If at 256 it is determined that the cell which has been read out of shared memory is the last in a block, then at 266, the head pointer for the free list as obtained from the management RAM is inserted into the last word of the last page of the freed block. Then, at 268, the queue status for the link list is updated by changing the block pointer and position counter of the head pointer (to the value contained in the last word of the page of memory being read out of the shared memory), and by decrementing the block counter. Again, it is noted that if the free list was empty prior to adding the freed block, the free list must be initialized (with appropriate head pointer and block counter) and the queue empty flag changed, and the last word in the freed block in the shared RAM should be set to all ones. It is also noted, that upon obtaining the pointer in the M'th location of the last page of the block, according to the preferred embodiment of the invention, at 270, a parity check is done on the pointer. At 272, the calculated parity value is compared to the parity bit stored along with the pointer. Based on the comparison, at 274, a parity error condition can be declared, and sent as an interrupt message via the microprocessor interface port 167 (Fig. 1) to the microprocessor (not shown). Preferably, when a parity error is found, the microprocessor treats the situation as a catastrophic error and reinitializes the management and data RAMs.

Figure 4c sets out the operation with respect to the queue clear microprocessor command (received via the microprocessor interface 167). When the queue clear operation is presented, at 270 the queue status for the link list is updated by setting the queue empty flag, and at 272, the blocks in the queue are added to the head of the free list which is updated in a manner discussed above (Fig. 4b) with reference to the cell read operation.

The link list monitoring operation seen in Fig. 4d is the hardware agent which monitors the integrity of the link list structure whenever the cell write, cell read, and queue clear operations are not running. The link list monitoring operation preferably monitors four different error conditions. In particular, at 280, the counts of all of the link list block counters (including the free list) where the queue empty flag for those link lists are not set are summed together with the unused blocks and compared the total number of memory blocks in the common RAM. If the sum does not equal the total number of memory blocks in the common RAM, at 281, an error condition is declared by triggering a microprocessor interrupt bit. At 282, the head and tail block pointers of each link list are compared. If at 284 the head and tail block pointers are determined to be equal, at 286 the block counter is checked, and if not equal to one, at 287 an error condition is declared. If the head and tail block pointers are not equal when compared at 284, at 288 the block counter is checked, and if the block count is equal to one, at 289 an error condition is declared. At 290, the block counter for each link list whose queue empty flag is not set is checked; and if the block counter equals zero, at 291 an error condition is declared.

According to the preferred embodiment of the invention, the write, read, clear, and monitoring operations of the flow controller are carried out in hardware which may be generated by using HDL code to synthesize hardware gates via use a VHDL compiler. Figures 5a-5d are state machines diagrams corresponding to the HDL code, including a write state machine (Fig. 5a), a read state machine (Fig. 5b), a clear state machine (Fig. 5c), and a monitoring state machine (Fig. 5d). The gates created using the code may be standard cell technology or gate array technology.

It should be appreciated that the invention is not intended to be limited to a strictly hardware implementation, but is also intended to apply to memory management utilizing a microprocessor with associated firmware (e.g., a ROM).

There have been described and illustrated herein an apparatus and method for management of shared memory. While particular embodiments of the invention have been described, it is not intended that the invention be limited thereto, as it is intended that the invention be as broad in scope as the art will allow and that the specification be read likewise. Thus, while the invention has been described with reference to VLSI implemented ATM equipment, it will be appreciated that the invention has broader applicability. Also, while specific details of RAM sizes, etc. have been disclosed, it will be appreciated that the details could be varied without deviating from the scope of the invention. For example, while a management of RAM of size x bits by y words has been described for managing $y-2$ link lists of data, it will be appreciated that the management RAM could assume different sizes. Thus, for example, instead of using a separate word for the unused block pointer, the unused block pointer could be located in the "tail pointer" location of the free list (which itself does not use a tail pointer), thereby providing a management RAM of x bits by y words for managing $y-1$ link lists of data. In addition, rather than providing the information related to the link lists with the head pointer, tail pointer, block counter, and queue empty flag in that order, the variables of the link list could be reordered. Similarly, instead of providing a shared memory having pages of thirty-two words in depth, each word being sixteen bits in length, it will be appreciated that memories of different lengths and depths could be utilized. Also, rather than locating the pointer to the next block in the last word of the last page of a previous block, it will be appreciated that the pointer could be located in a different location. Further yet, while specific flow charts have been disclosed with respect to various operations, it will be appreciated that various aspects of the operations can be conducted in different orders. In addition, while particular code has been disclosed for generating gate arrays which conduct the operations in hardware, it should be appreciated by those skilled in the art that other code can be utilized to generate hardware, and that hardware and/or firmware can be generated in

different manners. Furthermore, while the invention was described with respect to separate RAMs for the management RAM and the shared data RAM, it will be appreciated that both memories may be part of a larger single memory means. It will therefore be appreciated by those skilled in the art that yet other modifications could be made to the provided invention without deviating from its spirit and scope as so claimed.

Claims:

1. Apparatus for managing the storage of data in a memory, comprising:
 - a) a shared memory means having a plurality of data storage locations;
 - b) control means for receiving said data and forwarding said data to desired of said plurality of data storage locations in said shared memory means, wherein said data is stored in said plurality of data storage locations in the form of a plurality of link lists, each link list having a head;
 - c) management memory means for storing information regarding each of said plurality of link lists, said information including a head pointer and a queue empty flag for each link list, said head pointer for each particular respective link list pointing to a location of a respective said head of that particular link list, and said queue empty flag for a link list indicating that that link list has no valid data contained therein.
2. An apparatus according to claim 1, wherein:
 - said control means reads data from said shared memory means, at least a plurality of said data storage locations are in the form of a free link list, said free link list relating to data storage locations from which data has been read by said control means, and
 - said management memory means includes a pointer and a queue empty flag for said free link list.
3. An apparatus for managing the storage of data in a memory, comprising:
 - a) a shared memory means having a plurality of data storage locations;
 - b) control means for receiving said data and forwarding said data to desired of said plurality of data storage locations in said shared memory means, and for reading data from said shared memory means, wherein said data is stored in said plurality of data storage locations in the form of a plurality of link lists, each link list having a head;

c) management memory means for storing information regarding each of said plurality of link lists, said information including a head pointer for each link list queue, said head pointer for each particular respective link list pointing to a location of a respective said head of that particular link list,

wherein upon initialization, at least a plurality of said data storage locations of said shared memory means are unused, and after utilization, at least a plurality of said data storage locations are in the form of a free link list, said free link list relating to data storage locations from which data has been read by said control means, and

wherein said management memory means includes a pointer to at least one of said unused data storage locations, and said management memory means includes a pointer for said free link list.

4. An apparatus according to any preceding claim, wherein:

at least upon initialization, at least a plurality of said data storage locations of said shared memory means are unused, and

said management memory means includes a pointer to at least one of said unused data storage locations.

5. An apparatus according to any previous claim, wherein:

said shared memory means is arranged in a plurality of blocks with each block having a plurality of said data storage locations, and

said information stored in said management memory means regarding each of said plurality of link list queues includes a block counter for each of said plurality of link list queues, each block counter counting the number of blocks contained in that link list queue.

6. An apparatus according to claim 5, wherein:

each of said plurality of blocks is arranged as a plurality of contiguous pages with each page having a plurality of said data storage locations, and

each said head pointer comprises a block pointer which points to a block and a page counter which points to a page in said block.

7. An apparatus according to claim 5, wherein:

each block storing data includes at least one location containing one of (i) a pointer to a next block in the link list, and (ii) an indicator which indicates that the block is the last block in the link list.

8. An apparatus according to claim 7, wherein:

said pointer to a next block in the link list includes a parity bit for said pointer.

9. An apparatus according to claim 6, wherein:

each block storing data includes at least one location in a last page of that block containing one of (i) a pointer to a next block in the link list, and (ii) an indicator which indicates that the block is the last block in the link list.

10. An apparatus according to any previous claim, wherein:

said information includes a tail pointer for each link list containing said data.

11. An apparatus according to claim 6, wherein:

said information includes a tail pointer for each link list containing said data,

each of said plurality of blocks is arranged as a plurality of contiguous pages with each page having a plurality of said data storage locations,

each said head pointer comprises a first block pointer which points to a block and a page counter which points to a page in said block, and

each said tail pointer comprises a second block pointer which points to a tail block and a page counter which points to a page in said tail block.

12. An apparatus according to claim 6, wherein:
said data comprises ATM data received in cell format, and each said page includes enough of said data storage locations to store all of the data contained in an ATM cell.
13. An apparatus according to claim 12, wherein:
each page includes thirty-two sixteen bit word locations.
14. An apparatus according to claim 5, wherein:
said control means reads data from said shared memory means, at least a plurality of said data storage locations are in the form of a free link list, said free link list relating to data storage locations from which data has been read by said control means, and
said management memory means includes a pointer, a block counter, and a queue empty flag for said free link list, at least a plurality of said data storage locations of said shared memory means are unused, and
said management memory means includes a pointer to said at least one of said unused data storage locations, and
said control means includes means for comparing a sum of counts of said block counters of each link list containing data, said free link list, and said unused pointer to the number of blocks in said shared memory means.
15. An apparatus according to claim 14, wherein:
said control means further comprises means for generating an error signal is said sum of counts does not equal said number of blocks in said shared memory means.
16. An apparatus according to claim 10, wherein:
said control means includes means for comparing, for each link list containing data, said tail pointer to said head pointer.

17. An apparatus according to claim 16, wherein:

said control means further comprises means for generating an error signal if said tail pointer and said head pointer for a link list containing data point to an identical block, and said block counter for said link list does not equal one.

18. An apparatus according to claim 16, wherein:

said control means further comprises means for generating an error signal if said tail pointer and said head pointer for a link list containing data point to different blocks, and said block counter for said link list equals one.

19. An apparatus according to claim 5, wherein:

said control means further comprises means for checking the count of each block counter of a link list where the queue empty flag is not set, and for generating an error signal if the count is zero and the queue empty flag is not set.

20. An apparatus according to any preceding claim, wherein:

said control means and said management memory means are contained on a single integrated circuit.

21. An apparatus according to claim 5, wherein:

said management memory means includes said pointer, a block counter, and a queue empty flag for said free link list, and said control means includes means for comparing a sum of counts of said block counters of each link list containing data, said free link list, and said unused pointer to the number of blocks in said shared memory means, and means for generating an error signal if said sum of counts does not equal said number of blocks in said shared memory means.

22. An apparatus according to claim 10, wherein:

said control means includes means for comparing, for each link list containing data, said tail pointer to said head pointer, and means for generating an error signal if either

(i) said tail pointer and said head pointer for a link list containing data point to an identical block, and said block counter for said link list does not equal one, or

(ii) said tail pointer and said head pointer for a link list containing data point to different blocks, and said block counter for said link list equals one.

23. A method of managing the storage of data utilizing a controller, a shared memory having a plurality of data storage locations, and a management memory, said method comprising:

a) using said controller to forward received data to desired of the plurality of data storage locations in the shared memory, wherein the data is stored in the plurality of data storage locations in the form of a plurality of link lists, each link list having a head; and

b) storing information regarding each of the plurality of link lists in the management memory, said information including a head pointer and a queue empty flag for each link list, said head pointer for each particular respective link list pointing to a location of a respective said head of that particular link list, and said queue empty flag for a link list indicating that that link list has no valid data contained therein.

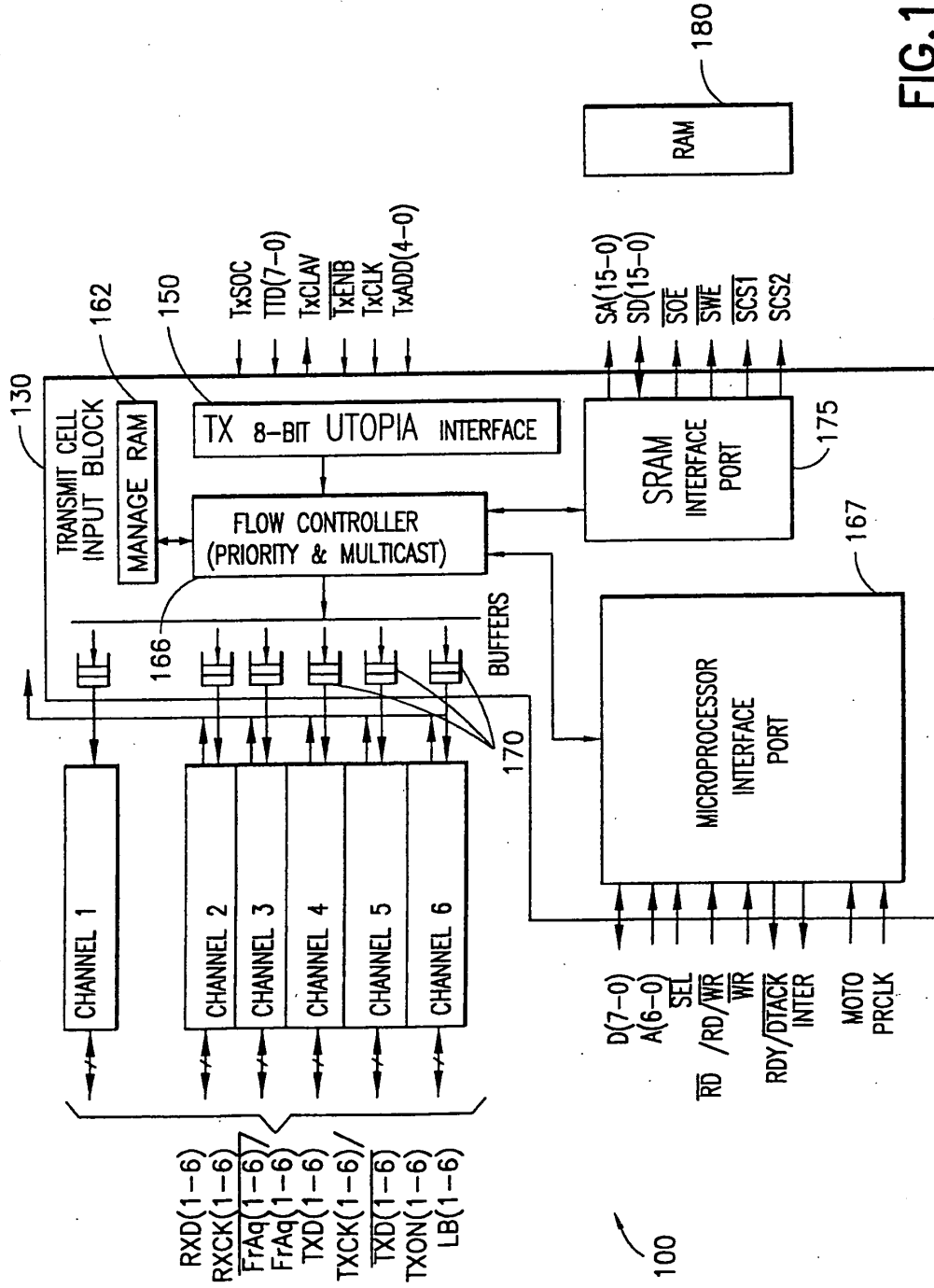

FIG.1

SUBSTITUTE SHEET (RULE 26)

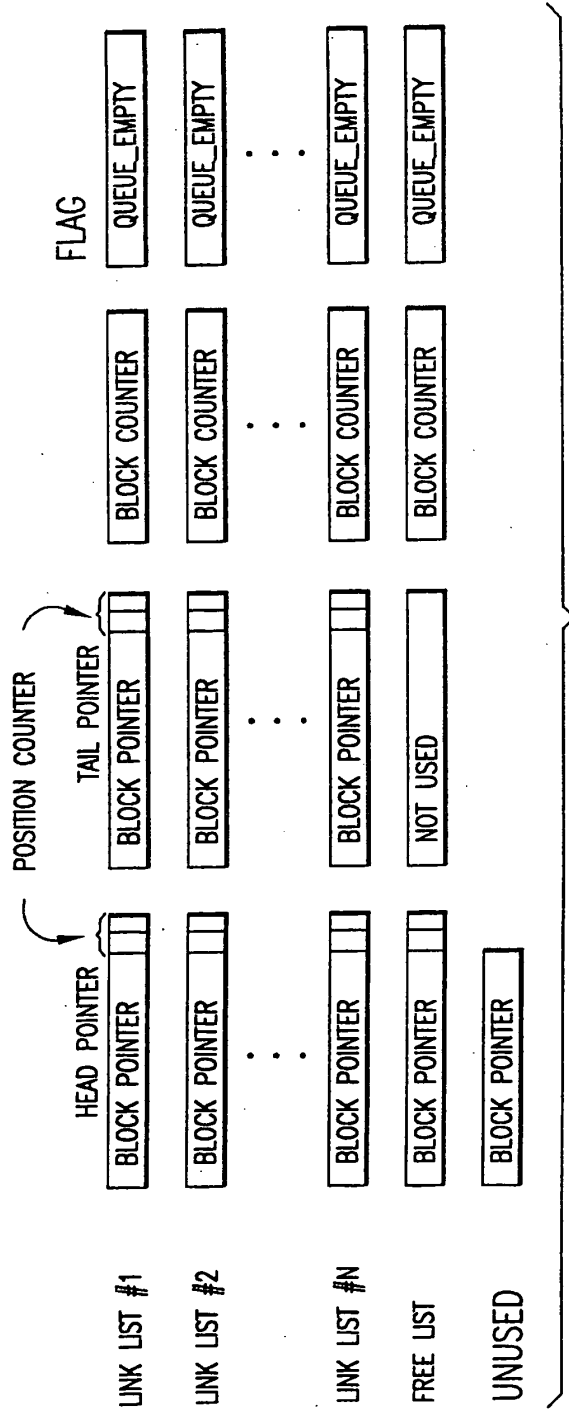

FIG.2

SUBSTITUTE SHEET (RULE 26)

3/11

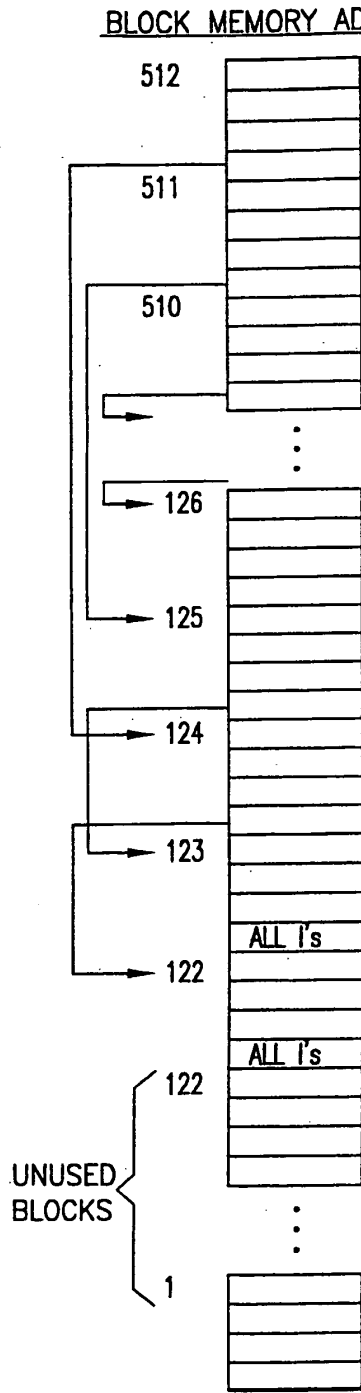

FIG.3a

CONSTITUTE SHEET (RULE 26)

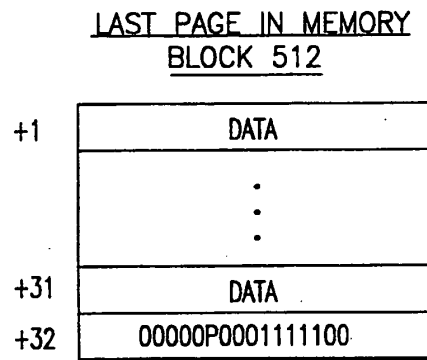

FIG.3b

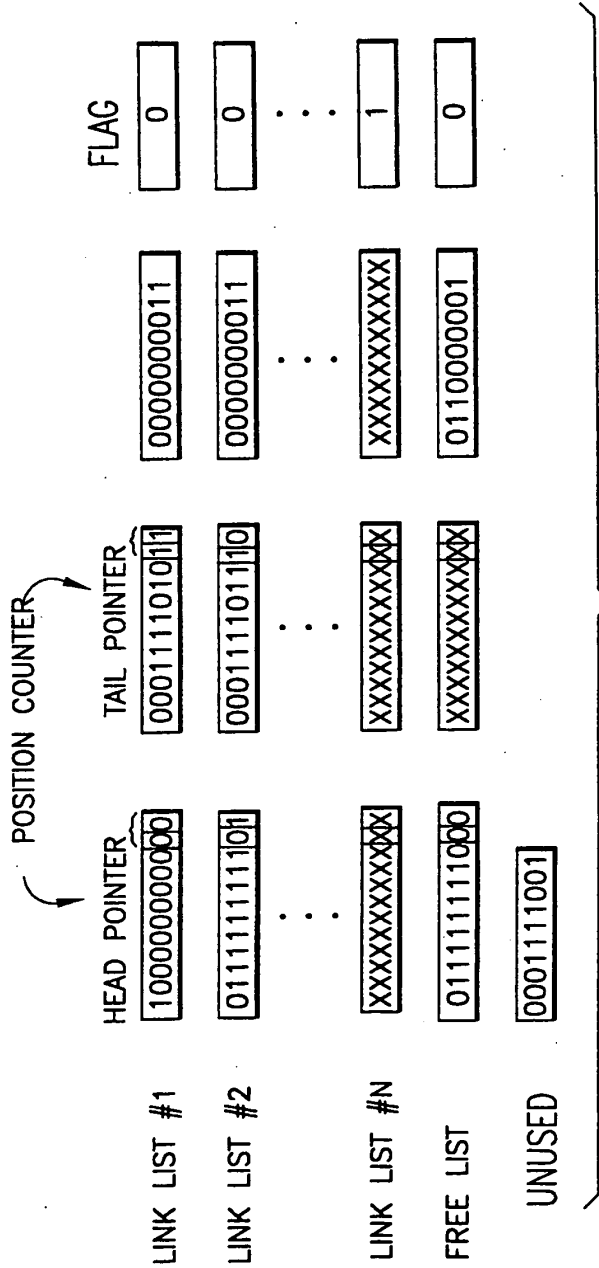

FIG.3c

5/11

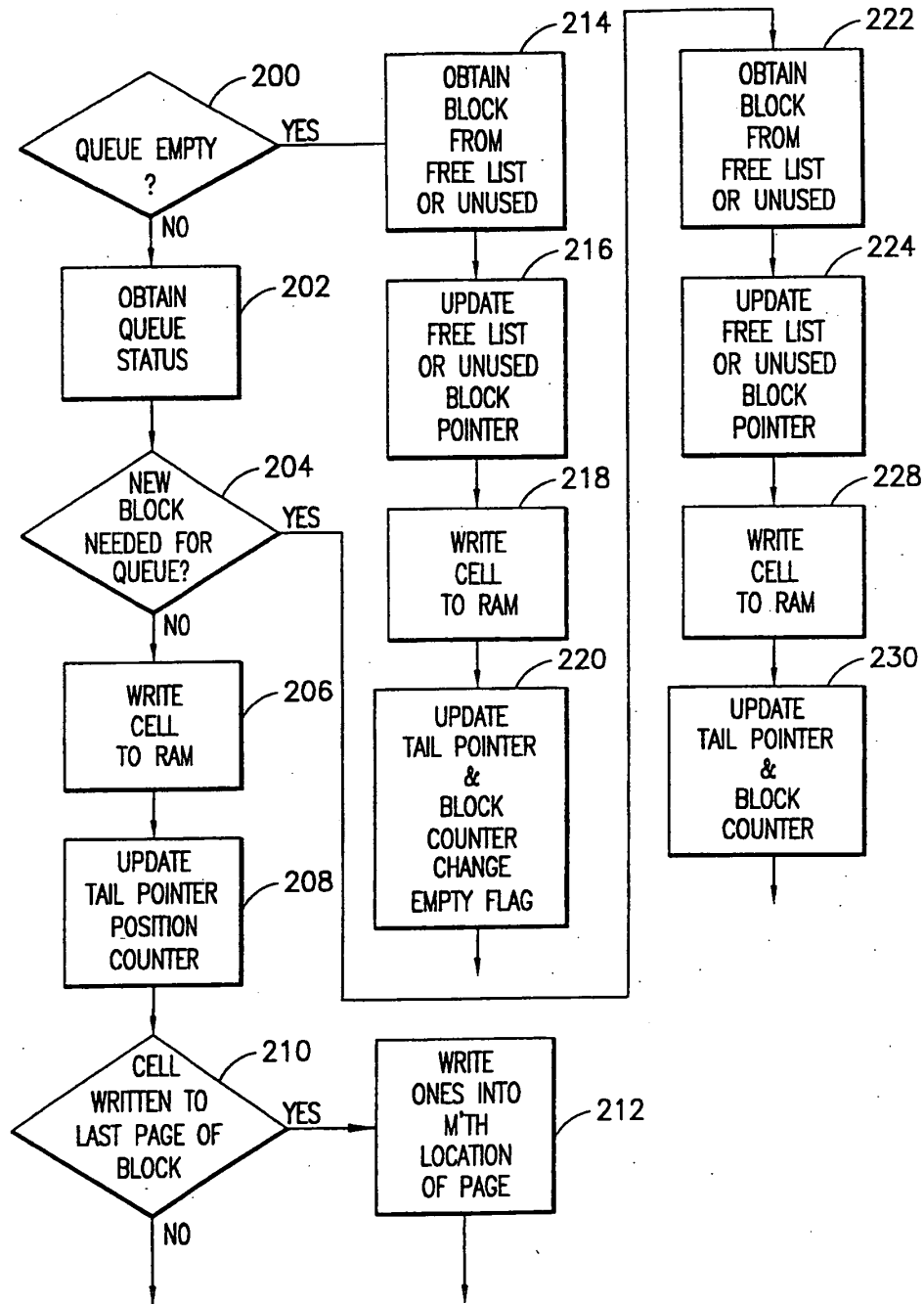

FIG.4a

SUBSTITUTE SHEET (RULE 26)

6/11

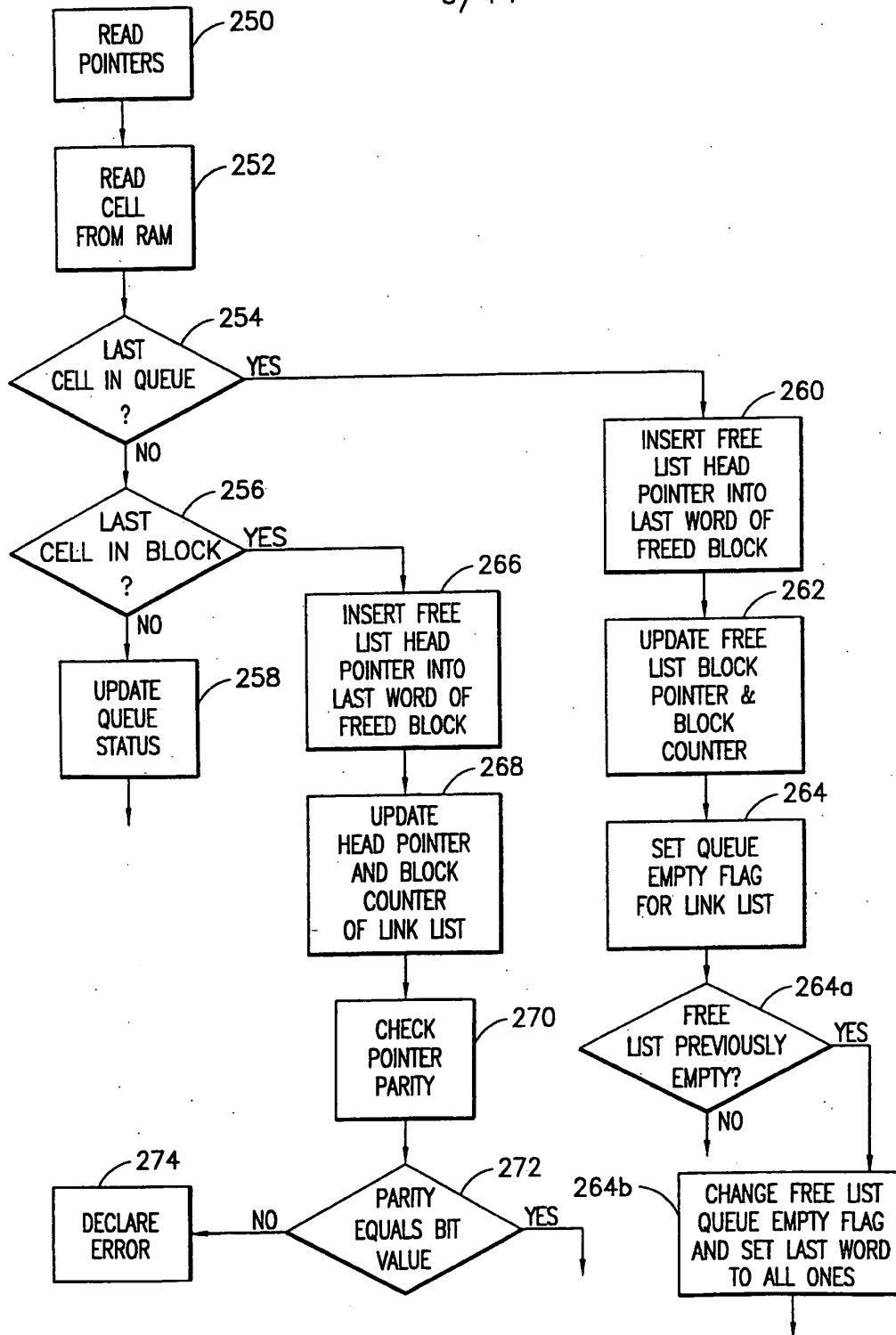
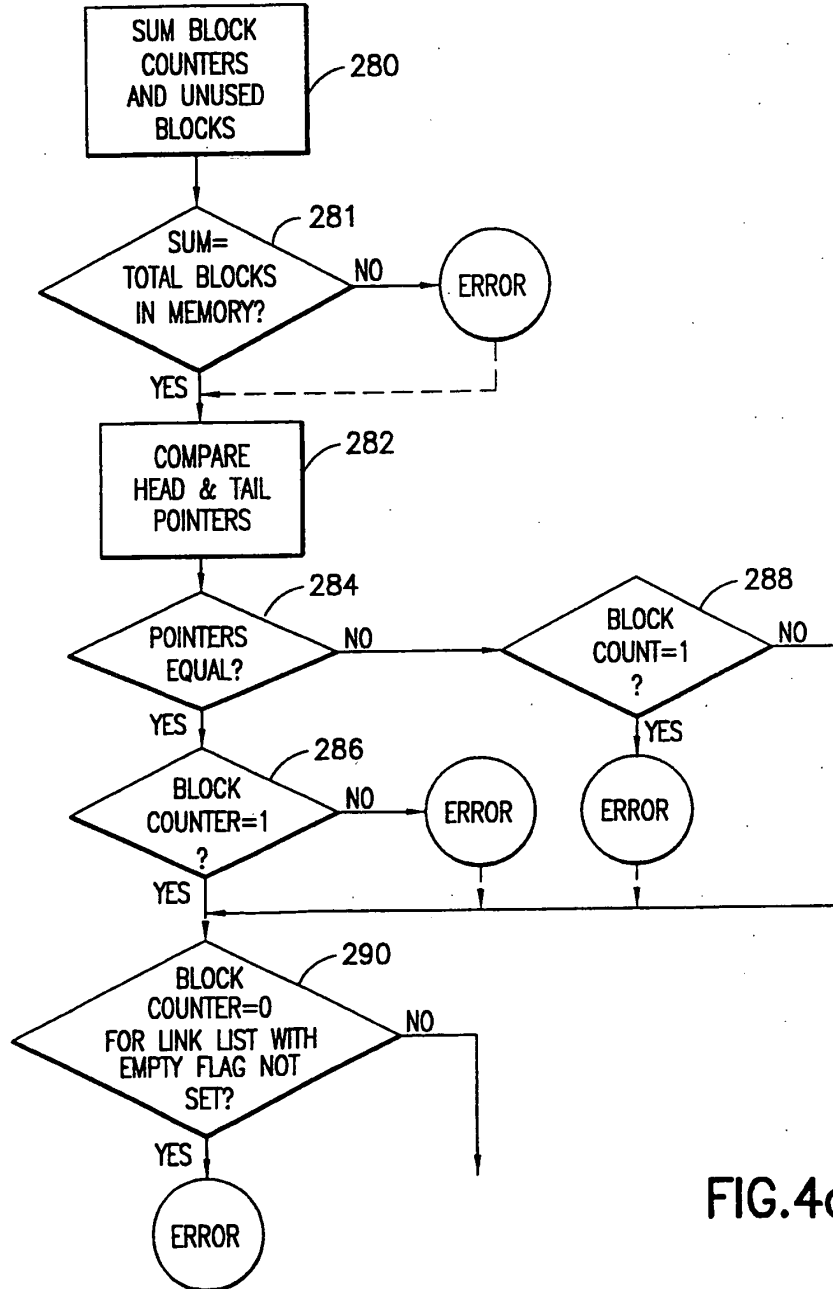
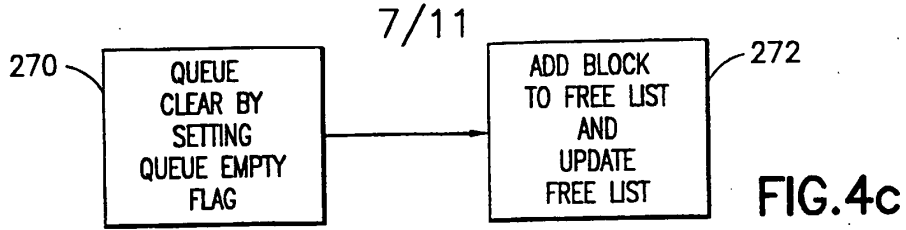

FIG. 4b

SUBSTITUTE SHEET (RULE 26)



SUBSTITUTE SHEET (RULE 26)

8/11

WRITE STATE MACHINE

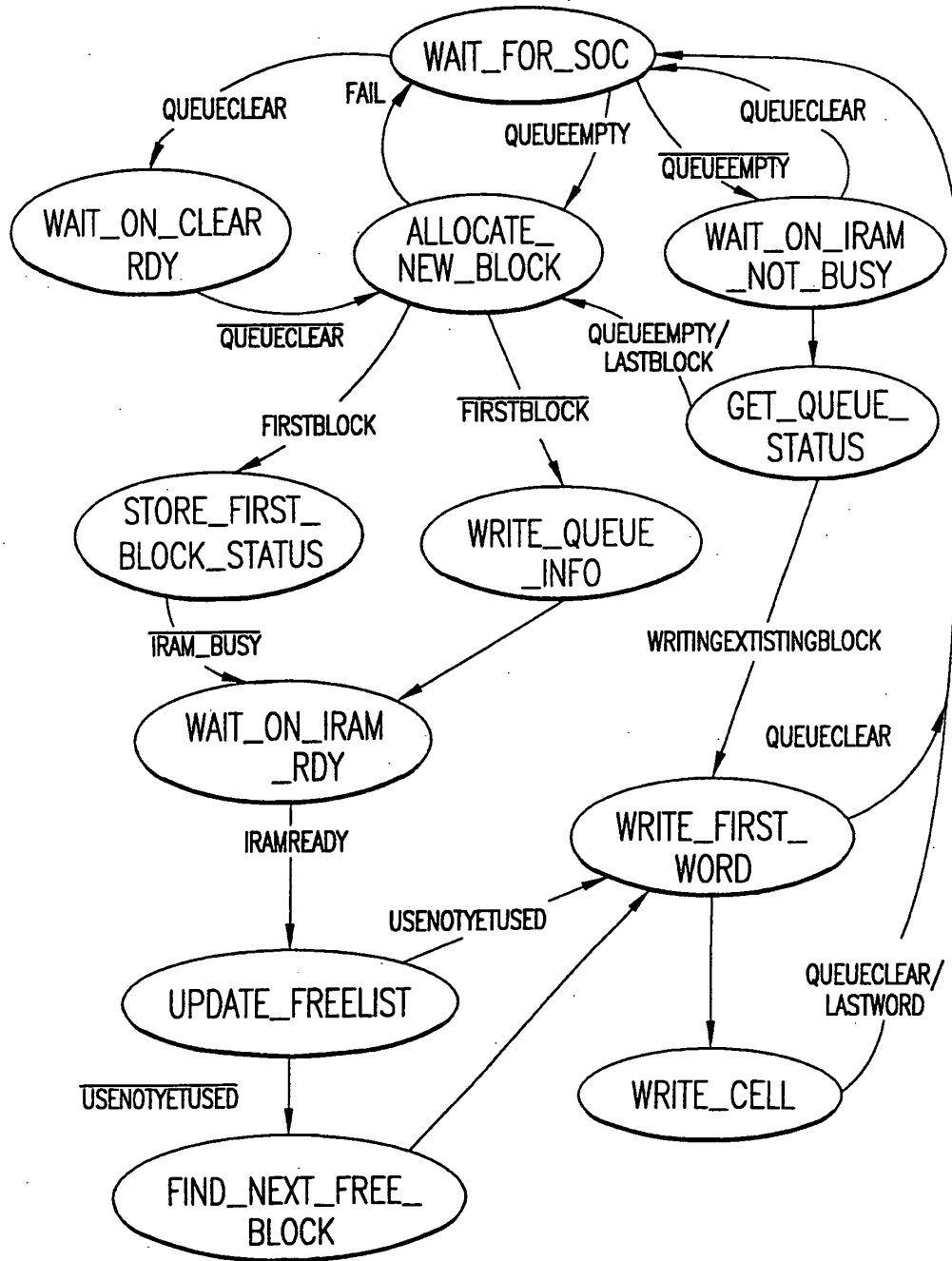

FIG.5a

SUBSTITUTE SHEET (RULE 26)

9/11

READ STATE MACHINE

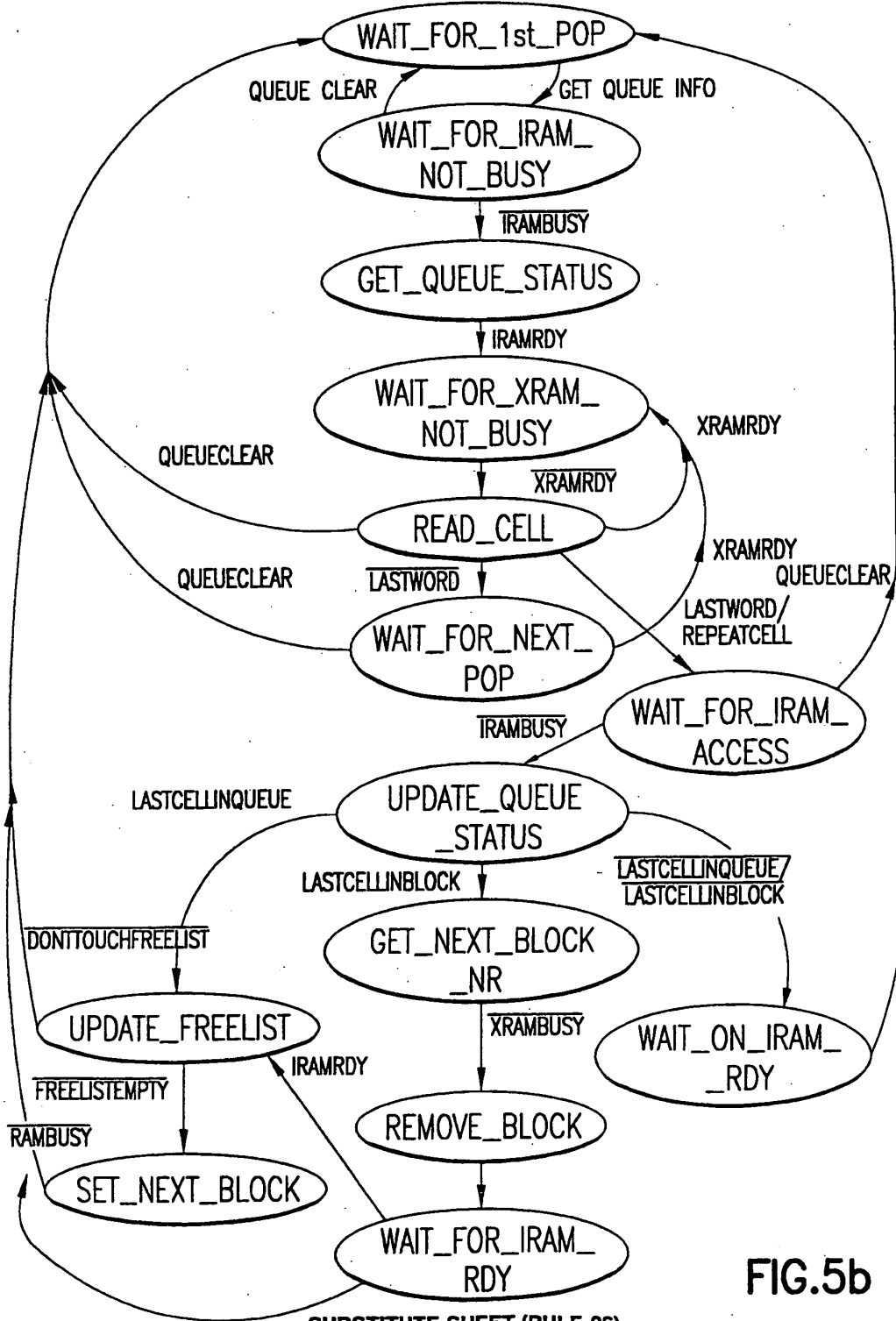

FIG.5b

SUBSTITUTE SHEET (RULE 26)

10/11

CLEAR STATE MACHINE

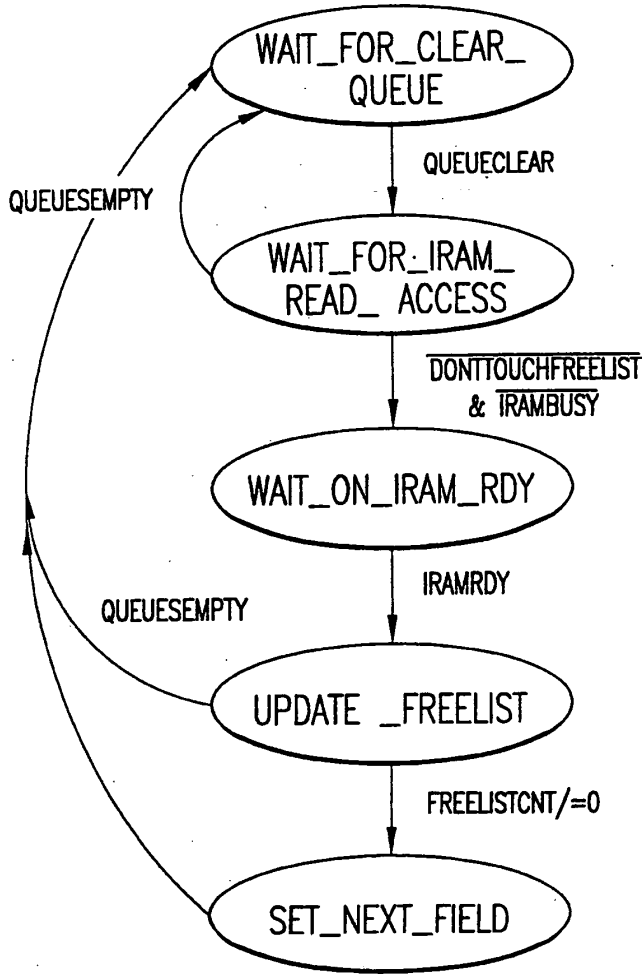

FIG.5c

SUBSTITUTE SHEET (RULE 26)

MONITORING STATE MACHINE

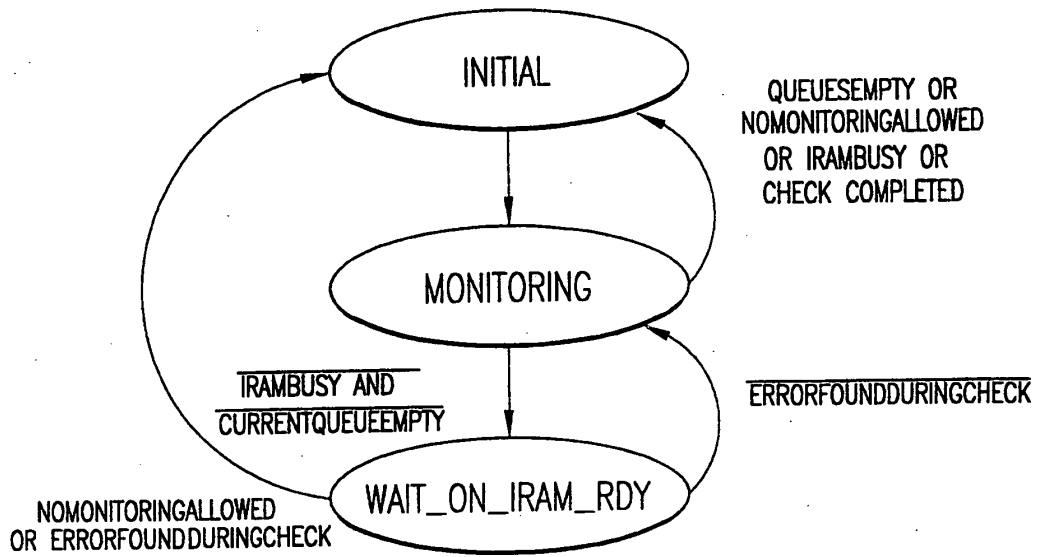

FIG.5d

INTERNATIONAL SEARCH REPORT

International application No.
PCT/US98/02131

A. CLASSIFICATION OF SUBJECT MATTER IPC(6) :G06F 12/00 US CL :711/153 According to International Patent Classification (IPC) or to both national classification and IPC		
B. FIELDS SEARCHED Minimum documentation searched (classification system followed by classification symbols) U.S. : 711/153, 711/207, 370/232, 370/398 Documentation searched other than minimum documentation to the extent that such documents are included in the fields searched Electronic data base consulted during the international search (name of data base and, where practicable, search terms used) APS, MAYA		
C. DOCUMENTS CONSIDERED TO BE RELEVANT		
Category*	Citation of document, with indication, where appropriate, of the relevant passages	Relevant to claim No.
X — Y	US 5,390,175 A (HILLER ET AL.) 14 February 1995, col. 45, line 10; Fig. 24; col. 37, line 20; col. 37, line 25; col. 21, line 35; col. 22, line 37; col. 20, line 63; col. 54, line 34; col. 55, line 53; col. 35, line 56; col. 21, line 60; col. 37, line 19; col. 35, line 56	1-5, 7, 8, 10, 14-19, 20, 21, 22, 23 6, 9, 11-13
Y	US 5,123,101 A (SINDHU) 16 June 1992, col. 21, line 68.	6, 9, 11-13
A, P	US 5,654,962 A (ROSTOKER ET AL) 05 August 1997	1-23
<input type="checkbox"/> Further documents are listed in the continuation of Box C. <input type="checkbox"/> See patent family annex.		
* Special categories of cited documents: *A* document defining the general state of the art which is not considered to be of particular relevance *E* earlier document published on or after the international filing date *L* document which may throw doubts on priority claim(s) or which is cited to establish the publication date of another citation or other special reason (as specified) *O* document referring to an oral disclosure, use, exhibition or other means *P* document published prior to the international filing date but later than the priority date claimed *T* later document published after the international filing date or priority date and not in conflict with the application but cited to understand the principle or theory underlying the invention *X* document of particular relevance; the claimed invention cannot be considered novel or cannot be considered to involve an inventive step when the document is taken alone *Y* document of particular relevance; the claimed invention cannot be considered to involve an inventive step when the document is combined with one or more other such documents, such combination being obvious to a person skilled in the art *A* document member of the same patent family		
Date of the actual completion of the international search 30 MARCH 1998		Date of mailing of the international search report 04 AUG 1998
Name and mailing address of the ISA/US Commissioner of Patents and Trademarks Box PCT Washington, D.C. 20231 Facsimile No. (703) 305-3230		Authorized officer DAVID LANGJAHR <i>Jon Holt</i> Telephone No. (703) 305-4034

Form PCT/ISA/210 (second sheet) (July 1992)*

1fn

IN THE UNITED STATES PATENT AND TRADEMARK OFFICE	
INFORMATION DISCLOSURE STATEMENT BY APPLICANT	Atty. Docket No. (Opt.) CROSS1120-33



Applicant Geoffrey B. Hoese, et al.	
Application Number 12/690,592	Filed 01/20/2010
For Storage Router and Method for Providing Virtual Local Storage	
Group Art Unit 2111	Examiner Unknown
Confirmation Number: 8115	

Commissioner for Patents
P.O. Box 1450
Alexandria, VA 22313-1450

<u>Certification of Transmission Under 37 C.F.R. 1.8</u>
<p>I hereby certify that this correspondence is being deposited with the U.S. Postal Service as First Class Mail in a box addressed to The Commissioner for Patents, P.O. Box 1450, Alexandria, VA 22312-1450 on <u>5-24</u> 2010</p> <p style="text-align: center;"> _____ Signature</p> <p style="text-align: center;"><u>PAUL H. GOOD</u> _____ Printed Name</p>

Dear Sir,

Applicant respectfully requests, pursuant to 37 C.F.R. §§ 1.56, 1.97 and 1.98, that the information listed on the attached SB08A/B form(s) be considered and cited in the examination of the above-identified application. A copy of U.S. Patent(s) and U.S. Patent Application Publication(s) listed on the attached SB08A form is not being submitted with this Information Disclosure Statement pursuant to the waiver of 37 C.F.R. § 1.98(a)(2)(i) by the U.S. Patent and Trademark Office. A copy of foreign patent documents as well as the information listed on the attached SB08B form is enclosed for the convenience of the Examiner.

- This Information Disclosure Statement is being submitted within three months of the filing date of a national application other than a continued prosecution application under 37 C.F.R. § 1.53(d).
- This Information Disclosure Statement is being submitted within three months of the date of entry of the national stage as set forth in 37 C.F.R. § 1.491 in an international application;
- This Information Disclosure Statement is being submitted before the mailing of a first Office action on the merits; or

This Information Disclosure Statement is being submitted before the mailing of a first Office action after the filing of a request for continued examination under 37 C.F.R. § 1.114.

This Information Disclosure Statement is being submitted after the period specified in 37 C.F.R. § 1.97(b) and before the mailing date of any of a final action under 37 C.F.R. § 1.113, a notice of allowance under 37 C.F.R. § 1.311, or an action that otherwise closes prosecution in the application, and is accompanied by one of:

- The statement specified in 37 C.F.R. § 1.97(e); or
- The fee set forth in 37 C.F.R. § 1.17(p). Applicant hereby authorizes the Commissioner to deduct the amount of \$180 from Deposit Account No. 50-3183 of Sprinkle IP Law Group for the filing fee of this Information Disclosure Statement.

This Information Disclosure Statement is being submitted after the period specified in 37 C.F.R. § 1.97(c) and on or before payment of the issue fee and is accompanied by:

- The statement specified in 37 C.F.R. § 1.97(e); and
- The fee set forth in 37 C.F.R. § 1.17(p). Applicant hereby authorizes the Commissioner to deduct the amount of \$180 from Deposit Account No. 50-3183 of Sprinkle IP Law Group for the filing fee of this Information Disclosure Statement.

Pursuant to 37 C.F.R. § 1.97(e), Applicant hereby states:

That each item of information contained in the information disclosure statement was first cited in any communication from a foreign patent office in a counterpart foreign application not more than three months prior to the filing of the information disclosure statement; or

That no item of information contained in the information disclosure statement was cited in a communication from a foreign patent office in a counterpart foreign application, and, to the knowledge of the person signing the certification after making reasonable inquiry, no item of information contained in the information disclosure statement was known to any individual designated in 37 C.F.R. § 1.56(c) more than three months prior to the filing of the information disclosure statement.

Furthermore, pursuant to 37 C.F.R. §§ 1.97(g) and (h), no representation is made that a search has been made or that this information is material to patentability of the present application.

Applicant respectfully submits that the claims of Applicant's above-referenced patent application are patentably distinguishable from the listed information.

Respectfully submitted,

Sprinkle IP Law Group
Attorneys for Applicant

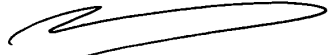
John L. Adair
Reg. No. 48,828

Dated: 5-13-2010

1301 W. 25th Street, Suite 408
Austin, Texas 78705
Tel. (512) 637-9220
Fax. (512) 317-9088



*CBK
R15*

(12) **EUROPEAN PATENT SPECIFICATION**

- (45) Date of publication and mention of the grant of the patent: **25.02.1998 Bulletin 1998/09**
- (21) Application number: **90913922.2**
- (22) Date of filing: **20.08.1990**
- (51) Int Cl.⁶: **G06F 17/30, G06F 15/16**
- (86) International application number: **PCT/US90/04711**
- (87) International publication number: **WO 91/03788 (21.03.1991 Gazette 1991/07)**

(54) **PARALLEL I/O NETWORK FILE SERVER ARCHITECTURE**
DATEIENPROZESSORAUFBAU IM PARALLELEN EINGANGS/AUSGANGS NETZWERK
ARCHITECTURE DE SERVEUR DE FICHER, EN RESEAU ENTREE/SORTIE PARALLELE

- | | |
|-------------------------------------------------------------------------------------------------------------------------------------------------------------------------------------------------------------------------------------------------------------------------------------------------------------------------------------------------------------------------------------------------------------------------------------------------------------------------------------------------------------------------------------------------------------------------------------------------------------------------------|-------------------------------------------------------------------------------------------------------------------------------------------------------------------------------------------------------------------------------------------------------------------------------------------------------------------------------------------------------------------------------------------------------------------------------------------------------------------------------------------------------------------------------------------------------------------------------------------------------------------------------------------------------------------|
| <p>(84) Designated Contracting States:
AT BE CH DE DK ES FR GB IT LI LU NL SE</p> <p>(30) Priority: 08.09.1989 US 404959</p> <p>(43) Date of publication of application:
24.06.1992 Bulletin 1992/26</p> <p>(60) Divisional application: 97112889.7</p> <p>(73) Proprietor: AUSPEX SYSTEMS, INC.
Santa Clara, CA 95054 (US)</p> <p>(72) Inventors:
• ROW, Edward, John
Mountain View, CA 94064 (US)
• BOUCHER, Laurence, B.
Saratoga, CA 95070 (US)
• PITTS, William, M.
Los Altos, CA 94022 (US)</p> | <p>• BLIGHTMAN, Stephen, E.
San Jose, CA 95133 (US)</p> <p>(74) Representative: Barnard, Eric Edward et al
BROOKES & MARTIN
High Holborn House
52/54 High Holborn
London WC1V 6SE (GB)</p> <p>(56) References cited:
WO-A-89/03086 US-A- 4 710 868
US-A- 4 819 159 US-A- 4 887 204
US-A- 4 897 781</p> <p>• COMPUTER STANDARDS AND INTERFACES
vol. 8, no. 1, 1988, LAUSANNE CH pages 45 - 48
, XP51969 A.OSADZINSKI 'THE NETWORK FILE
SYSTEM (NFS)'</p> |
|-------------------------------------------------------------------------------------------------------------------------------------------------------------------------------------------------------------------------------------------------------------------------------------------------------------------------------------------------------------------------------------------------------------------------------------------------------------------------------------------------------------------------------------------------------------------------------------------------------------------------------|-------------------------------------------------------------------------------------------------------------------------------------------------------------------------------------------------------------------------------------------------------------------------------------------------------------------------------------------------------------------------------------------------------------------------------------------------------------------------------------------------------------------------------------------------------------------------------------------------------------------------------------------------------------------|

EP 0 490 973 B1

Note: Within nine months from the publication of the mention of the grant of the European patent, any person may give notice to the European Patent Office of opposition to the European patent granted. Notice of opposition shall be filed in a written reasoned statement. It shall not be deemed to have been filed until the opposition fee has been paid. (Art. 99(1) European Patent Convention).

Description

The present application is related to the following European Patent Applications:

- 5 1. MULTIPLE FACILITY -OPERATING SYSTEM ARCHITECTURE, Serial Number 90914006.3 (0490180), and
2. ENHANCED VMEBUS PROTOCOL UTILIZING PSEUDOSYNCHRONOUS HANDSHAKING AND BLOCK MODE DATA TRANSFER, Serial Number 90914333.1 (0490988).

10 BACKGROUND OF THE INVENTIONField of the Invention

15 The invention relates to computer data networks, and more particularly, to network file server architectures for computer networks.

Description of the Related Art

20 Over the past ten years, remarkable increases in hardware price/performance ratios have caused a startling shift in both technical and office computing environments. Distributed workstation-server networks are displacing the once pervasive dumb terminal attached to mainframe or minicomputer. To date, however, network I/O limitations have constrained the potential performance available to workstation users. This situation has developed in part because dramatic jumps in microprocessor performance have exceeded increases in network I/O performance.

25 In a computer network, individual user workstations are referred to as clients, and shared resources for filing, printing, data storage and wide-area communications are referred to as servers. Clients and servers are all considered nodes of a network. Client nodes use standard communications protocols to exchange service requests and responses with server nodes.

30 Present-day network clients and servers usually run the DOS, Macintosh OS, OS/2, or Unix operating systems. Local networks are usually Ethernet or Token Ring at the high end, Arcnet in the midrange, or LocalTalk or StarLAN at the low end. The client-server communication protocols are fairly strictly dictated by the operating system environment -- usually one of several proprietary schemes for PCs (NetWare, 3Plus, Vines, LANManager, LANServer); AppleTalk for Macintoshes; and TCP/IP with NFS or RFS for Unix. These protocols are all well-known in the industry.

35 Unix client nodes typically feature a 16- or 32-bit microprocessor with 1-8 MB of primary memory, a 640 x 1024 pixel display, and a built-in network interface. A 40-100 MB local disk is often optional. Low-end examples are 80286-based PCs or 68000-based Macintosh I's; mid-range machines include 80386 PCs, Macintosh II's, and 680X0-based Unix workstations; high-end machines include RISC-based DEC, HP, and Sun Unix workstations. Servers are typically nothing more than repackaged client nodes, configured in 19-inch racks rather than desk sideboxes. The extra space of a 19-inch rack is used for additional backplane slots, disk or tape drives, and power supplies.

40 Driven by RISC and CISC microprocessor developments, client workstation performance has increased by more than a factor of ten in the last few years. Concurrently, these extremely fast clients have also gained an appetite for data that remote servers are unable to satisfy. Because the I/O shortfall is most dramatic in the Unix environment, the description of the preferred embodiment of the present invention will focus on Unix file servers. The architectural principles that solve the Unix server I/O problem, however, extend easily to server performance bottlenecks in other operating system environments as well. Similarly, the description of the preferred embodiment will focus on Ethernet implementations, though the principles extend easily to other types of networks.

45 In most Unix environments, clients and servers exchange file data using the Network File System ("NFS"), a standard promulgated by Sun Microsystems and now widely adopted by the Unix community. NFS is defined in a document entitled, "NFS: Network File System Protocol Specification," Request For Comments (RFC) 1094, by Sun Microsystems, Inc. (March 1989).

50 While simple and reliable, NFS is not optimal. Clients using NFS place considerable demands upon both networks and NFS servers supplying clients with NFS data. This demand is particularly acute for so-called diskless clients that have no local disks and therefore depend on a file server for application binaries and virtual memory paging as well as data. For these Unix client-server configurations, the ten-to-one increase in client power has not been matched by a ten-to-one increase in Ethernet capacity, in disk speed, or server disk-to-network I/O throughput.

55 The result is that the number of diskless clients that a single modern high-end server can adequately support has dropped to between 5-10, depending on client power and application workload. For clients containing small local disks for applications and paging, referred to as dataless clients, the client-to-server ratio is about twice this, or between 10-20.

Such low client/server ratios cause piecewise network configurations in which each local Ethernet contains isolated traffic for its own 5-10 (diskless) clients and dedicated server. For overall connectivity, these local networks are usually joined together with an Ethernet backbone or, in the future, with an FDDI backbone. These backbones are typically connected to the local networks either by IP routers or MAC-level bridges, coupling the local networks together directly, or by a second server functioning as a network interface, coupling servers for all the local networks together.

In addition to performance considerations, the low client-to-server ratio creates computing problems in several additional ways:

1. Sharing. Development groups of more than 5-10 people cannot share the same server, and thus cannot easily share files without file replication and manual, multi-server updates. Bridges or routers are a partial solution but inflict a performance penalty due to more network hops.
2. Administration. System administrators must maintain many limited-capacity servers rather than a few more substantial servers. This burden includes network administration, hardware maintenance, and user account administration.
3. File System Backup. System administrators or operators must conduct multiple file system backups, which can be onerously time consuming tasks. It is also expensive to duplicate backup peripherals on each server (or every few servers if slower network backup is used).
4. Price Per Seat. With only 5-10 clients per server, the cost of the server must be shared by only a small number of users. The real cost of an entry-level Unix workstation is therefore significantly greater, often as much as 140% greater, than the cost of the workstation alone.

The widening I/O gap, as well as administrative and economic considerations, demonstrates a need for higher-performance, larger-capacity Unix file servers. Conversion of a display-less workstation into a server may address disk capacity issues, but does nothing to address fundamental I/O limitations. As an NFS server, the one-time workstation must sustain 5-10 or more times the network, disk, backplane, and file system throughput than it was designed to support as a client. Adding larger disks, more network adaptors, extra primary memory, or even a faster processor do not resolve basic architectural I/O constraints; I/O throughput does not increase sufficiently.

Other prior art computer architectures, while not specifically designed as file servers, may potentially be used as such. In one such well-known architecture, a CPU, a memory unit, and two I/O processors are connected to a single bus. One of the I/O processors operates a set of disk drives, and if the architecture is to be used as a server, the other I/O processor would be connected to a network. This architecture is not optimal as a file server, however, at least because the two I/O processors cannot handle network file requests without involving the CPU. All network file requests that are received by the network I/O processor are first transmitted to the CPU, which makes appropriate requests to the disk-I/O processor for satisfaction of the network request.

In another such computer architecture, a disk controller CPU manages access to disk drives, and several other CPUs, three for example, may be clustered around the disk controller CPU. Each of the other CPUs can be connected to its own network. The network CPUs are each connected to the disk controller CPU as well as to each other for interprocessor communication. One of the disadvantages of this computer architecture is that each CPU in the system runs its own complete operating system. Thus, network file server requests must be handled by an operating system which is also heavily loaded with facilities and processes for performing a large number of other, non file-server tasks. Additionally, the interprocessor communication is not optimized for file server type requests.

In yet another computer architecture, a plurality of CPUs, each having its own cache memory for data and instruction storage, are connected to a common bus with a system memory and a disk controller. The disk controller and each of the CPUs have direct memory access to the system memory, and one or more of the CPUs can be connected to a network. This architecture is disadvantageous as a file server because, among other things, both file data and the instructions for the CPUs reside in the same system memory. There will be instances, therefore, in which the CPUs must stop running while they wait for large blocks of file data to be transferred between the system memory and the network CPU. Additionally, as with both of the previously described computer architectures, the entire operating system runs on each of the CPUs, including the network CPU.

In yet another type of computer architecture, a large number of CPUs are connected together in a hypercube topology. One or more of these CPUs can be connected to networks, while another can be connected to disk drives. This architecture is also disadvantageous as a file server because, amongst other things each processor runs the entire operating system. Interprocessor communication is also not optimal for file server applications.

US-A-4819159 describes a data control unit for use with a data network which employs a mass storage device, a file processor, a buffer memory with a cache and a storage processor unit coupleable to the mass storage device and the file processor. The file processor serves to translate file system requests into store and retrieval requests activated in the mass storage device.

WO-A-89/03086 describes a network composed of a plurality of PC's linked to a main frame computer with a data

base via a number of intermediate computers. The intermediate computers serve to respond to network file requests and to additionally provide resources for the PC's.

An article entitled 'The Network File System' (NFS) by A. Osadzinski published in Computer Standards and Interfaces Vol. 8 (1988/89) No. 1 describes a NFS protocol which provides transparent file access for client work stations from a file server with a mass storage device and a host processor linked together with a network.

SUMMARY OF THE INVENTION

As is known, for example from WO-A-89/03086, the present invention provides a network server apparatus for use with a first data network and a mass storage device, including a host processor unit capable of running remote procedures defined by a client node on said network.

In accordance with the invention, the apparatus comprises an interface processor unit coupleable to the network and to the mass storage device and means in said interface processor unit for satisfying network storage requests from said network to store data from said network in said mass storage device, for satisfying network retrieval requests from said network to retrieve data from said mass storage device to said network, and for transmitting predefined categories of messages from said network to said host processor unit for processing in said host processor unit, said transmitted messages including all requests by a network client to run client-defined procedures on said network server apparatus.

An implementation of the invention involves a file server architecture comprising one or more network controllers, one or more file controllers, one or more storage processors, and a system or buffer memory, all connected over a message passing bus and operating in parallel with a Unix host processor. The network controllers each connect to one or more network, and provide all protocol processing between the network layer data format and an internal file server format for communicating client requests to other processors in the server. Only those data packets which cannot be interpreted by the network controllers, for example client requests to run a client-defined program on the server, are transmitted to the Unix host for processing. Thus the network controllers, file controllers and storage processors contain only small parts of an overall operating system, and each is optimized for the particular type of work to which it is dedicated.

Client requests for file operations are transmitted to one of the file controllers which, independently of the Unix host, manages the virtual file system of a mass storage device which is coupled to the storage processors. The file controllers may also control data buffering between the storage processors and the network controllers, through the system memory. The file controllers preferably each include a local buffer memory for caching file control information, separate from the system memory for caching file data. Additionally, the network controllers, file processors and storage processors are all designed to avoid any instruction fetches from the system memory, instead keeping all instruction memory separate and local. This arrangement eliminates contention on the backplane between microprocessor instruction fetches and transmissions of message and file data.

BRIEF DESCRIPTION OF THE DRAWINGS

The invention will be described with respect to particular embodiments thereof, and reference will be made to the drawings, in which:

Fig. 1. is a block diagram of a prior art file server architecture;

Fig. 2 is a block diagram of a file server architecture according to the invention;

Fig. 3 is a block diagram of one of the network controllers shown in Fig. 2;

Fig. 4 is a block diagram of one of the file controllers shown in Fig. 2;

Fig. 5 is a block diagram of one of the storage processors shown in Fig. 2;

Fig. 6 is a block diagram of one of the system memory cards shown in Fig. 2;

Figs. 7A-C are a flowchart illustrating the operation of a fast transfer protocol BLOCK WRITE cycle; and

Figs. 8A-C are a flowchart illustrating the operation of a fast transfer protocol BLOCK READ cycle.

DETAILED DESCRIPTION

For comparison purposes and background, an illustrative prior-art file server architecture will first be described with respect to Fig. 1. Fig. 1 is an overall block diagram of a conventional prior-art Unix-based file server for Ethernet networks. It consists of a host CPU card 10 with a single microprocessor on board. The host CPU card 10 connects to an Ethernet #1 12, and it connects via a memory management unit (MMU) 11 to a large memory array 16. The host CPU card 10 also drives a keyboard, a video display, and two RS232 ports (not shown). It also connects via the MMU 11 and a standard 32-bit VME bus 20 to various peripheral devices, including an SMD disk controller 22 controlling

one or two disk drives 24, a SCSI host adaptor 26 connected to a SCSI bus 28, a tape controller 30 connected to a quarter-inch tape drive 32, and possibly a network #2 controller 34 connected to a second Ethernet 36. The SMD disk controller 22 can communicate with memory array 16 by direct memory access via bus 20 and MMU 11, with either the disk controller or the MMU acting as a bus master. This configuration is illustrative; many variations are available.

5 The system communicates over the Ethernets using industry standard TCP/IP and NFS protocol stacks. A description of protocol stacks in general can be found in Tanenbaum, "Computer Networks" (Second Edition, Prentice Hall: 1988). File server protocol stacks are described at pages 535-546.

Basically, the following protocol layers are implemented in the apparatus of Fig. 1:

10 Network Layer. The network layer converts data packets between a format specific to Ethernets and a format which is independent of the particular type of network used. The Ethernet-specific format which is used in the apparatus of Fig. 1 is described in Hornig, "A Standard For The Transmission of IP Datagrams Over Ethernet Networks," RFC 894 (April 1984).

15 The Internet Protocol (IP) Layer. This layer provides the functions necessary to deliver a package of bits (an internet datagram) from a source to a destination over an interconnected system of networks. For messages to be sent from the file server to a client, a higher level in the server calls the IP module, providing the internet address of the destination client and the message to transmit. The IP module performs any required fragmentation of the message to accommodate packet size limitations of any intervening gateway, adds internet headers to each fragment, and calls on the network layer to transmit the resulting internet datagrams. The internet header includes a local network destination address (translated from the internet address) as well as other parameters.

20 For messages received by the IP layer from the network layer, the IP module determines from the internet address whether the datagram is to be forwarded to another host on another network, for example on a second Ethernet such as 36 in Fig. 1, or whether it is intended for the server itself. If it is intended for another host on the second network, the IP module determines a local net address for the destination and calls on the local network layer for that network to send the datagram. If the datagram is intended for an application program within the server, the IP layer strips off the header and passes the remaining portion of the message to the appropriate next higher layer. The internet protocol standard used in the illustrative apparatus of Fig. 1 is specified in Information Sciences Institute, "Internet Protocol, DARPA Internet Program Protocol Specification," RFC 791 (September 1981).

25 TCP/UDP Layer. This layer is a datagram service with more elaborate packaging and addressing options than the IP layer. For example, whereas an IP datagram can hold about 1,500 bytes and be addressed to hosts, UDP datagrams can hold about 64KB and be addressed to a particular port within a host. TCP and UDP are alternative protocols at this layer; applications requiring ordered reliable delivery of streams of data may use TCP, whereas applications (such as NFS) which do not require ordered and reliable delivery may use UDP.

30 The prior art file server of Fig. 1 uses both TCP and UDP. It uses UDP for file server-related services, and uses TCP for certain other services which the server provides to network clients. The UDP is specified in Postel, "User Datagram Protocol," RFC 768 (August 28, 1980). TCP is specified in Postel, "Transmission Control Protocol," RFC 761 (January 1980) and RFC 793 (September 1981).

35 XDR/RPC Layer. This layer provides functions callable from higher level programs to run a designated procedure on a remote machine. It also provides the decoding necessary to permit a client machine to execute a procedure on the server. For example, a caller process in a client node may send a call message to the server of Fig. 1. The call message includes a specification of the desired procedure, and its parameters. The message is passed up the stack to the RPC layer, which calls the appropriate procedure within the server. When the procedure is complete, a reply message is generated and RPC passes it back down the stack and over the network to the caller client. RPC is described in Sun Microsystems, Inc., "RPC: Remote Procedure Call Protocol Specification, Version 2," RFC 1057 (June 1988).

40 RPC uses the XDR external data representation standard to represent information passed to and from the underlying UDP layer. XDR is merely a data encoding standard, useful for transferring data between different computer architectures. Thus, on the network side of the XDR/RPC layer, information is machine-independent; on the host application side, it may not be. XDR is described in Sun Microsystems, Inc., "XDR: External Data Representation Standard," RFC 1014 (June 1987).

45 NFS Layer. The NFS ("network file system") layer is one of the programs available on the server which an RPC request can call. The combination of host address, program number, and procedure number in an RPC request can specify one remote NFS procedure to be called.

50 Remote procedure calls to NFS on the file server of Fig. 1 provide transparent, stateless, remote access to shared files on the disks 24. NFS assumes a file system that is hierarchical, with directories at all but the bottom level of files. Client hosts can call any of about 20 NFS procedures including such procedures as reading a specified number of bytes from a specified file; writing a specified number of bytes to a specified file; creating, renaming and removing specified files; parsing directory trees; creating and removing directories; and reading and setting file attributes. The location on disk to which and from which data is stored and retrieved is always specified in logical terms, such as by a file handle or inode designation and a byte offset. The details of the actual data storage are hidden from the client.

The NFS procedures, together with possible higher level modules such as Unix VFS and UFS, perform all conversion of logical data addresses to physical data addresses such as drive, head, track and sector identification. NFS is specified in Sun Microsystems, Inc., "NFS: Network File System Protocol Specification," RFC 1094 (March 1989).

5 With the possible exception of the network layer, all the protocol processing described above is done in software, by a single processor in the host CPU card 10. That is, when an Ethernet packet arrives on Ethernet 12, the host CPU 10 performs all the protocol processing in the NFS stack, as well as the protocol processing for any other application which may be running on the host 10. NFS procedures are run on the host CPU 10, with access to memory 16 for both data and program code being provided via MMU 11. Logically specified data addresses are converted to a much more physically specified form and communicated to the SMD disk controller 22 or the SCSI bus 28, via the VME bus 20, and all disk caching is done by the host CPU 10 through the memory 16. The host CPU card 10 also runs procedures 10 for performing various other functions of the file server, communicating with tape controller 30 via the VME bus 20. Among these are client-defined remote procedures requested by client workstations.

If the server serves a second Ethernet 36, packets from that Ethernet are transmitted to the host CPU 10 over the same VME bus 20 in the form of IP datagrams. Again, all protocol processing except for the network layer is performed 15 by software processes running on the host CPU 10. In addition, the protocol processing for any message that is to be sent from the server out on either of the Ethernets 12 or 36 is also done by processes running on the host CPU 10.

It can be seen that the host CPU 10 performs an enormous amount of processing of data, especially if 5-10 clients on each of the two Ethernets are making file server requests and need to be sent responses on a frequent basis. The host CPU 10 runs a multitasking Unix operating system, so each incoming request need not wait for the previous request to be completely processed and returned before being processed. Multiple processes are activated on the 20 host CPU 10 for performing different stages of the processing of different requests, so many requests may be in process at the same time. But there is only one CPU on the card 10, so the processing of these requests is not accomplished in a truly parallel manner. The processes are instead merely time sliced. The CPU 10 therefore represents a major bottleneck in the processing of file server requests.

25 Another bottleneck occurs in MMU 11, which must transmit both instructions and data between the CPU card 10 and the memory 16. All data flowing between the disk drives and the network passes through this interface at least twice.

Yet another bottleneck can occur on the VME bus 20, which must transmit data among the SMD disk controller 22, the SCSI host adaptor 26, the host CPU card 10, and possibly the network #2 controller 24.

30 PREFERRED EMBODIMENT-OVERALL HARDWARE ARCHITECTURE

In Fig. 2 there is shown a block diagram of a network file server 100 according to the invention. It can include multiple network controller (NC) boards, one or more file controller (FC) boards, one or more storage processor (SP) boards, multiple system memory boards, and one or more host processors. The particular embodiment shown in Fig. 35 2 includes four network controller boards 110a-110d, two file controller boards 112a-112b, two storage processors 114a-114b, four system memory cards 116a-116d for a total of 192MB of memory, and one local host processor 118. The boards 110, 112, 114, 116 and 118 are connected together over a VME bus 120 on which an enhanced block transfer mode as described in the ENHANCED VMEBUS PROTOCOL application identified above may be used. Each of the four network controllers 110 shown in Fig. 2 can be connected to up to two Ethernets 122, for a total capacity 40 of 8 Ethernets 122a-122h. Each of the storage processors 114 operates ten parallel SCSI busses, nine of which can each support up to three SCSI disk drives each. The tenth SCSI channel on each of the storage processors 114 is used for tape drives and other SCSI peripherals.

The host 118 is essentially a standard SunOs Unix processor, providing all the standard Sun Open Network Computing (ONC) services except NFS and IP routing. Importantly, all network requests to run a user-defined procedure 45 are passed to the host for execution. Each of the NC boards 110, the FC boards 112 and the SP boards 114 includes its own independent 32-bit microprocessor. These boards essentially offload from the host processor 118 virtually all of the NFS and disk processing. Since the vast majority of messages to and from clients over the Ethernets 122 involve NFS requests and responses, the processing of these requests in parallel by the NC, FC and SP processors, with minimal involvement by the local host 118, vastly improves file server performance. Unix is explicitly eliminated from 50 virtually all network, file, and storage processing.

OVERALL SOFTWARE ORGANIZATION AND DATA FLOW

Prior to a detailed discussion of the hardware subsystems shown in Fig. 2, an overview of the software structure 55 will now be undertaken. The software organization is described in more detail in the above-identified application entitled MULTIPLE FACILITY OPERATING SYSTEM ARCHITECTURE.

Most of the elements of the software are well known in the field and are found in most networked Unix systems, but there are two components which are not: Local NFS ("LNFS") and the messaging kernel ("MK") operating system

kernel. These two components will be explained first.

The Messaging Kernel. The various processors in file server 100 communicate with each other through the use of a messaging kernel running on each of the processors 110, 112, 114 and 118. These processors do not share any instruction memory, so task-level communication cannot occur via straightforward procedure calls as it does in conventional Unix. Instead, the messaging kernel passes messages over VME bus 120 to accomplish all necessary inter-processor communication. Message passing is preferred over remote procedure calls for reasons of simplicity and speed.

Messages passed by the messaging kernel have a fixed 128-byte length. Within a single processor, messages are sent by reference; between processors, they are copied by the messaging kernel and then delivered to the destination process by reference. The processors of Fig. 2 have special hardware, discussed below, that can expediently exchange and buffer inter-processor messaging kernel messages.

The LNFS Local NFS interface. The 22-function NFS standard was specifically designed for stateless operation using unreliable communication. This means that neither clients nor server can be sure if they hear each other when they talk (unreliability). In practice, an in an Ethernet environment, this works well.

Within the server 100, however, NFS level datagrams are also used for communication between processors, in particular between the network controllers 110 and the file controller 112, and between the host processor 118 and the file controller 112. For this internal communication to be both efficient and convenient, it is undesirable and impractical to have complete statelessness or unreliable communications. Consequently, a modified form of NFS, namely LNFS, is used for internal communication of NFS requests and responses. LNFS is used only within the file server 100; the external network protocol supported by the server is precisely standard, licensed NFS. LNFS is described in more detail below.

The Network Controllers 110 each run an NFS server which, after all protocol processing is done up to the NFS layer, converts between external NFS requests and responses and internal LNFS requests and responses. For example, NFS requests arrive as RPC requests with XDR and enclosed in a UDP datagram. After protocol processing, the NFS server translates the NFS request into LNFS form and uses the messaging kernel to send the request to the file controller 112.

The file controller runs an LNFS server which handles LNFS requests both from network controllers and from the host 118. The LNFS server translates LNFS requests to a form appropriate for a file system server, also running on the file controller, which manages the system memory file data cache through a block I/O layer.

An overview of the software in each of the processors will now be set forth.

Network Controller 110

The optimized dataflow of the server 100 begins with the intelligent network controller 110. This processor receives Ethernet packets from client workstations. It quickly identifies NFS-destined packets and then performs full protocol processing on them to the NFS level, passing the resulting LNFS requests directly to the file controller 112. This protocol processing includes IP routing and reassembly, UDP demultiplexing, XDR decoding, and NFS request dispatching. The reverse steps are used to send an NFS reply back to a client. Importantly, these time-consuming activities are performed directly in the Network Controller 110, not in the host 118.

The server 100 uses conventional NFS ported from Sun Microsystems, Inc., Mountain View, CA, and is NFS protocol compatible.

Non-NFS network traffic is passed directly to its destination host processor 118.

The NCs 110 also perform their own IP routing. Each network controller 110 supports two fully parallel Ethernets. There are four network controllers in the embodiment of the server 100 shown in Fig. 2, so that server can support up to eight Ethernets. For the two Ethernets on the same network controller 110, IP routing occurs completely within the network controller and generates no backplane traffic. Thus attaching two mutually active Ethernets to the same controller not only minimizes their internet transit time, but also significantly reduces backplane contention on the VME bus 120. Routing table updates are distributed to the network controllers from the host processor 118, which runs either the gated or routed Unix demon.

While the network controller described here is designed for Ethernet LANs, it will be understood that the invention can be used just as readily with other network types, including FDDI.

File Controller 112

In addition to dedicating a separate processor for NFS protocol processing and IP routing, the server 100 also dedicates a separate processor, the intelligent file controller 112, to be responsible for all file system processing. It uses conventional Berkeley Unix 4.3 file system code and uses a binary-compatible data representation on disk. These two choices allow all standard file system utilities (particularly block-level tools) to run unchanged.

The file controller 112 runs the shared file system used by all NCs 110 and the host processor 118. Both the NCs and the host processor communicate with the file controller 112 using the LNFS interface. The NCs 110 use LNFS as described above, while the host processor 118 uses LNFS as a plug-in module to SunOs's standard Virtual File System ("VFS") interface.

5 When an NC receives an NFS read request from a client workstation, the resulting LNFS request passes to the FC 112. The FC 112 first searches the system memory 116 buffer cache for the requested data. If found, a reference to the buffer is returned to the NC 110. If not found, the LRU (least recently used) cache buffer in system memory 116 is freed and reassigned for the requested block. The FC then directs the SP 114 to read the block into the cache buffer from a disk drive array. When complete, the SP so notifies the FC, which in turn notifies the NC 100. The NC 110 then
10 sends an NFS reply, with the data from the buffer, back to the NFS client workstation out on the network. Note that the SP 114 transfers the data into system memory 116, if necessary, and the NC 110 transferred the data from system memory 116 to the networks. The process takes place without any involvement of the host 118.

Storage Processor

15 The intelligent storage processor 114 manages all disk and tape storage operations. While autonomous, storage processors are primarily directed by the file controller 112 to move file data between system memory 116 and the disk subsystem. The exclusion of both the host 118 and the FC 112 from the actual data path helps to supply the performance needed to service many remote clients.

20 Additionally, coordinated by a Server Manager in the host 118, storage processor 114 can execute server backup by moving data between the disk subsystem and tape or other archival peripherals on the SCSI channels. Further, if directly accessed by host processor 118, SP 114 can provide a much higher performance conventional disk interface for Unix, virtual memory, and databases. In Unix nomenclature, the host processor 118 can mount boot, storage swap, and raw partitions via the storage processors 114.

25 Each storage processor 114 operates ten parallel, fully synchronous SCSI channels (busses) simultaneously. Nine of these channels support three arrays of nine SCSI disk drives each, each drive in an array being assigned to a different SCSI channel. The tenth SCSI channel hosts up to seven tape and other SCSI peripherals. In addition to performing reads and writes, SP 114 performs device-level optimizations such as disk seek queue sorting, directs device error recovery, and controls DMA transfers between the devices and system memory 116.
30

Host Processor 118

The local host 118 has three main purposes: to run Unix, to provide standard ONC network services for clients, and to run a Server Manager. Since Unix and ONC are ported from the standard SunOs Release 4 and ONC Services Release 2, the server 100 can provide identically compatible high-level ONC services such as the Yellow Pages, Lock Manager, DES Key Authenticator, Auto Mounter, and Port Mapper. Sun/2 Network disk booting and more general IP internet services such as Telnet, FTP, SMTP, SNMP, and reverse ARP are also supported. Finally, print spoolers and similar Unix demons operate transparently.
35

The host processor 118 runs the following software modules:
40 TCP and socket layers. The Transport Control Protocol ("TCP"), which is used for certain server functions other than NFS, provides reliable bytestream communication between two processors. Socket are used to establish TCP connections.

VFS interface. The Virtual File System ("VFS") interface is a standard SunOs file system interface. It paints a uniform file-system picture for both users and the non-file parts of the Unix operating system, hiding the details of the specific file system. Thus standard NFS, LNFS, and any local Unix file system can coexist harmoniously.
45

UFS interface. The Unix File System ("UFS") interface is the traditional and well-known Unix interface for communication with local-to-the-processor disk drives: In the server 100, it is used to occasionally mount storage processor volumes directly, without going through the file controller 112. Normally, the host 118 uses LNFS and goes through the file controller.
50

Device layer. The device layer is a standard software interface between the Unix device model and different physical device implementations. In the server 100, disk devices are not attached to host processors directly, so the disk driver in the host's device layer uses the messaging kernel to communicate with the storage processor 114.

Route and Port Mapper Demons. The Route and Port Mapper demons are Unix user-level background processes that maintain the Route and Port databases for packet routing. They are mostly inactive and not in any performance path.
55

Yellow Pages and Authentication Demon. The Yellow Pages and Authentication services are Sun-ONC standard network services. Yellow Pages is a widely used multipurpose name-to-name directory lookup service. The Authentication service uses cryptographic keys to authenticate, or validate, requests to insure that requestors have the proper

privileges for any actions or data they desire.

Server Manager. The Server Manager is an administrative application suite that controls configuration, logs error and performance reports, and provides a monitoring and tuning interface for the system administrator. These functions can be exercised from either system console connected to the host 118, or from a system administrator's workstation.

5 The host processor 118 is a conventional OEM Sun central processor card, Model 3E/120. It incorporates a Motorola 68020 microprocessor and 4MB of on-board memory. Other processors, such as a SPARC-based processor, are also possible.

The structure and operation of each of the hardware components of server 100 will now be described in detail.

10 NETWORK CONTROLLER HARDWARE ARCHITECTURE

Fig. 3 is a block diagram showing the data path and some control paths for an illustrative one of the network controllers 110a. It comprises a 20 MHz 68020 microprocessor 210 connected to a 32-bit microprocessor data bus 212. Also connected to the microprocessor data bus 212 is a 256K byte CPU memory 214. The low order 8 bits of the microprocessor data bus 212 are connected through a bidirectional buffer 216 to an 8-bit slow-speed data bus 218. On the slow-speed data bus 218 is a 128K byte EPROM 220, a 32 byte PROM 222, and a multi-function peripheral (MFP) 224. The EPROM 220 contains boot code for the network controller 110a, while the PROM 222 stores various operating parameters such as the Ethernet addresses assigned to each of the two Ethernet interfaces on the board. Ethernet address information is read into the corresponding interface control block in the CPU memory 214 during initialization. The MFP 224 is a Motorola 68901, and performs various local functions such as timing, interrupts, and general purpose I/O. The MFP 224 also includes a UART for interfacing to an RS232 port 226. These functions are not critical to the invention and will not be further described herein.

The low order 16 bits of the microprocessor data bus 212 are also coupled through a bidirectional buffer 230 to a 16-bit LAN data bus 232. A LAN controller chip 234, such as the Am7990 LANCE Ethernet controller manufactured by Advanced Micro Devices, Inc. Sunnyvale, CA., interfaces the LAN data bus 232 with the first Ethernet 122a shown in Fig. 2. Control and data for the LAN controller 234 are stored in a 512K byte LAN memory 236, which is also connected to the LAN data bus 232. A specialized 16 to 32 bit FIFO chip 240, referred to herein as a parity FIFO chip and described below, is also connected to the LAN data bus 232. Also connected to the LAN data bus 232 is a LAN DMA controller 242, which controls movements of packets of data between the LAN memory 236 and the FIFO chip 240. The LAN DMA controller 242 may be a Motorola M68440 DMA controller using channel zero only.

The second Ethernet 122b shown in Fig. 2 connects to a second LAN data bus 252 on the network controller card 110a shown in Fig. 3. The LAN data bus 252 connects to the low order 16 bits of the microprocessor data bus 212 via a bidirectional buffer 250, and has similar components to those appearing on the LAN data bus 232. In particular, a LAN controller 254 interfaces the LAN data bus 252 with the Ethernet 122b, using LAN memory 256 for data and control, and a LAN DMA controller 262 controls DMA transfer of data between the LAN memory 256 and the 16-bit wide data port A of the parity FIFO 260.

The low order 16 bits of microprocessor data bus 212 are also connected directly to another parity FIFO 270, and also to a control port of a VME/FIFO DMA controller 272. The FIFO 270 is used for passing messages between the CPU memory 214 and one of the remote boards 110, 112, 114, 116 or 118 (Fig. 2) in a manner described below. The VME/FIFO DMA controller 272, which supports three round-robin non-prioritized channels for copying data, controls all data transfers between one of the remote boards and any of the FIFOs 240, 260 or 270, as well as between the FIFOs 240 and 260.

32-bit data bus 274, which is connected to the 32-bit port B of each of the FIFOs 240, 260 and 270, is the data bus over which these transfers take place. Data bus 274 communicates with a local 32-bit bus 276 via a bidirectional pipelining latch 278, which is also controlled by VME/FIFO DMA controller 272, which in turn communicates with the VME bus 120 via a bidirectional buffer 280.

The local data bus 276 is also connected to a set of control registers 282, which are directly addressable across the VME bus 120. The registers 282 are used mostly for system initialization and diagnostics.

The local data bus 276 is also coupled to the microprocessor data bus 212 via a bidirectional buffer 284. When the NC 110a operates in slave mode, the CPU memory 214 is directly addressable from VME bus 120. One of the remote boards can copy data directly from the CPU memory 214 via the bidirectional buffer 284. LAN memories 236 and 256 are not directly addressed over VME bus 120.

The parity FIFOs 240, 260 and 270 each consist of an ASIC, the functions and operation of which are described in the Appendix. The FIFOs 240 and 260 are configured for packet data transfer and the FIFO 270 is configured for message passing. Referring to the Appendix, the FIFOs 240 and 260 are programmed with the following bit settings in the Data Transfer Configuration Register:

EP 0 490 973 B1

Bit	Definition	Setting
0	WD Mode	N/A
1	Parity Chip	N/A
2	Parity Correct Mode	N/A
3	8/16 bits CPU & PortA interface	16 bits(1)
4	Invert Port A address 0	no (0)
5	Invert Port A address 1	yes (1)
6	Checksum Carry Wrap	yes (1)
7	Reset	no (0)

The Data Transfer Control Register is programmed as follows:

Bit	Definition	Setting
0	Enable PortA Req/Ack	yes (1)
1	Enable PortB Req/Ack	yes (1)
2	Data Transfer Direction	(as desired)
3	CPU parity enable	no (0)
4	PortA parity enable	no (0)
5	PortB parity enable	no (0)
6	Checksum Enable	yes (1)
7	PortA Master	yes (1)

Unlike the configuration used on FIFOs 240 and 260, the microprocessor 210 is responsible for loading and unloading Port A directly. The microprocessor 210 reads an entire 32-bit word from port A with a single instruction using two port A access cycles. Port A data transfer is disabled by unsetting bits 0 (Enable PortA Req/Ack) and 7 (PortA Master) of the Data Transfer Control Register.

The remainder of the control settings in FIFO 270 are the same as those in FIFOs 240 and 260 described above.

The NC 110a also includes a command FIFO 290. The command FIFO 290 includes an input port coupled to the local data bus 276, and which is directly addressable across the VME bus 120, and includes an output port connected to the microprocessor data bus 212. As explained in more detail below, when one of the remote boards issues a command or response to the NC 110a, it does so by directly writing a 1-word (32-bit) message descriptor into NC 110a's command FIFO 290. Command FIFO 290 generates a "FIFO not empty" status to the microprocessor 210, which then reads the message descriptor off the top of FIFO 290 and processes it. If the message is a command, then it includes a VME address at which the message is located (presumably an address in a shared memory similar to 214 on one of the remote boards). The microprocessor 210 then programs the FIFO 270 and the VME/FIFO DMA controller 272 to copy the message from the remote location into the CPU memory 214.

Command FIFO 290 is a conventional two-port FIFO, except that additional circuitry is included for generating a Bus Error signal on VME bus 120 if an attempt is made to write to the data input port while the FIFO is full. Command FIFO 290 has space for 256 entries.

A noteworthy feature of the architecture of NC 110a is that the LAN buses 232 and 252 are independent of the microprocessor data bus 212. Data packets being routed to or from an Ethernet are stored in LAN memory 236 on the LAN data bus 232 (or 256 on the LAN data bus 252), and not in the CPU memory 214. Data transfer between the LAN memories 236 and 256 and the Ethernets 122a and 122b, are controlled by LAN controllers 234 and 254, respectively, while most data transfer between LAN memory 236 or 256 and a remote port on the VME bus 120 are controlled by LAN DMA controllers 242 and 262, FIFOs 240 and 260, and VME/FIFO DMA controller 272. An exception to this rule occurs when the size of the data transfer is small, e.g., less than 64 bytes, in which case microprocessor 210 copies it directly without using DMA. The microprocessor 210 is not involved in larger transfers except in initiating them and in receiving notification when they are complete.

The CPU memory 214 contains mostly instructions for microprocessor 210, messages being transmitted to or from a remote board via FIFO 270, and various data blocks for controlling the FIFOs, the DMA controllers and the LAN controllers. The microprocessor 210 accesses the data packets in the LAN memories 236 and 256 by directly addressing them through the bidirectional buffers 230 and 250, respectively, for protocol processing. The local high-speed static RAM in CPU memory 214 can therefore provide zero wait state memory access for microprocessor 210 independent of network traffic. This is in sharp contrast to the prior art architecture shown in Fig. 1, in which all data and

data packets, as well as microprocessor instructions for host CPU card 10, reside in the memory 16 and must communicate with the host CPU card 10 via the MMU 11.

While the LAN data buses 232 and 252 are shown as separate buses in Fig. 3, it will be understood that they may instead be implemented as a single combined bus.

NETWORK CONTROLLER OPERATION

In operation, when one of the LAN controllers (such as 234) receives a packet of information over its Ethernet 122a, it reads in the entire packet and stores it in corresponding LAN memory 236. The LAN controller 234 then issues an interrupt to microprocessor 210 via MFP 224, and the microprocessor 210 examines the status register on LAN controller 234 (via bidirectional buffer 230) to determine that the event causing the interrupt was a "receive packet completed." In order to avoid a potential lockout of the second Ethernet 122b caused by the prioritized interrupt handling characteristic of MFP 224, the microprocessor 210 does not at this time immediately process the received packet; instead, such processing is scheduled for a polling function.

When the polling function reaches the processing of the received packet, control over the packet is passed to a software link level receive module. The link level receive module then decodes the packet according to either of two different frame formats: standard Ethernet format or SNAP (IEEE 802 LCC) format. An entry in the header in the packet specifies which frame format was used. The link level driver then determines which of three types of messages is contained in the received packet: (1) IP, (2) ARP packets which can be handled by a local ARP module, or (3) ARP packets and other packet types which must be forwarded to the local host 118 (Fig. 2) for processing. If the packet is an ARP packet which can be handled by the NC 110a, such as a request for the address of server 100, then the microprocessor 210 assembles a response packet in LAN memory 236 and, in a conventional manner, causes LAN controller 234 to transmit that packet back over Ethernet 122a. It is noteworthy that the data manipulation for accomplishing this task is performed almost completely in LAN memory 236, directly addressed by microprocessor 210 as controlled by instructions in CPU memory 214. The function is accomplished also without generating any traffic on the VME backplane 120 at all, and without disturbing the local host 118.

If the received packet is either an ARP packet which cannot be processed completely in the NC 110a, or is another type of packet which requires delivery to the local host 118 (such as a client request for the server 100 to execute a client-defined procedure), then the microprocessor 210 programs LAN DMA controller 242 to load the packet from LAN memory 236 into FIFO 240, programs FIFO 240 with the direction of data transfer, and programs DMA controller 272 to read the packet out of FIFO 240 and across the VME bus 120 into system memory 116. In particular, the microprocessor 210 first programs the LAN DMA controller 242 with the starting address and length of the packet in LAN memory 236, and programs the controller to begin transferring data from the LAN memory 236 to port A of parity FIFO 240 as soon as the FIFO is ready to receive data. Second, microprocessor 210 programs the VME/FIFO DMA controller 272 with the destination address in system memory 116 and the length of the data packet, and instructs the controller to begin transferring data from port B of the FIFO 260 onto VME bus 120. Finally, the microprocessor 210 programs FIFO 240 with the direction of the transfer to take place. The transfer then proceeds entirely under the control of DMA controllers 242 and 272, without any further involvement by microprocessor 210.

The microprocessor 210 then sends a message to host 118 that a packet is available at a specified system memory address. The microprocessor 210 sends such a message by writing a message descriptor to a software-emulated command FIFO on the host, which copies the message from CPU memory 214 on the NC via buffer 284 and into the host's local memory, in ordinary VME block transfer mode. The host then copies the packet from system memory 116 into the host's own local memory using ordinary VME transfers.

If the packet received by NC 110a from the network is an IP packet, then the microprocessor 210 determines whether it is (1) an IP packet for the server 100 which is not an NFS packet; (2) an IP packet to be routed to a different network; or (3) an NFS packet. If it is an IP packet for the server 100, but not an NFS packet, then the microprocessor 210 causes the packet to be transmitted from the LAN memory 236 to the host 118 in the same manner described above with respect to certain ARP packets.

If the IP packet is not intended for the server 100, but rather is to be routed to a client on a different network, then the packet is copied into the LAN memory associated with the Ethernet to which the destination client is connected. If the destination client is on the Ethernet 122b, which is on the same NC board as the source Ethernet 122a, then the microprocessor 210 causes the packet to be copied from LAN memory 236 into LAN 256 and then causes LAN controller 254 to transmit it over Ethernet 122b. (Of course, if the two LAN data buses 232 and 252 are combined, then copying would be unnecessary; the microprocessor 210 would simply cause the LAN controller 254 to read the packet out of the same locations in LAN memory to which the packet was written by LAN controller 234.)

The copying of a packet from LAN memory 236 to LAN memory 256 takes place similarly to the copying described above from LAN memory to system memory. For transfer sizes of 64 bytes or more, the microprocessor 210 first programs the LAN DMA controller 242 with the starting address and length of the packet in LAN memory 236, and

programs the controller to begin transferring data from the LAN memory 236 into port A of parity FIFO 240 as soon as the FIFO is ready to receive data. Second, microprocessor 210 programs the LAN DMA controller 262 with a destination address in LAN memory 256 and the length of the data packet, and instructs that controller to transfer data from parity FIFO 260 into the LAN memory 256. Third, microprocessor 210 programs the VME/FIFO DMA controller 272 to clock words of data out of port B of the FIFO 240, over the data bus 274, and into port B of FIFO 260. Finally, the microprocessor 210 programs the two FIFOs 240 and 260 with the direction of the transfer to take place. The transfer then proceeds entirely under the control of DMA controllers 242, 262 and 272, without any further involvement by the microprocessor 210. Like the copying from LAN memory to system memory, if the transfer size is smaller than 64 bytes, the microprocessor 210 performs the transfer directly, without DMA.

When each of the LAN DMA controllers 242 and 262 complete their work, they so notify microprocessor 210 by a respective interrupt provided through MFP 224. When the microprocessor 210 has received both interrupts, it programs LAN controller 254 to transmit the packet on the Ethernet 122b in a conventional manner.

Thus, IP routing between the two Ethernets in a single network controller 110 takes place over data bus 274, generating no traffic over VME bus 120. Nor is the host processor 118 disturbed for such routing, in contrast to the prior art architecture of Fig. 1. Moreover, all but the shortest copying work is performed by controllers outside microprocessor 210, requiring the involvement of the microprocessor 210, and bus traffic on microprocessor data bus 212, only for the supervisory functions of programming the DMA controllers and the parity FIFOs and instructing them to begin. The VME/FIFO DMA controller 272 is programmed by loading control registers via microprocessor data bus 212; the LAN DMA controllers 242 and 262 are programmed by loading control registers on the respective controllers via the microprocessor data bus 212, respective bidirectional buffers 230 and 250, and respective LAN data buses 232 and 252, and the parity FIFOs 240 and 260 are programmed as set forth in the Appendix.

If the destination workstation of the IP packet to be routed is on an Ethernet connected to a different one of the network controllers 110, then the packet is copied into the appropriate LAN memory on the NC 110 to which that Ethernet is connected. Such copying is accomplished by first copying the packet into system memory 116, in the manner described above with respect to certain ARP packets, and then notifying the destination NC that a packet is available. When an NC is so notified, it programs its own parity FIFO and DMA controllers to copy the packet from system memory 116 into the appropriate LAN memory. It is noteworthy that though this type of IP routing does create VME bus traffic, it still does not involve the host CPU 118.

If the IP packet received over the Ethernet 122a and now stored in LAN memory 236 is an NFS packet intended for the server 100, then the microprocessor 210 performs all necessary protocol preprocessing to extract the NFS message and convert it to the local NFS (LNFS) format. This may well involve the logical concatenation of data extracted from a large number of individual IP packets stored in LAN memory 236, resulting in a linked list, in CPU memory 214, pointing to the different blocks of data in LAN memory 236 in the correct sequence.

The exact details of the LNFS format are not important for an understanding of the invention, except to note that it includes commands to maintain a directory of files which are stored on the disks attached to the storage processors 114, commands for reading and writing data to and from a file on the disks, and various configuration management and diagnostics control messages. The directory maintenance commands which are supported by LNFS include the following messages based on conventional NFS: get attributes of a file (GETATTR); set attributes of a file (SETATTR); look up a file (LOOKUP); create a file (CREATE); remove a file (REMOVE); rename a file (RENAME); create a new linked file (LINK); create a symlink (SYMLINK); remove a directory (RMDIR); and return file system statistics (STATFS). The data transfer commands supported by LNFS include read from a file (READ); write to a file (WRITE); read from a directory (REaddir); and read a link (READLINK). LNFS also supports a buffer release command (RELEASE), for notifying the file controller that an NC is finished using a specified buffer in system memory. It also supports a VOP-derived access command, for determining whether a given type access is legal for specified credential on a specified file.

If the LNFS request includes the writing of file data from the LAN memory 236 to disk, the NC 110a first requests a buffer in system memory 116 to be allocated by the appropriate FC 112. When a pointer to the buffer is returned, microprocessor 210 programs LAN DMA controller 242, parity FIFO 240 and VME/FIFO DMA controller 272 to transmit the entire block of file data to system memory 116. The only difference between this transfer and the transfer described above for transmitting IP packets and ARP packets to system memory 116 is that these data blocks will typically have portions scattered throughout LAN memory 236. The microprocessor 210 accommodates that situation by programming LAN DMA controller 242 successively for each portion of the data, in accordance with the linked list, after receiving notification that the previous portion is complete. The microprocessor 210 can program the parity FIFO 240 and the VME/FIFO DMA controller 272 once for the entire message, as long as the entire data block is to be placed contiguously in system memory 116. If it is not, then the microprocessor 210 can program the DMA controller 272 for successive blocks in the same manner LAN DMA controller 242.

If the network controller 110a receives a message from another processor in server 100, usually from file controller 112, that file data is available in system memory 116 for transmission on one of the Ethernets, for example Ethernet

122a, then the network controller 110a copies the file data into LAN memory 236 in a manner similar to the copying of file data in the opposite direction. In particular, the microprocessor 210 first programs VME/FIFO DMA controller 272 with the starting address and length of the data in system memory 116, and programs the controller to begin transferring data over the VME bus 120 into port B of parity FIFO 240 as soon as the FIFO is ready to receive data. The microprocessor 210 then programs the LAN DMA controller 242 with a destination address in LAN memory 236 and then length of the file data, and instructs that controller to transfer data from the parity FIFO 240 into the LAN memory 236. Third, microprocessor 210 programs the parity FIFO 240 with the direction of the transfer to take place. The transfer then proceeds entirely under the control of DMA controllers 242 and 272, without any further involvement by the microprocessor 210. Again, if the file data is scattered in multiple blocks in system memory 116, the microprocessor 210 programs the VME/FIFO DMA controller 272 with a linked list of the blocks to transfer in the proper order.

When each of the DMA controllers 242 and 272 complete their work, they so notify microprocessor 210 through MFP 224. The microprocessor 210 then performs all necessary protocol processing on the LNFS message in LAN memory 236 in order to prepare the message for transmission over the Ethernet 122a in the form of Ethernet IP packets. As set forth above, this protocol processing is performed entirely in network controller 110a, without any involvement of the local host 118.

It should be noted that the parity FIFOs are designed to move multiples of 128-byte blocks most efficiently. The data transfer size through port B is always 32-bits wide, and the VME address corresponding to the 32-bit data must be quad-byte aligned. The data transfer size for port A can be either 8 or 16 bits. For bus utilization reasons, it is set to 16 bits when the corresponding local start address is double-byte aligned, and is set at 8 bits otherwise. The TCP/IP checksum is always computed in the 16 bit mode. Therefore, the checksum word requires byte swapping if the local start address is not double-byte aligned.

Accordingly, for transfer from port B to port A of any of the FIFOs 240, 260 or 270, the microprocessor 210 programs the VME/FIFO DMA controller to pad the transfer count to the next 128-byte boundary. The extra 32-bit word transfers do not involve the VME bus, and only the desired number of 32-bit words will be unloaded from port A.

For transfers from port A to port B of the parity FIFO 270, the microprocessor 210 loads port A word-by-word and forces a FIFO full indication when it is finished. The FIFO full indication enables unloading from port B. The same procedure also takes place for transfers from port A to port B of either of the parity FIFOs 240 or 260, since transfers of fewer than 128 bytes are performed under local microprocessor control rather than under the control of LAN DMA controller 242 or 262. For all of the FIFOs, the VME/FIFO DMA controller is programmed to unload only the desired number of 32-bit words.

FILE CONTROLLER HARDWARE ARCHITECTURE

The file controllers (FC) 112 may each be a standard off-the-shelf microprocessor board, such as one manufactured by Motorola Inc. Preferably, however, a more specialized board is used such as that shown in block diagram form in Fig. 4.

Fig. 4 shows one of the FCs 112a, and it will be understood that the other FC can be identical. In many aspects it is simply a scaled-down version of the NC 110a shown in Fig. 3, and in some respects it is scaled up. Like the NC 110a, FC 112a comprises a 20MHz 68020 microprocessor 310 connected to a 32-bit microprocessor data bus 312. Also connected to the microprocessor data bus 312 is a 256K byte shared CPU memory 314. The low order 8 bits of the microprocessor data bus 312 are connected through a bidirectional buffer 316 to an 8-bit slow-speed data bus 318. On slow-speed data bus 318 are a 128K byte PROM 320, and a multifunction peripheral (MFP) 324. The functions of the PROM 320 and MFP 324 are the same as those described above with respect to EPROM 220 and MFP 224 on NC 110a. FC 112a does not include PROM like the PROM 222 on NC 110a, but does include a parallel port 392. The parallel port 392 is mainly for testing and diagnostics.

Like the NC 110a, the FC 112a is connected to the VME bus 120 via a bidirectional buffer 380 and a 32-bit local data bus 376. A set of control registers 382 are connected to the local data bus 376, and directly addressable across the VME bus 120. The local data bus 376 is also coupled to the microprocessor data bus 312 via a bidirectional buffer 384. This permits the direct addressability of CPU memory 314 from VME bus 120.

FC 112a also includes a command FIFO 390, which includes an input port coupled to the local data bus 376 and which is directly addressable across the VME bus 120. The command FIFO 390 also includes an output port connected to the microprocessor data bus 312. The structure, operation and purpose of command FIFO 390 are the same as those described above with respect to command FIFO 290 on NC 110a.

The FC 112a omits the LAN data buses 323 and 352 which are present in NC 110a, but instead includes a 4 megabyte 32-bit wide FC memory 396 coupled to the microprocessor data bus 312 via a bidirectional buffer 394. As will be seen, FC memory 396 is used as a cache memory for file control information, separate from the file data information cached in system memory 116.

The file controller embodiment shown in Fig. 4 does not include any DMA controllers, and hence cannot act as a

master for transmitting or receiving data in any block transfer mode, over the VME bus 120. Block transfers do occur with the CPU memory 314 and the FC memory 396, however, with the FC 112a acting as an VME bus slave. In such transfers, the remote master addresses the CPU memory 314 or the FC memory 396 directly over the VME bus 120 through the bidirectional buffers 384 and, if appropriate, 394.

5 FILE CONTROLLER OPERATION

The purpose of the FC 112a is basically to provide virtual file system services in response to requests provided in LNFS format by remote processors on the VME bus 120. Most requests will come from a network controller 110, but requests may also come from the local host 118.

10 The file related commands supported by LNFS are identified above. They are all specified to the FC 112a in terms of logically identified disk data blocks. For example, the LNFS command for reading data from a file includes a specification of the file from which to read (file system ID (FSID) and file ID (inode)), a byte offset, and a count of the number of bytes to read. The FC 112a converts that identification into physical form, namely disk and sector numbers, in order to satisfy the command.

15 The FC 112a runs a conventional Fast File System (FFS or UFS), which is based on the Berkeley 4.3 VAX release. This code performs the conversion and also performs all disk data caching and control data caching. However, as previously mentioned, control data caching is performed using the FC memory 396 on FC 112a, whereas disk data caching is performed using the system memory 116 (Fig. 2). Caching this file control information within the FC 112a avoids the VME bus congestion and speed degradation which would result if file control information was cached in system memory 116. The memory on the FC 112a is directly accessed over the VME bus 120 for three main purposes. First, and by far the most frequent, are accesses to FC memory 396 by an SP 114 to read or write cached file control information. These are accesses requested by FC 112a to write locally modified file control structures through to disk, or to read file control structures from disk. Second, the FC's CPU memory 314 is accessed directly by other processors for message transmissions from the FC 112a to such other processors. For example, if a data block in system memory is to be transferred to an SP 114 for writing to disk, the FC 112a first assembles a message in its local memory 314 requesting such a transfer. The FC 112a then notifies the SP 114, which copies the message directly from the CPU memory 314 and executes the requested transfer.

20 A third type of direct access to the FC's local memory occurs when an LNFS client reads directory entries. When FC 112a receives an LNFS request to read directory entries, the FC 112a formats the requested directory entries in FC memory 396 and notifies the requestor of their location. The requestor then directly accesses FC memory 396 to read the entries.

The version of the UFS code on FC 112a includes some modifications in order to separate the two caches. In particular, two sets of buffer headers are maintained, one for the FC memory 396 and one for the system memory 116. Additionally, a second set of the system buffer routines (GETBLK(), BRELSE(), BREAD(), BWRITE(), and BREADA()) exist, one for buffer accesses to FC Mem 396 and one for buffer accesses to system memory 116. The UFS code is further modified to call the appropriate buffer routines for FC memory 396 for accesses to file control information, and to call the appropriate buffer routines for the system memory 116 for the caching of disk data. A description of UFS may be found in chapters 2, 6, 7 and 8 of "Kernel Structure and Flow," by Rieken and Webb of .sh consulting (Santa Clara, California: 1988).

40 When a read command is sent to the FC by a requestor such as a network controller, the FC first converts the file, offset and count information into disk and sector information. It then locks the system memory buffers which contain that information, instructing the storage processor 114 to read them from disk if necessary. When the buffer is ready, the FC returns a message to the requestor containing both the attributes of the designated file and an array of buffer descriptors that identify the locations in system memory 116 holding the data.

45 After the requestor has read the data out of the buffers, it sends a release request back to the FC. The release request is the same message that was returned by the FC in response to the read request; the FC 112a uses the information contained therein to determine which buffers to free.

50 A write command is processed by FC 112a similarly to the read command, but the caller is expected to write to (instead of read from) the locations in system memory 116 identified by the buffer descriptors returned by the FC 112a. Since FC 112a employs write-through caching, when it receives the release command from the requestor, it instructs storage processor 114 to copy the data from system memory 116 onto the appropriate disk sectors before freeing the system memory buffers for possible reallocation.

55 The READDIR transaction is similar to read and write, but the request is satisfied by the FC 112a directly out of its own FC memory 396 after formatting the requested directory information specifically for this purpose. The FC 112a causes the storage processor read the requested directory information from disk if it is not already locally cached. Also, the specified offset is a "magic cookie" instead of a byte offset, identifying directory entries instead of an absolute byte offset into the file. No file attributes are returned.

The READLINK transaction also returns no file attributes, and since links are always read in their entirety, it does not require any offset or count.

For all of the disk data caching performed through system memory 116, the FC 112a acts as a central authority for dynamically allocating, deallocating and keeping track of buffers. If there are two or more FCs 112, each has exclusive control over its own assigned portion of system memory 116. In all of these transactions, the requested buffers are locked during the period between the initial request and the release request. This prevents corruption of the data by other clients.

Also in the situation where there are two or more FCs, each file system on the disks is assigned to a particular one of the FCs. FC #0 runs a process called FC_VICE_PRESIDENT, which maintains a list of which file systems are assigned to which FC. When a client processor (for example an NC 110) is about to make an LNFS request designating a particular file system, it first sends the fsid in a message to the FC_VICE_PRESIDENT asking which FC controls the specified file system. The FC_VICE_PRESIDENT responds, and the client processor sends the LNFS request to the designated FC. The client processor also maintains its own list of fsid/FC pairs as it discovers them, so as to minimize the number of such requests to the FC_VICE_PRESIDENT.

STORAGE PROCESSOR HARDWARE ARCHITECTURE

In the file server 100, each of the storage processors 114 can interface the VME bus 120 with up to 10 different SCSI buses. Additionally, it can do so at the full usage rate of an enhanced block transfer protocol of 55MB per second.

Fig. 5 is a block diagram of one of the SPs 114a. SP 114b is identical. SP 114a comprises a microprocessor 510, which may be a Motorola 68020 microprocessor operating at 20MHz. The microprocessor 510 is coupled over a 32-bit microprocessor data bus 512 with CPU memory 514, which may include up to 1MB of static RAM. The microprocessor 510 accesses instructions, data and status on its own private bus 512, with no contention from any other source. The microprocessor 510 is the only master of bus 512.

The low order 16 bits of the microprocessor data bus 512 interface with a control bus 516 via a bidirectional buffer 518. The low order 8 bits of the control bus 516 interface with a slow speed bus 520 via another bidirectional buffer 522. The slow speed bus 520 connects to an MFP 524, similar to the MFP 224 in NC 110a (Fig. 3), and with a PROM 526, similar to PROM 220 on NC 110a. The PROM 526 comprises 128K bytes of EPROM which contains the functional code for SP 114a. Due to the width and speed of the EPROM 526, the functional code is copied to CPU memory 514 upon reset for faster execution.

MFP 524, like the MFP 224 on NC 110a, comprises a Motorola 68901 multifunction peripheral device. It provides the functions of a vectored interrupt controller, individually programmable I/O pins, four timers and a UART. The UART functions provide serial communications across an RS 232 bus (not shown in Fig. 5) for debug monitors and diagnostics. Two of the four timing functions may be used as general-purpose timers by the microprocessor 510, either independently or in cascaded fashion. A third timer function provides the refresh clock for a DMA controller described below, and the fourth timer generates the UART clock. Additional information on the MFP 524 can be found in "MC 68901 Multi-Function Peripheral Specification," by Motorola, Inc. The eight general-purpose I/O bits provided by MFP 524 are configured according to the following table:

Bit	Direction	Definition
7	input	Power Failure is Imminent - This functions as an early warning.
6	input	SCSI Attention - A composite of the SCSI. Attentions from all 10 SCSI channels.
5	input	Channel Operation Done - A composite of the channel done bits from all 13 channels of the DMA controller, described below.
4	output	DMA Controller Enable. Enables the DMA Controller to run.
3	input	VMEbus Interrupt Done - Indicates the completion of a VMEbus Interrupt.
2	input	Command Available - Indicates that the SP'S Command Fifo, described below, contains one or more command pointers.
1	output	External Interrupts Disable. Disables externally generated interrupts to the microprocessor 510.

(continued)

Bit	Direction	Definition
0	output	Command Fifo Enable. Enables operation of the SP'S Command Fifo. Clears the Command Fifo when reset.

Commands are provided to the SP 114a from the VME bus 120 via a bidirectional buffer 530, a local data bus 532, and a command FIFO 534. The command FIFO 534 is similar to the command FIFOs 290 and 390 on NC 110a and FC 112a, respectively, and has a depth of 256 32-bit entries. The command FIFO 534 is a write-only register as seen on the VME bus 120, and as a read-only register as seen by microprocessor 510. If the FIFO is full at the beginning of a write from the VME bus, a VME bus error is generated. Pointers are removed from the command FIFO 534 in the order received, and only by the microprocessor 510. Command available status is provided through IO bit 4 of the MFP 524, and as long as one or more command pointers are still within the command FIFO 534, the command available status remains asserted.

As previously mentioned, the SP 114a supports up to 10 SCSI buses or channels 540a-540j. In the typical configuration, buses 540a-540i support up to 3 SCSI disk drives each, and channel 540j supports other SCSI peripherals such as tape drives, optical disks, and so on. Physically, the SP 114a connects to each of the SCSI buses with an ultra-miniature D sub connector and round shielded cables. Six 50-pin cables provide 300 conductors which carry 18 signals per bus and 12 grounds. The cables attach at the front panel of the SP 114a and to a commutator board at the disk drive array. Standard 50-pin cables connect each SCSI device to the commutator board. Termination resistors are installed on the SP 114a.

The SP 114a supports synchronous parallel data transfers up to 5MB per second on each of the SCSI buses 540, arbitration, and disconnect/reconnect services. Each SCSI bus 540 is connected to a respective SCSI adaptor 542, which in the present embodiment is an AIC 6250 controller IC manufactured by Adaptec Inc., Milpitas, California, operating in the non-multiplexed address bus mode. The AIC 6250 is described in detail in "AIC-6250 Functional Specification," by Adaptec Inc. The SCSI adaptors 542 each provide the necessary hardware interface and low-level electrical protocol to implement its respective SCSI channel.

The 8-bit data port of each of the SCSI adaptors 542 is connected to port A of a respective one of a set of ten parity FIFOs 544a-544j. The FIFOs 544 are the same as FIFOs 240, 260 and 270 on NC 110a, and are connected and configured to provide parity covered data transfers between the 8-bit data port of the respective SCSI adaptors 542 and a 36-bit (32-bit plus 4 bits of parity) common data bus 550. The FIFOs 544 provide handshake, status, word assembly/disassembly and speed matching FIFO buffering for this purpose. The FIFOs 544 also generate and check parity for the 32-bit bus, and for RAID 5 implementations they accumulate and check redundant data and accumulate recovered data.

All of the SCSI adaptors 542 reside at a single location of the address space of the microprocessor 510, as do all of the parity FIFOs 544. The microprocessor 510 selects individual controllers and FIFOs for access in pairs, by first programming a pair select register (not shown) to point to the desired pair and then reading from or writing to the control register address of the desired chip in the pair. The microprocessor 510 communicates with the control registers on the SCSI adaptors 542 via the control bus 516 and an additional bidirectional buffer 546, and communicates with the control registers on FIFOs 544 via the control bus 516 and a bidirectional buffer 552. Both the SCSI adaptors 542 and FIFOs 544 employ 8-bit control registers, and register addressing of the FIFOs 544 is arranged such that such registers alias in consecutive byte locations. This allows the microprocessor 510 to write to the registers as a single 32-bit register, thereby reducing instruction overhead.

The parity FIFOs 544 are each configured in their Adaptec 6250 mode. Referring to the Appendix, the FIFOs 544 are programmed with the following bit settings in the Data Transfer Configuration Register:

Bit	Definition	Setting
0	WD Mode	(0)
1	Parity Chip	(1)
2	Parity Correct Mode	(0)
3	8/16 bits CPU & PortA interface	(0)
4	Invert Port A address 0	(1)
5	Invert Port A address 1	(1)
6	Checksum Carry Wrap	(0)
7	Reset	(0)

EP 0 490 973 B1

The Data Transfer Control Register is programmed as follows:

5

Bit	Definition	Setting
0	Enable PortA Req/Ack	(1)
1	Enable PortB Req/Ack	(1)
2	Data Transfer Direction	as desired
3	CPU parity enable	(0)
4	PortA parity enable	(1)
5	PortB parity enable	(1)
6	Checksum Enable	(0)
7	PortA Master	(0)

10

15

In addition, bit 4 of the RAM Access Control Register (Long Burst) is programmed for 8-byte bursts.

SCSI adaptors 542 each generate a respective interrupt signal, the status of which are provided to microprocessor 510 as 10 bits of a 16-bit SCSI interrupt register 556. The SCSI interrupt register 556 is connected to the control bus 516. Additionally, a composite SCSI interrupt is provided through the MFP 524 whenever any one of the SCSI adaptors 542 needs servicing.

20

An additional parity FIFO 554 is also provided in the SP 114a, for message passing. Again referring to the Appendix, the parity FIFO 554 is programmed with the following bit settings in the Data Transfer Configuration Register.

25

Bit	Definition	Setting
0	WD Mode	(0)
1	Parity Chip	(1)
2	Parity Correct Mode	(0)
3	8/16 bits CPU & PortA interface	(1)
4	Invert Port A address 0	(1)
5	Invert Port A address 1	(1)
6	Checksum Carry Wrap	(0)
7	Reset	(0)

30

The Data Transfer Control Register is programmed as follows:

35

Bit	Definition	Setting
0	Enable PortA Req/Ack	(0)
1	Enable PortB Req/Ack	(1)
2	Data Transfer Direction	as desired
3	CPU parity enable	(0)
4	PortA parity enable	(0)
5	PortB parity enable	(1)
6	Checksum Enable	(0)
7	PortA Master	(0)

40

45

In addition, bit 4 of the RAM Access Control Register (Long Burst) is programmed for 8-byte bursts.

Port A of FIFO 554 is connected to the 16-bit control bus 516, and port B is connected to the common data bus 550. FIFO 554 provides one means by which the microprocessor 510 can communicate directly with the VME bus 120, as is described in more detail below.

50

The microprocessor 510 manages data movement using a set of 15 channels, each of which has an unique status which indicates its current state. Channels are implemented using a channel enable register 560 and a channel status register 562, both connected to the control bus 516. The channel enable register 560 is a 16-bit write-only register, whereas the channel status register 562 is a 16-bit read-only register. The two registers reside at the same address to microprocessor 510. The microprocessor 510 enables a particular channel by setting its respective bit in channel enable register 560, and recognizes completion of the specified operation by testing for a "done" bit in the channel status register 562. The microprocessor 510 then resets the enable bit, which causes the respective "done" bit in the

55

EP 0 490 973 B1

channel status register 562 to be cleared.
The channels are defined as follows:

CHANNEL	FUNCTION
0:9	These channels control data movement to and from the respective FIFOs 544 via the common data bus 550. When a FIFO is enabled and a request is received from it, the channel becomes ready. Once the channel has been serviced a status of done is generated.
11:10	These channels control data movement between a local data buffer 564, described below, and the VME bus 120. When enabled the channel becomes ready. Once the channel has been serviced a status of done is generated.
12	When enabled, this channel causes the DRAM in local data buffer 564 to be refreshed based on a clock which is generated by the MFP 524. The refresh consists of a burst of 16 rows. This channel does not generate a status of done.
13	The microprocessor's communication FIFO 554 is serviced by this channel. When enable is set and the FIFO 554 asserts a request then the channel becomes ready. This channel generates a status of done.
14	Low latency writes from microprocessor 510 onto the VME bus 120 are controlled by this channel. When this channel is enabled data is moved from a special 32 bit register, described below, onto the VME bus 120. This channel generates a done status.
15	This is a null channel for which neither a ready status nor done status is generated.

Channels are prioritized to allow servicing of the more critical requests first. Channel priority is assigned in a descending order starting at channel 14. That is, in the event that all channels are requesting service, channel 14 will be the first one served.

The common data bus 550 is coupled via a bidirectional register 570 to a 36-bit junction bus 572. A second bidirectional register 574 connects the junction bus 572 with the local data bus 532. Local data buffer 564, which comprises 1MB of DRAM, with parity, is coupled bidirectionally to the junction bus 572. It is organized to provide 256K 32-bit words with byte parity. The SP 114a operates the DRAMs in page mode to support a very high data rate, which requires bursting of data instead of random single-word accesses. It will be seen that the local data buffer 564 is used to implement a RAID (redundant array of inexpensive disks) algorithm, and is not used for direct reading and writing between the VME bus 120 and a peripheral on one of the SCSI buses 540.

A read-only register 576, containing all zeros, is also connected to the junction bus 572. This register is used mostly for diagnostics, initialization, and clearing of large blocks of data in system memory 116.

The movement of data between the FIFOs 544 and 554, the local data buffer 564, and a remote entity such as the system memory 116 on the VME bus 120, is all controlled by a VME/FIFO DMA controller 580. The VME/FIFO DMA controller 580 is similar to the VME/FIFO DMA controller 272 on network controller 110a (Fig. 3), and is described in the Appendix. Briefly, it includes a bit slice engine 582 and a dual-port static RAM 584. One port of the dual-port static RAM 584 communicates over the 32-bit microprocessor data bus 512 with microprocessor 510, and the other port communicates over a separate 16-bit bus with the bit slice engine 582. The microprocessor 510 places command parameters in the dual-port RAM 584, and uses the channel enables 560 to signal the VME/FIFO DMA controller 580 to proceed with the command. The VME/FIFO DMA controller is responsible for scanning the channel status and servicing requests, and returning ending status in the dual-port RAM 584. The dual-port RAM 584 is organized as 1K x 32 bits at the 32-bit port and as 2K x 16 bits at the 16-bit port. An example showing the method by which the microprocessor 510 controls the VME/FIFO DMA controller 580 is as follows. First, the microprocessor 510 writes into the dual-port RAM 584 the desired command and associated parameters for the desired channel. For example, the command might be, "copy a block of data from FIFO 544h out into a block of system memory 116 beginning at a specified VME address." Second, the microprocessor sets the channel enable bit in channel enable register 560 for the desired channel.

At the time the channel enable bit is set, the appropriate FIFO may not yet be ready to send data. Only when the VME/FIFO DMA controller 580 does receive a "ready" status from the channel, will the controller 580 execute the command. In the meantime, the DMA controller 580 is free to execute commands and move data to or from other channels.

When the DMA controller 580 does receive a status of "ready" from the specified channel, the controller fetches the channel command and parameters from the dual-ported RAM 584 and executes. When the command is complete, for example all the requested data has been copied, the DMA controller writes status back into the dual-port RAM 584 and asserts "done" for the channel in channel status register 562. The microprocessor 510 is then interrupted, at which time it reads channel status register 562 to determine which channel interrupted. The microprocessor 510 then clears the channel enable for the appropriate channel and checks the ending channel status in the dual-port RAM 584.

In this way a high-speed data transfer can take place under the control of DMA controller 580, fully in parallel with other activities being performed by microprocessor 510. The data transfer takes place over busses different from microprocessor data bus 512, thereby avoiding any interference with microprocessor instruction fetches.

The SP 114a also includes a high-speed register 590, which is coupled between the microprocessor data bus 512 and the local data bus 532. The high-speed register 590 is used to write a single 32-bit word to an VME bus target with a minimum of overhead. The register is write only as viewed from the microprocessor 510. In order to write a word onto the VME bus 120, the microprocessor 510 first writes the word into the register 590, and the desired VME target address into dual-port RAM 584. When the microprocessor 510 enables the appropriate channel in channel enable register 560, the DMA controller 580 transfers the data from the register 590 into the VME bus address specified in the dual-port RAM 584. The DMA controller 580 then writes the ending status to the dual-port RAM and sets the channel "done" bit in channel status register 562.

This procedure is very efficient for transfer of a single word of data, but becomes inefficient for large blocks of data. Transfers of greater than one word of data, typically for message passing, are usually performed using the FIFO 554.

The SP 114a also includes a series of registers 592, similar to the registers 282 on NC 110a (Fig. 3) and the registers 382 on FC 112a (Fig. 4). The details of these registers are not important for an understanding of the present invention.

STORAGE PROCESSOR OPERATION

The 30 SCSI disk drives supported by each of the SPs 114 are visible to a client processor, for example one of the file controllers 112, either as three large, logical disks or as 30 independent SCSI drives, depending on configuration. When the drives are visible as three logical disks, the SP uses RAID 5 design algorithms to distribute data for each logical drive on nine physical drives to minimize disk arm contention. The tenth drive is left as a spare. The RAID 5 algorithm (redundant array of inexpensive drives, revision 5) is described in "A Case For a Redundant Arrays of Inexpensive Disks (RAID)", by Patterson et al., published at ACM SIGMOD Conference, Chicago, Ill., June 1-3, 1988.

In the RAID 5 design, disk data are divided into stripes. Data stripes are recorded sequentially on eight different disk drives. A ninth parity stripe, the exclusive-or of eight data stripes, is recorded on a ninth drive. If a stripe size is set to 8K bytes, a read of 8K of data involves only one drive. A write of 8K of data involves two drives: a data drive and a parity drive. Since a write requires the reading back of old data to generate a new parity stripe, writes are also referred to as modify writes. The SP 114a supports nine small reads to nine SCSI drives concurrently. When stripe size is set to 8K, a read of 64K of data starts all eight SCSI drives, with each drive reading one 8K stripe worth of data. The parallel operation is transparent to the caller client.

The parity stripes are rotated among the nine drives in order to avoid drive contention during write operations. The parity stripe is used to improve availability of data. When one drive is down, the SP 114a can reconstruct the missing data from a parity stripe. In such case, the SP 114a is running in error recovery mode. When a bad drive is repaired, the SP 114a can be instructed to restore data on the repaired drive while the system is on-line.

When the SP 114a is used to attach thirty independent SCSI drives, no parity stripe is created and the client addresses each drive directly.

The SP 114a processes multiple messages (transactions, commands) at one time, up to 200 messages per second. The SP 114a does not initiate any messages after initial system configuration. The following SP 114a operations are defined:

01	No Op
02	Send Configuration Data
03	Receive Configuration Data
05	Read and Write Sectors
06	Read and Write Cache Pages
07	IOCTL Operation
08	Dump SP 114a Local Data Buffer
09	Start/Stop A SCSI Drive

EP 0 490 973 B1

(continued)

0C	Inquiry
0E	Read Message Log Buffer
0F	Set SP 114a Interrupt

5

The above transactions are described in detail in the above-identified application entitled MULTIPLE FACILITY OPERATING SYSTEM ARCHITECTURE. For the understanding of the invention, it will be useful to describe the function and operation of only two of these commands: read and write sectors, and read and write cache pages.

10

Read and Write Sectors

This command, issued usually by an FC 112, causes the SP 114a to transfer data between a specified block of system memory and a specified series of contiguous sectors on the SCSI disks. As previously described in connection with the file controller 112, the particular sectors are identified in physical terms. In particular, the particular disk sectors are identified by SCSI channel number (0-9), SCSI ID on that channel number (0-2), starting sector address on the specified drive, and a count of the number of sectors to read or write. The SCSI channel number is zero if the SP 114a is operating under RAID 5.

15

The SP 114a can execute up to 30 messages on the 30 SCSI drives simultaneously. Unlike most of the commands to an SP 114, which are processed by microprocessor 510 as soon as they appear on the command FIFO 534, read and write sectors commands (as well as read and write cache memory commands) are first sorted and queued. Hence, they are not served in the order of arrival.

20

When a disk access command arrives, the microprocessor 510 determines which disk drive is targeted and inserts the message in a queue for that disk drive sorted by the target sector address. The microprocessor 510 executes commands on all the queues simultaneously, in the order present in the queue for each disk drive. In order to minimize disk arm movements, the microprocessor 510 moves back and forth among queue entries in an elevator fashion.

25

If no error conditions are detected from the SCSI disk drives, the command is completed normally. When a data check error condition occurs and the SP 114a is configured for RAID 5, recovery actions using redundant data begin automatically. When a drive is down while the SP 114a is configured for RAID 5, recovery actions similar to data check recovery take place.

30

Read/Write Cache Pages

This command is similar to read and write sectors, except that multiple VME addresses are provided for transferring disk data to and from system memory 116. Each VME address points to a cache page in system memory 116, the size of which is also specified in the command. When transferring data from a disk to system memory 116, data are scattered to different cache pages; when writing data to a disk, data are gathered from different cache pages in system memory 116. Hence, this operation is referred to as a scatter-gather function.

35

The target sectors on the SCSI disks are specified in the command in physical terms, in the same manner that they are specified for the read and write sectors command. Termination of the command with or without error conditions is the same as for the read and write sectors command.

40

The dual-port RAM 584 in the DMA controller 580 maintains a separate set of commands for each channel controlled by the bit slice engine 582. As each channel completes its previous operation, the microprocessor 510 writes a new DMA operation into the dual-port RAM 584 for that channel in order to satisfy the next operation on a disk elevator queue.

45

The commands written to the DMA controller 580 include an operation code and a code indicating whether the operation is to be performed in non-block mode, in standard VME block mode, or in enhanced block mode. The operation codes supported by DMA controller 580 are as follows:

50

OP CODE	OPERATION	
0	NO-OP	
1	ZEROES → BUFFER	Move zeros from zeros register 576 to local data buffer 564.
2	ZEROES → FIFO	Move zeros from zeros register 576 to the currently selected FIFO on common data bus 550.

55

(continued)

OP CODE	OPERATION	
5 3	ZEROES → VMEbus	Move zeros from zeros register 576 out onto the VME bus 120. Used for initializing cache buffers in system memory 116.
10 4	VMEbus → BUFFER	Move data from the VME bus 120 to the local data buffer 564. This operation is used during a write, to move target data intended for a down drive into the buffer for participation in redundancy generation. Used only for RAID 5 application.
15 5	VMEbus → FIFO	New data to be written from VME bus onto a drive. Since RAID 5 requires redundancy data to be generated from data that is buffered in local data buffer 564, this operation will be used only if the SP 114a is not configured for RAID 5.
20 6	VMEbus → BUFFER & FIFO	Target data is moved from VME bus 120 to a SCSI device and is also captured in the local data buffer 564 for participation in redundancy generation. Used only if SP 114a is configured for RAID 5 operation.
25 7	BUFFER → VMEbus	This operation is not used.
8	BUFFER → FIFO	Participating data is transferred to create redundant data or recovered data on a disk drive. Used only in RAID 5 applications.
30 9	FIFO → VMEbus	This operation is used to move target data directly from a disk drive onto the VME bus 120.
A	FIFO → BUFFER	Used to move participating data for recovery and modify operations. Used only in RAID 5 applications.
35 B	FIFO → VMEbus & BUFFER	This operation is used to save target data for participation in data recovery. Used only in RAID 5 applications.

SYSTEM MEMORY

40 Fig. 6 provides a simplified block diagram of the preferred architecture of one of the system memory cards 116a. Each of the other system memory cards are the same. Each memory card 116 operates as a slave on the enhanced VME bus 120 and therefore requires no on-board CPU. Rather, a timing control block 610 is sufficient to provide the necessary slave control operations. In particular, the timing control block 610, in response to control signals from the control portion of the enhanced VME bus 120, enables a 32-bit wide buffer 612 for an appropriate direction transfer of
45 32-bit data between the enhanced VME bus 120 and a multiplexer unit 614. The multiplexer 614 provides a multiplexing and demultiplexing function, depending on data transfer direction, for a six megabit by seventy-two bit word memory array 620. An error correction code (ECC) generation and testing unit 622 is also connected to the multiplexer 614 to generate or verify, again depending on transfer direction, eight bits of ECC data. The status of ECC verification is provided back to the timing control block 610.
50

ENHANCED VME BUS PROTOCOL

VME bus 120 is physically the same as an ordinary VME bus, but each of the NCs and SPs include additional circuitry and firmware for transmitting data using an enhanced VME block transfer protocol. The enhanced protocol is
55 described in detail in the above-identified application entitled ENHANCED VMEBUS PROTOCOL UTILIZING PSEUDOSYNCHRONOUS HANDSHAKING AND BLOCK MODE DATA TRANSFER, and summarized in the Appendix hereto. Typically transfers of LNFS file data between NCs and system memory, or between SPs and system memory, and

transfers of packets being routed from one NC to another through system memory, are the only types of transfers that use the enhanced protocol in server 100. All other data transfers on VME bus 120 use either conventional VME block transfer protocols or ordinary non-block transfer protocols.

5 MESSAGE PASSING

As is evident from the above description, the different processors in the server 100 communicate with each other via certain types of messages. In software, these messages are all handled by the messaging kernel, described in detail in the MULTIPLE FACILITY OPERATING SYSTEM ARCHITECTURE application cited above. In hardware, they are implemented as follows.

Each of the NCs 110, each of the FCs 112, and each of the SPs 114 includes a command or communication FIFO such as 290 on NC 110a. The host 118 also includes a command FIFO, but since the host is an unmodified purchased processor board, the FIFO is emulated in software. The write port of the command FIFO in each of the processors is directly addressable from any of the other processors over VME bus 120.

Similarly, each of the processors except SPs 114 also includes shared memory such as CPU memory 214 on NC 110a. This shared memory is also directly addressable by any of the other processors in the server 100.

If one processor, for example network controller 110a, is to send a message or command to a second processor, for example file controller 112a, then it does so as follows. First, it forms the message in its own shared memory (e.g., in CPU memory 214 on NC 110a). Second, the microprocessor in the sending processor directly writes a message descriptor into the command FIFO in the receiving processor. For a command being sent from network controller 110a to file controller 112a, the microprocessor 210 would perform the write via buffer 284 on NC 110a, VME bus 120, and buffer 384 on file controller 112a.

The command descriptor is a single 32-bit word containing in its high order 30 bits a VME address indicating the start of a quad-aligned message in the sender's shared memory. The low order two bits indicate the message type as follows:

Type	Description
0	Pointer to a new message being sent
1	Pointer to a reply message
2	Pointer to message to be forwarded
3	Pointer to message to be freed; also message acknowledgment

All messages are 128-bytes long.

When the receiving processor reaches the command descriptor on its command FIFO, it directly accesses the sender's shared memory and copies it into the receiver's own local memory. For a command issued from network controller 110a to file controller 112a, this would be an ordinary VME block or non-block mode transfer from NC CPU memory 214, via buffer 284, VME bus 120 and buffer 384, into FC CPU memory 314. The FC microprocessor 310 directly accesses NC CPU memory 214 for this purpose over the VME bus 120.

When the receiving processor has received the command and has completed its work, it sends a reply message back to the sending processor. The reply message may be no more than the original command message unaltered, or it may be a modified version of that message or a completely new message. If the reply message is not identical to the original command message, then the receiving processor directly accesses the original sender's shared memory to modify the original command message or overwrite it completely. For replies from the FC 112a to the NC 110a, this involves an ordinary VME block or non-block mode transfer from the FC 112a, via buffer 384, VME bus 120, buffer 284 and into NC CPU memory 214. Again, the FC microprocessor 310 directly accesses NC CPU memory 214 for this purpose over the VME bus 120.

Whether or not the original command message has been changed, the receiving processor then writes a reply message descriptor directly into the original sender's command FIFO. The reply message descriptor contains the same VME address as the original command message descriptor, and the low order two bits of the word are modified to indicate that this is a reply message. For replies from the FC 112a to the NC 110a, the message descriptor write is accomplished by microprocessor 310 directly accessing command FIFO 290 via buffer 384, VME bus 120 and buffer 280 on the NC. Once this is done, the receiving processor can free the buffer in its local memory containing the copy of the command message.

EP 0 490 973 B1

When the original sending processor reaches the reply message descriptor on its command FIFO, it wakes up the process that originally sent the message and permits it to continue. After examining the reply message, the original sending processor can free the original command message buffer in its own local shared memory.

As mentioned above, network controller 110a uses the buffer 284 data path in order to write message descriptors onto the VME bus 120, and uses VME/FIFO DMA controller 272 together with parity FIFO 270 in order to copy messages from the VME bus 120 into CPU memory 214. Other processors read from CPU memory 214 using the buffer 284 data path.

File controller 112a writes message descriptors onto the VME bus 120 using the buffer 384 data path, and copies messages from other processors' shared memory via the same data path. Both take place under the control of microprocessor 310. Other processors copy messages from CPU memory 314 also via the buffer 384 data path.

Storage processor 114a writes message descriptors onto the VME bus using high-speed register 590 in the manner described above, and copies messages from other processors using DMA controller 580 and FIFO 554. The SP 114a has no shared memory, however, so it uses a buffer in system memory 116 to emulate that function. That is, before it writes a message descriptor into another processor's command FIFO, the SP 114a first copies the message into its own previously allocated buffer in system memory 116 using DMA controller 580 and FIFO 554. The VME address included in the message descriptor then reflects the VME address of the message in system memory 116.

In the host 118, the command FIFO and shared memory are both emulated in software.

APPENDIX A

VME/FIFO DMA Controller

In storage processor 114a, DMA controller 580 manages the data path under the direction of the microprocessor 510. The DMA controller 580 is a microcoded 16-bit bit-slice implementation executing pipelined instructions at a rate of one each 62.5ns. It is responsible for scanning the channel status 562 and servicing request with parameters stored in the dual-ported ram 584 by the microprocessor 510. Ending status is returned in the ram 584 and interrupts are generated for the microprocessor 510.

Control Store. The control store contains the microcoded instructions which control the DMA controller 580. The control store consists of 6 1K x 8 proms configured to yield a 1K x 48 bit microword. Locations within the control store are addressed by the sequencer and data is presented at the input of the pipeline registers.

Sequencer. The sequencer controls program flow by generating control store addresses based upon pipeline data and various status bits. The control store address consists of 10 bits. Bits 8:0 of the control store address derive from a multiplexer having as its inputs either an ALU output or the output of an incrementer. The incrementer can be preloaded with pipeline register bits 8:0, or it can be incremented as a result of a test condition. The 1K address range is divided into two pages by a latched flag such that the microprogram can execute from either page. Branches, however remain within the selected page. Conditional sequencing is performed by having the test condition increment the pipeline provided address. A false condition allows execution from the pipeline address while a true condition causes execution from the address + 1. The alu output is selected as an address source in order to directly vector to a routine or in order to return to a calling routine. Note that when calling a subroutine the calling routine must reside within the same page as the subroutine or the wrong page will be selected on the return.

ALU. The alu comprises a single IDT49C402A integrated circuit. It is 16 bits in width and most closely resembles four 2901s with 64 registers. The alu is used primarily for incrementing, decrementing, addition and bit manipulation. All necessary control signals originate in the control store. The IDT HIGH PERFORMANCE CMOS 1988 DATA BOOK, incorporated by reference herein, contains additional information about the alu.

Microword. The 48 bit microword comprises several fields which control various functions of the DMA controller 580. The format of the microword is defined below along with mnemonics and a description of each function.

AI<8:0> 47:39	(Alu Instruction bits 8:0) The AI bits provide the instruction for the 49C402A alu. Refer to the IDT data book for a complete definition of the alu instructions. Note that the I9 signal input of the 49C402A is always low.
CIN 38	(Carry INput) This bit forces the carry input to the alu.
RA<5:0> 37:32	(Register A address bits 5:0) These bits select one of 64 registers as the "A" operand for the alu. These bits also provide literal bits 15:10 for the alu bus.
RB<5:0> 31:26	(Register B address bits 5:0) These bits select one of 64 registers as the "B" operand for the alu. These bits also provide literal bits 9:4 for the alu bus.

EP 0 490 973 B1

LFD 25 (Latched Flag Data) When set this bit causes the selected latched flag to be set. When reset this bit causes the selected latched flag to be cleared. This bits also functions as literal bit 3 for the alu bus.

5 LFS<2:0> 24:22 (Latched Flag Select bits 2:0) The meaning of these bits is dependent upon the selected source for the alu bus. In the event that the literal field is selected as the bus source then LFS<2:0> function as literal bits <2:0> otherwise the bits are used to select one of the latched flags.

LFS<2:0>	SELECTED FLAG
0	This value selects a null flag.
1	When set this bit enables the buffer clock. When reset this bit disables the buffer clock.
2	When this bit is cleared VME bus transfers, buffer operations and RAS are all disabled.
3	NOT USED
4	When set this bit enables VME bus transfers.
5	When set this bit enables buffer operations.
6	When set this bit asserts the row address strobe to the dram buffer.
7	When set this bit selects page 0 of the control store.

SRC<1,0> 20,21 (alu bus SouRCe select bits 1,0) These bits select the data source to be enabled onto the alu bus.

SRC<1,0>	Selected Source
0	alu
1	dual ported ram
2	literal
3	reserved-not defined

PF<2:0> 19:17 (Pulsed Flag select bits 2:0) These bits select a flag/signal to be pulsed.

PF<2:0>	Flag
0	null
1	SGL_CLK generates a single transition of buffer clock.
2	SET_VB forces vme and buffer enable to be set.
3	CL_PERR clears buffer parity error status.
4	SET_DN set channel done status for the currently selected channel.
5	INC_ADR increment dual ported ram address.

EP 0 490 973 B1

(continued)

PF<2:0>	Flag
6:7	RESERVED - NOT DEFINED

5

DEST<3:0> 16:13 (DESTination select bits 3:0) These bits select one of 10 destinations to be loaded from the alu bus.

DEST<3:0>	Destination
0	null
1	WR_RAM causes the data on the alu bus to be written to the dual ported ram. D<15:0> → ram<15:0>
2	WR_BADD loads the data from the alu bus into the dram address counters. D<14:7> → mux addr<8:0>
3	WR_VADL loads the data from the alu bus into the least significant 2 bytes of the VME address register. D<15:2> → VME addr<15:2> D1 → ENB_tional registers D<15:2> → VME addr<15:2> D1 → ENB_ENH D0 → ENB_BLK
4	WR_VADH loads the most significant 2 bytes of the VME address register. D<15:0> → VME addr<31:16>
5	WR_RADD loads the dual ported ram address counters. D<10:0> → ram addr <10:0>
6	WR_WCNT loads the word counters. D15 → count enable* D<14:8> → count <6:0>
7	WR_CO loads the co-channel select register. D<7:4> → CO<3:0>
8	WR_NXT loads the next-channel select register. D<3:0> → NEXT<3:0>
9	WR_CUR loads the current-channel select register. D<3:0> → CURR <3:0>
10:14	RESERVED - NOT DEFINED

10

15

20

25

30

35

40

45

50

55

EP 0 490 973 B1

(continued)

	DEST<3:0>	Destination
5	15	JUMP causes the control store sequencer to select the alu data bus. D<8:0> → CS_A<8:0>

10 TEST<3:0> 12:9 (TEST condition select bits 3:0) Select one of 16 inputs to the test multiplexor to be used as the carry input to the incrementer.

	TEST<3:0>	Condition	
	0	FALSE	-always false
15	1	TRUE	-always true
	2	ALU_COUT	-carry output of alu
	3	ALU_EQ	-equals output of alu
20	4	ALU_OVR	-alu overflow
	5	ALU_NEG	-alu negative
25	6	XFR_DONE	-transfer complete
	7	PAR_ERR	-buffer parity error
	8	TIMOUT	-bus operation timeout
30	9	ANY_ERR	-any error status
	14:10	RESERVED	-NOT DEFINED
35	15	CH_RDY	-next channel ready

NEXT_A<8:0> 8:0 (NEXT Address bits 8:0) Selects an instructions from the current page of the control store for execution.

40 Dual Ported Ram. The dual ported ram is the medium by which command, parameters and status are communicated between the DMA controller 580 and the microprocessor 510. The ram is organized as 1K x 32 at the master port and as 2K x 16 at the DMA port. The ram may be both written and read at either port.

The ram is addressed by the DMA controller 580 by loading an 11 bit address into the address counters. Data is then read into bidirectional registers and the address counter is incremented to allow read of the next location.

45 Writing the ram is accomplished by loading data from the processor into the registers after loading the ram address. Successive writes may be performed on every other processor cycle.

The ram contains current block pointers, ending status, high speed bus address and parameter blocks. The following is the format of the ram:

50

55

EP 0 490 973 B1

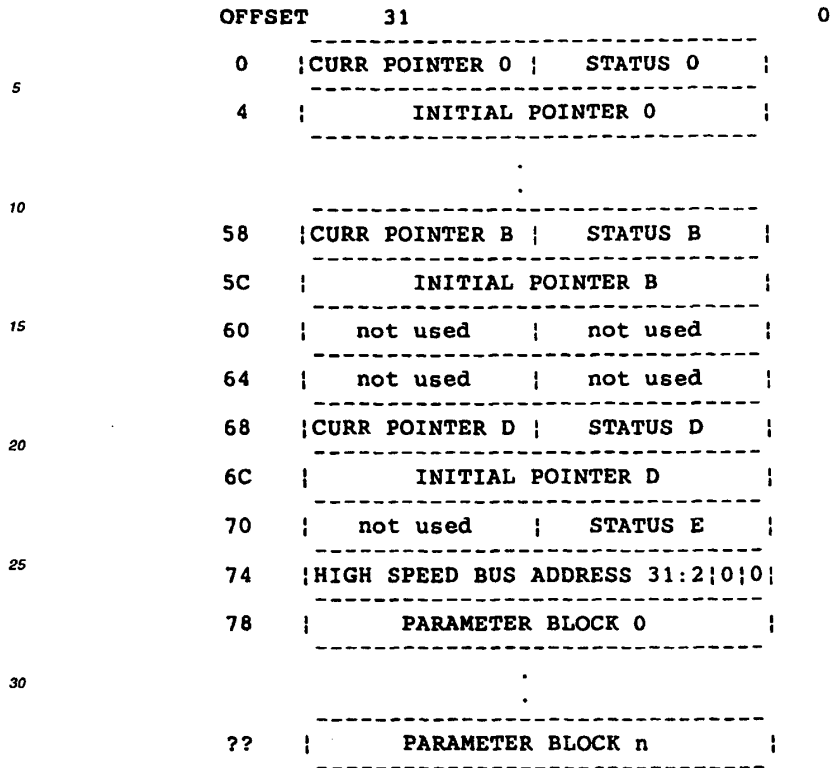

35 The Initial Pointer is a 32 bit value which points the first command block of a chain. The current pointer is a sixteen bit value used by the DMA controller 580 to point to the current command block. The current command block pointer should be initialized to 0x0000 by the microprocessor 510 before enabling the channel. Upon detecting a value of 0x0000 in the current block pointer the DMA controller 580 will copy the lower 16 bits from the initial pointer to the current pointer. Once the DMA controller 580 has completed the specified operations for the parameter block the current pointer will be updated to point to the next block. In the event that no further parameter blocks are available the pointer will be set to 0x0000.

40 The status byte indicates the ending status for the last channel operation performed. The following status bytes are defined:

STATUS	MEANING
0	NO ERRORS
1	ILLEGAL OP CODE
2	BUS OPERATION TIMEOUT
3	BUS OPERATION ERROR
4	DATA PATH PARITY ERROR

55 The format of the parameter block is:

5
10
15
20

OP CODE	OPERATION
0	NO-OP
1	ZEROES → BUFFER
2	ZEROES → FIFO
3	ZEROES → VMEbus
4	VMEbus → BUFFER
5	VMEbus → FIFO
6	VMEbus → BUFFER & FIFO
7	BUFFER → VMEbus
8	BUFFER → FIFO
9	FIFO → VMEbus
A	FIFO → BUFFER
B	FIFO → VMEbus & BUFFER
C	RESERVED
D	RESERVED
E	RESERVED
F	RESERVED

APPENDIX B

25

Enhanced VME Block Transfer Protocol

30
35
40
45
50
55

The enhanced VME block transfer protocol is a VMEbus compatible pseudo-synchronous fast transfer handshake protocol for use on a VME backplane bus having a master functional module and a slave functional module logically interconnected by a data transfer bus. The data transfer bus includes a data strobe signal line and a data transfer acknowledge signal line. To accomplish the handshake, the master transmits a data strobe signal of a given duration on the data strobe line. The master then awaits the reception of a data transfer acknowledge signal from the slave module on the data transfer acknowledge signal line. The slave then responds by transmitting data transfer acknowledge signal of a given duration on the data transfer acknowledge signal line.

Consistent with the pseudo-synchronous nature of the handshake protocol, the data to be transferred is referenced to only one signal depending upon whether the transfer operation is a READ or WRITE operation.

In transferring data from the master functional unit to the slave, the master broadcasts the data to be transferred. The master asserts a data strobe signal and the slave, in response to the data strobe signal, captures the data broadcast by the master. Similarly, in transferring data from the slave to the master, the slave broadcasts the data to be transferred to the master unit. The slave then asserts a data transfer acknowledge signal and the master, in response to the data transfer acknowledge signal, captures the data broadcast by the slave.

The fast transfer protocol, while not essential to the present invention, facilitates the rapid transfer of large amounts of data across a VME backplane bus by substantially increasing the data transfer rate. These data rates are achieved by using a handshake wherein the data strobe and data transfer acknowledge signals are functionally decoupled and by specifying high current drivers for all data and control lines.

The enhanced pseudo-synchronous method of data transfer (hereinafter referred to as "fast transfer mode") is implemented so as to comply and be compatible with the IEEE VME backplane bus standard. The protocol utilizes user-defined address modifiers, defined in the VMEbus standard, to indicate use of the fast transfer mode. Conventional VMEbus functional units, capable only of implementing standard VMEbus protocols, will ignore transfers made using the fast transfer mode and, as a result, are fully compatible with functional units capable of implementing the fast transfer mode.

The fast transfer mode reduces the number of bus propagations required to accomplish a handshake from four propagations, as required under conventional VMEbus protocols, to only two bus propagations. Likewise, the number of bus propagations required to effect a BLOCK READ or BLOCK WRITE data transfer is reduced. Consequently, by reducing the propagations across the VMEbus to accomplish handshaking and data transfer functions, the transfer rate is materially increased.

The enhanced protocol is described in detail in the above-cited ENHANCED VMEBUS PROTOCOL application, and will only be summarized here. Familiarity with the conventional VME bus standards is assumed.

In the fast transfer mode handshake protocol, only two bus propagations are used to accomplish a handshake,

rather than four as required by the conventional protocol. At the initiation of a data transfer cycle, the master will assert and deassert DS0* in the form of a pulse of a given duration. The deassertion of DS0* is accomplished without regard as to whether a response has been received from the slave. The master then waits for an acknowledgement from the slave. Subsequent pulsing of DS0* cannot occur until a responsive DTACK* signal is received from the slave. Upon receiving the slave's assertion of DTACK*, the master can then immediately reassert data strobe, if so desired. The fast transfer mode protocol does not require the master to wait for the deassertion of DTACK* by the slave as a condition precedent to subsequent assertions of DS0*. In the fast transfer mode, only the leading edge (i.e., the assertion) of a signal is significant. Thus, the deassertion of either DS0* or DTACK* is completely irrelevant for completion of a handshake. The fast transfer protocol does not employ the DS1* line for data strobe purposes at all.

The fast transfer mode protocol may be characterized as pseudo-synchronous as it includes both synchronous and asynchronous aspects. The fast transfer mode protocol is synchronous in character due to the fact that DS0* is asserted and deasserted without regard to a response from the slave. The asynchronous aspect of the fast transfer mode protocol is attributable to the fact that the master may not subsequently assert DS0* until a response to the prior strobe is received from the slave. Consequently, because the protocol includes both synchronous and asynchronous components, it is most accurately classified as "pseudo-synchronous."

The transfer of data during a BLOCK WRITE cycle in the fast transfer protocol is referenced only to DS0*. The master first broadcasts valid data to the slave, and then asserts DS0 to the slave. The slave is given a predetermined period of time after the assertion of DS0* in which to capture the data. Hence, slave modules must be prepared to capture data at any time, as DTACK* is not referenced during the transfer cycle.

Similarly, the transfer of data during a BLOCK READ cycle in the fast transfer protocol is referenced only to DTACK*. The master first asserts DS0*. The slave then broadcasts data to the master and then asserts DTACK*. The master is given a predetermined period of time after the assertion of DTACK in which to capture the data. Hence, master modules must be prepared to capture data at any time as DS0 is not referenced during the transfer cycle.

Fig. 7, parts A through C, is a flowchart illustrating the operations involved in accomplishing the fast transfer protocol BLOCK WRITE cycle. To initiate a BLOCK WRITE cycle, the master broadcasts the memory address of the data to be transferred and the address modifier across the DTB bus. The master also drives interrupt acknowledge signal (IACK*) high and the LWORD* signal low 701. A special address modifier, for example "1F," broadcast by the master indicates to the slave module that the fast transfer protocol will be used to accomplish the BLOCK WRITE.

The starting memory address of the data to be transferred should reside on a 64-bit boundary and the size of block of data to be transferred should be a multiple of 64 bits. In order to remain in compliance with the VMEbus standard, the block must not cross a 256 byte boundary without performing a new address cycle.

The slave modules connected to the DTB receive the address and the address modifier broadcast by the master across the bus and receive LWORD* low and IACK* high 703. Shortly after broadcasting the address and address modifier 701, the master drives the AS* signal low 705. The slave modules receive the AS* low signal 707. Each slave individually determines whether it will participate in the data transfer by determining whether the broadcasted address is valid for the slave in question 709. If the address is not valid, the data transfer does not involve that particular slave and it ignores the remainder of the data transfer cycle.

The master drives WRITE* low to indicate that the transfer cycle about to occur is a WRITE operation 711. The slave receives the WRITE* low signal 713 and, knowing that the data transfer operation is a WRITE operation, awaits receipt of a high to low transition on the DS0* signal line 715. The master will wait until both DTACK* and BERR* are high 718, which indicates that the previous slave is no longer driving the DTB.

The master proceeds to place the first segment of the data to be transferred on data lines D00 through D31, 719. After placing data on D00 through D31, the master drives DS0* low 721 and, after a predetermined interval, drives DS0* high 723.

In response to the transition of DS0* from high to low, respectively 721 and 723, the slave latches the data being transmitted by the master over data lines D00 through D31, 725. The master places the next segment of the data to be transferred on data lines D00 through D31, 727, and awaits receipt of a DTACK* signal in the form of a high to low transition signal, 729 in Fig. 7B.

Referring to Fig. 7B, the slave then drives DTACK* low, 731, and, after a predetermined period of time, drives DTACK high, 733. The data latched by the slave, 725, is written to a device, which has been selected to store the data 735. The slave also increments the device address 735. The slave then waits for another transition of DS0* from high to low 737.

To commence the transfer of the next segment of the block of data to be transferred, the master drives DS0* low 739 and, after a predetermined period of time, drives DS0* high 741. In response to the transition of DS0* from high to low, respectively 739 and 741, the slave latches the data being broadcast by the master over data lines D00 through D31, 743. The master places the next segment of the data to be transferred on data lines D00 through D31, 745, and awaits receipt of a DTACK* signal in the form of a high to low transition, 747.

The slave then drives DTACK* low, 749, and, after a predetermined period of time, drives DTACK* high, 751. The

EP 0 490 973 B1

data latched by the slave, 743, is written to the device selected to store the data and the device address is incremented 753. The slave waits for another transition of DS0* from high to low 737.

5 The transfer of data will continue in the above-described manner until all of the data has been transferred from the master to the slave. After all of the data has been transferred, the master will release the address lines, address modifier lines, data lines, IACK* line, LWORD* line and DS0* line, 755. The master will then wait for receipt of a DTACK* high to low transition 757. The slave will drive DTACK* low, 759 and, after a predetermined period of time, drive DTACK* high 761. In response to the receipt of the DTACK* high to low transition, the master will drive AS* high 763 and then release the AS* line 765.

10 Fig. 8, parts A through C, is a flowchart illustrating the operations involved in accomplishing the fast transfer protocol BLOCK READ cycle. To initiate a BLOCK READ cycle, the master broadcasts the memory address of the data to be transferred and the address modifier across the DTB bus 801. The master drives the LWORD* signal low and the IACK* signal high 801. As noted previously, a special address modifier indicates to the slave module that the fast transfer protocol will be used to accomplish the BLOCK READ.

15 The slave modules connected to the DTB receive the address and the address modifier broadcast by the master across the bus and receive LWORD* low and IACK* high 803. Shortly after broadcasting the address and address modifier 801, the master drives the AS* signal low 805. The slave modules receive the AS* low signal 807. Each slave individually determines whether it will participate in the data transfer by determining whether the broadcasted address is valid for the slave in question 809. If the address is not valid, the data transfer does not involve that particular slave and it ignores the remainder of the data transfer cycle.

20 The master drives WRITE* high to indicate that the transfer cycle about to occur is a READ operation 811. The slave receives the WRITE* high signal 813 and, knowing that the data transfer operation is a READ operation, places the first segment of the data to be transferred on data lines D00 through D31 819. The master will wait until both DTACK* and BERR* are high 818, which indicates that the previous slave is no longer driving the DTB.

25 The master then drives DS0* low 821 and, after a predetermined interval, drives DS0* high 823. The master then awaits a high to low transition on the DTACK* signal line 824. As shown in Fig. 8B, the slave then drives the DTACK* signal low 825 and, after a predetermined period of time, drives the DTACK* signal high 827.

In response to the transition of DTACK* from high to low, respectively 825 and 827, the master latches the data being transmitted by the slave over data lines D00 through D31, 831. The data latched by the master, 831, is written to a device, which has been selected to store the data the device address is incremented 833.

30 The slave places the next segment of the data to be transferred on data lines D00 through D31, 829, and then waits for another transition of DS0* from high to low 837.

To commence the transfer of the next segment of the block of data to be transferred, the master drives DS0* low 839 and, after a predetermined period of time, drives DS0* high 841. The master then waits for the DTACK* line to transition from high to low, 843.

35 The slave drives DTACK* low, 845, and, after a predetermined period of time, drives DTACK* high, 847. In response to the transition of DTACK* from high to low, respectively 839 and 841, the master latches the data being transmitted by the slave over data lines D00 through D31, 845. The data latched by the master, 845, is written to the device selected to store the data, 851 in Fig. 8C, and the device address is incremented. The slave places the next segment of the data to be transferred on data lines D00 through D31, 849.

40 The transfer of data will continue in the above-described manner until all of the data to be transferred from the slave to the master has been written into the device selected to store the data. After all of the data to be transferred has been written into the storage device, the master will release the address lines, address modifier lines, data lines, the IACK* line, the LWORD line and DS0* line 852. The master will then wait for receipt of a DTACK* high to low transition 853. The slave will drive DTACK* low 855 and, after a predetermined period of time, drive DTACK* high 857. In response to the receipt of the DTACK* high to low transition, the master will drive AS* high 859 and release the AS* line 861.

45 To implement the fast transfer protocol, a conventional 64 mA tri-state driver is substituted for the 48 mA open collector driver conventionally used in VME slave modules to drive DTACK*. Similarly, the conventional VMEbus data drivers are replaced with 64 mA tri-state drivers in SO-type packages. The latter modification reduces the ground lead inductance of the actual driver package itself and, thus, reduces "ground bounce" effects which contribute to skew between data, DS0* and DTACK*. In addition, signal return inductance along the bus backplane is reduced by using a connector system having a greater number of ground pins so as to minimize signal return and mated-pair pin inductance. One such connector system is the "High Density Plus" connector, Model No. 420-8015-000, manufactured by Teradyne Corporation.

55

APPENDIX C

Parity FIFO

5 The parity FIFOs 240, 260 and 270 (on the network controllers 110), and 544 and 554 (on storage processors 114) are each implemented as an ASIC. All the parity FIFOs are identical, and are configured on power-up or during normal operation for the particular function desired. The parity FIFO is designed to allow speed matching between buses of different speed, and to perform the parity generation and correction for the parallel SCSI drives.

10 The FIFO comprises two bidirectional data ports, Port A and Port B, with 36 x 64 bits of RAM buffer between them. Port A is 8 bits wide and Port B is 32 bits wide. The RAM buffer is divided into two parts, each 36 x 32 bits, designated RAM X and RAM Y. The two ports access different halves of the buffer alternating to the other half when available. When the chip is configured as a parallel parity chip (e.g. one of the FIFOs 544 on SP 114a), all accesses on Port B are monitored and parity is accumulated in RAM X and RAM Y alternately.

15 The chip also has a CPU interface, which may be 8 or 16 bits wide. In 16 bit mode the Port A pins are used as the most significant data bits of the CPU interface and are only actually used when reading or writing to the Fifo Data Register inside the chip.

20 A REQ, ACK handshake is used for data transfer on both Ports A and B. The chip may be configured as either a master or a slave on Port A in the sense that, in master mode the Port A ACK / RDY output signifies that the chip is ready to transfer data on Port A, and the Port A REQ input specifies that the slave is responding. In slave mode, however, the Port A REQ input specifies that the master requires a data transfer, and the chip responds with Port A ACK / RDY when data is available. The chip is a master on Port B since it raises Port B REQ and waits for Port B ACK to indicate completion of the data transfer.

SIGNAL DESCRIPTIONS

25 Port A 0-7, P

Port A is the 8 bit data port. Port A P, if used, is the odd parity bit for this port.

30 A Req, A Ack/Rdy

These two signals are used in the data transfer mode to control the handshake of data on Port A.

35 uP Data 0-7, uP Data P, uPAdd 0-2, CS

These signals are used by a microprocessor to address the programmable registers within the chip. The odd parity signal uP Data P is only checked when data is written to the Fifo Data or Checksum Registers and microprocessor parity is enabled.

40 Clk

The clock input is used to generate some of the chip timing. It is expected to be in the 10-20 Mhz range.

45 Read En, Write En

During microprocessor accesses, while CS is true, these signals determine the direction of the microprocessor accesses. During data transfers in the WD mode these signals are data strobes used in conjunction with Port A Ack.

50 Port B 00-07, 10-17, 20-27, 30-37, 0P-3P

Port B is a 32 bit data port. There is one odd parity bit for each byte. Port B 0P is the parity of bits 00-07, Port B 1P is the parity of bits 10-17, Port B 2P is the parity of bits 20-27, and Port B 3P is the parity of bits 30-37.

55 B Select, B Req, B Ack, Parity Sync, B Output Enable

These signals are used in the data transfer mode to control the handshake of data on Port B. Port B Req and Port B Ack are both gated with Port B Select. The Port B Ack signal is used to strobe the data on the Port B data lines. The parity sync signal is used to indicate to a chip configured as the parity chip to indicate that the last words of data involved

EP 0 490 973 B1

in the parity accumulation are on Port B. The Port B data lines will only be driven by the Fifo chip if all of the following conditions are met:

- a. the data transfer is from Port A to Port B;
- 5 b. the Port B select signal is true;
- c. the Port B output enable signal is true; and
- d. the chip is not configured as the parity chip or it is in parity correct mode and the Parity Sync signal is true.

Reset

10 This signal resets all the registers within the chip and causes all bidirectional pins to be in a high impedance state.

DESCRIPTION OF OPERATION

15 Normal Operation. Normally the chip acts as a simple FIFO chip. A FIFO is simulated by using two RAM buffers in a simple ping-pong mode. It is intended, but not mandatory, that data is burst into or out of the FIFO on Port B. This is done by holding Port B Sel signal low and pulsing the Port B Ack signal. When transferring data from Port B to Port A, data is first written into RAM X and when this is full, the data paths will be switched such that Port B may start writing to RAM Y. Meanwhile the chip will begin emptying RAM X to Port A. When RAM Y is full and RAM X empty the data paths will be switched again such that Port B may reload RAM X and Port A may empty RAM Y.

20 Port A Slave Mode. This is the default mode and the chip is reset to this condition. In this mode the chip waits for a master such as one of the SCSI adapter chips 542 to raise Port A Request for data transfer. If data is available the Fifo chip will respond with Port A Ack/Rdy.

25 Port A WD Mode. The chip may be configured to run in the WD or Western Digital mode. In this mode the chip must be configured as a slave on Port A. It differs from the default slave mode in that the chip responds with Read Enable or Write Enable as appropriate together with Port A Ack/Rdy. This mode is intended to allow the chip to be interfaced to the Western Digital 33C93A SCSI chip or the NCR 53C90 SCSI chip.

30 Port A Master Mode. When the chip is configured as a master, it will raise Port A Ack/Rdy when it is ready for data transfer. This signal is expected to be tied to the Request input of a DMA controller which will respond with Port A Req when data is available. In order to allow the DMA controller to burst, the Port A Ack/Rdy signal will only be negated after every 8 or 16 bytes transferred.

35 Port B Parallel Write Mode. In parallel write mode, the chip is configured to be the parity chip for a parallel transfer from Port B to Port A. In this mode, when Port B Select and Port B Request are asserted, data is written into RAM X or RAM Y each time the Port B Ack signal is received. For the first block of 128 bytes data is simply copied into the selected RAM. The next 128 bytes driven on Port B will be exclusive-ORed with the first 128 bytes. This procedure will be repeated for all drives such that the parity is accumulated in this chip. The Parity Sync signal should be asserted to the parallel chip together with the last block of 128 bytes. This enables the chip to switch access to the other RAM and start accumulating a new 128 bytes of parity.

40 Port B Parallel Read Mode - Check Data. This mode is set if all drives are being read and parity is to be checked. In this case the Parity Correct bit in the Data Transfer Configuration Register is not set. The parity chip will first read 128 bytes on Port A as in a normal read mode and then raise Port B Request. While it has this signal asserted the chip will monitor the Port B Ack signals and exclusive-or the data on Port B with the data in its selected RAM. The Parity Sync should again be asserted with the last block of 128 bytes. In this mode the chip will not drive the Port B data lines but will check the output of its exclusive-or logic for zero. If any bits are set at this time a parallel parity error will be flagged.

45 Port B Parallel Read Mode - Correct Data. This mode is set by setting the Parity Correct bit in the Data Transfer Configuration Register. In this case the chip will work exactly as in the check mode except that when Port B Output Enable, Port B Select and Parity Sync are true the data is driven onto the Port B data lines and a parallel parity check for zero is not performed.

50 Byte Swap. In the normal mode it is expected that Port B bits 00-07 are the first byte, bits 10-17 the second byte, bits 20-27 the third byte, and bits 30-37 the last byte of each word. The order of these bytes may be changed by writing to the byte swap bits in the configuration register such that the byte address bits are inverted. The way the bytes are written and read also depend on whether the CPU interface is configured as 16 or 8 bits. The following table shows the byte alignments for the different possibilities for data transfer using the Port A Request / Acknowledge handshake:

55

CPU I/F	Invert Addr 1	Invert Addr 0	Port B 00-07	Port B 10-17	Port B 20-27	Port B 30-37
8	False	False	Port A	Port A	Port A	Port A

EP 0 490 973 B1

(continued)

CPU I/F	Invert Addr 1	Invert Addr 0	Port B 00-07 byte 0	Port B 10-17 byte 1	Port B 20-27 byte 2	Port B 30-37 byte 1
5 8	False	True	Port A byte 1	Port A byte 0	Port A byte 3	Port A byte 2
10 8	True	False	Port A byte 2	Port A byte 3	Port A byte 0	Port A byte 1
15 8	True	True	Port A byte 3	Port A byte 2	Port A byte 1	Port A byte 0
16 16	False	False	Port A byte 0	uProc byte 0	Port A byte 1	uProc byte 1
20 16	False	True	uProc byte 0	Port A byte 0	uProc byte 1	Port A byte 1
25 16	True	False	Port A byte 1	uProc byte 1	Port A byte 0	uProc byte 0
16	True	True	uProc byte 1	Port A byte 1	uProc byte 0	Port A byte 0

30 When the Fifo is accessed by reading or writing the Fifo Data Register through the microprocessor port in 8 bit mode, the bytes are in the same order as the table above but the uProc data port is used instead of Port A. In 16 bit mode the table above applies.

35 Odd Length Transfers. If the data transfer is not a multiple of 32 words, or 128 bytes, the microprocessor must manipulate the internal registers of the chip to ensure all data is transferred. Port A Ack and Port B Req are normally not asserted until all 32 words of the selected RAM are available. These signals may be forced by writing to the appropriate RAM status bits of the Data Transfer Status Register.

40 When an odd length transfer has taken place the microprocessor must wait until both ports are quiescent before manipulating any registers. It should then reset both of the Enable Data Transfer bits for Port A and Port B in the Data Transfer Control Register. It must then determine by reading their Address Registers and the RAM Access Control Register whether RAM X or RAM Y holds the odd length data. It should then set the corresponding Address Register to a value of 20 hexadecimal, forcing the RAM full bit and setting the address to the first word. Finally the microprocessor should set the Enable Data Transfer bits to allow the chip to complete the transfer.

45 At this point the Fifo chip will think that there are now a full 128 bytes of data in the RAM and will transfer 128 bytes if allowed to do so. The fact that some of these 128 bytes are not valid must be recognized externally to the FIFO chip.

PROGRAMMABLE REGISTERS

Data Transfer Configuration Register (Read/Write)

50 Register Address 0. This register is cleared by the reset signal.

55 Bit 0	<u>WD Mode.</u> Set if data transfers are to use the Western Digital WD33C93A protocol, otherwise the Adaptec 6250 protocol will be used.
Bit 1	<u>Parity Chip.</u> Set if this chip is to accumulate Port B parities.
Bit 2	<u>Parity Correct Mode.</u> Set if the parity chip is to correct parallel parity on Port B.

EP 0 490 973 B1

(continued)

5	Bit 3	<u>CPU Interface 16 bits wide</u> . If set, the microprocessor data bits are combined with the Port A data bits to effectively produce a 16 bit Port. All accesses by the microprocessor as well as all data transferred using the Port A Request and Acknowledge handshake will transfer 16 bits.
	Bit 4	<u>Invert Port A byte address 0</u> . Set to invert the least significant bit of Port A byte address.
10	Bit 5	<u>Invert Port A byte address 1</u> . Set to invert the most significant bit of Port A byte address.
	Bit 6	<u>Checksum Carry Wrap</u> . Set to enable the carry out of the 16 bit checksum adder to carry back into the least significant bit of the adder.
15	Bit 7	<u>Reset</u> . Writing a 1 to this bit will reset the other registers. This bit resets itself after a maximum of 2 clock cycles and will therefore normally be read as a 0. No other register should be written for a minimum of 4 clock cycles after writing to this bit.

Data Transfer Control Register (Read/Write)

20

Register Address 1. This register is cleared by the reset signal or by writing to the reset bit.

25	Bit 0	<u>Enable Data Transfer on Port A</u> . Set to enable the Port A Req/Ack handshake.
	Bit 1	<u>Enable Data Transfer on Port B</u> . Set to enable the Port B Req/Ack handshake.
30	Bit 2	<u>Port A to Port B</u> . If set, data transfer is from Port A to Port B. If reset, data transfer is from Port B to Port A. In order to avoid any glitches on the request lines, the state of this bit should not be altered at the same time as the enable data transfer bits 0 or 1 above.
	Bit 3	<u>uProcessor Parity Enable</u> . Set if parity is to be checked on the microprocessor interface. It will only be checked when writing to the Fifo Data Register or reading from the Fifo Data or Checksum Registers, or during a Port A Request/Acknowledge transfer in 16 bit mode. The chip will, however, always re-generate parity ensuring that correct parity is written to the RAM or read on the microprocessor interface.
35	Bit 4	<u>Port A Parity Enable</u> . Set if parity is to be checked on Port A. It is checked when accessing the Fifo Data Register in 16 bit mode, or during a Port A Request/Acknowledge transfer. The chip will, however, always re-generate parity ensuring that correct parity is written to the RAM or read on the Port A interface.
40	Bit 5	<u>Port B Parity Enable</u> . Set if Port B data has valid byte parities. If it is not set, byte parity is generated internally to the chip when writing to the RAMs. Byte parity is not checked when writing from Port B, but always checked when reading to Port B.
45	Bit 6	<u>Checksum Enable</u> . Set to enable writing to the 16 bit checksum register. This register accumulates a 16 bit checksum for all RAM accesses, including accesses to the Fifo Data Register, as well as all writes to the checksum register. This bit must be reset before reading from the Checksum Register.
	Bit 7	<u>Port A Master</u> . Set if Port A is to operate in the master mode on Port A during the data transfer.

50

Data Transfer Status Register (Read Only)

Register Address 2. This register is cleared by the reset signal or by writing to the reset bit.

55	Bit 0	<u>Data in RAM X or RAM Y</u> . Set if any bits are true in the RAM X, RAM Y, or Port A byte address registers.
----	-------	-----------------------------------------------------------------------------------------------------------------

EP 0 490 973 B1

(continued)

5	Bit 1	<u>uProc Port Parity Error</u> . Set if the uProc Parity Enable bit is set and a parity error is detected on the microprocessor interface during any RAM access or write to the Checksum Register in 16 bit mode.
	Bit 2	<u>Port A Parity Error</u> . Set if the Port A Parity Enable bit is set and a parity error is detected on the Port A interface during any RAM access or write to the Checksum Register.
10	Bit 3	<u>Port B Parallel Parity Error</u> . Set if the chip is configured as the parity chip, is not in parity correct mode, and a non zero result is detected when the Parity Sync signal is true. It is also set whenever data is read out onto Port B and the data being read back through the bidirectional buffer does not compare.
15	Bits 4-7	<u>Port B Bytes 0-3 Parity Error</u> . Set whenever the data being read out of the RAMs on the Port B side has bad parity.

Ram Access Control Register (Read/Write)

Register Address 3. This register is cleared by the reset signal or by writing to the reset bit. The Enable Data Transfer bits in the Data Transfer Control Register must be reset before attempting to write to this register, else the write will be ignored.

25	Bit 0	<u>Port A byte address 0</u> . This bit is the least significant byte address bit. It is read directly bypassing any inversion done by the invert bit in the Data Transfer Configuration Register.
	Bit 1	<u>Port A byte address 1</u> . This bit is the most significant byte address bit. It is read directly bypassing any inversion done by the invert bit in the Data Transfer Configuration Register.
30	Bit 2	<u>Port A to RAM Y</u> . Set if Port A is accessing RAM Y, and reset if it is accessing RAM X.
	Bit 3	<u>Port B to RAM Y</u> . Set if Port B is accessing RAM Y, and reset if it is accessing RAM X.
35	Bit 4	<u>Long Burst</u> . If the chip is configured to transfer data on Port A as a master, and this bit is reset, the chip will only negate Port A Ack/Rdy after every 8 bytes, or 4 words in 16 bit mode, have been transferred. If this bit is set, Port A Ack/Rdy will be negated every 16 bytes, or 8 words in 16 bit mode.
	Bits 5-7	<u>Not Used</u> .

40 RAM X Address Register (Read/Write)

Register Address 4. This register is cleared by the reset signal or by writing to the reset bit. The Enable Data Transfer bits in the Data Transfer Control Register must be reset before attempting to write to this register, else the write will be ignored.

Bits 0-4	RAM X word address
Bit 5	RAM X full
Bits 6-7	Not Used

50 RAM Y Address Register (Read/Write)

Register Address 5. This register is cleared by the reset signal or by writing to the reset bit. The Enable Data Transfer bits in the Data Transfer Control Register must be reset before attempting to write to this register, else the write will be ignored.

Bits 0-4	RAM Y word address
Bit 5	RAM Y full

EP 0 490 973 B1

(continued)

Bits 6-7	Not Used
----------	----------

5 Fifo Data Register (Read/Write)

Register Address 6. The Enable Data Transfer bits in the Data Transfer Control Register must be reset before attempting to write to this register, else the write will be ignored. The Port A to Port B bit in the Data Transfer Control register must also be set before writing this register. If it is not, the RAM controls will be incremented but no data will be written to the RAM. For consistency, the Port A to PortB should be reset prior to reading this register.

10 Bits 0-7 are Fifo Data. The microprocessor may access the FIFO by reading or writing this register. The RAM control registers are updated as if the access was using Port A. If the chip is configured with a 16 bit CPU Interface the most significant byte will use the Port A 0-7 data lines, and each Port A access will increment the Port A byte address by 2.

15

Port A Checksum Register (Read/Write)

Register Address 7. This register is cleared by the reset signal or by writing to the reset bit.

20 Bits 0-7 are Checksum Data. The chip will accumulate a 16 bit checksum for all Port A accesses. If the chip is configured with a 16 bit CPU interface, the most significant byte is read on the Port A 0-7 data lines. If data is written directly to this register it is added to the current contents rather than overwriting them. It is important to note that the Checksum Enable bit in the Data Transfer Control Register must be set to write this register and reset to read it.

PROGRAMMING THE FIFO CHIP

25

In general the fifo chip is programmed by writing to the data transfer configuration and control registers to enable a data transfer, and by reading the data transfer status register at the end of the transfer to check the completion status. Usually the data transfer itself will take place with both the Port A and the Port B handshakes enabled, and in this case the data transfer itself should be done without any other microprocessor interaction. In some applications, however, the Port A handshake may not be enabled, and it will be necessary for the microprocessor to fill or empty the fifo by repeatedly writing or reading the Fifo Data Register.

30

Since the fifo chip has no knowledge of any byte counts, there is no way of telling when any data transfer is complete by reading any register within this chip itself. Determination of whether the data transfer has been completed must therefore be done by some other circuitry outside this chip.

35

The following C language routines illustrate how the parity FIFO chip may be programmed. The routines assume that both Port A and the microprocessor port are connected to the system microprocessor, and return a size code of 16 bits, but that the hardware addresses the Fifo chip as long 32 bit registers.

40

45

50

55

```

struct FIFO_regs {
    unsigned char config,a1,a2,a3 ;
    unsigned char control,b1,b2,b3;
5    unsigned char status,c1,c2,c3;
    unsigned char ram_access_control,d1,d2,d3;
    unsigned char ram_X_addr,e1,e2,e3;
    unsigned char ram_Y_addr,f1,f2,f3;
    unsigned long data;
10    unsigned int checksum,h1;
};

#define FIFO1 ((struct FIFO_regs*) FIFO_BASE_ADDRESS)

15    #define FIFO_RESET 0x80
    #define FIFO_16_BITS 0x08
    #define FIFO_CARRY_WRAP 0x40
    #define FIFO_PORT_A_ENABLE 0x01
    #define FIFO_PORT_B_ENABLE 0x02
20    #define FIFO_PORT_ENABLES 0x03
    #define FIFO_PORT_A_TO_B 0x04
    #define FIFO_CHECKSUM_ENABLE 0x40
    #define FIFO_DATA_IN_RAM 0x01
    #define FIFO_FORCE_RAM_FULL 0x20
25

    #define PORT_A_TO_PORT_B(fifo) ((fifo-> control ) & 0x04)
    #define PORT_A_BYTE_ADDRESS(fifo) ((fifo->ram_access_control) &
    0x03)
    #define PORT_A_TO_RAM_Y(fifo) ((fifo->ram_access_control ) & 0x04)
30    #define PORT_B_TO_RAM_Y(fifo) ((fifo-> ram_access_control ) & 0x08)

35

40

45

50

55

```



```

/*****
    The following routine initiates a Fifo data transfer using two
    values passed to it.
5
    config_data This is the data to be written to the configuration register.

    control_data This is the data to be written to the Data Transfer Control
10
    Register. If the data transfer is to take place
    automatically using both the Port A and Port B
    handshakes, both data transfer enables bits should be
    set in this parameter.
    *****/

15
FIFO_initiate_data_transfer(config_data, control_data)
unsigned char config_data, control_data;
{
    FIFO1->config = config_data | FIFO_RESET; /* Set
20
    Configuration value & Reset */
    FIFO1->control = control_data & (~FIFO_PORT_ENABLES); /* Set
    everything but enables */
    FIFO1->control = control_data; /* Set data transfer
25
    enables */
}

/*****
    The following routine forces the transfer of any odd bytes that
    have been left in the Fifo at the end of a data transfer.
    It first disables both ports, then forces the Ram Full bits, and then
30
    re-enables the appropriate Port.
    *****/

FIFO_force_odd_length_transfer()
35
{
    FIFO1->control &= ~FIFO_PORT_ENABLES; /* Disable Ports A & B
    */
    if (PORT_A_TO_PORT_B(FIFO1)) {
        if (PORT_A_TO_RAM_Y(FIFO1)) {
40
            FIFO1->ram_Y_addr = FIFO_FORCE_RAM_FULL; /*
            Set RAM Y full */
        }
        else FIFO1->ram_X_addr = FIFO_FORCE_RAM_FULL; /* Set
        RAM X full */
45
        FIFO1->control |= FIFO_PORT_B_ENABLE; /*
        Re-Enable Port B */
    }
    else {
50
        if (PORT_B_TO_RAM_Y(FIFO1)) {
            FIFO1->ram_Y_addr = FIFO_FORCE_RAM_FULL; /*
            Set RAM Y full */
        }
        else FIFO1->ram_X_addr = FIFO_FORCE_RAM_FULL; /* Set
55
        RAM X full */
    }
}

```

```

        FIFO1->control |= FIFO_PORT_A_ENABLE;    /*
Re-Enable Port A */
5      }
}

/*****
The following routine returns how many odd bytes have been
left in the Fifo at the end of a data transfer.
10 *****/

int FIFO_count_odd_bytes()
{
15     int number_odd_bytes;
    number_odd_bytes=0;
    if (FIFO1->status & FIFO_DATA_IN_RAM) {
        if (PORT_A_TO_PORT_B(FIFO1)) {
            number_odd_bytes =
20     (PORT_A_BYTE_ADDRESS(FIFO1));
            if (PORT_A_TO_RAM_Y(FIFO1))
                number_odd_bytes += (FIFO1->ram_Y_addr) *
4;
            else number_odd_bytes += (FIFO1->ram_X_addr) * 4;
        }
        else {
            if (PORT_B_TO_RAM_Y(FIFO1))
                number_odd_bytes = (FIFO1->ram_Y_addr) * 4;
            else number_odd_bytes = (FIFO1->ram_X_addr) * 4;
        }
    }
    return (number_odd_bytes);
}

/*****
35 The following routine tests the microprocessor interface of the
chip. It first writes and reads the first 6 registers. It then writes 1s, 0s, and
an address pattern to the RAM, reading the data back and checking it.

40 The test returns a bit significant error code where each bit
represents the address of the registers that failed.

    Bit 0 = config register failed
    Bit 1 = control register failed
    Bit 2 = status register failed
45    Bit 3 = ram access control register failed
    Bit 4 = ram X address register failed
    Bit 5 = ram Y address register failed
    Bit 6 = data register failed
    Bit 7 = checksum register failed
50 *****/

#define RAM_DEPTH 64      /* number of long words in Fifo Ram */
55 reg_expected_data[6] = { 0x7F, 0xFF, 0x00, 0x1F, 0x3F, 0x3F };

```

```

char FIFO_uprocessor_interface_test()
{
    unsigned long test_data;
    char *register_addr;
    int i;
    char j,error;
    FIFO1->config = FIFO_RESET;          /* reset the chip */
    error=0;
    register_addr =(char *) FIFO1;
    j=1;

    /* first test registers 0 thru 5 */

    for (i=0; i<6; i++) {
        *register_addr = 0xFF;          /* write test data */
        if (*register_addr != reg_expected_data[i]) error |= j;
        *register_addr = 0;            /* write 0s to register */
        if (*register_addr error |= j;
        *register_addr = 0xFF;          /* write test data again */
        if (*register_addr != reg_expected_data[i]) error |= j;
        FIFO1->config = FIFO_RESET;     /* reset the chip */
        if (*register_addr error |= j; /* register should be 0 */
        register_addr++;               /* go to next register */
        j <<= 1;
    }

    /* now test Ram data & checksum registers
    test 1s throughout Ram & then test 0s */

    for (test_data = -1; test_data != 1; test_data++) { /* test for 1s
    & 0s */
        FIFO1->config = FIFO_RESET | FIFO_16_BITS ;
        FIFO1->control = FIFO_PORT_A_TO_B;
        for (i=0;i<RAM_DEPTH;i++) /* write data to RAM
        */
            FIFO1->data = test_data;
        FIFO1->control = 0;
        for (i=0;i<RAM_DEPTH;i++)
            if (FIFO1->data != test_data) error |= j; /* read &
        check data */
        if (FIFO1->checksum) error |= 0x80; /* checksum
        should = 0 */
    }

    /* now test Ram data with address pattern
    uses a different pattern for every byte */

    test_data=0x00010203; /* address pattern start */
    FIFO1->config = FIFO_RESET | FIFO_16_BITS |
    FIFO_CARRY_WRAP;
    FIFO1->control = FIFO_PORT_A_TO_B |
    FIFO_CHECKSUM_ENABLE;
    for (i=0;i<RAM_DEPTH;i++) {
        FIFO1->data = test_data; /* write address pattern */
    }
}

```

```

    test_data += 0x04040404;
}
test_data=0x00010203; /* address pattern start */
5 FIFO1->control = FIFO_CHECKSUM_ENABLE;
for (i=0;i<RAM_DEPTH;i++) {
    if (FIFO1->status != FIFO_DATA_IN_RAM)
        error |= 0x04; /* should be data in ram */
    if (FIFO1->data != test_data) error |= j; /* read & check
10 address pattern */
    test_data += 0x04040404;
}
if (FIFO1->checksum != 0x0102) error |= 0x80; /* test checksum of
address pattern */
15 FIFO1->config = FIFO_RESET | FIFO_16_BITS ; /* inhibit carry wrap
*/
FIFO1->checksum = 0xFEFE; /* writing adds to checksum */
if (FIFO1->checksum) error |= 0x80; /* checksum should be 0
*/
20 if (FIFO1->status) error |= 0x04; /* status should be 0 */
return (error);
}

```

25

Claims

1. Network server apparatus (100) for use with a first data network (122a) and a mass storage device, including a host processor unit (118) capable of running remote procedures defined by a client node on said network, characterised in that said network server apparatus further comprises:

30

an interface processor unit coupleable to said network and to said mass storage device; and means (110a, 112a, 114a, 116a, 120) in said interface processor unit for satisfying network storage requests from said network to store data from said network in said mass storage device, for satisfying network retrieval requests from said network to retrieve data from said mass storage device to said network, and for transmitting predefined categories of messages from said network to said host processor unit for processing in said host processor unit, said transmitted messages including all requests by a network client to run client-defined procedures on said network server apparatus.

35

2. Apparatus according to claim 1, wherein said interface processor unit comprises:

40

a network control unit (110a) coupleable to said network (122a);
a data control unit (112a, 114a) coupleable to said mass storage device;
a buffer memory (116a); and
45 means (210,212,214,220,222,224,232,234,236,252,254,256) in said network control unit:
for transmitting to said data control unit said network storage requests from said network to store specified storage data from said network in said mass storage device,
for transmitting said specified storage data from said network to said buffer memory and from said buffer memory to said data control unit,
50 for transmitting to said data control unit said network retrieval requests from said network to retrieve specified retrieval data from said mass storage device to said network,
for transmitting said specified retrieval data from said data control unit to said buffer memory and from said buffer memory to said network, and
for transmitting said predefined categories of messages from said network to said host processor unit for processing by said host processor unit.

55

3. Apparatus according to claim 2, wherein said data control unit comprises:

a storage processor unit (114a) coupleable to said mass storage device;
 a file processor unit (112a) and
 means (310,312,314,320,324,390,396) in said file processor unit;
 for translating said network storage requests from said network into requests to store data at specified physical
 5 storage locations in said mass storage device,
 for instructing said storage processor unit to write data from said buffer memory into said specified physical
 storage locations in said mass storage device,
 for translating said network retrieval requests from said network into requests to retrieve data from specified
 physical retrieval locations in said mass storage device, and
 10 for instructing said storage processor unit to retrieve data from said specified physical retrieval locations in
 said mass storage device to said buffer memory if said data from said specified physical locations is not already
 in said buffer memory; and
 means (510,512,514,524,532,534) in said storage processor unit for transmitting data between said buffer
 15 memory and said mass storage device.

4. Apparatus according to claim 1, wherein said interface processor unit comprises:

a network control module (110a), including a network interface (234; 214) coupled to receive said network
 20 retrieval requests from said network;
 a file system control module (112a, 114a), including a mass storage device interface (540, 514) coupled to
 said mass storage device; and
 a communication path (120) coupled directly between said network control module and said file system control
 module, said communication path carrying local retrieval requests prepared by said network control module
 25 in response to said network retrieval requests, to retrieve specified retrieval data from said mass storage
 device,
 said file system control module retrieving said specified retrieval data from said mass storage device in re-
 sponse to said local retrieval requests and returning said specified retrieval data to said network control module,
 and said network control module preparing reply messages containing said specified retrieval data from said
 30 file system control module for return transmission on said network.

5. Apparatus according to claim 4, wherein said file system control module returns said specified retrieval data directly
 to said network control module.

6. Apparatus according to claim 4 or 5, wherein said network interface is coupled further to receive said network
 35 storage requests from said network, wherein said network control module further prepares local storage requests
 in response to said network storage requests, to store specified storage data in said mass storage device, said
 network control module communicating said local storage requests to said file system control module,
 and wherein said file system control module further stores said specified storage data in said mass storage
 40 device in response to said local storage requests.

7. Apparatus according to claim 6, wherein said local storage requests are communicated to said file system control
 module via said communication path (120).

8. Apparatus according to any preceding claim, wherein said host processor unit runs a general purpose operating
 45 system, and wherein said interface processor unit runs no general purpose operating system.

9. Apparatus according to claim 8, wherein said general purpose operating system run on said host processor unit
 is a UNIX operating system.

10. Apparatus according to any preceding claim, wherein said interface processor unit includes means (214, 314, 514)
 50 for decoding all network file system NFS requests addressed to said interface processing unit from said network,
 for performing all procedures for satisfying said NFS requests, and for encoding any NFS reply messages for return
 transmission on said network.

11. Apparatus according to any preceding claim, wherein said transmitted messages include all calls issued by a
 55 network client to said network server apparatus which are within a predefined set of remote procedure calls.

12. Apparatus according to any preceding claim, further comprising means in said interface processor unit for detecting

requests from said network for an address of said network server apparatus, for preparing a response packet to such an address request, and for transmitting said response packet over said network.

- 5 13. Apparatus according to any preceding claim, for use further with a second data network (122b), said interface processor unit being coupleable further to said second network, further comprising means (210, 214, 230, 250, 234, 254) in said interface processor unit for detecting a request from said first network to route a message contained in certain packets to a destination reachable over said second network, and means for transmitting said message over said second network.

10

Patentansprüche

- 15 1. Netzwerkservorrichtung (100) zur Verwendung mit einem ersten Datennetz (122a) und einer Massenspeichereinrichtung, umfassend eine Zentralrechnereinheit (118), die zum Ausführen von durch einen Clientknoten im Netzwerk definierten Fernprozeduren geeignet ist, dadurch gekennzeichnet, daß die Netzwerkservorrichtung ferner umfaßt:

eine Schnittstellenprozessoreinheit, die an das Netzwerk und an die Massenspeichereinrichtung koppelbar ist; und

20

Mittel (110a, 112a, 114a, 116a, 120) in der Schnittstellenprozessoreinheit zum Befriedigen von Netzwerkspeicheranforderungen aus dem Netzwerk, Daten aus dem Netzwerk in der Massenspeichereinrichtung zu speichern, zum Befriedigen von Netzwerkausleseanforderungen vom Netzwerk, Daten aus der Massenspeichereinrichtung zum Netzwerk auszulesen und zum Übertragen vorbestimmter Kategorien von Mitteilungen aus dem Netzwerk zur Zentralrechnereinheit zum Verarbeiten in der Zentralrechnereinheit, wobei die übertragenen Mitteilungen alle Anforderungen durch einen Netzwerkclient enthalten, clientdefinierte Prozeduren auf der Netzwerkservorrichtung auszuführen.

25

2. Vorrichtung nach Anspruch 1, wobei die Schnittstellenprozessoreinheit umfaßt:

30

eine an das Netzwerk (122a) koppelbare Netzwerksteuereinheit (110a);
eine an die Massenspeichereinrichtung koppelbare Datensteuereinheit (112a, 114a);
einen Pufferspeicher (116a); und
Mittel (210, 212, 214, 220, 222, 224, 232, 234, 236, 252, 254, 256) in der Netzwerksteuereinheit:
zum Übertragen der Netzwerkspeicheranforderungen aus dem Netzwerk zu der Datensteuereinheit, um bestimmte Speicherdaten aus dem Netzwerk in der Massenspeichereinrichtung zu speichern,
35 zum Übertragen der bestimmten Speicherdaten aus dem Netzwerk zum Pufferspeicher und aus dem Pufferspeicher zur Datensteuereinheit,
zum Übertragen der Netzwerkausleseanforderungen aus dem Netzwerk zur Datensteuereinheit, um bestimmte Auslesedaten aus der Massenspeichereinrichtung zum Netzwerk auszulesen,
40 zum Übertragen der bestimmten Auslesedaten aus der Datensteuereinheit zum Pufferspeicher und aus dem Pufferspeicher zum Netzwerk, und
zum Übertragen der vorbestimmten Kategorien von Mitteilungen aus dem Netzwerk zur Zentralrechnereinheit zum Verarbeiten durch die Zentralrechnereinheit.

40

- 45 3. Vorrichtung nach Anspruch 2, wobei die Datensteuereinheit umfaßt:

eine an die Massenspeichereinrichtung koppelbare Speicherprozessoreinheit (114a);
eine Dateiprozessoreinheit (112a) und
Mittel (310, 312, 314, 320, 324, 390, 396) in der Dateiprozessoreinheit: zum Übersetzen der Netzwerkspeicheranforderungen aus dem Netzwerk in Anforderungen, Daten an bestimmten physikalischen Speicherstellen in der Massenspeichereinrichtung zu speichern,
50 zum Anweisen der Speicherprozessoreinheit, Daten aus dem Pufferspeicher in die bestimmten physikalischen Speicherstellen in der Massenspeichereinrichtung zu schreiben,
zum Übersetzen der Netzwerkausleseanforderungen aus dem Netzwerk in Anforderungen, Daten von bestimmten physikalischen Auslestellen in der Massenspeichereinrichtung auszulesen, und
55 zum Anweisen der Speicherprozessoreinheit, Daten von den bestimmten physikalischen Auslestellen in der Massenspeichereinrichtung zum Pufferspeicher auszulesen, wenn die Daten von den bestimmten physikalischen Stellen nicht bereits im Pufferspeicher sind; und

50

55

EP 0 490 973 B1

Mittel (510, 512, 514, 524, 532, 534) in der Speicherprozessoreinheit zum Übertragen von Daten zwischen dem Pufferspeicher und der Massenspeichereinrichtung.

- 5 4. Vorrichtung nach Anspruch 1, wobei die Schnittstellenprozessoreinheit umfaßt:
- ein Netzwerksteuermodul (110a), umfassend eine Netzwerkschnittstelle (234; 214), die angekoppelt ist, um die Netzwerkausleseanforderungen aus dem Netzwerk zu empfangen;
ein Dateisystemsteuermodul (112a, 114a), umfassend eine Massenspeichereinrichtungsschnittstelle (540; 514), die an die Massenspeichereinrichtung gekoppelt ist; und
10 einen Kommunikationsweg (120), der direkt zwischen dem Netzwerksteuermodul und dem Dateisystemsteuermodul angekoppelt ist, wobei der Kommunikationsweg lokale Ausleseanforderungen führt, die durch das Netzwerksteuermodul in Antwort auf die Netzwerkausleseanforderungen vorbereitet sind, um bestimmte Auslesedaten aus der Massenspeichereinrichtung auszulesen,
15 wobei das Dateisystemsteuermodul die bestimmten Auslesedaten aus der Massenspeichereinrichtung in Antwort auf die lokalen Ausleseanforderungen ausliest und die bestimmten Auslesedaten zu dem Netzwerksteuermodul zurückgibt,
und wobei das Netzwerksteuermodul Antwortmitteilungen vorbereitet, die die bestimmten Auslesedaten vom Dateisystemsteuermodul enthalten, zur Rückübertragung auf das Netzwerk.
- 20 5. Vorrichtung nach Anspruch 4, wobei das Dateisystemsteuermodul die bestimmten Auslesedaten direkt zum Netzwerksteuermodul zurückgibt.
6. Vorrichtung nach Anspruch 4 oder 5, wobei die Netzwerkschnittstelle ferner angekoppelt ist, um die Netzwerk-speicheranforderungen aus dem Netzwerk zu empfangen, wobei das Netzwerksteuermodul ferner lokale Speicheranforderungen in Antwort auf die Netzwerkspeicheranforderungen vorbereitet, bestimmte Speicherdaten in
25 der Massenspeichereinrichtung zu speichern, wobei das Netzwerksteuermodul die lokalen Speicheranforderungen dem Dateisystemsteuermodul mitteilt,
und wobei das Dateisystemsteuermodul ferner die bestimmten Speicherdaten in der Massenspeichereinrichtung in Antwort auf lokale Speicheranforderungen speichert.
- 30 7. Vorrichtung nach Anspruch 6, wobei die lokalen Speicheranforderungen dem Dateisystemsteuermodul über den Kommunikationsweg (120) mitgeteilt werden.
8. Vorrichtung nach einem der vorangegangenen Ansprüche, wobei die Zentralrechnereinheit ein universelles Betriebssystem ausführt, und wobei die Schnittstellenprozessoreinheit kein universelles Betriebssystem ausführt.
- 35 9. Vorrichtung nach Anspruch 8, wobei das auf der Zentralprozessoreinheit ausgeführte universelle Betriebssystem ein UNIX-Betriebssystem ist.
- 40 10. Vorrichtung nach einem der vorangegangenen Ansprüche, wobei die Schnittstellenprozessoreinheit Mittel (214, 314, 514) zum Dekodieren aller Netzwerkdateisystem-NFS-Anforderungen, die vom Netzwerk an die Schnittstellenverarbeitungseinheit gerichtet sind, um alle Prozeduren zum Befriedigen der NFS-Anforderungen durchzuführen, und um NFS-Antwortmitteilungen zur Rückübertragung auf das Netzwerk zu kodieren.
- 45 11. Vorrichtung nach einem der vorangegangenen Ansprüche, wobei die übertragenen Mitteilungen alle durch einen Netzwerkclient an die Netzwerkservorrichtung ausgegebenen Aufrufe umfassen, die in einem vorbestimmten Satz von Fernprozeduraufrufen sind.
- 50 12. Vorrichtung nach einem der vorangegangenen Ansprüche, ferner umfassend Mittel in der Schnittstellenprozessoreinheit zum Erfassen von Anforderungen aus dem Netzwerk für eine Adresse der Netzwerkservorrichtung, zum Vorbereiten eines Antwortpakets für eine derartige Adressenanforderung, und zum Übertragen des Antwortpakets über das Netzwerk.
- 55 13. Vorrichtung nach einem der vorangegangenen Ansprüche, zur Verwendung mit einem zweiten Datennetzwerk (122b), wobei die Schnittstellenprozessoreinheit ferner an das zweite Netzwerk koppelbar ist, ferner umfassend Mittel (210, 214, 230, 250, 234, 254) in der Schnittstellenprozessoreinheit zum Erfassen einer Anforderung vom ersten Netzwerk, um eine in gewissen Paketen enthaltene Mitteilung an ein über das zweite Netzwerk erreichbares Ziel zu leiten, und Mittel zum Übertragen der Mitteilung über das zweite Netzwerk.

Revendications

1. Dispositif serveur de réseau (100) destiné à être utilisé avec un premier réseau de données (122a) et un dispositif de stockage de masse, comprenant une unité à processeur hôte (118) capable d'exécuter des procédures à distance définies par un noeud client sur ledit réseau, caractérisé en ce que ledit dispositif serveur de réseau comprend en outre :
- une unité d'interface à processeur pouvant être couplée audit réseau et audit dispositif de stockage de masse ;
et
des moyens (110a, 112a, 114a, 116a, 120) dans ladite unité d'interface à processeur destinés à satisfaire des demandes de stockage réseau à partir dudit réseau pour stocker des données à partir dudit réseau dans ledit dispositif de stockage de masse, destinés à satisfaire des demandes de recherches réseau à partir dudit réseau pour rechercher des données à partir dudit dispositif de stockage de masse vers ledit réseau, et destinés à transmettre des catégories prédéfinies de messages à partir dudit réseau vers ladite unité à processeur hôte afin de traiter dans ladite unité à processeur hôte, lesdits messages transmis comprenant toutes les demandes par un client du réseau pour exécuter des procédures définies par le client sur ledit dispositif serveur de réseau.
2. Dispositif selon la revendication 1, dans lequel ladite unité d'interface à processeur comprend :
- une unité de régulation du réseau (110a) pouvant être couplée audit réseau (122a) ;
une unité de régulation de données (112a, 114a) pouvant être couplée audit dispositif de stockage de masse ;
une mémoire tampon (116a) ; et
des moyens (210, 212, 214, 220, 222, 224, 232, 234, 236, 252, 254, 256) dans ladite unité de régulation du réseau :
destinés à transmettre vers ladite unité de régulation de données lesdites demandes de stockage réseau à partir dudit réseau pour stocker des données de stockage spécifiées à partir dudit réseau dans ledit dispositif de stockage de masse,
destinés à transmettre lesdites données de stockage spécifiées à partir dudit réseau vers ladite mémoire tampon et à partir de ladite mémoire tampon vers ladite unité de régulation de données,
destinés à transmettre vers ladite unité de régulation de données lesdites demandes de recherches réseau à partir dudit réseau pour rechercher des données de recherches spécifiées à partir dudit dispositif de stockage de masse vers ledit réseau,
destinés à transmettre lesdites données de recherches spécifiées à partir de ladite unité de régulation de données vers ladite mémoire tampon et à partir de ladite mémoire tampon vers ledit réseau, et
destinés à transmettre lesdites catégories prédéfinies de messages à partir dudit réseau vers ladite unité à processeur hôte afin d'être traitées par ladite unité à processeur hôte.
3. Dispositif selon la revendication 2, dans lequel ladite unité de régulation de données comprend :
- une unité de stockage à processeur (114a) pouvant être couplée audit dispositif de stockage de masse ;
une unité de fichier à processeur (112a) ; et
des moyens (310, 312, 314, 320, 324, 390, 396) dans ladite unité de fichiers à processeur :
destinés à traduire lesdites demandes de stockage réseau à partir dudit réseau en demandes pour stocker des données à des emplacements spécifiés de stockage physique dans ledit dispositif de stockage de masse, destinés à donner l'ordre à ladite unité de stockage à processeur d'écrire des données à partir de ladite mémoire tampon dans lesdits emplacements spécifiés de stockage physiques dans ledit dispositif de stockage de masse,
destinés à traduire lesdites demandes de recherches réseau à partir dudit réseau en demandes pour rechercher des données à partir des emplacements spécifiés de recherches physiques dans ledit dispositif de stockage de masse, et
destinés à donner l'ordre à ladite unité de stockage à processeur de rechercher des données à partir desdits emplacements spécifiés de recherches physiques dans ledit dispositif de stockage de masse vers ladite mémoire tampon si lesdites données à partir desdits emplacements spécifiés physiques ne sont pas déjà dans ladite mémoire tampon ; et
des moyens (510, 512, 514, 524, 532, 534) dans ladite unité de stockage à processeur destinés à transmettre des données entre ladite mémoire tampon et ledit dispositif de stockage de masse.

4. Dispositif selon la revendication 1, dans lequel ladite unité d'interface à processeur comprend :
- un module de régulation du réseau (110a), comprenant une interface réseau (234, 214) couplée pour recevoir lesdites demandes de recherches réseau à partir dudit réseau ;
 - 5 un module de régulation du système fichier (112a, 114a), comprenant une interface pour dispositif de stockage de masse (540, 514) couplée audit dispositif de stockage de masse ; et
 - un chemin de communication (120) directement couplé entre ledit module de régulation du réseau et ledit module de régulation du système fichier, ledit chemin de communication transportant des demandes de recherches locales préparées par ledit module de régulation du réseau en réponse auxdites demandes de recherches réseau, afin de rechercher des données de recherches spécifiées à partir dudit dispositif de stockage de masse,
 - 10 ledit module de régulation du système fichier recherchant lesdites données de recherches spécifiées à partir du dispositif de stockage de masse en réponse auxdites demandes de recherches locales et retournant lesdites données de recherches spécifiées vers ledit module de régulation du réseau,
 - 15 et ledit module de régulation du réseau préparant des messages de réponse contenant lesdites données de recherches spécifiées à partir dudit module de régulation du système fichier afin de les retourner par transmission sur ledit réseau.
5. Dispositif selon la revendication 4, dans lequel ledit module de régulation du système fichier retourne directement lesdites données de recherches spécifiées vers ledit module de régulation du réseau.
- 20 6. Dispositif selon la revendication 4 ou 5, dans lequel ladite interface réseau est en outre couplée pour recevoir lesdites demandes de stockage réseau à partir dudit réseau,
- 25 dans lequel ledit module de régulation du réseau prépare en outre des demandes locales de stockage en réponse auxdites demandes de stockage réseau, afin de stocker des données spécifiées de stockage dans ledit dispositif de stockage de masse, ledit module de régulation du réseau communiquant lesdites demandes locales de stockage audit module de régulation du système fichier,
 - 30 et dans lequel ledit module de régulation du système fichier stocke en outre lesdites données spécifiées de stockage dans ledit dispositif de stockage de masse en réponse auxdites demandes locales de stockage.
7. Dispositif selon la revendication 6, dans lequel lesdites demandes locales de stockage sont communiquées audit module de régulation du système fichier via ledit chemin de communication (120).
- 35 8. Dispositif selon l'une des revendications précédentes, dans lequel ladite unité à processeur hôte exécute un système d'exploitation général, et dans lequel ladite unité d'interface à processeur n'exécute aucun système d'exploitation général.
9. Dispositif selon la revendication 8, dans lequel ledit système d'exploitation général est exécuté sur ladite unité à processeur hôte est un système d'exploitation UNIX.
- 40 10. Dispositif selon l'une des revendications précédentes, dans lequel ladite unité d'interface à processeur comprend des moyens (214, 314, 514) destinés à décoder toutes les demandes pour systèmes de fichier réseau (NFS) adressées à ladite unité d'interface à processeur à partir dudit réseau, destinés à mener toutes les procédures pour satisfaire lesdites demandes pour NFS, et destinés à coder tous les messages de réponse pour NFS afin de les retourner par transmission sur ledit réseau.
- 45 11. Dispositif selon l'une des revendications précédentes, dans lequel lesdits messages transmis comprennent tous les appels provenant d'un client du réseau audit dispositif serveur de réseau qui sont compris dans un jeu prédéfini d'appels en procédure à distance.
- 50 12. Dispositif selon l'une des revendications précédentes, comprenant en outre des moyens dans ladite unité d'interface à processeur destinés à détecter des demandes à partir dudit réseau pour une adresse dudit dispositif serveur de réseau, destinés à préparer un paquet de réponse à une telle demande d'adresse, et destinés à transmettre ledit paquet de réponse à travers ledit réseau.
- 55 13. Dispositif selon l'une des revendication précédentes, destiné à être en outre utilisé avec un deuxième réseau de données (122b), ladite unité d'interface à processeur pouvant être en outre couplée audit deuxième réseau, com-

EP 0 490 973 B1

prenant en outre des moyens (210, 214, 230, 250, 234, 254) dans ladite unité d'interface à processeur destinés à détecter une demande à partir dudit premier réseau pour acheminer un message contenu dans certains paquets vers une destination pouvant être atteinte à travers ledit deuxième réseau, et des moyens destinés à transmettre ledit message à travers ledit deuxième réseau.

5

10

15

20

25

30

35

40

45

50

55

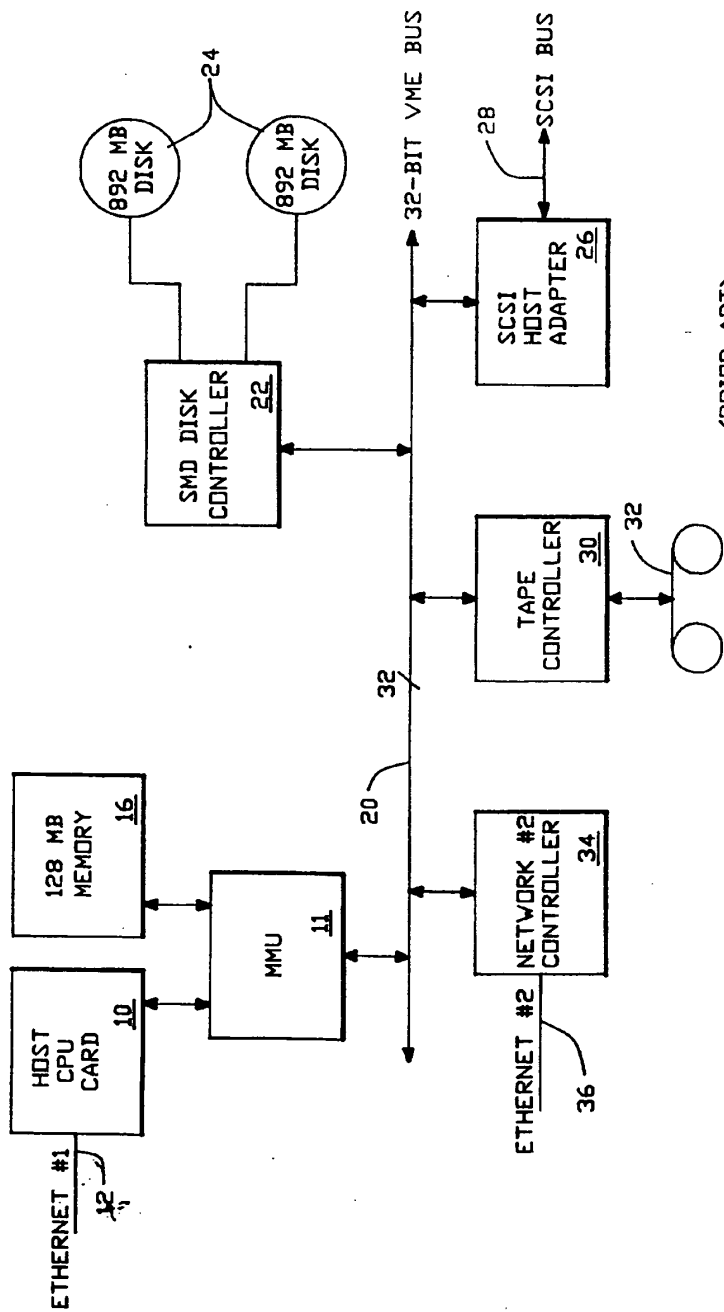

(PRIOR ART)

FIG.-1

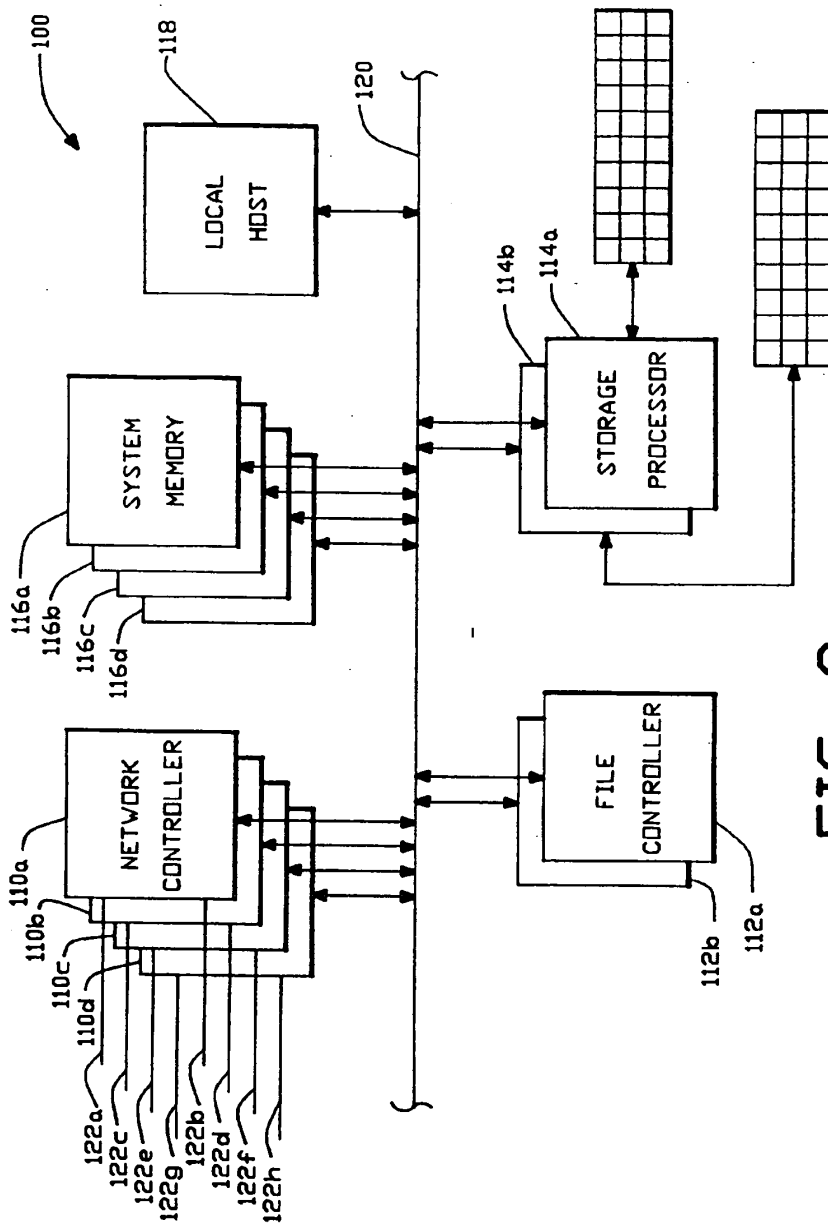

FIG.-2

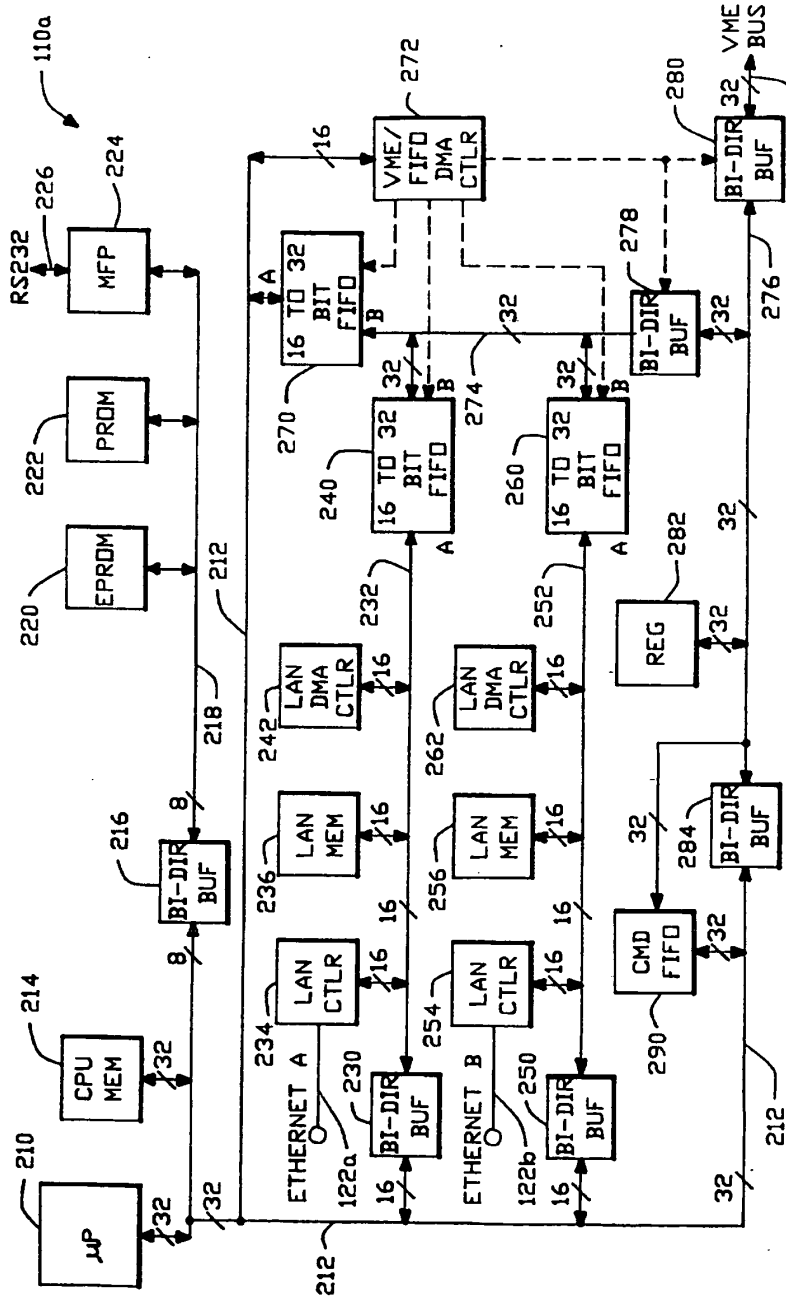

FIG. 3 (NETWORK CONTROLLER)

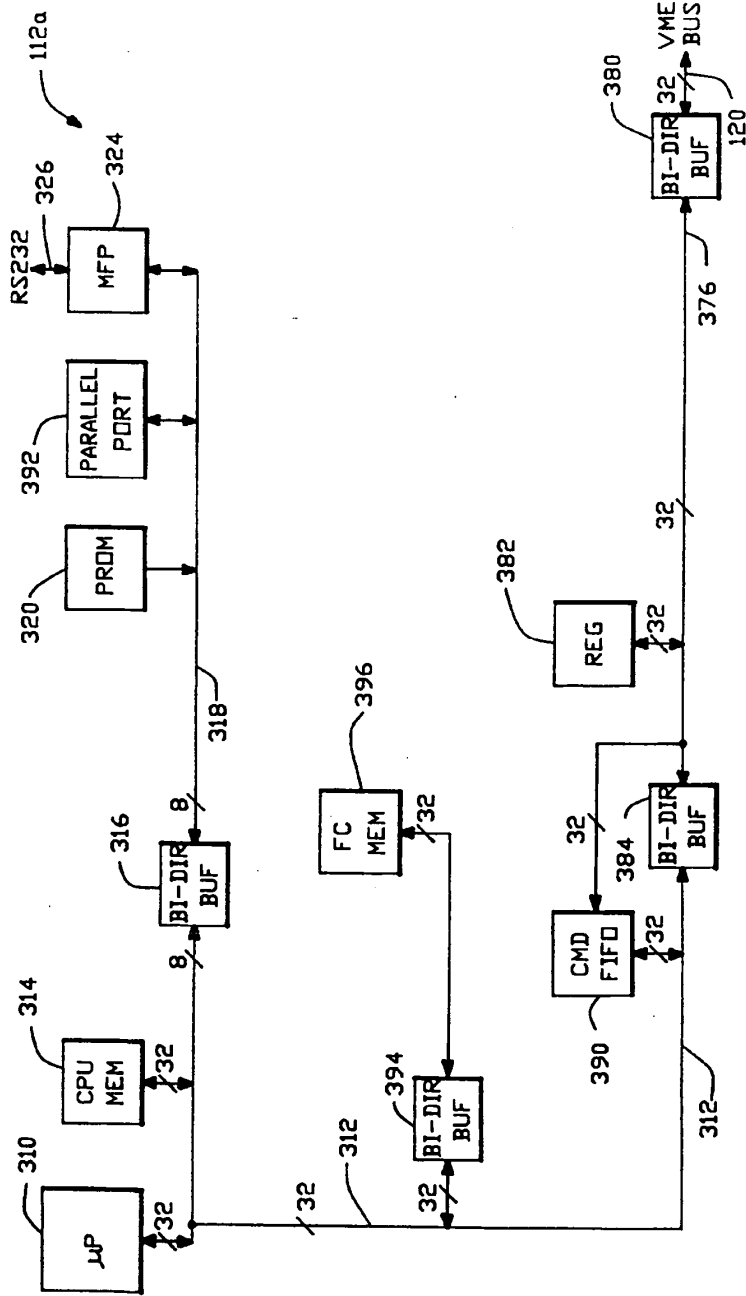

FIG.-4
(FILE CONTROLLER)

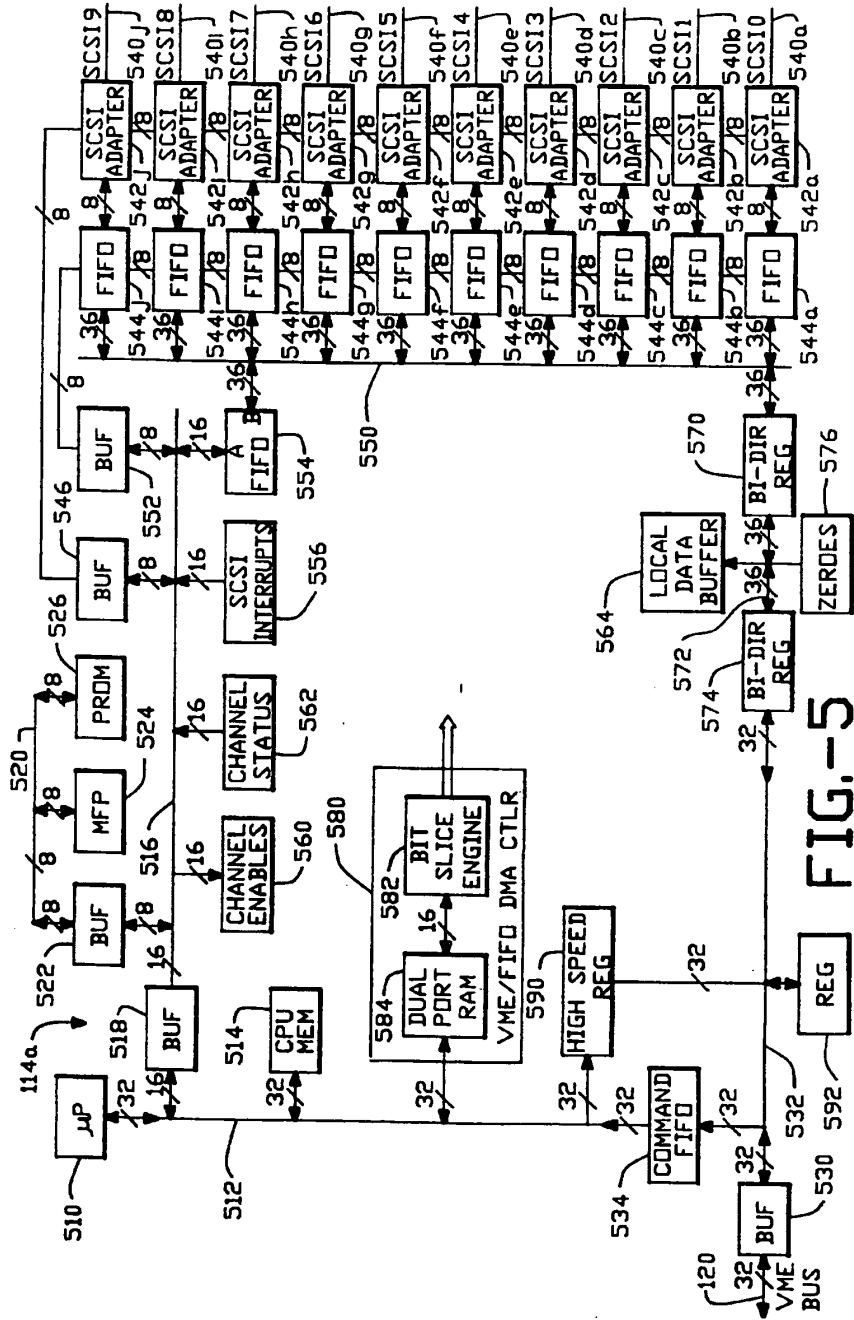

FIG. 5

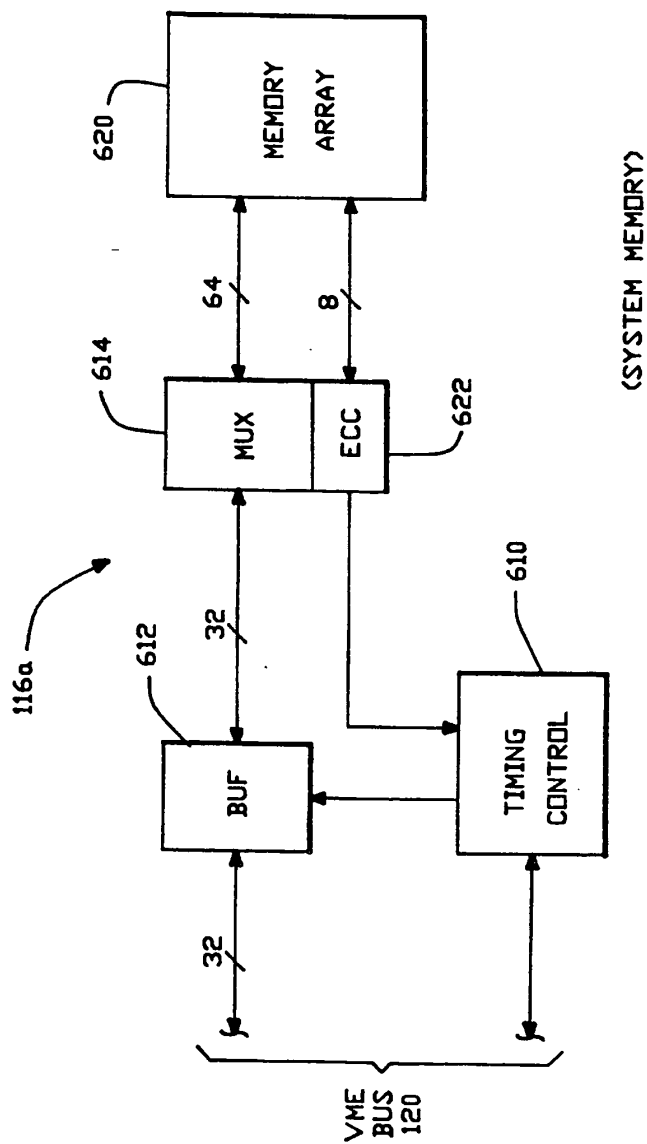

FIG.-6

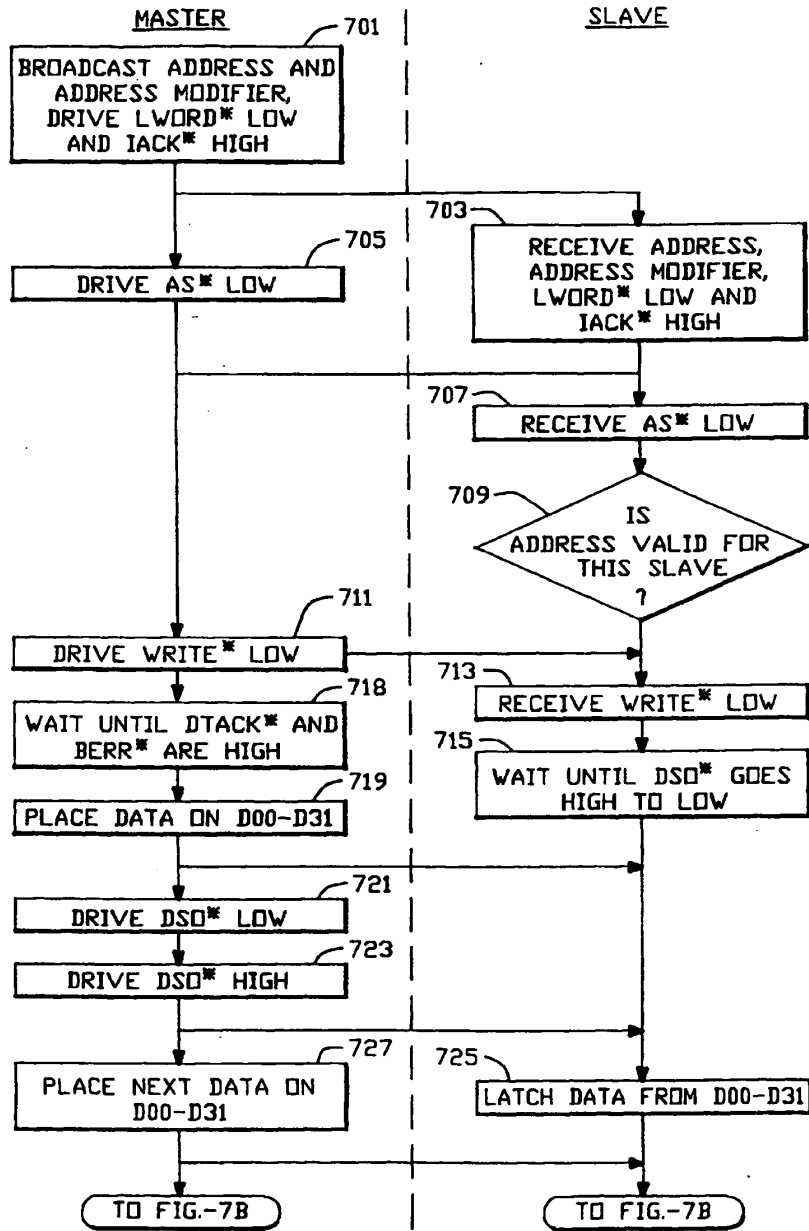

FIG.-7A

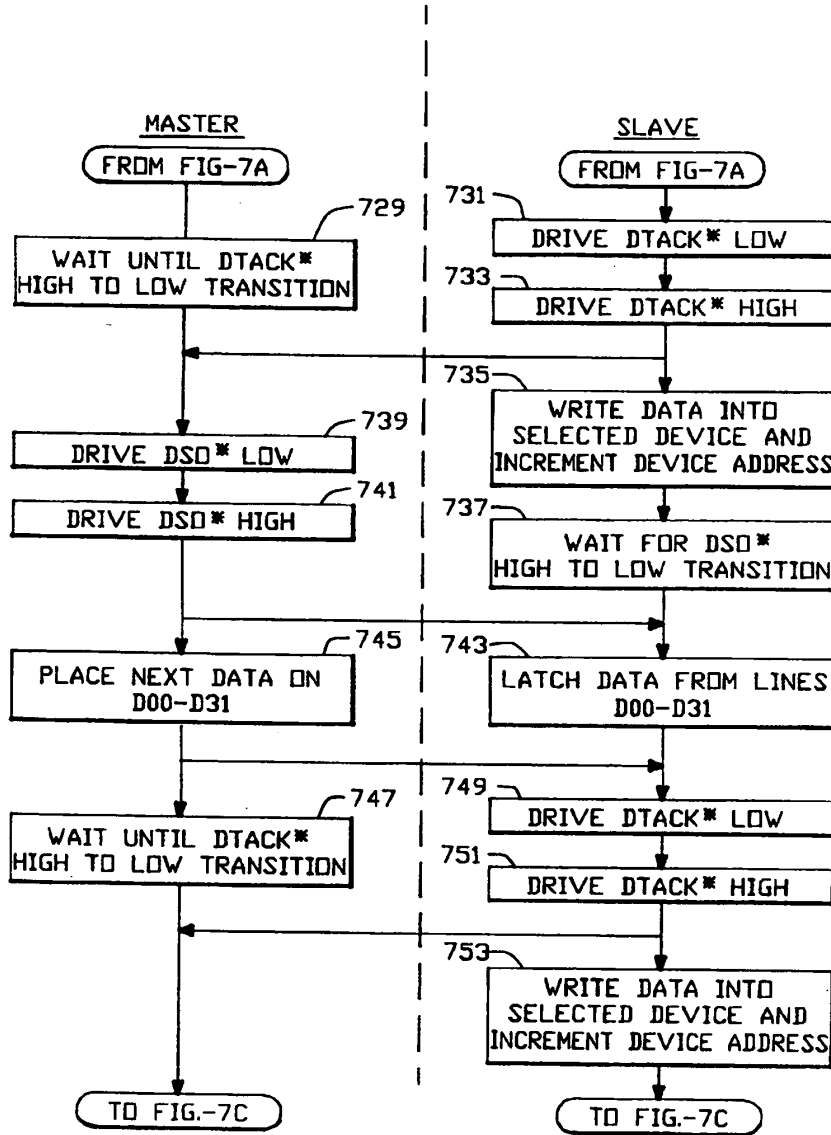

FIG.-7B

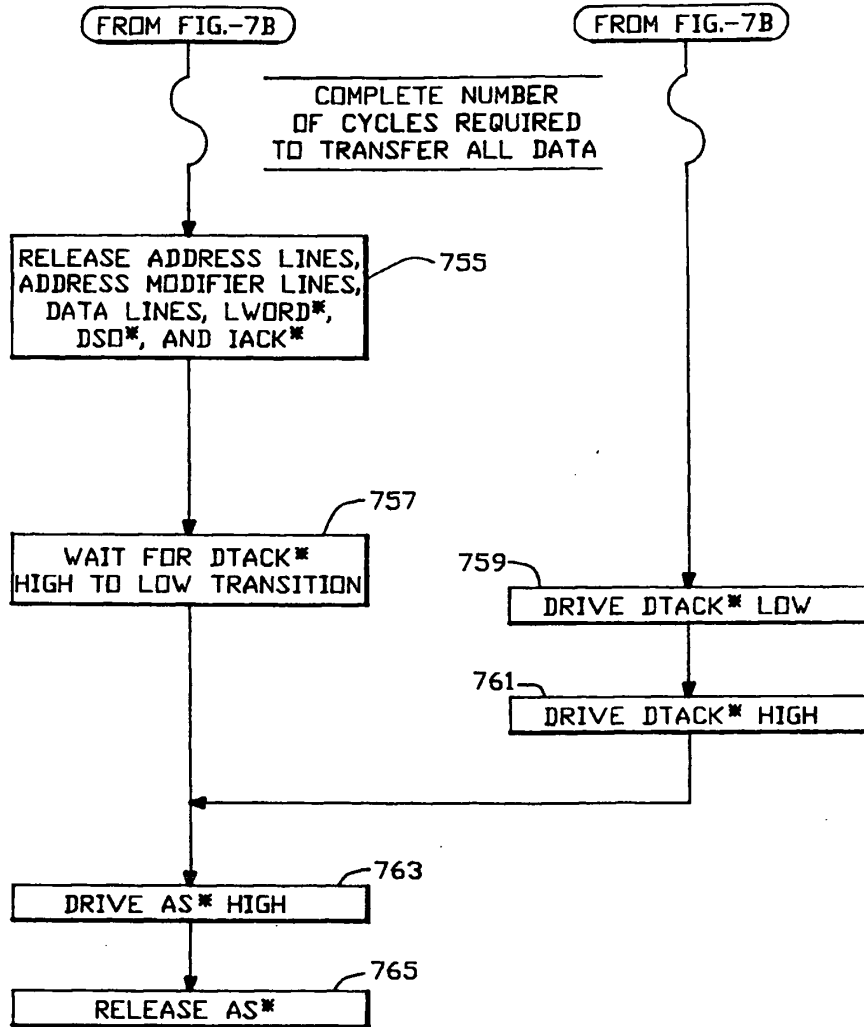

FIG.-7C

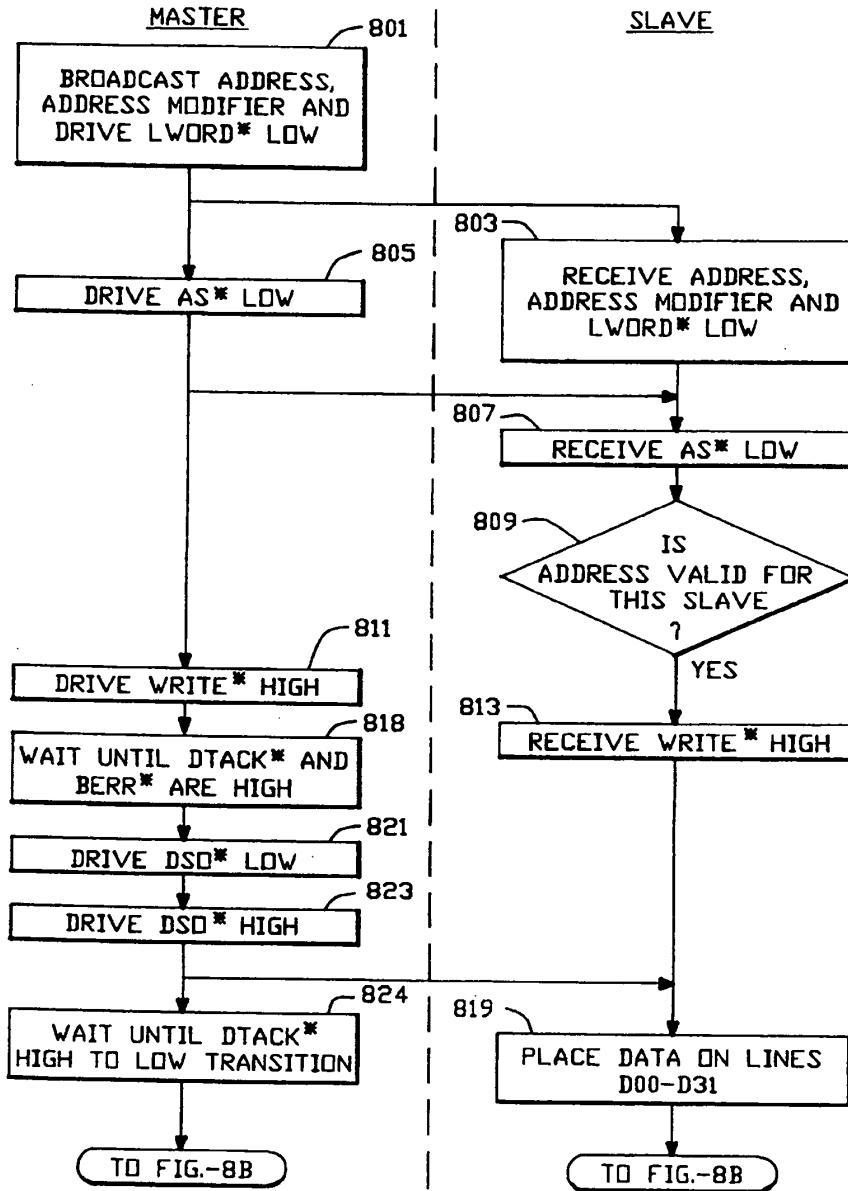

FIG.-8A

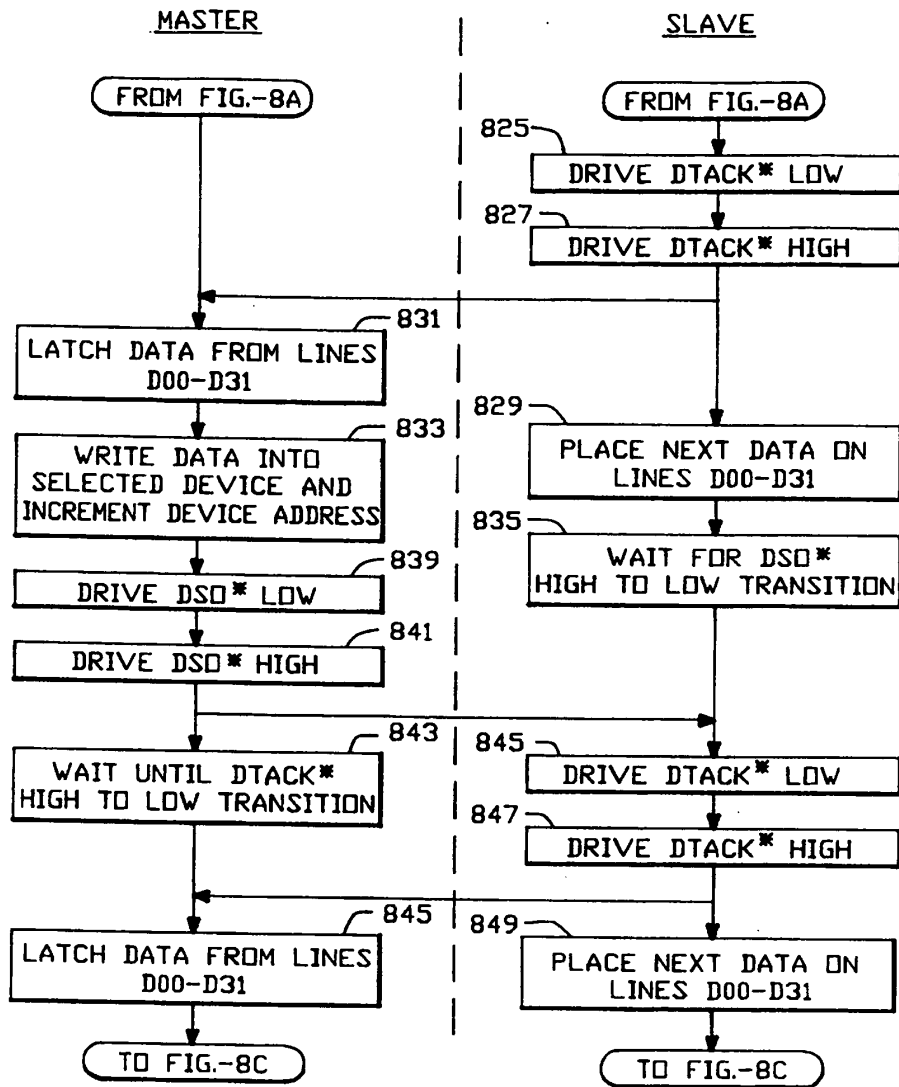

FIG.-8B

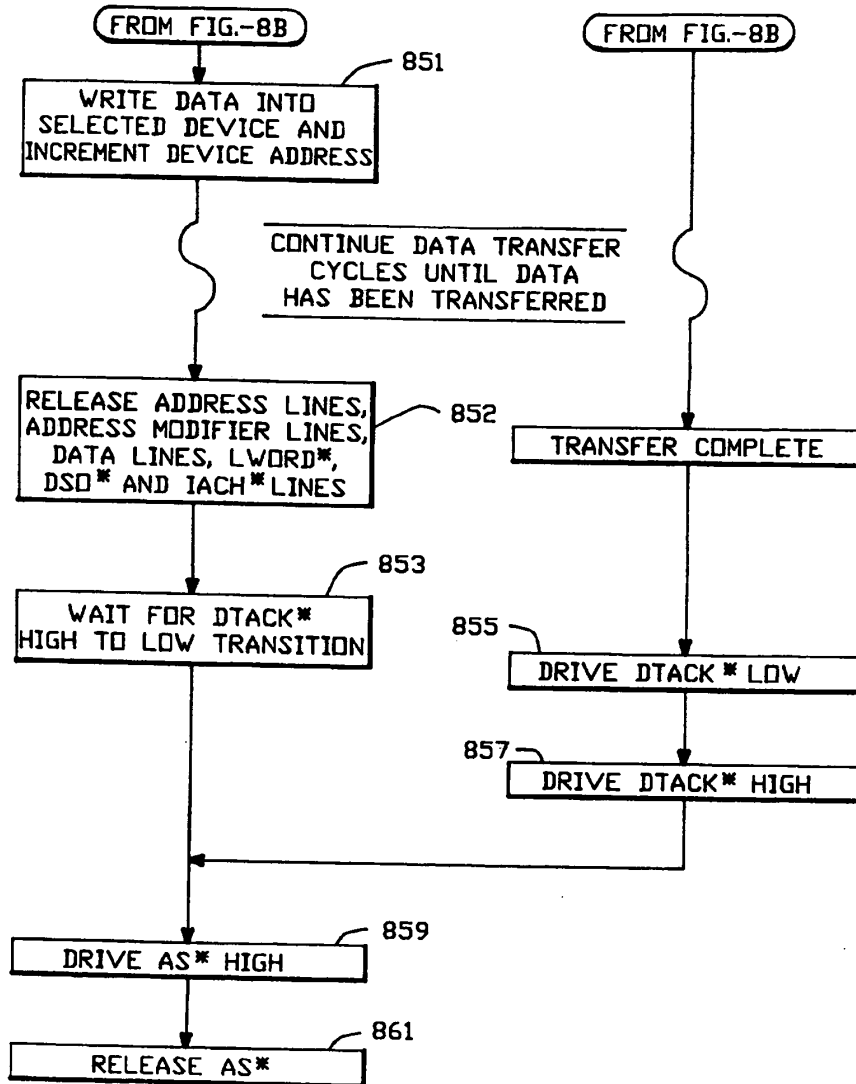

FIG.-8C

לשימוש הלשכה
For Office Use

095447	מספר: Number
21-08-1993	תאריך: Date
הוקדם/נודח Ante/Post-dated	

C: 11071

חוק הפטנטים תשכ"ז - 1967
PATENT LAW, 5727 - 1967

בקשה לפטנט
Application for Patent

B370
14

אני (שם המבקש, פענו ולבני גוף מאוגד - מקום התאגדותו)
(Name and address of applicant, and in case of body corporate-place of incorporation)

AUSPEX SYSTEMS, INC.,
2952 Bunker Hill Lane,
Santa Clara,
Ca. 95054, U.S.A.

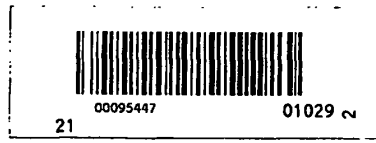

(Incorporated in the State of California, USA)

בעל אמצאה מכח
Owner, by virtue of

אריכטקטורה מקבילה למערכת שירות חקיקים
(בעברית)
(Hebrew)

PARALLEL I/O NETWORK FILE SERVER ARCHITECTURE
(באנגלית)
(English)

hereby apply for a patent to be granted to me in respect thereof.
מבקש בואת כי נתון לי עליה טענת

* בקשת חלוקה * Application of Division		* בקשת טענת מוסף * Application for Patent Addition		* דרישה רצף קדימה * Priority Claim		
מבקשת טענת from Application No. _____ מס' _____ dated _____ פיוס _____		* לבקשה/לפטנט * to Patent/Appl. No. _____ מס' _____ dated _____ פיוס _____		מספר/סימן Number/Mark 07/ 404,959	תאריך Date 8.9.89	מדינת האגוד Convention Country U.S.A.
* יגיש כח: כללי / מיוחד - רצוף בה / עזר יוגש * P.O.A.: general/individual-attached/to be filed later. הוגש בענין: _____ הען למצרה מסמכים ישראל Address for Service in Israel סנפורד ט. קולב & Co. Sanford T. Colb & Co. P.O.B. 2273 2273 ת.ח. Rehovot 76 122 רחובות 76122						
חתימת המבקש Signature of Applicant For the Applicant, Sanford T. Colb & Co. C: 11071				היום 20 כחדש VIII שנת 1990 of the year of This		
לשימוש הלשכה For Office Use						

תאריך הפרסום: 30-05-1994
Publication date: _____
תאריך פתיחתם: _____
Filing date: _____

טעם זה כשרוא מוטבע בותחם לשכת הפטנטים ומושלם במסר ובתאריך ההגשה, הנו אישור להגשת הבקשה שפרטיה רשומים לעיל.
This from, impressed with the Seal of the Patent Office and indicating the number and date of filing, certifies the filing of the application the particulars of which are set out above.

סלק את המיותר * Delete whatever is inapplicable *

אריכטקטורה מקבילה למערכת שירות תיקים

PARALLEL I/O NETWORK FILE SERVER ARCHITECTURE

AUSPEX SYSTEMS, INC.
C: 11071

BACKGROUND OF THE INVENTION

Field of the Invention

25 The invention relates to computer data networks,
and more particularly, to network file server
architectures for computer networks.

Description of the Related Art

Over the past ten years, remarkable increases in hardware price/performance ratios have caused a startling shift in both technical and office computing environments. Distributed workstation-server networks are displacing the once pervasive dumb terminal attached to mainframe or minicomputer. To date, however, network I/O limitations have constrained the potential performance available to workstation users. This situation has developed in part because dramatic jumps in microprocessor performance have exceeded increases in network I/O performance.

In a computer network, individual user workstations are referred to as clients, and shared resources for filing, printing, data storage and wide-area communications are referred to as servers. Clients and servers are all considered nodes of a network. Client nodes use standard communications protocols to exchange service requests and responses with server nodes.

Present-day network clients and servers usually run the DOS, MacIntosh OS, OS/2, or Unix operating systems. Local networks are usually Ethernet or Token Ring at the high end, Arcnet in the midrange, or LocalTalk or StarLAN at the low end. The client-server

communication protocols are fairly strictly dictated by the operating system environment -- usually one of several proprietary schemes for PCs (NetWare, 3Plus, Vines, LANManager, LANServer); AppleTalk for
5 MacIntoshes; and TCP/IP with NFS or RFS for Unix. These protocols are all well-known in the industry.

Unix client nodes typically feature a 16- or 32-bit microprocessor with 1-8 MB of primary memory, a 640 x 1024 pixel display, and a built-in network
10 interface. A 40-100 MB local disk is often optional. Low-end examples are 80286-based PCs or 68000-based MacIntosh I's; mid-range machines include 80386 PCs, MacIntosh II's, and 680X0-based Unix workstations; high-end machines include RISC-based DEC, HP, and Sun
15 Unix workstations. Servers are typically nothing more than repackaged client nodes, configured in 19-inch racks rather than desk sideboxes. The extra space of a 19-inch rack is used for additional backplane slots, disk or tape drives, and power supplies.

20 Driven by RISC and CISC microprocessor developments, client workstation performance has increased by more than a factor of ten in the last few years. Concurrently, these extremely fast clients have also gained an appetite for data that remote
25 servers are unable to satisfy. Because the I/O shortfall is most dramatic in the Unix environment, the

description of the preferred embodiment of the present invention will focus on Unix file servers. The architectural principles that solve the Unix server I/O problem, however, extend easily to server performance
5 bottlenecks in other operating system environments as well. Similarly, the description of the preferred embodiment will focus on Ethernet implementations, though the principles extend easily to other types of networks.

10 In most Unix environments, clients and servers exchange file data using the Network File System ("NFS"), a standard promulgated by Sun Microsystems and now widely adopted by the Unix community. NFS is defined in a document entitled, "NFS: Network File
15 System Protocol Specification," Request For Comments (RFC) 1094, by Sun Microsystems, Inc. (March 1989). This document is incorporated herein by reference in its entirety.

While simple and reliable, NFS is not optimal.
20 Clients using NFS place considerable demands upon both networks and NFS servers supplying clients with NFS data. This demand is particularly acute for so-called diskless clients that have no local disks and therefore depend on a file server for application
25 binaries and virtual memory paging as well as data. For these Unix client-server configurations, the ten-

to-one increase in client power has not been matched by a ten-to-one increase in Ethernet capacity, in disk speed, or server disk-to-network I/O throughput.

The result is that the number of diskless clients that a single modern high-end server can adequately support has dropped to between 5-10, depending on client power and application workload. For clients containing small local disks for applications and paging, referred to as dataless clients, the client-to-server ratio is about twice this, or between 10-20.

Such low client/server ratios cause piecewise network configurations in which each local Ethernet contains isolated traffic for its own 5-10 (diskless) clients and dedicated server. For overall connectivity, these local networks are usually joined together with an Ethernet backbone or, in the future, with an FDDI backbone. These backbones are typically connected to the local networks either by IP routers or MAC-level bridges, coupling the local networks together directly, or by a second server functioning as a network interface, coupling servers for all the local networks together.

In addition to performance considerations, the low client-to-server ratio creates computing problems in several additional ways:

1. Sharing. Development groups of more than 5-10 people cannot share the same server, and thus cannot easily share files without file replication and manual, multi-server updates. Bridges or routers are a partial solution but inflict a performance penalty due to more network hops.

2. Administration. System administrators must maintain many limited-capacity servers rather than a few more substantial servers. This burden includes network administration, hardware maintenance, and user account administration.

3. File System Backup. System administrators or operators must conduct multiple file system backups, which can be onerously time consuming tasks. It is also expensive to duplicate backup peripherals on each server (or every few servers if slower network backup is used).

4. Price Per Seat. With only 5-10 clients per server, the cost of the server must be shared by only a small number of users. The real cost of an entry-level Unix workstation is therefore significantly greater, often as much as 140% greater, than the cost of the workstation alone.

The widening I/O gap, as well as administrative and economic considerations, demonstrates a need for higher-performance, larger-capacity Unix file servers.

Conversion of a display-less workstation into a server may address disk capacity issues, but does nothing to address fundamental I/O limitations. As an NFS server, the one-time workstation must sustain 5-10 or more times the network, disk, backplane, and file system throughput than it was designed to support as a client. Adding larger disks, more network adaptors, extra primary memory, or even a faster processor do not resolve basic architectural I/O constraints; I/O throughput does not increase sufficiently.

Other prior art computer architectures, while not specifically designed as file servers, may potentially be used as such. In one such well-known architecture, a CPU, a memory unit, and two I/O processors are connected to a single bus. One of the I/O processors operates a set of disk drives, and if the architecture is to be used as a server, the other I/O processor would be connected to a network. This architecture is not optimal as a file server, however, at least because the two I/O processors cannot handle network file requests without involving the CPU. All network file requests that are received by the network I/O processor are first transmitted to the CPU, which makes appropriate requests to the disk-I/O processor for satisfaction of the network request.

In another such computer architecture, a disk controller CPU manages access to disk drives, and several other CPUs, three for example, may be clustered around the disk controller CPU. Each of the other CPUs can be connected to its own network. The network CPUs are each connected to the disk controller CPU as well as to each other for interprocessor communication. One of the disadvantages of this computer architecture is that each CPU in the system runs its own complete operating system. Thus, network file server requests must be handled by an operating system which is also heavily loaded with facilities and processes for performing a large number of other, non file-server tasks. Additionally, the interprocessor communication is not optimized for file server type requests.

In yet another computer architecture, a plurality of CPUs, each having its own cache memory for data and instruction storage, are connected to a common bus with a system memory and a disk controller. The disk controller and each of the CPUs have direct memory access to the system memory, and one or more of the CPUs can be connected to a network. This architecture is disadvantageous as a file server because, among other things, both file data and the instructions for the CPUs reside in the same system memory. There will

be instances, therefore, in which the CPUs must stop running while they wait for large blocks of file data to be transferred between system memory and the network CPU. Additionally, as with both of the previously
5 described computer architectures, the entire operating system runs on each of the CPUs, including the network CPU.

In yet another type of computer architecture, a large number of CPUs are connected together in a
10 hypercube topology. One or more of these CPUs can be connected to networks, while another can be connected to disk drives. This architecture is also disadvantageous as a file server because, among other things, each processor runs the entire operating
15 system. Interprocessor communication is also not optimal for file server applications.

SUMMARY OF THE INVENTION

The present invention involves a new, server-specific I/O architecture that is optimized for a Unix
20 file server's most common actions -- file operations. Roughly stated, the invention involves a file server architecture comprising one or more network controllers, one or more file controllers, one or more storage processors, and a system or buffer memory, all
25 connected over a message passing bus and operating in

Attorney Docket No.:AUSP7209
WP1/WSW/AUSP/7209.001

8/24/89-7

parallel with the Unix host processor. The network controllers each connect to one or more network, and provide all protocol processing between the network layer data format and an internal file server format for communicating client requests to other processors in the server. Only those data packets which cannot be interpreted by the network controllers, for example client requests to run a client-defined program on the server, are transmitted to the Unix host for processing. Thus the network controllers, file controllers and storage processors contain only small parts of an overall operating system, and each is optimized for the particular type of work to which it is dedicated.

Client requests for file operations are transmitted to one of the file controllers which, independently of the Unix host, manages the virtual file system of a mass storage device which is coupled to the storage processors. The file controllers may also control data buffering between the storage processors and the network controllers, through the system memory. The file controllers preferably each include a local buffer memory for caching file control information, separate from the system memory for caching file data. Additionally, the network controllers, file processors and storage processors are

all designed to avoid any instruction fetches from the system memory, instead keeping all instruction memory separate and local. This arrangement eliminates contention on the backplane between microprocessor instruction fetches and transmissions of message and file data.

BRIEF DESCRIPTION OF THE DRAWINGS

The invention will be described with respect to particular embodiments thereof, and reference will be made to the drawings, in which:

Fig. 1. is a block diagram of a prior art file server architecture;

Fig. 2 is a block diagram of a file server architecture according to the invention;

Fig. 3 is a block diagram of one of the network controllers shown in Fig. 2;

Fig. 4 is a block diagram of one of the file controllers shown in Fig. 2;

Fig. 5 is a block diagram of one of the storage processors shown in Fig. 2;

Fig. 6 is a block diagram of one of the system memory cards shown in Fig. 2;

Figs. 7A-C are a flowchart illustrating the operation of a fast transfer protocol BLOCK WRITE cycle; and

Figs. 8A-C are a flowchart illustrating the operation of a fast transfer protocol BLOCK READ cycle.

DETAILED DESCRIPTION

5 For comparison purposes and background, an illustrative prior-art file server architecture will first be described with respect to Fig. 1. Fig. 1 is an overall block diagram of a conventional prior-art Unix-based file server for Ethernet networks. It
10 consists of a host CPU card 10 with a single microprocessor on board. The host CPU card 10 connects to an Ethernet #1 12, and it connects via a memory management unit (MMU) 11 to a large memory array 16. The host CPU card 10 also drives a keyboard, a video
15 display, and two RS232 ports (not shown). It also connects via the MMU 11 and a standard 32-bit VME bus 20 to various peripheral devices, including an SMD disk controller 22 controlling one or two disk drives 24, a SCSI host adaptor 26 connected to a SCSI bus 28, a
20 tape controller 30 connected to a quarter-inch tape drive 32, and possibly a network #2 controller 34 connected to a second Ethernet 36. The SMD disk controller 22 can communicate with memory array 16 by direct memory access via bus 20 and MMU 11, with either
25 the disk controller or the MMU acting as a bus master.

This configuration is illustrative; many variations are available.

The system communicates over the Ethernets using industry standard TCP/IP and NFS protocol stacks. A description of protocol stacks in general can be found in Tanenbaum, "Computer Networks" (Second Edition, Prentice Hall: 1988). File server protocol stacks are described at pages 535-546. The Tanenbaum reference is incorporated herein by reference.

Basically, the following protocol layers are implemented in the apparatus of Fig. 1:

Network Layer. The network layer converts data packets between a format specific to Ethernets and a format which is independent of the particular type of network used. the Ethernet-specific format which is used in the apparatus of Fig. 1 is described in Hornig, "A Standard For The Transmission of IP Datagrams Over Ethernet Networks," RFC 894 (April 1984), which is incorporated herein by reference.

The Internet Protocol (IP) Layer. This layer provides the functions necessary to deliver a package of bits (an internet datagram) from a source to a destination over an interconnected system of networks. For messages to be sent from the file server to a client, a higher level in the server calls the IP module, providing the internet address of the

destination client and the message to transmit. The IP module performs any required fragmentation of the message to accommodate packet size limitations of any intervening gateway, adds internet headers to each
5 fragment, and calls on the network layer to transmit the resulting internet datagrams. The internet header includes a local network destination address (translated from the internet address) as well as other parameters.

10 For messages received by the IP layer from the network layer, the IP module determines from the internet address whether the datagram is to be forwarded to another host on another network, for example on a second Ethernet such as 36 in Fig. 1, or
15 whether it is intended for the server itself. If it is intended for another host on the second network, the IP module determines a local net address for the destination and calls on the local network layer for that network to send the datagram. If the datagram is
20 intended for an application program within the server, the IP layer strips off the header and passes the remaining portion of the message to the appropriate next higher layer. The internet protocol standard used in the illustrative apparatus of Fig. 1 is specified in
25 Information Sciences Institute, "Internet Protocol, DARPA Internet Program Protocol Specification," RFC 791

(September 1981), which is incorporated herein by reference.

TCP/UDP Layer. This layer is a datagram service with more elaborate packaging and addressing options than the IP layer. For example, whereas an IP datagram can hold about 1,500 bytes and be addressed to hosts, UDP datagrams can hold about 64KB and be addressed to a particular port within a host. TCP and UDP are alternative protocols at this layer; applications requiring ordered reliable delivery of streams of data may use TCP, whereas applications (such as NFS) which do not require ordered and reliable delivery may use UDP.

The prior art file server of Fig. 1 uses both TCP and UDP. It uses UDP for file server-related services, and uses TCP for certain other services which the server provides to network clients. The UDP is specified in Postel, "User Datagram Protocol," RFC 768 (August 28, 1980), which is incorporated herein by reference. TCP is specified in Postel, "Transmission Control Protocol," RFC 761 (January 1980) and RFC 793 (September 1981), which is also incorporated herein by reference.

XDR/RPC Layer. This layer provides functions callable from higher level programs to run a designated procedure on a remote machine. It also provides the

decoding necessary to permit a client machine to execute a procedure on the server. For example, a caller process in a client node may send a call message to the server of Fig. 1. The call message includes a specification of the desired procedure, and its parameters. The message is passed up the stack to the RPC layer, which calls the appropriate procedure within the server. When the procedure is complete, a reply message is generated and RPC passes it back down the stack and over the network to the caller client. RPC is described in Sun Microsystems, Inc., "RPC: Remote Procedure Call Protocol Specification, Version 2," RFC 1057 (June 1988); which is incorporated herein by reference.

RPC uses the XDR external data representation standard to represent information passed to and from the underlying UDP layer. XDR is merely a data encoding standard, useful for transferring data between different computer architectures. Thus, on the network side of the XDR/RPC layer, information is machine-independent; on the host application side, it may not be. XDR is described in Sun Microsystems, Inc., "XDR: External Data Representation Standard," RFC 1014 (June 1987), which is incorporated herein by reference.

NFS Layer. The NFS ("network file system") layer is one of the programs available on the server

which an RPC request can call. The combination of host address, program number, and procedure number in an RPC request can specify one remote NFS procedure to be called.

5 Remote procedure calls to NFS on the file server of Fig. 1 provide transparent, stateless, remote access to shared files on the disks 24. NFS assumes a file system that is hierarchical, with directories as all but the bottom level of files. Client hosts can call
10 any of about 20 NFS procedures including such procedures as reading a specified number of bytes from a specified file; writing a specified number of bytes to a specified file; creating, renaming and removing specified files; parsing directory trees; creating and
15 removing directories; and reading and setting file attributes. The location on disk to which and from which data is stored and retrieved is always specified in logical terms, such as by a file handle or Inode designation and a byte offset. The details of the
20 actual data storage are hidden from the client. The NFS procedures, together with possible higher level modules such as Unix VFS and UFS, perform all conversion of logical data addresses to physical data addresses such as drive, head, track and sector
25 identification. NFS is specified in Sun Microsystems, Inc., "NFS: Network File System Protocol

Specification," RFC 1094 (March 1989), incorporated herein by reference.

5 With the possible exception of the network layer, all the protocol processing described above is done in software, by a single processor in the host CPU card 10. That is, when an Ethernet packet arrives on Ethernet 12, the host CPU 10 performs all the protocol processing in the NFS stack, as well as the protocol processing for any other application which may be 10 running on the host 10. NFS procedures are run on the host CPU 10, with access to memory 16 for both data and program code being provided via MMU 11. Logically specified data addresses are converted to a much more physically specified form and communicated to the SMD 15 disk controller 22 or the SCSI bus 28, via the VME bus 20, and all disk caching is done by the host CPU 10 through the memory 16. The host CPU card 10 also runs procedures for performing various other functions of the file server, communicating with tape controller 30 20 via the VME bus 20. Among these are client-defined remote procedures requested by client workstations.

If the server serves a second Ethernet 36, packets from that Ethernet are transmitted to the host CPU 10 over the same VME bus 20 in the form of IP datagrams. 25 Again, all protocol processing except for the network layer is performed by software processes running on the

host CPU 10. In addition, the protocol processing for any message that is to be sent from the server out on either of the Ethernets 12 or 36 is also done by processes running on the host CPU 10.

5 It can be seen that the host CPU 10 performs an enormous amount of processing of data, especially if 5-10 clients on each of the two Ethernets are making file server requests and need to be sent responses on a frequent basis. The host CPU 10 runs a multitasking
10 Unix operating system, so each incoming request need not wait for the previous request to be completely processed and returned before being processed. Multiple processes are activated on the host CPU 10 for performing different stages of the processing of
15 different requests, so many requests may be in process at the same time. But there is only one CPU on the card 10, so the processing of these requests is not accomplished in a truly parallel manner. The processes are instead merely time sliced. The CPU 10 therefore
20 represents a major bottleneck in the processing of file server requests.

 Another bottleneck occurs in MMU 11, which must transmit both instructions and data between the CPU card 10 and the memory 16. All data flowing between
25 the disk drives and the network passes through this interface at least twice.

Yet another bottleneck can occur on the VME bus 20, which must transmit data among the SMD disk controller 22, the SCSI host adaptor 26, the host CPU card 10, and possibly the network #2 controller 34.

5 PREFERRED EMBODIMENT-OVERALL HARDWARE ARCHITECTURE

In Fig. 2 there is shown a block diagram of a network file server 100 according to the invention. It can include multiple network controller (NC) boards, one or more file controller (FC) boards, one or more storage processor (SP) boards, multiple system memory boards, and one or more host processors. The particular embodiment shown in Fig. 2 includes four network controller boards 110a-110d, two file controller boards 112a-112b, two storage processors 15 114a-114b, four system memory cards 116a-116d for a total of 192MB of memory, and one local host processor 118. The boards 110, 112, 114, 116 and 118 are connected together over a VME bus 120 on which an enhanced block transfer mode as described in the 20 ENHANCED VMEBUS PROTOCOL application identified above may be used. Each of the four network controllers 110 shown in Fig. 2 can be connected to up to two Ethernets 122, for a total capacity of 8 Ethernets 122a-122h. Each of the storage processors 114 operates ten 25 parallel SCSI busses, nine of which can each support up

to three SCSI disk drives each. The tenth SCSI channel on each of the storage processors 114 is used for tape drives and other SCSI peripherals.

The host 118 is essentially a standard SunOs Unix processor, providing all the standard Sun Open Network Computing (ONC) services except NFS and IP routing. Importantly, all network requests to run a user-defined procedure are passed to the host for execution. Each of the NC boards 110, the FC boards 112 and the SP boards 114 includes its own independent 32-bit microprocessor. These boards essentially off-load from the host processor 118 virtually all of the NFS and disk processing. Since the vast majority of messages to and from clients over the Ethernets 122 involve NFS requests and responses, the processing of these requests in parallel by the NC, FC and SP processors, with minimal involvement by the local host 118, vastly improves file server performance. Unix is explicitly eliminated from virtually all network, file, and storage processing.

OVERALL SOFTWARE ORGANIZATION AND DATA FLOW

Prior to a detailed discussion of the hardware subsystems shown in Fig. 2, an overview of the software structure will now be undertaken. The software organization is described in more detail in the above-

identified application entitled MULTIPLE FACILITY
OPERATING SYSTEM ARCHITECTURE.

Most of the elements of the software are well
known in the field and are found in most networked Unix
5 systems, but there are two components which are not:
Local NFS ("LNFS") and the messaging kernel ("MK")
operating system kernel. These two components will be
explained first.

The Messaging Kernel. The various processors in
10 file server 100 communicate with each other through the
use of a messaging kernel running on each of the
processors 110, 112, 114 and 118. These processors do
not share any instruction memory, so task-level
communication cannot occur via straightforward
15 procedure calls as it does in conventional Unix.
Instead, the messaging kernel passes messages over VME
bus 120 to accomplish all necessary inter-processor
communication. Message passing is preferred over
remote procedure calls for reasons of simplicity and
20 speed.

Messages passed by the messaging kernel have a
fixed 128-byte length. Within a single processor,
messages are sent by reference; between processors,
they are copied by the messaging kernel and then
25 delivered to the destination process by reference. The
processors of Fig. 2 have special hardware, discussed

below, that can expediently exchange and buffer inter-processor messaging kernel messages.

The LNFS Local NFS interface. The 22-function NFS standard was specifically designed for stateless operation using unreliable communication. This means that neither clients nor server can be sure if they hear each other when they talk (unreliability). In practice, in an Ethernet environment, this works well.

10 Within the server 100, however, NFS level datagrams are also used for communication between processors, in particular between the network controllers 110 and the file controller 112, and between the host processor 118 and the file controller
15 112. For this internal communication to be both efficient and convenient, it is undesirable and impractical to have complete statelessness or unreliable communications. Consequently, a modified form of NFS, namely LNFS, is used for internal
20 communication of NFS requests and responses. LNFS is used only within the file server 100; the external network protocol supported by the server is precisely standard, licensed NFS. LNFS is described in more detail below.

25 The Network Controllers 110 each run an NFS server which, after all protocol processing is done up to the

NFS layer, converts between external NFS requests and responses and internal LNFS requests and responses. For example, NFS requests arrive as RPC requests with XDR and enclosed in a UDP datagram. After protocol
5 processing, the NFS server translates the NFS request into LNFS form and uses the messaging kernel to send the request to the file controller 112.

The file controller runs an LNFS server which handles LNFS requests both from network controllers and
10 from the host 118. The LNFS server translates LNFS requests to a form appropriate for a file system server, also running on the file controller, which manages the system memory file data cache through a block I/O layer.

15 An overview of the software in each of the processors will now be set forth.

Network Controller 110

The optimized dataflow of the server 100 begins with the intelligent network controller 110. This
20 processor receives Ethernet packets from client workstations. It quickly identifies NFS-destined packets and then performs full protocol processing on them to the NFS level, passing the resulting LNFS requests directly to the file controller 112. This
25 protocol processing includes IP routing and reassembly;

Attorney Docket No.:AUSP7209
WP1/WSW/AUSP/7209.001

8/24/89-7

UDP demultiplexing, XDR decoding, and NFS request
dispatching. The reverse steps are used to send an NFS
reply back to a client. Importantly, these time-
consuming activities are performed directly in the
5 Network Controller 110, not in the host 118.

The server 100 uses conventional NFS ported from
Sun Microsystems, Inc., Mountain View, CA, and is NFS
protocol compatible.

10 Non-NFS network traffic is passed directly to its
destination host processor 118.

The NCs 110 also perform their own IP routing.
Each network controller 110 supports two fully parallel
Ethernets. There are four network controllers in the
embodiment of the server 100 shown in Fig. 2, so that
15 server can support up to eight Ethernets. For the two
Ethernets on the same network controller 110, IP
routing occurs completely within the network
controller and generates no backplane traffic. Thus
attaching two mutually active Ethernets to the same
20 controller not only minimizes their inter-net transit
time, but also significantly reduces backplane
contention on the VME bus 120. Routing table updates
are distributed to the network controllers from the
host processor 118, which runs either the gated or
25 routed Unix demon.

While the network controller described here is designed for Ethernet LANs, it will be understood that the invention can be used just as readily with other network types, including FDDI.

5 File Controller 112

In addition to dedicating a separate processor for NFS protocol processing and IP routing, the server 100 also dedicates a separate processor, the intelligent file controller 112, to be responsible for all file system processing. It uses conventional Berkeley Unix 10 4.3 file system code and uses a binary-compatible data representation on disk. These two choices allow all standard file system utilities (particularly block-level tools) to run unchanged.

15 The file controller 112 runs the shared file system used by all NCs 110 and the host processor 118. Both the NCs and the host processor communicate with the file controller 112 using the LNFS interface. The NCs 110 use LNFS as described above, while the host 20 processor 118 uses LNFS as a plug-in module to SunOs's standard Virtual File System ("VFS") interface.

When an NC receives an NFS read request from a client workstation, the resulting LNFS request passes to the FC 112. The FC 112 first searches the system 25 memory 116 buffer cache for the requested data. If

found, a reference to the buffer is returned to the NC 110. If not found, the LRU (least recently used) cache buffer in system memory 116 is freed and reassigned for the requested block. The FC then directs the SP 114 to
5 read the block into the cache buffer from a disk drive array. When complete, the SP so notifies the FC, which in turn notifies the NC 110. The NC 110 then sends an NFS reply, with the data from the buffer, back to the NFS client workstation out on the network. Note that
10 the SP 114 transfers the data into system memory 116, if necessary, and the NC 110 transfers the data from system memory 116 to the networks. The process takes place without any involvement of the host 118.

Storage Processor

15 The intelligent storage processor 114 manages all disk and tape storage operations. While autonomous, storage processors are primarily directed by the file controller 112 to move file data between system memory 116 and the disk subsystem. The exclusion of both the
20 host 118 and the FC 112 from the actual data path helps to supply the performance needed to service many remote clients.

Additionally, coordinated by a Server Manager in the host 118, storage processor 114 can execute server
25 backup by moving data between the disk subsystem and

tape or other archival peripherals on the SCSI channels. Further, if directly accessed by host processor 118, SP 114 can provide a much higher performance conventional disk interface for Unix, virtual memory, and databases. In Unix nomenclature, the host processor 118 can mount boot, storage swap, and raw partitions via the storage processors 114.

Each storage processor 114 operates ten parallel, fully synchronous SCSI channels (busses) simultaneously. Nine of these channels support three arrays of nine SCSI disk drives each, each drive in an array being assigned to a different SCSI channel. The tenth SCSI channel hosts up to seven tape and other SCSI peripherals. In addition to performing reads and writes, SP 114 performs device-level optimizations such as disk seek queue sorting, directs device error recovery, and controls DMA transfers between the devices and system memory 116.

Host Processor 118

The local host 118 has three main purposes: to run Unix, to provide standard ONC network services for clients, and to run a Server Manager. Since Unix and ONC are ported from the standard SunOs Release 4 and ONC Services Release 2, the server 100 can provide identically compatible high-level ONC services such as

the Yellow Pages, Lock Manager, DES Key Authenticator, Auto Mounter, and Port Mapper. Sun/2 Network disk booting and more general IP internet services such as Telnet, FTP, SMTP, SNMP, and reverse ARP are also supported. Finally, print spoolers and similar Unix demons operate transparently.

The host processor 118 runs the following software modules:

TCP and socket layers. The Transport Control Protocol ("TCP"), which is used for certain server functions other than NFS, provides reliable bytestream communication between two processors. Sockets are used to establish TCP connections.

VFS interface. The Virtual File System ("VFS") interface is a standard SunOs file system interface. It paints a uniform file-system picture for both users and the non-file parts of the Unix operating system, hiding the details of the specific file system. Thus standard NFS, LNFS, and any local Unix file system can coexist harmoniously.

UFS interface. The Unix File System ("UFS") interface is the traditional and well-known Unix interface for communication with local-to-the-processor disk drives. In the server 100, it is used to occasionally mount storage processor volumes directly, without going through the file controller 112.

Attorney Docket No.:AUSP7209
WP1/WSW/AUSP/7209.001

8/24/89-7

Normally, the host 118 uses LNFS and goes through the file controller.

5 Device layer. The device layer is a standard software interface between the Unix device model and different physical device implementations. In the server 100, disk devices are not attached to host processors directly, so the disk driver in the host's device layer uses the messaging kernel to communicate with the storage processor 114.

10 Route and Port Mapper Demons. The Route and Port Mapper demons are Unix user-level background processes that maintain the Route and Port databases for packet routing. They are mostly inactive and not in any performance path.

15 Yellow Pages and Authentication Demon. The Yellow Pages and Authentication services are Sun-ONC standard network services. Yellow Pages is a widely used multipurpose name-to-name directory lookup service. The Authentication service uses cryptographic keys to
20 authenticate, or validate, requests to insure that requestors have the proper privileges for any actions or data they desire.

25 Server Manager. The Server Manager is an administrative application suite that controls configuration, logs error and performance reports, and provides a monitoring and tuning interface for the

system administrator. These functions can be exercised from either system console connected to the host 118, or from a system administrator's workstation.

5 The host processor 118 is a conventional OEM Sun central processor card, Model 3E/120. It incorporates a Motorola 68020 microprocessor and 4MB of on-board memory. Other processors, such as a SPARC-based processor, are also possible.

10 The structure and operation of each of the hardware components of server 100 will now be described in detail.

NETWORK CONTROLLER HARDWARE ARCHITECTURE

15 Fig. 3 is a block diagram showing the data path and some control paths for an illustrative one of the network controllers 110a. It comprises a 20 MHz 68020 microprocessor 210 connected to a 32-bit microprocessor data bus 212. Also connected to the microprocessor data bus 212 is a 256K byte CPU memory 214. The low order 8 bits of the microprocessor data bus 212 are
20 connected through a bidirectional buffer 216 to an 8-bit slow-speed data bus 218. On the slow-speed data bus 218 is a 128K byte EPROM 220, a 32 byte PROM 222, and a multi-function peripheral (MFP) 224. The EPROM 220 contains boot code for the network controller 110a,
25 while the PROM 222 stores various operating parameters

such as the Ethernet addresses assigned to each of the two Ethernet interfaces on the board. Ethernet address information is read into the corresponding interface control block in the CPU memory 214 during
5 initialization. The MFP 224 is a Motorola 68901, and performs various local functions such as timing, interrupts, and general purpose I/O. The MFP 224 also includes a UART for interfacing to an RS232 port 226. These functions are not critical to the invention and
10 will not be further described herein.

The low order 16 bits of the microprocessor data bus 212 are also coupled through a bidirectional buffer 230 to a 16-bit LAN data bus 232. A LAN controller chip 234, such as the Am7990 LANCE Ethernet controller
15 manufactured by Advanced Micro Devices, Inc. Sunnyvale, CA., interfaces the LAN data bus 232 with the first Ethernet 122a shown in Fig. 2. Control and data for the LAN controller 234 are stored in a 512K byte LAN memory 236, which is also connected to the LAN data bus
20 232. A specialized 16 to 32 bit FIFO chip 240, referred to herein as a parity FIFO chip and described below, is also connected to the LAN data bus 232. Also connected to the LAN data bus 232 is a LAN DMA controller 242, which controls movements of packets of
25 data between the LAN memory 236 and the FIFO chip 240.

The LAN DMA controller 242 may be a Motorola M68440 DMA controller using channel zero only.

5 The second Ethernet 122b shown in Fig. 2 connects to a second LAN data bus 252 on the network controller card 110a shown in Fig. 3. The LAN data bus 252 connects to the low order 16 bits of the microprocessor data bus 212 via a bidirectional buffer 250, and has similar components to those appearing on the LAN data bus 232. In particular, a LAN controller 10 254 interfaces the LAN data bus 252 with the Ethernet 122b, using LAN memory 256 for data and control, and a LAN DMA controller 262 controls DMA transfer of data between the LAN memory 256 and the 16-bit wide data port A of the parity FIFO 260.

15 The low order 16 bits of microprocessor data bus 212 are also connected directly to another parity FIFO 270, and also to a control port of a VME/FIFO DMA controller 272. The FIFO 270 is used for passing messages between the CPU memory 214 and one of the 20 remote boards 110, 112, 114, 116 or 118 (Fig. 2) in a manner described below. The VME/FIFO DMA controller 272, which supports three round-robin non-prioritized channels for copying data, controls all data transfers between one of the remote boards and any of the FIFOs 25 240, 260 or 270, as well as between the FIFOs 240 and 260.

-34-

32-bit data bus 274, which is connected to the 32-bit port B of each of the FIFOs 240, 260 and 270, is the data bus over which these transfers take place. Data bus 274 communicates with a local 32-bit bus 276 via a bidirectional pipelining latch 278, which is also controlled by VME/FIFO DMA controller 272 which in turn communicates with the VME bus 120 via a bidirectional buffer 280.

The local data bus 276 is also connected to a set of control registers 282, which are directly addressable across the VME bus 120. The registers 282 are used mostly for system initialization and diagnostics.

The local data bus 276 is also coupled to the microprocessor data bus 212 via a bidirectional buffer 284. When the NC 110a operates in slave mode, the CPU memory 214 is directly addressable from VME bus 120. One of the remote boards can copy data directly from the CPU memory 214 via the bidirectional buffer 284. LAN memories 236 and 256 are not directly addressed over VME bus 120.

The parity FIFOs 240, 260 and 270 each consist of an ASIC, the functions and operation of which are described in the Appendix C. The FIFOs 240 and 260 are configured for packet data transfer and the FIFO 270 is configured for message passing. Referring to the

Attorney Docket No.:AUSP7209
WP1/WSW/AUSP/7209.001

8/24/89-7

Appendix C, the FIFOs 240 and 260 are programmed with the following bit settings in the Data Transfer Configuration Register:

	Bit	Definition	Setting
5	0	WD Mode	N/A
	1	Parity Chip	N/A
	2	Parity Correct Mode	N/A
	3	8/16 bits CPU & PortA interface	16 bits (1)
	4	Invert Port A address 0	no (0)
10	5	Invert Port A address 1	yes (1)
	6	Checksum Carry Wrap	yes (1)
	7	Reset	no (0)

The Data Transfer Control Register is programmed

as follows:

	Bit	Definition	Setting
15	0	Enable PortA Req/Ack	yes (1)
	1	Enable PortB Req/Ack	yes (1)
	2	Data Transfer Direction	(as desired)
	3	CPU parity enable	no (0)
20	4	PortA parity enable	no (0)
	5	PortB parity enable	no (0)
	6	Checksum Enable	yes (1)
	7	PortA Master	yes (1)

Unlike the configuration used on FIFOs 240 and 25 260, the microprocessor 210 is responsible for loading and unloading Port A directly. The microprocessor 210

reads an entire 32-bit word from port A with a single instruction using two port A access cycles. Port A data transfer is disabled by unsetting bits 0 (Enable PortA Req/Ack) and 7 (PortA Master) of the Data Transfer Control Register.

The remainder of the control settings in FIFO 270 are the same as those in FIFOs 240 and 260 described above.

The NC 110a also includes a command FIFO 290. The command FIFO 290 includes an input port coupled to the local data bus 276, and which is directly addressable across the VME bus 120, and includes an output port connected to the microprocessor data bus 212. As explained in more detail below, when one of the remote boards issues a command or response to the NC 110a, it does so by directly writing a 1-word (32-bit) message descriptor into NC 110a's command FIFO 290. Command FIFO 290 generates a "FIFO not empty" status to the microprocessor 210, which then reads the message descriptor off the top of FIFO 290 and processes it. If the message is a command, then it includes a VME address at which the message is located (presumably an address in a shared memory similar to 214 on one of the remote boards). The microprocessor 210 then programs the FIFO 270 and the VME/FIFO DMA controller 272 to

copy the message from the remote location into the CPU memory 214.

Command FIFO 290 is a conventional two-port FIFO, except that additional circuitry is included for
5 generating a Bus Error signal on VME bus 120 if an attempt is made to write to the data input port while the FIFO is full. Command FIFO 290 has space for 256 entries.

A noteworthy feature of the architecture of NC
10 110a is that the LAN buses 232 and 252 are independent of the microprocessor data bus 212. Data packets being routed to or from an Ethernet are stored in LAN memory 236 on the LAN data bus 232 (or 256 on the LAN data bus 252), and not in the CPU memory 214. Data transfer
15 between the LAN memories 236 and 256 and the Ethernets 122a and 122b, are controlled by LAN controllers 234 and 254, respectively, while most data transfer between LAN memory 236 or 256 and a remote port on the VME bus 120 are controlled by LAN DMA controllers 242 and 262,
20 FIFOs 240 and 260, and VME/FIFO DMA controller 272. An exception to this rule occurs when the size of the data transfer is small, e.g., less than 64 bytes, in which case microprocessor 210 copies it directly without using DMA. The microprocessor 210 is not involved in
25 larger transfers except in initiating them and in receiving notification when they are complete.

The CPU memory 214 contains mostly instructions for microprocessor 210, messages being transmitted to or from a remote board via FIFO 270, and various data blocks for controlling the FIFOs, the DMA controllers and the LAN controllers. The microprocessor 210 accesses the data packets in the LAN memories 236 and 256 by directly addressing them through the bidirectional buffers 230 and 250, respectively, for protocol processing. The local high-speed static RAM in CPU memory 214 can therefore provide zero wait state memory access for microprocessor 210 independent of network traffic. This is in sharp contrast to the prior art architecture shown in Fig. 1, in which all data and data packets, as well as microprocessor instructions for host CPU card 10, reside in the memory 16 and must communicate with the host CPU card 10 via the MMU 11.

While the LAN data buses 232 and 252 are shown as separate buses in Fig. 3, it will be understood that they may instead be implemented as a single combined bus.

NETWORK CONTROLLER OPERATION

In operation, when one of the LAN controllers (such as 234) receives a packet of information over its Ethernet 122a, it reads in the entire packet and stores

it in corresponding LAN memory 236. The LAN controller
234 then issues an interrupt to microprocessor 210 via
MFP 224, and the microprocessor 210 examines the status
register on LAN controller 234 (via bidirectional
5 buffer 230) to determine that the event causing the
interrupt was a "receive packet completed." In order
to avoid a potential lockout of the second Ethernet
122b caused by the prioritized interrupt handling
characteristic of MFP 224, the microprocessor 210 does
10 not at this time immediately process the received
packet; instead, such processing is scheduled for a
polling function.

When the polling function reaches the processing
of the received packet, control over the packet is
15 passed to a software link level receive module. The
link level receive module then decodes the packet
according to either of two different frame formats:
standard Ethernet format or SNAP (IEEE 802 LCC) format.
An entry in the header in the packet specifies which
20 frame format was used. The link level driver then
determines which of three types of messages is
contained in the received packet: (1) IP, (2) ARP
packets which can be handled by a local ARP module, or
(3) ARP packets and other packet types which must be
25 forwarded to the local host 118 (Fig. 2) for
processing. If the packet is an ARP packet which can

be handled by the NC 110a, such as a request for the address of server 100, then the microprocessor 210 assembles a response packet in LAN memory 236 and, in a conventional manner, causes LAN controller 234 to
5 transmit that packet back over Ethernet 122a. It is noteworthy that the data manipulation for accomplishing this task is performed almost completely in LAN memory 236, directly addressed by microprocessor 210 as controlled by instructions in CPU memory 214. The
10 function is accomplished also without generating any traffic on the VME backplane 120 at all, and without disturbing the local host 118.

If the received packet is either an ARP packet which cannot be processed completely in the NC 110a, or
15 is another type of packet which requires delivery to the local host 118 (such as a client request for the server 100 to execute a client-defined procedure), then the microprocessor 210 programs LAN DMA controller 242 to load the packet from LAN memory 236
20 into FIFO 240, programs FIFO 240 with the direction of data transfer, and programs DMA controller 272 to read the packet out of FIFO 240 and across the VME bus 120 into system memory 116. In particular, the microprocessor 210 first programs the LAN DMA
25 controller 242 with the starting address and length of the packet in LAN memory 236, and programs the

controller to begin transferring data from the LAN memory 236 to port A of parity FIFO 240 as soon as the FIFO is ready to receive data. Second, microprocessor 210 programs the VME/FIFO DMA controller 272 with the destination address in system memory 116 and the length of the data packet, and instructs the controller to begin transferring data from port B of the FIFO 260 onto VME bus 120. Finally, the microprocessor 210 programs FIFO 240 with the direction of the transfer to take place. The transfer then proceeds entirely under the control of DMA controllers 242 and 262, without any further involvement by microprocessor 210.

The microprocessor 210 then sends a message to host 118 that a packet is available at a specified system memory address. The microprocessor 210 sends such a message by writing a message descriptor to a software-emulated command FIFO on the host, which copies the message from CPU memory 214 on the NC via buffer 284 and into the host's local memory, in ordinary VME block transfer mode. The host then copies the packet from system memory 116 into the host's own local memory using ordinary VME transfers.

If the packet received by NC 110a from the network is an IP packet, then the microprocessor 210 determines whether it is (1) an IP packet for the server 100 which is not an NFS packet; (2) an IP packet to be routed to

a different network; or (3) an NFS packet. If it is an IP packet for the server 100, but not an NFS packet, then the microprocessor 210 causes the packet to be transmitted from the LAN memory 236 to the host 118 in the same manner described above with respect to certain ARP packets.

If the IP packet is not intended for the server 100, but rather is to be routed to a client on a different network, then the packet is copied into the LAN memory associated with the Ethernet to which the destination client is connected. If the destination client is on the Ethernet 122b, which is on the same NC board as the source Ethernet 122a, then the microprocessor 210 causes the packet to be copied from LAN memory 236 into LAN 256 and then causes LAN controller 254 to transmit it over Ethernet 122b. (Of course, if the two LAN data buses 232 and 252 are combined, then copying would be unnecessary; the microprocessor 210 would simply cause the LAN controller 254 to read the packet out of the same locations in LAN memory to which the packet was written by LAN controller 234.)

The copying of a packet from LAN memory 236 to LAN memory 256 takes place similarly to the copying described above from LAN memory to system memory. For transfer sizes of 64 bytes or more, the microprocessor

210 first programs the LAN DMA controller 242 with the starting address and length of the packet in LAN memory 236, and programs the controller to begin transferring data from the LAN memory 236 into port A of parity FIFO 5 240 as soon as the FIFO is ready to receive data. Second, microprocessor 210 programs the LAN DMA controller 262 with a destination address in LAN memory 256 and the length of the data packet, and instructs that controller to transfer data from parity FIFO 260 10 into the LAN memory 256. Third, microprocessor 210 programs the VME/FIFO DMA controller 272 to clock words of data out of port B of the FIFO 240, over the data bus 274, and into port B of FIFO 260. Finally, the microprocessor 210 programs the two FIFOs 240 and 260 15 with the direction of the transfer to take place. The transfer then proceeds entirely under the control of DMA controllers 242, 262 and 272, without any further involvement by the microprocessor 210. Like the copying from LAN memory to system memory, if the 20 transfer size is smaller than 64 bytes, the microprocessor 210 performs the transfer directly, without DMA.

When each of the LAN DMA controllers 242 and 262 complete their work, they so notify microprocessor 210 25 by a respective interrupt provided through MFP 224. When the microprocessor 210 has received both

interrupts, it programs LAN controller 254 to transmit the packet on the Ethernet 122b in a conventional manner.

Thus, IP routing between the two Ethernets in a single network controller 110 takes place over data bus 274, generating no traffic over VME bus 120. Nor is the host processor 118 disturbed for such routing, in contrast to the prior art architecture of Fig. 1. Moreover, all but the shortest copying work is performed by controllers outside microprocessor 210, requiring the involvement of the microprocessor 210, and bus traffic on microprocessor data bus 212, only for the supervisory functions of programming the DMA controllers and the parity FIFOs and instructing them to begin. The VME/FIFO DMA controller 272 is programmed by loading control registers via microprocessor data bus 212; the LAN DMA controllers 242 and 262 are programmed by loading control registers on the respective controllers via the microprocessor data bus 212, respective bidirectional buffers 230 and 250, and respective LAN data buses 232 and 252, and the parity FIFOs 240 and 260 are programmed as set forth in the Appendix C.

If the destination workstation of the IP packet to be routed is on an Ethernet connected to a different one of the network controllers 110, then the packet is

Attorney Docket No.: AUSP7209
WPI/WSW/AUSP/7209.001

8/24/89-7

copied into the appropriate LAN memory on the NC 110 to which that Ethernet is connected. Such copying is accomplished by first copying the packet into system memory 116, in the manner described above with respect
5 to certain ARP packets, and then notifying the destination NC that a packet is available. When an NC is so notified, it programs its own parity FIFO and DMA controllers to copy the packet from system memory 116 into the appropriate LAN memory. It is noteworthy that
10 though this type of IP routing does create VME bus traffic, it still does not involve the host CPU 118.

If the IP packet received over the Ethernet 122a and now stored in LAN memory 236 is an NFS packet intended for the server 100, then the microprocessor
15 210 performs all necessary protocol preprocessing to extract the NFS message and convert it to the local NFS (LNFS) format. This may well involve the logical concatenation of data extracted from a large number of individual IP packets stored in LAN memory 236,
20 resulting in a linked list, in CPU memory 214, pointing to the different blocks of data in LAN memory 236 in the correct sequence.

The exact details of the LNFS format are not important for an understanding of the invention, except
25 to note that it includes commands to maintain a directory of files which are stored on the disks

attached to the storage processors 114, commands for reading and writing data to and from a file on the disks, and various configuration management and diagnostics control messages. The directory maintenance commands which are supported by LNFS include the following messages based on conventional NFS: get attributes of a file (GETATTR); set attributes of a file (SETATTR); look up a file (LOOKUP); create a file (CREATE); remove a file (REMOVE); rename a file (RENAME); create a new linked file (LINK); create a symlink (SYMLINK); remove a directory (RMDIR); and return file system statistics (STATFS). The data transfer commands supported by LNFS include read from a file (READ); write to a file (WRITE); read from a directory (READDIR); and read a link (READLINK). LNFS also supports a buffer release command (RELEASE), for notifying the file controller that an NC is finished using a specified buffer in system memory. It also supports a VOP-derived access command, for determining whether a given type access is legal for specified credential on a specified file.

If the LNFS request includes the writing of file data from the LAN memory 236 to disk, the NC 110a first requests a buffer in system memory 116 to be allocated by the appropriate FC 112. When a pointer to the buffer is returned, microprocessor 210 programs LAN DMA

controller 242, parity FIFO 240 and VME/FIFO DMA
controller 272 to transmit the entire block of file
data to system memory 116. The only difference between
this transfer and the transfer described above for
5 transmitting IP packets and ARP packets to system
memory 116 is that these data blocks will typically
have portions scattered throughout LAN memory 236. The
microprocessor 210 accommodates that situation by
programming LAN DMA controller 242 successively for
10 each portion of the data, in accordance with the linked
list, after receiving notification that the previous
portion is complete. The microprocessor 210 can
program the parity FIFO 240 and the VME/FIFO DMA
controller 272 once for the entire message, as long as
15 the entire data block is to be placed contiguously in
system memory 116. If it is not, then the
microprocessor 210 can program the DMA controller 272
for successive blocks in the same manner LAN DMA
controller 242.

20 If the network controller 110a receives a message
from another processor in server 100, usually from file
controller 112, that file data is available in system
memory 116 for transmission on one of the Ethernets,
for example Ethernet 122a, then the network controller
25 110a copies the file data into LAN memory 236 in a
manner similar to the copying of file data in the

opposite direction. In particular, the microprocessor
210 first programs VME/FIFO DMA controller 272 with the
starting address and length of the data in system
memory 116, and programs the controller to begin
5 transferring data over the VME bus 120 into port B of
parity FIFO 240 as soon as the FIFO is ready to receive
data. The microprocessor 210 then programs the LAN DMA
controller 242 with a destination address in LAN memory
236 and then length of the file data, and instructs
10 that controller to transfer data from the parity FIFO
240 into the LAN memory 236. Third, microprocessor
210 programs the parity FIFO 240 with the direction of
the transfer to take place. The transfer then proceeds
entirely under the control of DMA controllers 242 and
15 272, without any further involvement by the
microprocessor 210. Again, if the file data is
scattered in multiple blocks in system memory 116, the
microprocessor 210 programs the VME/FIFO DMA controller
272 with a linked list of the blocks to transfer in the
20 proper order.

When each of the DMA controllers 242 and 262
complete their work, they so notify microprocessor 210
through MFP 224. The microprocessor 210 then performs
all necessary protocol processing on the LNFS message
25 in LAN memory 236 in order to prepare the message for
transmission over the Ethernet 122a in the form of

Ethernet IP packets. As set forth above, this protocol processing is performed entirely in network controller 110a, without any involvement of the local host 118.

5 It should be noted that the parity FIFOs are designed to move multiples of 128-byte blocks most efficiently. The data transfer size through port B is always 32-bits wide, and the VME address corresponding to the 32-bit data must be quad-byte aligned. The data transfer size for port A can be either 8 or 16 bits.
10 For bus utilization reasons, it is set to 16 bits when the corresponding local start address is double-byte aligned, and is set at 8 bits otherwise. The TCP/IP checksum is always computed in the 16 bit mode. Therefore, the checksum word requires byte swapping if
15 the local start address is not double-byte aligned.

Accordingly, for transfer from port B to port A of any of the FIFOs 240, 260 or 270, the microprocessor 210 programs the VME/FIFO DMA controller to pad the transfer count to the next 128-byte boundary. The
20 extra 32-bit word transfers do not involve the VME bus, and only the desired number of 32-bit words will be unloaded from port A.

For transfers from port A to port B of the parity FIFO 270, the microprocessor 210 loads port A word-by-
25 word and forces a FIFO full indication when it is finished. The FIFO full indication enables unloading

from port B. The same procedure also takes place for transfers from port A to port B of either of the parity FIFOs 240 or 260, since transfers of fewer than 128 bytes are performed under local microprocessor control rather than under the control of LAN DMA controller 242 or 262. For all of the FIFOs, the VME/FIFO DMA controller is programmed to unload only the desired number of 32-bit words.

FILE CONTROLLER HARDWARE ARCHITECTURE

10 The file controllers (FC) 112 may each be a standard off-the-shelf microprocessor board, such as one manufactured by Motorola Inc. Preferably, however, a more specialized board is used such as that shown in block diagram form in Fig. 4.

15 Fig. 4 shows one of the FCs 112a, and it will be understood that the other FC can be identical. In many aspects it is simply a scaled-down version of the NC 110a shown in Fig. 3, and in some respects it is scaled up. Like the NC 110a, FC 112a comprises a 20MHz 68020
20 microprocessor 310 connected to a 32-bit microprocessor data bus 312. Also connected to the microprocessor data bus 312 is a 256K byte shared CPU memory 314. The low order 8 bits of the microprocessor data bus 312 are connected through a bidirectional buffer 316 to an
25 8-bit slow-speed data bus 318. On slow-speed data bus

318 are a 128K byte PROM 320, and a multifunction peripheral (MFP) 324. The functions of the PROM 320 and MFP 324 are the same as those described above with respect to EPROM 220 and MFP 224 on NC 110a. FC 112a
5 does not include PROM like the PROM 222 on NC 110a, but does include a parallel port 392. The parallel port 392 is mainly for testing and diagnostics.

Like the NC 110a, the FC 112a is connected to the VME bus 120 via a bidirectional buffer 380 and a 32-bit local data bus 376. A set of control registers 382
10 are connected to the local data bus 376, and directly addressable across the VME bus 120. The local data bus 376 is also coupled to the microprocessor data bus 312 via a bidirectional buffer 384. This permits the
15 direct addressability of CPU memory 314 from VME bus 120.

FC 112a also includes a command FIFO 390, which includes an input port coupled to the local data bus 376 and which is directly addressable across the VME
20 bus 120. The command FIFO 390 also includes an output port connected to the microprocessor data bus 312. The structure, operation and purpose of command FIFO 390 are the same as those described above with respect to command FIFO 290 on NC 110a.

25 The FC 112a omits the LAN data buses 232 and 252 which are present in NC 110a, but instead includes a 4

megabyte 32-bit wide FC memory 396 coupled to the microprocessor data bus 312 via a bidirectional buffer 394. As will be seen, FC memory 396 is used as a cache memory for file control information, separate from the file data information cached in system memory 116.

The file controller embodiment shown in Fig. 4 does not include any DMA controllers, and hence cannot act as a master for transmitting or receiving data in any block transfer mode, over the VME bus 120. Block transfers do occur with the CPU memory 314 and the FC memory 396, however, with the FC 112a acting as an VME bus slave. In such transfers, the remote master addresses the CPU memory 314 or the FC memory 396 directly over the VME bus 120 through the bidirectional buffers 384 and, if appropriate, 394.

FILE CONTROLLER OPERATION

The purpose of the FC 112a is basically to provide virtual file system services in response to requests provided in LNFS format by remote processors on the VME bus 120. Most requests will come from a network controller 110, but requests may also come from the local host 118.

The file related commands supported by LNFS are identified above. They are all specified to the FC 112a in terms of logically identified disk data blocks.

For example, the LNFS command for reading data from a file includes a specification of the file from which to read (file system ID (FSID) and file ID (inode)), a byte offset, and a count of the number of bytes to read. The FC 112a converts that identification into physical form, namely disk and sector numbers, in order to satisfy the command.

The FC 112a runs a conventional Fast File System (FFS or UFS), which is based on the Berkeley 4.3 VAX release. This code performs the conversion and also performs all disk data caching and control data caching. However, as previously mentioned, control data caching is performed using the FC memory 396 on FC 112a, whereas disk data caching is performed using the system memory 116 (Fig. 2). Caching this file control information within the FC 112a avoids the VME bus congestion and speed degradation which would result if file control information was cached in system memory 116.

The memory on the FC 112a is directly accessed over the VME bus 120 for three main purposes. First, and by far the most frequent, are accesses to FC memory 396 by an SP 114 to read or write cached file control information. These are accesses requested by FC 112a to write locally modified file control structures through to disk, or to read file control structures

from disk. Second, the FC's CPU memory 314 is accessed directly by other processors for message transmissions from the FC 112a to such other processors. For example, if a data block in system memory is to be transferred to an SP 114 for writing to disk, the FC 112a first assembles a message in its local memory 314 requesting such a transfer. The FC 112a then notifies the SP 114, which copies the message directly from the CPU memory 314 and executes the requested transfer.

10 A third type of direct access to the FC's local memory occurs when an LNFS client reads directory entries. When FC 112a receives an LNFS request to read directory entries, the FC 112a formats the requested directory entries in FC memory 396 and notifies the requestor of their location. The requestor then directly accesses FC memory 396 to read the entries.

The version of the UFS code on FC 112a includes some modifications in order to separate the two caches. In particular, two sets of buffer headers are maintained, one for the FC memory 396 and one for the system memory 116. Additionally, a second set of the system buffer routines (GETBLK(), BRELSE(), BREAD(), BWRITE(), and BREADA()) exist, one for buffer accesses to FC Mem 396 and one for buffer accesses to system memory 116. The UFS code is further modified to call

the appropriate buffer routines for FC memory 396 for
accesses to file control information, and to call the
appropriate buffer routines for the system memory 116
for the caching of disk data. A description of UFS may
5 be found in chapters 2, 6, 7 and 8 of "Kernel Structure
and Flow," by Rieken and Webb of .sh consulting (Santa
Clara, California: 1988), incorporated herein by
reference.

When a read command is sent to the FC by a
10 requestor such as a network controller, the FC first
converts the file, offset and count information into
disk and sector information. It then locks the system
memory buffers which contain that information,
instructing the storage processor 114 to read them from
15 disk if necessary. When the buffer is ready, the FC
returns a message to the requestor containing both the
attributes of the designated file and an array of
buffer descriptors that identify the locations in
system memory 116 holding the data.

20 After the requestor has read the data out of the
buffers, it sends a release request back to the FC.
The release request is the same message that was
returned by the FC in response to the read request; the
FC 112a uses the information contained therein to
25 determine which buffers to free.

A write command is processed by FC 112a similarly to the read command, but the caller is expected to write to (instead of read from) the locations in system memory 116 identified by the buffer descriptors returned by the FC 112a. Since FC 112a employs write-through caching, when it receives the release command from the requestor, it instructs storage processor 114 to copy the data from system memory 116 onto the appropriate disk sectors before freeing the system memory buffers for possible reallocation.

The READDIR transaction is similar to read and write, but the request is satisfied by the FC 112a directly out of its own FC memory 396 after formatting the requested directory information specifically for this purpose. The FC 112a causes the storage processor read the requested directory information from disk if it is not already locally cached. Also, the specified offset is a "magic cookie" instead of a byte offset, identifying directory entries instead of an absolute byte offset into the file. No file attributes are returned.

The READLINK transaction also returns no file attributes, and since links are always read in their entirety, it does not require any offset or count.

For all of the disk data caching performed through system memory 116, the FC 112a acts as a central

authority for dynamically allocating, deallocating and keeping track of buffers. If there are two or more FCs 112, each has exclusive control over its own assigned portion of system memory 116. In all of these transactions, the requested buffers are locked during the period between the initial request and the release request. This prevents corruption of the data by other clients.

Also in the situation where there are two or more FCs, each file system on the disks is assigned to a particular one of the FCs. FC #0 runs a process called FC_VICE_PRESIDENT, which maintains a list of which file systems are assigned to which FC. When a client processor (for example an NC 110) is about to make an LNFS request designating a particular file system, it first sends the fsid in a message to the FC_VICE_PRESIDENT asking which FC controls the specified file system. The FC_VICE_PRESIDENT responds, and the client processor sends the LNFS request to the designated FC. The client processor also maintains its own list of fsid/FC pairs as it discovers them, so as to minimize the number of such requests to the FC_VICE_PRESIDENT.

STORAGE PROCESSOR HARDWARE ARCHITECTURE

Attorney Docket No.:AUSP7209
WP1/WSW/AUSP/7209.001

8/24/89-7

In the file server 100, each of the storage processors 114 can interface the VME bus 120 with up to 10 different SCSI buses. Additionally, it can do so at the full usage rate of an enhanced block transfer protocol of 55MB per second.

Fig. 5 is a block diagram of one of the SPs 114a. SP 114b is identical. SP 114a comprises a microprocessor 510, which may be a Motorola 68020 microprocessor operating at 20MHz. The microprocessor 510 is coupled over a 32-bit microprocessor data bus 512 with CPU memory 514, which may include up to 1MB of static RAM. The microprocessor 510 accesses instructions, data and status on its own private bus 512, with no contention from any other source. The microprocessor 510 is the only master of bus 512.

The low order 16 bits of the microprocessor data bus 512 interface with a control bus 516 via a bidirectional buffer 518. The low order 8 bits of the control bus 516 interface with a slow speed bus 520 via another bidirectional buffer 522. The slow speed bus 520 connects to an MFP 524, similar to the MFP 224 in NC 110a (Fig. 3), and with a PROM 526, similar to PROM 220 on NC 110a. The PROM 526 comprises 128K bytes of EPROM which contains the functional code for SP 114a. Due to the width and speed of the PROM 526, the

functional code is copied to CPU memory 514 upon reset for faster execution.

MFP 524, like the MFP 224 on NC 110a, comprises a Motorola 68901 multifunction peripheral device. It provides the functions of a vectored interrupt controller, individually programmable I/O pins, four timers and a UART. The UART functions provide serial communications across an RS 232 bus (not shown in Fig. 5) for debug monitors and diagnostics. Two of the four timing functions may be used as general-purpose timers by the microprocessor 510, either independently or in cascaded fashion. A third timer function provides the refresh clock for a DMA controller described below, and the fourth timer generates the UART clock. Additional information on the MFP 524 can be found in "MC 68901 Multi-Function Peripheral Specification," by Motorola, Inc., which is incorporated herein by reference.

The eight general-purpose I/O bits provided by MFP 524 are configured according to the following table:

Bit Direction Definition

	7	input	Power Failure is Imminent - This functions as an early warning.
5	6	input	SCSI Attention - A composite of the SCSI. Attentions from all 10 SCSI channels.
10	5	input	Channel Operation Done - A composite of the channel done bits from all 13 channels of the DMA controller, described below.
15	4	output	DMA Controller Enable. Enables the DMA Controller to run.
	3	input	VMEbus Interrupt Done - Indicates the completion of a VMEbus Interrupt.
20	2	input	Command Available - Indicates that the SP'S Command Fifo, described below, contains one or more command pointers.
25	1	output	External Interrupts Disable. Disables externally generated interrupts to the microprocessor 510.
	0	output	Command Fifo Enable. Enables operation of the SP'S Command Fifo. Clears the Command Fifo when reset.

30 Commands are provided to the SP 114a from the VME bus 120 via a bidirectional buffer 530, a local data bus 532, and a command FIFO 534. The command FIFO 534 is similar to the command FIFOs 290 and 390 on NC 110a and FC 112a, respectively, and has a depth of 256 32-bit entries. The command FIFO 534 is a write-only register as seen on the VME bus 120, and as a read-only register as seen by microprocessor 510. If the FIFO is full at the beginning of a write from the VME bus, a VME bus error is generated. Pointers are

Attorney Docket No.:AUSP7209
WP1/WSW/AUSP/7209.001

8/24/89-7

removed from the command FIFO 534 in the order received, and only by the microprocessor 510. Command available status is provided through I/O bit 4 of the MFP 524, and as long as one or more command pointers
5 are still within the command FIFO 534, the command available status remains asserted.

As previously mentioned, the SP 114a supports up to 10 SCSI buses or channels 540a-540j. In the typical configuration, buses 540a-540i support up to 3 SCSI
10 disk drives each, and channel 540j supports other SCSI peripherals such as tape drives, optical disks, and so on. Physically, the SP 114a connects to each of the SCSI buses with an ultra-miniature D sub connector and round shielded cables. Six 50-pin cables provide 300
15 conductors which carry 18 signals per bus and 12 grounds. The cables attach at the front panel of the SP 114a and to a commutator board at the disk drive array. Standard 50-pin cables connect each SCSI device to the commutator board. Termination resistors are
20 installed on the SP 114a.

The SP 114a supports synchronous parallel data transfers up to 5MB per second on each of the SCSI buses 540, arbitration, and disconnect/reconnect services. Each SCSI bus 540 is connected to a
25 respective SCSI adaptor 542, which in the present embodiment is an AIC 6250 controller IC manufactured by

Adaptec Inc., Milpitas, California, operating in the non-multiplexed address bus mode. The AIC 6250 is described in detail in "AIC-6250 Functional Specification," by Adaptec Inc., which is incorporated
5 herein by reference. The SCSI adaptors 542 each provide the necessary hardware interface and low-level electrical protocol to implement its respective SCSI channel.

The 8-bit data port of each of the SCSI adaptors
10 542 is connected to port A of a respective one of a set of ten parity FIFOs 544a-544j. The FIFOs 544 are the same as FIFOs 240, 260 and 270 on NC 110a, and are connected and configured to provide parity covered data transfers between the 8-bit data port of the respective
15 SCSI adaptors 542 and a 36-bit (32-bit plus 4 bits of parity) common data bus 550. The FIFOs 544 provide handshake, status, word assembly/disassembly and speed matching FIFO buffering for this purpose. The FIFOs 544 also generate and check parity for the 32-bit bus,
20 and for RAID 5 implementations they accumulate and check redundant data and accumulate recovered data.

All of the SCSI adaptors 542 reside at a single location of the address space of the microprocessor 510, as do all of the parity FIFOs 544. The
25 microprocessor 510 selects individual controllers and FIFOs for access in pairs, by first programming a pair

select register (not shown) to point to the desired pair and then reading from or writing to the control register address of the desired chip in the pair. The microprocessor 510 communicates with the control registers on the SCSI adaptors 542 via the control bus 516 and an additional bidirectional buffer 546, and communicates with the control registers on FIFOs 544 via the control bus 516 and a bidirectional buffer 552. Both the SCSI adaptors 542 and FIFOs 544 employ 8-bit control registers, and register addressing of the FIFOs 544 is arranged such that such registers alias in consecutive byte locations. This allows the microprocessor 510 to write to the registers as a single 32-bit register, thereby reducing instruction overhead.

The parity FIFOs 544 are each configured in their Adaptec 6250 mode. Referring to the Appendix C, the FIFOs 544 are programmed with the following bit settings in the Data Transfer Configuration Register:

Bit	Definition	Setting
0	WD Mode	(0)
1	Parity Chip	(1)
2	Parity Correct Mode	(0)
3	8/16 bits CPU & PortA interface	(0)
4	Invert Port A address 0	(1)
5	Invert Port A address 1	(1)

Attorney Docket No.: A USP7209
 WPI/WSW/AUSP/7209.001

8/24/89-7

6 Checksum Carry Wrap (0)
7 Reset (0)

The Data Transfer Control Register is programmed as follows:

5	<u>Bit</u>	<u>Definition</u>	<u>Setting</u>
	0	Enable PortA Req/Ack	(1)
	1	Enable PortB Req/Ack	(1)
	2	Data Transfer Direction	as desired
	3	CPU parity enable	(0)
10	4	PortA parity enable	(1)
	5	PortB parity enable	(1)
	6	Checksum Enable	(0)
	7	PortA Master	(0)

In addition, bit 4 of the RAM Access Control Register (Long Burst) is programmed for 8-byte bursts.

SCSI adaptors 542 each generate a respective interrupt signal, the status of which are provided to microprocessor 510 as 10 bits of a 16-bit SCSI interrupt register 556. The SCSI interrupt register 556 is connected to the control bus 516. Additionally, a composite SCSI interrupt is provided through the MFP 524 whenever any one of the SCSI adaptors 542 needs servicing.

An additional parity FIFO 554 is also provided in the SP 114a, for message passing. Again referring to

the Appendix C, the parity FIFO 554 is programmed with the following bit settings in the Data Transfer

Configuration Register:

Bit	Definition	Setting	
5	0	WD Mode	(0)
	1	Parity Chip	(1)
	2	Parity Correct Mode	(0)
	3	8/16 bits CPU & PortA interface	(1)
	4	Invert Port A address 0	(1)
10	5	Invert Port A address 1	(1)
	6	Checksum Carry Wrap	(0)
	7	Reset	(0)

The Data Transfer Control Register is programmed

as follows:

Bit	Definition	Setting	
15	0	Enable PortA Req/Ack	(0)
	1	Enable PortB Req/Ack	(1)
	2	Data Transfer Direction	as desired
	3	CPU parity enable	(0)
20	4	PortA parity enable	(0)
	5	PortB parity enable	(1)
	6	Checksum Enable	(0)
	7	PortA Master	(0)

In addition, bit 4 of the RAM Access Control Register (Long Burst) is programmed for 8-byte bursts.

Port A of FIFO 554 is connected to the 16-bit control bus 516, and port B is connected to the common data bus 550. FIFO 554 provides one means by which the microprocessor 510 can communicate directly with the VME bus 120, as is described in more detail below.

The microprocessor 510 manages data movement using a set of 15 channels, each of which has an unique status which indicates its current state. Channels are implemented using a channel enable register 560 and a channel status register 562, both connected to the control bus 516. The channel enable register 560 is a 16-bit write-only register, whereas the channel status register 562 is a 16-bit read-only register. The two registers reside at the same address to microprocessor 510. The microprocessor 510 enables a particular channel by setting its respective bit in channel enable register 560, and recognizes completion of the specified operation by testing for a "done" bit in the channel status register 562. The microprocessor 510 then resets the enable bit, which causes the respective "done" bit in the channel status register 562 to be cleared.

The channels are defined as follows:

<u>CHANNEL</u>	<u>FUNCTION</u>
5 0:9	These channels control data movement to and from the respective FIFOs 544 via the common data bus 550. When a FIFO is enabled and a request is received from it, the channel becomes ready. Once the channel has been serviced a status of done is generated.
10 11:10	These channels control data movement between a local data buffer 564, described below, and the VME bus 120. When enabled the channel becomes ready. Once the channel has been serviced a status of done is generated.
15 12	When enabled, this channel causes the DRAM in local data buffer 564 to be refreshed based on a clock which is generated by the MFP 524. The refresh consists of a burst of 16 rows. This channel does not generate a status of done.
20 13	The microprocessor's communication FIFO 554 is serviced by this channel. When enable is set and the FIFO 554 asserts a request then the channel becomes ready. This channel generates a status of done.
25 14	Low latency writes from microprocessor 510 onto the VME bus 120 are controlled by this channel. When this channel is enabled data is moved from a special 32 bit register, described below, onto the VME bus 120. This channel generates a done status.
30 15	This is a null channel for which neither a ready status nor done status is generated.

Channels are prioritized to allow servicing of the
40 more critical requests first. Channel priority is assigned in a descending order starting at channel 14. That is, in the event that all channels are requesting service, channel 14 will be the first one served.

The common data bus 550 is coupled via a bidirectional register 570 to a 36-bit junction bus 572. A second bidirectional register 574 connects the junction bus 572 with the local data bus 532. Local data buffer 564, which comprises 1MB of DRAM, with parity, is coupled bidirectionally to the junction bus 572. It is organized to provide 256K 32-bit words with byte parity. The SP 114a operates the DRAMs in page mode to support a very high data rate, which requires bursting of data instead of random single-word accesses. It will be seen that the local data buffer 564 is used to implement a RAID (redundant array of inexpensive disks) algorithm, and is not used for direct reading and writing between the VME bus 120 and a peripheral on one of the SCSI buses 540.

A read-only register 576, containing all zeros, is also connected to the junction bus 572. This register is used mostly for diagnostics, initialization, and clearing of large blocks of data in system memory 116.

The movement of data between the FIFOs 544 and 554, the local data buffer 564, and a remote entity such as the system memory 116 on the VME bus 120, is all controlled by a VME/FIFO DMA controller 580. The VME/FIFO DMA controller 580 is similar to the VME/FIFO DMA controller 272 on network controller 110a (Fig. 3), and is described in the Appendix.A. Briefly, it

Attorney Docket No.:AUSP7209
WPI/WSW/AUSP/7209.001

8/24/89-7

includes a bit slice engine 582 and a dual-port static RAM 584. One port of the dual-port static RAM 584 communicates over the 32-bit microprocessor data bus 512 with microprocessor 510, and the other port
5 communicates over a separate 16-bit bus with the bit slice engine 582. The microprocessor 510 places command parameters in the dual-port RAM 584, and uses the channel enables 560 to signal the VME/FIFO DMA controller 580 to proceed with the command. The
10 VME/FIFO DMA controller is responsible for scanning the channel status and servicing requests, and returning ending status in the dual-port RAM 584. The dual-port RAM 584 is organized as 1K x 32 bits at the 32-bit port and as 2K x 16 bits at the 16-bit port. An example
15 showing the method by which the microprocessor 510 controls the VME/FIFO DMA controller 580 is as follows. First, the microprocessor 510 writes into the dual-port RAM 584 the desired command and associated parameters for the desired channel. For example, the command
20 might be, "copy a block of data from FIFO 544h out into a block of system memory 116 beginning at a specified VME address." Second, the microprocessor sets the channel enable bit in channel enable register 560 for the desired channel.

25 At the time the channel enable bit is set, the appropriate FIFO may not yet be ready to send data.

Only when the VME/FIFO DMA controller 580 does receive a "ready" status from the channel, will the controller 580 execute the command. In the meantime, the DMA controller 580 is free to execute commands and move data to or from other channels.

When the DMA controller 580 does receive a status of "ready" from the specified channel, the controller fetches the channel command and parameters from the dual-ported RAM 584 and executes. When the command is complete, for example all the requested data has been copied, the DMA controller writes status back into the dual-port RAM 584 and asserts "done" for the channel in channel status register 562. The microprocessor 510 is then interrupted, at which time it reads channel status register 562 to determine which channel interrupted. The microprocessor 510 then clears the channel enable for the appropriate channel and checks the ending channel status in the dual-port RAM 584.

In this way a high-speed data transfer can take place under the control of DMA controller 580, fully in parallel with other activities being performed by microprocessor 510. The data transfer takes place over busses different from microprocessor data bus 512, thereby avoiding any interference with microprocessor instruction fetches.

The SP 114a also includes a high-speed register 590, which is coupled between the microprocessor data bus 512 and the local data bus 532. The high-speed register 590 is used to write a single 32-bit word to an VME bus target with a minimum of overhead. The register is write only as viewed from the microprocessor 510. In order to write a word onto the VME bus 120, the microprocessor 510 first writes the word into the register 590, and the desired VME target address into dual-port RAM 584. When the microprocessor 510 enables the appropriate channel in channel enable register 560, the DMA controller 580 transfers the data from the register 590 into the VME bus address specified in the dual-port RAM 584. The DMA controller 580 then writes the ending status to the dual-port RAM and sets the channel "done" bit in channel status register 562.

This procedure is very efficient for transfer of a single word of data, but becomes inefficient for large blocks of data. Transfers of greater than one word of data, typically for message passing, are usually performed using the FIFO 554.

The SP 114a also includes a series of registers 592, similar to the registers 282 on NC 110a (Fig. 3) and the registers 382 on FC 112a (Fig. 4). The details

of these registers are not important for an understanding of the present invention.

STORAGE PROCESSOR OPERATION

5 The 30 SCSI disk drives supported by each of the
SPs 114 are visible to a client processor, for example
one of the file controllers 112, either as three large,
logical disks or as 30 independent SCSI drives,
depending on configuration. When the drives are
visible as three logical disks, the SP uses RAID 5
10 design algorithms to distribute data for each logical
drive on nine physical drives to minimize disk arm
contention. The tenth drive is left as a spare. The
RAID 5 algorithm (redundant array of inexpensive
drives, revision 5) is described in "A Case For a
15 Redundant Arrays of Inexpensive Disks (RAID)", by
Patterson et al., published at ACM SIGMOD Conference,
Chicago, Ill., June 1-3, 1988, incorporated herein by
reference.

20 In the RAID 5 design, disk data are divided into
stripes. Data stripes are recorded sequentially on
eight different disk drives. A ninth parity stripe, the
exclusive-or of eight data stripes, is recorded on a
ninth drive. If a stripe size is set to 8K bytes, a
read of 8K of data involves only one drive. A write of
25 8K of data involves two drives: a data drive and a

Attorney Docket No.:AUSP7209
WP1/WSW/AUSP/7209.001

8/24/89-7

parity drive. Since a write requires the reading back
of old data to generate a new parity stripe, writes are
also referred to as modify writes. The SP 114a
supports nine small reads to nine SCSI drives
5 concurrently. When stripe size is set to 8K, a read of
64K of data starts all eight SCSI drives, with each
drive reading one 8K stripe worth of data. The parallel
operation is transparent to the caller client.

The parity stripes are rotated among the nine
10 drives in order to avoid drive contention during write
operations. The parity stripe is used to improve
availability of data. When one drive is down, the SP
114a can reconstruct the missing data from a parity
stripe. In such case, the SP 114a is running in error
15 recovery mode. When a bad drive is repaired, the SP
114a can be instructed to restore data on the repaired
drive while the system is on-line.

When the SP 114a is used to attach thirty
independent SCSI drives, no parity stripe is created
20 and the client addresses each drive directly.

The SP 114a processes multiple messages
(transactions, commands) at one time, up to 200
messages per second. The SP 114a does not initiate any
messages after initial system configuration. The
25 following SP 114a operations are defined:

095447/2

- 01 No Op
- 02 Send Configuration Data
- 03 Receive Configuration Data
- 05 Read and Write Sectors
- 5 06 Read and Write Cache Pages
- 07 IOCTL Operation
- 08 Dump SP 114a Local Data Buffer
- 09 Start/Stop A SCSI Drive
- 0C Inquiry
- 10 0E Read Message Log Buffer
- 0F Set SP 114a Interrupt

The above transactions are described in detail in the above-identified application entitled MULTIPLE FACILITY OPERATING SYSTEM ARCHITECTURE. For an understanding of the invention, it will be useful to describe the function and operation of only two of these commands: read and write sectors, and read and write cache pages.

Read and Write Sectors

This command, issued usually by an FC 112, causes the SP 114a to transfer data between a specified block of system memory and a specified series of contiguous sectors on the SCSI disks. As previously described in connection with the file controller 112, the particular sectors are identified in physical terms. In

Attorney Docket No.:AUSP7209
WP1/WSW/AUSP/7209.001

8/24/89-7

particular, the particular disk sectors are identified by SCSI channel number (0-9), SCSI ID on that channel number (0-2), starting sector address on the specified drive, and a count of the number of sectors to read or write. The SCSI channel number is zero if the SP 114a is operating under RAID 5.

The SP 114a can execute up to 30 messages on the 30 SCSI drives simultaneously. Unlike most of the commands to an SP 114, which are processed by microprocessor 510 as soon as they appear on the command FIFO 534, read and write sectors commands (as well as read and write cache memory commands) are first sorted and queued. Hence, they are not served in the order of arrival.

When a disk access command arrives, the microprocessor 510 determines which disk drive is targeted and inserts the message in a queue for that disk drive sorted by the target sector address. The microprocessor 510 executes commands on all the queues simultaneously, in the order present in the queue for each disk drive. In order to minimize disk arm movements, the microprocessor 510 moves back and forth among queue entries in an elevator fashion.

If no error conditions are detected from the SCSI disk drives, the command is completed normally. When a data check error condition occurs and the SP 114a is

configured for RAID 5, recovery actions using
redundant data begin automatically. When a drive is
down while the SP 114a is configured for RAID 5,
recovery actions similar to data check recovery take
5 place.

Read/Write Cache Pages

This command is similar to read and write sectors,
except that multiple VME addresses are provided for
transferring disk data to and from system memory 116.
10 Each VME address points to a cache page in system
memory 116, the size of which is also specified in the
command. When transferring data from a disk to system
memory 116, data are scattered to different cache
pages; when writing data to a disk, data are gathered
15 from different cache pages in system memory 116.
Hence, this operation is referred to as a scatter-
gather function.

The target sectors on the SCSI disks are specified
in the command in physical terms, in the same manner
20 that they are specified for the read and write sectors
command. Termination of the command with or without
error conditions is the same as for the read and write
sectors command.

The dual-port RAM 584 in the DMA controller 580
25 maintains a separate set of commands for each channel

controlled by the bit slice engine 582. As each channel completes its previous operation, the microprocessor 510 writes a new DMA operation into the dual-port RAM 584 for that channel in order to satisfy the next operation on a disk elevator queue.

The commands written to the DMA controller 580 include an operation code and a code indicating whether the operation is to be performed in non-block mode, in standard VME block mode, or in enhanced block mode. The operation codes supported by DMA controller 580 are as follows:

<u>OP CODE</u>	<u>OPERATION</u>	
0	NO-OP	
1	ZEROES -> BUFFER	Move zeros from zeros register 576 to local data buffer 564.
2	ZEROES -> FIFO	Move zeros from zeros register 576 to the currently selected FIFO on common data bus 550.
3	ZEROES -> VMEbus	Move zeros from zeros register 576 out onto the VME bus 120. Used for initializing cache buffers in system memory 116.

- 4 VMEbus -> BUFFER Move data from the VME bus 120 to the local data buffer 564. This operation is used during a write, to move target data intended for a down drive into the buffer for participation in redundancy generation. Used only for RAID 5 application.
- 5
- 10
- 5 VMEbus -> FIFO New data to be written from VME bus onto a drive. Since RAID 5 requires redundancy data to be generated from data that is buffered in local data buffer 564, this operation will be used only if the SP 114a is not configured for RAID 5.
- 15
- 20
- 6 VMEbus -> BUFFER & FIFO Target data is moved from VME bus 120 to a SCSI device and is also captured in the local data buffer 564 for participation in redundancy generation. Used only if SP 114a is configured for RAID 5 operation.
- 25
- 30
- 7 BUFFER -> VMEbus This operation is not used.
- 35
- 8 BUFFER -> FIFO Participating data is transferred to create redundant data or recovered data on a disk drive. Used only in RAID 5 applications.
- 40
- 9 FIFO -> VMEbus This operation is used to move target data directly from a disk drive onto the VME bus 120.
- 45

- 5 A FIFO -> BUFFER U s e d t o m o v e
 participating data for
 recovery and modify
 operations. Used only in
 RAID 5 applications.

- 10 B FIFO -> VMEbus & BUFFER
 This operation is used to
 save target data for
 participation in data
 recovery. Used only in
 RAID 5 applications.

SYSTEM MEMORY

Fig. 6 provides a simplified block diagram of the preferred architecture of one of the system memory cards 116a. Each of the other system memory cards are the same. Each memory card 116 operates as a slave on the enhanced VME bus 120 and therefore requires no on-board CPU. Rather, a timing control block 610 is sufficient to provide the necessary slave control operations. In particular, the timing control block 610, in response to control signals from the control portion of the enhanced VME bus 120, enables a 32-bit wide buffer 612 for an appropriate direction transfer of 32-bit data between the enhanced VME bus 120 and a multiplexer unit 614. The multiplexer 614 provides a multiplexing and demultiplexing function, depending on data transfer direction, for a six megabit by seventy-two bit word memory array 620. An error correction code (ECC) generation and testing unit 622 is also connected to the multiplexer 614 to generate or verify,

again depending on transfer direction, eight bits of ECC data. The status of ECC verification is provided back to the timing control block 610.

ENHANCED VME BUS PROTOCOL

5 VME bus 120 is physically the same as an ordinary VME bus, but each of the NCs and SPs include additional circuitry and firmware for transmitting data using an enhanced VME block transfer protocol. The enhanced protocol is described in detail in the above-identified
10 application entitled ENHANCED VMEBUS PROTOCOL UTILIZING PSEUDOSYNCHRONOUS HANDSHAKING AND BLOCK MODE DATA TRANSFER, and summarized in the Appendix B hereto. Typically transfers of LNFS file data between NCs and system memory, or between SPs and system memory, and
15 transfers of packets being routed from one NC to another through system memory, are the only types of transfers that use the enhanced protocol in server 100. All other data transfers on VME bus 120 use either conventional VME block transfer protocols or ordinary
20 non-block transfer protocols.

MESSAGE PASSING

As is evident from the above description, the different processors in the server 100 communicate with each other via certain types of messages. In software,

Attorney Docket No.:AUSP7209
WP1/WSW/AUSP/7209.001

8/24/89-7

these messages are all handled by the messaging kernel, described in detail in the MULTIPLE FACILITY OPERATING SYSTEM ARCHITECTURE application cited above. In hardware, they are implemented as follows.

5 Each of the NCs 110, each of the FCs 112, and each of the SPs 114 includes a command or communication FIFO such as 290 on NC 110a. The host 118 also includes a command FIFO, but since the host is an unmodified purchased processor board, the FIFO is emulated in
10 software. The write port of the command FIFO in each of the processors is directly addressable from any of the other processors over VME bus 120.

 Similarly, each of the processors except SPs 114 also includes shared memory such as CPU memory 214 on
15 NC 110a. This shared memory is also directly addressable by any of the other processors in the server 100.

 If one processor, for example network controller 110a, is to send a message or command to a second
20 processor, for example file controller 112a, then it does so as follows. First, it forms the message in its own shared memory (e.g., in CPU memory 214 on NC 110a). Second, the microprocessor in the sending processor directly writes a message descriptor into the command
25 FIFO in the receiving processor. For a command being sent from network controller 110a to file controller

112a, the microprocessor 210 would perform the write via buffer 284 on NC 110a, VME bus 120, and buffer 384 on file controller 112a.

The command descriptor is a single 32-bit word containing in its high order 30 bits a VME address indicating the start of a quad-aligned message in the sender's shared memory. The low order two bits indicate the message type as follows:

	<u>Type</u>	<u>Description</u>
10	0	Pointer to a new message being sent
	1	Pointer to a reply message
	2	Pointer to message to be forwarded
	3	Pointer to message to be freed; also message acknowledgment

15 All messages are 128-bytes long.

When the receiving processor reaches the command descriptor on its command FIFO, it directly accesses the sender's shared memory and copies it into the receiver's own local memory. For a command issued from network controller 110a to file controller 112a, this would be an ordinary VME block or non-block mode transfer from NC CPU memory 214, via buffer 284, VME bus 120 and buffer 384, into FC CPU memory 314. The FC microprocessor 310 directly accesses NC CPU memory 214 for this purpose over the VME bus 120.

When the receiving processor has received the command and has completed its work, it sends a reply

Attorney Docket No.:AUSP7209
WP1/WSW/AUSP/7209.001

8/24/89-7

message back to the sending processor. The reply message may be no more than the original command message unaltered, or it may be a modified version of that message or a completely new message. If the reply message is not identical to the original command message, then the receiving processor directly accesses the original sender's shared memory to modify the original command message or overwrite it completely. For replies from the FC 112a to the NC 110a, this involves an ordinary VME block or non-block mode transfer from the FC 112a, via buffer 384, VME bus 120, buffer 284 and into NC CPU memory 214. Again, the FC microprocessor 310 directly accesses NC CPU memory 214 for this purpose over the VME bus 120.

Whether or not the original command message has been changed, the receiving processor then writes a reply message descriptor directly into the original sender's command FIFO. The reply message descriptor contains the same VME address as the original command message descriptor, and the low order two bits of the word are modified to indicate that this is a reply message. For replies from the FC 112a to the NC 110a, the message descriptor write is accomplished by microprocessor 310 directly accessing command FIFO 290 via buffer 384, VME bus 120 and buffer 280 on the NC. Once this is done, the receiving processor can free the

buffer in its local memory containing the copy of the command message.

5 When the original sending processor reaches the reply message descriptor on its command FIFO, it wakes up the process that originally sent the message and permits it to continue. After examining the reply message, the original sending processor can free the original command message buffer in its own local shared memory.

10 As mentioned above, network controller 110a uses the buffer 284 data path in order to write message descriptors onto the VME bus 120, and uses VME/FIFO DMA controller 272 together with parity FIFO 270 in order to copy messages from the VME bus 120 into CPU memory 15 214. Other processors read from CPU memory 214 using the buffer 284 data path.

File controller 112a writes message descriptors onto the VME bus 120 using the buffer 384 data path, and copies messages from other processors' shared 20 memory via the same data path. Both take place under the control of microprocessor 310. Other processors copy messages from CPU memory 314 also via the buffer 384 data path.

Storage processor 114a writes message descriptors 25 onto the VME bus using high-speed register 590 in the manner described above, and copies messages from other

processors using DMA controller 580 and FIFO 554. The
SP 114a has no shared memory, however, so it uses a
buffer in system memory 116 to emulate that function.
That is, before it writes a message descriptor into
5 another processor's command FIFO, the SP 114a first
copies the message into its own previously allocated
buffer in system memory 116 using DMA controller 580
and FIFO 554. The VME address included in the message
descriptor then reflects the VME address of the message
10 in system memory 116.

In the host 118, the command FIFO and shared
memory are both emulated in software.

The invention has been described with respect to
particular embodiments thereof, and it will be
15 understood that numerous modifications and variations
are possible within the scope of the invention.

APPENDIX A

VME/FIFO DMA Controller

In storage processor 114a, DMA controller 580 manages the data path under the direction of the microprocessor 510. The DMA controller 580 is a microcoded 16-bit bit-slice implementation executing pipelined instructions at a rate of one each 62.5ns. It is responsible for scanning the channel status 562 and servicing request with parameters stored in the dual-ported ram 584 by the microprocessor 510. Ending status is returned in the ram 584 and interrupts are generated for the microprocessor 510.

Control Store. The control store contains the microcoded instructions which control the DMA controller 580. The control store consists of 6 1K x 8 proms configured to yield a 1K x 48 bit microword. Locations within the control store are addressed by the sequencer and data is presented at the input of the pipeline registers.

Sequencer. The sequencer controls program flow by generating control store addresses based upon pipeline data and various status bits. The control store address consists of 10 bits. Bits 8:0 of the control store address derive from a multiplexer having as its inputs either an ALU output or the output of an incrementer. The incrementer can be preloaded with

pipeline register bits 8:0, or it can be incremented as
a result of a test condition. The 1K address range is
divided into two pages by a latched flag such that the
microprogram can execute from either page. Branches,
5 however remain within the selected page. Conditional
sequencing is performed by having the test condition
increment the pipeline provided address. A false
condition allows execution from the pipeline address
while a true condition causes execution from the
10 address + 1. The alu output is selected as an address
source in order to directly vector to a routine or in
order to return to a calling routine. Note that when
calling a subroutine the calling routine must reside
within the same page as the subroutine or the wrong
15 page will be selected on the return.

ALU. The alu comprises a single IDT49C402A
integrated circuit. It is 16 bits in width and most
closely resembles four 2901s with 64 registers. The alu
is used primarily for incrementing, decrementing,
20 addition and bit manipulation. All necessary control
signals originate in the control store. The IDT HIGH
PERFORMANCE CMOS 1988 DATA BOOK, incorporated by
reference herein, contains additional information about
the alu.

25 Microword. The 48 bit microword comprises
several fields which control various functions of the

DMA controller 580. The format of the microword is defined below along with mnemonics and a description of each function.

- 5 AI<8:0> 47:39 (Alu Instruction bits 8:0) The AI bits provide the instruction for the 49C402A alu. Refer to the IDT data book for a complete definition of the alu instructions. Note that the I9 signal input of the 49C402A is always low.
- 10 CIN 38 (Carry INput) This bit forces the carry input to the alu.
- 15 RA<5:0> 37:32 (Register A address bits 5:0) These bits select one of 64 registers as the "A" operand for the alu. These bits also provide literal bits 15:10 for the alu bus.
- 20 RB<5:0> 31:26 (Register B address bits 5:0) These bits select one of 64 registers as the "B" operand for the alu. These bits also provide literal bits 9:4 for the alu bus.
- 25 LFD 25 (Latched Flag Data) When set this bit causes the selected latched flag to be set. When reset this bit causes the selected latched flag to be cleared. This bits also functions as literal bit 3 for the alu bus.
- 30 LFS<2:0> 24:22 (Latched Flag Select bits 2:0) The meaning of these bits is dependent upon the selected source for the alu bus. In the event that the literal field is selected as the bus source then LFS<2:0> function as literal bits <2:0> otherwise the bits are used to select one of the latched flags.
- 35

LFS<2:0> SELECTED FLAG

- 0 This value selects a null flag.
- 5 1 When set this bit enables the buffer clock. When reset this bit disables the buffer clock.
- 10 2 When this bit is cleared VME bus transfers, buffer operations and RAS are all disabled.
- 15 3 NOT USED
- 4 When set this bit enables VME bus transfers.
- 20 5 When set this bit enables buffer operations.
- 25 6 When set this bit asserts the row address strobe to the dram buffer.
- 7 When set this bit selects page 0 of the control store.
- 30 SRC<1,0> 20,21 (alu bus SouRcE select bits 1,0) These bits select the data source to be enabled onto the alu bus.

SRC<1,0> Selected Source

- 35 0 alu
- 1 dual ported ram
- 2 literal
- 3 reserved-not defined
- 40 PF<2:0> 19:17 (Pulsed Flag select bits 2:0) These bits select a flag/signal to be pulsed.

	<u>PF<2:0></u>	<u>Flag</u>
	0	null
5	1	SGL_CLK generates a single transition of buffer clock.
10	2	SET_VB forces vme and buffer enable to be set.
15	3	CL_PERR clears buffer parity error status.
20	4	SET_DN set channel done status for the currently selected channel.
25	5	INC_ADR increment dual ported ram address.
	6:7	RESERVED - NOT DEFINED

DEST<3:0> 16:13 (DESTination select bits 3:0) These bits select one of 10 destinations to be loaded from the alu bus.

	<u>DEST<3:0></u>	<u>Destination</u>
	0	null
35	1	WR_RAM causes the data on the alu bus to be written to the dual ported ram. D<15:0> -> ram<15:0>
40	2	WR_BADD loads the data from the alu bus into the dram address counters. D<14:7> -> mux addr<8:0>
45		

3 WR_VADL
loads the data from the alu
bus into the least significant
2 bytes of the VME address
5 register.
D<15:2> -> VME addr<15:2>
D1 -> ENB_ENH
D0 -> ENB_BLK

10 4 WR_VADH
loads the most significant 2
bytes of the VME address
register.
15 D<15:0> -> VME addr<31:16>

20 5 WR_RADD
loads the dual ported ram
address counters.
25 D<10:0> -> ram addr <10:0>

30 6 WR_WCNT
loads the word counters.
D15 -> count enable*
25 D<14:8> -> count <6:0>

35 7 WR_CO
loads the co-channel select
register.
30 D<7:4> -> CO<3:0>

40 8 WR_NXT
loads the next-channel select
register.
35 D<3:0> -> NEXT<3:0>

45 9 WR_CUR
loads the current-channel
select register.
40 D<3:0> -> CURR <3:0>

10:14 RESERVED - NOT DEFINED

15 JUMP
causes the control store
sequencer to select the alu
data bus.
45 D<8:0> -> CS_A<8:0>

TEST<3:0> 12:9 (TEST condition select bits 3:0) Select one of 16 inputs to the test multiplexor to be used as the carry input to the incrementer.

5

TEST<3:0> Condition

	0	FALSE	-always false
	1	TRUE	-always true
10	2	ALU_COUT	-carry output of alu
	3	ALU_EQ	-equals output of alu
15	4	ALU_OVR	-alu overflow
	5	ALU_NEG	-alu negative
20	6	XFR_DONE	-transfer complete
	7	PAR_ERR	-buffer parity error
	8	TIMOUT	-bus operation timeout
25	9	ANY_ERR	-any error status
	14:10	RESERVED	-NOT DEFINED
30	15	CH_RDY	-next channel ready

NEXT_A<8:0> 8:0 (NEXT Address bits 8:0) Selects an instructions from the current page of the control store for execution.

Dual Ported Ram. The dual ported ram is the medium by which command, parameters and status are communicated between the DMA controller 580 and the microprocessor 510. The ram is organized as 1K x 32 at the master port and as 2K x 16 at the DMA port. The ram may be both written and read at either port.

The ram is addressed by the DMA controller 580 by loading an 11 bit address into the address counters.

Data is then read into bidirectional registers and the address counter is incremented to allow read of the next location.

5 Writing the ram is accomplished by loading data from the processor into the registers after loading the ram address. Successive writes may be performed on every other processor cycle.

10 The ram contains current block pointers, ending status, high speed bus address and parameter blocks. The following is the format of the ram:

OFFSET	31	0
	0	{ CURR POINTER 0 STATUS 0 }
5	4	{ INITIAL POINTER 0 }
10	58	{ CURR POINTER B STATUS B }
	5C	{ INITIAL POINTER B }
15	60	{ not used not used }
	64	{ not used not used }
	68	{ CURR POINTER D STATUS D }
20	6C	{ INITIAL POINTER D }
	70	{ not used STATUS E }
25	74	{ HIGH SPEED BUS ADDRESS 31:2 0 0 }
	78	{ PARAMETER BLOCK 0 }
30	??	{ PARAMETER BLOCK n }

The Initial Pointer is a 32 bit value which points
35 the first command block of a chain. The current pointer
is a sixteen bit value used by the DMA controller 580
to point to the current command block. The current
command block pointer should be initialized to 0x0000
by the microprocessor 510 before enabling the channel.
40 Upon detecting a value of 0x0000 in the current block
pointer the DMA controller 580 will copy the lower 16
bits from the initial pointer to the current pointer.
Once the DMA controller 580 has completed the specified

Attorney Docket No.:AUSP7209
WP1/WSW/AUSP/7209.001

8/24/89-7

operations for the parameter block the current pointer will be updated to point to the next block. In the event that no further parameter blocks are available the pointer will be set to 0x0000.

5 The status byte indicates the ending status for the last channel operation performed. The following status bytes are defined:

	<u>STATUS</u>	<u>MEANING</u>
	0	NO ERRORS
10	1	ILLEGAL OP CODE
	2	BUS OPERATION TIMEOUT
	3	BUS OPERATION ERROR
	4	DATA PATH PARITY ERROR

The format of the parameter block is:

15	OFFSET	31		0
	0	FORWARD LINK		
20	4	NOT USED	WORD COUNT	
	8	VME ADDRESS 31:2, ENH, BLK		
	C	TERM 0	OP 0	BUF ADDR 0
25		. . .		
30	C+(4Xn)	TERM n	OP n	BUF ADDR n

FORWARD LINK - The forward link points to the first word of the next parameter block for execution.
35 It allows several parameter blocks to be initialized

and chained to create a sequence of operations for execution. The forward pointer has the following format:

A31:A2,0,0

5 The format dictates that the parameter block must start on a quad byte boundary. A pointer of 0x00000000 is a special case which indicates no forward link exists.

WORD COUNT - The word count specifies the number of quad byte words that are to be transferred to or
10 from each buffer address or to/from the VME address. A word count of 64K words may be specified by initializing the word count with the value of 0. The word count has the following format:

{D15|D14|D13|D12|D11|D10|D9|D8|D7|D6|D5|D4|D3|D2|D1|D0|

15 The word count is updated by the DMA controller 580 at the completion of a transfer to/from the last specified buffer address. Word count is not updated after transferring to/from each buffer address and is therefore not an accurate indicator of the total data
20 moved to/from the buffer. Word count represents the amount of data transferred to the VME bus or one of the FIFOs 544 or 554.

VME ADDRESS - The VME address specifies the starting address for data transfers. Thirty bits allows
25 the address to start at any quad byte boundary.

ENH - This bit when set selects the enhanced block transfer protocol described in the above-cited ENHANCED VMEBUS PROTOCOL UTILIZING PSEUDOSYNCHRONOUS HANDSHAKING AND BLOCK MODE DATA TRANSFER application, to be used during the VME bus transfer. Enhanced protocol will be disabled automatically when performing any transfer to or from 24 bit or 16 bit address space, when the starting address is not 8 byte aligned or when the word count is not even.

10 BLK - This bit when set selects the conventional VME block mode protocol to be used during the VME bus transfer. Block mode will be disabled automatically when performing any transfer to or from 16 bit address space.

15 BUF ADDR - The buffer address specifies the starting buffer address for the adjacent operation. Only 16 bits are available for a 1M byte buffer and as a result the starting address always falls on a 16 byte boundary. The programmer must ensure that the starting address is on a modulo 128 byte boundary. The buffer address is updated by the DMA controller 580 after completion of each data burst.

{A19|A18|A17|A16|A15|A14|A13|A12|A11|A10|A9|A8|A7|A6|A5|A4|

25 TERM - The last buffer address and operation within a parameter block is identified by the terminal bit. The DMA controller 580 continues to fetch buffer

addresses and operations to perform until this bit is encountered. Once the last operation within the parameter block is executed the word counter is updated and if not equal to zero the series of operations is repeated. Once the word counter reaches zero the forward link pointer is used to access the next parameter block.

5

|0|0|0|0|0|0|0|0|0|T|

10

OP - Operations are specified by the op code. The op code byte has the following format:

|0|0|0|0|OP3|OP2|OP1|OP0|

The op codes are listed below ("FIFO" refers to any of the FIFOs 544 or 554):

	<u>OP CODE</u>	<u>OPERATION</u>
	0	NO-OP
	1	ZEROES -> BUFFER
	2	ZEROES -> FIFO
5	3	ZEROES -> VMEbus
	4	VMEbus -> BUFFER
	5	VMEbus -> FIFO
	6	VMEbus -> BUFFER & FIFO
	7	BUFFER -> VMEbus
10	8	BUFFER -> FIFO
	9	FIFO -> VMEbus
	A	FIFO -> BUFFER
	B	FIFO -> VMEbus & BUFFER
	C	RESERVED
15	D	RESERVED
	E	RESERVED
	F	RESERVED

Attorney Docket No.:AUSP7209
WP1/WSW/AUSP/7209.001

8/24/89-7

APPENDIX B

Enhanced VME Block Transfer Protocol

The enhanced VME block transfer protocol is a VMEbus compatible pseudo-synchronous fast transfer handshake protocol for use on a VME backplane bus having a master functional module and a slave functional module logically interconnected by a data transfer bus. The data transfer bus includes a data strobe signal line and a data transfer acknowledge signal line. To accomplish the handshake, the master transmits a data strobe signal of a given duration on the data strobe line. The master then awaits the reception of a data transfer acknowledge signal from the slave module on the data transfer acknowledge signal line. The slave then responds by transmitting data transfer acknowledge signal of a given duration on the data transfer acknowledge signal line.

Consistent with the pseudo-synchronous nature of the handshake protocol, the data to be transferred is referenced to only one signal depending upon whether the transfer operation is a READ or WRITE operation. In transferring data from the master functional unit to the slave, the master broadcasts the data to be transferred. The master asserts a data strobe signal and the slave, in response to the data strobe signal, captures the data broadcast by the master. Similarly,

in transferring data from the slave to the master, the slave broadcasts the data to be transferred to the master unit. The slave then asserts a data transfer acknowledge signal and the master, in response to the data transfer acknowledge signal, captures the data broadcast by the slave.

The fast transfer protocol, while not essential to the present invention, facilitates the rapid transfer of large amounts of data across a VME backplane bus by substantially increasing the data transfer rate. These data rates are achieved by using a handshake wherein the data strobe and data transfer acknowledge signals are functionally decoupled and by specifying high current drivers for all data and control lines.

The enhanced pseudo-synchronous method of data transfer (hereinafter referred to as "fast transfer mode") is implemented so as to comply and be compatible with the IEEE VME backplane bus standard. The protocol utilizes user-defined address modifiers, defined in the VMEbus standard, to indicate use of the fast transfer mode. Conventional VMEbus functional units, capable only of implementing standard VMEbus protocols, will ignore transfers made using the fast transfer mode and, as a result, are fully compatible with functional units capable of implementing the fast transfer mode.

The fast transfer mode reduces the number of bus propagations required to accomplish a handshake from four propagations, as required under conventional VMEbus protocols, to only two bus propagations.

5 Likewise, the number of bus propagations required to effect a BLOCK READ or BLOCK WRITE data transfer is reduced. Consequently, by reducing the propagations across the VMEbus to accomplish handshaking and data transfer functions, the transfer rate is materially
10 increased.

The enhanced protocol is described in detail in the above-cited ENHANCED VMEBUS PROTOCOL application, and will only be summarized here. Familiarity with the conventional VME bus standards is assumed.

15 In the fast transfer mode handshake protocol, only two bus propagations are used to accomplish a handshake, rather than four as required by the conventional protocol. At the initiation of a data transfer cycle, the master will assert and deassert
20 DS0* in the form of a pulse of a given duration. The deassertion of DS0* is accomplished without regard as to whether a response has been received from the slave. The master then waits for an acknowledgement from the slave. Subsequent pulsing of DS0* cannot occur until a
25 responsive DTACK* signal is received from the slave. Upon receiving the slave's assertion of DTACK*, the

master can then immediately reassert data strobe, if so
desired. The fast transfer mode protocol does not
require the master to wait for the deassertion of
DTACK* by the slave as a condition precedent to
5 subsequent assertions of DS0*. In the fast transfer
mode, only the leading edge (i.e., the assertion) of a
signal is significant. Thus, the deassertion of either
DS0* or DTACK* is completely irrelevant for completion
of a handshake. The fast transfer protocol does not
10 employ the DS1* line for data strobe purposes at all.

The fast transfer mode protocol may be
characterized as pseudo-synchronous as it includes both
synchronous and asynchronous aspects. The fast
transfer mode protocol is synchronous in character due
15 to the fact that DS0* is asserted and deasserted
without regard to a response from the slave. The
asynchronous aspect of the fast transfer mode protocol
is attributable to the fact that the master may not
subsequently assert DS0* until a response to the prior
20 strobe is received from the slave. Consequently,
because the protocol includes both synchronous and
asynchronous components, it is most accurately
classified as "pseudo-synchronous."

The transfer of data during a BLOCK WRITE cycle in
25 the fast transfer protocol is referenced only to DS0*.
The master first broadcasts valid data to the slave,

and then asserts DS0 to the slave. The slave is given a predetermined period of time after the assertion of DS0* in which to capture the data. Hence, slave modules must be prepared to capture data at any time, as DTACK* is not referenced during the transfer cycle.

Similarly, the transfer of data during a BLOCK READ cycle in the fast transfer protocol is referenced only to DTACK*. The master first asserts DS0*. The slave then broadcasts data to the master and then asserts DTACK*. The master is given a predetermined period of time after the assertion of DTACK in which to capture the data. Hence, master modules must be prepared to capture data at any time as DS0 is not referenced during the transfer cycle.

Fig. 7, parts A through C, is a flowchart illustrating the operations involved in accomplishing the fast transfer protocol BLOCK WRITE cycle. To initiate a BLOCK WRITE cycle, the master broadcasts the memory address of the data to be transferred and the address modifier across the DTB bus. The master also drives interrupt acknowledge signal (IACK*) high and the LWORD* signal low 701. A special address modifier, for example "1F," broadcast by the master indicates to the slave module that the fast transfer protocol will be used to accomplish the BLOCK WRITE.

The starting memory address of the data to be

transferred should reside on a 64-bit boundary and the size of block of data to be transferred should be a multiple of 64 bits. In order to remain in compliance with the VMEbus standard, the block must not cross a
5 256 byte boundary without performing a new address cycle.

The slave modules connected to the DTB receive the address and the address modifier broadcast by the master across the bus and receive LWORD* low and IACK*
10 high 703. Shortly after broadcasting the address and address modifier 701, the master drives the AS* signal low 705. The slave modules receive the AS* low signal 707. Each slave individually determines whether it will participate in the data transfer by determining
15 whether the broadcasted address is valid for the slave in question 709. If the address is not valid, the data transfer does not involve that particular slave and it ignores the remainder of the data transfer cycle.

The master drives WRITE* low to indicate that the transfer cycle about to occur is a WRITE operation 711.
20 The slave receives the WRITE* low signal 713 and, knowing that the data transfer operation is a WRITE operation, awaits receipt of a high to low transition on the DS0* signal line 715. The master will wait
25 until both DTACK* and BERR* are high 718, which

indicates that the previous slave is no longer driving the DTB.

5 The master proceeds to place the first segment of the data to be transferred on data lines D00 through D31, 719. After placing data on D00 through D31, the master drives DS0* low 721 and, after a predetermined interval, drives DS0* high 723.

10 In response to the transition of DS0* from high to low, respectively 721 and 723, the slave latches the data being transmitted by the master over data lines D00 through D31, 725. The master places the next segment of the data to be transferred on data lines D00 through D31, 727, and awaits receipt of a DTACK* signal in the form of a high to low transition signal, 729 in
15 Fig. 7B.

Referring to Fig. 7B, the slave then drives DTACK* low, 731, and, after a predetermined period of time, drives DTACK high, 733. The data latched by the slave, 725, is written to a device, which has been selected to
20 store the data 735. The slave also increments the device address 735. The slave then waits for another transition of DS0* from high to low 737.

To commence the transfer of the next segment of the block of data to be transferred, the master drives
25 DS0* low 739 and, after a predetermined period of time, drives DS0* high 741. In response to the

transition of DS0* from high to low, respectively 739
and 741, the slave latches the data being broadcast by
the master over data lines D00 through D31, 743. The
master places the next segment of the data to be
5 transferred on data lines D00 through D31, 745, and
awaits receipt of a DTACK* signal in the form of a high
to low transition, 747.

The slave then drives DTACK* low, 749, and, after
a predetermined period of time, drives DTACK* high,
10 751. The data latched by the slave, 743, is written to
the device selected to store the data and the device
address is incremented 753. The slave waits for
another transition of DS0* from high to low 737.

The transfer of data will continue in the above-
15 described manner until all of the data has been
transferred from the master to the slave. After all of
the data has been transferred, the master will release
the address lines, address modifier lines, data lines,
IACK* line, LWORD* line and DS0* line, 755. The
20 master will then wait for receipt of a DTACK* high to
low transition 757. The slave will drive DTACK* low,
759 and, after a predetermined period of time, drive
DTACK* high 761. In response to the receipt of the
DTACK* high to low transition, the master will drive
25 AS* high 763 and then release the AS* line 765.

Fig. 8, parts A through C, is a flowchart illustrating the operations involved in accomplishing the fast transfer protocol BLOCK READ cycle. To initiate a BLOCK READ cycle, the master broadcasts the memory address of the data to be transferred and the address modifier across the DTB bus 801. The master drives the LWORD* signal low and the IACK* signal high 801. As noted previously, a special address modifier indicates to the slave module that the fast transfer protocol will be used to accomplish the BLOCK READ.

The slave modules connected to the DTB receive the address and the address modifier broadcast by the master across the bus and receive LWORD* low and IACK* high 803. Shortly after broadcasting the address and address modifier 801, the master drives the AS* signal low 805. The slave modules receive the AS* low signal 807. Each slave individually determines whether it will participate in the data transfer by determining whether the broadcasted address is valid for the slave in question 809. If the address is not valid, the data transfer does not involve that particular slave and it ignores the remainder of the data transfer cycle.

The master drives WRITE* high to indicate that the transfer cycle about to occur is a READ operation 811. The slave receives the WRITE* high signal 813 and, knowing that the data transfer operation is a READ

operation, places the first segment of the data to be transferred on data lines D00 through D31 819. The master will wait until both DTACK* and BERR* are high 818, which indicates that the previous slave is no longer driving the DTB.

The master then drives DS0* low 821 and, after a predetermined interval, drives DS0* high 823. The master then awaits a high to low transition on the DTACK* signal line 824. As shown in Fig. 8B, the slave then drives the DTACK* signal low 825 and, after a predetermined period of time, drives the DTACK* signal high 827.

In response to the transition of DTACK* from high to low, respectively 825 and 827, the master latches the data being transmitted by the slave over data lines D00 through D31, 831. The data latched by the master, 831, is written to a device, which has been selected to store the data the device address is incremented 833.

The slave places the next segment of the data to be transferred on data lines D00 through D31, 829, and then waits for another transition of DS0* from high to low 835.

To commence the transfer of the next segment of the block of data to be transferred, the master drives DS0* low 839 and, after a predetermined period of

time, drives DS0* high 841. The master then waits for the DTACK* line to transition from high to low, 843.

The slave drives DTACK* low, 845, and, after a predetermined period of time, drives DTACK* high, 847.

5 In response to the transition of DTACK* from high to low, respectively 839 and 841, the master latches the data being transmitted by the slave over data lines D00 through D31, 845. The data latched by the master, 845, is written to the device selected to store the data, 10 851 in Fig. 8C, and the device address is incremented. The slave places the next segment of the data to be transferred on data lines D00 through D31, 849.

The transfer of data will continue in the above-described manner until all of the data to be 15 transferred from the slave to the master has been written into the device selected to store the data. After all of the data to be transferred has been written into the storage device, the master will release the address lines, address modifier lines, data 20 lines, the IACK* line, the LWORD line and DS0* line 852. The master will then wait for receipt of a DTACK* high to low transition 853. The slave will drive DTACK* low 855 and, after a predetermined period of time, drive DTACK* high 857. In response to the 25 receipt of the DTACK* high to low transition, the

master will drive AS* high 859 and release the AS* line
861.

To implement the fast transfer protocol, a
conventional 64 mA tri-state driver is substituted for
5 the 48 mA open collector driver conventionally used in
VME slave modules to drive DTACK*. Similarly, the
conventional VMEbus data drivers are replaced with 64
mA tri-state drivers in SO-type packages. The latter
modification reduces the ground lead inductance of the
10 actual driver package itself and, thus, reduces "ground
bounce" effects which contribute to skew between data,
DS0* and DTACK*. In addition, signal return inductance
along the bus backplane is reduced by using a connector
system having a greater number of ground pins so as to
15 minimize signal return and mated-pair pin inductance.
One such connector system is the "High Density Plus"
connector, Model No. 420-8015-000, manufactured by
Teradyne Corporation.

APPENDIX C

Parity FIFO

5 The parity FIFOs 240, 260 and 270 (on the network
controllers 110), and 544 and 554 (on storage
processors 114) are each implemented as an ASIC. All
the parity FIFOs are identical, and are configured on
power-up or during normal operation for the particular
function desired. The parity FIFO is designed to allow
speed matching between buses of different speed, and
10 to perform the parity generation and correction for
the parallel SCSI drives.

The FIFO comprises two bidirectional data ports,
Port A and Port B, with 36 x 64 bits of RAM buffer
between them. Port A is 8 bits wide and Port B is 32
15 bits wide. The RAM buffer is divided into two parts,
each 36 x 32 bits, designated RAM X and RAM Y. The two
ports access different halves of the buffer alternating
to the other half when available. When the chip is
configured as a parallel parity chip (e.g. one of the
20 FIFOs 544 on SP 114a), all accesses on Port B are
monitored and parity is accumulated in RAM X and RAM Y
alternately.

The chip also has a CPU interface, which may be 8
or 16 bits wide. In 16 bit mode the Port A pins are
25 used as the most significant data bits of the CPU

interface and are only actually used when reading or writing to the Fifo Data Register inside the chip.

5 A REQ, ACK handshake is used for data transfer on both Ports A and B. The chip may be configured as either a master or a slave on Port A in the sense that, in master mode the Port A ACK / RDY output signifies that the chip is ready to transfer data on Port A, and the Port A REQ input specifies that the slave is responding. In slave mode, however, the Port A REQ 10 input specifies that the master requires a data transfer, and the chip responds with Port A ACK / RDY when data is available. The chip is a master on Port B since it raises Port B REQ and waits for Port B ACK to indicate completion of the data transfer.

15 SIGNAL DESCRIPTIONS

Port A 0-7, P

Port A is the 8 bit data port. Port A P, if used, is the odd parity bit for this port.

A Req, A Ack/Rdy

20 These two signals are used in the data transfer mode to control the handshake of data on Port A.