



US006425035C1

(12) **EX PARTE REEXAMINATION CERTIFICATE** (5472nd)
United States Patent
Hoese et al.

(10) Number: **US 6,425,035 C1**
(45) Certificate Issued: ***Aug. 8, 2006**

- (54) **STORAGE ROUTER AND METHOD FOR PROVIDING VIRTUAL LOCAL STORAGE**
- (75) Inventors: **Geoffrey H. Hoese**, Austin, TX (US);
Jeffry T. Russell, Cibolo, TX (US)
- (73) Assignee: **Crossworlds Software**, Burlingame, CA (US)

- 4,864,532 A 9/1989 Reeve et al.
- 4,947,367 A 8/1990 Chang et al.
- 5,072,378 A 12/1991 Manka
- 5,163,131 A 11/1992 Row et al.
- 5,239,632 A 8/1993 Lamer
- 5,239,643 A 8/1993 Blount et al.

(Continued)

Reexamination Request:

- No. 90/007,125, Jul. 19, 2004
- No. 90/007,317, Nov. 23, 2004

Reexamination Certificate for:

- Patent No.: **6,425,035**
- Issued: **Jul. 23, 2002**
- Appl. No.: **09/965,335**
- Filed: **Sep. 27, 2001**

- (*) Notice: This patent is subject to a terminal disclaimer.

Related U.S. Application Data

- (63) Continuation of application No. 09/354,682, filed on Jul. 15, 1999, now Pat. No. 6,421,753, which is a continuation of application No. 09/001,799, filed on Dec. 31, 1997, now Pat. No. 5,941,972.

- (51) **Int. Cl.**
G06F 13/00 (2006.01)

- (52) **U.S. Cl.** **710/315; 710/2; 710/8; 710/36; 710/105; 710/305; 710/308; 711/112**

- (58) **Field of Classification Search** **710/1-5, 710/8-13, 36-38, 105, 100, 101, 305-316; 711/100, 112, 113; 714/42**

See application file for complete search history.

(56) **References Cited**

U.S. PATENT DOCUMENTS

- 3,082,406 A 3/1963 Stevens
- 4,092,732 A 5/1978 Ouchi
- 4,695,948 A 9/1987 Blevins et al.
- 4,751,635 A 6/1988 Kret

FOREIGN PATENT DOCUMENTS

- EP 0810530 A2 12/1997
- EP 0827059 A2 3/1998
- GB 2296798 A 7/1996
- GB 2297636 A 8/1996
- GB 2341715 3/2000
- JP 6301607 10/1994
- JP 8-230895 9/1996
- WO WO 98/36357 8/1998
- WO WO 99/34297 A1 7/1999

OTHER PUBLICATIONS

Systems Architectures Using Fibre Channel, Roger Cummings, Twelfth IEE Symposium on Mass Storage Systems, copyright 1993 IEEE. pp. 251-256.*

(Continued)

Primary Examiner—Dov Popovici

(57) **ABSTRACT**

A storage router (56) and storage network (50) provide virtual local storage on remote SCSI storage devices (60, 62, 64) to Fiber Channel devices (60, 62, 64) to Fiber Channel devices. A plurality of Fiber Channel devices, such as workstations (58), are connected to a Fiber Channel transport medium (52), and a plurality of SCSI storage devices (60, 62, 64) are connected to a SCSI bus transport medium (54). The storage router (56) interfaces between the Fibre Channel transport medium (52) and the SCSI bus transport medium (54). The storage router (56) maps between the workstations (58) and the SCSI storage devices (60, 62, 64) and implements access, controls for storage space on the SCSI storage devices (60, 62, 64). The storage router (56) then allows access from the workstations (58) to the SCSI storage devices (60, 62, 64) using native low level, block protocol in accordance with the mapping and the access controls.

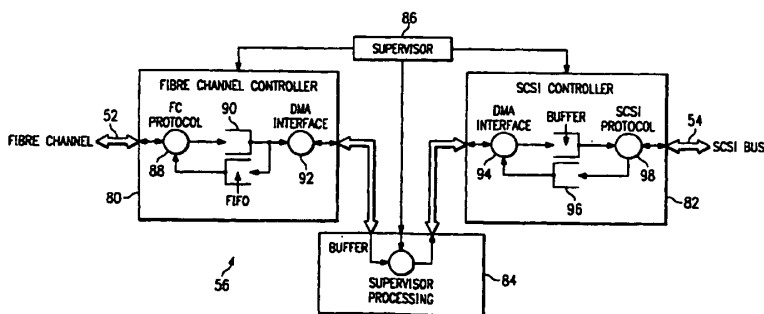

U.S. PATENT DOCUMENTS

5,257,386	A	10/1993	Saito	
5,345,565	A *	9/1994	Jibbe et al.	710/316
5,347,384	A	9/1994	McReynolds et al.	
5,394,526	A *	2/1995	Crouse et al.	709/219
5,414,820	A	5/1995	McFarland et al.	
5,423,044	A	6/1995	Sutton et al.	
5,465,382	A	11/1995	Day, III et al.	
5,530,845	A	6/1996	Hiatt et al.	
5,535,352	A	7/1996	Bridges et al.	
5,581,714	A	12/1996	Amini et al.	
5,596,562	A	1/1997	Chen	
5,596,736	A	1/1997	Kerns	
5,598,541	A	1/1997	Malladi	
5,634,111	A *	5/1997	Oeda et al.	711/153
5,680,556	A	10/1997	Begun et al.	
5,701,491	A	12/1997	Dunn et al.	
5,712,976	A	1/1998	Falcon et al.	
5,729,705	A	3/1998	Weber	
5,743,847	A	4/1998	Nakamura et al.	
5,751,975	A	5/1998	Gillespie et al.	
5,774,683	A	6/1998	Gulick	
5,845,107	A	12/1998	Fisch et al.	
5,857,080	A	1/1999	Jander et al.	
5,864,653	A	1/1999	Tavallaei et al.	
5,867,648	A	2/1999	Foth et al.	
5,884,027	A	3/1999	Garbus et al.	
5,913,045	A	6/1999	Gillespie et al.	
5,923,557	A	7/1999	Eidson	
5,941,969	A	8/1999	Ram et al.	
5,953,511	A	9/1999	Sescilia et al.	
5,959,994	A	9/1999	Boggs et al.	
5,974,530	A	10/1999	Young	
5,978,379	A	11/1999	Chan et al.	
5,991,797	A	11/1999	Futral et al.	
6,000,020	A	12/1999	Chin et al.	
6,021,451	A	2/2000	Bell et al.	
6,070,253	A	5/2000	Tavallaei et al.	
6,131,119	A	10/2000	Fukui	
6,134,617	A	10/2000	Weber	
6,141,737	A	10/2000	Krantz et al.	
6,145,006	A	11/2000	Vishlitsky et al.	
6,223,266	B1	4/2001	Sartore	
6,230,218	B1	5/2001	Casper et al.	
6,260,120	B1	7/2001	Blumenau et al.	
6,330,629	B1	12/2001	Kondo et al.	
6,363,462	B1	3/2002	Bergsten	
6,421,753	B1	7/2002	Hoese et al.	
6,425,035	B1	7/2002	Hoese et al.	
6,425,036	B1	7/2002	Hoese et al.	
6,484,245	B1	11/2002	Sanada et al.	
6,529,996	B1	3/2003	Nguyen et al.	

OTHER PUBLICATIONS

Fibre Channel and ATM: The Physical Layers, Jerry Quam, WESCON/94, published Sep. 27-29, 1994. pp. 648-652.*
 Petal: Distributed Virtual Disks, Edward K. Lee and Chandramohan A. Thekkath, ACM SIGPLAN Notices, vol. 31, Issue 9, Sep. 1996, pp. 84-92.*
 Black Box, SCSI Fiberoptic Extender, Single-Ended, Product Insert, 2 pages, 1996.
 Burskey, Dave "New Serial I/Os Speed Storage Subsystems" Feb. 6, 1996.
 CRD-5500, Raid Disk Array Controller Product Insert, pp. 1-5.
 CRD-5500, SCSI Raid Controller OEM Manual, Rev. 1.3, Feb. 26, 1996, pp. 1-54.

Raidtec FibreArray and Raidtec FlexArray UltraRaid Systems, Windows IT PRO Article, Oct. 1997.
 DIGITAL Storage Works, HSZ70 Array Controller, HSOF Version 7.0 EK-HSZ70-CG. A01, Digital Equipment Corporation, Maynard, Massachusetts.
 DIGITAL StorageWorks, Using Your HSZ70 Array Controller in a SCSI Controller Shelf (DS-BA356-M Series), User's Guide, pp. 1-1 through A-5 with index, Jan. 1998.
 DIGITAL StorageWorks HSZ270 Array Controller HSOF Version 7.0 EK-HSZ270-RM. A01. CLI Reference Manual.
 DIGITAL StorageWorks HSG80 Array Controller ACS Version 8.0 (User's Guide) Jan. 1998.
 DIGITAL StorageWorks HSZ70 Array Controller HSOF Version 7.0 EK-HSZ70-SV. A01.
 Emerson, "Ancor Communications: Performance evaluation of switched fibre channel I/O system using—FCP for SCSI" Feb. 1995, IEEE, pp. 479-484.
 IBM Technical Publication: Magstar and IBM 3590 High Performance Tape Subsystem Technical Guide, Nov. 1996, pp. 1-269.
 Guide to Sharing and Partitioning IBM Tape Library Dataservers, Nov. 1996, IBM, International Technical Support Organization, San Jose Center.
 Misc. Reference Manual Pages, SunOS 5.09.
 Block-Based Distributed File Systems, Anthony J. McGregor, Jul. 1997.
 InfoServer 150VXT Photograph.
 Pictures of internal components of the InfoServer 150, taken from <http://bindarydinosaurs.couk/Museum/Digital/Infoserver/infoserver.php> in Nov. 2004.
 Simplest Migration to Fibre Channel Technology.
 Compaq StorageWorks HSG80 Array Controller ACS Version 8.3 (Maintenance and Service Guide) Nov. 1998.
 Compaq StorageWorks HSG80 Array Controller ACS Version 8.3 (Configuration and CLI Reference Guide) Nov. 1998.
 Office Action dated Jan. 21, 2003 for 10/174,720.
 Office Action dated Feb. 27, 2001 for 09/354,682.
 Office Action dated Aug. 11, 2000 for 09/354,682.
 Office Action dated Dec. 16, 1999 for 09/354,682.
 Office Action dated Nov. 6, 2002, for 10/023,786.
 Office Action dated Jan. 21, 2003 for 10/081,110.
 Office Action dated Jan. 27, 2005 in 10/658,163.
 Office Action in Ex Parte Reexamination 90/007,127, mailed Feb. 7, 2005.
 Office Action in Ex Parte Reexamination 90/007,126, mailed Feb. 7, 2005.
 Office Action in Ex Parte Reexamination 90/007,124, mailed Feb. 7, 2005.
 Office Action in Ex Parte Reexamination 90/007,123, mailed Feb. 7, 2005.
 European Office Action issued Apr. 1, 2004 in Application No. 98966104.6-2413.
 Defendant's First Supplemental Trial Exhibit List, *Crossroads Systems, Inc., v. Chaparral Network Storage, Inc.*, C.A. No. A-00CA-217-SS (W.D. Tex. 2001), (CD-Rom).
 Defendant's Third Supplemental Trial Exhibit List, *Crossroads Systems, Inc. v. Pathlight Technology, Inc.*, C.A. No. A-00CA-248-SS (W.D. Tex. 2001) (CD-Rom).
 Defendant's Trial Exhibits, *Crossroads Systems, Inc. v. Pathlight Technology, Inc.*, C.A. No. A-00CA-248-SS (W.D. Tex. 2001), (CD-Rom).

- Defendants' Trial Exhibits, *Crossroads Systems, Inc., v. Chaparral Network Storage, Inc.*, C.A. No. A-00CA-217-SS (W.D. Tex. 2001) (CD-Rom).
 Defendant Chaparral Network Storage, Inc.'s First Supplemental Trial Exhibit List (D1 through D271) (CD-ROM Chaparral Exhibits ExList_Def), Sep. 2, 2001.
 Defendant Pathlight Technology Inc.'s Third Supplemental Trial Exhibit List (CD-ROM Pathlight Exhibits ExList_Def).
 Plaintiff's Fourth Amended Trail Exhibit List, *Crossroads Systems, Inc. v. Chaparral Network Storage, Inc.*, C.A. No. A-00CA-217-SS (W.D. Tex. 2001) (CD-Rom), Sep. 11, 2001.
 Plaintiff's Revised Trial Exhibit List, *Crossroads Systems, Inc. v. Pathlight Technology, Inc.*, C.A. No. A-00CA-248-SS (W.D. Tex. 2001). (CD-Rom).
 Plaintiff's Trial Exhibits, *Crossroads Systems, Inc. v. Chaparral Networks Storage, Inc.*, C.A. No. A-00CA-217-SS (W.D. Tex. 2001). (CD-Rom).
 Plaintiff's Fourth Amended Trail Exhibit List (CD-ROM Chaparral Exhibits ExList_Plaintiff), Sep. 11, 2001.
 Plaintiff's Revised Trail Exhibit List (CD-ROM Pathlight Exhibits ExList_Plaintiff).
 Trail Transcripts, *Crossroads Systems, Inc. v. Chaparral Network Storage, Inc.*, C.A. No. A-00CA-217-SS (W.D. Tex. 2001) (CD-Rom).
 Trail Transcripts, *Crossroads Systems, Inc. v. Pathlight Technology, Inc.*, C.A. No. A-00CA-248-SS (W.D. Tex. 2001). (CD-Rom).
 Trial Exhibits and Transcripts, *Crossroads v. Chaparral*, Civil Action No. A-00CA-21755, W.D. Tex. 2000 (CD-Rom and hard copy printouts).
 Snively, "Sun Microsystem Computer Corporation: Implementing a fibre optic channel SCSI transport" 1994 IEEE, Feb. 28, 1994, pp. 78-82.
 Datasheet for CrossPoint 4100 Fibre Channel to SCSI Router (Dedek Ex 41 (ANCT 117-120)) (CD-ROM Chaparral Exhibits D012).
 Symbios Logic—Software Interface Specification Series 3 SCSI RAID Controller Software Release 02.xx (Engelbrecht Ex 2 (LSI 1421-1658)) (CD-ROM Chaparral Exhibits D013), Dec. 3, 1997.
 Press Release—Symbios Logic to Demonstrate Strong Support for Fibre Channel at Fall Comdex (Engelbrecht 12 (LSI 2785-86)) (CD-ROM Chaparral Exhibits D016), Nov. 13, 1996.
 OEM Datasheet on the 3701 Controller (Engelbrecht 13 (LSI 01837-38)) (CD-ROM Chaparral Exhibits D017), Jun. 17, 1995.
 Nondisclosure Agreement Between Adaptec and Crossroads Dated Oct. 17, 1996 (Quisenberry Ex 25 (CRDS 8196)) (CD-ROM Chaparral Exhibits D020).
 Organizational Presentation on the External Storage Group (Lavan Ex 1 (CNS 182242-255)) (CD-ROM Chaparral Exhibits D021), Apr. 11, 1996.
 Bridge. C, Bridge Between SCSI-2 and SCSI-3 FCP (Fibre Channel Protocol) (CD-ROM Chaparral Exhibits P214).
 Bridge Phase II Architecture Presentation (Lavan Ex 2 (CNS 182287-295)) (CD-ROM Chaparral Exhibits D022), Apr. 12, 1996.
 Attendees/Action Items from Apr. 12, 1996 Meeting at BTC (Lavan Ex 3 (CNS 182241)) (CD-ROM Chaparral Exhibits D023), Apr. 12, 1996.
 Brooklyn Hardware Engineering Requirements Documents, Revision 1.4 (Lavan Ex 4 (CNS 178188-211)) (CD-ROM Chaparral Exhibits D024) by Pecone, May 26, 1996.
 Brooklyn Single-Ended SCSI RAID Bridge Controller Hardware OEM Manual, Revision 2.1 (Lavan Ex 5 (CNS 177169-191)) (CD-ROM Chaparral Exhibits D025), Mar. 21, 1996.
 Coronado Hardware Engineering Requirements Document, Revision 0.0 (Lavan Ex 7 (CNS 176917-932)). (CD-ROM Chaparral Exhibits D027) by O'Dell, Sep. 30, 1996.
 ESS/FPG Organization (Lavan Ex 8 (CNS 178639-652)) (CD-ROM Chaparral Exhibits D028), Dec. 6, 1996.
 Adaptec MCS ESS Presents: Intelligent External I/O Raid Controllers "Bridge" Strategy (Lavan Ex 9 (CNS 178606-638)). (CD-ROM Chaparral Exhibits D029), Feb. 6, 1996.
 AEC-7313 Fibre Channel Daughter Board (for Brooklyn) Engineering Specification, Revision 1.0 (Lavan Ex 10 (CNS 176830-850)) (CD-ROM Chaparral Exhibits D030), Feb. 27, 1997.
 Bill of Material (Lavan Ex 14 (CNS 177211-214)) (CD-ROM Chaparral Exhibits D034), Jul. 24, 1997.
 AEC-4412B, AEC-7412/B2 External RAID Controller Hardware OEM Manual, Revision 2.0 (Lavan Ex 15 (CNS 177082-123)) (CD-ROM Chaparral Exhibits D035), Jun. 27, 1997.
 Coronado II, AEC-7312A Fibre Channel Daughter (for Brooklyn) Hardware Specification, Revision 1.2 (Lavan Ex 16 (CNS 177192-210)) (CD-ROM Chaparral Exhibits D037) by Tom Yang, Jul. 18, 1997.
 AEC-4412B, AEC7412/3B External RAID Controller Hardware OEM Manual, Revision 3.0. (Lavan Ex 17 (CNS 177124-165)) (CD-ROM Chaparral Exhibits D036), Aug. 25, 1997.
 Memo Dated Aug. 15, 1997 to AEC-7312A Evaluation Unit Customers re: B001 Release Notes (Lavan Ex 18 (CNS 182878-879)) (CD-ROM Chaparral Exhibits D038), Aug. 15, 1997.
 Brooklyn Main Board (AES-0302) MES Schedule (Lavan Ex 19 (CNS 177759-763)) (CD-ROM Chaparral Exhibits D039), Feb. 11, 1997.
 News Release—Adaptec Adds Fibre Channel Option to its External RAID Controller Family (Lavan Ex 20 (CNS 182932-934)) (CD-ROM Chaparral Exhibits D040), May 6, 1997.
 AEC-4412B/7412B User's Guide, Rev. A (Lavan Ex 21) (CD-ROM Chaparral Exhibits D041), Jun. 19, 1995.
 Data Book—AIC-7895 PCI Bus Master Single Chip SCSI Host Adapter (Davies Ex 1 (CNS 182944-64)) (CD-ROM Chaparral Exhibits D046), May 21, 1996.
 Data Book—AIC-1160 Fibre Channel Host Adapter ASIC (Davies Ex 2 (CNS 181800-825)) (CD-ROM Chaparral Exhibits D047), Jun. 18, 1995.
 Viking RAID Software (Davies Ex 3 (CNS 180969-181026)) (CD-ROM Chaparral Exhibits D048), Jun. 18, 1995.
 Header File with Structure Definitions (Davies Ex 4 (CNS 180009-018)) (CD-ROM Chaparral Exhibits D049), Aug. 8, 1996.
 C++ SourceCode for the SCSI Command Handler (Davies Ex 5 (CNS 179136-168)) (CD-ROM Chaparral Exhibits D050), Aug. 8, 1996.
 Header File Data Structure (Davies Ex 6 (CNS 179997-180008)) (CD-ROM Chaparral Exhibits D051), Jan. 2, 1997.
 SCSI Command Handler (Davies Ex 7 (CNS 179676-719)) (CD-ROM Chaparral Exhibits D052), Jan. 2, 1997.

- Coronado: Fibre Channel to SCSI Intelligent RAID Controller Product Brief (Kalwitz Ex 1 (CNS 182804-805)) (CD-ROM Chaparral Exhibits D053).
- Bill of Material (Kalwitz Ex 2 (CNS 181632-633)) (CD-ROM Chaparral Exhibits D054), Mar. 17, 1997.
- Emails Dated Jan. 13-Mar. 31, 1997 from P. Collins to Mo re: Status Reports (Kalwitz Ex 3 (CNS 182501-511)) (CD-ROM Chaparral Exhibits D055).
- Hardware Schematics for the Fibre Channel Daughtercard Coronado (Kalwitz Ex 4 (CNS 181639-648)) (CD-ROM Chaparral Exhibits D056).
- Adaptec Schematics re AAC-340 (Kalwitz Ex 14 CNS 177215-251)) (CD-ROM Chaparral Exhibits D057).
- Bridge Product Line Review (Manzanares Ex 3 (CNS 177307-336)) (CD-ROM Chaparral Exhibits D058).
- AEC Bridge Series Products-Adaptec External Controller RAID Products Pre-Release Draft, v.6 (Manzanares Ex 4 (CNS 174632-653)). (CD-ROM Chaparral Exhibits D059), Oct. 28, 1997.
- Hewlett-Packard Roseville Site Property Pass for Brian Smith (Dunning Ex 14 (HP 489)) (CD-ROM Chaparral Exhibits D078), Nov. 7, 1996.
- Distribution Agreement Between Hewlett-Packard and Crossroads (Dunning Ex 15 (HP 326-33)) (CD-ROM Chaparral Exhibits D079).
- HPFC-5000 Tachyon User's Manuel, First Edition (PTI 17249-839) (CD-ROM Chaparral Exhibits D084), May 1, 1996.
- X3T10 994D-(Draft) Information Technology: SCSI-3 Architecture Model, Rev. 1.8 (PTI 165977) (CD-ROM Chaparral Exhibits D087).
- X3T10 Project 1047D: Information Technology-SCSI-3 Controller Commands (SCC), Rev. 6c (PTI 166400-546) (CD-ROM Chaparral Exhibits D088), Sep. 3, 1996.
- X3T10 995D-(Draft) SCSI-3 Primary Commands, Rev. 11 (Wanamaker Ex 5 (PTI 166050-229)) (CD-ROM Chaparral Exhibits D089), Nov. 13, 1996.
- VBAR Volume Backup and Restore (CRDS 12200-202) (CD-ROM Chaparral Exhibits D099).
- Preliminary Product Literature for Infinity Commstor's Fibre Channel to SCSI Protocol Bridge (Smith Ex 11; Quisenberry Ex 31 (SPLO 428-30)) (CD-ROM Chaparral Exhibits D143), Aug. 19, 1996.
- Letter dated Jul. 12, 1996 from J. Boykin to B. Smith re: Purchase Order for Evaluation Units from Crossroads (Smith Ex 24) CRDS 8556-57) (CD-ROM Chaparral Exhibits D144), Jul. 12, 1996.
- CrossPoint 4100 Fibre Channel to SCSI Router Preliminary Datasheet (Hulsey Ex 9 (CRDS 16129-130)) (CD-ROM Chaparral Exhibits D145), Nov. 1, 1996.
- CrossPoint 4400 Fibre Channel to SCSI Router Preliminary Datasheet (Bardach Ex. 9, Quisenberry Ex 33 (CRDS 25606-607)) (CD-ROM Chaparral Exhibits D153), Nov. 1, 1996.
- Fax Dated Jul. 22, 1996 from L. Petti to B. Smith re: Purchase Order from Data General for FC2S Fibre to Channel SCSI Protocol Bridge Model 11 (Smith Ex 25; Quisenberry Ex 23; Bardach Ex 11 (CRDS 8552-55; 8558)) (CD-ROM Chaparral Exhibits D155).
- Email Dated Dec. 20, 1996 from J. Boykin to B. Smith re: Purchase Order for Betas in Feb. and Mar. (Hoese Ex 16, Quisenberry Ex 25; Bardach Ex 12 (CRDS 13644-650)) (CD-ROM Chaparral Exhibits D156).
- Infinity Commstor Fibre Channel Demo for Fall Comdex, 1996 (Hoese Ex 15, Bardach Ex 13 (CRDS 27415)) (CD-ROM Chaparral Exhibits D157).
- Fax Dated Dec. 19, 1996 from B. Bardach to T. Rarich re: Purchase Order Information (Bardach Ex. 14; Smith Ex 16 (CRDS 4460)) (CD-ROM Chaparral Exhibits D158).
- Miscellaneous Documents Regarding Comdex (Quisenberry Ex 2 (CRDS 27415-465)) (CD-ROM Chaparral Exhibits D165).
- CrossPoint 4100 Fibre Channel to SCSI Router Preliminary Datasheet (Quisenberry) Ex 3 (CRDS 4933-34) (CD-ROM Chaparral Exhibits D166) (CD-ROM Chaparral Exhibits D166).
- CrossPoint 4400 Fibre to Channel to SCSI Router Preliminary Datasheet; Crossroads Company and Product Overview (Quisenberry Ex 4 (CRDS 25606; 16136)) (CD-ROM Chaparral Exhibits D167).
- Crossroads Purchase Order Log (Quisenberry Ex 9 (CRDS 14061-062)) (CD-ROM Chaparral Exhibits D172).
- RAID Manager 5 with RDAC 5 for UNIX V.4 User's Guide (LSI-01854) (CD-ROM Chaparral Exhibits P062), Sep. 1, 1996.
- Letter dated May 12, 1997 from Alan G. Leal to Barbara Bardach enclosing the original OEM License and Purchase Agreement between Hewlett-Packard Company and Crossroads Systems, Inc. (CRDS 02057) (CD-ROM Chaparral Exhibits P130).
- CR4x00 Product Specification (CRDS 43929) (CD-ROM Chaparral Exhibits P267), Jun. 1, 1998.
- Symbios Logic-Hardware Functional Specification for the Symbios Logic Series 3 Fibre Channel Disk Array Controller Model 3701 (Engelbrecht Ex 3 (LSI-1659-1733)) (CD-ROM Pathlight Exhibits D074).
- Report of the Working Group on Storage I/O for Large Scale Computing; Department of Computer Science Duke University: CS-1996-21 (PTI 173330-347). (CD-ROM Pathlight Exhibits D098).
- Brian Allison's 1999 Third Quarter Sales Plan (PDX 38)CNS 022120-132)) (CD-ROM Pathlight Exhibits D201), Jun. 5, 2001.
- Brooklyn SCSI-SCSI Intelligent External RAID Bridge Definition Phase External Documentation (CD-ROM Pathlight Exhibits D129).
- "InfoServer 100 System Operations Guide", First Edition, Digital Equipment Corporation, 1990.
- S.P. Joshi, "Ethernet controller chip interfaces with variety of 16-bit processors," Electronic Design, Hayden Publishing Co., Inc., Rochelle Park, NJ, Oct. 14, 1982, pp 193-200.
- "DP5380 Asynchronous SCSI Interface", National Semiconductor Corporation, Arlington, TX, May 1989, pp. 1-32.
- Johnson, D.B., et al., "The Peregrine High Performance RPC System", Software-Practice & Experience, 23(2):201-221, Feb. 1993.
- "InfoServer 150-Installation and Owner's Guide", EK-INFV-OM-001, Digital Equipment Corporation, Maynard, Massachusetts 1991, Chapters 1 and 2.
- Pictures of internal components of the InfoServer 150, taken from <http://www.binarydinosaurs.couk/Museum/Digital/infoserver/infoserver.php> in Nov. 2004.

* cited by examiner

US 6,425,035 C1

1
EX PARTE
REEXAMINATION CERTIFICATE
ISSUED UNDER 35 U.S.C. 307

NO AMENDMENTS HAVE BEEN MADE TO
THE PATENT

2
AS A RESULT OF REEXAMINATION, IT HAS BEEN
DETERMINED THAT:

5 The patentability of claims **1-14** is confirmed.

* * * * *

THIS PAGE BLANK (USPTO)

IN THE UNITED STATES PATENT AND TRADEMARK OFFICE	
CERTIFICATE OF SERVICE UNDER 37 C.F.R. 1.248	Atty. Docket No. CROSS1123-17 CROSS1123-19
Applicant Geoffrey B. Hoese, et al.	
Reexamination Control No. 90/007,125 90/007,317	Date Filed 07/19/2004 11/23/2004
Title Storage Router and Method for Providing Virtual Local Storage	
Group Art Unit 2182	Examiner Chen, Alan

Applicant hereby serves the Comments on Statement of Reasons for Patentability and/or Confirmation in the above referenced case to:

Larry E. Severin
Wang, Hartmann & Gibbs, PC
1301 Dove Street, #1050
Newport Beach, CA 92660

William A. Blake
Jones, Tullar & Cooper, PC
P.O. Box 2226 Eads Station
Alexandria, VA 22202

As per 35 U.S.C. §1.248 service is made via first class mail, certified, R.R.R. on October 7, 2005.

Respectfully submitted,

Sprinkle IP Law Group

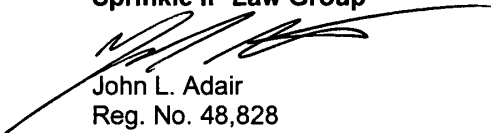

John L. Adair
Reg. No. 48,828

Dated: October 7, 2005

1301 W. 25th Street, Suite 408
Austin, Texas 78705
Tel. (512) 637-9220
Fax. (512) 371-9088

Enclosures

IN THE UNITED STATES PATENT AND TRADEMARK OFFICE	
Comments On Statement of Reasons for Patentability and/or Confirmation	Atty. Docket No. CROSS1123-17 CROSS1123-19
Applicants Goeffrey B. Hoese, et al.	
Reexamination Control No. 90/007,125 90/007,317	Date Filed 07/19/2004 11/23/2004
Title Storage Router and Method for Providing Virtual Local Storage	
Group Art Unit 2182	Examiner Chen, Alan

Commissioner for Patents
P.O. Box 1450
Alexandria, VA 22313-1450

Dear Sir:

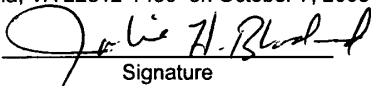
<u>Certificate of Mailing Under 37 C.F.R. §1.8</u>
I hereby certify that this correspondence is being deposited with the United States Postal Service as First Class Mail in an envelope addressed to Commissioner for Patents, P.O. Box 1450, Alexandria, VA 22312-1450 on October 7, 2005.
 Signature
Julie H. Blackard Printed Name

Applicants appreciate the Examiner's confirmation of Claims 1-14 of United States Patent No. 6,425,035. Applicants submit the record as a whole makes evident the reasons for allowance and that there are additional reasons for patentability not enumerated by the Examiner. While Applicants agree with the Examiner's reasons for patentability to the extent such reasons are consistent with the record as a whole (as Applicants understand them to be), Applicants do not acquiesce or agree to any characterization of the claims that place unwarranted limitations or interpretations upon the claims, especially to the extent such limitations or interpretations are inconsistent with the claim language, specification or prior prosecution history in this case.

Attorney Docket No.
CROSS1123-17
CROSS1123-19

Customer ID: 44654
90/007,125
90/007,317

2

These "Comments on Statement of Reasons for Patentability and/or Confirmation" was served via First Class Mail, Certified, R.R.R. on October 7, 2005 to Larry E. Severin of Wang, Hartmann & Gibbs, PC, 1301 Dove Street, #1050, Newport Beach, CA 92660 and to William A. Blake of Jones, Tullar & Cooper, PC, P.O. Box 2226 Eads Station, Alexandria, VA 22202

The Director of the U.S. Patent and Trademark Office is hereby authorized to charge any fees or credit any overpayments to Deposit Account No. 50-3183 of Sprinkle IP Law Group.

Respectfully submitted,

Sprinkle IP Law Group
Attorneys for Applicant

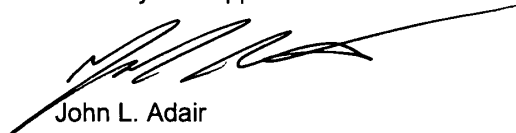

John L. Adair
Reg. No. 48,828

Date: October 7, 2005

1301 W. 25th Street, Suite 408
Austin, TX 78705
Tel. (512) 637-9223
Fax. (512) 371-9088



UNITED STATES PATENT AND TRADEMARK OFFICE

UNITED STATES DEPARTMENT OF COMMERCE
United States Patent and Trademark Office
Address: COMMISSIONER FOR PATENTS
P.O. Box 1450
Alexandria, Virginia 22313-1450
www.uspto.gov

APPLICATION NO.	FILING DATE	FIRST NAMED INVENTOR	ATTORNEY DOCKET NO.	CONFIRMATION NO.
90/007,125 44/007317	07/19/2004	6425035	I006-8910	2298
44654 7590 09/23/2005				
SPRINKLE IP LAW GROUP 1301 W. 25TH STREET SUITE 408 AUSTIN, TX 78705			EXAMINER CHEN, ALAN	
			ART UNIT	PAPER NUMBER
			2182	

DATE MAILED: 09/23/2005

Please find below and/or attached an Office communication concerning this application or proceeding.



UNITED STATES DEPARTMENT OF COMMERCE
Patent and Trademark Office

Address: ASSISTANT COMMISSIONER FOR PATENTS
Washington, D.C. 20231

APPLICATION NO/ CONTROL NO.	FILING DATE	FIRST NAMED INVENTOR / PATENT IN REEXAMINATION	ATTORNEY DOCKET NO.
90/007,317 <i>90/0071215</i>	11/23/2004	6425035	HOESE1/WAB

Larry E. Severin
Wang, Hartman & Gibbs, PC
1301 Dove Street
Suite 1050
Newport Beach, CA 92660

EXAMINER
CHEN, ALAN

ART UNIT PAPER

2182

DATE MAILED: *9-23-05*

Please find below and/or attached an Office communication concerning this application or proceeding.

Commissioner of Patents and Trademarks

CC: SPRINKLE IP LAW GROUP
1301 W. 25th Street
Suite 408
Austin, TX 78705

Notice of Intent to Issue Ex Parte Reexamination Certificate	Control No. 90/007,125 merged w/ 90/007,317	Patent Under Reexamination 6425035	
	Examiner Alan S. Chen	Art Unit 2182	

-- The MAILING DATE of this communication appears on the cover sheet with the correspondence address --

1. Prosecution on the merits is (or remains) closed in this *ex parte* reexamination proceeding. This proceeding is subject to reopening at the initiative of the Office or upon petition. Cf. 37 CFR 1.313(a). A Certificate will be issued in view of
 - (a) Patent owner's communication(s) filed: 22 July 2005.
 - (b) Patent owner's late response filed: _____.
 - (c) Patent owner's failure to file an appropriate response to the Office action mailed: _____.
 - (d) Patent owner's failure to timely file an Appeal Brief (37 CFR 41.31).
 - (e) Other: _____.

Status of *Ex Parte* Reexamination:

 - (f) Change in the Specification: Yes No
 - (g) Change in the Drawing(s): Yes No
 - (h) Status of the Claim(s):
 - (1) Patent claim(s) confirmed: 1-14.
 - (2) Patent claim(s) amended (including dependent on amended claim(s)): _____
 - (3) Patent claim(s) cancelled: _____.
 - (4) Newly presented claim(s) patentable: _____.
 - (5) Newly presented cancelled claims: _____.
2. Note the attached statement of reasons for patentability and/or confirmation. Any comments considered necessary by patent owner regarding reasons for patentability and/or confirmation must be submitted promptly to avoid processing delays. Such submission(s) should be labeled: "Comments On Statement of Reasons for Patentability and/or Confirmation."
3. Note attached NOTICE OF REFERENCES CITED (PTO-892).
4. Note attached LIST OF REFERENCES CITED (PTO-1449 or PTO/SB/08).
5. The drawing correction request filed on _____ is: approved disapproved.
6. Acknowledgment is made of the priority claim under 35 U.S.C. § 119(a)-(d) or (f).
 - a) All b) Some* c) None of the certified copies have
 - been received.
 - not been received.
 - been filed in Application No. _____.
 - been filed in reexamination Control No. _____.
 - been received by the International Bureau in PCT Application No. _____.

* Certified copies not received: _____.
7. Note attached Examiner's Amendment.
8. Note attached Interview Summary (PTO-474).
9. Other: _____.

cc: Requester (if third party requester)
U.S. Patent and Trademark Office
PTOL-469 (Rev.9-04)

Notice of Intent to Issue Ex Parte Reexamination Certificate

Part of Paper No 09022005

Copied from 90007125 on 10/07/2005

REEXAMINATION
REASONS FOR PATENTABILITY / CONFIRMATION

Reexamination Control No. 90/007,125 *merged w/* Attachment to Paper No. 09022005.
901007317

Art Unit 2182.

Claims 1-14 are allowed.

The prior art disclosed by the patent owner and cited by the Examiner fail to teach or suggest, alone or in combination, all the limitations of the independent claims (claims 1, 7 and 11), particularly the map/mapping feature which is a one-to-one correspondence, as given in a simple table, the map physically resident on a router, whereby the router forms the connection between two separate entities over different transport mediums, such that neither entity determines where data is to be sent, but rather, the router solely dictates where the data will be sent; also the "NLLBP" feature referring to a fundamental low level protocol defined by a specification/standard that is well known to one of ordinary skill in the art, where the NLLBP is used at the router for communications with both the first and second transport medium. The SCSI protocol/standard is considered a NLLBP. TCP/IP, e.g., used in Ethernet communications, however, is not considered to be a NLLBP.

PTOL-476 (Rev. 03-98)

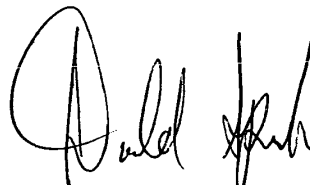

(Examiner's Signature)

DONALD SPARKS
SUPERVISORY PATENT EXAMINER

DOV POPOVICI
SUPERVISORY PATENT EXAMINER
TECHNOLOGY CENTER 2100

KIM HUYNH
PRIMARY EXAMINER

Copied from 90007125 on 10/07/2005

Reexamination 	Application/Control No. 90/007125 merged w/ 90/007317	Applicant(s)/Patent Under Reexamination 6425035
	Certificate Date	Certificate Number



Requester	Correspondence Address:	<input type="checkbox"/> Patent Owner	<input type="checkbox"/> Third Party

LITIGATION REVIEW <input checked="" type="checkbox"/>	<i>ASC</i> (examiner initials)	<i>9/19/05</i> (date)
Case Name		Director Initials
Crossroads Systems, (Texas), Inc v. Dot Hill Systems Western District of Texas (03-CV-754)		

COPENDING OFFICE PROCEEDINGS	
TYPE OF PROCEEDING	NUMBER
1. Reexamination merged	90/007317
2.	
3.	
4.	

Issue Classification 	Application/Control No.	Applicant(s)/Patent under Reexamination	
	90/007,125 merged w/ 90/007,317	6425035	
	Examiner	Art Unit	
	Alan S. Chen	2182	

ISSUE CLASSIFICATION										
ORIGINAL				CROSS REFERENCE(S)						
CLASS	SUBCLASS			CLASS	SUBCLASS (ONE SUBCLASS PER BLOCK)					
710	315			710	2	8	36	105	305	308
INTERNATIONAL CLASSIFICATION				711	112					
G	0	6	F	13/00						
				/						
				/						
				/						
				/						

 (Assistant Examiner) (Date) 9/16/05	 DOV POPOVICI SUPERVISORY PATENT EXAMINER (Supervisory Examiner) 2100 (Date) 9/21/05	Total Claims Allowed: 14 <table border="1" style="width: 100%;"> <tr> <td>O.G. Print Claim(s)</td> <td>O.G. Print Fig.</td> </tr> <tr> <td style="text-align: center;">1</td> <td style="text-align: center;">5</td> </tr> </table>	O.G. Print Claim(s)	O.G. Print Fig.	1	5
O.G. Print Claim(s)	O.G. Print Fig.					
1	5					
(Legal Instruments Examiner) (Date)						

<input checked="" type="checkbox"/> Claims renumbered in the same order as presented by applicant		<input type="checkbox"/> CPA		<input type="checkbox"/> T.D.		<input type="checkbox"/> R.1.47							
Final	Original	Final	Original	Final	Original	Final	Original						
1	1		31		61		91		121		151		181
2	2		32		62		92		122		152		182
3	3		33		63		93		123		153		183
4	4		34		64		94		124		154		184
5	5		35		65		95		125		155		185
6	6		36		66		96		126		156		186
7	7		37		67		97		127		157		187
8	8		38		68		98		128		158		188
9	9		39		69		99		129		159		189
10	10		40		70		100		130		160		190
11	11		41		71		101		131		161		191
12	12		42		72		102		132		162		192
13	13		43		73		103		133		163		193
14	14		44		74		104		134		164		194
	15		45		75		105		135		165		195
	16		46		76		106		136		166		196
	17		47		77		107		137		167		197
	18		48		78		108		138		168		198
	19		49		79		109		139		169		199
	20		50		80		110		140		170		200
	21		51		81		111		141		171		201
	22		52		82		112		142		172		202
	23		53		83		113		143		173		203
	24		54		84		114		144		174		204
	25		55		85		115		145		175		205
	26		56		86		116		146		176		206
	27		57		87		117		147		177		207
	28		58		88		118		148		178		208
	29		59		89		119		149		179		209
	30		60		90		120		150		180		210

Search Notes



Application No. 7.317. 90/007,125 <i>Merged with</i>	Applicant(s) 6425035
Examiner Fritz M Fleming	Art Unit 2182

SEARCHED			
Class	Subclass	Date	Examiner
710	1-5, 8-13, 36-38, 105, 100, 101, 126	1/21/05	FWF
711	100, 112, 113	1/21/05	FWF
714	42	1/21/05	FWF
710	305-316		
<i>updated</i>	<i>draw</i>	<i>5/20/05</i>	<i>FWF</i>
<i>updated</i>		<i>9/16/05</i>	<i>ASL</i>

INTERFERENCE SEARCHED			
Class	Subclass	Date	Examiner
<i>updated</i>	<i>see search history products</i>	<i>9/16/05</i>	<i>ASL</i>

SEARCH NOTES (INCLUDING SEARCH STRATEGY)		
	DATE	EXMR
EAST SEARCH NOTES	1/21/05	FWF
NPL SEARCH: SCSI, FC, Fibre Channel, storage, block level, native ATM	1/21/05	FWF
EAST SCSI ARRAY DMA FIFO	5/20/05	FWF
<i>updated</i> IEEE Xpress Byte Schedulers Fibre channel, native, SCSI	9/16/05	ASL

Index of Claims



Application No.

90/007,125 marked with F, S, T

Applicant(s)

6425035

Examiner

Fritz M Fleming

Art Unit

2182

√	Rejected
=	Allowed

-	(Through numeral) Cancelled
+	Restricted

N	Non-Elected
I	Interference

A	Appeal
O	Objected

Claim		Date	
Final	Original		
1	1		
2	2		
3	3		
4	4		
5	5		
6	6		
7	7		
8	8		
9	9		
10	10		
11	11		
12	12		
13	13		
14	14		
15			
16			
17			
18			
19			
20			
21			
22			
23			
24			
25			
26			
27			
28			
29			
30			
31			
32			
33			
34			
35			
36			
37			
38			
39			
40			
41			
42			
43			
44			
45			
46			
47			
48			
49			
50			

Claim		Date	
Final	Original		
51			
52			
53			
54			
55			
56			
57			
58			
59			
60			
61			
62			
63			
64			
65			
66			
67			
68			
69			
70			
71			
72			
73			
74			
75			
76			
77			
78			
79			
80			
81			
82			
83			
84			
85			
86			
87			
88			
89			
90			
91			
92			
93			
94			
95			
96			
97			
98			
99			
100			

Claim		Date	
Final	Original		
101			
102			
103			
104			
105			
106			
107			
108			
109			
110			
111			
112			
113			
114			
115			
116			
117			
118			
119			
120			
121			
122			
123			
124			
125			
126			
127			
128			
129			
130			
131			
132			
133			
134			
135			
136			
137			
138			
139			
140			
141			
142			
143			
144			
145			
146			
147			
148			
149			
150			

Ref #	Hits	Search Query	DBs	Default Operator	Plurals	Time Stamp
S1	3	@ad<"20010927" and (fibre adj channel near router) same SCSI	US-PGPUB; USPAT; EPO; JPO; DERWENT; IBM_TDB	OR	OFF	2005/08/22 08:44
S2	0	@ad<"19971231" and (fibre adj channel near router) same SCSI	US-PGPUB; USPAT; EPO; JPO; DERWENT; IBM_TDB	OR	OFF	2005/08/22 08:44
S3	111	@ad<"19971231" and fibre adj channel same SCSI	US-PGPUB; USPAT; EPO; JPO; DERWENT; IBM_TDB	OR	OFF	2005/08/22 08:45
S4	35	@ad<"19971231" and fibre adj channel near SCSI	US-PGPUB; USPAT; EPO; JPO; DERWENT; IBM_TDB	OR	OFF	2005/08/22 08:46
S5	1	S4 and router	US-PGPUB; USPAT; EPO; JPO; DERWENT; IBM_TDB	OR	OFF	2005/08/22 08:45
S6	7	@ad<"19971231" and fibre adj channel adj SCSI	US-PGPUB; USPAT; EPO; JPO; DERWENT; IBM_TDB	OR	OFF	2005/08/22 09:02
S7	0	@ad<"19971231" and "fibre channel protocol for SCSI"	US-PGPUB; USPAT; EPO; JPO; DERWENT; IBM_TDB	OR	OFF	2005/08/22 09:02
S8	14	@ad<"19971231" and FCP and SCSI and fibre adj channel	US-PGPUB; USPAT; EPO; JPO; DERWENT; IBM_TDB	OR	OFF	2005/08/22 09:07
S10	1	S8 and router	US-PGPUB; USPAT; EPO; JPO; DERWENT; IBM_TDB	OR	OFF	2005/08/22 09:03

S11	3	S8 and RAID	US-PGPUB; USPAT; EPO; JPO; DERWENT; IBM_TDB	OR	OFF	2005/08/22 09:18
S13	39	@ad<"20010927" and network adj attached adj storage and Fibre adj channel near scsi	US-PGPUB; USPAT; EPO; JPO; DERWENT; IBM_TDB	OR	OFF	2005/08/22 09:19
S14	19	S13 and router	US-PGPUB; USPAT; EPO; JPO; DERWENT; IBM_TDB	OR	OFF	2005/08/22 09:19
S15	0	@ad<"19971231" and network adj attached adj storage and Fibre adj channel near scsi	US-PGPUB; USPAT; EPO; JPO; DERWENT; IBM_TDB	OR	OFF	2005/09/03 14:23
S16	1	@ad<"19971231" and Fibre adj channel same scsi same router	US-PGPUB; USPAT; EPO; JPO; DERWENT; IBM_TDB	OR	OFF	2005/08/22 09:58
S18	8	@ad<"19971231" and ancor.asn.	US-PGPUB; USPAT; EPO; JPO; DERWENT; IBM_TDB	OR	OFF	2005/08/22 09:59
S19	0	@ad<"19971231" and ancor.asn. and SCSI	US-PGPUB; USPAT; EPO; JPO; DERWENT; IBM_TDB	OR	OFF	2005/08/22 09:59
S20	0	@ad<"19971231" and ancor.asn. and Fibre	US-PGPUB; USPAT; EPO; JPO; DERWENT; IBM_TDB	OR	OFF	2005/08/22 09:59
S21	0	@ad<"19971231" and emerson near steven.inv.	US-PGPUB; USPAT; EPO; JPO;	OR	OFF	2005/08/22 10:05
S22	4	@ad<"19971231" and SCSI near2 FCP	DERWENT; IBM_TDB US-PGPUB; USPAT; EPO; JPO; DERWENT; IBM_TDB	OR	OFF	2005/08/30 14:19

S23	139	@ad<"19971231". and fibre adj channel and SCSI	US-PGPUB; USPAT; EPO; JPO; DERWENT; IBM_TDB	OR	OFF	2005/08/30 14:48
S24	58	S23 and map\$5	US-PGPUB; USPAT; EPO; JPO; DERWENT; IBM_TDB	OR	OFF	2005/08/30 14:21
S25	14	S23 and LUN	US-PGPUB; USPAT; EPO; JPO; DERWENT; IBM_TDB	OR	OFF	2005/08/30 14:21
S26	11	S24 and LUN	US-PGPUB; USPAT; EPO; JPO; DERWENT; IBM_TDB	OR	OFF	2005/08/30 14:23
S27	0	S24 and virtual near local near storage	US-PGPUB; USPAT; EPO; JPO; DERWENT; IBM_TDB	OR	OFF	2005/08/30 14:22
S28	0	S23 and virtual near local near storage	US-PGPUB; USPAT; EPO; JPO; DERWENT; IBM_TDB	OR	OFF	2005/08/30 14:22
S29	8	S23 and router	US-PGPUB; USPAT; EPO; JPO; DERWENT; IBM_TDB	OR	OFF	2005/08/30 14:23
S30	0	@ad<"19971231" and virtual adj local adj storage and SCSI and remote	US-PGPUB; USPAT; EPO; JPO; DERWENT; IBM_TDB	OR	OFF	2005/08/30 14:49
S31	0	@ad<"19971231" and virtual adj local adj storage and SCSI	US-PGPUB; USPAT; EPO; JPO; DERWENT; IBM_TDB	OR	OFF	2005/08/30 14:49
S32	70	@ad<"19971231" and virtual near storage and SCSI	US-PGPUB; USPAT; EPO; JPO; DERWENT; IBM_TDB	OR	OFF	2005/08/30 14:49

S33	8	S32 and remote	US-PGPUB; USPAT; EPO; JPO; DERWENT; IBM_TDB	OR	OFF	2005/08/30 14:49
S34	5	@ad<"19971231" and router same fiber adj channel	US-PGPUB; USPAT; EPO; JPO; DERWENT; IBM_TDB	OR	OFF	2005/09/05 12:11
S35	1	"6425035".pn. and remote and map	US-PGPUB; USPAT; EPO; JPO; DERWENT; IBM_TDB	OR	OFF	2005/09/05 18:18
S36	1	"6425035".pn. and remote and map and maps and mapping	US-PGPUB; USPAT; EPO; JPO; DERWENT; IBM_TDB	OR	OFF	2005/09/05 18:55
S37	1	"6425035".pn. and remote and map and maps and mapping and native	US-PGPUB; USPAT; EPO; JPO; DERWENT; IBM_TDB	OR	OFF	2005/09/05 18:55

Access DB# 166173

SEARCH REQUEST FORM

Scientific and Technical Information Center

Requester's Full Name Pinchus Laufer Examiner #: 73139 Date: 09/19/05
Art Unit: NONE Phone Number 2-3599 Serial Number None
Mail Box Location: Results Format Preferred (circle): PAPER DISK E-MAIL

If more than one search is submitted, please prioritize searches in order of need.

Please provide a detailed statement of the search topic, and describe as specifically as possible the subject matter to be searched. Include the elected species or structures, keywords, synonyms, acronyms, and registry numbers, and combine with the concept or utility of the invention. Define any terms that may have a special meaning. Give examples or relevant citations, authors, etc, if known. Please attach a copy of the cover sheet, pertinent claims, and abstract.

Title of Invention: _____

Inventors (please provide full names): _____

Earliest Priority Filing Date: _____

**For Sequence Searches Only* Please include all pertinent information (parent, child, divisional, or issued patent numbers) along with the appropriate serial number.*

6425035

STAFF USE ONLY

Searcher: Shirelle Green
Searcher Phone #: 272-3487
Searcher Location: 4B28
Date Searcher Picked Up: 9/19
Date Completed: 9/19
Searcher Prep & Review Time: _____
Clerical Prep Time: _____
Online Time: 15

Type of Search

Sequence (#) _____
AA Sequence (#) _____
Structure (#) _____
Bibliographic _____
Litigation _____
Fulltext _____
Patent Family _____
Other _____

Vendors and cost where applicable

STN _____
Dialog _____
Questel/Orbit 11.80 _____
WEST _____
Lexis/Nexis _____
Sequence Systems _____
WWW/Internet _____
Other (specify) Courtlink 28.00

RECEIVED
SEP 19 2005

BY:.....

1 of 1 DOCUMENT

UNITED STATES PATENT AND TRADEMARK OFFICE GRANTED PATENT

6425035

[Link to Claims Section](#)

July 23, 2002

Storage router and method for providing virtual local storage

REEXAM-LITIGATE: July 19, 2004 - Reexamination requested by Natu J. Patel, Wang & Patel, Reexamination No. 90/007,125 (O.G. August 31, 2004) Ex. Gp: 2111

November 23, 2004 - Reexamination requested by William Blake, Jones Tullar & Cooper, Reexamination No. 90/007,317 (O.G. January 11, 2005) Ex. Gp: 2182

NOTICE OF LITIGATION

Crossroads Systems (Texas), Inc., a Texas Corporation v. Dot Hill Systems Corporation, a Delaware corporation, Filed October 17, 2003, D.C. W.D. Texas, Doc. No. A-03-CA-754-55

INVENTOR: Hoese, Geoffrey B. - Austin, Texas; Russell, Jeffrey T. - Cibolo, Texas

APPL-NO: 965335 (09)

FILED-DATE: September 27, 2001

GRANTED-DATE: July 23, 2002

ASSIGNEE-AT-ISSUE: Crossroads Systems, Inc., Austin, Texas, 02

ENGLISH-ABST:

A storage router (56) and storage network (50) provide virtual local storage on remote SCSI storage devices (60, 62, 64) to Fiber Channel devices. A plurality of Fiber Channel devices, such as workstations (58), are connected to a Fiber Channel transport medium (52), and a plurality of SCSI storage devices (60, 62, 64) are connected to a SCSI bus transport medium (54). The storage router (56) interfaces between the Fibre Channel transport medium (52) and the SCSI bus transport medium (54). The storage router (56) maps between the workstations (58) and the SCSI storage devices (60, 62, 64) and implements access controls for storage space on the SCSI storage devices (60, 62, 64). The storage router (56) then allows access from the workstations (58) to the SCSI storage devices (60, 62, 64) using native low level, block protocol in accordance with the mapping and the access controls.

PARENT-PAT-INFO:

RELATED APPLICATIONS

This application claims the benefit of the filing date of U.S. patent application Ser. No. 09/354,682 by inventors Geoffrey B. Hoese and Jeffrey T. Russell, entitled "Storage Router and Method for Providing Virtual Local Storage" filed on Jul. 15, 1999, which is a continuation of U.S. patent application Ser. No. 091001,799, filed on Dec. 31, 1997, now U.S. Pat. No. 5,941,972, and hereby incorporates these applications by reference in their entireties as if they had been fully set forth herein.

LEXIS-NEXIS
Library: PATENTS
File: ALL

No Documents Found!

No documents were found for your search terms
"6425035 or 6,425,035"

Click "Save this search as an Alert" to schedule your search to run in the future.

- OR -

Click "Edit Search" to return to the search form and modify your search.

Suggestions:

- Check for spelling errors.
- Remove some search terms.
- Use more common search terms, such as those listed in "Suggested Words and Concepts"
- Use a less restrictive date range.

Save this Search as an Alert

[About LexisNexis](#) | [Terms and Conditions](#)

Copyright © 2005 LexisNexis, a division of Reed Elsevier Inc. All rights reserved.

LEXIS-NEXIS
Library: PATENTS
File: CASES

No Documents Found!

No documents were found for your search terms
"6425035 or 6,425,035"

Click "Save this search as an Alert" to schedule your search to run in the future.

- OR -

Click "Edit Search" to return to the search form and modify your search.

Suggestions:

- Check for spelling errors.
- Remove some search terms.
- Use more common search terms, such as those listed in "Suggested Words and Concepts"
- Use a less restrictive date range.

Save this Search as an Alert

[About LexisNexis](#) | [Terms and Conditions](#)

Copyright © 2005 LexisNexis, a division of Reed Elsevier Inc. All rights reserved.

LEXIS-NEXIS
Library: PATENTS
File: JNLS

1 of 2 DOCUMENTS

Copyright 2003 Comtex News Network, Inc.
All Rights Reserved
Copyright 2003 Knobias.com, LLC, All rights reserved.
Knobias.com

This content is provided to LexisNexis by Comtex News Network, Inc.

October 22, 2003 Wednesday

LENGTH: 74 words

HEADLINE: CRDS Files Patent Infringement Suit Against HILL

DATELINE: Ridgeland, MS

BODY:

...not been served with the Complaint. The suit alleges patent infringement by Dot Hill of United States Patent Nos. 5,941,972 and 6,425,035, relating to storage routers and methods for providing virtual local storage.

LEXIS-NEXIS
Library: PATENTS
File: CURNEWS

2 of 2 DOCUMENTS

Copyright 2003 PR Newswire Association, Inc.
PR Newswire

October 22, 2003 Wednesday

SECTION: FINANCIAL NEWS

LENGTH: 446 words

HEADLINE: Dot Hill Systems Announces Complaint Filed By Crossroads Systems

DATELINE: CARLSBAD, Calif. Oct. 22

BODY:

...not been served with the Complaint. The suit alleges patent infringement by Dot Hill of United States Patent Nos. 5,941,972 and 6,425,035, relating to storage routers and methods for providing virtual local storage.

?us6425035/pn

** SS 1: Results 1

Search statement 2

?prt full nonstop legalall

1/1 PLUSPAT - (C) QUESTEL-ORBIT- image
PN - US2002010812 A1 20020124 [US20020010812]
PN2 - US6425035 B2 20020723 [US6425035]
TI - (A1) Storage router and method for providing virtual local storage
PA - (B2) CROSSROADS SYS INC (US)
PA0 - Crossroads Systems, Inc., Austin TX [US]
PA2 - (B2) CROSSROADS SYS INC (US)
IN - (A1) HOESE GEOFFREY B (US); RUSSELL JEFFRY T (US)
AP - US96533501 20010927 [2001US-0965335]
FD - Continuation of: US5941972
PR - US96533501 20010927 [2001US-0965335]
- US35468299 19990715 [1999US-0354682]
- US179997 19971231 [1997US-0001799]
IC - (A1) G06F-003/00
EC - G06F-013/40D2
PCL - ORIGINAL (O) : 710105000; CROSS-REFERENCE (X) : 710008000 710036000
710310000
DT - Corresponding document
CT - US5748924; US5768623; US5809328; US5812754; US5835496; US5848251;
US5935260; US5941972; US5959994; US6041381; US6055603; US6065087;
US6075863; US6098149; US6118766; US6148004; US6185203; US6209023;
US6230218; US6341315; US6343324
STG - (A1) Utility Patent Application published on or after January 2, 2001
STG2- (B2) U.S. Patent (with pre-grant pub.) after Jan. 2, 2001
AB - A storage router (56) and storage network (50) provide virtual local
storage on remote SCSI storage devices (60, 62, 64) to Fiber Channel
devices. A plurality of Fiber Channel devices, such as workstations
(58), are connected to a Fiber Channel transport medium (52), and a
plurality of SCSI storage devices (60, 62, 64) are connected to a SCSI
bus transport medium (54). The storage router (56) interfaces between
the Fibre Channel transport medium (52) and the SCSI bus transport
medium (54). The storage router (56) maps between the workstations
(58) and the SCSI storage devices (60, 62, 64) and implements access
controls for storage space on the SCSI storage devices (60, 62, 64).
The storage router (56) then allows access from the workstations (58)
to the SCSI storage devices (60, 62, 64) using native low level, block
protocol in accordance with the mapping and the access controls.
UP - 2002-05

1/1 LGST - (C) EPO
PN - US2002010812 A1 20020124 [US20020010812]
- US6425035 B2 20020723 [US6425035]
AP - US96533501 20010927 [2001US-0965335]
ACT - 20030826 US/CC-A
CERTIFICATE OF CORRECTION
- 20040831 US/RR-A [+]
REQUEST FOR REEXAMINATION FILED
EFFECTIVE DATE: 20040719
- 20050111 US/RR-A [+]
REQUEST FOR REEXAMINATION FILED
EFFECTIVE DATE: 20041123
UP - 2005-05

.1/1 CRXX - (C) CLAIMS/RRX

PN - 6,425,035 A 20020723 [US6425035]
PA - Crossroads Systems Inc
ACT - 20040719 REEXAMINATION REQUESTED
ISSUE DATE OF O.G.: 20040831
REEXAMINATION REQUEST NUMBER: 90/007125
Natu J. Patel, Wang & Patel, Newport Beach, CA

- 20041123 REEXAMINATION REQUESTED
ISSUE DATE OF O.G.: 20050111
REEXAMINATION REQUEST NUMBER: 90/007317
William Blake, Jones Tullar & Cooper, Alexandria, VA

US District Court Civil Docket

**U.S. District - Texas Western
(Austin)**

1:03cv754

Crossroads Systems (v. Dot Hill Systems Cor

This case was retrieved from the court on Monday, September 19, 2005

Date Filed: 10/17/2003 **Class Code: PATTRD**
Assigned To: Honorable Sam Sparks **Closed: no**
Referred To: **Statute: 28:1338**
Nature of suit: Patent (830) **Jury Demand: Both**
Cause: Patent Infringement **Demand Amount: \$0**
Lead Docket: None **NOS Description: Patent**
Other Docket: None
Jurisdiction: Federal Question

Litigants

Attorneys

Crossroads Systems (Texas), Inc, A Texas Corporation
Plaintiff

Alan D Albright
[COR LD NTC]
[Term: 03/08/2005]
Fish & Richardson
One Congress Plaza
111 Congress Ave
4TH Floor
Austin , TX 78701
USA
(512) 391-4930
512/ 391-6837

Raymond W Mort
[COR LD NTC]
Dla Piper Rudnick Gray Cary US, LLP
1221 S Mopac Expressway
Suite 400
Austin , TX 78746-6875
USA
(512) 457-7000
512/ 457-7001

J Eric Elliff
[COR LD NTC]
Morrison & Foerster LLP
5200 Republic Plaza
370 Seventeenth Street
Denver , CO 80202-5638
USA
(303)592-1500
(303)592-1510

Tracy L McCreight
[COR LD NTC]
[Term: 03/08/2005]
Gray Cary Ware & Freidenrich
1221 S Mopac Expwy
Suite 400
Austin , TX 78746-6875
USA
(512) 457-7128

512/ 457-7001

Joseph P Reid
[COR LD NTC]
[Term: 03/08/2005]
Gray Cary Ware & Freidenrich LLP
401 B Street, Suite 2000
San Diego , CA 92101-4240
USA
(619) 699-2800
(619) 699-2701

John Allcock
[COR LD NTC]
Gray Cary Ware & Freidenrich, LLP
401 B Street
Suite 2000
San Diego , CA 92101-4240
USA
(619) 699-2828
(619) 699-2701

John E Giust
[COR LD NTC]
[Term: 03/08/2005]
Gray Cary Ware & Freidenrich, LLP
401 B Street
Suite 2000
San Diego , CA 92101-4240
USA
(619) 699-2828
(619) 699-2701

Matthew C Bernstein
[COR LD NTC]
[Term: 03/08/2005]
Gray Cary Ware & Freidenrich, LLP
401 B Street
Suite 2000
San Diego , CA 92101-4240
USA
(619) 699-2828
619/ 699-2701

John Michael Guaragna
[COR LD NTC]
Dia Piper Rudnick Gray Cary US LLP
1221 South Mopac Expressway
Suite 400
Austin , TX 78746
USA
(512) 457-7125
512/ 457-7001

Barry K Shelton
[COR LD NTC]
[Term: 03/08/2005]
Fish & Richardson, PC
111 Congress Avenue
4TH Floor
Austin , TX 78701
USA
(512) 391-4929
512/ 391-6837

Darius C Gambino
[COR LD NTC]
Dia Piper Rudnick Gray Cary US LLP
1650 Market Street
Suite 4900
Philadelphia , PA 19103

Dot Hill Systems Corporation, A Delaware Corporation
Defendant

USA
215-656-3309
215/ 656-3301

Patton G Lochridge
[COR LD NTC]
McGinnis, Lochridge & Kilgore
919 Congress Avenue
1300 Capitol Center
Austin , TX 78701
USA
(512) 495-6000
512/ 495-6093

Kurt E Richter
[COR LD NTC]
Morgan & Finnegan
3 World Financial Center
New York , NY 10281-2101
USA
(212) 415-8700

John F Sweeney
[COR LD NTC]
Morgan & Finnegan
3 World Financial Center
New York , NY 10281-2101
USA
(212) 415-8700
212/ 751-6849

William S Feiler
[COR LD NTC]
Morgan & Finnegan
3 World Financial Center
New York , NY 10281-2101
USA
(212) 415-8700
212/ 415-8701

Travis C Barton
[COR LD NTC]
McGinnis, Lochridge & Kilgore
919 Congress Avenue
Suite 1300
Austin , TX 78701
USA
(512) 495-6041
512/ 495-6093

Daniel S Mount
[COR LD NTC]
[Term: 04/05/2004]
Mount & Stoelker
333 W San Carlos Street
Suite 1650
San Jose , CA 95110
USA
(408)279-7000
(408)998-1473

Lara J Hodgson
[COR LD NTC]
[Term: 04/05/2004]
Mount & Stoelker
333 W San Carlos Street
Suite 1650
San Jose , CA 95110
USA
(408)279-7000

408/ 998-1473

Alfredo A Bismonte
[COR LD NTC]
[Term: 04/05/2004]
Mount & Stoelker
333 W San Carlos Street
Suite 1650
San Jose , CA 95110
USA
(408)279-7000
(408)998-1473

Michael E Lovins
[COR LD NTC]
McGinnis, Lochridge & Kilgore
1300 Capitol Center
919 Congress Avenue
Austin , TX 78701
USA
(512) 495-6000
512/ 505-6364

Leslie M Hoekstra
[COR LD NTC]
[Term: 04/05/2004]
Mount & Stoelker
333 W San Carlos Street
Suite 1650
San Jose , CA 95110
USA
(408) 279-7000
(408) 998-1473

Valerie W Greenberg
[COR LD NTC]
Greenberg Law Firm
121 Brite Avenue
Scosdale , NY 10583
USA
(914) 722-9111

Natu J Patel
[COR LD NTC]
[Term: 10/05/2004]
Wang & Patel, PC
1301 Dove Street
Suite 1050
Newport Beach , CA 92660
USA
(949) 833-8483
949/ 833-2281

Larry E Severin
[COR LD NTC]
Wang & Patel, PC
1301 Dove Street, #1050
Newport Beach , CA 92660
USA
(949) 833-8483
(949) 833-2281

Franklin E Gibbs
[COR LD NTC]
Wang, Hartmann & Gibbs, PC
1301 Dove Street
Suite 1050
Newport Beach , CA 92660
USA
(949) 833-8483
(949) 833-2281

Jason Brian Witten
[COR LD NTC]
Wang, Hartmann & Gibbs, PC
1301 Dove Street
Suite 1050
Newport Beach , CA 92660
USA
(949) 833-8483
949/ 833-2281

Richard Franklin Cauley
[COR LD NTC]
Wang, Hartman & Gibbs PC
1301 Dove Street
Suite 1050
Newport Beach , CA. 92660
USA
949/ 833-8483
949/ 833-2281

Peter O Huang
[COR LD NTC]
Wang Hartmann & Gibbs PC
1301 Dove Street
Suite 1050
Newport Beach , CA 92660
USA
949-833-8483
949-833-2281

Dot Hill Systems Corporation, A Delaware Corporation
Counter-
Plaintiff

Patton G Lochridge
[COR LD NTC]
McGinnis, Lochridge & Kilgore
919 Congress Avenue
1300 Capitol Center
Austin , TX 78701
USA
(512) 495-6000
512/ 495-6093

Kurt E Richter
[COR LD NTC]
Morgan & Finnegan
3 World Financial Center
New York , NY 10281-2101
USA
(212) 415-8700

Travis C Barton
[COR LD NTC]
McGinnis, Lochridge & Kilgore
919 Congress Avenue
Suite 1300
Austin , TX 78701
USA
(512) 495-6041
512/ 495-6093

Daniel S Mount
[COR LD NTC]
[Term: 04/05/2004]
Mount & Stoelker
333 W San Carlos Street
Suite 1650
San Jose , CA 95110
USA
(408)279-7000
(408)998-1473

Lara J Hodgson
[COR LD NTC]
[Term: 04/05/2004]
Mount & Stoelker
333 W San Carlos Street
Suite 1650
San Jose , CA 95110
USA
(408)279-7000
408/ 998-1473

Alfredo A Bismonte
[COR LD NTC]
[Term: 04/05/2004]
Mount & Stoelker
333 W San Carlos Street
Suite 1650
San Jose , CA 95110
USA
(408)279-7000
(408)998-1473

Michael E Lovins
[COR LD NTC]
McGinnis, Lochridge & Kilgore
1300 Capitol Center
919 Congress Avenue
Austin , TX 78701
USA
(512) 495-6000
512/ 505-6364

Leslie M Hoekstra
[COR LD NTC]
[Term: 04/05/2004]
Mount & Stoelker
333 W San Carlos Street
Suite 1650
San Jose , CA 95110
USA
(408) 279-7000
(408) 998-1473

Valerie W Greenberg
[COR LD NTC]
Greenberg Law Firm
121 Brite Avenue
Scosdale , NY 10583
USA
(914) 722-9111

Natu J Patel
[COR LD NTC]
[Term: 10/05/2004]
Wang & Patel, PC
1301 Dove Street
Suite 1050
Newport Beach , CA 92660
USA
(949) 833-8483
949/ 833-2281

Larry E Severin
(949) 833-2281
Wang & Patel, PC
1301 Dove Street, #1050
Newport Beach , CA 92660
USA
(949) 833-8483

Franklin E Gibbs

(949) 833-2281
Wang, Hartmann & Gibbs, PC
1301 Dove Street
Suite 1050
Newport Beach , CA 92660
USA
(949) 833-8483

Jason Brian Witten
[COR LD NTC]
Wang, Hartmann & Gibbs, PC
1301 Dove Street
Suite 1050
Newport Beach , CA 92660
USA
(949) 833-8483
949/ 833-2281

Crossroads Systems (Texas), Inc, A Texas Corporation
Counter-Defendant

Alan D Albright
[COR LD NTC]
[Term: 03/08/2005]
Fish & Richardson
One Congress Plaza
111 Congress Ave
4TH Floor
Austin , TX 78701
USA
(512) 391-4930
512/ 391-6837

Raymond W Mort
512/457-7001
Dla Piper Rudnick Gray Cary US,
LLP
1221 S Mopac Expressway
Suite 400
Austin , TX 78746-6875
USA
(512) 457-7000

Tracy L McCreight
[COR LD NTC]
[Term: 03/08/2005]
Gray Cary Ware & Freidenrich
1221 S Mopac Expwy
Suite 400
Austin , TX 78746-6875
USA
(512) 457-7128
512/ 457-7001

Joseph P Reid
[Term: 03/08/2005]
(619) 699-2701
Gray Cary Ware & Freidenrich
LLP
401 B Street, Suite 2000
San Diego , CA 92101-4240
USA
(619) 699-2800

John Allcock
[COR LD NTC]
Gray Cary Ware & Freidenrich, LLP
401 B Street
Suite 2000
San Diego , CA 92101-4240
USA
(619) 699-2828
(619) 699-2701

John E Giust
[COR LD NTC]
[Term: 03/08/2005]
Gray Cary Ware & Freidenrich, LLP
401 B Street
Suite 2000
San Diego , CA 92101-4240
USA
(619) 699-2828
(619) 699-2701

Matthew C Bernstein
[COR LD NTC]
[Term: 03/08/2005]
Gray Cary Ware & Freidenrich, LLP
401 B Street
Suite 2000
San Diego , CA 92101-4240
USA
(619) 699-2828
619/ 699-2701

John Michael Guaragna
512/457-7001
Dia Piper Rudnick Gray Cary US
LLP
1221 South Mopac Expressway
Suite 400
Austin , TX 78746
USA
(512) 457-7125

Dot Hill Systems Corporation, A Delaware Corporation
Third-Party Plaintiff

Patton G Lochridge
[COR LD NTC]
McGinnis, Lochridge & Kilgore
919 Congress Avenue
1300 Capitol Center
Austin , TX 78701
USA
(512) 495-6000
512/ 495-6093

Kurt E Richter
[COR LD NTC]
Morgan & Finnegan
3 World Financial Center
New York , NY 10281-2101
USA
(212) 415-8700

John F Sweeney
[COR LD NTC]
Morgan & Finnegan
3 World Financial Center
New York , NY 10281-2101
USA
(212) 415-8700
212/ 751-6849

William S Feller
[COR LD NTC]
Morgan & Finnegan
3 World Financial Center
New York , NY 10281-2101
USA
(212) 415-8700
212/ 415-8701

Travis C Barton

[COR LD NTC]
McGinnis, Lochridge & Kilgore
919 Congress Avenue
Suite 1300
Austin , TX 78701
USA
(512) 495-6041
512/ 495-6093

Daniel S Mount
[COR LD NTC]
[Term: 04/05/2004]
Mount & Stoelker
333 W San Carlos Street
Suite 1650
San Jose , CA 95110
USA
(408)279-7000
(408)998-1473

Lara J Hodgson
[COR LD NTC]
[Term: 04/05/2004]
Mount & Stoelker
333 W San Carlos Street
Suite 1650
San Jose , CA 95110
USA
(408)279-7000
408/ 998-1473

Alfredo A Bismonte
[COR LD NTC]
[Term: 04/05/2004]
Mount & Stoelker
333 W San Carlos Street
Suite 1650
San Jose , CA 95110
USA
(408)279-7000
(408)998-1473

Michael E Lovins
[COR LD NTC]
McGinnis, Lochridge & Kilgore
1300 Capitol Center
919 Congress Avenue
Austin , TX 78701
USA
(512) 495-6000
512/ 505-6364

Leslie M Hoekstra
[COR LD NTC]
[Term: 04/05/2004]
Mount & Stoelker
333 W San Carlos Street
Suite 1650
San Jose , CA 95110
USA
(408) 279-7000
(408) 998-1473

Valerie W Greenberg
[COR LD NTC]
Greenberg Law Firm
121 Brite Avenue
Scosdale , NY 10583
USA
(914) 722-9111

Natu J Patel
[COR LD NTC]
[Term: 10/05/2004]
Wang & Patel, PC
1301 Dove Street
Suite 1050
Newport Beach , CA 92660
USA
(949) 833-8483
949/ 833-2281

Larry E Severin
[COR LD NTC]
Wang & Patel, PC
1301 Dove Street, #1050
Newport Beach , CA 92660
USA
(949) 833-8483
(949) 833-2281

Franklin E Gibbs
[COR LD NTC]
Wang, Hartmann & Gibbs, PC
1301 Dove Street
Suite 1050
Newport Beach , CA 92660
USA
(949) 833-8483
(949) 833-2281

Jason Brian Witten
[COR LD NTC]
Wang, Hartmann & Gibbs, PC
1301 Dove Street
Suite 1050
Newport Beach , CA 92660
USA
(949) 833-8483
949/ 833-2281

Falconstor Software, Inc
Third-Party Defendant
[Term: 09/17/2004]

George Barton Butts
[COR LD NTC]
[Term: 09/17/2004]
Dia Piper Rudnick Gray Cary US LLP
1221 S Mopac Expressway
Suite 400
Austin , TX 78746
USA
(512) 457-7068
512/ 457-7001

Mark J Schildkraut
[COR LD NTC]
[Term: 09/17/2004]
Kaye Scholer LLP
425 Park Ave
New York , NY 10022
USA
(212) 836-8000

Aaron Stiefel
[COR LD NTC]
[Term: 09/17/2004]
Kaye Scholer LLP
425 Park Ave
New York , NY 10022
USA
(212) 836-8000
212/ 836-8689

Falconstor Software, Inc
Cross-Claimant
[Term: 08/27/2004]

Stephen J Elliott
[COR LD NTC]
[Term: 09/17/2004]
Kaye Scholer LLP
425 Park Ave
New York , NY 10022
USA
(212) 836-8000

George Barton Butts
[COR LD NTC]
[Term: 08/27/2004]
Dla Piper Rudnick Gray Cary US LLP
1221 S Mopac Expressway
Suite 400
Austin , TX 78746
USA
(512) 457-7068
512/ 457-7001

Mark J Schildkraut
[COR LD NTC]
[Term: 08/27/2004]
Kaye Scholer LLP
425 Park Ave
New York , NY 10022
USA
(212) 836-8000

Aaron Stiefel
[COR LD NTC]
[Term: 08/27/2004]
Kaye Scholer LLP
425 Park Ave
New York , NY 10022
USA
(212) 836-8000
212/ 836-8689

Stephen J Elliott
[COR LD NTC]
[Term: 08/27/2004]
Kaye Scholer LLP
425 Park Ave
New York , NY 10022
USA
(212) 836-8000

Crossroads Systems (Texas), Inc, A Texas Corporation
Cross-Defendant

Alan D Albright
[COR LD NTC]
[Term: 03/08/2005]
Fish & Richardson
One Congress Plaza
111 Congress Ave
4TH Floor
Austin , TX 78701
USA
(512) 391-4930
512/ 391-6837

Raymond W Mort
512/457-7001
Dla Piper Rudnick Gray Cary US,
LLP
1221 S Mopac Expressway
Suite 400
Austin , TX 78746-6875
USA
(512) 457-7000

Tracy L McCreight
[COR LD NTC]
[Term: 03/08/2005]
Gray Cary Ware & Freidenrich
1221 S Mopac Expwy
Suite 400
Austin , TX 78746-6875
USA
(512) 457-7128
512/ 457-7001

Joseph P Reid
[Term: 03/08/2005]
(619) 699-2701
Gray Cary Ware & Freidenrich
LLP
401 B Street, Suite 2000
San Diego , CA 92101-4240
USA
(619) 699-2800

John Allcock
[COR LD NTC]
Gray Cary Ware & Freidenrich, LLP
401 B Street
Suite 2000
San Diego , CA 92101-4240
USA
(619) 699-2828
(619) 699-2701

John E Giust
[COR LD NTC]
[Term: 03/08/2005]
Gray Cary Ware & Freidenrich, LLP
401 B Street
Suite 2000
San Diego , CA 92101-4240
USA
(619) 699-2828
(619) 699-2701

Matthew C Bernstein
[COR LD NTC]
[Term: 03/08/2005]
Gray Cary Ware & Freidenrich, LLP
401 B Street
Suite 2000
San Diego , CA 92101-4240
USA
(619) 699-2828
619/ 699-2701

John Michael Guaragna
512/457-7001
Dla Piper Rudnick Gray Cary US
LLP
1221 South Mopac Expressway
Suite 400
Austin , TX 78746
USA
(512) 457-7125

Crossroads Systems (Texas), Inc, A Texas Corporation
Counter-
Plaintiff

Alan D Albright
[COR LD NTC]
[Term: 03/08/2005]
Fish & Richardson
One Congress Plaza
111 Congress Ave
4TH Floor

Austin , TX 78701
USA
(512) 391-4930
512/ 391-6837

Raymond W Mort
512/457-7001
Dla Piper Rudnick Gray Cary US,
LLP
1221 S Mopac Expressway
Suite 400
Austin , TX 78746-6875
USA
(512) 457-7000

Tracy L McCreight
[COR LD NTC]
[Term: 03/08/2005]
Gray Cary Ware & Freidenrich
1221 S Mopac Expwy
Suite 400
Austin , TX 78746-6875
USA
(512) 457-7128
512/ 457-7001

Joseph P Reid
[Term: 03/08/2005]
(619) 699-2701
Gray Cary Ware & Freidenrich
LLP
401 B Street, Suite 2000
San Diego , CA 92101-4240
USA
(619) 699-2800

John Allcock
[COR LD NTC]
Gray Cary Ware & Freidenrich, LLP
401 B Street
Suite 2000
San Diego , CA 92101-4240
USA
(619) 699-2828
(619) 699-2701

John E Giust
[COR LD NTC]
[Term: 03/08/2005]
Gray Cary Ware & Freidenrich, LLP
401 B Street
Suite 2000
San Diego , CA 92101-4240
USA
(619) 699-2828
(619) 699-2701

Matthew C Bernstein
[COR LD NTC]
[Term: 03/08/2005]
Gray Cary Ware & Freidenrich, LLP
401 B Street
Suite 2000
San Diego , CA 92101-4240
USA
(619) 699-2828
619/ 699-2701

John Michael Guaragna
512/457-7001
Dla Piper Rudnick Gray Cary US

Falconstor Software, Inc
Counter-Defendant
[Term: 08/27/2004]

LLP
1221 South Mopac Expressway
Suite 400
Austin , TX 78746
USA
(512) 457-7125

George Barton Butts
[COR LD NTC]
[Term: 08/27/2004]
Dla Piper Rudnick Gray Cary US LLP
1221 S Mopac Expressway
Suite 400
Austin , TX 78746
USA
(512) 457-7068
512/ 457-7001

Mark J Schildkraut
[COR LD NTC]
[Term: 08/27/2004]
Kaye Scholer LLP
425 Park Ave
New York , NY 10022
USA
(212) 836-8000

Aaron Stiefel
[COR LD NTC]
[Term: 08/27/2004]
Kaye Scholer LLP
425 Park Ave
New York , NY 10022
USA
(212) 836-8000
212/ 836-8689

Stephen J Elliott
[COR LD NTC]
[Term: 08/27/2004]
Kaye Scholer LLP
425 Park Ave
New York , NY 10022
USA
(212) 836-8000

Falconstor Software, Inc Counter-
Plaintiff
[Term: 08/27/2004]

George Barton Butts
[COR LD NTC]
[Term: 08/27/2004]
Dla Piper Rudnick Gray Cary US LLP
1221 S Mopac Expressway
Suite 400
Austin , TX 78746
USA
(512) 457-7068
512/ 457-7001

Mark J Schildkraut
[COR LD NTC]
[Term: 08/27/2004]
Kaye Scholer LLP
425 Park Ave
New York , NY 10022
USA
(212) 836-8000

Aaron Stiefel
[COR LD NTC]
[Term: 08/27/2004]
Kaye Scholer LLP

Crossroads Systems (Texas), Inc, A Texas Corporation
Counter-Defendant

425 Park Ave
New York , NY 10022
USA
(212) 836-8000
212/ 836-8689

Stephen J Elliott
[COR LD NTC]
[Term: 08/27/2004]
Kaye Scholer LLP
425 Park Ave
New York , NY 10022
USA
(212) 836-8000

Alan D Albright
[COR LD NTC]
[Term: 03/08/2005]
Fish & Richardson
One Congress Plaza
111 Congress Ave
4TH Floor
Austin , TX 78701
USA
(512) 391-4930
512/ 391-6837

Raymond W Mort
512/457-7001
Dla Piper Rudnick Gray Cary US,
LLP
1221 S Mopac Expressway
Suite 400
Austin , TX 78746-6875
USA
(512) 457-7000

Tracy L McCreight
[COR LD NTC]
Gray Cary Ware & Freidenrich
1221 S Mopac Expwy
Suite 400
Austin , TX 78746-6875
USA
(512) 457-7128
512/ 457-7001

Joseph P Reid
[COR LD NTC]
[Term: 03/08/2005]
Gray Cary Ware & Freidenrich LLP
401 B Street, Suite 2000
San Diego , CA 92101-4240
USA
(619) 699-2800
(619) 699-2701

John Allcock
[COR LD NTC]
Gray Cary Ware & Freidenrich, LLP
401 B Street
Suite 2000
San Diego , CA 92101-4240
USA
(619) 699-2828
(619) 699-2701

John E Giust
[COR LD NTC]
[Term: 03/08/2005]

Gray Cary Ware & Freidenrich, LLP
 401 B Street
 Suite 2000
 San Diego , CA 92101-4240
 USA
 (619) 699-2828
 (619) 699-2701

Matthew C Bernstein
 [COR LD NTC]
 [Term: 03/08/2005]
 Gray Cary Ware & Freidenrich, LLP
 401 B Street
 Suite 2000
 San Diego , CA 92101-4240
 USA
 (619) 699-2828
 619/ 699-2701

John Michael Guaragna
 512/457-7001
 Dia Piper Rudnick Gray Cary US
 LLP
 1221 South Mopac Expressway
 Suite 400
 Austin , TX 78746
 USA
 (512) 457-7125

Date	#	Proceeding Text
10/17/2003	--	Case assigned to Honorable Sam Sparks (sh) [Entry date 10/20/03]
10/17/2003	1	Complaint filed. Filing Fee: \$ 150.00 Receipt # 357883 (Pages: 5) (sh) [Entry date 10/20/03]
10/17/2003	--	Court file forwarded to Judge Sparks (gr) [Entry date 10/21/03]
10/17/2003	--	Notified Commissioner of Patents and Trademarks of filing complaint for patent infringement (gr) [Entry date 10/21/03]
10/17/2003	--	AO 120 forwarded to the Commissioner of Patents and Trademarks. (mc2) [Entry date 03/23/04]
10/23/2003	--	Summons issued for Dot Hill Systems Cor (gr) [Entry date 10/23/03]
10/23/2003	--	Summons issued for Dot Hill Systems Cor (gr) [Entry date 10/24/03]
11/03/2003	2	Return of service executed as to Dot Hill Systems Cor on 10/27/03 (td) [Entry date 11/04/03]
12/01/2003	3	Motion by Dot Hill Systems Cor for atty. Daniel S. Mount to appear pro hac vice (gr) [Entry date 12/02/03]
12/01/2003	4	Motion by Dot Hill Systems Cor for atty, Lara J. Hodgson to appear pro hac vice (gr) [Entry date 12/02/03]
12/01/2003	5	Motion by Dot Hill Systems Cor for atty, Alfredo A. Bismonte to appear pro hac vice (gr) [Entry date 12/02/03]
12/01/2003	6	Motion by Crossroads Systems (, Dot Hill Systems Cor to extend time to answer or otherwise respond, including motions under Rule 12 of the Fed. R (gr) [Entry date 12/02/03]
12/03/2003	7	Order granting motion for atty. Daniel S. Mount to appear pro hac vice [3-1] signed by Honorable Sam Sparks (gr) [Entry date 12/03/03]
12/03/2003	8	Order granting motion for atty, Lara J. Hodgson to appear pro hac vice [4-1] signed by Honorable Sam Sparks (gr) [Entry date 12/03/03]
12/03/2003	9	Order granting motion for atty, Alfredo A. Bismonte to appear pro hac vice [5-1] signed by Honorable Sam Sparks (gr) [Entry date 12/03/03]
12/04/2003	10	Order granting motion to extend time to answer or otherwise respond, including motions under Rule 12 of the Fed. R; until 12/17/03 [6-1] signed by Honorable Sam Sparks (gr) [Entry date 12/04/03]
12/15/2003	11	Motion by Crossroads Systems (for atty. John E. Giust to appear pro hac vice (gr) [Entry date 12/16/03]
12/15/2003	12	Motion by Crossroads Systems (for atty. Matthew C. Bernstein to appear pro hac vice (gr) [Entry date 12/16/03]
12/15/2003	13	Motion by Crossroads Systems (for atty John Allcock to appear pro hac vice (gr) [Entry date

		12/16/03]
12/16/2003	17	Answer to complaint and counterclaim by Dot Hill Systems Cor against Crossroads Systems (gr) [Entry date 12/17/03]
12/17/2003	14	Order granting motion for atty John Allcock to appear pro hac vice [13-1] signed by Honorable Sam Sparks (gr) [Entry date 12/17/03]
12/17/2003	15	Order granting motion for atty. John E. Giust to appear pro hac vice [11-1] signed by Honorable Sam Sparks (gr) [Entry date 12/17/03]
12/17/2003	16	Order granting motion for atty. Matthew C. Bernstein to appear pro hac vice [12-1] signed by Honorable Sam Sparks (gr) [Entry date 12/17/03]
01/05/2004	18	Reply by Crossroads Systems to Dot Hill Systems Corp counterclaim [17-2] (gr) [Entry date 01/06/04]
01/09/2004	19	Motion by Dot Hill Systems Cor for atty, John F. Sweeney to appear pro hac vice (gr) [Entry date 01/12/04]
01/09/2004	20	Motion by Dot Hill Systems Cor for atty, Kurt E. Richter to appear pro hac vice (gr) [Entry date 01/12/04]
01/09/2004	21	Motion by Dot Hill Systems Cor for atty. William S. Feiler to appear pro hac vice (gr) [Entry date 01/12/04]
01/13/2004	22	Order granting motion for atty. William S. Feiler to appear pro hac vice [21-1] signed by Honorable Sam Sparks (gr) [Entry date 01/13/04]
01/13/2004	23	Order granting motion for atty, Kurt E. Richter to appear pro hac vice [20-1] signed by Honorable Sam Sparks (gr) [Entry date 01/13/04]
01/13/2004	24	Order granting motion for atty, John F. Sweeney to appear pro hac vice [19-1] signed by Honorable Sam Sparks (gr) [Entry date 01/13/04]
01/29/2004	25	Motion by Dot Hill Systems Cor for atty Natu J. Patel to appear pro hac vice (gr) [Entry date 01/29/04]
01/29/2004	26	Motion by Dot Hill Systems Cor for atty. Jason B. Witten to appear pro hac vice (gr) [Entry date 01/29/04]
01/29/2004	27	Order granting motion for atty Natu J. Patel to appear pro hac vice [25-1] signed by Honorable Sam Sparks (gr) [Entry date 01/30/04]
01/29/2004	28	Order granting motion for atty. Jason B. Witten to appear pro hac vice [26-1] signed by Honorable Sam Sparks (gr) [Entry date 01/30/04]
01/30/2004	29	Amended Certificate of service to James B. Witten's Application to Appear Pro Hac Vice for Dot Hill Systems Cor (gr) [Entry date 02/02/04]
01/30/2004	30	Amended Certificate of service to Patel's Application to Appear Pro Hac Vice for Dot Hill Systems Cor (gr) [Entry date 02/02/04]
02/02/2004	--	Pro hac vice fee paid by John F. Sweeney with Amount: \$ 25.00 Receipt # 359220 (gr) [Entry date 02/09/04]
02/02/2004	--	Pro hac vice fee paid by William S. Feiler with Amount: \$ 25.00 Receipt # 359221 (gr) [Entry date 02/09/04]
02/02/2004	--	Pro hac vice fee paid by Kurt E. Richter with Amount: \$ 25.00 Receipt # 359222 (gr) [Entry date 02/09/04]
02/03/2004	--	Pro hac vice fee paid by Natu J. Patel with Amount: \$ 25.00 Receipt # 359298 (gr) [Entry date 02/09/04]
02/03/2004	--	Pro hac vice fee paid by Jason Brian Witten with Amount: \$ 25.00 Receipt # 359299 (gr) [Entry date 02/09/04]
02/09/2004	31	Order set scheduling conf. hearing for 2:00 2/18/04 in Courtroom 2, 1st floor signed by Honorable Sam Sparks (gr) [Entry date 02/09/04]
02/17/2004	32	Notice of attorney appearance for Dot Hill Systems Cor - notice of substitution of attorneys (Natu J. Patel, Jason B. Witten and local counsel, Travis Barton, in place of Daniel S. Mount (mc2) [Entry date 02/17/04]
02/17/2004	33	Joint Pretrial disclosures filed by Crossroads Systems (, Dot Hill Systems Cor (mc2) [Entry date 02/19/04]
02/18/2004	34	Minutes of proceedings for hearing on all pending matters conducted on 2/18/04 by Judge Sparks. Court Reporter: Lily Reznik. (mc2) [Entry date 02/19/04]
02/18/2004	--	Miscellaneous hearing on all pending matters held; parties agree to Karl Bayer as special master. (mc2) [Entry date 02/19/04] [Edit date 02/19/04]
02/18/2004	--	Oral order by Honorable Sam Sparks , setting miscellaneous hearing - Markman hearing before special master, Karl Bayer, - for 7/2/04 (mc2) [Entry date 02/19/04]
02/20/2004	35	Advisory to the court filed by Crossroads Systems (, Dot Hill Systems Cor - notice of nonopposition to

appointment of Karl Bayer as special master. (mc2) [Entry date 02/23/04]

02/23/2004 -- Case referred to Karl Bayer as special master (mc2) [Entry date 02/24/04]

02/23/2004 36 Order referring case to Karl Bayer, Special Master..., signed by Honorable Sam Sparks (mc2) [Entry date 02/24/04]

02/23/2004 37 Order setting miscellaneous hearing - Markman Hearing - for 9:00 7/2/04..., signed by Honorable Sam Sparks (mc2) [Entry date 02/24/04]

02/24/2004 38 Motion by Dot Hill Systems Cor for Franklin E. Gibbs to appear pro hac vice (mc2) [Entry date 02/26/04]

02/24/2004 39 Amended Certificate of service by Dot Hill Systems Cor re application to appear pro hac vice of Franklin Gibbs. (mc2) [Entry date 02/26/04]

02/25/2004 40 Order granting motion for Franklin E. Gibbs to appear pro hac vice [38-1] signed by Honorable Sam Sparks (mc2) [Entry date 02/26/04]

03/02/2004 41 Joint motion by Crossroads Systems (, Dot Hill Systems Cor for protective order (mc2) [Entry date 03/05/04]

03/08/2004 42 Order granting joint motion for protective order [41-1]. Agreed Protective Order filed & signed by Honorable Sam Sparks (td) [Entry date 03/09/04]

03/08/2004 43 Order regarding sealed documents signed by Honorable Sam Sparks (td) [Entry date 03/09/04]

03/08/2004 44 Motion by Crossroads Systems for leave to file first amended cmp (cmp attached to motion) (td) [Entry date 03/09/04]

03/22/2004 45 Motion by Dot Hill Systems Cor to substitute attorney - Natu Patel and Jason Witten in place of the law firm of Mount & Stoelker (mc2) [Entry date 03/23/04]

03/22/2004 46 Response by Dot Hill Systems Cor in opposition to motion for leave to file first amended cmp [44-1] (mc2) [Entry date 03/23/04]

03/24/2004 47 Notice of filing by Crossroads Systems - concise statement of alleged infringement. (mc2) [Entry date 03/25/04]

03/24/2004 48 Order granting motion for leave to file first amended cmp [44-1] signed by Honorable Sam Sparks (mc2) [Entry date 03/25/04]

03/24/2004 49 Amended complaint by Crossroads Systems, amending complaint [1-1] (Pages: 7) (mc2) [Entry date 03/25/04]

04/05/2004 50 Order granting motion to substitute attorney - Natu Patel and Jason Witten in place of the law firm of Mount & Stoelker [45-1] Natu J. Patel, Jason Brian Witten added signed by Honorable Sam Sparks (mm1) [Entry date 04/05/04]

04/07/2004 51 Supplemental Concise Statments of Alleged Infringement filed by Crossroads Systems (Re: file notice [47-1] (rg1) [Entry date 04/08/04]

04/07/2004 52 Stipulation filed by Crossroads Systems (, Dot Hill Systems Cor for leave for Dot Hill Systems Corp. to file a third party complaint against Falconstor. (mc2) [Entry date 04/08/04]

04/08/2004 53 Notice of filing Concise Statement of why the Accused Products Do Not Infringe by Dot Hill Systems Cor (rg) [Entry date 04/12/04]

04/12/2004 54 Order re opposition response [46-1], that defendants may object in motion for partial summary judgment..., signed by Honorable Sam Sparks (mc2) [Entry date 04/13/04]

04/12/2004 -- Pro hac vice fee paid byFranklin E. Gibbs with Amount: \$ 25.00, Receipt # 359723. (mc2) [Entry date 04/13/04]

04/13/2004 55 Answer by Dot Hill Systems Cor to amended complaint; jury demand (rg) [Entry date 04/14/04]

04/13/2004 55 Amended counterclaim by Dot Hill Systems Cor: counterclaim [17-2] (rg) [Entry date 04/14/04]

04/20/2004 56 Supplement filed by Dot Hill Systems Cor Re: file notice [53-1] (mc2) [Entry date 04/21/04]

04/23/2004 57 First Amended Answer by Dot Hill Systems Cor to amended complaint; jury demand and counterclaim against plaintiff. (mc2) [Entry date 04/23/04] [Edit date 04/23/04]

04/29/2004 58 Motion by Dot Hill Systems Cor for Larry E. Severin to appear pro hac vice (sm) [Entry date 04/29/04]

04/30/2004 59 Amended answer by Crossroads Systems (to counterclaim [17-2] (td) [Entry date 04/30/04]

04/30/2004 -- Letter/Correspondence by attorney for FalconStor, George B. Butts, regarding: stipulation for leave for Dot Hill Systems Corp. to file a third party complaint against FalconStor. Copy to Court 4/30/04. (mc2) [Entry date 05/03/04]

05/03/2004 60 Order granting motion for Larry E. Severin to appear pro hac vice [58-1] signed by Honorable Sam Sparks (mc2) [Entry date 05/03/04]

05/03/2004 61 Order granting stipulation [52-1], that Dot Hill Systems Corp. is granted leave to file a third party complaint against FalconStor, signed by Honorable Sam Sparks (mc2) [Entry date 05/03/04]

05/03/2004 62 Transcript filed for date of 2/18/04 (Proceedings Transcribed: scheduling conference) (Court Reporter: Lily Reznik.) (mc2) [Entry date 05/03/04]

05/05/2004 63 Minutes of proceedings for telephone conference conducted on 5/5/04 by Judge Sparks. Court Reporter: Lily Reznik. (mc2) [Entry date 05/06/04]

05/05/2004 -- Tele-conference held in chambers; Court resets Markman hearing to 8/30, 31, 2004, referred to Special Master for conference call and appropriate rescheduling of tutorial and briefing. (mc2) [Entry date 05/06/04]

05/05/2004 -- Miscellaneous hearing - Markman hearing - resetting on 8/30/04 (order on scheduling to follow by Special Master). (mc2) [Entry date 05/06/04]

05/06/2004 64 Order resetting Markmak hearing for 9:00 8/30/04, ..., signed by Honorable Sam Sparks (mc2) [Entry date 05/06/04]

05/06/2004 65 Third-party complaint by Dot Hill Systems Cor against FalconStor Software (mc2) [Entry date 05/07/04]

05/06/2004 66 Notice of filing by Dot Hill Systems Cor - corporate disclosure. (mc2) [Entry date 05/07/04]

05/06/2004 -- Summons issued for FalconStor Software (mc2) [Entry date 05/07/04]

05/07/2004 67 Return of service executed as to FalconStor Software on 5/6/04 (mc2) [Entry date 05/10/04]

05/25/2004 68 Answer by FalconStor Software to third-party complaint [65-1] (mc2) [Entry date 05/26/04]

05/25/2004 68 Crossclaim by FalconStor Software against Crossroads Systems (mc2) [Entry date 05/26/04]

05/26/2004 -- Sent letter to attorneys for Falconstor, Elliott and Stiefel, re bar status. (mc2) [Entry date 05/26/04]

05/26/2004 69 Motion by Crossroads Systems to halt Dod Hill's spoliation of evidence, and to compel production of Dot Hill's emails (with attached declaration of Tracy L. McCreight submitted and maintained under seal). (mc2) [Entry date 05/26/04] [Edit date 05/26/04]

05/26/2004 70 Motion by Crossroads Systems (to seal declaration of Tracy L. McCreight in support of plaintiff's motion to halt Dot Hill's spoliation of evidence and to compel production of Dot Hill's emails (mc2) [Entry date 05/26/04]

05/27/2004 71 Motion by FalconStor Software for Aaron Stiefel to appear pro hac vice (mc2) [Entry date 05/27/04]

05/27/2004 72 Motion by FalconStor Software for Mark J. Schildkraut to appear pro hac vice (mc2) [Entry date 05/27/04]

05/27/2004 73 Motion by FalconStor Software for Stephen J. Elliott to appear pro hac vice (mc2) [Entry date 05/27/04]

05/28/2004 74 Order granting motion for Aaron Stiefel to appear pro hac vice [71-1] signed by Honorable Sam Sparks (mc2) [Entry date 06/01/04]

05/28/2004 75 Order granting motion for Mark J. Schildkraut to appear pro hac vice [72-1] signed by Honorable Sam Sparks (mc2) [Entry date 06/01/04]

05/28/2004 76 Order granting motion for Stephen J. Elliott to appear pro hac vice [73-1] signed by Honorable Sam Sparks (mc2) [Entry date 06/01/04]

06/04/2004 77 Advisory to the court filed by Crossroads Systems (- notice of withdrawal of its motion to halt Dot Hill's spoliation of evidence and to compel production of Dod Hill's emails (mc2) [Entry date 06/07/04]

06/04/2004 -- Withdrawal motion to halt Dod Hill's spoliation of evidence [69-1], motion to compel production of Dot Hill's emails [69-2] (mc2) [Entry date 06/07/04]

06/07/2004 -- Pro hac vice fee paid byAaron Stiefel, Stephen J. Elliott, Mark J. Schildkraut with Amount: \$ 75.00, Receipt # 360516. (mc2) [Entry date 06/09/04]

06/08/2004 -- Pro hac vice fee paid byLarry E Severin with Amount: \$ 25.00, Receipt # 360528. (mc2) [Entry date 06/09/04]

06/10/2004 78 Motion by Crossroads Systems (to extend time to answer or otherwise respond (to FalconStor's Rule 14 claims) (mc2) [Entry date 06/10/04]

06/10/2004 79 Order granting motion to extend time to answer or otherwise respond (to FalconStor's Rule 14 claims) [78-1] until 6/28/04, signed by Honorable Sam Sparks (mc2) [Entry date 06/14/04]

06/16/2004 80 Order granting motion to seal declaration of Tracy L. McCreight in support of plaintiff's motion to halt Dot Hill's spoliation of evidence and to compel production of Dot Hill's emails [70-1] signed by Honorable Sam Sparks (mc2) [Entry date 06/16/04]

06/16/2004 81 Order mootng motion to compel production of Dot Hill's emails [69-2] signed by Honorable Sam Sparks (mc2) [Entry date 06/16/04]

06/18/2004 82 Order granting motion to extend time to answer or otherwise respond (to FalconStor's Rule 14 claims) [78-1] until 6/28/04, signed by Honorable Sam Sparks (mc2) [Entry date 06/21/04]

06/28/2004 87 Answer by Crossroads Systems (to crossclaim [68-1] (mc2) [Entry date 06/29/04]

06/28/2004	87	Counterclaim by Crossroads Systems against FalconStor Software (mc2) [Entry date 06/29/04]
06/29/2004	83	Motion by Dot Hill Systems Cor for leave to file - to exceed page limit in motion for summary judgment... (mc2) [Entry date 06/29/04]
06/29/2004	84	Unopposed Motion by Dot Hill Systems Cor to seal exhibits 14 and 17 accompanying Dot Hill's motion for summary judgment... (mc2) [Entry date 06/29/04]
06/29/2004	85	Motion by Dot Hill Systems Cor for summary judgment that U.S. Patent No. 6,425,035 and U.S. Patent No. 5,941,972 are invalid pursuant to 35 USC Sec. 102 and/or 103 in view of prior development of Digital Equipment Corp HSZ70 controller (with attached exhibits 14 and 17 submitted and maintained under seal) (mc2) [Entry date 06/29/04]
06/29/2004	86	Motion by Dot Hill Systems Cor request for judicial notice in support of its motion for summary judgment... (mc2) [Entry date 06/29/04]
06/30/2004	88	Order granting motion for leave to file - to exceed page limit in motion for summary judgment... [83-1] signed by Honorable Sam Sparks (mc2) [Entry date 06/30/04]
06/30/2004	89	Motion by Crossroads Systems for Joseph P. Reid to appear-pro hac vice (mc2) [Entry date 07/01/04]
06/30/2004	90	Motion by Dot Hill Systems Cor for leave to file - to supplement documents filed in support of its motion for summary judgment that U.S. Patent No. 6,425,035 and U.S. Patent No. 5,941,972 are invalid (with attached Exhibit A to Exhibit 4 of Dot Hill's summary judgment motion submitted and maintained under seal) (mc2) [Entry date 07/01/04] [Edit date 07/01/04]
06/30/2004	91	Unopposed Motion by Dot Hill Systems Cor to seal Exhibit A to Exhibit 4 accompanying Dot Hill's motion for summary judgment that U.S. Patent No. 6,425,035 and U.S. Patent No. 5,941,972 are invalid... (mc2) [Entry date 07/01/04]
07/01/2004	92	Order granting motion to seal exhibits 14 and 17 accompanying Dot Hill's motion for summary judgment... [84-1] signed by Honorable Sam Sparks (mc2) [Entry date 07/01/04]
07/02/2004	93	Motion by Crossroads Systems to extend time to respond to DOT Hill Systems Corp's msj (td) [Entry date 07/06/04]
07/06/2004	94	Order granting motion for Joseph P. Reid to appear pro hac vice [89-1] signed by Honorable Sam Sparks (mc2) [Entry date 07/07/04]
07/07/2004	95	Order granting motion to seal Exhibit A to Exhibit 4 accompanying Dot Hill's motion for summary judgment that U.S. Patent No. 6,425,035 and U.S. Patent No. 5,941,972 are invalid... [91-1] signed by Honorable Sam Sparks (mc2) [Entry date 07/07/04]
07/09/2004	96	Order granting motion to extend time to respond to DOT Hill Systems Corp's msj [93-1] until 11 days after last of depositions of Ellen Lary, Richard Lary, and Diana Hsuesh-Ying Shen is completed, signed by Honorable Sam Sparks (mc2) [Entry date 07/09/04]
07/09/2004	--	Pro hac vice fee paid by Joseph P. Reid with Amount: \$ 25.00, Receipt # 360959. (mc2) [Entry date 07/12/04]
07/16/2004	97	Notice of filing of Joint Submission of Preliminary Claim Chart by Crossroads Systems (, Dot Hill Systems Cor, FalconStor Software (dm) [Entry date 07/20/04]
07/19/2004	98	Answer by FalconStor Software to counterclaim [87-1] (mc2) [Entry date 07/21/04]
07/19/2004	98	Counterclaim by FalconStor Software against Crossroads Systems (mc2) [Entry date 07/21/04]
07/21/2004	99	Order that Dot Hill Systems retrieve from chambers posthaste boxes of reexamination petition delivered on 7/21/04, signed by Honorable Sam Sparks (mc2) [Entry date 07/21/04]
07/28/2004	100	Answer by Crossroads Systems to counterclaim [98-1] (mc2) [Entry date 07/29/04]
07/28/2004	101	Opening claim construction Brief by Dot Hill Systems Cor, FalconStor Software (mc2) [Entry date 07/29/04]
07/28/2004	102	Joint motion by Crossroads Systems, Dot Hill Systems Cor, FalconStor Software for leave to file Markman briefs in excess of page limit (mc2) [Entry date 07/29/04]
07/28/2004	103	Markman Brief by Crossroads Systems (mc2) [Entry date 07/29/04]
07/30/2004	104	Order granting joint motion for leave to file Markman briefs in excess of page limit [102-1] signed by Honorable Sam Sparks (mc2) [Entry date 08/02/04]
08/03/2004	105	Motion by Crossroads Systems to compel production of documents from Dot Hill (with attached declaration of Matthew Bernstein in support of motion filed under seal) (mc2) [Entry date 08/04/04]
08/03/2004	106	Unopposed Motion by Crossroads Systems to seal declaration of Matthew C. Bernstein in support of its motion to compel production of documents (mc2) [Entry date 08/04/04]
08/03/2004	107	Unopposed Motion by Crossroads Systems for leave to file motion to compel in excess of page limit (mc2) [Entry date 08/04/04]
08/04/2004	108	Advisory to the court filed by Dot Hill Systems Cor - notice of change of firm name; new name: Wang, Hartmann & Gibbs, P.C. (mc2) [Entry date 08/05/04]

08/04/2004	109	Order granting motion for leave to file motion to compel in excess of page limit [107-1] signed by Honorable Sam (mc2) [Entry date 08/05/04]
08/10/2004	110	Motion by Crossroads Systems (for (Barry K. Shelton) to appear pro hac vice (dm) [Entry date 08/12/04]
08/11/2004	111	Order granting motion for (Barry K. Shelton) to appear pro hac vice [110-1] signed by Honorable Sam Sparks (dm) [Entry date 08/12/04]
08/11/2004	112	Responsive Claim Construction Brief of Dot Hill Systems Cor, FalconStor Software (dm) [Entry date 08/12/04]
08/11/2004	113	Exhibits in support of the responsive claim construction brief of Dot Hill Systems Cor, FalconStor Software (dm) [Entry date 08/12/04]
08/11/2004	114	Joint motion by Crossroads Systems (, Dot Hill Systems Cor for leave to file responsive Markman brief in excess of page limit (dm) [Entry date 08/13/04]
08/11/2004	115	Response by Crossroads Systems (to Dot Hill Systems Corporation's Claim Construction brief [112-1] (dm) [Entry date 08/13/04]
08/16/2004	116	Opposition of Dot Hill Systems Corporation to Crossroads' motion to compel production of documents (with attached declaration of Matthew Bernstein in support of motion filed under seal) [105-1] (dm) [Entry date 08/17/04]
08/16/2004	117	Order granting motion to seal declaration of Matthew C. Bernstein in support of its motion to compel production of documents [106-1] signed by Honorable Sam Sparks (dm) [Entry date 08/17/04]
08/17/2004	--	Pro hac vice fee paid byBarry K. Shelton with Amount: \$ 25.00 Receipt # 361508 (dm) [Entry date 08/25/04]
08/18/2004	118	Order granting joint motion for leave to file responsive Markman brief in excess of page limit [114-1] signed by Honorable Sam Sparks (dm) [Entry date 08/18/04]
08/23/2004	119	Order granting motion for leave to file - to supplement documents filed in support of its motion for summary judgment that U.S. Patent No. 6,425,035 and U.S. Patent No. 5,941,972 are invalid [90-1] signed by Honorable Sam Sparks (dm) [Entry date 08/24/04]
08/24/2004	120	Motion by Crossroads Systems (for leave to file second amended complaint (dm) [Entry date 08/25/04]
08/24/2004	--	Received Stipulation and Order of Dismissal of Claims between Crossroads Systems (Texas), Inc. and Falconstor Software, inc. (dm) [Entry date 08/25/04]
08/27/2004	121	Order Motion hearing on motion to compel production of documents from Dot Hill (with attached declaration of Matthew Bernstein in support of motion filed under seal) [105-1] for 9:00 9/9/04 signed by Honorable Sam Sparks (dm) [Entry date 08/30/04]
08/27/2004	123	Order granting motion for leave to file second amended complaint [120-1], therefore ordered that plaintiff Crossroads Systems second amended complaint for patent infringement shall be deemed filed, served and effective as of the date below... signed by Honorable Sam Sparks (dm) [Entry date 08/30/04]
08/27/2004	124	Unopposed Motion by Crossroads Systems (for leave to file reply brief in support of motion to compel in excess of page limit (dm) [Entry date 08/30/04]
08/27/2004	125	Crossroads Systems Inc's Reply brief in support of its Motion to Compel the Production of Documents . (dm) [Entry date 08/30/04]
08/27/2004	126	Motion by Crossroads Systems (to seal declaration of Tracy L. McCreight in support of Crossroads Systems Inc.'s reply brief in support of its motion to compel the production of documents (dm) [Entry date 08/30/04]
08/27/2004	127	Sealed document, declaration of Tracy L. McCreight in support of Crossroads systems Inc.'s reply brief in support of its motion to compel the production of documents, placed in vault (dm) [Entry date 08/30/04]
08/27/2004	122	Stipulation an Order of Dismissal of Claims between Crossroads Systems Inc. and Falconstor Software, Inc. signed by Honorable Sam Sparks (dm) [Entry date 08/30/04]
08/30/2004	128	Minutes of proceedings for Markman Hearing conducted on August 30, 2004 by Judge Sparks. Court Reporter: Lily Reznik (dm) [Entry date 09/01/04] [Edit date 09/02/04]
08/30/2004	--	Miscellaneous hearing (Markman Hearing) held, parties announce ready, statements and arguments of counsel heard, testimony heard on behalf on plaintiff/defendant, witnesses sworn, evidence submitted on behalf of plaintiff/defendant, court exhibit filed, parties rest, closing argument heard, recommendations, special master will review evidence and submit draft to parties, invite briefs and submit final recommendation prior to December, parties to provide Ms. Sims with prosecution history when it becomes available. (dm) [Entry date 09/01/04]
08/30/2004	129	Minutes of proceedings for miscellaneous hearing conducted on August 30, 2004 by Judge Bayer. Court Reporter: no transcript made (dm) [Entry date 09/01/04] [Edit date 09/02/04]

08/30/2004 -- Miscellaneous hearing held, tutorial held in courtroom in absence of record (dm) [Entry date 09/01/04]

08/30/2004 130 Combined Witness and Exhibit List by Crossroads Systems (, Dot Hill Systems Cor (dm) [Entry date 09/01/04] [Edit date 09/02/04]

08/30/2004 -- Exhibits by Dot Hill Systems Cor (dm) [Entry date 09/20/04]

08/30/2004 -- Exhibits by Crossroads Systems (, Dot Hill Systems Cor (dm) [Entry date 09/20/04]

08/31/2004 131 Stipulated definitions of claim terms filed by Crossroads Systems (, Dot Hill Systems Cor (dm) [Entry date 09/01/04] [Edit date 09/02/04]

09/03/2004 132 Motion by Dot Hill Systems Cor for (Richard Frankklin Cauley) to appear pro hac vice (dm) [Entry date 09/07/04]

09/03/2004 133 Notice of Stipulation regarding Dot Hill Systems Corp.'s Axis Storage Manager and RAIDarPS Products filed by Crossroads Systems (, Dot Hill Systems Cor (dm) [Entry date 09/07/04]

09/03/2004 -- Pro hac vice fee paid by Richard Franklin Cauley with Amount: \$ 25.00 receipt #361713 (mc1) [Entry date 09/13/04]

09/07/2004 134 Order granting motion to seal declaration of Tracy L. McCreight in support of Crossroads Systems Inc.'s reply brief in support of its motion to compel the production of documents [126-1] signed by Honorable Sam Sparks (mc2) [Entry date 09/07/04]

09/07/2004 135 Order granting motion for leave to file reply brief in support of motion to compel in excess of page limit [124-1] signed by Honorable Sam Sparks (mc2) [Entry date 09/07/04]

09/09/2004 136 Minutes of proceedings for Motion hearing conducted on September 9, 2004 by Judge Sparks. Court Reporter: Lily Reznik (dm) [Entry date 09/09/04]

09/09/2004 -- Motion hearing held on following motion: Crossroads Systems Motion to Compel #105, parties announce ready, pro hac motion granted for Richard F. Cauley, statements and arguments of counsel heard, motions granted in part, supplemental briefs due by 5:00pm on October 1, responses due by 5:00pm on Oct. 15, written order forthcoming, court permits deposition of Ms. Greenburg (dm) [Entry date 09/10/04]

09/10/2004 137 Order granting motion for (Richard Frankklin Cauley) to appear pro hac vice [132-1] signed by Honorable Sam Sparks (dm) [Entry date 09/10/04]

09/10/2004 138 Transcript filed for dates of 8/30/04 (Proceedings Transcribed: Markman Hearing before Special Master Karl Bayer) (Court Reporter: L. Reznik) (mc1) [Entry date 09/13/04]

09/13/2004 139 Answer by Dot Hill Systems Cor to amended complaint; jury demand (mc1) [Entry date 09/14/04]

09/13/2004 140 Amended counterclaim by Dot Hill Systems Cor : counterclaim [17-2] (mc1) [Entry date 09/14/04]

09/14/2004 141 Transcript filed for date of 9/9/04 (Proceedings Transcribed: motion to compel hearing) (Court Reporter: Lily Reznik.) (mc2) [Entry date 09/14/04]

09/14/2004 142 Order granting in part, denying in part motion to compel production of documents from Dot Hill [105-1], and that the parties have until 5:00 p.m. on 10/1/04 to file any post-Markman hearing briefs, and they have until 5:00 p.m. on 10/15/04 to file any responses thereto, signed by Honorable Sam Sparks (mc2) [Entry date 09/14/04]

09/14/2004 143 Stipulation and Order regarding Dot Hill Systems Corporation's Axis Storage Manager and RAIDarPS Products, signed by Honorable Sam Sparks (mc2) [Entry date 09/14/04]

09/15/2004 -- Received Stipulation of Dismissal of Dot Hill System Corporation's Claims against Falconstor Software, inc. (dm) [Entry date 09/16/04]

09/17/2004 144 Stipulation of dismissal of Dot Hill System Corporation's claims against Falconstor Software, Inc. (dm) [Entry date 09/20/04]

09/17/2004 145 Motion and order by Crossroads Systems and Dot Hill Systems (regarding Crossroad's response deadline and Dot Hill Systems Cor reply deadline with respect to Dot Hill's pending motion for summary judgment (dm) [Entry date 09/20/04]

09/20/2004 146 Motion by Crossroads Systems (to compel the testimony of Diana Shen, Ellen Lary, and Richard Lary (dm) [Entry date 09/21/04]

09/20/2004 147 Motion by Crossroads Systems (to seal declaration of Barry K. Shelton in support of Crossroads Systems (Texas) Inc.'s motion to compel the testimony of Diana Shen, Ellen Lary, and Richard Lary (dm) [Entry date 09/21/04]

09/20/2004 148 Sealed document (Declaration of Barry K. Shelton in Support of Crossroads Systems (Texas), Inc.'s motion to compel the testimony of Diana Shen, Ellen Lary, and Richard Lary), placed in vault (dm) [Entry date 09/21/04]

09/23/2004 149 Order granting motion re: Crossroads' response deadline and Dot Hill's reply deadline with respect to Dot Hill's pending motion for summary judgment [145-1] signed by Honorable Sam Sparks (dm) [Entry date 09/23/04]

- 09/23/2004 150 Order granting motion to seal declaration of Barry K. Shelton in support of Crossroads Systems (Texas) Inc.'s motion to compel the testimony of Diana Shen, Ellen Lary, and Richard Lary [147-1] signed by Honorable Sam Sparks (dm) [Entry date 09/23/04]
- 09/27/2004 151 Motion by Dot Hill Systems Cor to exceed page limits for its motion for bifurcation of liability and damages/willfulness issues and brief in support thereof (dm) [Entry date 09/28/04]
- 09/27/2004 152 Motion by Dot Hill Systems Cor for bifurcation of liability and damages/willfulness issues, and brief in support thereof (dm) [Entry date 09/28/04]
- 09/27/2004 153 Response by Crossroads Systems (in opposition to motion for summary judgment that U.S. Patent No. 6,425,035 and U.S. Patent No. 5,941,972 are invalid pursuant to 35 USC Sec. 102 and/or 103 in view of prior development of Digital Equipment Corp HSZ70 controller (with attached exhibits 14 and 17 submitted and maintained under seal) [85-1] (dm) [Entry date 09/28/04]
- 09/27/2004 154 Motion by Crossroads Systems (for leave to file opposition to Dot Hill's motion for summary judgment that U.S. patent no. 6,425,035 and U.S. patent no. 5,941,972 are invalid pursuant to U.S. C. 102 and/or 103 in view of the prior development of the digital equipment corporation HSZ70 controller in excess of page limit (dm) [Entry date 09/28/04]
- 09/27/2004 155 Unopposed Motion by Crossroads Systems (to seal: Declaration of Barry K. Shelton in support of Crossroads Systems' opposition to Dot Hill's motion for summary judgment that U.S. patent no. 6,425,035 and U.S. patent no. 5,941,972 are invalid pursuant to U.S. C. 102 and/or 103 in view of the prior development of the digital equipment corporation HSZ70 controller (dm) [Entry date 09/28/04]
- 09/27/2004 156 Sealed document, Declaration of Barry K. Shelton in support of Crossroads Systems' opposition to Dot Hill's motion for summary judgment that U.S. patent no. 6,425,035 and U.S. patent no. 5,941,972 are invalid pursuant to U.S.C. 102 and/or 103 in view of the prior development of the digital equipment corporation HSZ70 controller, placed in vault (dm) [Entry date 09/28/04]
- 09/28/2004 157 Advisory to the court of certification of the Greenberg law firm, filed by Dot Hill Systems Cor (dm) [Entry date 09/29/04]
- 09/28/2004 158 Advisory to the court of certification of Morgan & Finnegan LLP, filed by Dot Hill Systems Cor (dm) [Entry date 09/29/04]
- 09/29/2004 159 Order granting motion to exceed page limits for its motion for bifurcation of liability and damages/willfulness issues and brief in support thereof [151-1] signed by Honorable Sam Sparks (dm) [Entry date 09/29/04]
- 09/29/2004 160 Motion by Dot Hill Systems Cor for (Natu J. Patel) to withdraw as attorney for defendant Dot Hill Systems Corporation (dm) [Entry date 10/01/04]
- 09/30/2004 161 Response by Dot Hill Systems Cor in opposition to motion to compel the testimony of Diana Shen, Ellen Lary, and Richard Lary [146-1] (dm) [Entry date 10/01/04]
- 09/30/2004 162 Motion by Dot Hill Systems Cor to file under seal: declaration of Jason B. Witten in support of Dot Hills' opposition to crossroads' motion to compel the testimony of Diana Shen, Ellen Lary and Richard Lary (dm) [Entry date 10/01/04]
- 09/30/2004 163 Motion by Dot Hill Systems Cor for leave to file opposition to motion to compel the testimony of Diana Shen, Ellen Lary, and Richard Lary in excess of page limit (dm) [Entry date 10/01/04]
- 09/30/2004 176 Sealed document, declaration of Jason B. Witten in support of Dot Hills' Opposition to Crossroads' motion to compel the testimony of Diana Shen, Ellen Lary and Richard Lary, placed in vault (dm) [Entry date 10/05/04]
- 10/01/2004 164 Response by Crossroads Systems (to amended counterclaim for declaratory judgment of noninfringement, invalidity and inequitable conduct [140-1] (dm) [Entry date 10/05/04]
- 10/01/2004 165 Motion by Dot Hill Systems Cor for leave to file Post Markman hearing claim construction brief of Dot Hill Systems Corporation in excess of page limit (dm) [Entry date 10/05/04]
- 10/01/2004 166 Motion by Dot Hill Systems Cor for leave to file under seal: declaration of Jason B. Witten in support of post markman hearing claim construction brief of Dot Hill Systems (dm) [Entry date 10/05/04]
- 10/01/2004 167 Sealed document, declaration of Jason B. Witten in support of post markman hearing claim construction brief of Dot Hill Systems corporation, placed in-vault (dm) [Entry date 10/05/04]
- 10/01/2004 168 Post-Hearing Markman Brief by Crossroads Systems (dm) [Entry date 10/05/04]
- 10/01/2004 169 Declaration of Barry K. Shelton in support of Crossroads Systems' post-hearing Markman Brief (doc. #176) (dm) [Entry date 10/05/04]
- 10/01/2004 170 Unopposed Motion by Crossroads Systems (for leave to file Crossroads Systems Inc.'s corrected opposition to Dot Hill Systems Corp's motion for summary judgment for invalidity of U.S. patent nos. 6,423,035 and 5,941,972 (dm) [Entry date 10/05/04]
- 10/01/2004 171 Motion by Crossroads Systems (for leave to file corrected opposition to Dot Hill's motion for summary judgment... (dm) [Entry date 10/05/04]
- 10/01/2004 172 Motion by Crossroads Systems (to file under seal: declaration of Barry K. Shelton in support of Crossroads systems' corrected opposition to Dot Hill's motion for summary judgment... (dm) [Entry

		date 10/05/04]
10/01/2004	173	Motion by Crossroads Systems (for leave to file declaration of Barry K. Shelton in support of Crossroads Systems Inc.'s corrected opposition to Dot Hill Systems Corporation's motion for summary judgment for invalidity of U.S. patent nos. 6,423,035 and 5,941,972 (dm) [Entry date 10/05/04]
10/01/2004	174	Declaration of Barry K. Shelton (in support of motion to file under seal: declaration of Barry K. Shelton in support of Crossroads systems' corrected opposition to Dot Hill's motion for summary judgment... [172-1] (dm) [Entry date 10/05/04]
10/01/2004	175	Post Markman Hearing Claim Construction Brief by Dot Hill Systems Cor (dm) [Entry date 10/05/04]
10/04/2004	177	Order granting motion for leave to file opposition to motion to compel the testimony of Diana Shen, Ellen Lary, and Richard Lary in excess of page limit [163-1] signed by Honorable Sam Sparks (dm) [Entry date 10/05/04]
10/05/2004	178	Order granting motion for leave to file Post Markman hearing claim construction brief of Dot Hill Systems Corporation in excess of page limit [165-1] signed by Honorable Sam Sparks (dm) [Entry date 10/06/04]
10/05/2004	179	Order granting motion for leave to file corrected opposition to Dot Hill's motion for summary judgment... [171-1] signed by Honorable Sam Sparks (dm) [Entry date 10/06/04]
10/05/2004	180	Order granting motion for (Natu J. Patel) to withdraw as attorney [160-1] (Terminated attorney Natu J. Patel for Dot Hill Systems Cor, attorney Natu J. Patel for Dot Hill Systems Cor, attorney Natu J. Patel for Dot Hill Systems Cor signed by Honorable Sam Sparks (dm) [Entry date 10/06/04]
10/05/2004	181	Order granting motion to file under seal: declaration of Jason B. Witten in support of Dot Hills' opposition to crossroads' motion to compel the testimony of Diana Shen, Ellen Lary and Richard Lary [162-1] signed by Honorable Sam Sparks (dm) [Entry date 10/06/04]
10/05/2004	182	Order granting filing of declaration of Barry K. Shelton in support of Crossroads Systems corrected opposition... [174-1] signed by Honorable Sam Sparks (dm) [Entry date 10/06/04]
10/05/2004	183	Order granting motion for leave to file Crossroads Systems Inc.'s corrected opposition to Dot Hill Systems Corp's motion for summary judgment for invalidity of U.S. patent nos. 6,423,035 and 5,941,972 [170-1] signed by Honorable Sam Sparks (dm) [Entry date 10/06/04]
10/05/2004	184	Order granting motion for leave to file declaration of Barry K. Shelton in support of Crossroads Systems Inc.'s corrected opposition to Dot Hill Systems Corporation's motion for summary judgment for invalidity of U.S. patent nos. 6,423,035 and 5,941,972 [173-1] signed by Honorable Sam Sparks (dm) [Entry date 10/06/04]
10/05/2004	185	Order granting motion for leave to file under seal: declaration of Jason B. Witten in support of post markman hearing claim construction brief of Dot Hill Systems [166-1] signed by Honorable Sam Sparks (dm) [Entry date 10/06/04]
10/05/2004	186	Response by Crossroads Systems (in opposition to motion for summary judgment that U.S. Patent No. 6,425,035 and U.S. Patent No. 5,941,972 are invalid pursuant to 35 USC Sec. 102 and/or 103 in view of prior development of Digital Equipment Corp HSZ70 controller (with attached exhibits 14 and 17 submitted and maintained under seal) [85-1] (dm) [Entry date 10/06/04]
10/05/2004	--	Mooted motions motion to file under seal: declaration of Barry K. Shelton in support of Crossroads systems' corrected opposition to Dot Hill's motion for summary judgment... [172-1], motion granted in order (doc. #184) (dm) [Entry date 01/28/05]
10/08/2004	187	Motion by Crossroads Systems (for leave to file its opposition to Dot Hill's motion for bifurcation of liability and damages/willfulness issues in excess of page limit (dm) [Entry date 10/12/04]
10/08/2004	188	Response by Crossroads Systems (in opposition to motion for bifurcation of liability and damages/willfulness issues, and brief in support thereof [152-1] (dm) [Entry date 10/12/04]
10/12/2004	189	Motion by Dot Hill Systems Cor for leave to file motion to stay in excess of page limit (dm) [Entry date 10/12/04]
10/12/2004	190	Motion by Dot Hill Systems Cor to stay (dm) [Entry date 10/12/04]
10/12/2004	191	Declaration of Jason B. Witten by Dot Hill Systems Cor in support of motion to stay or administratively terminate [190-1] (dm) [Entry date 10/12/04]
10/12/2004	192	Order granting motion for leave to file opposition to Dot Hill's motion for summary judgment that U.S. patent no. 6,425,035 and U.S. patent no. 5,941,972 are invalid pursuant to U.S. C. 102 and/or 103 in view of the prior development of the digital equipment corporation HSZ70 controller in excess of page limit [154-1] signed by Honorable Sam Sparks (dm) [Entry date 10/12/04]
10/12/2004	193	Order granting motion to seal: Declaration of Barry K. Shelton in support of Crossroads Systems' opposition to Dot Hill's motion for summary judgment that U.S. patent no. 6,425,035 and U.S. patent no. 5,941,972 are invalid pursuant to U.S. C. 102 and/or 103 in view of the prior development of the digital equipment corporation HSZ70 controller [155-1] signed by Honorable Sam Sparks (dm) [Entry date 10/13/04]
10/12/2004	194	Response by Crossroads Systems (in support of motion to compel the testimony of Diana Shen, Ellen

		Lary, and Richard Lary [146-1] (dm) [Entry date 10/13/04]
10/12/2004	195	Declaration of Barry K. Shelton by Crossroads Systems (in support of reply in support of its motion to compel... [194-1] (dm) [Entry date 10/13/04]
10/12/2004	196	Motion by Crossroads Systems (for leave to file its reply in support of its motion to compel the testimony of Diana Shen, Ellen Lary, and Richard Lary in excess of page limit (dm) [Entry date 10/13/04]
10/13/2004	197	Emergency Motion by Dot Hill Systems Cor to compel testimony of Crossroads' expert Paul Hodges (dm) [Entry date 10/13/04]
10/13/2004	198	Motion by Dot Hill Systems Cor for leave to appear by telephone at hearing on Dot Hill's emergency motion to compel testimony of Crossroads' expert Paul Hodges (dm) [Entry date 10/13/04]
10/13/2004	199	Amended emergency motion by Dot Hill Systems Cor : to compel amending motion to compel testimony of Crossroads' expert Paul Hodges [197-1] (dm) [Entry date 10/14/04]
10/13/2004	200	Order granting motion for leave to file motion to stay in excess of page limit [189-1] signed by Honorable Sam Sparks (dm) [Entry date 10/14/04]
10/13/2004	201	Order granting motion for leave to file its opposition to Dot Hill's motion for bifurcation of liability and damages/willfulness issues in excess of page limit [187-1] signed by Honorable Sam Sparks (dm) [Entry date 10/14/04]
10/13/2004	202	Order set miscellaneous hearing on all pending matters at 1:30 10/15/04 signed by Honorable Sam Sparks (dm) [Entry date 10/14/04]
10/14/2004	203	Order granting motion for leave to file its reply in support of its motion to compel the testimony of Diana Shen, Ellen Lary, and Richard Lary in excess of page limit [196-1] signed by Honorable Sam Sparks (dm) [Entry date 10/14/04]
10/14/2004	204	Response by Crossroads Systems (in opposition to motion to compel testimony of Crossroads' expert Paul Hodges [197-1], amended motion to compel [199-1] (dm) [Entry date 10/15/04]
10/14/2004	205	Declaration of Barry K. Shelton by Crossroads Systems (in support of opposition to Dot Hill's emergency motion to compel testimony of Crossroads' expert Paul Hodges [204-1] (dm) [Entry date 10/15/04]
10/14/2004	206	Response by Dot Hill Systems Cor in support of motion for bifurcation of liability and damages/willfulness issues, and brief in support thereof [152-1] (dm) [Entry date 10/15/04]
10/14/2004	207	Order granting motion for leave to appear by telephone at hearing on Dot Hill's emergency motion to compel testimony of Crossroads' expert Paul Hodges [198-1] signed by Honorable Sam Sparks (dm) [Entry date 10/15/04]
10/15/2004	208	Reply by Dot Hill Systems Cor to response to motion to compel testimony of Crossroads' expert Paul Hodges [197-1], amended motion to compel [199-1] (dm) [Entry date 10/15/04]
10/15/2004	209	Motion by Dot Hill Systems Cor for leave to file responsive brief to Crossroads' post-hearing markman brief in excess of page limit (dm) [Entry date 10/15/04]
10/15/2004	210	Responsive Brief by Dot Hill Systems Cor regarding: Crossroads' post-hearing markman brief [168-1] (dm) [Entry date 10/15/04]
10/15/2004	211	Minutes of proceedings for misc. hearing conducted on 10/15/04 by Judge Sparks. Court Reporter: Lily Reznik (dm) [Entry date 10/18/04]
10/15/2004	--	Miscellaneous hearing (on all pending matters) held, parties announce ready, statements and arguments of counsel heard, motion granted #146, motion denied #190, 152, and 199, written order forthcoming (dm) [Entry date 10/18/04]
10/15/2004	212	Motion by Crossroads Systems (for leave to file its reply to post markman hearing claim construction brief of Dot Hill Systems Corporation in excess of page limit (dm) [Entry date 10/18/04]
10/15/2004	213	Motion by Crossroads Systems (to file under seal: reply to post markman hearing claim construction brief of Dot Hill Systems Corporation (dm) [Entry date 10/18/04]
10/15/2004	214	Sealed document, Crossroads Systems Inc.'s reply to post markman hearing claim construction brief of Dot Hill Systems, placed in vault (dm) [Entry date 10/18/04]
10/15/2004	215	Motion by Crossroads Systems (to seal declaration of Barry K. Shelton in support of Crossroads Systems Inc.'s reply to post markman hearing claim construction brief of Dot Hill Systems Corporation (dm) [Entry date 10/18/04]
10/15/2004	216	Sealed document, declaration of Barry K. Shelton in support of Crossroads Systems Inc.'s reply to post markman hearing claim construction brief of Dot Hill Systems Corporation, placed in vault (dm) [Entry date 10/18/04]
10/18/2004	217	Order granting motion for leave to file its reply to post markman hearing claim construction brief of Dot Hill Systems Corporation in excess of page limit [212-1] signed by Honorable Sam Sparks (dm) [Entry date 10/19/04]
10/18/2004	218	Order granting motion for leave to file responsive brief to Crossroads' post-hearing markman brief in

		excess of page limit [209-1] signed by Honorable Sam Sparks (dm) [Entry date 10/19/04]
10/18/2004	219	Order denying amended motion to compel [199-1] denying motion for bifurcation of liability and damages/willfulness issues, and brief in support thereof [152-1] denying motion to stay [190-1] granting motion to compel the testimony of Diana Shen, Ellen Lary, and Richard Lary [146-1] signed by Honorable Sam Sparks (dm) [Entry date 10/19/04]
10/18/2004	--	Mooted motions motion to compel testimony of Crossroads' expert Paul Hodges [197-1] (dm) [Entry date 10/19/04]
10/19/2004	220	Motion by Crossroads Systems (for (J. Eric Elliff) to appear pro hac vice (dm) [Entry date 10/20/04]
10/20/2004	221	Order granting motion for (J. Eric Elliff) to appear pro hac vice [220-1] signed by Honorable Sam Sparks (td) [Entry date 10/21/04]
10/20/2004	222	Order granting motion to seal declaration of Barry K. Shelton in support of Crossroads Systems Inc.'s reply to post markman hearing claim construction brief of Dot Hill Systems Corporation [215-1] signed by Honorable Sam Sparks (td) [Entry date 10/21/04]
10/20/2004	223	Order granting motion to file under seal: reply to post markman hearing claim construction brief of Dot Hill Systems Corporation [213-1] signed by Honorable Sam Sparks (td) [Entry date 10/21/04]
10/25/2004	--	Pro hac vice fee paid byJ. Eric Elliff with Amount: \$ 25.00 Receipt # 362493 (dm) [Entry date 11/03/04]
11/09/2004	224	Motion by Dot Hill Systems Cor for leave to file reply to opposition to motion for summary judgment that U.S. patent no. 6,425,035 and U.S. patent no. 5,941,972 are invalid.. (dm) [Entry date 11/15/04]
11/09/2004	225	Motion by Dot Hill Systems Cor to seal declaration of Jason B. Witten in support of Dot Hill's reply to opposition to motion for summary judgment that U.S. patent no. 6,425,035 and U.S. patent no. 5,941,972 are invalid.. (dm) [Entry date 11/15/04]
11/09/2004	226	Reply Brief by Dot Hill Systems Cor regarding: motion for summary judgment that U.S. Patent No. 6,425,035 and U.S. Patent No. 5,941,972 are invalid pursuant to 35 USC Sec. 102 and/or 103 in view of prior development of Digital Equipment Corp HSZ70 controller (with attached exhibits 14 and 17 submitted and maintained under seal) [85-1] (dm) [Entry date 11/15/04]
11/09/2004	227	Declaration of Jason B. Witten by Dot Hill Systems Cor in support of motion for summary judgment that U.S. Patent No. 6,425,035 and U.S. Patent No. 5,941,972 are invalid pursuant to 35 USC Sec. 102 and/or 103 in view of prior development of Digital Equipment Corp HSZ70 controller (with attached exhibits 14 and 17 submitted and maintained under seal) [85-1] (dm) [Entry date 11/15/04]
11/10/2004	228	Order granting motion for leave to file reply to opposition to motion for summary judgment that U.S. patent no. 6,425,035 and U.S. patent no. 5,941,972 are invalid.. [224-1] signed by Honorable Sam Sparks (dm) [Entry date 11/15/04]
11/12/2004	229	Motion by Dot Hill Systems Cor for leave to file corrected reply brief in support of Dot Hill's motion for summary judgment that U.S. patent no. 6,425,035 and U.S. patent no. 5,941,972 are invalid... (dm) [Entry date 11/15/04]
11/15/2004	230	Order granting motion to seal declaration of Jason B. Witten in support of Dot Hill's reply to opposition to motion for summary judgment that U.S. patent no. 6,425,035 and U.S. patent no. 5,941,972 are invalid.. [225-1] signed by Honorable Sam Sparks (dm) [Entry date 11/16/04]
11/16/2004	231	Order granting motion for leave to file corrected reply brief in support of Dot Hill's motion for summary judgment that U.S. patent no. 6,425,035 and U.S. patent no. 5,941,972 are invalid... [229-1] signed by Honorable Sam Sparks (dm) [Entry date 11/16/04]
11/24/2004	232	Motion by Crossroads Systems (for leave to file a surreply in opposition to DOT Hill Systems Corp.'s motion for summary judgment for invalidity of U.S. Patent # 6,423,035 and 5,941,972 (received Surreply and declaration) (mc1) [Entry date 11/29/04]
11/30/2004	233	Order granting motion for leave to file a surreply in opposition to DOT Hill Systems Corp.'s motion for summary judgment for invalidity of U.S. Patent # 6,423,035 and 5,941,972 [232-1] signed by Honorable Sam Sparks (mc2) [Entry date 11/30/04]
11/30/2004	234	Surreply - Response by Crossroads Systems (to motion for summary judgment that U.S. Patent No. 6,425,035 and U.S. Patent No. 5,941,972 are invalid pursuant to 35 USC Sec. 102 and/or in view of prior development of Digital Equipment Corp controller [85-1] (mc2) [Entry date 11/30/04]
12/02/2004	235	Motion by Dot Hill Systems Cor for leave to file Dot Hill's response to Crossroads' surreply in support of Dot Hill's motion for summary judgment (dm) [Entry date 12/06/04]
12/02/2004	236	Motion by Dot Hill Systems Cor for leave to file Dot Hill's response to Crossroads' surreply in support of Dot Hill's motion for summary judgment (dm) [Entry date 12/06/04]
12/02/2004	237	Response by Dot Hill Systems Cor to Crossroads' surreply in support of Dot Hill's motion for summary judgment [234-1] (dm) [Entry date 12/06/04]
12/10/2004	238	Order granting motion for leave to file Dot Hill's response to Crossroads' surreply in support of Dot Hill's motion for summary judgment [236-1] signed by Honorable Sam Sparks (dm) [Entry date

12/13/04]

12/10/2004 239 Order granting motion for leave to file Dot Hill's response to Crossroads' surreply in support of Dot Hill's motion for summary judgment [235-1] signed by Honorable Sam Sparks (dm) [Entry date 12/13/04]

01/05/2005 240 Notice of attorney appearance for Crossroads Systems (, by John Michael Guaragna (mc2) [Entry date 01/06/05] [Edit date 01/06/05]

01/05/2005 242 Motion by Crossroads Systems (for Raymond W. Mort, III to appear pro hac vice (mc2) [Entry date 01/06/05]

01/06/2005 241 Advisory to the court filed by Crossroads Systems (- notice of change of firm name and removal of counsel for plaintiff. (mc2) [Entry date 01/06/05]

01/07/2005 243 Order granting motion for Raymond W. Mort, III to appear pro hac vice [242-1] signed by Honorable Sam Sparks (dm) [Entry date 01/10/05]

01/13/2005 -- Pro hac vice fee paid byRaymond W. Mort with Amount: \$ 25.00 Receipt # 363826 (dm) [Entry date 01/18/05]

01/19/2005 244 Motion by Crossroads Systems (for Darius C. Gambino to appear pro hac vice (dm) [Entry date 01/20/05]

01/21/2005 245 Report and recommendation of Special Master Karl Bayer regarding United States Patent Nos. 5,941,972 and 6,425,035 B2 (dm) [Entry date 01/24/05]

01/25/2005 246 Order granting motion for Darius C. Gambino to appear pro hac vice [244-1] signed by Honorable Sam Sparks (dm) [Entry date 01/25/05]

01/26/2005 -- Acknowledgment receipt by Alan Albright magistrate report and recommendations (dm) [Entry date 01/26/05]

01/26/2005 -- Acknowledgment receipt by Raymond Mort, John Guaragna, Barry Shelton & Tacy McCreight magistrate report and recommendations (dm) [Entry date 01/26/05]

01/27/2005 -- Acknowledgment receipt of Dot Hill Systems Cor magistrate report and recommendations (td) [Entry date 01/28/05]

01/27/2005 -- Pro hac vice fee paid byDarius C. Gambino with Amount: \$ 25.00 Receipt # 364027 (dm) [Entry date 02/07/05]

01/28/2005 -- Acknowledgment receipt of Dot Hill Systems Cor magistrate report and recommendations (Morgan & Finnegan) (td) [Entry date 01/28/05]

01/31/2005 247 Stipulation and Order regarding the deadline to file objections to special master's report and recommendation regarding the construction of claims in U.S. patent ... filed by Crossroads Systems (, Dot Hill Systems Cor (dm) [Entry date 02/02/05]

01/31/2005 -- Acknowledgment receipt by J. Eric Elliff magistrate report and recommendations (dm) [Entry date 02/08/05]

01/31/2005 -- Acknowledgment receipt by Franklin Gibbs, Jason Witten, Larry Severin & Richard Cauley, magistrate report and recommendations (dm) [Entry date 02/08/05]

01/31/2005 -- Acknowledgment receipt by Valerie Greenberg, magistrate report and recommendations (dm) [Entry date 02/08/05]

01/31/2005 -- Acknowledgment receipt by Joseph Reid, Matthew Bernstein, John Guist & John Allcock, magistrate report and recommendations (dm) [Entry date 02/08/05]

02/04/2005 248 Ordered that the deadline to file and serve objections to the Special Master's Report and Recommendation is Monday, February 14, 2005 and it is further ordered that the parties' Stipulation and Order regarding the deadline to file objections to the Special Mater's Report and Recommendation [#247], which the Court construes as a motion to amend the Markman scheduling order is Denied in all other respects... signed by Honorable Sam Sparks (dm) [Entry date 02/04/05]

02/04/2005 -- Acknowledgment receipt of Darius Gambino magistrate report and recommendations (dm) [Entry date 02/08/05]

02/14/2005 249 Joint Stipulation regarding deposition limits filed by Crossroads Systems (, Dot Hill Systems Cor (mc2) [Entry date 02/14/05]

02/14/2005 250 Unopposed Motion by Dot Hill Systems Cor for leave to file Dot Hill's objections to Special Master's Report and Recommendation in excess of page limit (mc2) [Entry date 02/14/05]

02/14/2005 251 Objections to report and recommendations [245-1] by Dot Hill Systems Cor (mc2) [Entry date 02/14/05]

02/17/2005 252 Motion by Dot Hill Systems Cor for Peter O. Huang to appear pro hac vice (dm) [Entry date 02/22/05]

02/22/2005 253 Response by Crossroads Systems (to report & recommendation objection [251-1] (dm) [Entry date 02/23/05]

02/22/2005 254 Order granting motion for leave to file Dot Hill's objections to Special Master's Report and

		Recommendation in excess of page limit [250-1] signed by Honorable Sam Sparks (dm) [Entry date 02/23/05]
03/03/2005	255	Motion by Crossroads Systems (for Alan D. Albright, Barry K. Shelton, John E. Guist, Matthew C. Bernstein, Joseph Reid, and Tracy L. McCreight to withdraw as attorney (dm) [Entry date 03/04/05]
03/03/2005	256	Motion by Dot Hill Systems Cor for a limited six month abatement (dm) [Entry date 03/07/05]
03/04/2005	257	Order striking motion for Peter O. Huang to appear pro hac vice [252-1] signed by Honorable Sam Sparks (dm) [Entry date 03/07/05]
03/07/2005	258	Motion by Dot Hill Systems Cor for Peter O. Huang to appear pro hac vice (dm) [Entry date 03/08/05]
03/08/2005	259	Order granting motion for Alan D. Albright, Barry K. Shelton, John E. Guist, Matthew C. Bernstein, Joseph Reid, and Tracy L. McCreight to withdraw as attorney [255-1] (Terminated attorney Alan D Albright for Crossroads Systems (, attorney John E. Giust for Crossroads Systems (, attorney Matthew C. Bernstein for Crossroads Systems (, attorney Joseph P. Reid for Crossroads Systems (, attorney Joseph P. Reid for Crossroads Systems (, attorney Alan D Albright for Crossroads Systems (, attorney Tracy L. McCreight for Crossroads Systems (, attorney John E. Giust for Crossroads Systems (, attorney Matthew C. Bernstein for Crossroads Systems (, attorney Joseph P. Reid for Crossroads Systems (, attorney Alan D Albright for Crossroads Systems (, attorney Tracy L. McCreight for Crossroads Systems (, attorney John E. Giust for Crossroads Systems (, attorney Matthew C. Bernstein for Crossroads Systems (, attorney Joseph P. Reid for Crossroads Systems (, attorney Alan D Albright for Crossroads Systems (, attorney Tracy L. McCreight for Crossroads Systems (, attorney John E. Giust for Crossroads Systems (, attorney Matthew C. Bernstein for Crossroads Systems (, attorney Barry K. Shelton for Crossroads Systems (, attorney Joseph P. Reid for Crossroads Systems (, attorney Matthew C. Bernstein for Crossroads Systems (, attorney John E. Giust for Crossroads Systems (, attorney Tracy L. McCreight for Crossroads Systems (, attorney Alan D Albright for Crossroads Systems (signed by Honorable Sam Sparks (dm) [Entry date 03/08/05]
03/09/2005	260	Order granting motion for Peter O. Huang to appear pro hac vice [258-1] signed by Honorable Sam Sparks (dm) [Entry date 03/09/05]
03/11/2005	261	Order Motion hearing motion for a limited six month abatement [256-1] for 2:00 3/17/05, motion request for judicial notice in support of its motion for summary judgment... [86-1] for 2:00 3/17/05, motion for summary judgment that U.S. Patent No. 6,425,035 and U.S. Patent No. 5,941,972 are invalid pursuant to 35 USC Sec. 102 and/or 103 in view of prior development of Digital Equipment Corp HSZ70 controller (with attached exhibits 14 and 17 submitted and maintained under seal) [85-1] for 2:00 3/17/05 signed by Honorable Sam Sparks (dm) [Entry date 03/14/05]
03/11/2005	--	Pro hac vice fee paid by Peter O. Huang with Amount: \$ 25.00 Receipt # 379646 (dm) [Entry date 03/17/05]
03/14/2005	262	Response by Crossroads Systems (in opposition to motion for a limited six month abatement [256-1] (dm) [Entry date 03/16/05]
03/14/2005	263	Motion by Dot Hill Systems Cor for leave to supplement its motion for a limited six month abatement (dm) [Entry date 03/16/05]
03/14/2005	264	Declaration of John M. Guaragna by Crossroads Systems (in support of in opposition response [262-1] (dm) [Entry date 03/16/05]
03/15/2005	265	Transcript filed for dates of October 15, 2004 (Proceedings Transcribed: all pending matters) (Court Reporter: Lily Reznik) (dm) [Entry date 03/16/05]
03/17/2005	--	Miscellaneous hearing on all pending matters held, case will be stayed for 90 days after April 7, 2005, plaintiff to copy the patent office, at the end of 90 day period parties will proceed with discovery, etc. (dm) [Entry date 03/18/05]
03/17/2005	266	Minutes of proceedings for motions hearing conducted on March 17, 2005 by Judge Sparks. Court Reporter: Lily Reznik (dm) [Entry date 03/18/05]
03/22/2005	267	Order granting motion for leave to supplement its motion for a limited six month abatement [263-1], granting in part, denying in part motion for a limited six month abatement [256-1], dismissing motion request for judicial notice in support of its motion for summary judgment... [86-1], dismissing motion for summary judgment that U.S. Patent No. 6,425,035 and U.S. Patent No. 5,941,972 are invalid pursuant to 35 USC Sec. 102 and/or 103 in view of prior development of Digital Equipment Corp HSZ70 controller (with attached exhibits 14 and 17 submitted and maintained under seal) [85-1] signed by Honorable Sam Sparks (dm) [Entry date 03/23/05]
03/28/2005	268	Transcript filed for dates of March 17, 2005 (Proceedings Transcribed: All Pending Matters) (Court Reporter: Lily Reznik) (dm) [Entry date 03/29/05]
04/12/2005	269	Letter/Correspondence submitted by Crossroads Systems (regarding: compliance with Court's March 22, 2005 order requesting that plaintiff file a copy of that order in the reexamination proceedings involving the patents-in-suit. (dm) [Entry date 04/13/05]
06/20/2005	270	Motion by Dot Hill Systems Cor for continued limited abatement (dm) [Entry date 06/21/05]
06/20/2005	271	Declaration of Richard F. Cauley in support of Dot Hill Systems Corporation's motion for continued limited abatement [270-1] (dm) [Entry date 06/21/05]

07/01/2005	272	Response by Crossroads Systems (in opposition to motion for continued limited abatement [270-1] (dm) [Entry date 07/05/05]
07/01/2005	273	Declaration of John M. Guaragna by Crossroads Systems (in support of opposition response [272-1] (dm) [Entry date 07/05/05]
07/07/2005	274	Response by Dot Hill Systems Cor in support of motion for continued limited abatement [270-1] (dm) [Entry date 07/08/05]
07/13/2005	275	Order set hearing on all pending matters at 2:00 7/21/05 signed by Honorable Sam Sparks (dm) [Entry date 07/14/05]
07/21/2005	--	Motion hearing held for the following motions: [270-1], announcements made, statements of counsel heard. After consideration, the Court agrees to continue the stay for 60 days. (dm) [Entry date 07/22/05]
07/21/2005	276	Minutes of proceedings for motions hearing conducted on July 21, 2005 by Judge Sparks. Court Reporter: Lily Reznik (dm) [Entry date 07/22/05]
07/26/2005	277	Order granting in part, denying in part motion for continued limited abatement [270-1], this case is stayed for an additional 60 days from the date of this order to afford the USPTO an opportunity to issue a final determination on the status of the claims of the patents-in-suit... signed by Honorable Sam Sparks (dm) [Entry date 07/26/05]
07/27/2005	278	Transcript filed for dates of July 21, 2005 (Proceedings Transcribed: Hearing on pending matters) (Court Reporter: Lily Reznik) (dm) [Entry date 07/28/05]

Copyright © 2005 LexisNexis CourtLink, Inc. All rights reserved.
*** THIS DATA IS FOR INFORMATIONAL PURPOSES ONLY ***

IN THE UNITED STATES PATENT AND TRADEMARK OFFICE	
SUBMISSION OF REFERENCES TO COMPLETE RECORD BY APPLICANTS	Atty. Docket No. (Opt.) CROSS1123-17 CROSS1123-19



71338 U.S. PTO



09/12/05

Commissioner for Patents
P.O. Box 1450
Alexandria, VA 22313

Applicants Geoffrey B. Hoese et al.	
Application Number 90/007,125 90/007,317	Filed 07/19/2004 07/19/2004
For Storage Router and Method for Providing Virtual Local Storage	
Group Art Unit 2182	Examiner Alan Chen

Certification Under 37 C.F.R. §1.8

I hereby certify that this document is being deposited with the United States Postal Service as First Class Mail in a box addressed to: Commissioner for Patents, P.O. Box 1450, Alexandria, VA 22313 on September 8, 2005.

Janice Pampell
Janice Pampell

To complete the record, Applicants respectfully submit hard copies of references previously submitted on CD-ROM with an IDS dated March 23, 2005 (the "March 23 IDS"). This submission is made simply to complete the file record and is not a new IDS as the references were already provided on CD-ROM and reviewed by Examiner Fritz Fleming (a copy of the March 23 IDS was initialed by Examiner Fleming indicating that he reviewed the references).

Respectfully submitted,

Sprinkle IP Law Group
Attorneys for Applicants

John L. Adair
John L. Adair
Reg. No. 48,828

Dated: September 8, 2005
1301 W. 25th Street, Suite 408
Austin, TX 78705
T. 512-637-9220 / F. 512-371-9088

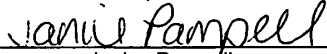

IN THE UNITED STATES PATENT AND TRADEMARK OFFICE	
SUBMISSION OF REFERENCES TO COMPLETE RECORD BY APPLICANTS	Atty. Docket No. (Opt.) CROSS1123-17 CROSS1123-19

Applicants Geoffrey B. Hoese et al.	
Application Number 90/007,125 90/007,317	Filed 07/19/2004 07/19/2004
For Storage Router and Method for Providing Virtual Local Storage	
Group Art Unit 2182	Examiner Alan Chen
Certification Under 37 C.F.R. §1.8	
I hereby certify that this document is being deposited with the United States Postal Service as First Class Mail in a box addressed to: Commissioner for Patents, P.O. Box 1450, Alexandria, VA 22313 on September 8, 2005.	
 Janice Pampell	

Commissioner for Patents
P.O. Box 1450
Alexandria, VA 22313

To complete the record, Applicants respectfully submit hard copies of references previously submitted on CD-ROM with an IDS dated March 23, 2005 (the "March 23 IDS"). This submission is made simply to complete the file record and is not a new IDS as the references were already provided on CD-ROM and reviewed by Examiner Fritz Fleming (a copy of the March 23 IDS was initialed by Examiner Fleming indicating that he reviewed the references).

Respectfully submitted,

Sprinkle IP Law Group
Attorneys for Applicants

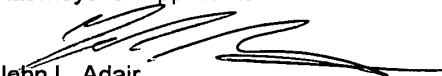
John L. Adair
Reg. No. 48,828

Dated: September 8, 2005
1301 W. 25th Street, Suite 408
Austin, TX 78705
T. 512-637-9220 / F. 512-371-9088

RE-exam

IN THE UNITED STATES PATENT AND TRADEMARK OFFICE

Statement of Substance of Examiner Interview

Atty. Docket No.
CROSS1123-17
CROSS1123-19



Applicants Geoffrey B. Hoese, et al.	
Reexamination Control No. 90/007,125 90/007,317	Date Filed 07/19/2004
Title Storage Router and Method for Providing Virtual Local Storage	
Group Art Unit 2182	Examiner Chen, Alan
Confirmation Number: 2304	Patent No. 6,425,035

Commissioner for Patents
P.O. Box 1450
Alexandria, VA 22313-1450

Dear Sir:

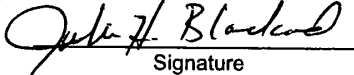
Certificate of Mailing Under 37 C.F.R. §1.10	
I hereby certify that this correspondence is being deposited with the United States Postal Service as Express Mail to Addressee (Label No. EV616963290US) in an envelope addressed to Commissioner for Patents, P.O. Box 1450, Alexandria, VA 22312-1450 on <u>9-1-05</u>	
 Signature	
<u>JULIE H. BLACKARD</u> Printed Name	

This paper is to summarize the interview conducted with Examiner Alan Chen on August 9, 2005 with Applicants' representatives including Messrs. Sprinkle, Adair and Griswold.

Summary

On August 9, 2005, Messrs. Steve Sprinkle, John Adair and Robert Griswold, Jr. met with Examiner Alan Chen for a personal interview. During the interview, the prior art cited in the Office Action Dated May 24, 2005, United States Patent 6,425,035 and the Reply to Office Action Under Ex Parte Reexamination Dated July 22, 2005 (the "July 22 Reply") submitted in the above referenced case were considered. No additional exhibits were shown or demonstrations conducted.

Applicants' representatives and Examiner Chen discussed claims 1, 7 and 11 of the 90/007,125 and 90/007,317 merged reexamination and Applicants' representatives summarized the July 22 Reply. In discussing the arguments of the July 22 Reply, Applicants' representatives reviewed the Spring and Oeda prior art references and discussed the terms "mapping", "access controls" and "remote". No agreement was reached.

This Summary was served via Certified Mail, R.R.R. on September 1, 2005 to:

Larry E. Severin
Wang, Hartmann & Gibbs, PC
1301 Dove Street, #1050
Newport Beach, CA 92660

William A. Blake
Jones, Tullar & Cooper, PC
P.O. Box 2226 Eads Station
Alexandria, VA

The Director of the U.S. Patent and Trademark Office is hereby authorized to charge any fees or credit any overpayments to Deposit Account No. 50-3183 of Sprinkle IP Law Group.

Respectfully submitted,

Sprinkle IP Law Group
Attorneys for Applicant

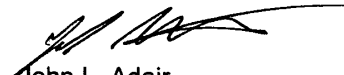
John L. Adair
Reg. No. 48,828

Date: September 1, 2005
1301 W. 25th Street, Suite 408
Austin, TX 78705
Tel. (512) 637-9223
Fax. (512) 371-9088

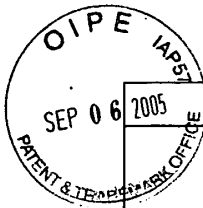

IN THE UNITED STATES PATENT AND TRADEMARK OFFICE	
CERTIFICATE OF SERVICE	Atty Docket No. CROSS1123-17 CROSS1123-19
Mail Stop Patent Application Commissioner for Patents P.O. Box 1450 Alexandria, VA 22313-1450 Sir:	Application Nos. 90/007,125 filed 07/19/2004 90/007,317 filed 11/23/2004
	Applicant: Geoffrey B. Hoese
	Title: STORAGE ROUTER AND METHOD FOR PROVIDING VIRTUAL LOCAL STORAGE

I hereby certify that the attached Statement of Substance of Examiner Interview ("Statement") is being deposited with the U.S. Postal Service as First Class Mail to the Director of the U.S. Patent Office, P.O. Box 1450, Alexandria, VA 22313 on September 1, 2005. Applicant hereby states a copy of the Notification is also being served, via first class mail (Certified, R.R.R.), on:

Larry E. Severin
Wang, Hartmann & Gibbs, PC
1301 Dove Street, #1050
Newport Beach, CA 92660

and

William A. Blake
Jones, Tullar & Cooper, PC
P.O. Box 2226 Eads Station
Alexandria, VA 22202

As per 35 U.S.C. §1.248 service is made via first class mail (Certified, R.R.R.) on September 1, 2005.

Respectfully submitted,

Sprinkle IP Law Group



John L. Adair
Reg. No. 48,828

Dated: September 1, 2005

1301 W. 25th Street, Suite 408
Austin, Texas 78705
Tel. (512) 637-9223
Fax. (512) 371-9088

Enclosures



IN THE UNITED STATES PATENT AND TRADEMARK OFFICE	
Statement of Substance of Examiner Interview	Atty. Docket No. CROSS1123-17 CROSS1123-19
Applicants Geoffrey B. Hoese, et al.	
Reexamination Control No. 90/007,125 90/007,317	Date Filed 07/19/2004
Title Storage Router and Method for Providing Virtual Local Storage	
Group Art Unit 2182	Examiner Chen, Alan
Confirmation Number: 2304	Patent No. 6,425,035

Commissioner for Patents
P.O. Box 1450
Alexandria, VA 22313-1450

Dear Sir:

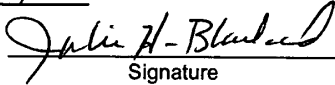
Certificate of Mailing Under 37 C.F.R. §1.10
I hereby certify that this correspondence is being deposited with the United States Postal Service as Express Mail to Addressee (Label No. EV616963290US) in an envelope addressed to Commissioner for Patents, P.O. Box 1450, Alexandria, VA 22312-1450 on <u>9-1-05</u>
 Signature
<u>JULIE H. BLACKARD</u> Printed Name

This paper is to summarize the interview conducted with Examiner Alan Chen on August 9, 2005 with Applicants' representatives including Messrs. Sprinkle, Adair and Griswold.

Summary

On August 9, 2005, Messrs. Steve Sprinkle, John Adair and Robert Griswold, Jr. met with Examiner Alan Chen for a personal interview. During the interview, the prior art cited in the Office Action Dated May 24, 2005, United States Patent 6,425,035 and the Reply to Office Action Under Ex Parte Reexamination Dated July 22, 2005 (the "July 22 Reply") submitted in the above referenced case were considered. No additional exhibits were shown or demonstrations conducted.

Applicants' representatives and Examiner Chen discussed claims 1, 7 and 11 of the 90/007,125 and 90/007,317 merged reexamination and Applicants' representatives summarized the July 22 Reply. In discussing the arguments of the July 22 Reply, Applicants' representatives reviewed the Spring and Oeda prior art references and discussed the terms "mapping", "access controls" and "remote". No agreement was reached.

This Summary was served via Certified Mail, R.R.R. on September 1, 2005 to:

Larry E. Severin
Wang, Hartmann & Gibbs, PC
1301 Dove Street, #1050
Newport Beach, CA 92660

William A. Blake
Jones, Tullar & Cooper, PC
P.O. Box 2226 Eads Station
Alexandria, VA

The Director of the U.S. Patent and Trademark Office is hereby authorized to charge any fees or credit any overpayments to Deposit Account No. 50-3183 of Sprinkle IP Law Group.

Respectfully submitted,

Sprinkle IP Law Group
Attorneys for Applicant

John L. Adair
Reg. No. 48,828

Date: September 1, 2005
1301 W. 25th Street, Suite 408
Austin, TX 78705
Tel. (512) 637-9223
Fax. (512) 371-9088

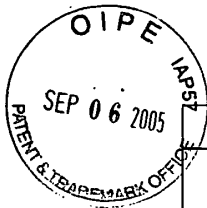

IN THE UNITED STATES PATENT AND TRADEMARK OFFICE	
CERTIFICATE OF SERVICE	Atty Docket No. CROSS1123-17 CROSS1123-19
Mail Stop Patent Application Commissioner for Patents P.O. Box 1450 Alexandria, VA 22313-1450 Sir:	Application Nos. 90/007,125 filed 07/19/2004 90/007,317 filed 11/23/2004
	Applicant: Geoffrey B. Hoese
	Title: STORAGE ROUTER AND METHOD FOR PROVIDING VIRTUAL LOCAL STORAGE

I hereby certify that the attached Statement of Substance of Examiner Interview ("Statement") is being deposited with the U.S. Postal Service as First Class Mail to the Director of the U.S. Patent Office, P.O. Box 1450, Alexandria, VA 22313 on September 1, 2005. Applicant hereby states a copy of the Notification is also being served, via first class mail (Certified, R.R.R.), on:

Larry E. Severin
Wang, Hartmann & Gibbs, PC
1301 Dove Street, #1050
Newport Beach, CA 92660

and

William A. Blake
Jones, Tullar & Cooper, PC
P.O. Box 2226 Eads Station
Alexandria, VA 22202

As per 35 U.S.C. §1.248 service is made via first class mail (Certified, R.R.R.) on September 1, 2005.

Respectfully submitted,

Sprinkle IP Law Group

John L. Adair
Reg. No. 48,828

Dated: September 1, 2005

1301 W. 25th Street, Suite 408
Austin, Texas 78705
Tel. (512) 637-9223
Fax. (512) 371-9088

Enclosures



**UNITED STATES DEPARTMENT OF COMMERCE
Patent and Trademark Office**

Address: ASSISTANT COMMISSIONER FOR PATENTS
Washington, D.C. 20231

APPLICATION NO./ CONTROL NO.	FILING DATE	FIRST NAMED INVENTOR / PATENT IN REEXAMINATION	ATTORNEY DOCKET NO.
90/007,125 90/007317	07/19/2004	6425035	1006-8910

Larry E. Severin
Wang, Hartman & Gibbs, PC
1301 Dove Street
Suite 1050
Newport Beach, CA 92660

EXAMINER

ART UNIT	PAPER
2182	

2182

DATE MAILED: 08/24/2005

Please find below and/or attached an Office communication concerning this application or proceeding.

Commissioner of Patents and Trademarks

CC: SPRINKLE IP LAW GROUP
1301 W. 25th Street
Suite 408
Austin, TX 78705

Ex Parte Reexamination Interview Summary	Control No. 90/007,125 <i>merged with 90/00817</i>	Patent Under Reexamination 6425035	
	Examiner Alan S. Chen	Art Unit 2182	

All participants (USPTO personnel, patent owner, patent owner's representative):

- (1) Alan S. Chen (3) John Adair
(2) Steve Sprinkle (4) Robert Griswold

Date of Interview: 24 August 2005

Type: a) Telephonic b) Video Conference
c) Personal (copy given to: 1) patent owner 2) patent owner's representative)

Exhibit shown or demonstration conducted: d) Yes e) No.
If Yes, brief description: _____

Agreement with respect to the claims f) was reached. g) was not reached. h) N/A.
Any other agreement(s) are set forth below under "Description of the general nature of what was agreed to..."

Claim(s) discussed: N/A.

Identification of prior art discussed: _____.

Description of the general nature of what was agreed to if an agreement was reached, or any other comments:
Examiner pointed out items of merit in references, applicant's representatives described how claims are differentiate from references.

(A fuller description, if necessary, and a copy of the amendments which the examiner agreed would render the claims patentable, if available, must be attached. Also, where no copy of the amendments that would render the claims patentable is available, a summary thereof must be attached.)

A FORMAL WRITTEN RESPONSE TO THE LAST OFFICE ACTION MUST INCLUDE PATENT OWNER'S STATEMENT OF THE SUBSTANCE OF THE INTERVIEW. (See MPEP § 2281). IF A RESPONSE TO THE LAST OFFICE ACTION HAS ALREADY BEEN FILED, THEN PATENT OWNER IS GIVEN ONE MONTH FROM THIS INTERVIEW DATE TO PROVIDE THE MANDATORY STATEMENT OF THE SUBSTANCE OF THE INTERVIEW (37 CFR 1.560(b)). THE REQUIREMENT FOR PATENT OWNER'S STATEMENT CAN NOT BE WAIVED. EXTENSIONS OF TIME ARE GOVERNED BY 37 CFR 1.550(c).

cc: Requester (if third party requester)



Examiner's signature, if required



UNITED STATES DEPARTMENT OF COMMERCE
Patent and Trademark Office

Address: ASSISTANT COMMISSIONER FOR PATENTS
Washington, D.C. 20231

APPLICATION NO./ CONTROL NO.	FILING DATE	FIRST NAMED INVENTOR / PATENT IN REEXAMINATION	ATTORNEY DOCKET NO.
90/007,125 <i>90/007,317</i>	07/19/2004	6425035	1006-8910

Larry E. Severin
Wang, Hartman & Gibbs, PC
1301 Dove Street
Suite 1050
Newport Beach, CA 92660

EXAMINER

CHEN, ALAN

ART UNIT	PAPER
2182	

2182

DATE MAILED: *08-22-05*

Please find below and/or attached an Office communication concerning this application or proceeding.

Commissioner of Patents and Trademarks

CC: SPRINKLE IP LAW GROUP
1301 W. 25th Street
Suite 408
Austin, TX 78705

Ex Parte Reexamination Interview Summary	Control No.	Patent Under Reexamination
	90/007,125 <i>merged w/ 90/007,125</i>	6425035
	Examiner <i>90/007317</i>	Art Unit
	Alan S. Chen	2182

All participants (USPTO personnel, patent owner, patent owner's representative):

- (1) Alan S. Chen (3) _____
 (2) Mr. Sprinkle (4) _____

Date of Interview: 22 August 2005

Type: a) Telephonic b) Video Conference
 c) Personal (copy given to: 1) patent owner 2) patent owner's representative)

Exhibit shown or demonstration conducted: d) Yes e) No.
 If Yes, brief description: _____

Agreement with respect to the claims f) was reached. g) was not reached. h) N/A.
 Any other agreement(s) are set forth below under "Description of the general nature of what was agreed to..."

Claim(s) discussed: N/A

Identification of prior art discussed: N/A

Description of the general nature of what was agreed to if an agreement was reached, or any other comments:
Mr. Sprinkle went over litigation/prosecution history of the patents under reexam, citing support for the lack of evidence for obviousness based on the quality and quantity of reviewers/examiners that have worked on this case. Examiner states he will put that into consideration but needs to conduct his own unbiased search/consideration in judging patentability. Examiner cites references which is not of the prior art of record that he is currently considering. Mr. Sprinkle states he would respond with feedback on them within the week.

(A fuller description, if necessary, and a copy of the amendments which the examiner agreed would render the claims patentable, if available, must be attached. Also, where no copy of the amendments that would render the claims patentable is available, a summary thereof must be attached.)

A FORMAL WRITTEN RESPONSE TO THE LAST OFFICE ACTION MUST INCLUDE PATENT OWNER'S STATEMENT OF THE SUBSTANCE OF THE INTERVIEW. (See MPEP § 2281). IF A RESPONSE TO THE LAST OFFICE ACTION HAS ALREADY BEEN FILED, THEN PATENT OWNER IS GIVEN ONE MONTH FROM THIS INTERVIEW DATE TO PROVIDE THE MANDATORY STATEMENT OF THE SUBSTANCE OF THE INTERVIEW (37 CFR 1.560(b)). THE REQUIREMENT FOR PATENT OWNER'S STATEMENT CAN NOT BE WAIVED. EXTENSIONS OF TIME ARE GOVERNED BY 37 CFR 1.550(c).

cc: Requester (if third party requester)

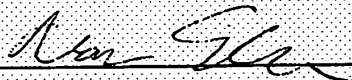
 Examiner's signature, if required



UNITED STATES PATENT AND TRADEMARK OFFICE

UNITED STATES DEPARTMENT OF COMMERCE
United States Patent and Trademark Office
Address: COMMISSIONER FOR PATENTS
P.O. Box 1450
Alexandria, Virginia 22313-1450
www.uspto.gov

APPLICATION NO.	FILING DATE	FIRST NAMED INVENTOR	ATTORNEY DOCKET NO.	CONFIRMATION NO.
90/007,317 <i>901007125</i>	11/23/2004	6425035	HOESE1/WAB	1634
44654	7590	08/09/2005	EXAMINER	
SPRINKLE IP LAW GROUP 1301 W. 25TH STREET SUITE 408 AUSTIN, TX 78705			<i>Chen, ALAN</i>	
			ART UNIT	PAPER NUMBER
			<i>2182</i>	

DATE MAILED: 08/09/2005

Please find below and/or attached an Office communication concerning this application or proceeding.



UNITED STATES DEPARTMENT OF COMMERCE
Patent and Trademark Office

Address: ASSISTANT COMMISSIONER FOR PATENTS
Washington, D.C. 20231

APPLICATION NO/ CONTROL NO.	FILING DATE	FIRST NAMED INVENTOR / PATENT IN REEXAMINATION	ATTORNEY DOCKET NO.
90/007,317 <i>90/007,125</i>	11/23/2004	6425035	HOESE1/WAB

Larry E. Severin
Wang, Hartman & Gibbs, PC
1301 Dove Street
Suite 1050
Newport Beach, CA 92660

EXAMINER

Chen, ALAN

ART UNIT	PAPER
----------	-------

2182

DATE MAILED: *08-09-05*

Please find below and/or attached an Office communication concerning this application or proceeding.

Commissioner of Patents and Trademarks

CC: SPRINKLE IP LAW GROUP
1301 W. 25th Street
Suite 408
Austin, TX 78705

Ex Parte Reexamination Interview Summary	Control No. 90/007,125 ; 90/007,317	Patent Under Reexamination 6425035	
	Examiner Alan Chen	Art Unit 2182	

All participants (USPTO personnel, patent owner, patent owner's representative):

- (1) Alan Chen (3) John Adair
(2) Steven Sprinkle (4) Robert Griswold

Date of Interview: 08/09/05

Type: a) Telephonic b) Video Conference
c) Personal (copy given to: 1) patent owner 2) patent owner's representative)

Exhibit shown or demonstration conducted: d) Yes e) No.
If Yes, brief description: _____

Agreement with respect to the claims f) was reached. g) was not reached. h) N/A.
Any other agreement(s) are set forth below under "Description of the general nature of what was agreed to..."

Claim(s) discussed: 1, 7 and 11.

Identification of prior art discussed: Spring and Oeda.

Description of the general nature of what was agreed to if an agreement was reached, or any other comments:
reviewed prior art to Spring and Oeda; deliberated over specific terms claimed, e.g., "mapping", "access control" and "remote".

(A fuller description, if necessary, and a copy of the amendments which the examiner agreed would render the claims patentable, if available, must be attached. Also, where no copy of the amendments that would render the claims patentable is available, a summary thereof must be attached.)

A FORMAL WRITTEN RESPONSE TO THE LAST OFFICE ACTION MUST INCLUDE PATENT OWNER'S STATEMENT OF THE SUBSTANCE OF THE INTERVIEW. (See MPEP § 2281). IF A RESPONSE TO THE LAST OFFICE ACTION HAS ALREADY BEEN FILED, THEN PATENT OWNER IS GIVEN ONE MONTH FROM THIS INTERVIEW DATE TO PROVIDE THE MANDATORY STATEMENT OF THE SUBSTANCE OF THE INTERVIEW (37 CFR 1.560(b)). THE REQUIREMENT FOR PATENT OWNER'S STATEMENT CAN NOT BE WAIVED. **EXTENSIONS OF TIME ARE GOVERNED BY 37 CFR 1.550(c).**



cc: Requester (if third party requester)

Examiner's signature, if required

PTOL-413A (09-04)
 Approved for use through 07/31/2006. OMB 0651-0031
 U.S. Patent and Trademark Office U.S. DEPARTMENT OF COMMERCE

Applicant Initiated Interview Request Form

Application No.: 901007,317
901007,125 First Named Applicant: Hoese
 Examiner: Chen, Alan Art Unit: 2182 Status of Application: non-final office action

Tentative Participants:
 (1) Alan Chen (2) John ADAIR
 (3) Steven Sprinkle (4) Robert Griswold

Proposed Date of Interview: August 9, 2005 Proposed Time: 2:00 (AM/PM)

Type of Interview Requested:
 (1) Telephonic (2) Personal (3) Video Conference

Exhibit To Be Shown or Demonstrated: YES NO
 If yes, provide brief description: _____

Issues To Be Discussed

Issues (Rej., Obj., etc)	Claims/ Fig. #s	Prior Art	Discussed	Agreed	Not Agreed
(1) <u>Rej</u>	<u>Claim 1</u>	<u>Spring, Deola, Tibbe</u>	<input type="checkbox"/>	<input type="checkbox"/>	<input type="checkbox"/>
(2) <u>Rej</u>	<u>Claim 7</u>	<u>"</u>	<input type="checkbox"/>	<input type="checkbox"/>	<input type="checkbox"/>
(3) <u>Rej</u>	<u>Claim 11</u>	<u>"</u>	<input type="checkbox"/>	<input type="checkbox"/>	<input type="checkbox"/>
(4) _____	_____	_____	<input type="checkbox"/>	<input type="checkbox"/>	<input type="checkbox"/>

Continuation Sheet Attached

Brief Description of Arguments to be Presented:
Spring, Deola and Tibbe do not provide access from hosts to remote storage using NLLRP. Spring, Deola and Tibbe do not teach hopping or access controls as discussed in reply dated 7/22/05. References from related exam cases, including Cruise, Cummings and DeKoning do not address missing features of Spring and Deola.

An interview was conducted on the above-identified application on _____
NOTE: This form should be completed by applicant and submitted to the examiner in advance of the interview (see MPEP § 713.01).
 This application will not be delayed from issue because of applicant's failure to submit a written record of this interview. Therefore, applicant is advised to file a statement of the substance of this interview (37 CFR 1.133(b)) as soon as possible.

 Applicant/Applicant's Representative Signature

John ADAIR
 Typed/Printed Name of Applicant or Representative

48,828
 Registration Number, if applicable

 Examiner/SPE Signature

This collection of information is required by 37 CFR 1.133. The information is required to obtain or retain a benefit by the public which is to file (and by the USPTO in process) an application. Confidentiality is governed by 35 U.S.C. 122 and 37 CFR 1.11 and 1.14. This collection is estimated to take 21 minutes to complete, including gathering, preparing, and submitting the completed application form to the USPTO. Time will vary depending upon the individual case. Any comments on the amount of time you require to complete this form and/or suggestions for reducing this burden, should be sent to the Chief Information Officer, U.S. Patent and Trademark Office, U.S. Department of Commerce, P.O. Box 1450, Alexandria, VA 22313-1450. DO NOT SEND FEES OR COMPLETED FORMS TO THIS ADDRESS. SEND TO: Commissioner for Patents, P.O. Box 1450, Alexandria, VA 22313-1450.

If you need assistance in completing the form, call 1-800-PTO-9199 and select option 2.

512 697-9220

64660 U.S. PTO



IN THE UNITED STATES PATENT AND TRADEMARK OFFICE	
CERTIFICATE OF SERVICE UNDER 37 C.F.R. 1.248	Att'y. Docket No. CROSS1123-17 CROSS1123-19
Applicant Geoffrey B. Hoese, et al.	
Reexamination Control No. 90/007,125 90/007,317	Date Filed 07/19/2004 11/23/2004
Title Storage Router and Method for Providing Virtual Local Storage	
Group Art Unit 2182	Examiner Fleming, Fritz

Applicant hereby serves the Reply to Office Action Under *Ex Parte* Reexamination Dated 05/24/05 in the above referenced case to:

Larry E. Severin
Wang, Hartmann & Gibbs, PC
1301 Dove Street, #1050
Newport Beach, CA 92660

William A. Blake
Jones, Tullar & Cooper, PC
P.O. Box 2226 Eads Station
Alexandria, VA 22202

As per 35 U.S.C. §1.248 service is made via first class mail on **July 22, 2005**

Respectfully submitted,

Sprinkle IP Law Group

John L. Adair
Reg. No. 48,828

Dated: July 22, 2005

1301 W. 25th Street, Suite 408
Austin, Texas 78705
Tel. (512) 637-9223
Fax. (512) 371-9088

Enclosures

IN THE UNITED STATES PATENT AND TRADEMARK OFFICE	
REPLY TO OFFICE ACTION UNDER <i>EX PARTE</i> REEXAMINATION DATED 05/24/05	Atty. Docket No. CROSS1123-17 CROSS1123-19
Applicants Goeffrey B. Hoese, et al.	
Reexamination Control Nos. 90/007,125 90/007,317	Date Filed 07/19/2004 01/23/2004
Title Storage Router and Method for Providing Virtual Local Storage	
Group Art Unit 2182	Examiner Fleming, Fritz

Commissioner for Patents
P.O. Box 1450
Alexandria, VA 22313-1450

Dear Sir:

<u>Certificate of Mailing Under 37 C.F.R. §1.10</u>
I hereby certify that this correspondence is being deposited with the United States Postal Service as Express Mail to Addressee (<i>Label No. EV734539513US</i>) in an envelope addressed to Commissioner for Patents, P.O. Box 1450, Alexandria, VA 22312-1450 on July 22, 2005.
 Julie Blackard

In response to the Official Action mailed May 24, 2005 (the "May 24 Office Action"), Applicant respectfully requests the Examiner reconsider the rejections of the Claims in the Re-Examination of U.S. Patent 6,425,035 (the "035 Patent") in view of this reply.

IN THE CLAIMS:

1. A storage router for providing virtual local storage on remote storage devices to devices, comprising:

a buffer providing memory work space for the storage router;

a first controller operable to connect to and interface with a first transport medium;

a second controller operable to connect to and interface with a second transport medium; and

a supervisor unit coupled to the first controller, the second controller and the buffer, the supervisor unit operable to map between devices connected to the first transport medium and the storage devices, to implement access controls for storage space on the storage devices and to process data in the buffer to interface between the first controller and the second controller to allow access from devices connected to the first transport medium to the storage devices using native low level, block protocols.

2. The storage router of claim 1, wherein the supervisor unit maintains an allocation of subsets of storage space to associated devices connected to the first transport medium, wherein each subset is only accessible by the associated device connected to the first transport medium.

3. The storage router of claim 2, wherein the devices connected to the first transport medium comprise workstations.

4. The storage router of claim 2, wherein the storage devices comprise hard disk drives.

5. The storage router of claim 1, wherein the first controller comprises:
a first protocol unit operable to connect to the first transport medium;
a first-in-first-out queue coupled to the first protocol unit; and
a direct memory access (DMA) interface coupled to the first-in-first-out queue and to the buffer.

6. The storage router of claim 1, wherein the second controller comprises:
a second protocol unit operable to connect to the second transport medium;
an internal buffer coupled to the second protocol unit; and

a direct memory access (DMA) interface coupled to the internal buffer and to the buffer of the storage router.

7. A storage network, comprising:

a first transport medium;

a second transport medium;

a plurality of workstations connected to the first transport medium;

a plurality of storage devices connected to the second transport medium; and

a storage router interfacing between the first transport medium and the second transport medium, the storage router providing virtual local storage on the storage devices to the workstations and operable:

to map between the workstations and the storage devices;

to implement access controls for storage space on the storage devices; and

to allow access from the workstations to the storage devices using native low level, block protocol in accordance with the mapping and access controls.

8. The storage network of claim 7, wherein the access controls include an allocation of subsets of storage space to associated workstations, wherein each subset is only accessible by the associated workstation.

9. The storage network of claim 7, wherein the storage devices comprise hard disk drives.

10. The storage network of claim 7, wherein the storage router comprises:

a buffer providing memory work space for the storage router;

a first controller operable to connect to and interface with the first transport medium, the first controller further operable to pull outgoing data from the buffer and to place incoming data into the buffer;

a second controller operable to connect to and interface with the second transport medium, the second controller further operable to pull outgoing data from the buffer and to place incoming data into the buffer; and

a supervisor unit coupled to the first controller, the second controller and the buffer, the supervisor unit operable:

to map between devices connected to the first transport medium and the storage devices, to implement the access controls for storage space on the storage devices and to process

data in the buffer to interface between the first controller and the second controller to allow access from workstations to storage devices.

11. A method for providing virtual local storage on remote storage devices connected to one transport medium to devices connected to another transport medium, comprising:

interfacing with a first transport medium;

interfacing with a second transport medium;

mapping between devices connected to the first transport medium and the storage devices and implementing access controls for storage space on the storage devices;

and

allowing access from devices connected to the first transport medium to the storage devices using native low level, block protocols.

12. The method of claim 11, wherein mapping between devices connected to the first transport medium and the storage devices includes allocating subsets of storage space to associated devices connected to the first transport medium, wherein each subset is only accessible by the associated device connected to the first transport medium.

13. The method of claim 12, wherein the devices connected to the first transport medium comprise workstations.

14. The method of claim 12, wherein the storage devices comprise hard disk drives.

TABLE OF CONTENTS FOR RESPONSE TO REJECTIONS

- I. Rejections Under 35 U.S.C. § 103
 - A. Introduction
 - B. Background of the Invention
 - C. Overview of Claim 1
 - D. “Remote Storage Devices” and “Allowing Access...Using NLLBPs” -
Neither Spring nor Oeda Teaches or Suggests the Limitations of Remote Storage Devices and
Allowing Access to the Remote Storage Devices Using NLLBP
 - 1. “Remote” Requires at Least One Serial Transport Medium
 - 2. Spring’s SCSI-to-SCSI System Does Not Provide Remote Storage
Devices
 - 3. Spring’s Ethernet-to-SCSI System Does Not Allow Access using
NLLBP
 - 4. Similarly, Oeda Fails to Provide Remote Storage Devices and
Allowing Access to the Remote Storage Devices Using NLLBP
 - 5. Summary: Allowing Access to Remote Storage Devices Using NLLBP
 - E. “Map” – Neither Spring or Oeda Teaches or Suggests Mapping Between
Devices Connected to the First Transport Medium and the Storage Devices
 - 1. “Map” - A Representation of the Devices on the First Transport
Medium and the Storage Devices

2. Neither Spring nor Oeda Teaches or Suggests a Map

F. "Access Controls" – Neither Spring nor Oeda Teaches or Suggests
Implementing Access Controls

1. Implementing Access Controls

2. Spring Does Not Implement Access Controls

3. Oeda Does Not Teach or Suggest Access Controls

4. The Ethernet Based Configuration of Oeda Does Not Teach or
Suggest Any Form of Access Controls for Remote Storage

G. The Combination of Oeda and Spring Does Not Teach or Suggest the
Present Invention

H. The Jibbe Reference Does Not Address the Deficiencies of Spring and
Oeda

I. Summary: There is No *Prima Facie* Case of Obviousness

II. Conclusion

I. Rejections Under 35 U.S.C. §103

A. Introduction

Claims 1-14 of the '035 Patent are variously rejected under 35 U.S.C. §103(a) as being unpatentable over United Kingdom Patent Application Publication No. UK GB 2297636 ("Spring") in view of United States Patent No. (5,634,111) ("Oeda") and further in view of United States Patent No. 5,345,565 ("Jibbe").

In order to establish a prima facie case of obviousness, the Examiner must show: that the prior art references teach or suggest all of the claim limitations; that there is some suggestion or motivation in the references (or within the knowledge of one of ordinary skill in the art) to modify or combine the references; and that there is a reasonable expectation of success. M.P.E.P. 2142, 2143; In re Vaeck, 947 F.2d 488, 20 U.S.P.Q.2d 1438 (Fed. Cir. 1991). As detailed more fully below, Applicants respectfully submit that independent Claim 1, independent Claim 7 and independent Claim 11 of the '035 Patent are not rendered obvious by Spring, Oeda or Jibbe as the references do not teach or suggest all of the claim limitations. More particularly, the references do not teach or suggest, neither individually or in combination: i) providing virtual local storage on remote storage devices and allowing access from devices connected to a first transport medium to the remote storage using native low level block protocols (NLLBP) in conjunction with; ii) mapping between devices connected to the first transport medium and the storage devices; and in conjunction with iii) implementing access controls. None of the prior art, alone or in combination, teaches or suggests all of these claimed elements.

B. Background of the Invention

The '035 Patent is directed to an efficient storage router and method of routing data over a network from devices (e.g., host computers) on one side of the storage router to remote storage devices on the other side of the storage router using low level, block storage protocols or NLLBPs. Even though the storage devices are located remotely over the network from the host computers, the storage devices are virtualized so as to appear to the host computer as locally-attached storage devices. The invention of the '035 Patent further provides the security feature of providing access controls in order to control which storage devices (or portions thereof) any particular host computer can access; this access controls feature is implemented by mapping host devices to the remote storage devices to which a host device has access. By

allowing a host device access only to those virtualized storage devices (or portions of storage devices) to which it is mapped, the invention of the '035 Patent can prevent unauthorized or unintended access by that host device to other remote storage devices in the network. Thus, the present invention provides a networked storage solution that connects hosts to remotely attached storage devices that appear locally attached, provides the security feature of controlling access to the remote storage devices using a map, and allows the host computers to access the remote storage devices over the network at the speeds and efficiencies facilitated by the use of NLLBPs.

As shown in the examples discussed in the Spring and Oeda prior art (discussed more fully below), prior to the present invention, host computers would access storage devices either i) locally via a parallel bus such as a SCSI bus or ii) remotely over a network using network protocols. However, both of these prior art systems had limitations that the invention of the '035 Patent overcomes. For storage systems with locally attached storage devices attached via SCSI buses, a SCSI-to-SCSI routing device provided access between host computers on one side of the SCSI-SCSI routing device to local storage on the other side of the SCSI-SCSI routing device. Because a SCSI bus was used on each side of the SCSI-to-SCSI routing device, a computer could access a storage device using a NLLBP, which facilitates the obtaining of information from the storage device in a fast and efficient manner (i.e., without the overhead associated with typical network file servers). However, a SCSI bus is a complicated set of parallel wires that cannot carry data a very long distance. This limitation is illustrated in Graphic 1 below. Note that color copies of Graphics 1-5 are attached in Exhibit A for the convenience of the Examiner.

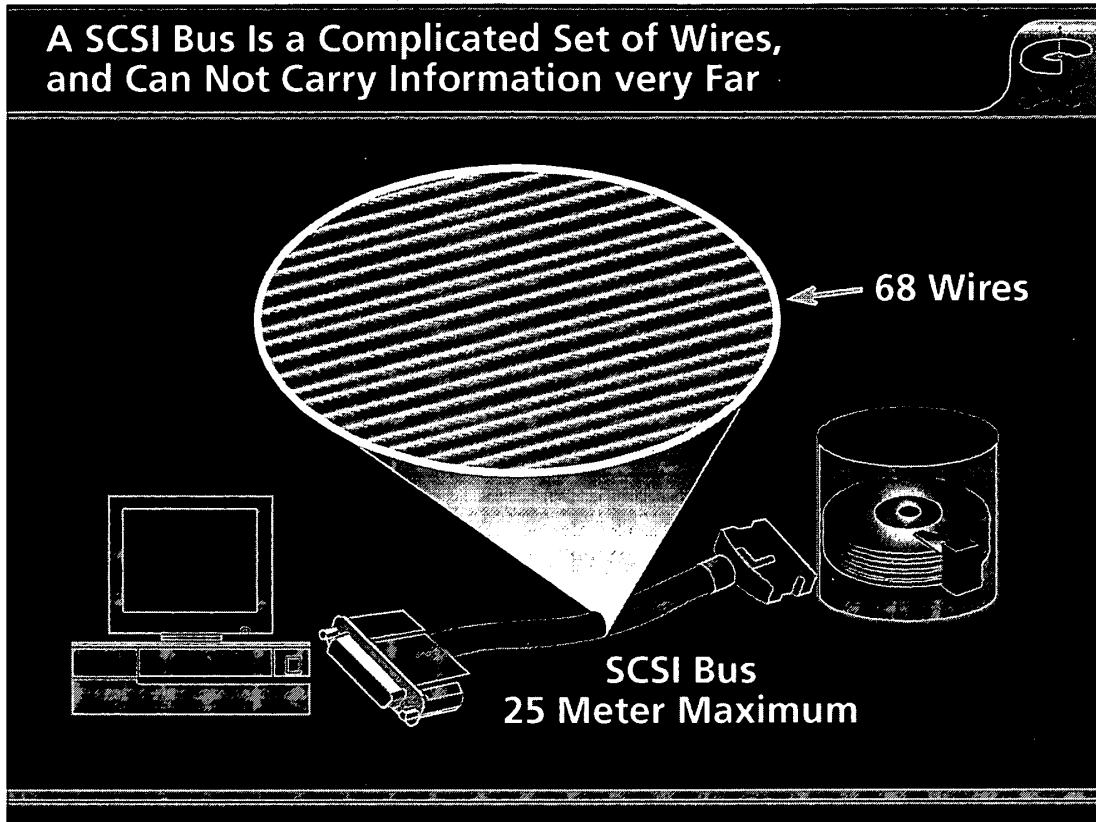

Graphic 1

Thus, a major shortcoming of any such SCSI-to-SCSI routing device or method was that the storage devices must typically be within approximately 25 meters of the host computer that needs to have access to the storage devices. Indeed, due to the costs associated with these complicated SCSI buses, most SCSI buses were significantly shorter (typically less than 12 meters) in actual installations. As the '035 Patent states "typical storage transport mediums provide for a relatively small number of devices to be attached over relatively short distances." See, '035 Patent, col. 1, lines 23-25.

Modern computer storage systems, however, need networks connecting multiple computers to each other and to remote storage locations that are significantly distant from the host computers that access the remote storage. As discussed above, this is not possible with a SCSI bus because of the distance limitation of the SCSI bus. In typical prior art systems (including those of Spring and Oeda as will be discussed below), to overcome the inability of a SCSI-to-SCSI system to provide remote storage (as discussed an NLLBP cannot be sent a long

distance over a SCSI bus), workstations were connected to a network server using a distance-capable network transport medium and a network protocol such as Ethernet. See, '035 Patent Background, col. 1, lines 47-54. A problem with this prior art solution was that the network server creates a bottleneck which slows down remote access because, at least in part, the computer or workstation needs to create something called a "network protocol" to send the data over the distance-capable transport medium. The problem with this prior art method for transmitting a storage NLLBP over a network to a remote storage device is that it takes the computer time to create a network protocol and it takes the server time to re-construct a native low level block protocol from that network protocol. Thus, the introduction of a network server into the system creates a bottleneck which slows down access to remote storage devices. Graphic 2, shown below, depicts one aspect of that bottleneck with the large balls intended to depict network protocols and the smaller balls intended to depict native low level block protocols. Although Graphic 2 only graphically depicts the problems in one direction (from the host computer through the server to the remote storage devices), the problems exist going both directions. In other words, the same type of bottleneck occurs in reverse when the data returns to the computer from the remote storage device through the server.

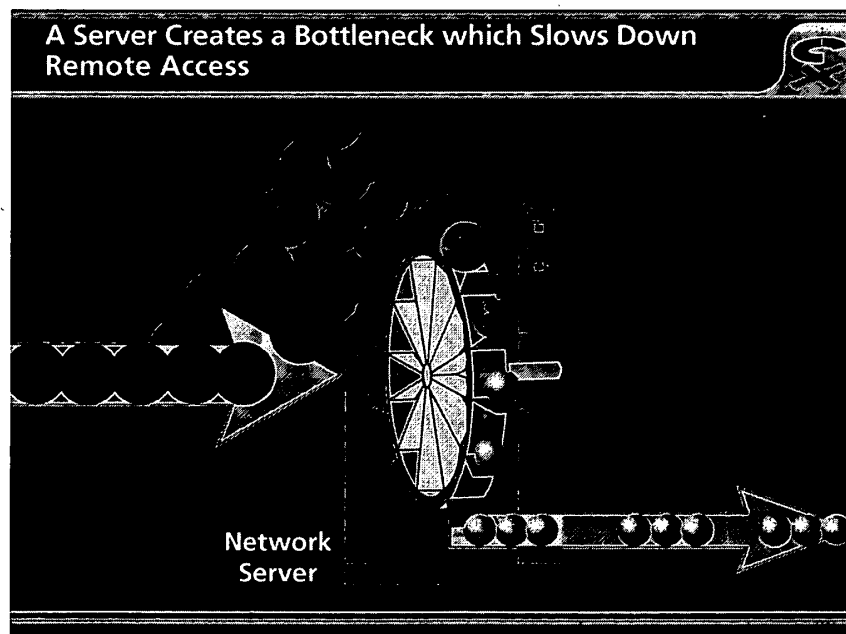

Graphic 2

As shown in Graphic 2, for prior art systems that provided hosts access to remote storage, a workstation first had to translate requests into higher level network protocols in order to communicate with the network server, and the network server would then translate the requests into low level requests (e.g., NLLBPs) for transmitting to the storage device(s). It takes a computer a long time to create a network protocol. Graphic 3, shown below, describes in general terms steps involved when a computer needs to access remote storage through a server, and has to create a network protocol to achieve that access. Similar steps occur when the computer wants to write data to the remote storage device.

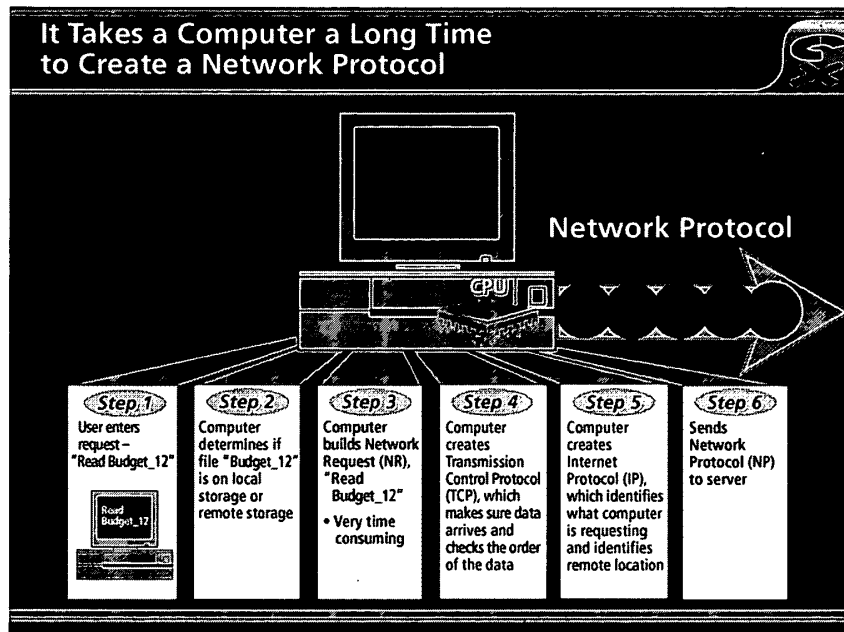

Graphic 3

As illustrated in Graphic 4 below, the process the server goes through to build a NLLBP from a network protocol is also complex and time consuming. Graphic 4 describes in general terms steps involved in building a native low level block protocol from a network protocol. The native low level block protocol is then used to access a local storage device. The return of the data from the remote storage device to the host computer also involves the same complex steps. On the return path, the server needs to build a network protocol from the NLLBP it receives from the storage device. In addition, the computer needs to process that the network

protocol to get the information by essentially repeating the steps shown in Graphic 3 above in reverse.

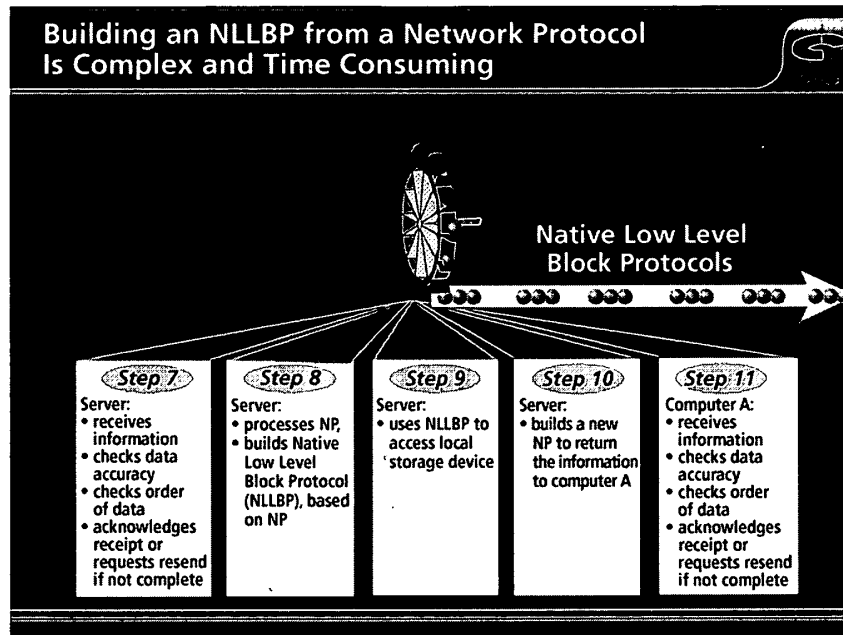

Graphic 4

Thus, prior to the present invention, those wishing to implement centralized storage at a remote location for networked devices were typically forced to use a relatively slow network server solution that required the use of higher level network protocols. These prior art systems did not provide remote storage that could be accessed at the speeds achieved by using an NLLBP from the hosts to the storage devices.

The present invention overcomes the deficiencies of these prior art systems allowing hosts to access remote storage devices at significantly distant, remote locations using a NLLBP. The use of the Fibre Channel protocol, for example, allows storage devices to be located in excess of 10 kilometers away from the workstations using a serial transport medium as opposed to the parallel transport medium of a SCSI bus. However, unlike an Ethernet file server system, a storage router connected using a Fibre Channel transport medium can allow access from the host computer to the remote storage devices using NLLBPs without having to create higher level network protocols. Because Fibre Channel supports the use of NLLBPs, the hosts can access the remote storage devices at greater speeds than can be achieved using

higher-level network protocols. The present invention thus routes NLLBPs to the remote storage devices without involving a network server that requires the use of higher-level network protocols. This allows remote storage, but does away with the time consuming and complex steps of creating and processing higher-level network protocols at a server. Consequently, both distance and speed can be achieved, without sacrificing one for the other as required by prior art solutions.

In addition to providing the ability to locate host computers remotely at significant distances from storage devices, modern storage systems need to provide security between the host computers and the remote storage. In addition, since the host computers are remotely located physically from the storage devices, it is advantageous to provide this security in a centralized manner. In other words, it is desirable to provide a centralized control mechanism that controls each host computer's access so that each host can only access particular remote storage devices (or portions thereof). In prior art systems, the ability to provide such a security mechanism in a networked system connecting hosts to remote storage devices using NLLBPs without simply did not exist.

In addition to providing hosts access to remote storage devices over a network using NLLBPs, the invention of the '035 Patent provides such a security feature. The invention of the '035 Patent contains a map that maps the host computers to the remote storage devices by associating each host computer with some or all of the remote storage devices on the other side of the storage router. The invention of the '035 Patent implements access controls by using the map to allow each host access to only the specific storage to which the host is mapped. In this manner, the invention of the '035 Patent implements access controls to limit each computer's access to a specific subset of storage devices or sections of a storage device on the other side of the storage router. Put another way, the access controls provide the capability to permit or deny each computer access to a particular storage device, a set of storage devices or portions of a single storage device or devices (or any combination thereof). By assigning storage devices or portions thereof to particular computer workstations, the present invention prevents each computer workstations from overwriting or modifying data in storage assigned to another computer workstation. This access controls feature is illustrated below in Graphic 5.

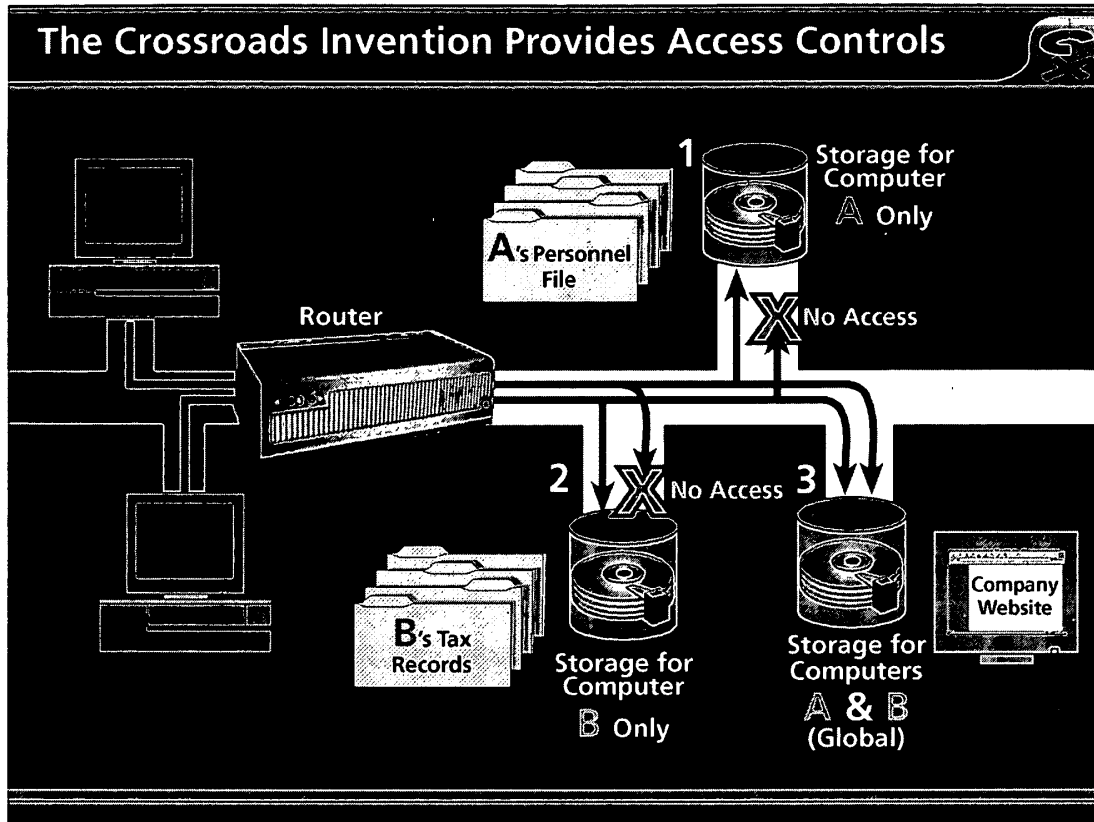

Graphic 5

For the example of Graphic 5, host computer A is mapped to remote storage device 1, host computer B is mapped to remote storage device B and both A and B are mapped to remote storage device 3. Using this map, the invention of the '035 implements access controls by allowing host computer A to access either remote storage device 1 or 3 (e.g., allow host computer A to read or write data to or from storage devices 1 or 3) and by preventing host computer A from accessing remote storage device 2 (e.g., only allowing host computer B to read or write data to storage device 2 in the example of Graphic 5). By mapping between host devices and storage devices (or portions thereof), the invention of the '035 Patent can ensure that requests from host computer A are only directed to the storage devices that are assigned to computer A. This allows the security feature of access controls to be implemented while still allowing the host computers to access the storage devices using an NLLBP.

In summary, the invention of the '035 Patent provides a networked storage solution that combines the ability to allow access from host computers to remote storage devices using NLLBPs with the ability to control access between host computers and the remote storage devices. Thus, the invention of the '035 Patent provides the advantages of 1) remote storage devices that appear to the host as locally attached, but that actually reside at remote distances from the host computers, 2) access to these remote storage devices at the speed and efficiency associated with using NLLBPs, and 3) data security by controlling the access of each host to the remote storage. None of the prior art cited by the Examiner, alone or in combination, teaches or suggests a system that provides access from host computers (or other device connected to the first transport medium) to remote storage devices using an NLLBP, while implementing access controls in accordance with a map.

C. Overview of Claim 1

The Examiner rejected independent Claim 1 as being unpatentable over Spring in view of Oeda and Jibbe. Applicants will focus on Claim 1 in discussing how the present invention differs from the cited art.

Claim 1 recites:

A storage router for providing virtual local storage on remote storage devices to devices, comprising:
a buffer providing memory work space for the storage router;
a first controller operable to connect to and interface with a first transport medium;
a second controller operable to connect to and interface with a second transport medium; and
a supervisor unit coupled to the first controller, the second controller and the buffer, the supervisor unit operable to map between devices connected to the first transport medium and the storage devices, to implement access controls for storage space on the storage devices and to process data in the buffer to interface between the first controller and the second controller to allow access from devices connected to the first transport medium to the storage devices using native low level, block protocols. [Emphasis Added].

Claim 1 includes "providing virtual local storage on remote storage devices" and "a supervisor unit . . . operable to . . . map between devices connected to the first transport

medium and the storage devices, to implement access controls for storage space on the storage devices and . . . to allow access from devices connected to the first transport medium to the storage devices using native low level, block protocols.” Claim 11 similarly includes providing virtual local storage on “remote storage devices” while claim 7 is a network containing a router that connects hosts to storage devices through transport mediums. Claims 1, 7 and 11 include features of mapping between devices on one transport medium (e.g., workstations) to the storage devices, implementing access controls and allowing access from devices connected to the first transport medium (e.g., workstations) to the storage devices using a NLLBP. The present invention as recited in Claim 1 thus enables computers to access remote storage devices without the overhead of high level protocols and file systems typically required by network servers (i.e., using NLLBP) while providing the security measure of access controls.

As will be discussed more fully below, the systems of Spring and Oeda, in contrast to the invention of the '035 Patent, either do not provide remote access to storage devices or, for embodiments of those systems that may be able to provide remote access to storage devices, require the use of higher level network protocols (and therefore cannot allow access to the remote storage devices using NLLBPs). Thus, these references suffer the shortcomings of exactly the type of prior art the present invention was designed to overcome in that they are either limited in distance or require time consuming translations between higher level network protocols and NLLBPs. Moreover, as will also be discussed more fully below, Spring and Oeda fail to disclose mapping and access controls as discussed below.

D. “Remote Storage Devices” and “Allowing Access . . . Using NLLBPs” - Neither Spring nor Oeda Teaches or Suggests the Limitations of Remote Storage Devices and Allowing Access to the Remote Storage Devices Using NLLBP

Examiner Fleming relies on Spring as showing virtual local storage on a remote storage device and both Spring and Oeda as showing the ability to allow access from devices connected to a first transport medium to a remote storage device using NLLBP. Applicants respectfully submit, however, both Spring and Oeda exhibit the shortcomings of the prior art solutions that the present invention specifically overcomes. Namely, the solutions in both Spring and Oeda require a choice between local (not remote) storage that can be accessed using a NLLBP or using slower high level network protocols to access remote storage (can't

allow access using NLLBP); neither Spring or Oeda provides a solution that allows access to remote storage devices using NLLBP.

1. "Remote" Requires at Least One Serial Transport Medium

Claim 1, as discussed above, provides virtual local storage on remote storage devices. A "remote storage device" is a storage device that is connected indirectly using at least one serial network transport medium to allow for storage devices to be significantly remote from the host computers. This definition is supported by both the Specification of the '035 Patent and by the claim construction recommended by the Special Master in currently stayed *Crossroads v. Dot Hill Systems Corporation*, Western District of Texas, Civil Action No. A-03-CA-754-SS (the "Dot Hill Litigation").

As described above, prior art solutions that allowed access from hosts to storage devices using a NLLBP used SCSI-to-SCSI routing devices. In this case, both data transport media were limited distance parallel buses (SCSI is a parallel, distance-limited bus). The present invention overcomes the deficiencies of these prior art systems allowing hosts to access centralized, remote storage devices at "significantly remote positions" using a NLLBP. See, '035 Patent, col. 2, lines 27-32. The use of the Fibre Channel protocol (a serial protocol) allows the remote storage devices to be located at distances up to and "even in excess of 10 kilometers" from the workstations. See, '035 Patent, col. 2, lines 31-33. The claimed invention of the '035 Patent provides the "ability to centralize local storage for networked workstation without any cost in speed or overhead" so that each workstation can have access to "its virtual local storage as if it were locally connected" despite potentially being at a great distance from the storage devices. See, '035 Patent col. 2, lines 27-31. In the invention of the '035 Patent, networked hosts are thus connected to storage devices over at least one significant distance-capable link, such as Fibre Channel.

As the Fibre Channel example just presented, and the other examples provided in the '035 Patent illustrate, the ability to have remote storage devices is achieved through the use of at least one serial transport medium between the workstations and the storage devices. It is the serial interconnect that allows for attachment over large distances and, hence, the ability to provide remote storage. See, '035 Patent, col. 1, lines 29-36. Even in the SCSI initiator to SCSI target configuration discussed in the '035 Patent, there is a third Fibre Channel transport medium (i.e., a serial transport medium) between the two storage routers to extend the distance between the workstations and storage devices to provide the capability for having remote

storage. See, '035 Patent col. 6, lines 19-31.¹ The serial transport medium is necessary for remote storage because parallel SCSI buses alone are severely limited in distance and cannot provide connectivity to remote storage devices in the manner of the present invention.

The definition of "remote" as requiring at least one serial transport medium is further supported by the fact that in the on-going *Crossroads v. Dot Hill Systems Corporation*, Western District of Texas, Civil Action No. A-03-CA-754-SS litigation (the "Dot Hill Litigation"), Special Master Bayer recommended to the Court that "remote" be construed to mean "indirectly connected through **at least one serial network transport medium**" (emphasis added). The pertinent portions of the Report and Recommendation of the Special Master Regarding United States Patent Nos., 5,941,972 and 6,425,035 B2 (the "Report") are attached hereto as Exhibit B. Special Master Bayer was commissioned by the Court in the Dot Hill Litigation to conduct a Markman hearing and provide recommendations to the Court as to how the claims of the '035 Patent should be interpreted. Special Master Bayer filed his recommendations in the Report after reviewing the initial Markman briefs submitted by both Dot Hill and Crossroads, conducting a Markman hearing (on August 30, 2004), and reviewing post-Markman briefs and reply briefs. After careful review and analysis, Special Master Bayer concluded that "remote" meant "indirectly connected through at least one serial network transport medium". Thus, at least one of the transport mediums (either the one connecting workstations to the storage router or the one connecting the storage router to the storage devices) recited in independent Claims 1 and 11 must be serial (e.g., cannot be parallel SCSI). This definition of "remote" is consistent with the idea that the invention of the '035 Patent allows for the storage devices to be at "significantly remote positions" of up to and "even in excess of 10 kilometers" from the hosts accessing those storage devices. The at least one serial connection allows for networked workstations to connect to storage remotely, while a parallel SCSI connection simply cannot.

¹ In this unclaimed configuration, there are two "back to back" FC-SCSI routers. Workstations are connected to the first router by a SCSI bus and storage devices are connected to the second router by a SCSI bus. The two routers are connected by a Fibre Channel transport medium.

2. Spring's SCSI-to-SCSI System Does Not Provide Remote Storage Devices

The system of Spring does not provide virtual local storage on remote storage devices. Instead, Spring teaches a system in which a server emulates local drives as local SCSI removable drives to a set of workstations. See, Spring, page 3, lines 1-5. Workstations access the emulated SCSI removable drives as if they were locally attached removable SCSI drives. See, Spring, page 10, lines 1-3. Because the drives appear as removable drives, the SCSI dismount command can be used to free media for use by other workstations. See, Spring, page 10, lines 16-25. As an example, in the context of a workgroup that works on large files, such as graphics, this allows one user to mount the virtual drive containing a particular image at the user's workstation, work on the image, save the image, and then dismount the virtual media. Another user can then mount virtual media and edit the media. This obviates the need to share physical media such as CD's or tapes while coordinating operations between various workstations.

The invention of Spring is illustrated in FIGURE 1 of Spring, reproduced below.

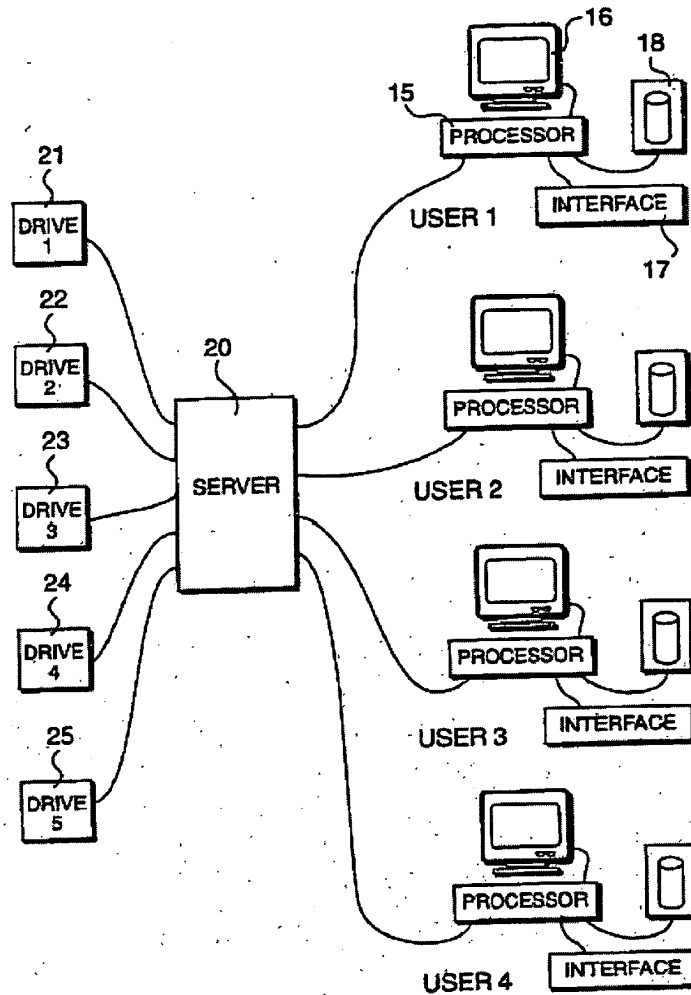

FIGURE 1 of Spring

As shown, the hosts 16 connect via a parallel SCSI bus to server 20 which is further connected to storage devices 21-25. It is clear from the Specification of Spring that the physical drives to which the data is written and from which the data is read are connected using a direct connection, specifically SCSI. Spring repeatedly mentions that the disk drives are implemented in accordance with the RAID 5 configuration. See e.g., Spring, page 6, lines 1-4,

and page 10, lines 1-5. In 1995, the year of Spring's filing, RAID 5 systems predominately if not exclusively used SCSI drives.² More significantly, Spring stresses that the differences between the emulated drives and physical drives are that the emulated SCSI drives are smaller than the physical drives and the emulated SCSI drives appear as removable while the physical drives are fixed drives. See, Spring, page 8, lines 18-23. Spring does not differentiate the SCSI emulated drives from the physical drives based on protocol and provides no ability to convert between storage protocols. Furthermore, this passage indicates that the physical drives are physically fixed and remain permanently in place. *Id.* Accordingly, Examiner Fleming stated that the system of Spring provides access from the USERS (i.e., host computers) through the server and to the disk drives using SCSI. See, May 24 Office Action, page 7 ("SCSI . . . is used from the USER to the storage router to the disc drives").

The Spring SCSI-to-SCSI system, such as that shown in FIGURE 1 of Spring, does not use at least one serial data transport medium and does not provide the capability to locate storage devices at significant distances from the workstations. There is simply no distance-capable storage link in the system of Spring as Spring relies on distance-limited SCSI interfaces. Indeed, Spring recognizes the inability of SCSI interfaces to provide a distance-capable link stating "a large number of workstations may be provided relatively close to server 20, in which case conventional SCSI interfaces may be employed." See, Spring, page 7, lines 10-12 (emphasis added). Thus, the SCSI-to-SCSI system of Spring does not provide virtual local storage on "remote storage devices" as it lacks at least one distance-capable serial transport medium.

3. Spring's Ethernet-to-SCSI System Does Not Allow Access using NLLBP

While the Spring SCSI-to-SCSI system of FIGURE 1 does not provide for remote storage devices and cannot allow for significant physical distance between the hosts and storage devices, Spring does provide some insight as to how "remote" or physically distant storage devices could be incorporated into the Spring system. While acknowledging that parallel SCSI interfaces have "limited" range, Spring states that in order to create less limited distance separation from hosts to storage devices "in alternative embodiments it may be

² Similar to SCSI, other existing drive connections such as ATA and IDE were severely limited in distance.

necessary to provide alternative connections, possibly via coaxial cables, so as to increase the distance between the server and the workstations". See Spring, page 7, lines 3-7. Spring goes on to state that ". . . in alternative arrangements, workstations may be distributed quite widely through a building, requiring more robust connection between the processor and server 20. It is envisaged that connections of this type should allow the workstation to be displaced from the server by distances in excess of 100 meters, having characteristics similar to high speed Ethernet links." See *Id.* at page 7, lines 12-17. As will be explained more fully below, this alternative embodiment to allow "remote" storage devices in Spring does not meet the claim limitation of "allowing access" between hosts and storage devices "using NLLBPs".

Independent Claim 1 of the '035 Patent not only recites that the storage devices are "remote", but also that the supervisor unit is operable to "allow access from devices connected to the first transport medium to the storage devices using native low level block protocols." Thus, the host computers connected to the first transport medium must be able to access the remote storage devices using a NLLBP. This ability to allow access from host computers to storage devices using a NLLBP, as recited in Claim 1, requires allowing access between the host and storage device(s) using a protocol (i.e., a set of rules) that does not involve the overhead of high level protocols and file systems typically required by network servers, as supported in the '035 Patent Specification and prior litigation interpreting this claim term.

As discussed above, in systems prior to the present invention, when making a request to storage through a network server to allow access between workstations and remote storage devices, a workstation first had to translate the requests from its file system protocols to higher level network protocols in order to communicate with the network server, and the network server would then translate them into low level requests to the storage device(s). In contrast, as described in the '035 Patent, allowing a host to access storage devices using a NLLBP provides a mechanism by which communication between the host and the storage devices can be accomplished faster because there is no need to translate from a network protocol to a NLLBP. See '035 Patent Specification, col. 1, lines 47-60, col. 2, lines 12-15 and 23-26, col. 3, lines 14-25 and col. 4, lines 17-25 (distinguishing an NLLBP from higher-level protocols by contrasting the invention of the '035 Patent (allowing access using NLLBP) to prior art solutions (which allowed access using network protocols requiring translation to NLLBP)). Further, in *Crossroads v. Chaparral Network Storage, Inc.*, Western District of Texas, Civil Action No. A-00-CA-217-SS (the "Chaparral Litigation") and *Crossroads Systems (Texas), Inc., v. Pathlight Technology, Inc.*, Western District of Texas, Civil Action No. A-00CA-248-JN, the Federal

District Court issued a Joint Markman Order (the "Markman Order") interpreting "NLLBP" for the purposes of United States Patent No. 5,941,972 (the "'972 Patent", the parent to the '035 Patent) as follows: "a set of rules or standards that enable computers to exchange information and do not involve the overhead of high level protocols and file systems typically required by network servers." A copy of the Markman Order is attached hereto as Exhibit C. This construction and the validity of the '972 Patent was upheld by the Federal Circuit. A copy of the Federal Circuit decision affirming the decision of the lower court is attached hereto as Exhibit D. Thus, based on both the Specification of the '035 Patent and the Markman Order, an NLLBP is a protocol that enables the exchange of information without the overhead of high-level protocols and file systems typically required by network servers.

As claimed in the '035 Patent, allowing access from host devices to storage devices is done using NLLBPs. Using the example of a first transport medium of Fibre Channel ("FC") and second transport medium of SCSI, a FC workstation can communicate SCSI commands to a storage device using the FC protocol through the storage router. In this case, the storage router receives the FC-encapsulated SCSI commands on the FC transport medium, removes the FC encapsulation and forwards the SCSI commands to the storage devices on the SCSI data transport medium (provided the FC workstation is allowed to have such access as will be discussed more fully below). There is *no translation* of the commands from a higher level network protocol to a native, low level protocol. In other words, the storage router is not required to translate from a high level command (e.g., a file system command or function call with arguments) into a SCSI command. Rather, the storage router strips the FC layer off of the existing SCSI command and forwards the SCSI command to the storage device. Thus, when the FC host workstation is allowed to have access to the SCSI storage device, that access is accomplished using NLLBPs.

Thus, as recited in Claim 1, to "allow access from devices connected to the first transport medium to devices connected to the storage devices using native low level block protocols" requires allowing access from host computers to remote storage devices using NLLBP. Thus, due to the "remote" limitation, Claim 1 requires that at least one transport medium be a serial transport medium and due to the "NLLBP" limitation, the host computers must be allowed access to the remote storage devices using a protocol that does not involve the higher level overhead typically associated with network servers. Spring simply does not teach or suggest any system that will allow hosts to access remote storage devices using NLLBP.

As discussed above, Spring does provide an alternative embodiment to its SCSI-to-SCSI embodiment of FIGURE 1 that can allow for hosts to be separated from storage devices by distances in excess of 100 meters. See, Spring, page 7, lines 3-17. (“ . . . in alternative arrangements, workstations may be distributed quite widely through a building, requiring more robust connection between the processor and server 20. It is envisaged that connections of this type should allow the workstation to be displaced from the server by distances in excess of 100 meters, having characteristics similar to high speed Ethernet links”). The use of coaxial cable for Ethernet networks was common in 1995 (e.g., 10Base-2 and 10Base-5 Ethernet), however, these Ethernet networks required the use of high-level protocols to transmit information between a workstation and a network server. In Ethernet-to-SCSI systems such as that suggested in Spring, a workstation would first translate the request from its file system protocol to a “network protocol” (i.e., Ethernet protocol) and send the request to a network server. The network server would then translate the network protocol to a native low level protocol (i.e., SCSI) and send the low level request to the attached storage device. The problem with this type of system is exactly the problem that the ‘035 Patent described in the Background of the Invention and was designed to overcome. Namely, this type of system creates a bottleneck that slows down the access from the hosts to the remote storage devices. Because, NLLBPs cannot be sent over long distances using a SCSI bus, the workstation must create a network protocol to send requests over the Ethernet transport medium. It takes the workstation a long time to create a network protocol and takes the server time to translate the information sent according to the network protocol into a NLLBP (and visa versa when sending the information back from the storage device to the host). In such a system, data access times from the workstation to the devices are increased.

While Spring provides no guidance as to how the emulated removable SCSI drives would be accessed via Ethernet in the suggested alternative embodiment, at the time of Spring, one of ordinary skill in the art would have understood that access to remote storage via Ethernet required the use of a higher level network protocol and there no teaching or suggestion in Spring otherwise. Thus, it would be understood that the workstations of Spring use a higher level network protocol (e.g., an Ethernet file server protocol) that is then translated by the network server into a NLLBP before access to remote storage devices can be achieved. The system of Spring is exactly the type of system that the present invention was designed to overcome because the system of Spring does involve the overhead of high level protocols typically required by network servers and does require a translation of a network protocol into

SCSI commands at the network server when allowing workstations to make requests to and from storage devices. Therefore, Spring does not teach or suggest the limitation “to allow access from devices connected to the first transport medium to the [remote] storage devices using native low level, block protocols.” (emphasis added).

4. Similarly, Oeda Fails to Provide Remote Storage Devices and Allowing Access to the Remote Storage Devices Using NLLBP

Like Spring, Oeda discloses a SCSI-to-SCSI system of connecting a host computer to a storage device(s). See Oeda, FIGURES 1-5. FIGURE 4, illustrative of the Oeda system, is reproduced below.

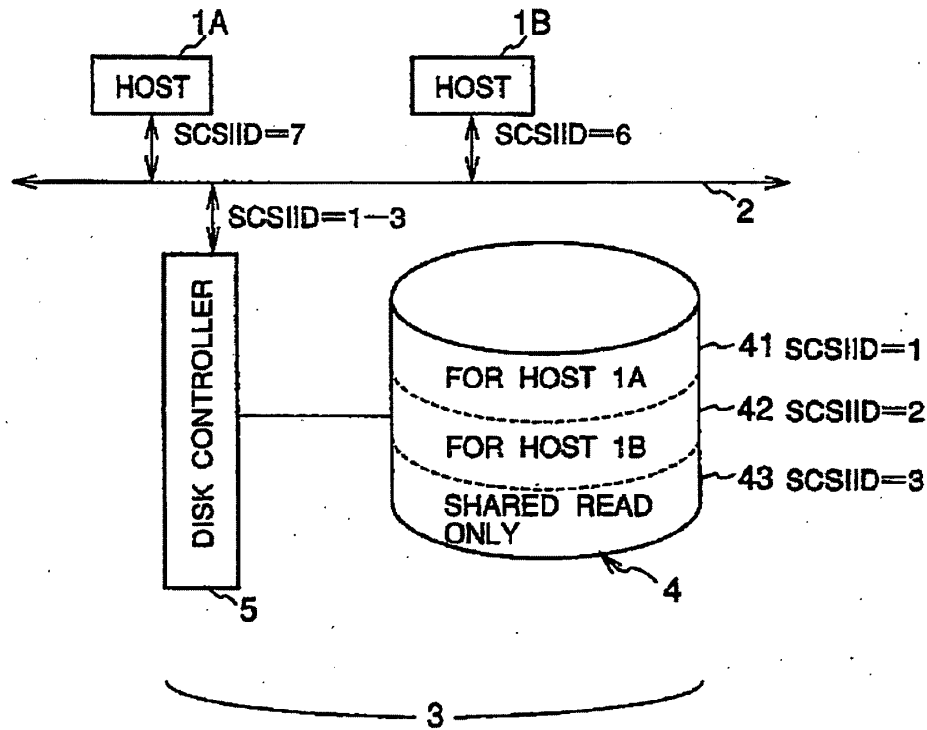

FIGURE 4 of Oeda

Using the Example of FIGURE 4 of Oeda, a SCSI magnetic disk storage device 3 (including disk controller 5 and drive unit 4) is connected to two host computers through SCSI bus 2. Thus, hosts communicate to storage devices in this Oeda system using only parallel SCSI; there is no serial transport medium between the hosts and the disk storage device. Consequently, for the reasons discussed above regarding Spring, the Oeda storage device 3 of FIGURE 4 is not remote from the host computers as recited in the independent Claims of the '035 Patent.

Like Spring, Oeda also provides an alternative embodiment that has the capability to provide hosts access to remote storage as shown in FIGURE 6 of Oeda reproduced below. Like Spring, this Oeda embodiment also fails to allow access to remote storage devices using NLLBP.

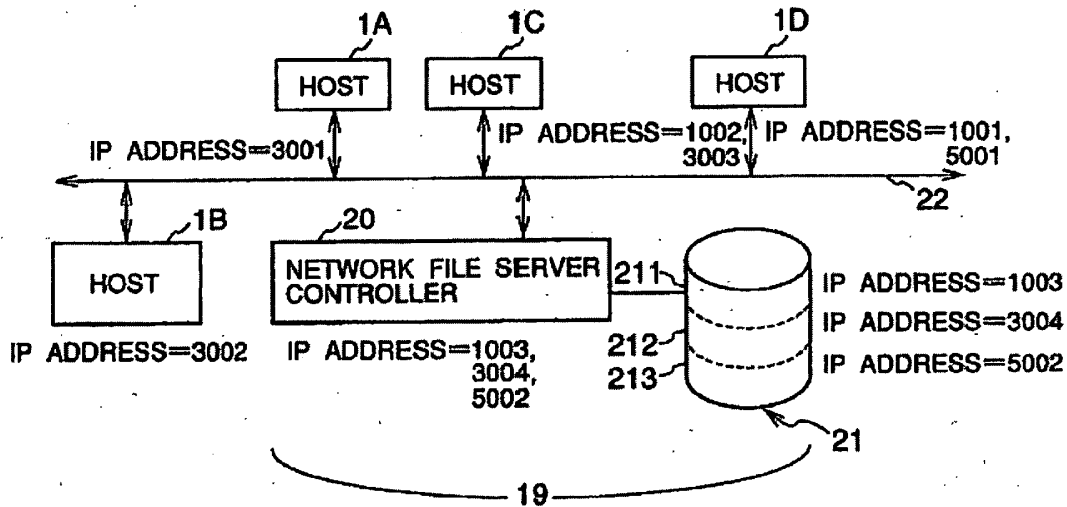

FIGURE 6 of Oeda

In FIGURE 6 of Oeda, Oeda replaces the SCSI bus 2 of FIGURE 4 with an Ethernet connection 22 and inserts into the system a network file server 19. See, Oeda, col. 9, lines 48-67 and FIGURE 6. As this embodiment of Oeda points out, access to remote storage devices required the use of higher-level network protocols and is not done using NLLBP. There is no teaching or suggestion in Oeda to the contrary. In fact, Oeda recognizes that a translation from the network protocol to a NLLBP must occur stating "host computer 1B must accept and deliver

commands and data in which the differences of communication protocols for the SCSI bus 21 and Ethernet are considered.” See, Oeda, col. 9, lines 47-60 (describing replacing the SCSI bus of FIGURE 5 with a network such as Ethernet). Further in conjunction with FIGURE 6, Oeda describes that while this embodiment allows the storage device to be shared among hosts using different operating systems and network protocols, it still requires the use of high-level network protocols between the host computers and file server (e.g., the network protocols used by UNIX, MS-DOS and the general purpose computer to communicate via Ethernet). See, Oeda, col. 10, lines 22-68.

Again, these Ethernet-based systems of Oeda are precisely the types of systems that the present invention was designed to overcome because they do involve the overhead of high level network protocols typically required by network servers and they do require a translation of a network protocol into SCSI commands at the network server when allowing workstations to make requests to and from storage devices. Thus, similar to Spring, Oeda simply does not teach or suggest the limitation “to allow access from devices connected to the first transport medium to the [remote] storage devices using native low level, block protocols.” (emphasis added).

5. Summary – Allowing Access to Remote Storage Devices Using NLLBP

Neither Oeda or Spring, alone or in combination, teach or suggest allowing access from host devices to remote storage devices using NLLBPs. Spring teaches a SCSI-to-SCSI system in which workstations are connected to a network server via a SCSI bus. Spring does not disclose in this embodiment any distance capable serial transport medium, but simply the limited distance, parallel SCSI transport medium. Consequently, the SCSI-to-SCSI system of Spring does not allow access to “remote” storage devices as recited in Claims 1 and 11. In order to provide the ability to access remote storage devices, Spring introduces Ethernet connectivity (replacing the SCSI bus between the workstations and the server with an Ethernet connection) and higher-level network protocols. Because this Ethernet-to-SCSI embodiment of Spring requires the use of higher-level network protocols it does not “allow access from devices connected to the first transport medium to the [remote] storage devices using native low level, block protocols” as recited in Claims 1 and 11.

Similarly, Oeda teaches a SCSI based system and an Ethernet based system that suffer the same deficiencies as the systems of Spring. In the SCSI based system of Oeda, the storage device is also not indirectly connected to the host computer by at least one serial

transport medium. Consequently, the magnetic storage device is not “remote” from the host computers. The Ethernet based systems of Oeda require the use of higher-level network protocols and, as in Spring, do not “allow access from devices connected to the first transport medium to the [remote] storage devices using native low level, block protocols.”

Thus, in Spring and Oeda, the storage devices are not remote and access to them from the host is not provided using NLLBPs. Rather, the storage devices are connected using limited distance parallel SCSI buses. In order to provide access to a remote storage device, a higher level network protocol must be introduced. That is, in order to allow the storage devices to become remote in Spring and Oeda, access is no longer provided from the workstations to the storage devices using a NLLBP.³ Applicants therefore respectfully submit that Spring and Oeda do not teach or suggest providing “virtual local storage on remote storage devices” and providing access “from a device connected to a first transport medium to the [remote] storage devices using native low level block protocols” as recited in independent Claim 1. As the cited references, alone or in combination, do not teach or suggest this feature of the present invention, Applicants respectfully request allowance of Claim 1. As will be discussed more fully below, these references certainly do not teach or suggest allowing access to remote storage devices in conjunction with mapping and access controls as claimed in the ‘035 Patent.

E. “Map” – Neither Spring nor Oeda Teaches or Suggests Mapping Between Devices Connected to the First Transport Medium and the Storage Devices

1. A Map Includes a Representation of the Devices on the First Transport Medium and the Storage Devices

Claim 1 recites a supervisor unit operable “to map between devices connected to the first transport medium and the storage devices.” Claims 7 and 11 contain similar features. Mapping between devices connected to the first transport medium and storage devices in the present application refers to a mapping between the workstations/host computers and storage devices such that a particular workstation/host computer on the first transport medium is associated with a storage device, storage devices or portion thereof on the second transport

³ Jibbe, a reference directed to a SCSI interface, simply does not address the issue of remote storage devices or allowing access to these remote storage devices using NLLBPs.

medium. As discussed in the '035 Patent Specification, the mapping provides a correlation between devices on the first data transport medium and the storage devices through one or more steps. See, '035 Patent, col. 2, lines 9 – 12, col. 2, lines 20-21, and col. 8, line 61 – col. 9, line 5. In addition, the Federal District Court in the Chaparral and Pathlight Litigations defined the term “map” in its Markman Order as follows: “to create a path from a device on one side of the storage router to a device on the other side of the router, i.e., from a Fibre Channel device to a SCSI device (or vice-versa). A map contains a representation of devices on each side of the storage router, so that when a device on one side of the storage router wants to communicate to a device on the other side of the storage router, the storage router can connect the devices.” See, Markman Order, Exhibit C, page 12 (emphasis added). Thus, the mapping of the '035 Patent associates the host device(s) on the first transport medium with storage devices on the second transport medium to create a path between the host and the remote storage device (or portion thereof). For example, the map can include mapping a host workstation identifier (e.g., address or other identifier) and a virtual representation of a storage device (e.g., a virtual LUN), and potentially even further from the virtual representation of the storage device to a physical representation of the storage device (e.g., a physical LUN).

2. Neither Spring nor Oeda Teaches or Suggests a Map

As an initial matter, Examiner Fleming recognizes that Spring does not map between devices connected to the first transport medium and the storage devices as recited in Claim 1 (and likewise does not point to any place in Jibbe that teaches or suggests such a mapping). See, May 24 Office Action, page 7 (Spring “does not set forth a mapping between the workstations and the storage devices”). Instead, Examiner Fleming attempts to rely on Oeda to show mapping. See, May 24 Office Action, page 7 (“a mapping between workstations (in the form of HOSTs) and the assigned partitions (41-43) is clearly shown”). Oeda, however, does not teach mapping as recited in the '035 Patent because there is no “map” that contains a representation of a device on one side of the storage router and a representation of a storage device on the other side of the storage router so as to create a path to connect the device to the storage device (e.g., to connect the fibre channel host device to a SCSI storage device).

There is no map in Oeda that includes a representation of devices on one side of the disk controller and storage devices on the other side. Such a map is not necessary or used in Oeda, at least in part, because the Hosts are responsible for knowing which target SCSI IDs they can request and the disk controller processes target SCSI IDs without regard to the host

that asserts the ID. Oeda discloses a host-based methodology to associate hosts with a storage partition and does not disclose a “map between devices connected to the first transport medium and the storage devices.” See Oeda, Col. 8, lines 9-13 (host computers are set by the operating system). In Oeda, SCSI IDs for target devices are processed by a SCSI control large-scale integrated circuit (“LSI”) as described in conjunction with FIGURE 7. The LSI contains n comparators and ID registers, with each register containing a SCSI ID for a target device. See Oeda, col. 5, lines 44-48. When a host computer requests a particular target, it does so in the “selection phase” by marking “true” the data line among the eight data lines of the SCSI bus which correspond to the SCSI ID number of the target. See *id.* at col. 5, lines 14-22. Each comparator compares the ID number asserted during the selection phase (e.g., the ID of the desired target) with the ID in the respective register and, if a match is made, generates an ID coincidence signal. See *id.* at col. 5, lines 48-51. Using the example of FIGURE 7, if a host asserts ID 1 on the SCSI bus, comparator 74 will compare the asserted ID to the contents of register 71, comparator 75 will compare the asserted ID to the contents of register 72 and comparator 76 will compare the asserted ID to the contents of register 73. Because the asserted ID matches the contents of register 71, comparator 74 will generate an ID coincidence signal, indicating that the host is requesting SCSI ID 1. The CPU will then process the subsequent commands and data to read data from or write data to the appropriate partition associated with SCSI ID 1 (e.g., partition 41). See, Oeda, col. 5, line 64 through col. 6, line 13. This process is done without regard to the host that actually asserted the SCSI ID 1 in the selection phase. Thus, whenever LSI receives SCSI ID 1 in the selection phase, it processes the corresponding command to read from or write to the appropriate partition regardless of the host device that asserted SCSI ID 1.

The Examiner cites Oeda at Column 7 lines 53-Column 8, line 30 for the proposition that Oeda shows a “map”, however, this reliance on Oeda is misplaced. In a multi-host environment, such as that depicted in FIGURE 4 of Oeda (shown above), each host is set beforehand by its operating system to only request specific SCSI ID’s. See Oeda, col. 8, lines 9-31. Put another way, the operating system sets each host to limit the target SCSI IDs that host can select during the SCSI selection phase. In the example of Oeda, Host 1A is configured by the operating system to request only SCSI ID 1 and SCSI ID 3 and Host 1B is configured by the operating system to request only SCSI ID 2 and SCSI ID 3. See Oeda, col. 7, lines 57-65. Oeda states that it is the operating system of the computer system that sets the host computers beforehand. See Oeda, col. 8, lines 9-13. After the OS sets the host computer

selection configuration, when a particular host selects a particular target ID, for example target ID 1, the LSI of the disk controller identifies the appropriate partition (e.g., partition 41) as described in conjunction with the selection logic of FIGURE 7. Due to Oeda's method for using the operating system to set hosts, the disk controller does not have to (and does not) map host IDs to target SCSI IDs because only hosts configured to request target ID 1, will request ID 1 in the selection phase. Indeed, Oeda fully admits that it does not need or use such a map, stating "when disk controller 5 performs the exclusive control between an access from the host computer 1A and an access from the host computer 1B, it need not consider the difference of the device ID's (here SCSI ID's=7,6) *of the respective host computers 1A and 1B*, but it may merely judge pertinent ones of the device ID's (SCSI ID's=1, 2 and 3) of the respective partitions 41, 42, 43 selected by the host computer 1A and 1B." Oeda, col. 8, lines 20-30 (emphasis added).

Thus, in the Oeda host-based system, the *hosts* know which target SCSI IDs to request and therefore there is no need for a map at the disk controller that controls whether a particular host is mapped to (and can therefore access) a particular storage device (or portion of a storage device). In Oeda each host knows the storage device SCSI IDs it is permitted to access and makes requests only to those storage device IDs. When the disk controller receives a target SCSI ID from a host it directs commands and data to the partition associated with that requested target SCSI ID without regard to the host that made the request. In other words, the disk controller in Oeda does not consult any map to determine whether the host should be connected to the requested target SCSI ID; rather, if the disk controller of Oeda receives a request, it simply forwards it to the appropriate SCSI ID. There is simply no teaching or suggestion in Oeda that disk controller 5, or any other device in Oeda, maintain a "map" that contains a representation of host devices on one side of the disk controller and representations of storage devices on the other side of the disk controller as recited in the claims of the '035 Patent.

Thus, while Oeda does touch on the concept of setting host computer configuration by the operating system (*see* Oeda, col. 8, lines 9-13), it does not teach or suggest doing any form of "mapping" as claimed in the '035 Patent. For example, setting the host configuration to define which target SCSI IDs a host may request can be done by setting registers in the host's host bus adapter ("HBA"). This methodology entails setting flags in registers of the host HBA indicating which SCSI bus lines the host can or cannot set as true. Thus, each host would simply have a listing or set of flags that indicate which target SCSI IDs are available to that

host, but not a map as recited in the '035 Patent that represents that host device itself or the storage devices (i.e., Host 1A does not map itself to storage devices, but simply contains a list or set of register settings indicating that the HBA can only assert true on the bus lines for target SCSI ID 1 and SCSI ID 3). Neither the disk controller nor the individual hosts in Oeda are operable to map between devices on the first transport medium and storage devices. Thus, the host-based configuration method discussed by Oeda does not teach or suggest a map as recited in the '035 Patent.

Furthermore, the mapping recited in the '035 Patent is between host devices connected to the first transport medium and the storage devices that are remote from the host devices. As discussed above, Oeda achieves remoteness through the introduction of Ethernet as discussed in conjunction with FIGURE 6 without the use of NLLBPs. In the Ethernet based system of Oeda, portions of storage are assigned IP addresses based on the operating system/network protocol that is allowed access that IP address and *not* the specific hosts that can access the storage. See, Oeda, col. 10, lines 14-22. Thus, for example, in FIGURE 6 of Oeda, partition 213 is assigned IP address 5002, which is accessible by MS-DOS based computers (i.e., any host computer that runs MS-DOS). In contrast to the invention claimed in the '035 Patent, there is no map between hosts devices and storage devices as the partitions of Oeda's Ethernet system are simply "held in correspondence with OS's and network protocols." See, Oeda, col. 10, lines 24-27. Once again, the Oeda system controller (network file server 19 in FIGURE 6) does not contain a map with representations of particular host computers associated with particular storage partitions, but rather Oeda simply reviews the incoming request to a partition, sees that the incoming request uses a network protocol compatible with the IP address, and allows the request to go to the storage partition without regard to which host sent the request. This is not, and Oeda therefore does not teach or suggest, a map containing a representation of the host devices associated with a representation of the remote storage devices as recited in the claims of the '035 Patent.

F. "Access Controls" – Neither Spring nor Oeda Teaches or Suggests Implementing Access Controls

1. Implementing Access Controls

Claim 1 recites a supervisor unit operable "to implement access controls for storage space on the storage devices and . . . to allow access from devices connected to the first

transport medium to the storage devices using native low level, block protocols.” To implement access controls requires more than simply allowing a host to have access to a storage device. Implementing access controls is a security measure designed to prevent unauthorized access from workstations to particular storage devices or subsets of storage as claimed and described in the ‘035 Patent. When access controls are implemented, particular workstations may be permitted or denied access to particular storage devices or subsets of storage devices. See, e.g., FIGURE 3 of the ‘035 Patent and Graphic 5 above. The storage router uses access controls and routing “such that each workstation has controlled access to only the specified partition of [a storage device] which forms virtual local storage for the workstation. This access control allows security control of the specified data partitions.” See, ‘035 Patent, col. 4, lines 29-34. Further, according to the Markman Order, to “implement access controls” for storage space on the storage devices means to provide “controls which limit a computer’s access to a specific subset of storage devices or sections of a single storage device.” See, Markman Order, Exhibit C, page 6.

The access controls of the ‘035 Patent depend on the map discussed above to control access of devices on a first transport medium (e.g., workstations) to storage devices such that requests from devices connected to the first transport medium are directed to assigned virtual local storage on the storage devices. In other words, the storage to which each workstation is permitted access is controlled through the use of the map. See, ‘035 Patent, col. 4, lines 13-16 (“storage allocated to each . . . workstation 58 through the use of mapping tables or other mapping techniques”). Thus, “the router can . . . map, for each initiator, what storage access is available and what partition is being addressed by a particular request. In this manner, the storage space provided by [storage devices] can be allocated to [devices connected to the first transport medium]” See ‘035 Patent, col. 8, lines 67 – col. 9, line 5.

The access controls of Claim 1 thus permit or deny access from particular host devices connected to the first data transport medium to particular storage devices (or subsets thereof) according to a map that associates the host devices with the remote storage devices. The access controls are part of the configuration for routing commands according to the map from a device connected to the first transport medium to *defined* storage location(s) using NLLBPs (i.e., without requiring the overhead of high level protocols typically required by network servers). The access controls of the present invention thus limit access by workstations to storage devices or subsets of storage devices by allocating storage according to the map.

2. Spring Does Not Implement Access Controls

Regarding Spring, Examiner Fleming stated:

Implementing of access controls is clearly described throughout the disclosure, especially noting that each USER has access to a large number of removable disc drives (see page 7, lines 18-27), thereby teaching the implementation of *some sort of access controls*, with the storage router (server 20) determining if the requested drive is available, and if so, granting access to the requesting workstation (see page 8, lines 10-17). Thus the access is ultimately controlled and allowed by the storage router (server 20). See, May 24 Office Action, page 6.

The passage of Spring cited by Examiner Fleming, namely page 8, lines 10-17, describes a conventional mechanism by which a server coordinates host access to SCSI drives, however this conventional mechanism is accomplished without access controls as defined in the '035 Patent as the coordination of host access described in Spring does not assign particular storage devices or portions thereof to particular workstations (or other device on the first transport medium). This conventional mechanism is not designed to limit any particular host from accessing any particular storage device, but rather to coordinate access to storage between hosts so as to avoid contention between hosts for the same storage. In the conventional mechanism described in Spring, when a workstation requests a logical disk drive, the server determines if the requested logical disk drive is available and if the logical disk drive is available, allows the workstation to access the logical disk drive. Under this scheme, any workstation can access the logical disk drive so long as the drive is available. In other words, Spring does not describe any mechanism that limits host access based on the ID of the host or which particular storage device the host wishes to access; rather, Spring simply uses a conventional SCSI mechanism to coordinate access based on storage device availability. There is simply no teaching or suggestion in Spring that the availability of the logical drive depends on the workstation requesting the drive and whether that particular workstation has been associated with that drive according to some mapping technique. In Spring, there is no map between the workstations of Spring and the emulated SCSI removable drives (as discussed above) that implements access controls to limit a particular workstations ability to access particular emulated SCSI removable drives.

This lack of access controls is demonstrated by Spring's utilization of aspects of removable SCSI drives to coordinate operations between workstations and the fixed SCSI disks. As described above, server 20 in Spring presents large fixed disk drives as multiple, smaller SCSI removable disks. When a workstation wishes to access one of the emulated SCSI removable disks, the workstation will request the logical drive using conventional SCSI command. See, Spring, page 8, lines 4-8. The server will determine if the logical disk drive is available and, if so, will return data to the workstation regarding the logical disk drive including the fact that the logical drive is removable. See, Spring, page 8, lines 10-17. The workstation can then transfer data to the logical disk. See, Spring, page 9, lines 1-3. Once the data transfer is complete, the workstation will issue a SCSI DISMOUNT command to the emulated SCSI removable disk drive. See, Spring, page 10, lines 17-20. Server 20 "acts upon the dismount command by *releasing the logical drive such that it can be accessed by other workstations.*" See, Spring, page 10, lines 24-25 (emphasis added). Thus, Spring is utilizing mechanisms to coordinate access between hosts and storage devices to make sure the storage devices is available.

However, in contrast to the invention of the '035 Patent, this methodology described in Spring does not limit access of particular workstations to specific assigned subsets of storage devices or portions thereof. Rather, any workstation can access any logical removable drive so long as that logical removable drive is not busy (i.e., is available). The use of the DISMOUNT command is to facilitate the coordination of operations of the multiple workstations that all have access to the same portions of the fixed disk drives, and *does not* prevent the access of particular workstations to specific portions of the fixed disk drives. There is simply no mechanism in Spring that prevents particular hosts from accessing particular storage. Spring thus teaches a system that *coordinates* access by multiple workstations to shared disk drives, not a system that permits or denies access by particular workstations to shared disk drives (i.e., Spring does not "limit a computer's access to specific subset of storage devices or sections of a single storage device"). Applicants respectfully submit that Spring as cited by Examiner Fleming does not teach access controls as defined by the '035 Patent. Accordingly, Applicants respectfully request allowance of Claims 1, 7 and 11 and the respective dependent Claims.

Moreover, the Ethernet based system of Spring does not teach or suggest providing access controls for storage devices that are accessed by host computers using a NLLBP. As discussed above, the Ethernet based system of Spring relies on higher level protocols to achieve remote storage. In fact, Spring provides no discussion as to how to implement access

controls in its Ethernet methodology (e.g., there is no discussion how emulating removable SCSI drives are presented over Ethernet to a host or how the DISMOUNT command is processed over Ethernet). Indeed, while there are no access controls as defined by the '035 Patent disclosed in Spring's SCSI-to-SCSI implementation, there is no discussion of any mechanism to limit access for the barely mentioned Ethernet based system of Spring. Thus, Spring fails to teach or suggest implementing access controls from remote storage devices that are accessed by a host computer using an NLLBP. Accordingly, Applicants respectfully request allowance of Claims 1 and 11.

3. Oeda Does Not Teach or Suggest Access Controls

Claim 1 (and Claim 10) of the '035 Patent recites "a supervisor unit . . . operable to . . . implement access controls for storage space on the storage devices." Similarly, Claim 7 recites a storage router "to implement access controls for storage space on the storage devices." The supervisor unit of Claim 1 and storage router of Claim 7 are each clearly configured to connect between the data transport medium to which the host devices are connected and the data transport medium of the storage devices are connected to provide for centralized management of access controls, thus allowing the ability to centrally control and administer storage space. See, '035 Patent, col. 2, lines 33-38. Claim 11 further recites together "mapping between devices connected to the first transport medium and implementing access controls for storage space on the storage devices." The mapping and implementing access controls, as discussed above, are tied together as access controls are implemented to "cause certain requests from FC Initiators to be directed to assigned virtual local storage." See, '035 Patent, col. 8, lines 61-64. Again, access controls are performed by a device (supervisor unit/storage router) where mapping between devices on the first transport medium and the storage devices occurs, allowing for central control of storage space.

The SCSI-to-SCSI implementation of FIGURE 4 of Oeda does not provide for this type of access controls. In other words, there is no device in the system of FIGURE 4 of Oeda that manages storage space for hosts using mapping. Instead, in Oeda each host computer is set by the operating system to be assigned to a particular partition. Thus each host in Oeda contains flags, or other indications set beforehand, of the target SCSI bus lines corresponding to target SCSI IDs it can request so that each host can only request those target IDs (e.g., Host 1A is configured so that it can only send requests to SCSI ID 1 and SCSI ID 3). See, Oeda,

col. 8, lines 9-14. Because Host 1A is configured not to request SCSI ID 2, it will not erroneously request partition 42. See, Oeda, col. 8, lines 14-16. The control of the SCSI IDs and therefore corresponding partitions that hosts can request thus occurs at *each of the hosts* and not at a supervisor unit/storage router or mapping as in the Claims 1, 7 and 11 of the '035 Patent.

In contrast to Oeda, Claims 1 and 7 of the '035 Patent require a supervisor unit or storage router that "implements access controls". In contrast, Oeda, has no supervisor unit or storage router connected between the hosts and remote storage devices that implements access controls. The disk controller 5 of Oeda as shown with reference to LSI 6 of FIGURE 7, simply forwards requests for a particular SCSI ID to the appropriate target. The disk controller does not process the host IDs, or perform any other mechanism to limit access of any particular host to any particular storage. The disk controller merely processes "pertinent ones of the device ID's (SCSI ID's=1, 2 and 3) of the respective partitions 41, 42, 43 selected by the host computer 1A and 1B." Oeda, col. 8, lines 20-30. Disk controller 5 is completely agnostic as to which host asserts a specific target ID as it is assumed in Oeda available target IDs are set beforehand at the hosts. Thus, disk controller 5 does not act as a storage router or supervisor unit that implements access controls for the storage space to limit a host's access to portions of the storage space.

Similarly, Oeda does not have a "mapping between devices connected to the first transport medium and the storage devices and implementing access control for storage space" as recited in Claim 11. In the '035 Patent, the implementation of access controls is accomplished in conjunction with the map which maps the host devices to the remote storage devices. As discussed above, neither the disk controller 5 of Oeda nor any other component of Oeda utilize a map that maps between devices connected to the first transport medium and the storage devices. There is, consequently, no component of Oeda that uses a map to provide for management of storage space by "mapping between devices connected to the first transport medium and the storage devices and implementing access controls for storage space." In other words, there is no teaching in Oeda of implementing access controls by providing a mapping of what storage access is available and what partition is being addressed by a particular request such that "the storage space provided by [storage devices] can be allocated to [devices connected to the first transport medium]" See '035 Patent, col. 8, lines 67 – col. 9, line 5.

In Oeda, because the hosts are set to know which SCSI IDs they can request and any host (or other device) that asserts a particular SCSI target ID is granted access to the corresponding partition, there is simply no mechanism (e.g., supervisor unit, storage router or mapping) that limits each particular hosts' access to the storage device or particular partitions of the storage device. Therefore, Applicants respectfully request allowance of Claims 1, 7 and 11.

4. The Ethernet Based Configuration of Oeda Does Not Teach or Suggest Any Form of Access Controls For Remote Storage

As discussed previously, the storage devices for which access controls are provided are "remote storage devices" that are remote from the host devices requesting access. The portions of Oeda cited by the Examiner, namely those associated with of FIGURE 4, as allegedly providing access controls are discussed entirely within the context of a local, SCSI-to-SCSI storage implementation. While this host-based mechanism of Oeda is not the claimed access controls mechanism of the '035 Patent (as discussed above), Oeda provides no teaching or suggestion as to how even that host-based mechanism could be implemented for remote storage and, indeed, discards entirely that host-based storage allocation mechanism of FIGURE 4 when moving to the remote storage implementation of FIGURE 6.

As discussed above, Oeda introduces Ethernet to achieve remoteness. As shown in FIGURE 6, portions of storage are assigned IP addresses based on the operating system that can access that IP address, not the specific hosts that can access the storage. See, Oeda, col. 10, lines 14-22. Thus, for example, partition 213 is assigned IP address 5002, which is accessible by MS-DOS based computers. See, Oeda, col. 10, lines 37-39. Any computer that supports MS-DOS can access partition 213. See, Oeda, col. 10, lines 46-54 (explaining how the network file server handles requests to a particular IP address). The network file server does not provide any security to prevent hosts using the same operating system from accessing each other's data but simply forwards requests to a particular IP address to the proper storage.

While Oeda discloses providing remote storage, this is done using a higher level network protocol (not using NLLBP) without any access controls as claimed in the '035 Patent. Any computer using the same operating system and higher level network protocols can access the same partitions of storage. Oeda does not teach or suggest providing access controls for remote storage that is accessed by a host using NLLBP and, consequently, does not remedy

the deficiencies of Spring. Applicants therefore respectfully request allowance of Claims 1 and 11.

G. The Combination of Oeda and Spring Does Not Teach or Suggest the Present Invention

Even assuming *arguendo* that Spring and Oeda can be combined as suggested by Examiner Fleming, these references in combination do not teach or suggest the present invention. If combined in a SCSI-to-SCSI system, the combination of Spring and Oeda fails to teach or suggest mapping and implementing access controls for the storage space or mapping and implementing access controls at a supervisor unit or storage router. For remote storage, both Spring and Oeda teach the use of higher level network protocols and neither teaches mapping between devices connected to the Ethernet transport medium and the remote storage devices or implementing access controls for the storage space on the remote storage devices. Thus, the combination of Spring and Oeda fails to disclose allowing access to remote storage using a NLLBP in conjunction with providing a mapping between devices connected to a first transport medium and remote storage in conjunction with implementing access controls for the remote storage devices.

H. The Jibbe Reference Does Not Address the Deficiencies of Spring and Oeda

Jibbe discloses a SCSI interface that is used to connect a host computer to a SCSI disk array. The interface of Jibbe allows a host computer to transfer operations to a number of disk drives configured as a RAID 1, 2, 3, 4, or 5 disk array. See, Jibbe, Abstract. There is simply no teaching or suggestion in Jibbe that the disk array should be attached by anything other than a local SCSI bus and consequently does not teach or suggest remote storage devices. Moreover, Examiner Fleming did not cite the Jibbe reference as showing, nor does the Jibbe reference appear to show, mapping between devices connected to the first transport medium and the storage devices, implementing access controls or allowing access from hosts to storage devices using NLLBP.

I. Summary: There is No *Prima Facie* Case of Obviousness

The '035 Patent provides a system and method which allows a host computer to access remote storage devices using an NLLBP, while mapping between the host computers and

remote storage devices (or portions thereof) and implementing access controls for storage space on the remote storage devices. Spring and Oeda teach either local SCSI-to-SCSI systems that do not provide remote storage or Ethernet-to-SCSI systems that rely on higher level protocols. While the Examiner has attempted to point to access controls in Spring and access controls and mapping in Oeda, these references show neither access controls nor mapping. Moreover, the portions in Spring and Oeda relied on for mapping and access controls (which do not, in fact, show mapping and access controls as discussed above) only apply to the SCSI-to-SCSI local storage implementations and do not apply to the Ethernet-to-SCSI implementations of these references that allow for remote storage. Consequently, Spring and Oeda do not show a system or method that provides access from host computers to remote storage using NLLBP, while applying access controls that limit a host computer's access to specified portions of the remote storage, nor do they teach mapping between the host computers and the remote storage devices.

None of the additional art cited by the Examiner remedy the deficiencies of Oeda and Spring. Jibbe does not address the issue of remote storage, nor does Jibbe discuss access controls or mapping.

Applicants respectfully submit that the Examiner has failed to establish a *prima facie* case of obviousness for Claims 1-14 as the prior art references do not disclose, teach or suggest all of the claim limitations. Specifically, the prior art cited by Examiner Fleming does not teach or suggest: i) providing virtual local storage on remote storage devices and allowing access from devices connected to the first transport medium to the remote storage devices using a NLLBP; in conjunction with ii) mapping between devices on the first transport medium and the storage devices; in conjunction with iii) implementing access controls. While Examiner Fleming provided a thorough analysis of Spring and Oeda, these references simply fail to teach the claimed limitations. Furthermore, Jibbe does not make up for the deficiencies of Spring and Oeda. Accordingly, Applicants respectfully request allowance of Claims 1-14.

II. Conclusion

Applicants appreciate Examiner Fleming's consideration of the previous response and Examiner's interview when drafting the May 24 Office Action. Moreover, Applicants further appreciate Examiner Fleming's careful and detailed review of all of the submitted prior art and the issuance of a non-final office action. Applicants respectfully submit, however, that Claims

Attorney Docket No.
CROSS1123-17 and
CROSS1123-19

Customer ID: 44654
90/007,125
90/007,317

41

1-14 are distinguishable from Spring, Oeda and Jibbe for the reasons stated herein. Therefore, Applicants respectfully request allowance of all claims subject to reexamination.

This Reply was served via First Class Mail on July 22, 2005 to:

Larry E. Severin
Wang, Hartmann & Gibbs,
PC
1301 Dove Street, #1050
Newport Beach, CA 92660

William A. Blake
Jones, Tullar & Cooper, PC
P.O. Box 2226 Eads Station
Alexandria, VA

The Director of the U.S. Patent and Trademark Office is hereby authorized to charge any fees or credit any overpayments to Deposit Account No. 50-3183 of Sprinkle IP Law Group.

Respectfully submitted,

Sprinkle IP Law Group
Attorneys for Applicant

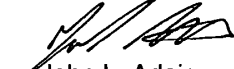

John L. Adair
Reg. No. 48,828

Date: July 22, 2005
1301 W. 25th Street, Suite 408
Austin, TX 78705
Tel. (512) 637-9223
Fax. (512) 371-9088

**This Page is Inserted by IFW Indexing and Scanning
Operations and is not part of the Official Record**

BEST AVAILABLE IMAGES

Defective images within this document are accurate representations of the original documents submitted by the applicant.

Defects in the images include but are not limited to the items checked:

- BLACK BORDERS
- IMAGE CUT OFF AT TOP, BOTTOM OR SIDES
- FADED TEXT OR DRAWING
- BLURRED OR ILLEGIBLE TEXT OR DRAWING
- SKEWED/SLANTED IMAGES
- COLOR OR BLACK AND WHITE PHOTOGRAPHS
- GRAY SCALE DOCUMENTS
- LINES OR MARKS ON ORIGINAL DOCUMENT
- REFERENCE(S) OR EXHIBIT(S) SUBMITTED ARE POOR QUALITY
- OTHER: _____

IMAGES ARE BEST AVAILABLE COPY.

As rescanning these documents will not correct the image problems checked, please do not report these problems to the IFW Image Problem Mailbox.

ARTIFACT SHEET

Enter artifact number below. Artifact number is application number + artifact type code (see list below) + sequential letter (A, B, C ...). The first artifact folder for an artifact type receives the letter A, the second B, etc..

Examples: 59123456PA, 59123456PB, 59123456ZA, 59123456ZB

(901007, 317CA)

Indicate quantity of a single type of artifact received but not scanned. Create individual artifact folder/box and artifact number for each Artifact Type.

- CD(s) containing:
- computer program listing Artifact Type Code: P
 - Doc Code: Computer
 - pages of specification
 - and/or sequence listing
 - and/or table
 - Doc Code: Artifact
 - content unspecified or combined Artifact Type Code: S
 - Doc Code: Artifact
 - Artifact Type Code: U

- Stapled Set(s) Color Documents or B/W Photographs
- Doc Code: Artifact Artifact Type Code: C

- Microfilm(s)
- Doc Code: Artifact Artifact Type Code: F

- Video tape(s)
- Doc Code: Artifact Artifact Type Code: V

- Model(s)
- Doc Code: Artifact Artifact Type Code: M

- Bound Document(s)
- Doc Code: Artifact Artifact Type Code: B

- Confidential Information Disclosure Statement or Other Documents marked Proprietary, Trade Secrets, Subject to Protective Order, Material Submitted under MPEP 724.02, etc.
- Doc Code: Artifact Artifact Type Code X

- Other, description: _____
- Doc Code: Artifact Artifact Type Code: Z

March 8, 2004

EXHIBIT B

IN THE UNITED STATES DISTRICT COURT
FOR THE WESTERN DISTRICT OF TEXAS
AUSTIN DIVISION

FILED
AUSTIN DIVISION
2005 JAN 21 AM 11:28
WESTERN DISTRICT OF TEXAS
U.S. CLERK'S OFFICE
BY: [Signature] DEPUTY

CROSSROAD SYSTEMS (TEXAS), INC.,
Plaintiff,

-vs-

DOT HILL SYSTEMS CORPORATION,
Defendant.

Case No. A-03-CA-754-SS'

REPORT AND RECOMMENDATION OF THE SPECIAL MASTER
REGARDING UNITED STATES PATENT NOS. 5,941,972 and 6,425,035 B2

Attached hereto is the Special Master's Report and Recommendation to United States District Judge Sam Sparks regarding the construction of claims in United States Patent Nos. 5,941,972 ("the '972 patent") and 6,425,035 B2 ("the '035 patent").

The Special Master notes that during the course of the pre-hearing and post-hearing briefing as well as the *Markman* hearing itself, the parties reached agreement on certain terms initially identified as being in dispute. For instance, the parties' stipulated definition of the claim term "native low level, block protocol," which is the same in both patents, was incorporated into their Stipulated Definitions of Claim Terms [#131], filed with the Court on August 31, 2004. Also, although Crossroads initially identified the term "remote storage devices" in the '035 patent as one of the terms requiring the Court's construction, it has apparently abandoned that position since the parties' dispute over the meaning of "remote storage devices" may be resolved by the Court's construction of the word "remote" without the need for a separate construction of the entire phrase.

Additionally, in its post-hearing briefing, Crossroads stipulated to Dot Hill's definition of the term "allow access" in both patents based on the representations of Dot Hill's counsel at the hearing and in Dot Hill's briefing that the portion of Crossroads' proposed definition which was excluded by Dot Hill's definition—"preventing unauthorized communication"—is part of the definition of the phrase, "implementing access controls," which also appears in the patents. See

245

Crossroads's Post-Hr'g *Markman* Br. at 8; Tr. of *Markman* Hr'g at 119:2-19; Dot Hill's Post-*Markman* Hr'g Claim Construction Br. at 22.

Proposed constructions for the remaining disputed terms are attached hereto. The parties may file written objections to the recommendations made in this report within ten (10) days from the date of their receipt of it pursuant to the Court's Order of February 23, 2004.

SIGNED this the 19th day of January 2005.

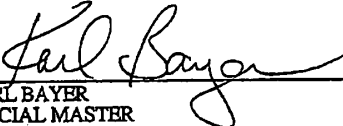
KARL BAYER
SPECIAL MASTER

Actual Claims Language	Crossroads' Proposed Construction	Crossroads' Evidence	Dot Hill's Proposed Construction	Dot Hill's Evidence	Special Master's Construction
<p>A storage router for providing virtual local storage on remote storage devices to devices, comprising: a buffer providing memory work space for the storage router; a first controller operable to connect to and interface with a first transport medium;</p>	<p>Remote: "Indirectly connected through at least one serial network transport medium that encapsulates the native low-level block protocol."</p>	<p>Remote: Intrinsic: '035 patent: col. 1, ll. 23-36; col. 2, ll. 1-34; col. 5, ll. 46-48; col. 5, ll. 52-57; col. 6, ll. 19-31; col. 9, ll. 26-31. Extrinsic: Tr. 102:14-20; Rhyme Cross, Tr. 159:17-18; Rhyme Cross, Tr. 161:7-8; Rhyme Cross, Tr. 174:14-24; Tr. 180:5-14; Mr. Erwine's Notes, Shelton Decl. ISO Crossroads' Reply, Ex. 4.</p>	<p>Remote: Indirectly connected and capable of physical separation. NOTE: This is the definition of <i>remote</i>, but since this phrase appears only in the preamble to explain the context in which the storage router is used, it is not a limitation of this claim.</p>	<p>computer through a network)." (DHS Brief Ex. 10) Remote: Intrinsic: '035 Patent: Col. 1, lines 39-42 using the term "remote" to refer to storage which is not "local," and defining "local" as "a disk drive, tape drive, CD-ROM drive or other storage device contained within, or locally connected to the workstation." Col. 1, lines 63-67, describing storage capacity which is not local as "remote." Col. 2, line 32 "significantly remote"</p>	<p>Remote: Indirectly connected through at least one serial network transport medium.</p>
				<p>Extrinsic: <i>Webopedia</i> definition of "remote" (Last modified</p>	

Special Master's Proposed Construction of Disputed Terms			
Actual Claims Language	Crossroads' Proposed Construction	Crossroads' Evidence	Dot Hill's Proposed Construction
			<p>Dot Hill's Evidence</p> <p>September 1, 1996) as "In networks, remote refers to files, devices, and other resources that are not connected directly to your workstation. Resources at your workstation are considered local" (DHS Brief Ex. 6)</p> <p><i>Webopedia</i> definition of "local" (Last modified September 1, 1996) as "In networks, local refers to files, devices, and other resources at your workstation. Resources located at other nodes on the network are remote." (DHS Brief Ex. 6)</p> <p>Deposition of inventor Hoese, pages 143, 146, 147, 154-155 confirming that "remote" is not a function of distance by stating "It appears to be that the intent was to describe the storage as</p>
			<p>Special Master's Construction</p>

Actual Claims Language	Crossroads' Proposed Construction	Special Master's Proposed Construction of Disputed Terms	Dot Hill's Evidence	Special Master's Construction
			<p>not being directly connected as local storage would be, but to be connected remotely, as in across a network or other means." (DHS Brief Ex. 14)</p> <p>Deposition of inventor Russell pages 104-105 confirming that "remote" is not a function of distance by stating "And it might be right next to me or it could be, you know, across the country, but that would allow me to get at that remote storage." (DHS Brief Ex. 15)</p> <p>Declaration of Rhyme, paragraph 19, stating that "[t]he meaning of 'remote' in general and in the specific context of the Crossroads patents has nothing to do with the physical distance between a workstation</p>	

Special Master's Proposed Construction of Disputed Terms			
Actual Claims Language	Crossroads' Proposed Construction	Crossroads' Evidence	Dot Hill's Proposed Construction
			<p>Dot Hill's Evidence</p> <p>Special Master's Construction</p>
			<p>and a storage device, but rather has to do with the topological nature of the interconnection between those devices." (DHS Responsive Brief Ex. 18)</p> <p>Declaration of Rhyme, paragraph 27, stating that "[t]he common meaning of 'remote' is the opposite of 'local,' and does not carry a distance characteristic." (DHS Responsive Brief Ex. 18)</p> <p>Declaration of Hodges in Support of Crossroads' Opening Markman Brief (7/27/04), paragraph 9, stating that "The term 'local storage' typically refers to storage devices which are directly connected to the computer (as opposed to storage devices connected to a computer through a network). Local storage also</p>

Special Master's Proposed Construction of Disputed Terms			
Actual Claims Language	Crossroads' Proposed Construction	Crossroads' Evidence	Dot Hill's Proposed Construction
a second controller operable to connect to and interface with a second transport medium; and a supervisor unit coupled to the first controller, the second controller and the buffer, the supervisor unit operable to map between devices connected to the first transport medium and the storage devices,	Supervisor Unit: "A computer processing device programmed to process data in a buffer in order to map between device connected to a first transport medium and devices connected to a second transport medium which implements access controls."	Supervisor Unit: Intrinsic: '035 patent: col. 6, ll. 3-10; col. 9, ll. 22-31. Extrinsic: Hodges Direct, Tr. 36:3-37:9.	Supervisor Unit: A microprocessor programmed to process data in a buffer in order to map between devices connected to the first transport medium and storage devices and which implements access controls.
		Supervisor Unit: Intrinsic: '035 Patent: Col. 5, lines 12-17, describing a Supervisor Unit that "comprises a microprocessor ..." Col. 1, lines 37-39 and col. 4, lines 39-40 equating a "computing device" with workstations.	Supervisor Unit: A device comprising at least: (1) a microprocessor, incorporating independent data and program memory spaces; and (2) associated logic required to implement a stand alone processing system and programmed to process data in a buffer in order to map between devices connected to a first transport medium and devices connected to a second transport medium and which implements access controls.
		typically refers to storage devices which are located a very short distance from the computer, i.e. a few feet" (Crossroads' Brief) Markman hearing testimony of Rhyne at 15:3-15, showing that a definition of "remote" could be simply "indirectly connected." (Hearing Transcript)	typically refers to storage devices which are located a very short distance from the computer, i.e. a few feet" (Crossroads' Brief) Markman hearing testimony of Rhyne at 15:3-15, showing that a definition of "remote" could be simply "indirectly connected." (Hearing Transcript)
		Compare '035 claims	

EXHIBIT C

UNITED STATES DISTRICT COURT
WESTERN DISTRICT OF TEXAS
AUSTIN DIVISION

FILED

JUL 27 2000

U.S. DISTRICT COURT
BY CLERK'S OFFICE
DEPUTY

CROSSROADS SYSTEMS, (TEXAS), INC. §

vs. §

CHAPARRAL NETWORK §
STORAGE, INC. §

NO. A 00 CA 217 SS

CROSSROADS SYSTEMS, (TEXAS), INC. §

vs. §

PATHLIGHT TECHNOLOGY, INC. §

NO. A 00 CA 248 SS

ORDER

BE IT REMEMBERED that on the 25th day of July 2000 the Court, in accordance with *Marioman v. Westview Instruments, Inc.*, 52 F.3d 967 (Fed. Cir. 1995), *aff'd*, 116 S. Ct. 1384 (1996), held a hearing at which the parties appeared by representation of counsel and made oral arguments on their proposed claims construction. At the hearing, the parties presented a Joint Stipulation of Claim Construction, indicating that the parties have agreed upon the definitions for seventeen terms and/or phrases in U.S. Patent No. 5,941,972 ("the '972 patent"), and that only ten terms and/or phrases in the '972 patent remain in dispute. After considering the briefs, the case file as a whole, and the applicable law, the Court enters the following opinion and order.

I Standard for Claims Construction

The construction of claims, or the definition of the terms used in the claims, is a matter of law for the Court. When adopting a claim construction, the Court should first consider the intrinsic evidence, which includes the claims, the specification, and the prosecution history. *See Vitronics*

27

A 00473

RECEIVED

FEB 07 2005

OFFICE OF PETITIONS

Corp. v. Conceptoronic, Inc., 90 F.3d 1576, 1582 (Fed. Cir. 1996) (explaining that intrinsic evidence is "the most significant source of the legally operative meaning of disputed claim language"). Not surprisingly, the starting point is always "the words of the claims themselves." *Id.*; see also *Comark Communications, Inc. v. Harris Corp.*, 156 F.3d 1182, 1186 (Fed. Cir. 1998). The words of the claims are generally given their ordinary and customary meaning, unless the patentee intended to use a "special definition of the term clearly stated in the patent specification or file history." *Vitronics*, 90 F.3d at 1582. Thus, the Court must review the specification and file history to determine whether the patentee intended to use any such "special" definitions. See *id.* The specification and file history may also be consulted as general guides for claim interpretation. See *Comark*, 156 F.3d at 1186.

The specification and file history, however, are not substitutes for the plain language of the claims. The specification is not meant to describe the full scope of the patent – it includes only a written description of the invention, sufficient to enable a person skilled in the art to make and use it, as well as the invention's "best mode." See 35 U.S.C. § 112. Thus, the claims may be broader than the specification, and generally should not be confined to the examples of the invention set forth in the specification. See *Comark*, 156 F.3d at 1187 ("Although the specification may aid the court in interpreting the meaning of disputed claim language, particular embodiments and examples appearing in the specification will not generally be read into the claims."). Indeed, the Federal Circuit has repeatedly emphasized that "limitations from the specification are not to be read into the claims." *Id.* at 1186.

In addition to examining the intrinsic evidence the Court may, in its discretion, receive extrinsic evidence regarding the proper construction of the patent's terms. See *Key Pharmaceuticals*

v. Hercon Labs. Corp., 161 F.3d 709, 716 (Fed. Cir. 1998) (“[T]rial courts generally can hear expert testimony for background and education on the technology implicated by the presented claim construction issues, and trial courts have broad discretion in this regard.”). The plaintiff has provided an expert affidavit and the defendant has provided excerpts from several dictionaries as extrinsic evidence concerning the construction of the terms of the ‘972 patent.

II. “implements access controls for storage space on the SCSI storage devices”

This phrase is used in claims 1, 10 and 11 of the ‘972 patent. The parties dispute whether the phrase refers to “access controls” only for certain subsections of a divided SCSI storage device, or whether it also includes limiting access to entire undivided SCSI storage devices. The plaintiff argues the phrase includes both kinds of access controls; the defendants say the phrase refers only to access controls for various subsections within a single divided SCSI storage device. The defendants also argue the plaintiff’s construction is improper because, if adopted, it will result in the ‘972 patent being invalidated by prior art.

The plaintiff proposes the following definition: “provides controls which limit a computer’s access to a specific subset of storage devices or sections of a single storage device.” See Plaintiff’s Brief, at 20. The defendants propose the phrase should be defined as “partitions the storage space on each one of the SCSI storage devices and defines the accessibility of each resulting partition.” See Defendants’ Brief, Ex. 2. The Court agrees with the plaintiff.

The intrinsic evidence of the ‘972 patent shows the plaintiff’s invention is intended to restrict access both to subsections of a SCSI storage device, as well as to entire, undivided SCSI devices. First, the plain language of this phrase refers only to “storage space” and does not limit the space

only to subsections of a divided SCSI storage device. Second, Figure 3 of the '972 patent supports a broad reading of this phrase. Figure 3 shows three SCSI storage devices, two of which are undivided (60 and 64). The third device (62) is divided into four subsections of storage space. From the simple labeling on Figure 3, it is clear that the entire, undivided storage device (64) is meant to be accessed only by a single workstation (computer E). Thus, Figure 3 expressly shows that the plaintiff's invention contemplates using "access controls" for an entire, undivided storage device as well as for the divided subsections within a single storage device.¹ Third, the language of the specification expressly describes limiting access to an entire, undivided SCSI storage device. Specifically, in referring to Figure 3, the specification states "storage device 64 can be allocated as storage for the remaining workstation 58 (workstation E)." See '972 Patent, at 4:20 - 4:21. At the hearing, the defendants' counsel argued that, simply because Figure 3 describes this feature does not mean the feature was intended to be part of the claimed invention. The Court soundly rejects this argument. Figure 3 is meant to be an example of how the plaintiff's claimed invention can be implemented, and the specification clearly describes this figure as illustrating one implementation of the claimed invention. Adopting the defendants' argument would ignore a fundamental principle of claims construction, oft repeated in the defendants' brief and oral arguments, that the specification is "the single best guide to the meaning of a disputed term." See *Vitronics*, 90 F.3d at 1582. Finally, the defendants correctly point out that the specification also refers to the single, undivided storage device (64) as a "partition (i.e., logical storage definition)." See '972 Patent, at 4:44 - 4:47. Rather than compel the defendants' proposed construction, however, this language supports the plaintiff's

¹ Figure 3 also discloses – and the defendants do not dispute – that the plaintiff's invention contemplates limiting access to various subsections of the divided SCSI storage device (62).

argument at the hearing that a discrete unit of storage – whether an entire SCSI storage device or a subsection within that device – can be referred to as a “partition.”²

The defendants also argue that, even if the intrinsic evidence supports the plaintiff’s proposed definition, this definition is nonetheless improper because it would cause the ‘972 patent to read directly upon prior art (and therefore be invalid). It is true that “claims should be read in a way that avoids ensnaring prior art if it is possible to do so.” *Harris Corp. v. IXYS Corp.*, 114 F.3d 1149, 1153 (Fed. Cir. 1997). However, the defendants have not shown that the prior art at issue – the Lui patent – would be “ensnared” by adopting the plaintiff’s definition. Importantly, the Lui patent was part of the prior art expressly considered by the patent examiner before granting the ‘972 patent. The patent examiner apparently did not use the Lui patent to reject a single claim in the ‘972 patent. The patent examiner also did not issue an Office Action requiring the plaintiff to distinguish its invention from the Lui patent on access control (or any other) grounds. Although the Patent Office is not the model of efficiency or thoroughness, its failure to cite the Lui patent as potentially invalidating prior art creates a strong presumption that the Lui patent does not read upon the plaintiff’s claimed invention. In addition, it does not appear to the Court that the Lui patent reads upon the ‘972 claimed invention. While the Lui patent does disclose a system of Fibre Channel computers and SCSI storage devices, *see* Defendants’ Brief, Ex. 6, at 2:53 - 2:65, the similarities end there. The Lui patent concerns an invention of “bypass circuits” used to “prevent the failure of any device” in the system. *See id.*, at Abstract. The invention of the Lui patent is not concerned with the swift transfer of information across a router, and thus does not disclose techniques for mapping,

² The Court expressly notes, however, that it is not defining the term “partition” in this order, as that term is not used in the ‘972 claim language.

implementing access controls, or a memory buffer.³ At the hearing, the defendants' counsel suggested that Figure 2 of the Lui patent discloses the claimed invention of the '972 patent.

However, Figure 2 of the Lui patent is not a part of the Lui invention; rather it is an illustration of a "conventional" network system that the Lui invention allegedly improves upon. *See id.* at 3:66. The Court rejects the defendants' argument that "conventional" network systems also read directly upon the '972 claimed invention. The patent examiner may have let one piece of prior art slip by; he or she would not have missed a "conventional" network system directly applicable to the plaintiff's claimed invention.

In sum, the Court will adopt the plaintiff's proposed definition and construe the phrase "implements access controls" in the claims of the '972 patent to mean "provides controls which limit a computer's access to a specific subset of storage devices or sections of a single storage device."

III. "allocation of subsets of storage space to associated Fibre Channel devices, wherein each subset is only accessible by the associated Fibre Channel device"

The dispute here is essentially the same as in the preceding section. This phrase is used in claims 2, 8 and 12 of the '972 patent. As it did with the "implements access controls . . ." phrase, the plaintiff argues the "allocation . . ." phrase means that specific Fibre Channel devices can be allocated storage space on subsections of a single SCSI storage device and on entire, undivided SCSI storage devices. The defendants stick to their general argument on this issue, and contend the phrase

³ The defendants argue these features are "implicitly" found in the Lui specification and in any event were disclosed in other prior art. *See Defendants' Brief*, at 12 and n.1. The Court is not persuaded that these features are "implicitly" disclosed by the Lui patent, and the other prior art briefly referenced by the defendants makes no mention of combining that prior art with the invention of the Lui patent, or vice-versa.

means storage space can only be allocated on subsections of a single divided SCSI storage device. Both parties agree this storage space, however it is defined, can only be accessed by the specified Fibre Channel device(s).

The plaintiff's proposed definition is "subsets of storage space are allocated to specific Fibre Channel devices." See Plaintiff's Brief, at 26. The defendants say the phrase should be defined to mean "one or more partitions that are only accessible by a single Fibre Channel device." See Defendants' Brief, Ex. 2. For the reasons discussed in the preceding section, the Court adopts the plaintiff's proposed construction.

IV. "supervisor unit"

This term is used in claims 1, 2 and 10 of the '972 patent. The plaintiff contends this term should be defined as "a microprocessor programmed to process data in a buffer in order to map between Fibre Channel devices and SCSI devices and which implements access controls." See Plaintiff's Brief, at 25. The defendants argue the term should be defined as "an Intel 80960RP processor" with several specific features. See Defendants' Brief, Ex. 2.

The defendants argue their construction is mandated by the means-plus-function analysis of § 112(6) of the Patent Act, because the claims of the '972 patent do not adequately describe the "supervisor unit" to be used. See Defendants' Brief, at 15-17. The plaintiff argues that § 112(6) does not apply because the term "means" is not used with the term "supervisor unit" and because the term "supervisor unit" is adequately described by other claim language in the '972 patent. See Plaintiff's *Markman* Exhibits, at 35-39.

Section 112(6) of the Patent Act provides that when a claim refers to the "means for" a

specific act, but fails to adequately describe these means, the means then must be defined by reference to the specification. See 35 U.S.C. § 112(6).⁴ If the claim language at issue does not include the term "means," there is a presumption that the § 112(6) means-plus-function analysis does not apply. See *Al-Site Corp. v. VSI Int'l, Inc.*, 174 F.3d 1308, 1318 (Fed. Cir. 1999) ("[W]hen an element of a claim does not use the term 'means,' treatment as a means-plus-function claim element is generally not appropriate."). To overcome this presumption, the party seeking to apply § 112(6) must show the claim language at issue is purely functional and that other claim language does not adequately describe the disputed term. See *id.* ("[W]hen it is apparent that the element invokes purely functional terms, without the additional recital of specific structure or material for performing that function, the claim element may be a means-plus-function element despite the lack of express means-plus-function language."). From a review of the claim language as a whole, the Court agrees with the plaintiff that the term "supervisor unit" is not purely functional, but refers instead to a device that can perform the tasks specifically listed in the claim language of the '972 patent. Specifically, claims 1, 2 and 10 of the '972 patent describe a "supervisor unit" that can: (1) maintain and map the configuration of networked Fibre Channel and SCSI storage devices; (2) include in this configuration an allocation of specific storage space to specific Fibre Channel devices; (3) implement access controls for the SCSI storage devices; and (4) process data in the storage router's buffer to allow an exchange between the Fibre Channel and SCSI storage devices. See '972 Patent,

⁴ Section 112(6) reads as follows: "An element in a claim for a combination may be expressed as a means or step for performing a specified function without the recital of structure, material, or acts in support thereof, and such claim shall be construed to cover the corresponding structure, material, or acts described in the specification and equivalents thereof." 35 U.S.C. § 112(6).

at Claims 1, 2 and 10. These are the same tasks described in the plaintiff's proposed definition. In addition, the specification expressly defines the "supervisor unit" as "a microprocessor" (a computer chip) and specifically as "a microprocessor for controlling operation of storage router 56 and to handle mapping and security access for requests between Fibre Channel 52 and SCSI bus 54." See *id.* at 5:7 - 5:10. However, neither the specification (nor the claim language) limits the '972 patent to the specific Intel computer chip referenced by the defendants. Although the defendants correctly point out that the Intel 80960 chip is the only computer chip expressly named in the '972 patent and the specification describes many features of this chip, the defendants fail to note that the Intel 80960 chip is listed as only "one implementation" of the claimed invention's microprocessor. See '972 Patent, at 5:63. The defendants are attempting exactly what the Federal Circuit prohibits - to limit the claims to the preferred embodiment and examples of the specification. "This court has cautioned against limiting the claimed invention to preferred embodiments or specific examples in the specification." *Comark*, 156 F.3d at 1186 (quoting *Texas Instruments, Inc. v. United States Int'l Trade Comm'n*, 805 F.2d 1558, 1563 (Fed. Cir. 1988)). The Court will not use an example of "one implementation" in the specification to limit the plain language of the claims. Accordingly, the Court adopts the plaintiff's definition of "supervisor unit" and will construe that term as used in the claims of the '972 patent to mean "a microprocessor programmed to process data in a buffer in order to map between Fibre Channel devices and SCSI devices and which implements access controls."

V. "SCSI storage devices"

This term is used in claims 1, 4, 7, 9-11 and 14 of the '972 patent. The plaintiff argues that this term essentially needs no further definition because the term SCSI is so well-known in the industry, but proposes that the term can be further defined as "any storage device including, for

example, a tape drive, CD-ROM drive, or a hard disk drive that understands the SCSI protocol and can communicate using the SCSI protocol." See Plaintiff's Brief, at 18. The defendants argue the term should be defined as "any storage device that uses a SCSI standard and has a unique BUS:TARGET:LUN address." See Defendants' Brief, Ex. 2.

The Court agrees with the plaintiff. Essentially, the defendants contend their narrow definition should be used because it "comports with '972 specification" and its discussion of SCSI storage devices. See Defendant's Brief, at 14. However, the specification language referred to by the defendants is only one example of how the SCSI storage device addressing scheme "can" be represented. See '972 Patent, at 7:39. Again, the defendants are impermissibly trying to limit the claim language to an example given in the specification. See *Comark*, 156 F.3d at 1186-87. For the sake of extra clarity, the Court will adopt the plaintiff's proposed definition for this term.

VI. "process data in the buffer"

This phrase is used in claims 1 and 10 of the '972 patent. The plaintiff argues the phrase is adequately defined on its own and by the surrounding claim language. The defendants contend the phrase should be defined as "to manipulate data in the buffer in a manner to (a) achieve mapping between Fibre Channel and SCSI devices, and (b) apply access controls and routing functions." See Defendants' Brief, Ex. 2.

The plain language of claims 1 and 10 disclose that the supervisor unit (the microprocessor) processes data in the buffer "to interface between the Fibre Channel controller and the SCSI controller to allow access from Fibre Channel initiator devices to SCSI storage devices using the native low level, block protocol in accordance with the configuration." See '972 Patent, at Claims 1 and 10. This language adequately describes what it means to "process data in the buffer" for these

claims. Simply because the specification may use slightly different language to describe this "processing," *see id.* at 5:18 - 5:20, does not entitle the defendants to adopt the specification language over the plain language of the claims. The Court will not further define this phrase.

VII. "storage router"

This term is used in claims 1-7 and 10 of the '972 patent. The plaintiff argues the term needs no further definition for claims 1-6, and for claim 7 it should be defined as "a device which provides virtual local storage, maps, implements access controls, and allows access using native low level block protocols." *See Plaintiff's Brief*, at 27. The defendants contend the term should mean "a bridge device that connects a Fibre Channel link directly to a SCSI bus and enables the exchange of SCSI command set information between application clients on SCSI bus devices and the Fibre Channel links." *See Defendants' Brief*, Ex. 2.

The defendants do not make any argument for their proposed definition in their brief, and did not discuss the term at the July 25 hearing. In their notebook of exhibits presented at the hearing, the defendants include one page which supports their definition with a quote from the specification. *See Defendants' Markman Exhibits*, "Markman Presentation" Tab, at 22. This argument is disingenuous. The specification language quoted by the defendants is immediately followed by several sentences further defining "storage router." Indeed, the next sentence begins "Further, the storage router applies access controls . . ." *See '972 Patent*, at 5:30. The defendants' attempt to limit the term "storage router" to one of several descriptive sentences in the specification is not well-taken. In addition, the Court finds the term "storage router," as used in all claims of the '972 patent, is adequately described by the additional language of the claims, which discloses in detail the various functions and/or qualities of the storage router. The Court will not further define this term.

VIII. "map"

This term is used in claims 1, 7, 10 and 11 of the '972 patent. The plaintiff contends the term
means "to create a path from a device on one side of the storage router to a device on the other side of the router, i.e. from a Fibre Channel device to a SCSI device (or vice-versa). A 'map' contains a representation of devices on each side of the storage router, so that when a device on one side of the storage router wants to communicate to a device on the other side of the storage router, the storage router can connect the devices." See Plaintiff's Brief, at 22. The defendants argue the term means "to translate addresses." See Defendants' Brief, Ex. 2.

In support of their definition, the defendants point only to a dictionary definition of "map." See Defendants' Brief, at 13 and Ex. 4. The plaintiff, on the other hand, cites to specific portions of the specification that support its definitions of map (both as a verb and a noun) as used in the claims of the '972 patent. See Plaintiff's Brief, at 22 (citing '972 Patent, at 1:66-2:5 and 6:65-7:6). Because intrinsic evidence is far more salient than a dictionary definition, and because the Court agrees that the specification language cited by the plaintiff supports its construction of the term "map," the Court will adopt the plaintiff's proposed definition of this term.

IX. "Fibre Channel protocol unit" and "SCSI protocol unit"

These terms are used in claims 5 and 6 of the '972 patent. The plaintiff contends these phrases should be defined as "a portion of the Fibre Channel controller which connects to the Fibre Channel transport medium" and "a portion of the SCSI controller which interfaces to the SCSI bus." See Plaintiff's Brief, at 27. The defendants say the terms mean "block and equivalents thereof that connects to the Fibre Channel transport medium" and "block and equivalents thereof that connects to the SCSI bus transport medium." See Defendants' Brief, Ex. 2.

The defendants argue the means-plus-function analysis of § 112(6) should apply here because the terms are well-known and are not defined in two dictionaries cited by the defendants. See Defendants' Brief, at 7-8, 14-15, Ex. 4 and Ex. 5. However, the defendants do not indicate how the term should be defined in reference to the specification, and in fact contend "the '972 specification fails to reveal any structure corresponding to the claimed function." See *id.* at 8 and 15. The defendants then propose the word "block" should be used to describe these terms because the "protocol units" are "simply depicted as a block within the diagram of Figure 5" of the '972 patent. See *id.* This reasoning is wholly unpersuasive. Simply because a figure in the patent physically depicts the protocol units in a block-like shape, it does not follow that the units should be defined as "blocks or equivalents thereof." Under that reasoning, the SCSI storage devices, which are physically depicted as cylinders in the '972 patent, could be defined simply as "cylinders, oil drums or monkey barrels, or equivalents thereof." As the plaintiff correctly points out, the language of claims 5 and 6 plainly states that the "protocol units" for both devices are part of the "controllers" for the devices, and are intended to "connect" the devices to various "transport media" (i.e., to various cables). See '972 Patent, at Claims 5 and 6. Accordingly, the Court adopts the plaintiff's definitions for these terms, and will construe the terms to mean "a portion of the Fibre Channel controller which connects to the Fibre Channel transport medium" and "a portion of the SCSI controller which interfaces to the SCSI bus."

X. "interface"

In their Joint Stipulation of Claim Construction, the parties claim the meaning of the term "interface" is in dispute. However, this phrase is not discussed in any of the parties' briefs, and neither side presented an argument at the July 25 hearing as to why the term is disputed. This term

has a standard and ordinary meaning—even to a federal judge—and the Court will not further define it.

XI. Undisputed Terms

Finally, in their Joint Stipulation of Claim Construction, the parties have stipulated to the construction of 17 other terms in the '972 patent. The Court will therefore adopt these stipulated constructions, solely for the purpose of this lawsuit.

Accordingly, the Court enters the following order:

IT IS ORDERED that the attached construction of the patent claims will be incorporated into any jury instructions given in this cause and will be applied by the Court in ruling on the issues raised in summary judgment.

SIGNED on this 2nd day of July 2000.

UNITED STATES DISTRICT JUDGE

RECEIVED 01/21/2000 12:00 PM
CONSTRUCTION OF CLAIMS
U.S. PATENT NO. 5,941,972

Disputed Terms

The phrase "implements access controls for storage space on the SCSI storage devices" means provides controls which limit a computer's access to a specific subset of storage devices or sections of a single storage device.

The phrase "allocation of subsets of storage space to associated Fibre Channel devices, wherein each subset is only accessible by the associated Fibre Channel device" means subsets of storage space are allocated to specific Fibre Channel devices.

A "supervisor unit" is a microprocessor programmed to process data in a buffer in order to map between Fibre Channel devices and SCSI devices and which implements access controls.

A "SCSI storage device" is any storage device including, for example, a tape drive, CD-ROM drive, or a hard disk drive that understands the SCSI protocol and can communicate using the SCSI protocol.

The term "map" means to create a path from a device on one side of the storage router to a device on the other side of the router, i.e. from a Fibre Channel device to a SCSI device (or vice-versa). A "map" contains a representation of devices on each side of the storage router, so that when a device on one side of the storage router wants to communicate with a device on the other side of the storage router, the storage router can connect the devices.

A "Fibre Channel protocol unit" is a portion of the Fibre Channel controller which connects to the Fibre Channel transport medium.

A "SCSI protocol unit" is a portion of the SCSI controller which interfaces to the SCSI bus.

Stipulated / Undisputed Terms

A "buffer" is a memory device that is utilized to temporarily hold data.

A "direct memory access (DMA) interface" is a device that acts under little or no microprocessor control to access memory for data transfer.

A "Fibre Channel" is a known high-speed serial interconnect, the structure and operation of which is described, for example, in Fibre Channel Physical and Signaling Interface (FC-PH), ANSI X3.230 Fibre Channel Arbitrated Loop (FC-AL), and ANSI X3.272 Fibre Channel Private Loop Direct Attach (FC-PLDA).

A "Fibre Channel controller" is a device that interfaces with a Fibre Channel transport medium.

A "Fibre Channel device" is any device, such as a computer, that understands Fibre Channel protocol and can communicate using Fibre Channel protocol.

"Fibre Channel protocol" is a set of rules that apply to Fibre Channel.

A "Fibre Channel transport medium" is a serial optical or electrical communications link that connects devices using Fibre Channel protocol.

A "first-in-first-out queue" is a multi-element data structure from which elements can be removed only in the same order in which they were inserted; that is, it follows a first in, first out (FIFO) constraint.

A "hard disk drive" is a well known magnetic storage media, and includes a SCSI hard disk drive.

An "initiator device" is a device that issues requests for data or storage.

"Maintain(ing) a configuration" means keep(ing) a modifiable setting of information.

A "native low level, block protocol" is a set of rules or standards that enable computers to exchange information and do not involve the overhead of high level protocols and file systems typically required by network servers.

A "SCSI" (Small Computer System Interface) is a high speed parallel interface that may be used to connect components of a computer system.

A "SCSI bus transport medium" is a cable consisting of a group of parallel wires (normally 68) that forms a communications path between a SCSI storage device and another device, such as a computer.

A "SCSI controller" is a device that interfaces with the SCSI bus transport medium.

"Virtual local storage" is a specific subset of overall data stored in storage devices that has the appearance and characteristics of local storage.

A "workstation" is a remote computing device that connects to the Fibre Channel, and may consist of a personal computer.

**This Page is Inserted by IFW Indexing and Scanning
Operations and is not part of the Official Record**

BEST AVAILABLE IMAGES

Defective images within this document are accurate representations of the original documents submitted by the applicant.

Defects in the images include but are not limited to the items checked:

- BLACK BORDERS
- IMAGE CUT OFF AT TOP, BOTTOM OR SIDES
- FADED TEXT OR DRAWING
- BLURRED OR ILLEGIBLE TEXT OR DRAWING
- SKEWED/SLANTED IMAGES
- COLOR OR BLACK AND WHITE PHOTOGRAPHS
- GRAY SCALE DOCUMENTS
- LINES OR MARKS ON ORIGINAL DOCUMENT
- REFERENCE(S) OR EXHIBIT(S) SUBMITTED ARE POOR QUALITY
- OTHER: _____

IMAGES ARE BEST AVAILABLE COPY.

As rescanning these documents will not correct the image problems checked, please do not report these problems to the IFW Image Problem Mailbox.

EXHIBIT D

SS RECEIVED

MAR 10 2003

CLERK, U.S. DISTRICT COURT
WESTERN DISTRICT OF TEXAS
BY [Signature]
DEPUTY CLERK

NOTE: Pursuant to Fed. Cir. R. 47.6, this disposition is not citable as precedent. It is a public record. This disposition will appear in tables published periodically.

United States Court of Appeals for the Federal Circuit

02-1158

FILED

MAR 10 2003

CLERK, U.S. DISTRICT COURT
WESTERN DISTRICT OF TEXAS
BY [Signature]
DEPUTY CLERK

CROSSROADS SYSTEMS, (TEXAS), INC.,

Plaintiff-Appellee,

v.

CHAPARRAL NETWORK STORAGE, INC.,

Defendant-Appellant.

FILED
U.S. COURT OF APPEALS FOR
THE FEDERAL CIRCUIT

FEB 12 2003

JAN HORBALY
CLERK

JUDGMENT

ON APPEAL from the United States District Court for
the Western District of Texas

In CASE NO(S). 00-CV-217 and 00-CV-621

This CAUSE having been heard and considered, it is

ORDERED and ADJUDGED: AFFIRMED. See Fed. Cir. R. 36

Per Curiam (NEWMAN, SCHALL, and DYK, Circuit Judges).

CERTIFIED COPY
I HEREBY CERTIFY THIS DOCUMENT
IS A TRUE AND CORRECT COPY
OF THE ORIGINAL ON FILE.

UNITED STATES COURT OF APPEALS
FOR THE FEDERAL CIRCUIT

By: [Signature] Date: 3/5/03

ENTERED BY ORDER OF THE COURT

DATED: FEB 12 2003

[Signature]
Jan Horbaly, Clerk

ISSUED AS A MANDATE: MARCH 5, 2003

Costs Against Appellant:
Total \$97.35

186

03/17/2003 MON 12:47 PM TX/RY NO 62791



UNITED STATES PATENT AND TRADEMARK OFFICE

UNITED STATES DEPARTMENT OF COMMERCE
United States Patent and Trademark Office
Address: COMMISSIONER FOR PATENTS
P.O. Box 1450
Alexandria, Virginia 22313-1450
www.uspto.gov

APPLICATION NO.	FILING DATE	FIRST NAMED INVENTOR	ATTORNEY DOCKET NO.	CONFIRMATION NO.
90/007,317 <i>90/007,125</i> 44654	11/23/2004 7590 05/24/2005	6425035	HOESEI/WAB	1634
SPRINKLE IP LAW GROUP 1301 W. 25TH STREET SUITE 408 AUSTIN, TX 78705			EXAMINER <i>Fleming, Feitz</i>	
			ART UNIT	PAPER NUMBER
			<i>2182</i>	

DATE MAILED: 05/24/2005

Please find below and/or attached an Office communication concerning this application or proceeding.



**UNITED STATES DEPARTMENT OF COMMERCE
Patent and Trademark Office**

Address: ASSISTANT COMMISSIONER FOR PATENTS

Washington, D.C. 20231

APPLICATION NO./ CONTROL NO.	FILING DATE	FIRST NAMED INVENTOR / PATENT IN REEXAMINATION	ATTORNEY DOCKET NO.
90/007,317	11/23/2004	6425035	HOESE1/WAB

Larry E. Severin
Wang, Hartman & Gibbs, PC
1301 Dove Street
Suite 1050
Newport Beach, CA 92660

EXAMINER

Fleming, Fritz

ART UNIT	PAPER
----------	-------

2182

DATE MAILED: 05/24/05

Please find below and/or attached an Office communication concerning this application or proceeding.

Commissioner of Patents and Trademarks

CC: SPRINKLE IP LAW GROUP
1301 W. 25th Street
Suite 408
Austin, TX 78705



UNITED STATES PATENT AND TRADEMARK OFFICE

Commissioner for Patents
United States Patent and Trademark Office
P. O. Box 1450
Alexandria, VA 22313-1450
www.uspto.gov

DO NOT USE IN PALM PRINTER

(THIRD PARTY REQUESTER'S CORRESPONDENCE ADDRESS)

EX PARTE REEXAMINATION COMMUNICATION TRANSMITTAL FORM

REEXAMINATION CONTROL NO. 90/007,125 merged with 7,317.

PATENT NO. 6425035.

ART UNIT 2182.

Enclosed is a copy of the latest communication from the United States Patent and Trademark Office in the above identified *ex parte* reexamination proceeding (37 CFR 1.550(f)).

Where this copy is supplied after the reply by requester, 37 CFR 1.535, or the time for filing a reply has passed, no submission on behalf of the *ex parte* reexamination requester will be acknowledged or considered (37 CFR 1.550(g)).

Office Action in Ex Parte Reexamination	Control No. 90/007,125 merged with 7,317	Patent Under Reexamination 6425035	
	Examiner Fritz M. Fleming	Art Unit 2182	

-- The MAILING DATE of this communication appears on the cover sheet with the correspondence address --

- a Responsive to the communication(s) filed on 06 April 2005. b This action is made FINAL.
c A statement under 37 CFR 1.530 has not been received from the patent owner.

A shortened statutory period for response to this action is set to expire 2 month(s) from the mailing date of this letter. Failure to respond within the period for response will result in termination of the proceeding and issuance of an *ex parte* reexamination certificate in accordance with this action. 37 CFR 1.550(d). **EXTENSIONS OF TIME ARE GOVERNED BY 37 CFR 1.550(c)**. If the period for response specified above is less than thirty (30) days, a response within the statutory minimum of thirty (30) days will be considered timely.

Part I THE FOLLOWING ATTACHMENT(S) ARE PART OF THIS ACTION:

1. Notice of References Cited by Examiner, PTO-892. 3. Interview Summary, PTO-474.
2. Information Disclosure Statement, PTO-1449. 4. _____

Part II SUMMARY OF ACTION

- 1a. Claims 1-14 are subject to reexamination.
1b. Claims _____ are not subject to reexamination.
2. Claims _____ have been canceled in the present reexamination proceeding.
3. Claims _____ are patentable and/or confirmed.
4. Claims 1-14 are rejected.
5. Claims _____ are objected to.
6. The drawings, filed on 7/19/2004 are acceptable.
7. The proposed drawing correction, filed on _____ has been (7a) approved (7b) disapproved.
8. Acknowledgment is made of the priority claim under 35 U.S.C. § 119(a)-(d) or (f).
a) All b) Some* c) None of the certified copies have
1 been received.
2 not been received.
3 been filed in Application No. _____
4 been filed in reexamination Control No. _____
5 been received by the International Bureau in PCT application No. _____

* See the attached detailed Office action for a list of the certified copies not received.

9. Since the proceeding appears to be in condition for issuance of an *ex parte* reexamination certificate except for formal matters, prosecution as to the merits is closed in accordance with the practice under *Ex parte* Quayle, 1935 C.D. 11, 453 O.G. 213.
10. Other: _____

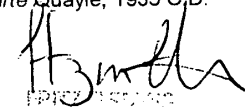
Fritz M. Fleming
Principal Examiner
Art Unit 2182

cc: Requester (if third party requester)

Reexamination

1. In order to ensure full consideration of any amendments, affidavits or declarations, or other documents as evidence of patentability, such documents must be submitted in response to this Office action. Submissions after the next Office action, which is intended to be a final action, will be governed by the requirements of 37 CFR 1.116, which will be strictly enforced.

Extensions of time under 37 CFR 1.136(a) will not be permitted in these proceedings because the provisions of 37 CFR 1.136 apply only to "an applicant" and not to parties in a reexamination proceeding. Additionally, 35 U.S.C. 305 requires that reexamination proceedings "will be conducted with special dispatch" (37 CFR 1.550(a)). Extension of time in *ex parte* reexamination proceedings are provided for in 37 CFR 1.550(c).

2. A shortened statutory period for response to this action is set to expire **2 months from the mailing date of this letter.**

1. The patent owner is reminded of the continuing responsibility under 37 CFR 1.565(a) to apprise the Office of any litigation activity, or other prior or concurrent proceeding, involving Patent No. 6,425,035 throughout the course of this reexamination proceeding. The third party requester is also reminded of the ability to similarly apprise the Office of any such activity or proceeding throughout the course of this reexamination proceeding. See MPEP §§ 2207, 2282 and 2286.

2. Applicant's arguments with respect to claims 1-14 have been considered but are moot in view of the new ground(s) of rejection.

It is to be noted that each independent claim (i.e. 1,7,11) has the phrase "using native low level, block protocols", which per the interview for 90/007127, distinguishes over the art of record used in the first office action. However, instead of being able to close out prosecution with this action, a new non-final action is being issued. This is due to the filing of the IDS after the mailing date of the first office action. Had this information, namely the Spring (UK GB 2297636), been filed prior to the first office action, these issues would have been taken into account in the first office action. Since there was no statement similar to that of 37 CFR 1.97(e), an action based solely upon art cited by the patent owner could have been made final, even when the claims are not amended (see below). Since the art cited by the patent owner led to the discovery of other references used in this rejection, this action cannot be made final, but does certainly delay a final action on the claimed subject matter.

MPEP 2171:

III. ART CITED BY PATENT OWNER DURING PROSECUTION

Where art is submitted in a prior art citation under 37 CFR 1.501 and/or 37 CFR 1.555 (an IDS filed in a reexamination is construed as a prior art citation) and the submission is not accompanied by a statement similar to that of 37 CFR 1.97(e), the examiner may use the art submitted and make the next Office action final whether or not the claims have been amended, provided that no other new ground of rejection is introduced by the examiner based on the new art not cited in the prior art citation. See MPEP § 706.07(a).

Claim Rejections - 35 USC § 103

3. The following is a quotation of 35 U.S.C. 103(a) which forms the basis for all obviousness rejections set forth in this Office action:

(a) A patent may not be obtained though the invention is not identically disclosed or described as set forth in section 102 of this title, if the differences between the subject matter sought to be patented and the prior art are such that the subject matter as a whole would have been obvious at the time the invention was made to a person having ordinary skill in the art to which said subject matter pertains. Patentability shall not be negated by the manner in which the invention was made.

4. The factual inquiries set forth in *Graham v. John Deere Co.*, 383 U.S. 1, 148

USPQ 459 (1966), that are applied for establishing a background for determining

obviousness under 35 U.S.C. 103(a) are summarized as follows:

1. Determining the scope and contents of the prior art.
2. Ascertaining the differences between the prior art and the claims at issue.
3. Resolving the level of ordinary skill in the pertinent art.
4. Considering objective evidence present in the application indicating obviousness or nonobviousness.

5. This application currently names joint inventors. In considering patentability of the claims under 35 U.S.C. 103(a), the examiner presumes that the subject matter of the various claims was commonly owned at the time any inventions covered therein were made absent any evidence to the contrary. Applicant is advised of the obligation under 37 CFR 1.56 to point out the inventor and invention dates of each claim that was not commonly owned at the time a later invention was made in order for the examiner to consider the applicability of 35 U.S.C. 103(c) and potential 35 U.S.C. 102(e), (f) or (g) prior art under 35 U.S.C. 103(a).

6. Claims 7-9,11-14 are rejected under 35 U.S.C. 103(a) as being unpatentable over Spring (UK GB 2297636—Spring) in view of Oeda et al. (Oeda).

Starting with the independent claim 7, one finds an apparatus per Figure 1 comprising a plurality of user workstations (USER 1-4 each having 15-18), a corresponding plurality of first transport medium (un-numbered) connecting the USERS to the storage router (server 20), which in turn is connected to a plurality of storage

devices in the form of drives 1-5 (21-25) via a corresponding set of second transport medium (again un-numbered). Thus the storage router (server 20) interfaces between the workstations and the storage devices, as shown in detail in Figure 2, wherein the processor 28 controls the USER interface circuits 26 and the disk drive interface circuits 27. The internal memory 29 provides programmed instructions for the processor 28. The storage router (server 20) is connected to each USER via a SCSI interface, and in turn to the emulated SCSI drive (drives 21-25). See for example, pages 5-7. Thus, an apparatus for providing virtual local storage (at drives 21-25) on remote storage devices (21-25 are remote from workstations 15/16) connected to one transport medium (the non-numbered connections from the shared file server 20 to the drives 21-25) to devices (workstations 15/16, of which 4 are shown) connected to another transport medium (the un-numbered connections between the workstations 15/16 and the file server 20) is shown in Figure 1. The method of providing virtual local storage is set forth at page 3, wherein it is disclosed that a method of storing data at a large storage volume which emulates (hence makes virtual) a plurality of removable disc drives (the local storage). See also page 10, lines 1-3, wherein step 34 describes a data transfer in which the local operating software **may read and write to logical drives as if they were local removable disc drives**, thereby anticipating the virtual local storage, as the drives themselves are remote to the users, but appear to the user's as the conventional local removable disc drives, and hence virtual local storage as logical drives emulate (i.e. virtual) the removable disc drives (the local storage). Thus the storage router (server 20) interfaces with the first and second transport medium and provides the

virtual local storage to the USERS. There is a mention of a look up table (68) for each logical drive, but such is not the mapping between the workstations and storage devices as claimed, noting that USERS access logical drives. The implementing of access controls is clearly described throughout the disclosure, especially noting that each USER has access to a large number of removable disc drives (see page 7, lines 18-27), thereby teaching the implementation of some sort of access controls, with the storage router (server 20) determining if the requested drive is available, and if so, granting access to the requesting workstation (see page 8, lines 10-17). Thus the access is ultimately controlled and allowed by the storage router (server 20). All of this is done by native low level, block protocol (NLLBP), as the only protocol used from the USERS to the storage router and by the storage router (server 20) is that of the SCSI protocol, such being selected so that the storage router (server 20) will return data back to the USER via the SCSI protocol (page 8, lines 10-17), as the processor 15 (of a USER) issues commands over the SCSI interface (page 8 lines 4-9). Per page 12, lines 14-26, the local operating system of the USER (62) thinks it is accessing a conventional SCSI drive via communications over a conventional SCSI interface to the storage router SCSI interface (65), wherein the communication conforms to establish SCSI protocols without having to embed network software within the workstations. Furthermore, the server operating system (66) converts the SCSI sector definitions into physical data blocks for each logical drive, such that the server operating system (60) emulates an SCSI disc drive per Figure 5. Finally note that the storage router (server 20) grants access to an emulated logical disc drive (page 9, lines 17-19) via mount and dismount commands

(pages 9 and 10) and that the storage router (server 20) has to keep track of user created blocks, such that the USER is presented with a user interface allowing existing logical drives to be selected as well as new logical drives to be defined (page 12, lines 9-13), all via the use of the SCSI NLLBP. Communications between the USERS and the storage router (server 20) is implemented using established protocols, preferred to be SCSI, which is in turn, the claimed use of the NLLBP, as this is used from the USER to the storage router to the disc drives. While look up tables and keeping track of USER blocks is mentioned, this does not set forth a mapping between the workstations and the storage devices, noting that Spring is using logical drives for the USERS.

In the same field of endeavor, Oeda et al. (Oeda) teaches that it is old and well known per Figure 4 to have a plurality of HOSTs (i.e. 1A,B) connected to a SCSI bus (2), which is then in turn connected to a disk controller (5) and a disk drive unit (4). Per Figure 4, it is clearly shown that the disk drive (4) is divided into subsets mapped to the HOSTs, wherein HOST 1A is only allowed to access its partition (41), HOST 1B is only allowed to access its partition (42), and either HOST is granted a shared read only access to the shared partition (43). The partitions (41-43) are assigned to the HOSTs as is shown, with the purpose of the assigned partitions avoiding erroneous partition access and data destruction (column 7, line 53-column 8, line 30). Thus a mapping between workstations (in the form of HOSTs) and the assigned partitions (41-43) is clearly shown, such that a HOST 1A can only request partitions 41 and 43 (the implementing of storage area access controls), and is prevented from erroneously accessing the Host 1B partition 42 (see column 8, lines 13-16), which is the ultimate

allowing of access to only those partitions of the storage area for which access control has been mapped. Furthermore, the disk controller (5 and functioning as a storage router) performs exclusive control between the HOSTs and the drive per Figure 2, wherein the SCSI CONTROL LSI has the ID REGISTERS (71-73) which contains the DEVICE IDs and thus compares the requested device ID by a HOST to the stored IDs and grants or denies access based upon the mapping of Figure 4. Since each partition has a SCSI ID, each partition is seen as a logical drive (and can be assigned different logical unit numbers – LUNs – column 6, lines 34-37), as the HOST sees three separate disk storage devices. The protocol used is that of the SCSI standard, with the 7 phases set forth at column 5, again showing that access from the HOSTs to the storage router (i.e. the disk controller 5 as it performs the mapping, access controls, and granting of access) to the disk drive unit (4) is exclusively SCSI, thus exhibiting the use of a NLLBP as claimed.

Therefore it would have been obvious to one having ordinary skill in the art at the time that the invention was made to modify Spring 636 in view of Oeda for the express purpose of providing a plurality of USERS/HOSTs mapped and controlled access to assigned partitions in order to avoid erroneous disk access and data destruction. In combination, each USER/HOST is granted access to only its subset partition (i.e. logical disk) to which it is mapped. The USERS are a plurality of workstations, and the storage devices are a plurality of disc drives, noting that Oeda supports an array of drives (17) divided into partitions (171-173) such that it performs as a RAID, as does SPRING '636, with each device seen by a HOST independent from one another (Oeda columns 6 and

7). Thus when combined, the plurality of disc drives are divided into partitions mapped to specific USERS/HOSTs, so that access is controlled and granted via the mapping, performed by the storage router (the combined server 20 and disk controller 5).

As far as claims 11-14 are concerned, the method limitations are rendered obvious by the combined teachings of Spring '636 in view of Oeda. For example, the preamble to claim 11 sets forth "one" and "another" transport medium, while the body of the claim only refers to "first" and "second" medium, which only enumerates the medium, but does not require them as being different. Combined, Spring '636 in view of Oeda sets forth the method by which the USERS/HOSTs are interfaced with the disk drives (storage) such that the storage router (the combined teachings of the server 20 and the disk controller 5) provides the claimed mapping, implementing of the access controls, and the allowing access using only the SCSI protocol, which is a NLLBP.

7. Claims 1-6 and 10 are rejected under 35 U.S.C. 103(a) as being unpatentable over Spring '636 in view of Oeda as applied to claims 7-9 and 11-14 above, and further in view of Jibbe et al. (Jibbe).

Spring '636 in view of Oeda set forth the use of a storage router to provide mapping, access control and access granting of USER/HOST requests to the storage disks. Per Spring '636, the server (20) has interfaces (26,27), a CPU (28) connected to the interfaces, and a memory for CPU instructions (29), using SCSI protocol (a NLLBP) end to end. See Figure 2. Per Oeda, the disk controller (5) provides mapping and access control and granting based upon the SCSI CONTROL LSI (6) and the ID REGISTERS (71-73) from the HOSTs (1A,B) to the disk(s) (either 4 or the array17)

using the SCSI protocol (a NLLBP) end to end. What is lacking is the specific detail of the SCSI HOST to SCSI DISK controller.

In the same field of endeavor, Jibbe teaches that it is old and well known to use a SCSI-SCSI controller for HOST to disk array access. See for example, Figure 1, which sets forth the use of a microprocessor (51) coupled to the HOST SCSI interface controller 14 and the SCSI disk drive interface controllers (31-35), such that the microprocessor controls the interfaces (column 4, lines 1-9). The SCSI Array Data Path Chip (ADP 10) interconnects the SCSI data bus (16) with the SCSI data busses (21-25), and is also under the control of the microprocessor controller (51). The DMA FIFO BLOCK 70 holds data received from the host until the array is ready to accept it and to hold data from the disk array until the host is ready to accept it (column 5, lines 14-21). The DMA interface (14) is coupled to the FIFO (70) as well as the first protocol unit (SCSI adapter 14), such that the HOST SCSI adapter (i.e. a first controller) is operable to pull data from and place data into the FIFO (70), with the second controllers (SCSI interfaces 31-35) operable to pull data from and place data into the FIFO (70), under the control of the supervisory unit (microprocessor 51) and its bus (53) that couples it to the interface controllers (14 and 31-35). The memory (36) is a 64kByte SRAM that provides memory workspace during read/modify/write operations of RAID 5 and is also coupled to the microprocessor/supervisor (51) via the ADP (10). Thus the memory (36) and the FIFO (70) provide memory work space for the array controller and allows the microprocessor/supervisor (51) to process data stored therein to allow a HOST to interface with the disk storage. It is also expressly taught that the data path architecture

can be constructed with ESDI, IPI or EISA devices rather than with SCSI devices (column 11, lines 40-43). In summary, Jibbe teaches a supervisor unit 51 coupled to first and second controllers (14 and 31-35), an ADP (10) and buffers (36 and 70), such that the supervisory unit controls the controllers and buffers and the ADP for the express purpose of configurability between RAID 1,3-5 levels, as well as the use of the FIFO buffers for holding data until the host/disk drives are ready. The Host DMA interface (14) is coupled to the SCSI controller (14) and the FIFO buffers/queues (70/101-105) and the buffer (36—internal to the Figure 1 disk array controller).

Therefore it would have been obvious to one having ordinary skill in the art at the time that the invention was made to modify Spring '636 in view of Oeda by the teachings of Jibbe in order to provide for increased RAID functionality via the SCSI disk array controller details, which in turn provide for configurability between various RAID levels (certainly desirable as both Spring '636 and Oeda are concerned with various RAID levels), as well as the ability to buffer data until the host/disks are ready. The combination is proper as Spring '636 and Oeda use SCSI controllers between the host and disk(s) and RAID configurations. Spring '636 even lays out the same basic functionality as Jibbe's array controller in the storage router (server 20), with the required ability to interface with the host and disks via the SCSI protocol. Oeda also provides host to disk interfacing with mapping, access control and access granting in a SCSI protocol environment. It is also to be noted that claims 5 and 6 each depend from claim 1, and thus the single DMA interface of Jibbe that is coupled to the SCSI controller (14) and the disk drive controllers (31-35) meets the claims, because at most,

only one DMA interface is needed at a time via the claim structure. Thus Jibbe provides the details of a SCSI disk array controller needed by Spring '636 and Oeda, and the combined teachings of Spring '636 and Oeda and Jibbe render the claims obvious per the above analysis.

Any inquiry concerning this communication or earlier communications from the examiner should be directed to Fritz M. Fleming whose telephone number is 571-272-4145. The examiner can normally be reached on M-F, 0600-1500.

If attempts to reach the examiner by telephone are unsuccessful, the examiner's supervisor, Jeffrey Gaffin can be reached on 571-272-4146. The fax phone number for the organization where this application or proceeding is assigned is 703-872-9306. Any fax should be sent to the CRU at 571-273-0100.

Information regarding the status of an application may be obtained from the Patent Application Information Retrieval (PAIR) system. Status information for published applications may be obtained from either Private PAIR or Public PAIR. Status information for unpublished applications is available through Private PAIR only. For more information about the PAIR system, see <http://pair-direct.uspto.gov>. Should you have questions on access to the Private PAIR system, contact the Electronic Business Center (EBC) at 866-217-9197 (toll-free).

Fritz M Fleming
Primary Examiner
Art Unit 2182

fmf

Paul L. Ditt
PASCALUS M. LAUFER, PH.D., J.D.
SPECIAL PROGRAM EXAMINER
TECHNOLOGY CENTER 2100

*PERSONAL
MATTERS*

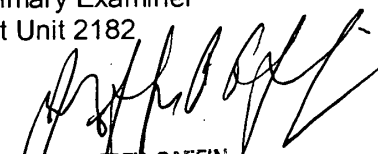
JEFFREY GAFFIN
SUPERVISORY PATENT EXAMINER
TECHNOLOGY CENTER 2100

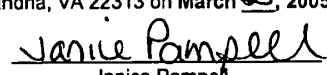

IN THE UNITED STATES PATENT AND TRADEMARK OFFICE	
INFORMATION DISCLOSURE STATEMENT BY APPLICANTS	
Atty. Docket No. (Opt.) CROSS1123-17 CROSS1123-19	
Applicants Geoffrey B. Hoese et al.	
Application Number 90/007,125 90/007,317	Filed 07/19/2004 07/19/2004
For Storage Router and Method for Providing Virtual Local Storage	
Group Art Unit 2182	Examiner Fleming, Fritz M.
Certification Under 37 C.F.R. §1.8	
I hereby certify that this document is being deposited with the United States Postal Service as First Class Mail in an envelope addressed to: Commissioner for Patents, P.O. Box 1450, Alexandria, VA 22313 on March 23, 2005.	
 Janice Pampell	

Commissioner for Patents
P.O. Box 1450
Alexandria, VA 22313

Applicants respectfully request, pursuant to 37 C.F.R. §§ 1.555, 1.56, 1.97 and 1.98, that the art listed on the attached SBO8-A and SBO8-B forms be considered and cited in the examination of the above-identified reexamination application. Since the present Application was filed after June 30, 2003, a copy of any U.S. Patent and any U.S. Patent Application Publications cited on the attached SBO8-A form is not being submitted with this Information Disclosure Statement pursuant to the waiver of 37 C.F.R. S 1.98(a)(2)(i) by the U.S. Patent and Trademark Office. Several documents are included on the enclosed CD-Rom for the convenience of the Examiner. If the Examiner would like hard copies of these documents, we will gladly provide them.

Furthermore, pursuant to 37 C.F.R. §§ 1.97(g) and (h), no representation is made that a search has been made or that this art is material to patentability of the present application. Applicants respectfully submit that the claims of Applicants' above-referenced patent is patentably distinguishable from these references. Applicants respectfully request consideration of these references. The Commissioner is hereby authorized to charge any fees due, or refund any credit, to Deposit Account No. 50-3183 of Sprinkle IP Law Group for any fee under 37 C.F.R. §1.17.

Respectfully submitted,
Sprinkle IP Law Group
Attorneys for Applicants

John L. Adair
Reg. No. 48,828

Dated: *March 23, 2005*
1301 W. 25th Street, Suite 408
Austin, TX 78705
T. 512-637-9220 / F. 512-371-9088



PTO/SB/08A (04-03)

INFORMATION DISCLOSURE STATEMENT BY APPLICANT			Application Number	90/007,125 & 90/007,317	
			Filing Date	07/19/2004	
			First Named Inventor	Hoese, Geoffrey	
			Group Art Unit	2182	
			Examiner Name	Fleming, Fritz M.	
Sheet	1	OF	2	Attorney Docket Number	CROSS1123-17 & CROSS1123-19

U.S. PATENT DOCUMENTS

Examiner Initials	Cite No.	Document Number		Publication Date MM-DD-YYYY	Name of Patentee or Applicant of Cited Document	Pages, Columns, Lines Where Relevant Passages or Figures Appear
		Number	Kind Code (if known)			
FM	A1	3,082,406		03/19/1963	L.D. Stevens	
	A2	4,092,732		05/30/1978	Ouchi	
	A3	4,695,948		09/22/1987	Blevins, et al.	
	A4	4,751,635		06/14/1988	Kret	
	A5	4,864,532		09/05/1989	Reeve, et al.	
	A6	4,947,367		08/07/1990	Chang, et al.	
	A7	5,072,378		12/10/1991	Manka	
	A8	5,163,131		11/10/1992	Row, et al.	
	A9	5,239,632		08/24/1993	Larner	
	A10	5,239,643		08/24/1993	Blount, et al.	
	A11	5,257,386		10/26/1993	Saito	
	A12	5,347,384		09/13/1994	McReynolds, et al.	
	A13	5,414,820		10/09/1995	McFarland, et al.	
	A14	5,423,044		06/06/1995	Sutton, et al.	
	A15	5,465,382		11/07/1995	Day, III, et al.	
	A16	5,530,845		06/25/1996	Hiatt, et al.	
	A17	5,535,352		07/09/1996	Bridges, et al.	
	A18	5,581,714		12/03/1996	Amini, et al.	
	A19	5,596,562		06/21/1997	Chen	
	A20	5,596,736		01/21/1997	Kerns	
	A21	5,598,541		01/28/1997	Malladi	
	A22	5,680,556		10/21/1997	Begun, et al.	
	A23	5,701,491		12/23/1997	Dunn, et al.	
	A24	5,712,976		01/27/1998	Falcon, et al.	
	A25	5,729,705		03/17/1998	Weber	
	A26	5,743,847		04/28/1998	Nakamura, et al.	
	A27	5,751,975		05/12/1998	Gillespie, et al.	
	A28	5,774,683		06/30/1998	Gulick	
	A29	5,845,107		12/01/1998	Fisch, et al.	
	A30	5,857,080		10/05/1999	Jander, et al.	
	A31	5,864,653		01/26/1999	Tavallaei, et al.	
	FM	A32	5,867,648		02/02/1999	Foth, et al.

FMP	A33	5,884,027		03/16/1999	Garbus, et al.	
	A34	5,913,045		06/15/1999	Gillespie, et al.	
	A35	5,923,557		07/13/1999	Eidson	
	A36	5,941,969		08/24/1999	Ram, et al.	
	A37	5,949,994		09/28/1999	Boggs, et al.	
	A38	5,953,511		09/14/1999	Sescilia, et al.	
	A39	5,974,530		10/26/1999	Young	
	A40	5,978,379		11/02/1999	Chan, et al.	
	A41	5,991,797		11/23/1999	Futral, et al.	
	A42	6,000,020		12/07/1999	Chin, et al.	
	A43	6,021,451		02/01/2000	Bell, et al.	
	A44	6,070,253		01/26/1999	Tavallaei, et al.	
	A45	6,131,119		10/10/2000	Fukui	
	A46	6,134,617		10/17/2000	Weber	
	A47	6,141,737		10/31/2000	Krantz, et al.	
	A48	6,145,006		11/07/2000	Vishlitsky, et al.	
	A49	6,223,266		04/24/2001	Sartore	
	A50	6,230,218		05/08/2001	Casper, et al.	
	A51	6,260,120		07/10/2001	Blumenau, et al.	
A52	6,330,629		12/11/2001	Kondo et al.		
A53	6,363,462		03/26/2002	Bergsten		
A54	6,421,753		07/16/2002	Hoese, et al.		
A55	6,425,035		07/23/2002	Hoese, et al.		
A56	6,425,036		07/23/2002	Hoese, et al.		
A57	6,484,245		11/19/2002	Sanada, et al.		
PMP	A59	6,529,996		03/04/2003	Nguyen, et al.	
Examiner Initials	FOREIGN PATENT DOCUMENTS			Publication Date MM-DD-YYYY (Number 43)	Name of Patentee or Applicant of Cited Document	Pages, Columns, Lines Where Relevant Passages or Figures Appear
PMP	B1	GB 2296798	A	07/10/1996	Spring Consultants Limited	
	B2	GB 2297636	A	08/07/1996	Spring Consultants Limited	
	B3	JP 8-230895		09/10/1996	Kikuchi, et al.	
	B4	EP 0810530	A2	12/03/1997	Sun Microsystems, Inc.	
	B5	EP 0827059	A2	03/04/1998	NEC Corporation	
	B6	WO 99/34297	A1	07/08/1999	Crossroads Systems, Inc.	
	B7	GB 2341715				
	B8	JP 6301607				
PMP	B9	WO 98/36357		1998		
Examiner Signature	H. J. M. [Signature]			Date Considered	5/23/2005	

FORM PTO 1449 US Department of Commerce Patent and Trademark Office			Application Number	90/007,125 & 90/007,317	
			Filing Date	July 19, 2004	
			First Named Inventor	Hoese, Geoffrey	
			Group Art Unit	2182	
			Examiner Name	Fleming, Fritz M.	
Sheet	1	of	6	Atty Docket Number	CROSS1123-17 & CROSS1123-19
Examiner Initials	Cite No.	OTHER PRIOR ART – NON PATENT LITERATURE DOCUMENTS		Date	
TAM	C1	Black Box, SCSI Fiberoptic Extender, Single-Ended, Product Insert, 2 pages, 1996.		6/18/05	
	C2	Burskey, Dave "New Serial I/Os Speed Storage Subsystems" February 6, 1996			
	C3	CRD-5500, RAID DISK ARRAY CONTROLLER Product Insert, pp. 1-5			
	C4	CRD-5500, SCSI RAID CONTROLLER OEM Manual, Rev. 1.3, February 26, 1996, pp. 1-54.			
	C5	Raidtec FibreArray and Raidtec FlexArray UltraRAID Systems", Windows IT PRO Article, October 1997.			
	C6	DIGITAL Storage Works, HSZ70 Array Controller, HSOF Version 7.0 EK-HSZ70-CG. A01, Digital Equipment Corporation, Maynard, Massachusetts.			
	C7	DIGITAL StorageWorks, Using Your HSZ70 Array Controller in a SCSI Controller Shelf (DS-BA356-M Series), User's Guide, pp. 1-1 through A-5 with index, January 1998.			
	C8	DIGITAL StorageWorks HSZ270 Array Controller HSOF Version 7.0 EK-HSZ270-RM. A01. CLI Reference Manual			
	C9	DIGITAL Storaeworks HSG80 Array Controller ACS Version 8.0 (User's Guide) 1/98			
	C10	DIGITAL StorageWorks HSZ70 Array Controller HSOF Version 7.0 EK-HSZ70-SV. A01			
	C11	Emerson, "Ancor Communications: Performance evaluation of switched fibre channel I/O system using--FCP for SCSI" February 1995, IEEE, pp. 479-484.			
	C12	IBM Technical Publication: Magstar and IBM 3590 High Performance Tape Subsystem Technical Guide, November 1996, pp. 1-269.			
	C13	Guide to Sharing and Partitioning IBM Tape Library Dataservers, November 1996, IBM, International Technical Support Organization, San Jose Center			
	C14	Misc. Reference Manual Pages, SunOS 5.09.			
	C15	Block-Based Distributed File Systems, Anthony J. McGregor, July 1997.			
	C16	InfoServer 150VXT Photograph			
	C17	Pictures of internal components of the InfoServer 150, taken from http://bindarydinosaurs.couk/Museum/Digital/infoserver/infoserver.php in Nov. 2004.			
	C18	Simplest Migration to Fibre Channel Technology			
	C19	Compaq Storageworks HSG80 Array Controller ACS Version 8.3 (Maintenance and Service Guide) 11/98			
	C20	Compaq Storageworks HSG80 Array Controller ACS Version 8.3 (Configuration and CLI Reference Guide) 11/98			
	C21	Office Action dated 04/21/03 for 10/174,720 (CROSS1120-8).			
TAM	C22	Office Action dated 02/27/01 for 09/354,682 (CROSS1120-1).			

Puz	C23	Office Action dated 08/11/00 for 09/354,682 (CROSS1120-1).	
	C24	Office Action dated 12/16/99 for 09/354,682 (CROSS1120-1).	
	C25	Office Action dated 11/06/02 for 10/023,786 (CROSS1120-4).	
	C26	Office Action dated 01/21/03 for 10/081,110 (CROSS1120-5).	
	C27	Office Action dated 1/27/2005 in 10/658,163 (CROSS1120-13)	
	C28	Office Action in Ex Parte Reexamination 90/007,127, mailed 0207/05.	
	C29	Office Action in Ex Parte Reexamination 90/007,126, mailed 0207/05.	
	C30	Office Action in Ex Parte Reexamination 90/007,124, mailed 0207/05.	
	C31	Office Action in Ex Parte Reexamination 90/007,123, mailed 0207/05.	
	C32	European Office Action issued April 1, 2004 in Application No. 98966104.6-2413	
		Copies of the following are on the attached CD-Rom	
	C33	Defendant's First Supplemental Trial Exhibit List, Crossroads Systems, Inc., v. Chaparral Network Storage, Inc., C.A. No. A-00CA-217-SS (W.D. Tex. 2001). (CD-Rom).	
	C34	Defendant's Third Supplemental Trial Exhibit List, Crossroads Systems, Inc. v. Pathlight Technology, Inc., C.A. No. A-00CA-248-SS (W.D. Tex. 2001) (CD-Rom).	
	C35	Defendant's Trial Exhibits, Crossroads Systems, Inc. v. Pathlight Technology, Inc., C.A. No. A-00CA-248-SS (W.D. Tex. 2001). (CD-Rom).	
	C36	Defendants' Trial Exhibits, Crossroads Systems, Inc., v. Chaparral Network Storage, Inc., C.A. No. A-00CA-217-SS (W.D. Tex. 2001). (CD-Rom).	
	C37	Defendant Chaparral Network Storage, Inc.'s First Supplemental Trial Exhibit List (D1 through D271) (CD-ROM Chaparral Exhibits ExList_Def).	9/2/2001
	C38	Defendant Pathlight Technology Inc.'s Third Supplemental Trial Exhibit List (CD-ROM Pathlight Exhibits ExList_Def).	
	C39	Plaintiff's Fourth Amended Trail Exhibit List, Crossroads Systems, Inc. v. Chaparral Network Storage, Inc, C.A. No. A-00CA-217-SS (W.D. Tex. 2001) (CD-Rom).	9/11/2001
	C40	Plaintiff's Revised Trial Exhibit List, Crossroads Systems, Inc. v. Pathlight Technology, Inc., C.A. No. A-00CA-248-SS (W.D. Tex. 2001). (CD-Rom).	
	C41	Plaintiff's Trial Exhibits, Crossroads Systems, Inc. v. Chaparral Networks Storage, Inc., C.A. No. A-00CA-217-SS (W.D. Tex. 2001). (CD-Rom).	
	C42	Plaintiff's Fourth Amended Trail Exhibit List (CD-ROM Chaparral Exhibits ExList_Plaintiff).	9/11/2001
	C43	Plaintiff's Revised Trail Exhibit List (CD-ROM Pathlight Exhibits ExList_Plaintiff).	
	C44	Trail Transcripts, Crossroads Systems, Inc. v. Chaparral Network Storage, Inc., C.A. No. A-00CA-217-SS (W.D. Tex. 2001) (CD-Rom).	
	C45	Trail Transcripts, Crossroads Systems, Inc. v. Pathlight Technology, Inc., C.A. No. A-00CA-248-SS (W.D. Tex. 2001). (CD-Rom).	
	C46	Trial Exhibits and Transcripts, Crossroads v. Chaparral, Civil Action No. A-00CA-21755, W.D. Tex. 2000 (CD-Rom and hard copy printouts).	
	C47	Snively, "Sun Microsystem Computer Corporation: Implementing a fibre optic channel SCSI transport" 1994 IEEE, February 28, 1994, pp. 78-82.	
Puz	C48	Datasheet for CrossPoint 4100 Fibre Channel to SCSI Router (Dedek Ex 41 (ANCT 117-120)) (CD-ROM Chaparral Exhibits D012).	

FWZ	C49	Symbios Logic- Software Interface Specification Series 3 SCSI RAID Controller Software Release 02.xx (Engelbrecht Ex 2 (LSI 1421-1658)) (CD-ROM Chaparral Exhibits D013).	12/3/1997
	C50	Press Release- Symbios Logic to Demonstrate Strong Support for Fibre Channel at Fall Comdex (Engelbrecht 12 (LSI 2785-86)) (CD-ROM Chaparral Exhibits D016).	11/13/1996
	C51	OEM Datasheet on the 3701 Controller (Engelbrecht 13 (LSI 01837-38)) (CD-ROM Chaparral Exhibits D017).	6/17/1905
	C52	Nondisclosure Agreement Between Adaptec and Crossroads Dated 10/17/96 (Quisenberry Ex 25 (CRDS 8196)) (CD-ROM Chaparral Exhibits D020).	10/17/1996
	C53	Organizational Presentation on the External Storage Group (Lavan Ex 1 (CNS 182242-255)) (CD-ROM Chaparral Exhibits D021).	4/11/1996
	C54	Bridge. C, Bridge Between SCSI-2 and SCSI-3 FCP (Fibre Channel Protocol) (CD-ROM Chaparral Exhibits P214).	
	C55	Bridge Phase II Architecture Presentation (Lavan Ex 2 (CNS 182287-295)) (CD-ROM Chaparral Exhibits D022).	4/12/1996
	C56	Attendees/Action Items from 4/12/96 Meeting at BTC (Lavan Ex 3 (CNS 182241)) (CD-ROM Chaparral Exhibits D023).	4/12/1996
	C57	Brooklyn Hardware Engineering Requirements Documents, Revision 1.4 (Lavan Ex 4 (CNS 178188-211)) (CD-ROM Chaparral Exhibits D024) by Pecone.	5/26/1996
	C58	Brooklyn Single-Ended SCSI RAID Bridge Controller Hardware OEM Manual, Revision 2.1 (Lavan EX 5 (CNS 177169-191)) (CD-ROM Chaparral Exhibits D025).	3/21/1996
	C59	Coronado Hardware Engineering Requirements Document, Revision 0.0 (Lavan Ex 7 (CNS 176917-932)) (CD-ROM Chaparral Exhibits D027) by O'Dell.	9/30/1996
	C60	ESS/FPG Organization (Lavan Ex 8 (CNS 178639-652)) (CD-ROM Chaparral Exhibits D028).	12/6/1996
	C61	Adaptec MCS ESS Presents: Intelligent External I/O Raid Controllers "Bridge" Strategy (Lavan Ex 9 (CNS 178606-638)). (CD-ROM Chaparral Exhibits D029).	2/6/1996
	C62	AEC-7313 Fibre Channel Daughter Board (for Brooklyn) Engineering Specification, Revision 1.0 (Lavan Ex 10 (CNS 176830-850)) (CD-ROM Chaparral Exhibits D030).	2/27/1997
	C63	Bill of Material (Lavan Ex 14 (CNS 177211-214)) (CD-ROM Chaparral Exhibits D034).	7/24/1997
	C64	AEC- 4412B, AEC-7412/B2 External RAID Controller Hardware OEM Manual, Revision 2.0 (Lavan Ex 15 (CNS 177082-123)) (CD-ROM Chaparral Exhibits D035).	6/27/1997
	C65	Coronado II, AEC-7312A Fibre Channel Daughter (for Brooklyn) Hardware Specification, Revision 1.2 (Lavan Ex 16 (CNS 177192-210)) (CD-ROM Chaparral Exhibits D037) by Tom Yang.	7/18/1997
	C66	AEC-4412B, AEC7412/3B External RAID Controller Hardware OEM Manual, Revision 3.0. (Lavan Ex 17 (CNS 177124-165)) (CD-ROM Chaparral Exhibits D036).	8/25/1997
	C67	Memo Dated 8/15/97 to AEC-7312A Evaluation Unit Customers re: B001 Release Notes (Lavan Ex 18 (CNS 182878-879)) (CD-ROM Chaparral Exhibits D038).	8/15/1997
	C68	Brooklyn Main Board (AES-0302) MES Schedule (Lavan Ex 19 (CNS 17759-763)) (CD-ROM Chaparral Exhibits D039).	2/11/1997
FWZ	C69	News Release-Adaptec Adds Fibre Channel Option to its External RAID Controller Family (Lavan Ex 20 (CNS 182932-934)) (CD-ROM Chaparral Exhibits D040).	5/6/1997

<i>PCP</i>	C70	AEC-4412B/7412B User's Guide, Rev. A (Lavan Ex 21) (CD-ROM Chaparral Exhibits D041).	6/19/1905
	C71	Data Book- AIC-7895 PCI Bus Master Single Chip SCSI Host Adapter (Davies Ex 1 (CNS 182944-64)) (CD-ROM Chaparral Exhibits D046).	5/21/1996
	C72	Data Book- AIC-1160 Fibre Channel Host Adapter ASIC (Davies Ex 2 (CNS 181800-825)) (CD-ROM Chaparral Exhibits D047).	6/18/1905
	C73	Viking RAID Software (Davies Ex 3 (CNS 180969-181026)) (CD-ROM Chaparral Exhibits D048).	6/18/1905
	C74	Header File with Structure Definitions (Davies Ex 4 (CNS 180009-018)) (CD-ROM Chaparral Exhibits D049).	8/8/1996
	C75	C++ SourceCode for the SCSI Command Handler (Davies Ex 5 (CNS 179136-168)) (CD-ROM Chaparral Exhibits D050).	8/8/1996
	C76	Header File Data Structure (Davies Ex 6 (CNS 179997-180008)) (CD-ROM Chaparral Exhibits D051).	1/2/1997
	C77	SCSI Command Handler (Davies Ex 7 (CNS 179676-719)) (CD-ROM Chaparral Exhibits D052).	1/2/1997
	C78	Coronado: Fibre Channel to SCSI Intelligent RAID Controller Product Brief (Kalwitz Ex I (CNS 182804-805)) (CD-ROM Chaparral Exhibits D053).	}
	C79	Bill of Material (Kalwitz Ex 2 (CNS 181632-633)) (CD-ROM Chaparral Exhibits D054).	3/17/1997
	C80	Emails Dated 1/13-3/31/97 from P. Collins to Mo re: Status Reports (Kalwitz Ex 3 (CNS 182501-511)) (CD-ROM Chaparral Exhibits D055).	}
	C81	Hardware Schematics for the Fibre Channel Daughtercard Coronado (Kalwitz Ex 4 (CNS 181639-648)) (CD-ROM Chaparral Exhibits D056).	}
	C82	Adaptec Schematics re AAC-340 (Kalwitz Ex 14 CNS 177215-251)) (CD-ROM Chaparral Exhibits D057).	}
	C83	Bridge Product Line Review (Manzanares Ex 3 (CNS 177307-336)) (CD-ROM Chaparral Exhibits D058).	}
	C84	AEC Bridge Series Products-Adaptec External Controller RAID Products Pre-Release Draft, v.6 (Manzanares Ex 4 (CNS 174632-653)). (CD-ROM Chaparral Exhibits D059).	10/28/1997
	C85	Hewlett-Packard Roseville Site Property Pass for Brian Smith (Dunning Ex 14 (HP 489)) (CD-ROM Chaparral Exhibits D078).	11/7/1996
	C86	Distribution Agreement Between Hewlett-Packard and Crossroads (Dunning Ex 15 (HP 326-33)) (CD-ROM Chaparral Exhibits D079).	}
	C87	HPFC-5000 Tachyon User's Manuel, First Edition (PTI 172419-839) (CD-ROM Chaparral Exhibits D084).	5/1/1996
	C88	X3T10 994D - (Draft) Information Technology: SCSI-3 Architecture Model, Rev. 1.8 (PTI 165977) (CD-ROM Chaparral Exhibits D087).	}
	C89	X3T10 Project 1047D: Information Technology- SCSI-3 Controller Commands (SCC), Rev, 6c (PTI 166400-546) (CD-ROM Chaparral Exhibits D088).	9/3/1996
	C90	X3T10 995D- (Draft) SCSI-3 Primary Commands, Rev. 11 (Wanamaker Ex 5 (PTI 166050-229)) (CD-ROM Chaparral Exhibits D089).	11/13/1996
	C91	VBAR Volume Backup and Restore (CRDS 12200-202) (CD-ROM Chaparral Exhibits D099).	}
	C92	Preliminary Product Literature for Infinity Commstor's Fibre Channel to SCSI Protocol Bridge (Smith Ex 11; Quisenberry Ex 31 (SPLO 428-30)) (CD-ROM Chaparral Exhibits D143).	8/19/1996
<i>PCP</i>	C93	Letter dated 7/12/96 from J. Boykin to B. Smith re: Purchase Order for Evaluation Units from Crossroads (Smith Ex 24) CRDS 8556-57) (CD-ROM Chaparral Exhibits D144).	7/12/1996

DF	C94	CrossPoint 4100 Fibre Channel to SCSI Router Preliminary Datasheet (Hulsey Ex 9 (CRDS 16129-130)) (CD-ROM Chaparral Exhibits D145).	11/1/1996
	C95	CrossPoint 4400 Fibre Channel to SCSI Router Preliminary Datasheet (Bardach Ex. 9, Quisenberry Ex 33 (CRDS 25606-607)) (CD-ROM Chaparral Exhibits D153).	11/1/1996
	C96	Fax Dated 07/22/96 from L. Petti to B. Smith re: Purchase Order from Data General for FC2S Fibre to Channel SCSI Protocol Bridge Model 11 (Smith Ex 25; Quisenberry Ex 23; Bardach Ex 11 (CRDS 8552-55; 8558) (CD-ROM Chaparral Exhibits D155).	
	C97	Email Dated 12/20/96 from J. Boykin to B. Smith re: Purchase Order for Betas in February and March (Hoese Ex 16, Quisenberry Ex 25; Bardach Ex 12 (CRDS 13644-650) (CD-ROM Chaparral Exhibits D156).	
	C98	Infinity Commstor Fibre Channel Demo for Fall Comdex, 1996 (Hoese Ex 15, Bardach Ex 13 (CRDS 27415) (CD-ROM Chaparral Exhibits D157).	
	C99	Fax Dated 12/19/96 from B. Bardach to T. Rarich re: Purchase Order Information (Bardach Ex. 14; Smith Ex 16 (CRDS 4460)) (CD-ROM Chaparral Exhibits D158).	
	C100	Miscellaneous Documents Regarding Comdex (Quisenberry Ex 2 (CRDS 27415-465)) (CD-ROM Chaparral Exhibits D165).	
	C101	CrossPoint 4100 Fibre Channel to SCSI Router Preliminary Datasheet (Quisenberry) Ex 3 (CRDS 4933-34) (CD-ROM Chaparral Exhibits D166) (CD-ROM Chaparral Exhibits D166).	
	C102	CrossPoint 4400 Fibre to Channel to SCSI Router Preliminary Datasheet; Crossroads Company and Product Overview (Quisenberry Ex 4 (CRDS 25606; 16136)) (CD-ROM Chaparral Exhibits D167).	
	C103	Crossroads Purchase Order Log (Quisenberry Ex 9 (CRDS 14061-062)) (CD-ROM Chaparral Exhibits D172).	
	C104	RAID Manager 5 with RDAC 5 for UNIX V.4 User's Guide (LSI-01854) (CD-ROM Chaparral Exhibits P062).	9/1/1996
	C105	Letter dated May 12, 1997 from Alan G. Leal to Barbara Bardach enclosing the original OEM License and Purchase Agreement between Hewlett-Packard Company and Crossroads Systems, Inc. (CRDS 02057) (CD-ROM Chaparral Exhibits P130).	
	C106	CR4x00 Product Specification (CRDS 43929) (CD-ROM Chaparral Exhibits P267).	6/1/1998
	C107	Symbios Logic - Hardware Functional Specification for the Symbios Logic Series 3 Fibre Channel Disk Array Controller Model 3701 (Engelbrecht Ex 3 (LSI-1659-1733) (CD-ROM Pathlight Exhibits D074).	
	C108	Report of the Working Group on Storage I/O for Large Scale Computing; Department of Computer Science Duke University: CS-1996-21 (PTI 173330-347). (CD-ROM Pathlight Exhibits D098).	
	C109	Brian Allison's 1999 Third Quarter Sales Plan (PDX 38) CNS 022120-132) (CD-ROM Pathlight Exhibits D201).	6/5/2001
Puz	C110	Brooklyn SCSI-SCSI Intelligent External RAID Bridge Definition Phase External Documentation (CD-ROM Pathlight Exhibits D129).	
Examiner Signature		<i>ftzm</i>	Date Considered
			5/23/2005

Notice of References Cited	Application/Control No. 90/007,125 merged with 7,317	Applicant(s)/Patent Under Reexamination 6425035	
	Examiner Fritz M. Fleming	Art Unit 2182	Page 1 of 1

U.S. PATENT DOCUMENTS

*	Document Number Country Code-Number-Kind Code	Date MM-YYYY	Name	Classification
A	US-5,345,565 A	09-1994	Jibbe et al.	710/316
B	US-5,634,111	05-1997	Oeda et al.	711/153
C	US-			
D	US-			
E	US-			
F	US-			
G	US-			
H	US-			
I	US-			
J	US-			
K	US-			
L	US-			
M	US-			

FOREIGN PATENT DOCUMENTS

*	Document Number Country Code-Number-Kind Code	Date MM-YYYY	Country	Name	Classification
N					
O					
P					
Q					
R					
S					
T					

NON-PATENT DOCUMENTS

*	Include as applicable: Author, Title Date, Publisher, Edition or Volume, Pertinent Pages)
U	
V	
W	
X	

*A copy of this reference is not being furnished with this Office action. (See MPEP § 707.05(a).)
Dates in MM-YYYY format are publication dates. Classifications may be US or foreign.

Index of Claims



Application No.

90/007,125 merged with 7,317

Applicant(s)

6425035

Examiner

Fritz M Fleming

Art Unit

2182

√	Rejected
=	Allowed

-	(Through numeral) Cancelled
+	Restricted

N	Non-Elected
I	Interference

A	Appeal
O	Objected

Claim		Date	
Final	Original		
	1		
	2		
	3		
	4		
	5		
	6		
	7		
	8		
	9		
	10		
	11		
	12		
	13		
	14		
	15		
	16		
	17		
	18		
	19		
	20		
	21		
	22		
	23		
	24		
	25		
	26		
	27		
	28		
	29		
	30		
	31		
	32		
	33		
	34		
	35		
	36		
	37		
	38		
	39		
	40		
	41		
	42		
	43		
	44		
	45		
	46		
	47		
	48		
	49		
	50		

Claim		Date	
Final	Original		
	51		
	52		
	53		
	54		
	55		
	56		
	57		
	58		
	59		
	60		
	61		
	62		
	63		
	64		
	65		
	66		
	67		
	68		
	69		
	70		
	71		
	72		
	73		
	74		
	75		
	76		
	77		
	78		
	79		
	80		
	81		
	82		
	83		
	84		
	85		
	86		
	87		
	88		
	89		
	90		
	91		
	92		
	93		
	94		
	95		
	96		
	97		
	98		
	99		
	100		

Claim		Date	
Final	Original		
	101		
	102		
	103		
	104		
	105		
	106		
	107		
	108		
	109		
	110		
	111		
	112		
	113		
	114		
	115		
	116		
	117		
	118		
	119		
	120		
	121		
	122		
	123		
	124		
	125		
	126		
	127		
	128		
	129		
	130		
	131		
	132		
	133		
	134		
	135		
	136		
	137		
	138		
	139		
	140		
	141		
	142		
	143		
	144		
	145		
	146		
	147		
	148		
	149		
	150		

RE Exam



IN THE UNITED STATES PATENT AND TRADEMARK OFFICE	
CHANGE OF POWER OF ATTORNEY AND CORRESPONDENCE ADDRESS	
Atty. Docket No. CROSS1123-19	
Applicant Geoffrey B. Hoese, et al.	
Application Number 90/007,317	Date Filed 11-23-2004
Title Storage Router and Method for Providing Virtual Local Storage	
Group Art Unit 2182	Examiner Fleming, Fritz

Applicant hereby served the attached Revocation and Power of Attorney and Change of Mailing Address on Third Party Requesters at the address listed below:

Larry E. Severin
Wang, Hartmann & Gibbs, PC
1301 Dove Street, #1050
Newport Beach, CA 92660

And

William A. Blake
Jones, Tullar & Cooper, PC
P.O. Box 2226 Eads Station
Alexandria, VA 22202

As per 35 U.S.C. §1.248 service was made via first class mail on April 8, 2005.

Respectfully submitted,

Sprinkle IP Law Group

John L. Adair
Reg. No. 48,828

Dated: April 8, 2005

1301 W. 25th Street, Suite 408
Austin, Texas 78705
Tel. (512) 637-9220
Fax. (512) 371-9088

Enclosures

IN THE UNITED STATES PATENT AND TRADEMARK OFFICE	
REVOCAION AND POWER OF ATTORNEY AND CHANGE OF MAILING ADDRESS	Atty. Docket No. CROSS1123-19



Applicants Geoffrey B. Hoese. et al.	
Application No. 90/007,317	Filing Date 11/23/2004
For Storage Router and Method for Providing Virtual Local Storage	
Group Art Unit 2182	Examiner Fleming, Fritz
Confirmation No. 1634	

Commissioner for Patents
P.O. Box 1450
Alexandria, VA 22313-1450

Dear Sir:

Certification Under 37 C.F.R. §1.8
I hereby certify that this document is being transmitted to the U.S. Patent Office, COMMISSIONER FOR PATENTS via facsimile on <u>4-8-</u> , 2005.
 Janice Pampell

Crossroads Systems, Inc., 100% owner of the above-identified patent application, as evidenced by the Assignment recorded in the parent application on December 31, 1997 on Reel/Frame: 8929/0290, hereby revokes all previous Powers of Attorney and appoints the following attorneys under Customer No. 44654, all of the firm of SPRINKLE IP LAW GROUP, to prosecute the above-identified Patent and to transact all business in the Patent and Trademark Office connected therewith.

STEVEN R. SPRINKLE
JOHN ADAIR
ARI AKMAL

Registration No. 40,825
Registration No. 48,828
Registration No. 51,388

Direct all telephone calls and correspondence to:

Customer No. 44654
SPRINKLE IP LAW GROUP
1301 W. 25th Street, Suite 408
Austin, Texas 78705
Attn: Steven Sprinkle
Tel. (512) 637.9220 / Fax (512) 371.9088

I hereby state I am authorized to act on behalf of Crossroads Systems, Inc.

Respectfully submitted,

Crossroads Systems, Inc.

Dated: April 7, 2005

By:
Robert Sims, President & CEO



P.O. Box 684767
Austin, Texas 78768-4767
[o] 512.637.9220
[f] 512.371.9088

FAX COVER SHEET

TO:	U.S. Patent Office	Fax#:	703-872-9306
FROM:	Steve Sprinkle	Client Matter #:	CROSS1123-19
DATE:	09/27/04	# of Pages:	2
RE:	Revocations and Power of Attorney		

Please contact 512.637.9225 if there is a problem with this transmission.

CONFIDENTIALITY NOTICE

This communication is ONLY for the person named above. Unless otherwise indicated, it contains information that is confidential, privileged or exempt from disclosure under applicable law. If you are not the person named above, or responsible for delivering it to that person, be aware that disclosure, copying, distribution or use of this communication is strictly PROHIBITED. If you have received it in error, or are uncertain as to its proper handling, please immediately notify us by telephone and mail the original to us at the above address. Thank you.

PAGE 1/2 * RCVD AT 4/8/2005 1:45:40 PM [Eastern Daylight Time] * SVR:USPTO-EFXRF-1/2 * DNS:8729306 * CSID:5123719088 * DURATION (mm:ss):01-00

IN THE UNITED STATES PATENT AND TRADEMARK OFFICE	
REVOCATION AND POWER OF ATTORNEY AND CHANGE OF MAILING ADDRESS	Atty. Docket No. CROSS1123-19
Applicants Geoffrey B. Hoese. et al.	
Application No. 90/007,317	Filing Date 11/23/2004
For Storage Router and Method for Providing Virtual Local Storage	
Group Art Unit 2182	Examiner Fleming, Fritz
Confirmation No. 1634	

Commissioner for Patents
P.O. Box 1450
Alexandria, VA 22313-1450

Dear Sir:

<u>Certification Under 37 C.F.R. §1.8</u>
I hereby certify that this document is being transmitted to the U.S. Patent Office, COMMISSIONER FOR PATENTS via facsimile on <u>4-8-</u> 2005.
 Janice Pampell

Crossroads Systems, Inc., 100% owner of the above-identified patent application, as evidenced by the Assignment recorded in the parent application on December 31, 1997 on Reel/Frame: 8929/0290, hereby revokes all previous Powers of Attorney and appoints the following attorneys under Customer No. 44654, all of the firm of SPRINKLE IP LAW GROUP, to prosecute the above-identified Patent and to transact all business in the Patent and Trademark Office connected therewith.

STEVEN R. SPRINKLE
JOHN ADAIR
ARI AKMAL

Registration No. 40,825
Registration No. 48,828
Registration No. 51,388

Direct all telephone calls and correspondence to:

Customer No. 44654
SPRINKLE IP LAW GROUP
1301 W. 25th Street, Suite 408
Austin, Texas 78705
Attn: Steven Sprinkle
Tel. (512) 637.9220 / Fax (512) 371.9088

I hereby state I am authorized to act on behalf of Crossroads Systems, Inc.

Respectfully submitted,

Crossroads Systems, Inc.

Dated: April 7, 2005

By: 
Robert Sims, President & CEO

IN THE UNITED STATES PATENT AND TRADEMARK OFFICE	
CERTIFICATE OF SERVICE UNDER 37 C.F.R. 1.248	Atty. Docket No. CROSS1123-17 CROSS1123-19
Applicant Geoffrey B. Hoese, et al.	
Reexamination Control No. 90/007,125 90/007,317	Date Filed 07/19/2004 11/23/2004
Title Storage Router and Method for Providing Virtual Local Storage	
Group Art Unit 2182	Examiner Fleming, Fritz

Applicant hereby serves the Reply to Office Action Under *Ex Parte* Reexamination Dated 02/07/05 in the above referenced case to:

Larry E. Severin
Wang, Hartmann & Gibbs, PC
1301 Dove Street, #1050
Newport Beach, CA 92660

William A. Blake
Jones, Tullar & Cooper, PC
P.O. Box 2226 Eads Station
Alexandria, VA 22202

As per 35 U.S.C. §1.248 service is made via first class mail on April 6, 2005.

Respectfully submitted,

Sprinkle IP Law Group

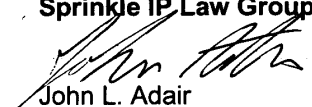
John L. Adair
Reg. No. 48,828

Dated: April 6, 2005

1301 W. 25th Street, Suite 408
Austin, Texas 78705
Tel. (512) 637-9220
Fax. (512) 371-9088

Enclosures

IN THE UNITED STATES PATENT AND TRADEMARK OFFICE

**REPLY TO OFFICE ACTION UNDER *EX PARTE*
REEXAMINATION DATED 02/07/05**

Atty. Docket No.
**CROSS1123-17
CROSS1123-19**

Applicants Geoffrey B. Hoese, et al.	
Reexamination Control Number 90/007,125 90/007,317	Date Filed 07/19/2004 11/23/2004
Title Storage Router and Method for Providing Virtual Local Storage	
Group Art Unit 2182	Examiner Fleming, Fritz
Confirmation Number: 2298	Patent No. 6,425,035

6548 U.S. PTO



Commissioner for Patents
P.O. Box 1450
Alexandria, VA 22313-1450

Dear Sir:

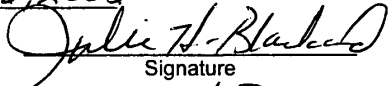
Certificate of Mailing Under 37 C.F.R. §1.10
I hereby certify that this correspondence is being deposited with the United States Postal Service as Express Mail No. EV616964321US in an envelope addressed to Commissioner for Patents, P.O. Box 1450, Alexandria, VA 22312-1450 on <u>April 6, 2005</u>
 Signature
JULIE H. BLACKARD Printed Name

In response to the Official Action mailed February 7, 2005, Applicant respectfully requests the Examiner reconsider the rejections of the Claims in the Re-Examination of U.S. Patent 6,425,035 (the "035 Patent") in view of the this reply.

IN THE CLAIMS:

1. A storage router for providing virtual local storage on remote storage devices to devices, comprising:
a buffer providing memory work space for the storage router;
a first controller operable to connect to and interface with a first transport medium;
a second controller operable to connect to and interface with a second transport medium; and
a supervisor unit coupled to the first controller, the second controller and the buffer, the supervisor unit operable to map between devices connected to the first transport medium and the storage devices, to implement access controls for storage space on the storage devices and to process data in the buffer to interface between the first controller and the second controller to allow access from devices connected to the first transport medium to the storage devices using native low level, block protocols.
2. The storage router of claim 1, wherein the supervisor unit maintains an allocation of subsets of storage space to associated devices connected to the first transport medium; wherein each subset is only accessible by the associated device connected to the first transport medium.
3. The storage router of claim 2, wherein the devices connected to the first transport medium comprise workstations.
4. The storage router of claim 2, wherein the storage devices comprise hard disk drives.
5. The storage router of claim 1, wherein the first controller comprises:
a first protocol unit operable to connect to the first transport medium;
a first-in-first-out queue coupled to the first protocol unit; and
a direct memory access (DMA) interface coupled to the first-in-first-out queue and to the buffer.
6. The storage router of claim 1, wherein the second controller comprises:
a second protocol unit operable to connect to the second transport medium;
an internal buffer coupled to the second protocol unit; and

a direct memory access (DMA) interface coupled to the internal buffer and to the buffer of the storage router.

7. A storage network, comprising:
a first transport medium;
a second transport medium;
a plurality of workstations connected to the first transport medium;
a plurality of storage devices connected to the second transport medium; and
a storage router interfacing between the first transport medium and the second transport medium, the storage router providing virtual local storage on the storage devices to the workstations and operable:
to map between the workstations and the storage devices;
to implement access controls for storage space on the storage devices; and
to allow access from the workstations to the storage devices using native low level, block protocol in accordance with the mapping and access controls.

8. The storage network of claim 7, wherein the access controls include an allocation of subsets of storage space to associated workstations, wherein each subset is only accessible by the associated workstation.

9. The storage network of claim 7, wherein the storage devices comprise hard disk drives.

10. The storage network of claim 7, wherein the storage router comprises:
a buffer providing memory work space for the storage router;
a first controller operable to connect to and interface with the first transport medium, the first controller further operable to pull outgoing data from the buffer and to place incoming data into the buffer;
a second controller operable to connect to and interface with the second transport medium, the second controller further operable to pull outgoing data from the buffer and to place incoming data into the buffer; and
a supervisor unit coupled to the first controller, the second controller and the buffer, the supervisor unit operable:

to map between devices connected to the first transport medium and the storage devices, to implement the access controls for storage space on the storage devices and to process data in the buffer to interface between the first controller and the second controller to allow access from workstations to storage devices.

11. A method for providing virtual local storage on remote storage devices connected to one transport medium to devices connected to another transport medium, comprising:

- interfacing with a first transport medium;
- interfacing with a second transport medium;
- mapping between devices connected to the first transport medium and the storage devices and implementing access controls for storage space on the storage devices;
- and
- allowing access from devices connected to the first transport medium to the storage devices using native low level, block protocols.

12. The method of claim 11, wherein mapping between devices connected to the first transport medium and the storage devices includes allocating subsets of storage space to associated devices connected to the first transport medium, wherein each subset is only accessible by the associated device connected to the first transport medium.

13. The method of claim 12, wherein the devices connected to the first transport medium comprise workstations.

14. The method of claim 12, wherein the storage devices comprise hard disk drives.

TABLE OF CONTENTS

- I. Rejections Under 35 U.S.C. § 102(b)
 - A. Introduction
 - B. Claims 11-14
 - 1. Overview of Claim 11
 - 2. Petal Does Not Disclose "Allowing Access" From A Workstation
Using NLLBP
 - 3. Petal Does Not Disclose "Mapping Between Devices Connected
To The First Transport Medium And The Storage Devices"
 - 4. Petal Does Not Disclose Implementing "Access Controls"
 - a. Implementing Access Controls Requires Allowing Access
Using NLLBPs
 - b. Petal Is Not An Anticipatory Reference Because Petal
Does Not Enable Access Controls
 - c. There Is No Disclosure or Teaching In Petal That The
'Security' Referenced Therein Would Allow Access Using NLLBP
 - d. Petal Does Not Render The Access Controls Limitation of
Claim 11 Obvious
 - 5. Claim 12
 - 6. Summary
 - C. Claims 7-10
 - 1. Overview of Claim 7
 - 2. Petal Does Not Disclose "Allow[ing] Access" From A Workstation
Using NLLBP
 - 3. Petal Does Not Disclose a "Map" Between Workstations And
Storage Devices
 - 4. Petal Does Not Provide Access Through "Access Controls"
 - 5. Claim 8
 - 6. Summary

- II. Rejections Under 35 U.S.C. § 103
- A. Introduction
- B. Claim 1

1. Overview of Claim 1
2. Petal Does Not Disclose "Allow[ing] Access" From A Workstation

Using NLLBP

3. Petal Does Not Disclose a "Map" Between Devices On The First Transport Medium and Storage Devices

4. Petal Does Not Disclose, Teach or Suggest the "Access Controls" Limitation Of Claim 1

5. There Is No Showing That The Remainder Of The References Contain The Limitations Missing From Petal

- C. Claim 2
- D. Claims 3-6 and 10
- E. Summary

III. Conclusion

REMARKS

Applicants appreciate the time taken by the Examiner to review the claims under reexamination and the thoroughness of the remarks provided by the Examiner in the Office Action mailed February 7, 2005. The '035 Patent has been carefully reviewed in light of that Office Action. Based on that review and the remarks made below, Applicants respectfully request reconsideration and favorable action in this case.

I. Rejections Under 35 U.S.C. §102(b)

A. Introduction

Claims 7-9 and 11-14 are rejected under 35 U.S.C. 102(b) as being anticipated by "Petal: Distributed Virtual Disks" ("Petal").

Anticipation under § 102 requires that "each and every element as set forth in the claim is found, either expressly or inherently described in a single prior art reference." See, *Verdegaal Bros. v. Union Oil Co. of California*, 814 F.2d 628, 621, 2 USPQ2d 1051, 1053 (Fed. Cir. 1987). The identical invention must be shown and the elements must be arranged as required by the claim. See, *Richardson v. Suzuki Motor Co.* 868 F.2d 1226, 1236, 9 USPQ 2d 1913, 1920 (Fed. Cir. 1989) and *In re Bond*, 910 F.2d 831, 15 USPQ2d 1566 (Fed. Cir. 1990). See also, MPEP 2131. However, a reference must be enabling to be anticipatory. See, *Amgen, Inc. v. Hoechst Marion Roussel, Inc.*, 314 F.3d 1313, 1354, 65 USPQ2d 1385, 1416 (Fed. Cir. 2003) ("A claimed invention cannot be anticipated by a prior art reference if the allegedly anticipatory disclosures cited as prior art are not enabled").

As detailed more fully below, Applicants respectfully submit that neither independent Claim 7 nor independent Claim 11 is anticipated (or rendered obvious) by Petal, as Petal does not disclose, teach or suggest certain limitations of these claims, including: i) allowing devices (e.g., workstations) connected to a first data transport medium to access storage devices using native low level block protocols, ii) mapping between devices (e.g., workstations) connected to the first transport medium and the storage devices and iii) implementing access controls.

B. Claims 11-14

The Examiner devoted a large portion of the Office Action to Claim 11. Accordingly, Applicants will first show how Claim 11 differs from the Petal reference cited by the Examiner, and then address the other Claims.

1. Overview of Claim 11

Claim 11 recites:

A method for providing virtual local storage on remote storage devices connected to one transport medium to devices connected to another transport medium, comprising:
interfacing with a first transport medium;
interfacing with a second transport medium;
mapping between devices connected to the first transport medium and the storage devices and that implements access controls for storage space on the storage devices; and allowing access from devices connected to the first transport medium to the storage devices using native low level block protocols. [emphasis added].

Claim 11 includes the limitations of (i) “mapping between devices connected to a first transport medium and storage devices”, (ii) “implement[ing] access controls” and (iii) “allowing access from devices connected to the first transport medium to the storage devices using native low level block protocols”. These features of the present invention allow a host (e.g., workstation) connected to the first transport medium (e.g., Fibre Channel (FC)) to access only that portion (or portions) of the storage devices associated with that particular host. These features also allow a host (or hosts) to communicate with storage devices using only native low level block protocols (“NLLBPs”).

2. Petal Does Not Disclose “Allowing Access” From A Workstation Using NLLBP

Claim 11, as discussed above, recites “allowing access from devices connected to the first transport medium to the storage device using native low level block protocols.” The “devices connected to the first transport medium” may comprise computer workstations in one exemplary embodiment of the present invention. A NLLBP is a protocol that enables workstations and network servers to exchange information with storage devices without the overhead of high-level protocols and file systems typically required by network servers. As explained below, this definition for NLLBP is supported by both the Specification of the '035 Patent, and the judicial interpretation of a similar limitation by Judge Sparks of the U.S. District Court for the Western District of Texas (an interpretation upheld on appeal by the Court of Appeals for the Federal Circuit).

In systems prior to the present invention, when a computer workstation would make a storage request to a storage device (e.g., disk drive) through a network server, the workstation

first had to translate the request from its file system protocols to higher level network protocols to communicate with the network server. The network server then would translate these high level protocols into low level requests to the storage device(s). See '035 Patent Specification, col. 1, lines 50-60 and col. 3, lines 14-15 (distinguishing an NLLBP from higher-level protocols by contrasting the present invention to prior art solutions). This high level to low level translation wastes valuable time and makes the access of information occur at a much slower rate. See '035 Patent Specification, col. 1, lines 50-60.

Further, in *Crossroads v. Chaparral Network Storage, Inc.*, Western District of Texas, Civil Action No. A-00-CA-217-SS and *Crossroads Systems (Texas), Inc., v. Pathlight Technology, Inc.*, Western District of Texas, Civil Action No. A-00CA-248-JN (collectively, the "Chaparral Litigation"), the U.S. District Court for the Western District of Texas issued a Joint Markman Order (the "Markman Order") interpreting the term NLLBP for the purposes of United States Patent No. 5,941,972 (the "'972 Patent"), the parent of the '035 Patent, as follows:

a set of rules or standards that enable computers to exchange information and do not involve the overhead of high level protocols and file systems typically required by network servers.

A copy of the Markman Order is attached hereto as Exhibit A. This construction, and the validity of the '972 Patent, was upheld by the Federal Circuit on appeal. A copy of the Federal Circuit decision affirming the decision of the lower court is attached hereto as Exhibit B. Thus, based on the Markman Order, an NLLBP is a protocol that enables computers to exchange information without the overhead of high-level protocols and file systems typically required by network servers.

As discussed in the '035 Patent, allowing access from host devices (e.g., workstations) to storage devices is done using NLLBPs in the present invention. Using the example of a first transport medium of Fibre Channel ("FC") and second transport medium of Small Computer System Interface ("SCSI"), a FC-connected workstation can communicate low level SCSI commands directly to a storage device using NLLBPs. For this example, the present invention accomplishes this by encapsulating the low level SCSI commands in an FC 'wrapper' or 'layer.' The specification of the '035 Patent discusses an exemplary embodiment where a Fibre Channel attached initiator (e.g., a workstation) issues SCSI-3 FCP commands, and an associated SCSI target storage device operates on a SCSI-2 protocol (See '753, col. 6, lines 33-45). In this case, a storage router connected between the host device and the storage device receives the FC-encapsulated low level SCSI commands, removes the FC

encapsulation, and forwards the low level SCSI commands to the storage devices (provided the workstation is allowed to have such access, as will be discussed more fully below). In this example, there is no translation of the commands from a higher level protocol to a low level protocol. In other words, the storage router is not required to translate some high level command from the workstation (e.g., a file system command, or function call with arguments) into a low level SCSI command. Rather, the storage router simply strips the FC 'layer' off of the existing SCSI command, and forwards the SCSI command to the storage device without any high-to-low level translation (because no such high level to low level translation is needed). Thus, when a host workstation is allowed to have access to a storage device, that access is accomplished using only NLLBPs.

Petal, on the other hand, discloses a system in which Petal clients (i.e., workstations) send higher-level protocol commands to the Petal Server that, in turn, transforms these higher-level, higher overhead commands into low-level SCSI commands that are forwarded to the storage devices (i.e., at least one high level to low level translation takes place between the workstation and the storage device). Petal clients are configured with a Petal device driver in the kernel layer of the Petal client. See, *Petal* page 88, col. 2, section 3. Higher level applications (i.e., user space applications) see virtual disks (representations of the storage devices) through the Unix File System. See *Petal*, page 90, col. 1, section 3.2. When a Petal client wishes to access a storage device behind the Petal server, the client issues a file system command to the virtual disk which is passed through the class layer to the Petal device driver (i.e., the kernel layer process for accessing the virtual disk). The Petal device driver then issues a remote procedure call ("RPC") using the User Datagram Protocol ("UDP") to the Petal server to read or write data. See, *Id* at page 88, col. 2, section 3 (describing the RPC interface) and page 89, col. 1, section 3.1 (describing handling read and write requests). The Petal device driver acts as a filter driver to translate the command to the virtual disk seen by the user space application into an RPC that is sent out in UDP packets.

An RPC is a well known mechanism in networked operating systems and is essentially a function call to the Petal Server. In issuing an RPC, a client will provide a server with the appropriate arguments in a UDP packet so that the server can perform some process. The Petal Server performs a transformation when receiving the RPC in the UDP packet by processing the RPC in the UDP packet to execute the called process and generate the appropriate low level SCSI READ and WRITE commands. Thus, the Petal client uses the traditional network mechanism of issuing a higher level command (e.g., an RPC in a UDP

packet) to the network server that the network server processes to call a function. The Petal server must execute the appropriate function to transform the information in the UDP packets to the appropriate low level SCSI command.

Thus, the Petal system does not allow the client (i.e., workstation) to access the storage devices using an NLLBP. Instead, the Petal client uses a scheme in which high level file system commands to virtual disks are translated into RPCs which are packaged in UDP packets and transported to the Petal server for transformation into low level commands. Unlike the NLLBP commands described and claimed in the '035 Patent, these RPC in UDP packets contain additional higher level overhead and require transformation to low level SCSI commands at the Petal Server. As noted above, the Petal server executes the called procedure to translate the RPC in UDP to the appropriate low level SCSI command.

The process of Petal therefore requires first creating an RPC, and then encapsulating the RPC in UDP at the Petal client, and further executing a procedure to transform the RPC in UDP to a low level SCSI command. Consequently, while the Examiner has pointed out various portions of Petal that discuss using block-level (i.e., low level) storage protocols (e.g., SCSI commands), it is only in the context of the time period after high level RPCs have been transformed to low level SCSI commands. The system of Petal is the type of system that the present invention was designed to overcome, because the system of Petal does involve the overhead of high level protocols (i.e., RPCs) typically required by network servers (i.e., RPCs), and requires a transformation of the high level protocols into low level SCSI commands at the Petal server.

Therefore, Petal does not disclose, teach or suggest a system for "allowing access from devices connected to the first transport medium to the storage devices using native low level, block protocols," as recited in independent Claim 11.

3. Petal Does Not Disclose "Mapping Between Devices Connected To The First Transport Medium And The Storage Devices"

Claim 11 also recites "mapping between devices connected to the first transport medium and the storage devices." Mapping between devices connected to the first transport medium and storage devices in the present invention refers to a mapping between the workstations and storage devices such that a particular workstation on the first transport medium is associated with a storage device, storage devices, or portions thereof, on the second transport medium. As discussed in the '035 Patent Specification, the mapping provides a correlation between

devices on the first data transport medium (e.g., workstations) and the storage devices through one or more steps. See, '035 Patent col. 1, lines 6 through col. 2, line 5 and col. 8, lines 67 – col. 9, line 5.

In the Chaparral Litigation, the U.S. District Court for the Western District of Texas adopted the definition that a “map” contains a representation of a device on one side of the storage router to a storage device on the other side (e.g., from a Fibre Channel host device to a SCSI storage device). See, Markman Order, Exhibit A, page 12. The mapping of the '035 Patent associates the host device(s) on the first transport medium (e.g., workstations) with storage devices on the second transport medium. Thus, the mapping can include mapping from a host workstation identifier (e.g., address or other identifier) to a virtual representation of a storage device (e.g., a virtual Logical Unit Number (LUN)), and potentially even further from the virtual representation of the storage device to a physical representation of the storage device (e.g., a physical LUN).

It should be expressly understood that the ‘mapping’ of the present invention is not identical to the concept of “virtualization.” In virtualization, a storage device (or portion thereof) is presented with a particular logical address to the hosts or workstations. While it is clear that the present invention can include virtualization as part of the mapping (e.g., the map can include the mapping from a virtual representation of the storage (virtual LUN) to a physical representation of the storage (physical LUN)), such virtualization is not, in and of itself, a mapping between devices on the first and second data transport media as defined in the '035 Patent. See, '035 Patent, col. 8, line 65-67. In fact, this type of virtualization was available in a number of RAID systems at the time Petal was written. Virtualization does not require that representations of workstations on one side of the storage router be mapped to a storage device(s) on the other side of the storage router.

Petal does not disclose, teach or suggest a map that maps between devices connected to the first transport medium (e.g., workstations) and storage devices connected to the second transport medium as recited in Claim 11 of the '035 Patent. In Petal there is simply no map that associates host devices (i.e., the Petal clients) with the storage devices or representations of the storage devices. At best, Petal teaches “virtualization” of storage devices. In other words, Petal discusses a virtual to physical mapping of the storage devices rather than a mapping from the device making a request (e.g., workstation) to the storage device for which the request is intended. Petal states:

The basic problem is to translate virtual addresses of the form <virtual-disk-identifier, offset> to physical addresses of the form <server-identifier, disk-identifier, disk-offset>.

See Petal, page 85-86, sections 2.1-2.3 and Figure 4 (entitled "Virtual to Physical Mapping").

In Petal, a virtual disk directory of virtual disks is mapped to a global directory which is mapped to physical disks. *Id.* A client workstation provides a virtual disk identity which is translated into a global map identifier. *Id.* The global map determines the server responsible for translating the given offset. *Id.* The physical map of the specified server translates the global map identifier and offset to a physical disk and an offset within that disk. See *Id.*, page 86, col. 1, section 2.1. Thus, the mapping of Petal only represents the virtualization mapping of storage devices and does not correlate or associate the storage devices (either virtual or physical) to particular Petal clients (e.g., workstations) on the other side of the Petal server. In fact, the virtualization-type mapping described in Petal is simply a description of the virtualization technique generally used in RAID systems at the time of Petal.

The Examiner correctly points out that, in Petal, a disk identifier used by clients to reference a particular virtual disk is "mapped" to a physical identifier. However, this is simply virtualization-type mapping. There is no correspondence (or map) made from the Petal clients to the storage devices (or portions thereof) behind the Petal Server. Put another way, there is no mechanism disclosed in Petal to perform the function of mapping a particular client workstation to a particular storage device (or portion). Consequently, Petal teaches a virtualization scheme, not a "mapping between devices connected to the first transport medium and storage devices" as recited in Claim 11 of the '035 Patent.

4. Petal Does Not Disclose Implementing "Access Controls"

a. Implementing Access Controls Requires Allowing Access Using

NLLBPs

Claim 11 recites "implementing access controls" which requires allowing access using NLLBPs. As described in the '035 Patent, "access controls" are a particular form of security measure designed to prevent unauthorized access to particular storage devices or portions of storage devices by certain workstations. When "access controls" are implemented, particular workstations may be permitted access to particular storage devices or subsets of storage devices. See, e.g., FIGURE 3 of the '035 Patent (permitting access from particular workstations to undivided storage devices as well as divided subsections within a single storage

device). According to the previously mentioned Markman Order, “access controls” means “providing controls which limit a computer’s access to specific subset of storage devices or sections of a single storage device.” See, Markman Order, Exhibit A, page 6.

The “access controls” of the ‘035 Patent allow access using a NLLBP such that requests from devices connected to the first transport medium (e.g., workstations) are directed to assigned virtual local storage on the storage devices. See, col. 8, lines 61-65. The ‘035 Patent recites:

The router can...map, for each initiator, what storage access is available and what partition is being addressed by a particular request. In this manner, the storage space provided by [storage devices] can be allocated to [devices connected to the first transport medium] to provide virtual local storage...

See ‘035 Patent, col. 8, lines 67 – col. 9, line 5.

Thus, the “access controls” described in the ‘035 Patent are device-centric in that they permit or deny access from particular devices connected to the first data transport medium (e.g., workstations) to particular storage devices (or subsets thereof) according to the map. The access controls are thus part of the configuration for routing commands from a device connected to the first transport medium to *defined* storage location(s) using NLLBPs (i.e., without requiring the overhead of high level protocols typically required by network servers) according to the map.

b. Petal Is Not an Anticipatory Reference Because Petal Does Not Enable Access Controls

In rejecting the limitation of “implementing access controls” the Examiner points to Petal, page 90, col. 2, section 4, which states in pertinent part:

...currently we do not provide any special support for protecting a client’s data from other clients; however, it would not be difficult to provide security on a per virtual disk basis.

Applicants submit, however, that the statement “it would not be difficult to provide security on a per virtual disk basis,” without more, does not enable security on per virtual disk basis in the UDP environment of Petal. UDP is primarily a broadcast protocol in which the computer issuing a UDP communication typically places UDP packets on a network without regard to the device that receives the packets.

Petal provides no support as to how to implement its “security on a per virtual disk basis” for UDP broadcast packets communicated over an ATM transport medium. For example, a common security method in packet based networks is the use of access control lists (“ACLs”). While ACLs may be used to entirely block UDP communications (e.g., as in a firewall), Petal provides no suggestions on how to implement ACLs in a UDP environment to limit access to a portion of a server file system (e.g., a particular virtual disk). As Petal provides no support for providing security in the UDP/ATM environment, Applicants respectfully submit that Petal does not enable security and therefore cannot anticipate the limitation of “access controls” recited in Claim 11.

c. There Is No Disclosure or Teaching In Petal That The ‘Security’ Referenced Therein Would Allow Access Using NLLBP

Even though the Petal article states that “it would not be difficult to provide security on a per virtual disk basis” there is no teaching or suggestion as to how such security would be provided. Certainly, there is no teaching or suggestion in Petal that a ‘security’ feature could be implemented to allow access using an NLLBP. It simply is unclear what type or manner of ‘security’ Petal references. For example, security can be a simple password-based security scheme, or something much more complex.

Moreover, even if security were implemented in Petal, there is no teaching or suggestion that such security would be implemented to allow access using a NLLBP. It would appear that any security implemented would be on top of the high level RPC over UDP scheme of Petal. Again, this would appear to require the high-level protocols and would not provide access using an NLLBP. Thus, even if security were applied to the system of Petal, this does not suggest access controls that allow access using an NLLBP.

d. Petal Does Not Render The Access Controls Limitation Of Claim 11 Obvious

Applicants note that that a non-enabling reference may qualify as prior art for the purpose of obviousness under 35 U.S.C. §103. See, *Symbol Technologies, Inc. v. Opticon*, 935 F.2d. 1569, 1578 (Fed. Cir. 1991) (“while a reference must enable someone to practice the invention in order to anticipate under §102(b), a non-enabling reference may qualify as prior art for the purpose of determining obviousness under §103(a)”). However, even if the rejection of “implementing access controls” is read as an obviousness type rejection under 35 U.S.C. §103,

Applicants assert that the rejection must fail because Petal, at best, only makes it 'obvious to try' some unspecified form of security.

"An 'obvious-to-try' situation exists when a general disclosure may pique the scientist's curiosity, such that further investigation might be done as the result of the disclosure, but the disclosure itself does not contain a sufficient teaching of how to obtain the desired result, or that the claimed result would be obtained if certain direction were followed." *In re Eli Lilly & Company*, 902 F.2d 943, 945, 14 USPQ.2d 1741 (Fed Cir. 1990). "Obvious-to-try", however, is not the standard for obviousness under §103. See, *In Re O'Farrell*, 853 F.2d 894, 902, 7 USPQ.2d 1673 (Fed. Cir. 1988). For example, the statement in a patent that "the user of the external field canceling method . . . can allow for gradient fields to be produced with greatly reduced problems" provided only general guidance as to the form of the claimed invention and how to achieve it but did not provide sufficient guidance to render the claimed invention obvious. See, *In Re Roemer*, 258 F.3d, 1303, 1309-10, 59 USPQ.2d 1527 (Fed. Cir. 2001). Similarly, the Petal reference does not provide sufficient guidance as to what is meant by "security" or how to implement such a "security" feature; and certainly does not provide any guidance on how to implement "access controls" as recited in Claim 11 of the '035 Patent.

At best, the statement in Petal that "currently we do not provide any special support for protecting a client's data from other clients; however, it would not be difficult to provide security on a per virtual disk basis" is an invitation-to-try to implement some unspecified security feature on a per virtual disk basis. The statement does not provide any teaching or suggestion as to how the security feature would be achieved, much less how "access controls" to allow access using NLLBPs would be achieved. Thus, while it may be 'obvious-to-try' some unspecified security feature based on the above-cited statement, one is left completely in the dark as to how such security would be achieved.

Moreover, the Examiner has not pointed to any art or other evidence in the record such that one of ordinary skill in the art would have a reasonable expectation of success in implementing the claimed "access controls" to allow access using an NLLBP in a UDP/ATM environment to limit access to a particular virtual disk. If the Examiner is relying on his own knowledge that one of skill in the art would know how to implement "access controls" to allow access using an NLLBP on a per virtual disk basis in the Petal environment, then Applicants respectfully request that the Examiner provide an affidavit detailing the data on which the Examiner relies for this position, or alternatively allow Claim 11. See 37 CFR 1.107(b) and MPEP 707.05.

5. Claim 12

Claim 12 depends from Claim 11 and recites that “the mapping between devices connected to the first transport medium and the storage devices includes allocating subsets of storage space to associated devices connected to the first transport medium, wherein each subset is only accessible by the associated device connected to the first transport medium.”

Thus, in Claim 12, hosts on the first transport medium are allocated storage devices (or subsets of storage devices) in the mapping such that the allocated storage only is accessible by those associated hosts on the first transport medium. In other words, storage is allocated to specific hosts on the first transport medium. This is supported by the Markman Order in which the court adopted the construction that “allocation of subsets of storage space to associated Fibre Channel devices, wherein each subset is only accessible by the associated Fibre Channel device” means that subsets of storage are allocated to specific fibre channel devices for purposes of the ‘972 Patent. See, Markman Order, Exhibit A, pages 6-7.

As discussed above in more detail, the mapping of Petal does not allocate storage to particular Petal clients, but simply provides a mapping between a virtual disk identification and physical disk identification. Consequently, Petal does not anticipate Claim 12.

6. Summary

In sum, Petal fails to teach: (1) “allowing access from devices connected to the first transport medium to the storage device using native low level block protocols,” (2) “mapping between devices connected to the first transport medium and the storage devices” and (3) “implementing access controls.”

Instead, Petal teaches a system in which high level RPC calls in UDP packets must be transformed into low-level SCSI commands by the Petal server. Further, there is no disclosure, teaching or suggestion in Petal that clients on one side of the Petal server should be mapped to storage devices on the other side of the Petal server. Moreover, access controls to allow access using NLLBPs are not disclosed, taught or suggested in Petal nor is any other security method. At most, Petal suggests that it would be ‘obvious-to-try’ adding an undefined security measure, without providing any direction as to how to do so with a reasonable expectation of success. Therefore, Applicants submit that Petal does not anticipate (or render obvious) the

present invention as recited in Claim 11, and respectfully requests allowance of such claim. Applicants also respectfully request allowance of Claims 12-14 as representing further limitations on Claim 11.

C. Claims 7-10

Applicants respectfully submit that independent Claim 7 is distinguishable from Petal for similar reasons as discussed above with reference to Claim 11, as well as additional reasons. For completeness, the Applicants will review the differences discussed above with respect to Claim 11, but for the sake of brevity will summarize the explanations of these differences rather than repeating entire arguments already presented.

1. Overview of Claim 7

Claim 7 recites:

A storage network, comprising:
a first transport medium;
a second transport medium;
a plurality of workstations connected to the first transport medium;
a plurality of storage devices connected to the second transport medium; and
a storage router interfacing between the first transport medium and the second transport medium, the storage router providing virtual local storage on the storage devices to the workstations and operable:
to map between the workstations and the storage devices;
to implement access controls for storage space on the storage devices; and
to allow access from the workstations to the storage devices using native low level, block protocol in accordance with the mapping and access controls.

Claim 7, thus, specifies a "storage router" that maps between workstations and storage devices, implements access controls and allows access from workstations to the storage devices using NLLBP in accordance with the mapping and access controls. As with Claim 11, Applicants submit that the system of Petal does not disclose, teach or suggest i) "allow[ing] access from the workstations to the storage devices" using NLLBP, ii) "map[ping] between the workstations and the storage devices, and iii) "implement[ing] access controls".

2. Petal Does Not Disclose “Allow[ing] Access” From A Workstation Using NLLBP

The present invention, in accordance with Claim 7, allows workstations to access storage devices using a NLLBP. A NLLBP, as discussed above, is a set of rules or standards that enable computers to exchange information and do not involve the overhead of high level protocols and file systems typically required by network servers. Thus, the workstations described in Claim 7 can access the claimed storage devices using low level NLLBP commands which have not been translated from high level commands.

Petal, on the other hand, teaches a system in which a Petal client issues high level commands as RPCs in UDP packets, where the RPC calls a function of the Petal server Unix operating system. The Petal server must transform the high level RPC in UDP into a low level SCSI command by implementing the called procedure to generate the appropriate SCSI command(s). Petal, thus, uses a traditional RPC scheme that involves the overhead of high level protocols typically required by traditional network servers. Consequently, the Petal server does not allow the Petal clients to access the storage devices using an NLLBP.

3. Petal Does Not Disclose a “Map” Between Workstations And Storage Devices

The storage router of Claim 7 maps between workstations connected to the first transport medium on one side of the storage router and the storage devices located on the other side of the storage router. This mapping is more than mere virtualization as the storage router associates workstations with particular storage devices or subsets of storage devices.

Petal does not disclose, teach or suggest a map that associates particular devices connected to the first transport medium with particular storage devices (or subsets thereof). Rather, Petal teaches that a virtual to physical mapping (i.e., virtualization of the storage device) takes place. There is, however, no correspondence made between the clients and storage devices (or portions thereof) in the mapping of Petal; i.e., there is no mechanism disclosed to say “this client maps to that storage device” on the other side of the Petal server. Consequently, Petal teaches a virtualization scheme not a “mapping” between workstations and storage devices.

4. Petal Does Not Provide Access Through "Access Controls"

As discussed above with respect to Claim 11, the sole statement in Petal relevant to access controls is "currently we do not provide any special support for protecting a client's data from other clients; however, it would not be difficult to provide security on a per virtual disk basis," does not in fact disclose or teach "access controls" in any anticipatory manner. This statement provides, at best, a suggestion that it is 'obvious-to-try' an undefined security measure in the UDP/ATM system of Petal. Applicants therefore submit that Petal does not disclose, teach or suggest a supervisor unit that implements "access controls."

5. Claim 8

Claim 8 depends from Claim 7 and recites that the access controls "include an allocation of subsets of storage space to associated workstations, wherein each subset is only accessible by the associated workstation." Thus, the claimed access controls allocate subsets of storage to particular workstations. Applicants respectfully submit that Petal does not teach this feature of Claim 8 as Petal does not describe or suggest allocating storage or subsets of storage to particular clients.

6. Summary

Petal fails to disclose, teach or suggest a storage router which performs the functions of i) "allow[ing] access from the workstations to the storage devices" using NLLBP, ii) "map[ping] between the workstations and the storage devices, and iii) "implement[ing] access controls."

Instead, Petal teaches a Petal server that transforms higher level RPC calls in UDP packets to generate low-level SCSI commands for communicating with storage devices. Also, there is no disclosure, teaching or suggestion that the Petal server should map clients on one side of the Petal server to storage devices on the other side of the Petal server. Moreover, Petal does not disclose or suggest providing "access controls" as claimed, nor any other security method. At most, it is suggested that it would be 'obvious-to-try' adding security without providing any direction as to how to do so with a reasonable expectation of success. Therefore, Applicants submit that Petal does not anticipate or render obvious the present invention as recited in Claim 7, and respectfully requests allowance of Claim 7. Applicants also respectfully request allowance of Claims 8-10 as representing further limitations on Claim 7.

II. Rejections Under 35 U.S.C. §103

A. Introduction

Claims 1-6 and 10 are rejected under 35 U.S.C. §103(a) as being unpatentable over Petal in view of Quam, Cummings, Crouse et al., and Pisello et al.

As discussed above, with reference to independent Claims 7 and 11, Petal fails to disclose, teach or suggest i) “allow[ing] access from the workstations to the storage devices” using NLLBP, ii) “map[ping] between the workstations and the storage devices, and iii) “implement[ing] access controls.”

In order to establish a *prima facie* case of obviousness, the Examiner must show: that (1) the prior art references teach or suggest all of the claim limitations, (2) that there is some suggestion or motivation in the references (or within the knowledge of one of ordinary skill in the art) to modify or combine the references and (3) that there is a reasonable expectation of success. M.P.E.P. 2142, 2143; *In re Vaeck*, 947 F.2d 488, 20 U.S.P.Q.2d 1438 (Fed. Cir. 1991). The Examiner must explain with reasonable specificity at least one rejection – otherwise, the Examiner has failed procedurally to establish a *prima facie* case of obviousness. M.P.E.P. 2142; *Ex parte Blanc*, 13 U.S.P.Q.2d 1383 (Bd. Pat. Application. & Inter. 1989). When the motivation to combine the teachings of the references is not immediately apparent, it is the duty of the Examiner to explain why the combination of the teachings is proper. *Ex parte Skinner*, 2 U.S.P.Q.2d 1788, 1790 (Bd. Pat. App. & Inter. 1986).

Applicants respectfully submit that the Examiner has failed to establish a *prima facie* case of obviousness as the references do not disclose, teach or suggest all of the claim limitations of Claims 1-6 and 10. More particularly, the references do not disclose, teach or suggest a “supervisor unit” operable to i) “map between devices connected to the first transport medium and the storage devices,” ii) “implement access controls for the storage space on the storage devices” and iii) “allow access from devices connected to the first transport medium to the storage devices using a NLLBP.” Furthermore, Applicants submit that one of ordinary skill in the art would not be motivated to combine Petal with Quam, Cummings, Crouse or Pisello.

B. Claim 1

In rejecting Claim 1, the Examiner relies on the previously discussed rejections under 35 U.S.C. §102(b) to identify where various features of Claim 1 are found in the Petal reference. Applicants respectfully submit, however, that several of the features of Claim 1 which are

rejected under Petal are not disclosed, taught or suggested by the reference, as discussed above with respect to Claims 7 and 11. Again, for the sake of brevity the Applicants will summarize the previously presented arguments rather than repeating them in their entirety.

1. Overview of Claim 1

Claim 1 recites:

A storage router for providing virtual local storage on remote storage devices to devices, comprising:
a buffer providing memory work space for the storage router;
a first controller operable to connect to and interface with a first transport medium;
a second controller operable to connect to and interface with a second transport medium; and
a supervisor unit coupled to the first controller, the second controller and the buffer, the supervisor unit operable to map between devices connected to the first transport medium and the storage devices, to implement access controls for storage space on the storage devices and to process data in the buffer to interface between the first controller and the second controller to allow access from devices connected to the first transport medium to the storage devices using native low level, block protocols.

Thus, Claim 1 recites a “storage router” with a “supervisor unit” operable to i) “map between devices connected to the first transport medium and the storage devices,” ii) “implement access controls for storage space on the storage devices,” and iii) “allow access from devices connected to the first transport medium the storage devices using NLLBP.” As discussed above, these claimed features of the present invention allow each host connected to the first transport medium to access some portion of storage on the storage devices associated with that host using an NLLBP.

2. Petal Does Not Disclose “Allow[ing] Access” From A Workstation Using NLLBP

The present invention, in accordance with Claim 1, allows workstations (or other host devices) to access storage devices using an NLLBP. An NLLBP, as discussed above is a set of rules or standards that enable computers to exchange information and do not involve the overhead of high level protocols and file systems typically required by network servers. Thus, the devices of Claim 1 connected to the first data transport protocol can access the storage devices using commands that do not require translation from a high level protocol to a low-level protocol.

The Examiner again relies on Petal for the rejection of this limitation of Claim 1. Petal, however, teaches a system in which a Petal client issues high level commands as an RPC in UDP packets. The RPC subsequently calls a function of the Petal server Unix operating system. The Petal server must then transform the RPC in UDP to generate the appropriate SCSI READ/WRITE commands. Thus, Petal uses a traditional RPC scheme that, like the prior art systems the invention of the '035 Patent was designed to overcome, involves the overhead of high level protocols typically used by traditional network servers. Consequently, the Petal server does not allow the Petal clients to access the storage devices using an NLLBP. Thus, Petal does not (and cannot) show a "supervisor unit" operable to "allow access from devices connected to the first transport medium the storage devices" using NLLBPs.

Moreover, the Examiner does not particularly point out where this feature of the present invention can be found in the other references. Therefore, Applicants respectfully request that the Examiner allow Claim 1.

3. Petal Does Not Disclose a "Map" Between Devices On The First Transport Medium and Storage Devices

The "supervisor unit" of Claim 1 maps between devices located on one side of the storage router and the storage devices located on the other side of the storage router. This mapping is more than mere virtualization as the supervisor unit associates workstations or other devices on one side of the storage router with particular storage devices.

The Examiner again relies on Petal in rejecting this limitation of Claim 1. Applicants respectfully submit, however, that Petal does not disclose, teach or suggest a unit that maps between devices connected to the first transport medium and storage devices connected to the second transport medium. Rather, Petal teaches that a virtual to physical mapping of the storage itself (i.e., virtualization of the storage devices). There is no association made between the clients and storage devices (or portions thereof) in the mapping of Petal. In other words, there is no mechanism disclosed to say "this client device maps to that storage device" on the other side of the Petal server). Consequently, Petal teaches a virtualization scheme, not a mapping between workstations and storage devices.

Applicants further submit that Examiner has not pointed out where this feature of the present invention can be found in the other references and therefore has not made out a *prima facie* case of obviousness. Therefore, Applicants respectfully request withdrawal of the rejection and allowance of Claim 1.

4. Petal Does Not Disclose, Teach or Suggest The “Access Controls” Limitation Of Claim 1

As discussed above, the statement in Petal that “currently we do not provide any special support for protecting a client’s data from other clients; however, it would not be difficult to provide security on a per virtual disk basis” is, at best, an ‘invitation to try’ to a security feature, and not necessarily providing “access controls” to allow access using NLLBPs on a per virtual disk basis. The statement does not by itself provide any teaching or suggestion as to how the “access controls” recited in Claim 1 can be achieved.

Thus, while it may have been ‘obvious-to-try’ a security feature based on the above-cited statement, one of ordinary skill in the art is left completely in the dark as to how such security feature would be achieved, much less how one would achieve “access controls” using NLLBPs as recited in Claim 1. As the cited case law points out, an invitation to try a feature is not enough in an of itself to render a claimed invention obvious.

Moreover, the Examiner has not pointed to any art or other evidence on the record such that one of skill in the art would have a reasonable expectation of success in implementing access controls for a UDP/ATM environment.

5. There Is No Showing That The Remainder Of The References Contain The Limitations Missing From Petal

The Examiner relies on Quam, Cummings, Crouse and Pisello in rejecting protocol and hardware specific features of the claimed invention. Applicants note, however, that the Examiner has not pointed out where these cited references make up for the deficiencies of Petal with respect to allowing access from a device connected to the first transport media to a storage device using a NLLBP, mapping, and access controls. As these features are not disclosed or taught in Petal, as discussed above, and are not pointed to in the other references, the burden of making out a *prima facie* case of obviousness has not been met. Therefore, Applicants respectfully request allowance of Claim 1.

C. Claim 2

Applicants respectfully submit that Claim 2 depends from Claim 1 and represents further limitations thereon. With respect to Claim 2, the claim recites that the “supervisor unit” “maintains and allocation of subsets of storage space to associated devices connected to the

first transport medium, wherein each subset is only accessible by the associated device connected to the first transport medium.” As discussed above in conjunction with Claims 8 and 12, the access controls allocate subsets of storage to particular devices on the first transport medium (e.g., workstations). Applicants respectfully submit that Petal does not disclose, teach or suggest this feature of Claim 2 as Petal does not describe or suggest allocating storage devices or subsets of storage devices to particular clients. Therefore, Applicants respectfully request allowance of Claim 2.

D. Claims 3-6 and 10

Applicants respectfully submit that Claims 3-6 and 10 depend directly or indirectly from Claims 1 and 7, respectively. Therefore, Applicants respectfully request allowance of these claims as representing further limitations on the respective independent claims and any intervening claims.

E. Summary: There is No *Prima Facie* Showing of Obviousness

Applicants respectfully submit that the Examiner has failed to establish a *prima facie* case of obviousness for Claims 1-6 and 10 as the prior art references do not disclose, teach or suggest all of the claim limitations. Specifically, the prior art cited by the Examiner does not appear to teach a “supervisor unit” that is operable to i) “map between devices connected to the first transport medium and the storage devices,” ii) to “implement access controls for the storage space on the storage devices” and iii) to “allow access from devices connected to the first transport medium to the storage devices using a NLLBP.” While the Examiner has provided a detailed discussion of Petal to attempt to show where these features are found, Applicants respectfully submit that Petal does not disclose or teach the claimed limitations, as discussed above in relation to the § 102 rejections. Furthermore, the remaining cited references (Quam, Cummings, Crouse and Pisello) do not make up for the deficiencies in Petal. Accordingly, Applicants respectfully request allowance of Claims 1-6 and 10.

III. Conclusion

Applicants appreciate the Examiner’s diligence in issuing thorough office actions in multiple reexamination cases so quickly. Applicants respectfully submit, however, that Claims 7-9 and 11-14 are distinguishable from the prior art Petal reference, and that Claims 1-6 and 10

are distinguishable from the Petal, Quam, Cummings, Crouse and Pisello references. Therefore, Applicants respectfully request allowance of all claims subject to reexamination.

Applicant has now made an earnest attempt to place this case in condition for allowance. Other than as explicitly set forth above, this reply does not include an acquiescence to statements, assertions, assumptions, conclusions, or any combination thereof in the Office Action.

For the foregoing reasons and for other reasons clearly apparent, Applicant respectfully requests full allowance of Claims 1-14. The Examiner is encouraged to telephone the undersigned at the number listed below for any questions or issues that arise during this procedure, and specifically for discussion and/or prompt action in the event any issues remain.

This Reply was served via First Class Mail on April 6, 2005 to Larry E. Severin, Wang, Hartmann & Gibbs, PC, 1301 Dove Street #1050, Newport Beach, CA 92660 and William A. Blake, Jones, Tullar & Cooper, PC, P.O. Box 2226 EADS Station, Alexandria, VA 22202.

The Director of the U.S. Patent and Trademark Office is hereby authorized to charge any fees or credit any overpayments to Deposit Account No. 50-3183 of Sprinkle IP Law Group.

Respectfully submitted,

Sprinkle IP Law Group
Attorneys for Applicant

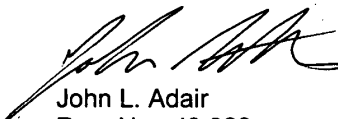

John L. Adair
Reg. No. 48,828

Date: **April 6, 2005**

1301 W. 25th Street, Suite 408
Austin, TX 78705
Tel. (512) 637-9223
Fax. (512) 371-9088

SS RECEIVED

MAR 10 2003

CLERK, U.S. DISTRICT COURT
WESTERN DISTRICT OF TEXAS
BY [Signature]
DEPUTY CLERK

NOTE: Pursuant to Fed. Cir. R. 47.6, this disposition is not citable as precedent. It is a public record. This disposition will appear in tables published periodically.

United States Court of Appeals for the Federal Circuit

02-1158

FILED

MAR 10 2003

CLERK, U.S. DISTRICT COURT
WESTERN DISTRICT OF TEXAS
BY [Signature]
DEPUTY CLERK

CROSSROADS SYSTEMS, (TEXAS), INC.,

Plaintiff-Appellee,

v.

CHAPARRAL NETWORK STORAGE, INC.,

Defendant-Appellant.

FILED
U.S. COURT OF APPEALS FOR
THE FEDERAL CIRCUIT

FEB 12 2003

JUDGMENT

JAN HORBALY
CLERK

ON APPEAL from the

United States District Court for
the Western District of Texas

In CASE NO(S).

00-CV-217 and 00-CV-621

This CAUSE having been heard and considered, it is

ORDERED and ADJUDGED: AFFIRMED. See Fed. Cir. R. 36

Per Curiam (NEWMAN, SCHALL, and DYK, Circuit Judges).

CERTIFIED COPY
I HEREBY CERTIFY THIS DOCUMENT
IS A TRUE AND CORRECT COPY
OF THE ORIGINAL ON FILE.

UNITED STATES COURT OF APPEALS
FOR THE FEDERAL CIRCUIT

By: [Signature] Date: 3/5/03

ENTERED BY ORDER OF THE COURT

DATED: FEB 12 2003

[Signature]
Jan Horbaly, Clerk

ISSUED AS A MANDATE: MARCH 5, 2003

Costs Against Appellant:
Total \$97.35

186

03/17/2003 MON 12:47 PM TX/RX NO 62731

UNITED STATES DISTRICT COURT
WESTERN DISTRICT OF TEXAS
AUSTIN DIVISION

FILED

JUL 27 2000

U. S. DISTRICT COURT
BY CLERK'S OFFICE
DEPUTY

CROSSROADS SYSTEMS, (TEXAS), INC. §

vs. §

CHAPARRAL NETWORK §
STORAGE, INC. §

NO. A 00 CA 217 SS

CROSSROADS SYSTEMS, (TEXAS), INC. §

vs. §

PATHLIGHT TECHNOLOGY, INC. §

NO. A 00 CA 248 SS

ORDER

BE IT REMEMBERED that on the 25th day of July 2000 the Court, in accordance with *Markman v. Westview Instruments, Inc.*, 52 F.3d 967 (Fed. Cir. 1995), *aff'd*, 116 S. Ct. 1384 (1996), held a hearing at which the parties appeared by representation of counsel and made oral arguments on their proposed claims construction. At the hearing, the parties presented a Joint Stipulation of Claim Construction, indicating that the parties have agreed upon the definitions for seventeen terms and/or phrases in U.S. Patent No. 5,941,972 ("the '972 patent"), and that only ten terms and/or phrases in the '972 patent remain in dispute. After considering the briefs, the case file as a whole, and the applicable law, the Court enters the following opinion and order.

I. Standard for Claims Construction

The construction of claims, or the definition of the terms used in the claims, is a matter of law for the Court. When adopting a claim construction, the Court should first consider the intrinsic evidence, which includes the claims, the specification, and the prosecution history. *See Vitronics*

27

A 00473

RECEIVED

FEB 07 2005

OFFICE OF PETITIONS

Corp. v. Conceptor, Inc., 90 F.3d 1576, 1582 (Fed. Cir. 1996) (explaining that intrinsic evidence is "the most significant source of the legally operative meaning of disputed claim language"). Not surprisingly, the starting point is always "the words of the claims themselves." *Id.*; see also *Comark Communications, Inc. v. Harris Corp.*, 156 F.3d 1182, 1186 (Fed. Cir. 1998). The words of the claims are generally given their ordinary and customary meaning, unless the patentee intended to use a "special definition of the term clearly stated in the patent specification or file history." *Vitronics*, 90 F.3d at 1582. Thus, the Court must review the specification and file history to determine whether the patentee intended to use any such "special" definitions. See *id.* The specification and file history may also be consulted as general guides for claim interpretation. See *Comark*, 156 F.3d at 1186.

The specification and file history, however, are not substitutes for the plain language of the claims. The specification is not meant to describe the full scope of the patent – it includes only a written description of the invention, sufficient to enable a person skilled in the art to make and use it, as well as the invention's "best mode." See 35 U.S.C. § 112. Thus, the claims may be broader than the specification, and generally should not be confined to the examples of the invention set forth in the specification. See *Comark*, 156 F.3d at 1187 ("Although the specification may aid the court in interpreting the meaning of disputed claim language, particular embodiments and examples appearing in the specification will not generally be read into the claims."). Indeed, the Federal Circuit has repeatedly emphasized that "limitations from the specification are not to be read into the claims." *Id.* at 1186.

In addition to examining the intrinsic evidence the Court may, in its discretion, receive extrinsic evidence regarding the proper construction of the patent's terms. See *Key Pharmaceuticals*

v. Hercon Labs. Corp., 161 F.3d 709, 716 (Fed. Cir. 1998) (“[T]rial courts generally can hear expert testimony for background and education on the technology implicated by the presented claim construction issues, and trial courts have broad discretion in this regard.”). The plaintiff has provided an expert affidavit and the defendant has provided excerpts from several dictionaries as extrinsic evidence concerning the construction of the terms of the ‘972 patent.

II. “implements access controls for storage space on the SCSI storage devices”

This phrase is used in claims 1, 10 and 11 of the ‘972 patent. The parties dispute whether the phrase refers to “access controls” only for certain subsections of a divided SCSI storage device, or whether it also includes limiting access to entire undivided SCSI storage devices. The plaintiff argues the phrase includes both kinds of access controls; the defendants say the phrase refers only to access controls for various subsections within a single divided SCSI storage device. The defendants also argue the plaintiff’s construction is improper because, if adopted, it will result in the ‘972 patent being invalidated by prior art.

The plaintiff proposes the following definition: “provides controls which limit a computer’s access to a specific subset of storage devices or sections of a single storage device.” See Plaintiff’s Brief, at 20. The defendants propose the phrase should be defined as “partitions the storage space on each one of the SCSI storage devices and defines the accessibility of each resulting partition.” See Defendants’ Brief, Ex. 2. The Court agrees with the plaintiff.

The intrinsic evidence of the ‘972 patent shows the plaintiff’s invention is intended to restrict access both to subsections of a SCSI storage device, as well as to entire, undivided SCSI devices. First, the plain language of this phrase refers only to “storage space” and does not limit the space

only to subsections of a divided SCSI storage device. Second, Figure 3 of the '972 patent supports a broad reading of this phrase. Figure 3 shows three SCSI storage devices, two of which are undivided (60 and 64). The third device (62) is divided into four subsections of storage space. From the simple labeling on Figure 3, it is clear that the entire, undivided storage device (64) is meant to be accessed only by a single workstation (computer E). Thus, Figure 3 expressly shows that the plaintiff's invention contemplates using "access controls" for an entire, undivided storage device as well as for the divided subsections within a single storage device.¹ Third, the language of the specification expressly describes limiting access to an entire, undivided SCSI storage device. Specifically, in referring to Figure 3, the specification states "storage device 64 can be allocated as storage for the remaining workstation 58 (workstation E)." See '972 Patent, at 4:20 - 4:21. At the hearing, the defendants' counsel argued that, simply because Figure 3 describes this feature does not mean the feature was intended to be part of the claimed invention. The Court soundly rejects this argument. Figure 3 is meant to be an example of how the plaintiff's claimed invention can be implemented, and the specification clearly describes this figure as illustrating one implementation of the claimed invention. Adopting the defendants' argument would ignore a fundamental principle of claims construction, oft repeated in the defendants' brief and oral arguments, that the specification is "the single best guide to the meaning of a disputed term." See *Vitronics*, 90 F.3d at 1582. Finally, the defendants correctly point out that the specification also refers to the single, undivided storage device (64) as a "partition (i.e., logical storage definition)." See '972 Patent, at 4:44 - 4:47. Rather than compel the defendants' proposed construction, however, this language supports the plaintiff's

¹ Figure 3 also discloses – and the defendants do not dispute – that the plaintiff's invention contemplates limiting access to various subsections of the divided SCSI storage device (62).

argument at the hearing that a discrete unit of storage – whether an entire SCSI storage device or a subsection within that device – can be referred to as a “partition.”²

The defendants also argue that, even if the intrinsic evidence supports the plaintiff’s proposed definition, this definition is nonetheless improper because it would cause the ‘972 patent to read directly upon prior art (and therefore be invalid). It is true that “claims should be read in a way that avoids ensnaring prior art if it is possible to do so.” *Harris Corp. v. IXYS Corp.*, 114 F.3d 1149, 1153 (Fed. Cir. 1997). However, the defendants have not shown that the prior art at issue – the Lui patent – would be “ensnared” by adopting the plaintiff’s definition. Importantly, the Lui patent was part of the prior art expressly considered by the patent examiner before granting the ‘972 patent. The patent examiner apparently did not use the Lui patent to reject a single claim in the ‘972 patent. The patent examiner also did not issue an Office Action requiring the plaintiff to distinguish its invention from the Lui patent on access control (or any other) grounds. Although the Patent Office is not the model of efficiency or thoroughness, its failure to cite the Lui patent as potentially invalidating prior art creates a strong presumption that the Lui patent does not read upon the plaintiff’s claimed invention. In addition, it does not appear to the Court that the Lui patent reads upon the ‘972 claimed invention. While the Lui patent does disclose a system of Fibre Channel computers and SCSI storage devices, *see* Defendants’ Brief, Ex. 6, at 2:53 - 2:65, the similarities end there. The Lui patent concerns an invention of “bypass circuits” used to “prevent the failure of any device” in the system. *See id.*, at Abstract. The invention of the Lui patent is not concerned with the swift transfer of information across a router, and thus does not disclose techniques for mapping,

² The Court expressly notes, however, that it is not defining the term “partition” in this order, as that term is not used in the ‘972 claim language.

implementing access controls, or a memory buffer.³ At the hearing, the defendants' counsel suggested that Figure 2 of the Lui patent discloses the claimed invention of the '972 patent.

However, Figure 2 of the Lui patent is not a part of the Lui invention; rather it is an illustration of a "conventional" network system that the Lui invention allegedly improves upon. *See id.* at 3:66. The Court rejects the defendants' argument that "conventional" network systems also read directly upon the '972 claimed invention. The patent examiner may have let one piece of prior art slip by; he or she would not have missed a "conventional" network system directly applicable to the plaintiff's claimed invention.

In sum, the Court will adopt the plaintiff's proposed definition and construe the phrase "implements access controls" in the claims of the '972 patent to mean "provides controls which limit a computer's access to a specific subset of storage devices or sections of a single storage device."

III. "allocation of subsets of storage space to associated Fibre Channel devices, wherein each subset is only accessible by the associated Fibre Channel device"

The dispute here is essentially the same as in the preceding section. This phrase is used in claims 2, 8 and 12 of the '972 patent. As it did with the "implements access controls . . ." phrase, the plaintiff argues the "allocation . . ." phrase means that specific Fibre Channel devices can be allocated storage space on subsections of a single SCSI storage device and on entire, undivided SCSI storage devices. The defendants stick to their general argument on this issue, and contend the phrase

³ The defendants argue these features are "implicitly" found in the Lui specification and in any event were disclosed in other prior art. *See Defendants' Brief*, at 12, and n.1. The Court is not persuaded that these features are "implicitly" disclosed by the Lui patent, and the other prior art briefly referenced by the defendants makes no mention of combining that prior art with the invention of the Lui patent, or vice-versa.

means storage space can only be allocated on subsections of a single divided SCSI storage device. Both parties agree this storage space, however it is defined, can only be accessed by the specified Fibre Channel device(s).

The plaintiff's proposed definition is "subsets of storage space are allocated to specific Fibre Channel devices." See Plaintiff's Brief, at 26. The defendants say the phrase should be defined to mean "one or more partitions that are only accessible by a single Fibre Channel device." See Defendants' Brief, Ex. 2. For the reasons discussed in the preceding section, the Court adopts the plaintiff's proposed construction.

IV. "supervisor unit"

This term is used in claims 1, 2 and 10 of the '972 patent. The plaintiff contends this term should be defined as "a microprocessor programmed to process data in a buffer in order to map between Fibre Channel devices and SCSI devices and which implements access controls." See Plaintiff's Brief, at 25. The defendants argue the term should be defined as "an Intel 80960RP processor" with several specific features. See Defendants' Brief, Ex. 2.

The defendants argue their construction is mandated by the means-plus-function analysis of § 112(6) of the Patent Act, because the claims of the '972 patent do not adequately describe the "supervisor unit" to be used. See Defendants' Brief, at 15-17. The plaintiff argues that § 112(6) does not apply because the term "means" is not used with the term "supervisor unit" and because the term "supervisor unit" is adequately described by other claim language in the '972 patent. See Plaintiff's *Markman* Exhibits, at 35-39.

Section 112(6) of the Patent Act provides that when a claim refers to the "means for" a

specific act, but fails to adequately describe these means, the means then must be defined by reference to the specification. See 35 U.S.C. § 112(6).⁴ If the claim language at issue does not include the term "means," there is a presumption that the § 112(6) means-plus-function analysis does not apply. See *Al-Site Corp. v. VSI Int'l, Inc.*, 174 F.3d 1308, 1318 (Fed. Cir. 1999) ("[W]hen an element of a claim does not use the term 'means,' treatment as a means-plus-function claim element is generally not appropriate."). To overcome this presumption, the party seeking to apply § 112(6) must show the claim language at issue is purely functional and that other claim language does not adequately describe the disputed term. See *id.* ("[W]hen it is apparent that the element invokes purely functional terms, without the additional recital of specific structure or material for performing that function, the claim element may be a means-plus-function element despite the lack of express means-plus-function language."). From a review of the claim language as a whole, the Court agrees with the plaintiff that the term "supervisor unit" is not purely functional, but refers instead to a device that can perform the tasks specifically listed in the claim language of the '972 patent. Specifically, claims 1, 2 and 10 of the '972 patent describe a "supervisor unit" that can: (1) maintain and map the configuration of networked Fibre Channel and SCSI storage devices; (2) include in this configuration an allocation of specific storage space to specific Fibre Channel devices; (3) implement access controls for the SCSI storage devices; and (4) process data in the storage router's buffer to allow an exchange between the Fibre Channel and SCSI storage devices. See '972 Patent,

⁴ Section 112(6) reads as follows: "An element in a claim for a combination may be expressed as a means or step for performing a specified function without the recital of structure, material, or acts in support thereof, and such claim shall be construed to cover the corresponding structure, material, or acts described in the specification and equivalents thereof." 35 U.S.C. § 112(6).

at Claims 1, 2 and 10. These are the same tasks described in the plaintiff's proposed definition. In addition, the specification expressly defines the "supervisor unit" as "a microprocessor" (a computer chip) and specifically as "a microprocessor for controlling operation of storage router 56 and to handle mapping and security access for requests between Fibre Channel 52 and SCSI bus 54." See *id.* at 5:7 - 5:10. However, neither the specification (nor the claim language) limits the '972 patent to the specific Intel computer chip referenced by the defendants. Although the defendants correctly point out that the Intel 80960 chip is the only computer chip expressly named in the '972 patent and the specification describes many features this chip, the defendants fail to note that the Intel 80960 chip is listed as only "one implementation" of the claimed invention's microprocessor. See '972 Patent, at 5:63. The defendants are attempting exactly what the Federal Circuit prohibits – to limit the claims to the preferred embodiment and examples of the specification. "This court has cautioned against limiting the claimed invention to preferred embodiments or specific examples in the specification." *Comark*, 156 F.3d at 1186 (quoting *Texas Instruments, Inc. v. United States Int'l Trade Comm'n*, 805 F.2d 1558, 1563 (Fed. Cir. 1988)). The Court will not use an example of "one implementation" in the specification to limit the plain language of the claims. Accordingly, the Court adopts the plaintiff's definition of "supervisor unit" and will construe that term as used in the claims of the '972 patent to mean "a microprocessor programmed to process data in a buffer in order to map between Fibre Channel devices and SCSI devices and which implements access controls."

V. "SCSI storage devices"

This term is used in claims 1, 4, 7, 9-11 and 14 of the '972 patent. The plaintiff argues that this term essentially needs no further definition because the term SCSI is so well-known in the industry, but proposes that the term can be further defined as "any storage device including, for

example, a tape drive, CD-ROM drive, or a hard disk drive that understands the SCSI protocol and can communicate using the SCSI protocol." See Plaintiff's Brief, at 18. The defendants argue the term should be defined as "any storage device that uses a SCSI standard and has a unique BUS:TARGET:LUN address." See Defendants' Brief, Ex. 2.

The Court agrees with the plaintiff. Essentially, the defendants contend their narrow definition should be used because it "comports with '972 specification" and its discussion of SCSI storage devices. See Defendant's Brief, at 14. However, the specification language referred to by the defendants is only one example of how the SCSI storage device addressing scheme "can" be represented. See '972 Patent, at 7:39. Again, the defendants are impermissibly trying to limit the claim language to an example given in the specification. See *Comark*, 156 F.3d at 1186-87. For the sake of extra clarity, the Court will adopt the plaintiff's proposed definition for this term.

VI. "process data in the buffer"

This phrase is used in claims 1 and 10 of the '972 patent. The plaintiff argues the phrase is adequately defined on its own and by the surrounding claim language. The defendants contend the phrase should be defined as "to manipulate data in the buffer in a manner to (a) achieve mapping between Fibre Channel and SCSI devices, and (b) apply access controls and routing functions." See Defendants' Brief, Ex. 2.

The plain language of claims 1 and 10 disclose that the supervisor unit (the microprocessor) processes data in the buffer "to interface between the Fibre Channel controller and the SCSI controller to allow access from Fibre Channel initiator devices to SCSI storage devices using the native low level, block protocol in accordance with the configuration." See '972 Patent, at Claims 1 and 10. This language adequately describes what it means to "process data in the buffer" for these

claims. Simply because the specification may use slightly different language to describe this "processing," *see id.* at 5:18 - 5:20, does not entitle the defendants to adopt the specification language over the plain language of the claims. The Court will not further define this phrase.

VII. "storage router"

This term is used in claims 1-7 and 10 of the '972 patent. The plaintiff argues the term needs no further definition for claims 1-6, and for claim 7 it should be defined as "a device which provides virtual local storage, maps, implements access controls, and allows access using native low level block protocols." *See Plaintiff's Brief*, at 27. The defendants contend the term should mean "a bridge device that connects a Fibre Channel link directly to a SCSI bus and enables the exchange of SCSI command set information between application clients on SCSI bus devices and the Fibre Channel links." *See Defendants' Brief*, Ex. 2.

The defendants do not make any argument for their proposed definition in their brief, and did not discuss the term at the July 25 hearing. In their notebook of exhibits presented at the hearing, the defendants include one page which supports their definition with a quote from the specification. *See Defendants' Markman Exhibits*, "Markman Presentation" Tab, at 22. This argument is disingenuous. The specification language quoted by the defendants is immediately followed by several sentences further defining "storage router." Indeed, the next sentence begins "Further, the storage router applies access controls . . ." *See '972 Patent*, at 5:30. The defendants' attempt to limit the term "storage router" to one of several descriptive sentences in the specification is not well-taken. In addition, the Court finds the term "storage router," as used in all claims of the '972 patent, is adequately described by the additional language of the claims, which discloses in detail the various functions and/or qualities of the storage router. The Court will not further define this term.

VIII. "map"

This term is used in claims 1, 7, 10 and 11 of the '972 patent. The plaintiff contends the term means "to create a path from a device on one side of the storage router to a device on the other side of the router, *i.e.* from a Fibre Channel device to a SCSI device (or vice-versa). A 'map' contains a representation of devices on each side of the storage router, so that when a device on one side of the storage router wants to communicate to a device on the other side of the storage router, the storage router can connect the devices." *See* Plaintiff's Brief, at 22. The defendants argue the term means "to translate addresses." *See* Defendants' Brief, Ex. 2.

In support of their definition, the defendants point only to a dictionary definition of "map." *See* Defendants' Brief, at 13 and Ex. 4. The plaintiff, on the other hand, cites to specific portions of the specification that support its definitions of map (both as a verb and a noun) as used in the claims of the '972 patent. *See* Plaintiff's Brief, at 22 (citing '972 Patent, at 1:66 - 2:5 and 6:65 - 7:6). Because intrinsic evidence is far more salient than a dictionary definition, and because the Court agrees that the specification language cited by the plaintiff supports its construction of the term "map," the Court will adopt the plaintiff's proposed definition of this term.

IX. "Fibre Channel protocol unit" and "SCSI protocol unit"

These terms are used in claims 5 and 6 of the '972 patent. The plaintiff contends these phrases should be defined as "a portion of the Fibre Channel controller which connects to the Fibre Channel transport medium" and "a portion of the SCSI controller which interfaces to the SCSI bus." *See* Plaintiff's Brief, at 27. The defendants say the terms mean "block and equivalents thereof that connects to the Fibre Channel transport medium" and "block and equivalents thereof that connects to the SCSI bus transport medium." *See* Defendants' Brief, Ex. 2.

The defendants argue the means-plus-function analysis of § 112(6) should apply here because the terms are well-known and are not defined in two dictionaries cited by the defendants. See Defendants' Brief, at 7-8, 14-15, Ex. 4 and Ex. 5. However, the defendants do not indicate how the term should be defined in reference to the specification, and in fact contend "the '972 specification fails to reveal any structure corresponding to the claimed function." See *id.* at 8 and 15. The defendants then propose the word "block" should be used to describe these terms because the "protocol units" are "simply depicted as a block within the diagram of Figure 5" of the '972 patent. See *id.* This reasoning is wholly unpersuasive. Simply because a figure in the patent physically depicts the protocol units in a block-like shape, it does not follow that the units should be defined as "blocks or equivalents thereof." Under that reasoning, the SCSI storage devices, which are physically depicted as cylinders in the '972 patent, could be defined simply as "cylinders, oil drums or monkey barrels, or equivalents thereof." As the plaintiff correctly points out, the language of claims 5 and 6 plainly states that the "protocol units" for both devices are part of the "controllers" for the devices, and are intended to "connect" the devices to various "transport media" (*i.e.*, to various cables). See '972 Patent, at Claims 5 and 6. Accordingly, the Court adopts the plaintiff's definitions for these terms, and will construe the terms to mean "a portion of the Fibre Channel controller which connects to the Fibre Channel transport medium" and "a portion of the SCSI controller which interfaces to the SCSI bus."

X. "interface"

In their Joint Stipulation of Claim Construction, the parties claim the meaning of the term "interface" is in dispute. However, this phrase is not discussed in any of the parties' briefs, and neither side presented an argument at the July 25 hearing as to why the term is disputed. This term

has a standard and ordinary meaning—even to a federal judge—and the Court will not further define it.

XI. Undisputed Terms

Finally, in their Joint Stipulation of Claim Construction, the parties have stipulated to the construction of 17 other terms in the '972 patent. The Court will therefore adopt these stipulated constructions, solely for the purpose of this lawsuit.

Accordingly, the Court enters the following order:

IT IS ORDERED that the attached construction of the patent claims will be incorporated into any jury instructions given in this cause and will be applied by the Court in ruling on the issues raised in summary judgment.

SIGNED on this 26th day of July 2000.

UNITED STATES DISTRICT JUDGE

**CONSTRUCTION OF CLAIMS
U.S. PATENT NO. 5,941,972**

Disputed Terms

The phrase "implements access controls for storage space on the SCSI storage devices" means provides controls which limit a computer's access to a specific subset of storage devices or sections of a single storage device.

The phrase "allocation of subsets of storage space to associated Fibre Channel devices, wherein each subset is only accessible by the associated Fibre Channel device" means subsets of storage space are allocated to specific Fibre Channel devices.

A "supervisor unit" is a microprocessor programmed to process data in a buffer in order to map between Fibre Channel devices and SCSI devices and which implements access controls.

A "SCSI storage device" is any storage device including, for example, a tape drive, CD-ROM drive, or a hard disk drive that understands the SCSI protocol and can communicate using the SCSI protocol.

The term "map" means to create a path from a device on one side of the storage router to a device on the other side of the router, *i.e.* from a Fibre Channel device to a SCSI device (or vice-versa). A "map" contains a representation of devices on each side of the storage router, so that when a device on one side of the storage router wants to communicate with a device on the other side of the storage router, the storage router can connect the devices.

A "Fibre Channel protocol unit" is a portion of the Fibre Channel controller which connects to the Fibre Channel transport medium.

A "SCSI protocol unit" is a portion of the SCSI controller which interfaces to the SCSI bus.

Stipulated / Undisputed Terms

A "buffer" is a memory device that is utilized to temporarily hold data.

A "direct memory access (DMA) interface" is a device that acts under little or no microprocessor control to access memory for data transfer.

A "Fibre Channel" is a known high-speed serial interconnect, the structure and operation of which is described, for example, in Fibre Channel Physical and Signaling Interface (FC-PH), ANSI X3.230 Fibre Channel Arbitrated Loop (FC-AL), and ANSI X3.272 Fibre Channel Private Loop Direct Attach (FC-PLDA).

A "Fibre Channel controller" is a device that interfaces with a Fibre Channel transport medium.

A "Fibre Channel device" is any device, such as a computer, that understands Fibre Channel protocol and can communicate using Fibre Channel protocol.

"Fibre Channel protocol" is a set of rules that apply to Fibre Channel.

A "Fibre Channel transport medium" is a serial optical or electrical communications link that connects devices using Fibre Channel protocol.

A "first-in-first-out queue" is a multi-element data structure from which elements can be removed only in the same order in which they were inserted; that is, it follows a first in, first out (FIFO) constraint.

A "hard disk drive" is a well known magnetic storage media, and includes a SCSI hard disk drive.

An "initiator device" is a device that issues requests for data or storage.

"Maintain(ing) a configuration" means keep(ing) a modifiable setting of information.

A "native low level, block protocol" is a set of rules or standards that enable computers to exchange information and do not involve the overhead of high level protocols and file systems typically required by network servers.

A "SCSI" (Small Computer System Interface) is a high speed parallel interface that may be used to connect components of a computer system.

A "SCSI bus transport medium" is a cable consisting of a group of parallel wires (normally 68) that forms a communications path between a SCSI storage device and another device, such as a computer.

A "SCSI controller" is a device that interfaces with the SCSI bus transport medium.

"Virtual local storage" is a specific subset of overall data stored in storage devices that has the appearance and characteristics of local storage.

A "workstation" is a remote computing device that connects to the Fibre Channel, and may consist of a personal computer.

**This Page is Inserted by IFW Indexing and Scanning
Operations and is not part of the Official Record**

BEST AVAILABLE IMAGES

Defective images within this document are accurate representations of the original documents submitted by the applicant.

Defects in the images include but are not limited to the items checked:

- BLACK BORDERS
- IMAGE CUT OFF AT TOP, BOTTOM OR SIDES
- FADED TEXT OR DRAWING
- BLURRED OR ILLEGIBLE TEXT OR DRAWING
- SKEWED/SLANTED IMAGES
- COLOR OR BLACK AND WHITE PHOTOGRAPHS
- GRAY SCALE DOCUMENTS
- LINES OR MARKS ON ORIGINAL DOCUMENT
- REFERENCE(S) OR EXHIBIT(S) SUBMITTED ARE POOR QUALITY
- OTHER: _____

IMAGES ARE BEST AVAILABLE COPY.

As rescanning these documents will not correct the image problems checked, please do not report these problems to the IFW Image Problem Mailbox.

IN THE UNITED STATES PATENT AND TRADEMARK OFFICE	
NOTIFICATION UNDER 37 C.F.R. 1.565 NOTIFICATION OF STAY	Atty. Docket No. CROSS1123-17 CROSS1123-19
Applicant Geoffrey B. Hoese, et al.	
Application Number 90/007,125 90/007,317	Date Filed 07/19/2004 11/23/2004
Title Storage Router and Method for Providing Virtual Local Storage	
Group Art Unit 2182	Examiner Fleming, Fritz, M.
Confirmation Number: 2298 and 1634	

Commissioner for Patents
P.O. Box 1450
Alexandria, VA 22313-1450

Dear Sir:

Certificate of Mailing Under 37 C.F.R. §1.8
I hereby certify that this correspondence is being deposited with the United States Postal Service as First Class Mail in an envelope addressed to Commissioner for Patents, P.O. Box 1450, Alexandria, VA 22312-1450 on March 30 2005
<i>Janice Pampell</i> Janice Pampell

This notification is filed for the sole purpose to inform the Examiner of status of ongoing litigation involving United States Patent No. 5,941,972 (the "972 Patent") and United States Patent No. 6,425,035 (the "035 Patent").

Attorney Docket No.
CROSS1123-17
CROSS1123-19

Customer No. 44654
Appln. No. 90/007,125
Appln. No. 90/007,317

2

ONGOING LITIGATION

Attached hereto as Exhibit "A" is a March 17, 2005 Order from the United States District Court for the Western District of Texas. The Court ordered Crossroads to file a copy of this Order with the U.S. Patent Office in the reexamination proceedings involving U.S. Patents 5,941,972 and 6,425,035 B2.

This notification was served via first class mail on March 30, 2005 to:

Larry E. Severin
Wang, Hartmann & Gibbs, PC
1301 Dove Street, #1050
Newport Beach, CA 92660

and

William A. Blake
Jones, Tullar & Cooper, PC
P.O. Box 2226 Eads Station
Alexandria, VA 22202

Respectfully submitted,

Sprinkle IP Law Group
Attorneys for Applicant

John L. Adair
Reg. No. 48,828

Date: March 30, 2005
1301 W. 25th Street
Suite 408
Austin, Texas 78705
Tel. (512) 637-9220
Fax. (512) 371-9088

IN THE UNITED STATES DISTRICT COURT
FOR THE WESTERN DISTRICT OF TEXAS
AUSTIN DIVISION

FILED
AUSTIN DIVISION

2005 MR 22 PM 2:03

WESTERN DISTRICT OF TEXAS
U.S. CLERK'S OFFICE

BY: AF
DEPUTY

CROSSROADS SYSTEMS (TEXAS), INC.,
Plaintiff,

-vs-

Case No. A-03-CA-754-SS

DOT HILL SYSTEMS CORPORATION,
Defendant.

ORDER

BE IT REMEMBERED on the 17th day of March 2005, the Court called the above-styled cause for hearing on Defendant's Motion for a Limited Six-Month Abatement [#256]. Having considered the motion and response, the relevant law, the case file as a whole, and the arguments of counsel at the hearing, the Court now enters the following:

In this action, Plaintiff Crossroads Systems (Texas), Inc. ("Crossroads") sues Defendant Dot Hill Systems Corporation ("Dot Hill") for infringing the claims of two of its patents, United States Patent No. 5,941,972, entitled "Storage Router and Method for Providing Virtual Local Storage," and United States Patent No. 6,425,035 B2, which bears the same title and is a continuation of the '972 patent. Dot Hill now seeks a stay of the proceedings in this case based on reexaminations of the patents-in-suit that are currently taking place in the United States Patents and Trademark Office ("USPTO"). The Court has previously declined to stay this action because of its inability to predict the amount of time it will take the USPTO to conclude its reexamination proceedings.

267

SS
MB

03/23/2005 WED 15:52 [TX/RX NO 6412]

However, the Court is now advised the USPTO has issued an initial office action canceling all of the claims of the patents-in-suit. Although the uncertainty about the length of time it will take the USPTO to make a final determination on the claims of the patents-in-suit remains, the Court finds it appropriate to enter a short stay of the case to give it an opportunity to do so. After all, if the USPTO ultimately cancels all of the claims in the patents, Crossroads would no longer have a basis for its infringement allegations. *Slip Track Sys., Inc. v. Metal Lite, Inc.*, 159 F.3d 1337, 1341 (Fed. Cir. 1998) (noting that a stay may be justified when "the outcome of the reexamination would be likely to assist the court in determining patent validity and, if the claims were canceled in the reexamination, would eliminate the need to try the infringement issue."). Moreover, if the reexamination proceedings were to result in an amendment of the patent claims, the issues raised by the claim construction proceedings and pending motion for summary judgment could be substantially altered.

Thus, the Court agrees with Dot Hill that under the circumstances, a stay is justified in this case. Bearing in mind Crossroads's interest in moving this case forward, however, the Court declines to stay this case indefinitely, or even for six months, as requested. Instead, the Court considers it appropriate to stay the case from now until ninety (90) days following April 7, 2005 (the date on which Crossroads must file its answer to the USPTO's initial office action in the reexamination proceedings). The Court finds this period of time strikes the appropriate balance between the general interest in affording the USPTO an opportunity to reach a final determination on the status of the claims of the patents-in-suit, and the plaintiff's interest in moving the case forward.

Because the Court is convinced there is an appreciable probability that the issues in the now-pending motion for summary judgment will no longer require resolution by the Court at the conclusion of the reexamination proceedings, the Court will dismiss the motion without prejudice to the filing of a renewed motion for summary judgment on any and all live issues remaining at the conclusion of the stay.¹

In accordance with the foregoing:

IT IS ORDERED that Defendant's Motion for Leave to Supplement its Motion for a Limited Six-Month Abatement [#263] is GRANTED;

IT IS FURTHER ORDERED that Defendant's Motion for a Limited Six-Month Abatement [#256] is GRANTED IN PART and DENIED IN PART as set forth herein;

IT IS FURTHER ORDERED that this case is STAYED until July 5, 2005;

IT IS FURTHER ORDERED that Plaintiff Crossroads shall file a copy of this order in the reexamination proceedings involving the patents-in-suit so that the USPTO may assign those proceedings as high a priority as the law, practicability, and justice will permit;

IT IS FURTHER ORDERED that Plaintiff Crossroads shall notify the Court of the status of the reexamination proceedings within ten (10) days of either the

¹ The Court notes the parties have already filed substantial amounts of paper with respect to the summary judgment issues. The Court also notes the parties have a tendency to submit duplicate copies of evidentiary submissions already on file whenever they file a new pleading. Since the file in this case appears to be growing unnecessarily thick, the Court would advise the parties of the following. In the event either the evidence or the arguments contained in the parties' now-moot summary judgment pleadings remain relevant to the issues in this case at the conclusion of the stay, the parties should feel free to incorporate them by specific reference in any post-stay pleadings they may ultimately file with the Court.

conclusion of the stay, or the date on which the USPTO issues a final determination in the reexamination proceedings, if a conclusion is reached prior to the expiration of the stay; and

IT IS FINALLY ORDERED that Defendant's Motion for Summary Judgment that U.S. Patent No. 6,425,035 and U.S. Patent No. 5,941,972 are Invalid Pursuant to 35 U.S.C. § 102 and/or 103 in View of the Prior Development of Digital Equipment Corporation HSZ70 Controller [#85] and Defendant's Request for Judicial Notice in Support of its Motion for Summary Judgment [#86] are DISMISSED WITHOUT PREJUDICE to refiling as set forth herein.

SIGNED this the 22nd day of March 2005.

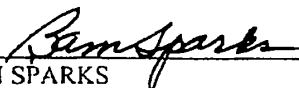

SAM SPARKS
UNITED STATES DISTRICT JUDGE

IN THE UNITED STATES PATENT AND TRADEMARK OFFICE	
CERTIFICATE OF SERVICE UNDER 37 C.F.R. 1.248	Atty. Docket No. CROSS1123-17 CROSS1123-19
Applicant Geoffrey B. Hoese, et al.	
Application Number 90/007,125 90/007,317	Date Filed 07/19/2004 07/19/2004
Title Storage Router and Method for Providing Virtual Local Storage	
Group Art Unit 2182	Examiner Fleming, Fritz

4660 U.S. PTO



Applicant hereby serves the Information Disclosure Statement, SBO8A and SBO8B forms, copies of references A1-A59, B1-B9 and C1-C32 and copies of References C33-C110, which are located on the attached CD-Rom, in the above referenced case to:

Larry E. Severin
Wang, Hartmann & Gibbs, PC
1301 Dove Street, #1050
Newport Beach, CA 92660

William A. Blake
Jones, Tullar & Cooper, PC
P.O. Box 2226 Eads Station
Alexandria, VA 22202

As per 35 U.S.C. §1.248 service is made via first class mail on March 23, 2005.

Respectfully submitted,

Sprinkle IP Law Group

John L. Adair
Reg. No. 48,828

Dated: March 23 2005

1301 W. 25th Street, Suite 408
Austin, Texas 78705
Tel. (512) 637-9220
Fax. (512) 371-9088

Enclosures

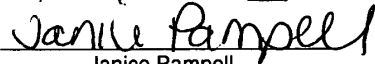
IN THE UNITED STATES PATENT AND TRADEMARK OFFICE	
INFORMATION DISCLOSURE STATEMENT BY APPLICANTS	Atty. Docket No. (Opt.) CROSS1123-17 CROSS1123-19
Applicants Geoffrey B. Hoese et al.	
Application Number 90/007,125 90/007,317	Filed 07/19/2004 07/19/2004
For Storage Router and Method for Providing Virtual Local Storage	
Group Art Unit 2182	Examiner Fleming, Fritz M.
<u>Certification Under 37 C.F.R. §1.8</u>	
I hereby certify that this document is being deposited with the United States Postal Service as First Class Mail in an envelope addressed to: Commissioner for Patents, P.O. Box 1450, Alexandria, VA 22313 on March 21, 2005 .	
 Janice Pampell	

Commissioner for Patents
P.O. Box 1450
Alexandria, VA 22313

Applicants respectfully request, pursuant to 37 C.F.R. §§ 1.555, 1.56, 1.97 and 1.98, that the art listed on the attached SBO8-A and SBO8-B forms be considered and cited in the examination of the above-identified reexamination application. Since the present Application was filed after June 30, 2003, a copy of any U.S. Patent and any U.S. Patent Application Publications cited on the attached SBO8-A form is not being submitted with this Information Disclosure Statement pursuant to the waiver of 37 C.F.R. S 1.98(a)(2)(i) by the U.S. Patent and Trademark Office. Several documents are included on the enclosed CD-Rom for the convenience of the Examiner. If the Examiner would like hard copies of these documents, we will gladly provide them.

Furthermore, pursuant to 37 C.F.R. §§ 1.97(g) and (h), no representation is made that a search has been made or that this art is material to patentability of the present application. Applicants respectfully submit that the claims of Applicants' above-referenced patent is patentably distinguishable from these references. Applicants respectfully request consideration of these references. The Commissioner is hereby authorized to charge any fees due, or refund any credit, to Deposit Account No. 50-3183 of Sprinkle IP Law Group for any fee under 37 C.F.R. §1.17.

Respectfully submitted,
Sprinkle IP Law Group
Attorneys for Applicants

John L. Adair
Reg. No. 48,828

Dated: *3/23/05*
1301 W. 25th Street, Suite 408
Austin, TX 78705
T. 512-637-9220 / F. 512-371-9088

INFORMATION DISCLOSURE STATEMENT BY APPLICANT				Application Number		90/007,125 & 90/007,317	
				Filing Date		07/19/2004	
				First Named Inventor		Hoese, Geoffrey	
				Group Art Unit		2182	
				Examiner Name		Fleming, Fritz M.	
Sheet	1	OF	2	Attorney Docket Number		CROSS1123-17 & CROSS1123-19	
U.S. PATENT DOCUMENTS							
Examiner Initials	Cite No.	Document Number		Publication Date MM-DD-YYYY	Name of Patentee or Applicant of Cited Document	Pages, Columns, Lines Where Relevant Passages or Figures Appear	
		Number	Kind Code (if known)				
	A1	3,082,406		03/19/1963	L.D. Stevens		
	A2	4,092,732		05/30/1978	Ouchi		
	A3	4,695,948		09/22/1987	Blevins, et al.		
	A4	4,751,635		06/14/1988	Kret		
	A5	4,864,532		09/05/1989	Reeve, et al.		
	A6	4,947,367		08/07/1990	Chang, et al.		
	A7	5,072,378		12/10/1991	Manka		
	A8	5,163,131		11/10/1992	Row, et al.		
	A9	5,239,632		08/24/1993	Larner		
	A10	5,239,643		08/24/1993	Blount, et al.		
	A11	5,257,386		10/26/1993	Saito		
	A12	5,347,384		09/13/1994	McReynolds, et al.		
	A13	5,414,820		10/09/1995	McFarland, et al.		
	A14	5,423,044		06/06/1995	Sutton, et al.		
	A15	5,465,382		11/07/1995	Day, III, et al.		
	A16	5,530,845		06/25/1996	Hiatt, et al.		
	A17	5,535,352		07/09/1996	Bridges, et al.		
	A18	5,581,714		12/03/1996	Amini, et al.		
	A19	5,596,562		06/21/1997	Chen		
	A20	5,596,736		01/21/1997	Kerns		
	A21	5,598,541		01/28/1997	Malladi		
	A22	5,680,556		10/21/1997	Begun, et al.		
	A23	5,701,491		12/23/1997	Dunn, et al.		
	A24	5,712,976		01/27/1998	Falcon, et al.		
	A25	5,729,705		03/17/1998	Weber		
	A26	5,743,847		04/28/1998	Nakamura, et al.		
	A27	5,751,975		05/12/1998	Gillespie, et al.		
	A28	5,774,683		06/30/1998	Gulick		
	A29	5,845,107		12/01/1998	Fisch, et al.		
	A30	5,857,080		10/05/1999	Jander, et al.		
	A31	5,864,653		01/26/1999	Tavallaei, et al.		
	A32	5,867,648		02/02/1999	Foth, et al.		

	A33	5,884,027			03/16/1999	Garbus, et al.	
	A34	5,913,045			06/15/1999	Gillespie, et al.	
	A35	5,923,557			07/13/1999	Eidson	
	A36	5,941,969			08/24/1999	Ram, et al.	
	A37	5,949,994			09/28/1999	Boggs, et al.	
	A38	5,953,511			09/14/1999	Sescilia, et al.	
	A39	5,974,530			10/26/1999	Young	
	A40	5,978,379			11/02/1999	Chan, et al.	
	A41	5,991,797			11/23/1999	Futral, et al.	
	A42	6,000,020			12/07/1999	Chin, et al.	
	A43	6,021,451			02/01/2000	Bell, et al.	
	A44	6,070,253			01/26/1999	Tavallaei, et al.	
	A45	6,131,119			10/10/2000	Fukui	
	A46	6,134,617			10/17/2000	Weber	
	A47	6,141,737			10/31/2000	Krantz, et al.	
	A48	6,145,006			11/07/2000	Vishlitsky, et al.	
	A49	6,223,266			04/24/2001	Sartore	
	A50	6,230,218			05/08/2001	Casper, et al.	
	A51	6,260,120			07/10/2001	Blumenau, et al.	
	A52	6,330,629			12/11/2001	Kondo et al.	
	A53	6,363,462			03/26/2002	Bergsten	
	A54	6,421,753			07/16/2002	Hoese, et al.	
	A55	6,425,035			07/23/2002	Hoese, et al.	
	A56	6,425,036			07/23/2002	Hoese, et al.	
	A57	6,484,245			11/19/2002	Sanada, et al.	
	A59	6,529,996			03/04/2003	Nguyen, et al.	
Examiner Initials	FOREIGN PATENT DOCUMENTS			Publication Date MM-DD-YYYY (Number 43)	Name of Patentee or Applicant of Cited Document	Pages, Columns, Lines Where Relevant Passages or Figures Appear	
	Country Code	Number	Kind Code (<i>if known</i>)				
	B1	GB 2296798		A	07/10/1996	Spring Consultants Limited	
	B2	GB 2297636		A	08/07/1996	Spring Consultants Limited	
	B3	JP 8-230895			09/10/1996	Kikuchi, et al.	
	B4	EP 0810530		A2	12/03/1997	Sun Microsystems, Inc.	
	B5	EP 0827059		A2	03/04/1998	NEC Corporation	
	B6	WO 99/34297		A1	07/08/1999	Crossroads Systems, Inc.	
	B7	GB 2341715					
	B8	JP 6301607					
	B9	WO 98/36357			1998		
Examiner Signature				Date Considered			

FORM PTO 1449 US Department of Commerce Patent and Trademark Office			Application Number	90/007,125 & 90/007,317	
			Filing Date	July 19, 2004	
			First Named Inventor	Hoese, Geoffrey	
			Group Art Unit	2182	
			Examiner Name	Fleming, Fritz M.	
Sheet	1	of	6	Atty Docket Number	CROSS1123-17 & CROSS1123-19
Examiner Initials	Cite No.	OTHER PRIOR ART -- NON PATENT LITERATURE DOCUMENTS			Date
	C1	Black Box, SCSI Fiberoptic Extender, Single-Ended, Product Insert, 2 pages, 1996.			6/18/05
	C2	Burskey, Dave "New Serial I/Os Speed Storage Subsystems" February 6, 1996			
	C3	CRD-5500, RAID DISK ARRAY CONTROLLER Product Insert, pp. 1-5			
	C4	CRD-5500, SCSI RAID CONTROLLER OEM Manual, Rev. 1.3, February 26, 1996, pp. 1-54.			
	C5	Raidtec FibreArray and Raidtec FlexArray UltraRAID Systems", Windows IT PRO Article, October 1997.			
	C6	DIGITAL Storage Works, HSZ70 Array Controller, HSOF Version 7.0 EK-HSZ70-CG. A01, Digital Equipment Corporation, Maynard, Massachusetts.			
	C7	DIGITAL StorageWorks, Using Your HSZ70 Array Controller in a SCSI Controller Shelf (DS-BA356-M Series), User's Guide, pp. 1-1 through A-5 with index, January 1998.			
	C8	DIGITAL StorageWorks HSZ270 Array Controller HSOF Version 7.0 EK-HSZ270-RM. A01. CLI Reference Manual			
	C9	DIGITAL StorageWorks HSG80 Array Controller ACS Version 8.0 (User's Guide) 1/98			
	C10	DIGITAL StorageWorks HSZ70 Array Controller HSOF Version 7.0 EK-HSZ70-SV. A01			
	C11	Emerson, "Ancor Communications: Performance evaluation of switched fibre channel I/O system using--FCP for SCSI" February 1995, IEEE, pp. 479-484.			
	C12	IBM Technical Publication: Magstar and IBM 3590 High Performance Tape Subsystem Technical Guide, November 1996, pp. 1-269.			
	C13	Guide to Sharing and Partitioning IBM Tape Library Dataservers, November 1996, IBM, International Technical Support Organization, San Jose Center			
	C14	Misc. Reference Manual Pages, SunOS 5.09.			
	C15	Block-Based Distributed File Systems, Anthony J. McGregor, July 1997.			
	C16	InfoServer 150VXT Photograph			
	C17	Pictures of internal components of the InfoServer 150, taken from http://bindarydinosaurs.couk/Museum/Digital/infoserver/infoserver.php in Nov. 2004.			
	C18	Simplest Migration to Fibre Channel Technology			
	C19	Compaq StorageWorks HSG80 Array Controller ACS Version 8.3 (Maintenance and Service Guide) 11/98			
	C20	Compaq StorageWorks HSG80 Array Controller ACS Version 8.3 (Configuration and CLI Reference Guide) 11/98			
	C21	Office Action dated 01/21/03 for 10/174,720 (CROSS1120-8).			
	C22	Office Action dated 02/27/01 for 09/354,682 (CROSS1120-1).			

	C23	Office Action dated 08/11/00 for 09/354,682 (CROSS1120-1).	
	C24	Office Action dated 12/16/99 for 09/354,682 (CROSS1120-1).	
	C25	Office Action dated 11/06/02 for 10/023,786 (CROSS1120-4).	
	C26	Office Action dated 01/21/03 for 10/081,110 (CROSS1120-5).	
	C27	Office Action dated 1/27/2005 in 10/658,163 (CROSS1120-13)	
	C28	Office Action in Ex Parte Reexamination 90/007,127, mailed 0207/05.	
	C29	Office Action in Ex Parte Reexamination 90/007,126, mailed 0207/05.	
	C30	Office Action in Ex Parte Reexamination 90/007,124, mailed 0207/05.	
	C31	Office Action in Ex Parte Reexamination 90/007,123, mailed 0207/05.	
	C32	European Office Action issued April 1, 2004 in Application No. 98966104.6-2413	
		Copies of the following are on the attached CD-Rom	
	C33	Defendant's First Supplemental Trial Exhibit List, Crossroads Systems, Inc., v. Chaparral Network Storage, Inc., C.A. No. A-00CA-217-SS (W.D. Tex. 2001). (CD-Rom) .	
	C34	Defendant's Third Supplemental Trial Exhibit List, Crossroads Systems, Inc. v. Pathlight Technology, Inc., C.A. No. A-00CA-248-SS (W.D. Tex. 2001) (CD-Rom) .	
	C35	Defendant's Trial Exhibits, Crossroads Systems, Inc. v. Pathlight Technology, Inc., C.A. No. A-00CA-248-SS (W.D. Tex. 2001). (CD-Rom) .	
	C36	Defendants' Trial Exhibits, Crossroads Systems, Inc., v. Chaparral Network Storage, Inc., C.A. No. A-00CA-217-SS (W.D. Tex. 2001). (CD-Rom) .	
	C37	Defendant Chaparral Network Storage, Inc.'s First Supplemental Trial Exhibit List (D1 through D271) (CD-ROM Chaparral Exhibits ExList_Def) .	9/2/2001
	C38	Defendant Pathlight Technology Inc.'s Third Supplemental Trial Exhibit List (CD-ROM Pathlight Exhibits ExList_Def).	
	C39	Plaintiff's Fourth Amended Trail Exhibit List, Crossroads Systems, Inc. v. Chaparral Network Storage, Inc, C.A. No. A-00CA-217-SS (W.D. Tex. 2001) (CD-Rom) .	9/11/2001
	C40	Plaintiff's Revised Trial Exhibit List, Crossroads Systems, Inc. v. Pathlight Technology, Inc., C.A. No. A-00CA-248-SS (W.D. Tex. 2001). (CD-Rom) .	
	C41	Plaintiff's Trial Exhibits, Crossroads Systems, Inc. v. Chaparral Networks Storage, Inc., C.A. No. A-00CA-217-SS (W.D. Tex. 2001). (CD-Rom) .	
	C42	Plaintiff's Fourth Amended Trail Exhibit List (CD-ROM Chaparral Exhibits ExList_Plaintiff) .	9/11/2001
	C43	Plaintiff's Revised Trail Exhibit List (CD-ROM Pathlight Exhibits ExList_Plaintiff) .	
	C44	Trail Transcripts, Crossroads Systems, Inc. v. Chaparral Network Storage, Inc., C.A. No. A-00CA-217-SS (W.D. Tex. 2001) (CD-Rom) .	
	C45	Trail Transcripts, Crossroads Systems, Inc. v. Pathlight Technology, Inc., C.A. No. A-00CA-248-SS (W.D. Tex. 2001). (CD-Rom) .	
	C46	Trial Exhibits and Transcripts, Crossroads v. Chaparral, Civil Action No. A-00CA-21755, W.D. Tex. 2000 (CD-Rom and hard copy printouts) .	
	C47	Snively, "Sun Microsystem Computer Corporation: Implementing a fibre optic channel SCSI transport" 1994 IEEE, February 28, 1994, pp. 78-82.	
	C48	Datasheet for CrossPoint 4100 Fibre Channel to SCSI Router (Dedek Ex 41 (ANCT 117-120)) (CD-ROM Chaparral Exhibits D012) .	

C49	Symbios Logic- Software Interface Specification Series 3 SCSI RAID Controller Software Release 02.xx (Engelbrecht Ex 2 (LSI 1421-1658)) (CD-ROM Chaparral Exhibits D013).	12/3/1997
C50	Press Release- Symbios Logic to Demonstrate Strong Support for Fibre Channel at Fall Comdex (Engelbrecht 12 (LSI 2785-86)) (CD-ROM Chaparral Exhibits D016).	11/13/1996
C51	OEM Datasheet on the 3701 Controller (Engelbrecht 13 (LSI 01837-38)) (CD-ROM Chaparral Exhibits D017).	6/17/1905
C52	Nondisclosure Agreement Between Adaptec and Crossroads Dated 10/17/96 (Quisenberry Ex 25 (CRDS 8196)) (CD-ROM Chaparral Exhibits D020).	10/17/1996
C53	Organizational Presentation on the External Storage Group (Lavan Ex 1 (CNS 182242-255)) (CD-ROM Chaparral Exhibits D021).	4/11/1996
C54	Bridge. C, Bridge Between SCSI-2 and SCSI-3 FCP (Fibre Channel Protocol) (CD-ROM Chaparral Exhibits P214).	
C55	Bridge Phase II Architecture Presentation (Lavan Ex 2 (CNS 182287-295)) (CD-ROM Chaparral Exhibits D022).	4/12/1996
C56	Attendees/Action Items from 4/12/96 Meeting at BTC (Lavan Ex 3 (CNS 182241)) (CD-ROM Chaparral Exhibits D023).	4/12/1996
C57	Brooklyn Hardware Engineering Requirements Documents, Revision 1.4 (Lavan Ex 4 (CNS 178188-211)) (CD-ROM Chaparral Exhibits D024) by Pecone.	5/26/1996
C58	Brooklyn Single-Ended SCSI RAID Bridge Controller Hardware OEM Manual, Revision 2.1 (Lavan EX 5 (CNS 177169-191)) (CD-ROM Chaparral Exhibits D025).	3/21/1996
C59	Coronado Hardware Engineering Requirements Document, Revision 0.0 (Lavan Ex 7 (CNS 176917-932)) (CD-ROM Chaparral Exhibits D027) by O'Dell.	9/30/1996
C60	ESS/FPG Organization (Lavan Ex 8 (CNS 178639-652)) (CD-ROM Chaparral Exhibits D028).	12/6/1996
C61	Adaptec MCS ESS Presents: Intelligent External I/O Raid Controllers "Bridge" Strategy (Lavan Ex 9 (CNS 178606-638)). (CD-ROM Chaparral Exhibits D029).	2/6/1996
C62	AEC-7313 Fibre Channel Daughter Board (for Brooklyn) Engineering Specification, Revision 1.0 (Lavan Ex 10 (CNS 176830-850)) (CD-ROM Chaparral Exhibits D030).	2/27/1997
C63	Bill of Material (Lavan Ex 14 (CNS 177211-214)) (CD-ROM Chaparral Exhibits D034).	7/24/1997
C64	AEC-. 4412B, AEC-7412/B2 External RAID Controller Hardware OEM Manual, Revision 2.0 (Lavan Ex 15 (CNS 177082-123)) (CD-ROM Chaparral Exhibits D035).	6/27/1997
C65	Coronado II, AEC-7312A Fibre Channel Daughter (for Brooklyn) Hardware Specification, Revision 1.2 (Lavan Ex 16 (CNS 177192-210)) (CD-ROM Chaparral Exhibits D037) by Tom Yang.	7/18/1997
C66	AEC-4412B, AEC7412/3B External RAID Controller Hardware OEM Manual, Revision 3.0. (Lavan Ex 17 (CNS 177124-165)) (CD-ROM Chaparral Exhibits D036).	8/25/1997
C67	Memo Dated 8/15/97 to AEC-7312A Evaluation Unit Customers re: B001 Release Notes (Lavan Ex 18 (CNS 182878-879)) (CD-ROM Chaparral Exhibits D038),	8/15/1997
C68	Brooklyn Main Board (AES-0302) MES Schedule (Lavan Ex 19 (CNS 177759-763)) (CD-ROM Chaparral Exhibits D039).	2/11/1997
C69	News Release-Adaptec Adds Fibre Channel Option to its External RAID Controller Family (Lavan Ex 20 (CNS 182932-934)) (CD-ROM Chaparral Exhibits D040).	5/6/1997

C70	AEC-4412B/7412B User's Guide, Rev. A (Lavan Ex 21) (CD-ROM Chaparral Exhibits D041).	6/19/1905
C71	Data Book- AIC-7895 PCI Bus Master Single Chip SCSI Host Adapter (Davies Ex 1 (CNS 182944-64)) (CD-ROM Chaparral Exhibits D046).	5/21/1996
C72	Data Book- AIC-1160 Fibre Channel Host Adapter ASIC (Davies Ex 2 (CNS 181800-825)) (CD-ROM Chaparral Exhibits D047).	6/18/1905
C73	Viking RAID Software (Davies Ex 3 (CNS 180969-181026)) (CD-ROM Chaparral Exhibits D048).	6/18/1905
C74	Header File with Structure Definitions (Davies Ex 4 (CNS 180009-018)) (CD-ROM Chaparral Exhibits D049).	8/8/1996
C75	C++ SourceCode for the SCSI Command Handler (Davies Ex 5 (CNS 179136-168)) (CD-ROM Chaparral Exhibits D050).	8/8/1996
C76	Header File Data Structure (Davies Ex 6 (CNS 179997-180008)) (CD-ROM Chaparral Exhibits D051).	1/2/1997
C77	SCSI Command Handler (Davies Ex 7 (CNS 179676-719)) (CD-ROM Chaparral Exhibits D052).	1/2/1997
C78	Coronado: Fibre Channel to SCSI Intelligent RAID Controller Product Brief (Kalwitz Ex 1 (CNS 182804-805)) (CD-ROM Chaparral Exhibits D053).	
C79	Bill of Material (Kalwitz Ex 2 (CNS 181632-633)) (CD-ROM Chaparral Exhibits D054).	3/17/1997
C80	Emails Dated 1/13-3/31/97 from P. Collins to Mo re: Status Reports (Kalwitz Ex 3 (CNS 182501-511)) (CD-ROM Chaparral Exhibits D055).	
C81	Hardware Schematics for the Fibre Channel Daughtercard Coronado (Kalwitz Ex 4 (CNS 181639-648)) (CD-ROM Chaparral Exhibits D056).	
C82	Adaptec Schematics re AAC-340 (Kalwitz Ex 14 CNS 177215-251)) (CD-ROM Chaparral Exhibits D057).	
C83	Bridge Product Line Review (Manzanares Ex 3 (CNS 177307-336)) (CD-ROM Chaparral Exhibits D058).	
C84	AEC Bridge Series Products-Adaptec External Controller RAID Products Pre-Release Draft, v.6 (Manzanares Ex 4 (CNS 174632-653)). (CD-ROM Chaparral Exhibits D059).	10/28/1997
C85	Hewlett-Packard Roseville Site Property Pass for Brian Smith (Dunning Ex 14 (HP 489) (CD-ROM Chaparral Exhibits D078).	11/7/1996
C86	Distribution Agreement Between Hewlett-Packard and Crossroads (Dunning Ex 15 (HP 326-33) (CD-ROM Chaparral Exhibits D079).	
C87	HPFC-5000 Tachyon User's Manuel, First Edition (PTI 172419-839) (CD-ROM Chaparral Exhibits D084).	5/1/1996
C88	X3T10 994D - (Draft) Information Technology: SCSI-3 Architecture Model, Rev. 1.8 (PTI 165977) (CD-ROM Chaparral Exhibits D087).	
C89	X3T10 Project 1047D: Information Technology- SCSI-3 Controller Commands (SCC), Rev, 6c (PTI 166400-546) (CD-ROM Chaparral Exhibits D088).	9/3/1996
C90	X3T10 995D- (Draft) SCSI-3 Primary Commands, Rev. 11 (Wanamaker Ex 5 (PTI 166050-229)) (CD-ROM Chaparral Exhibits D089).	11/13/1996
C91	VBAR Volume Backup and Restore (CRDS 12200-202) (CD-ROM Chaparral Exhibits D099).	
C92	Preliminary Product Literature for Infinity Commstor's Fibre Channel to SCSI Protocol Bridge (Smith Ex 11; Quisenberry Ex 31 (SPLO 428-30) (CD-ROM Chaparral Exhibits D143).	8/19/1996
C93	Letter dated 7/12/96 from J. Boykin to B. Smith re: Purchase Order for Evaluation Units from Crossroads (Smith Ex 24) CRDS 8556-57) (CD-ROM Chaparral Exhibits D144).	7/12/1996

	C94	CrossPoint 4100 Fibre Channel to SCSI Router Preliminary Datasheet (Hulsey Ex 9 (CRDS 16129-130)) (CD-ROM Chaparral Exhibits D145).	11/1/1996
	C95	CrossPoint 4400 Fibre Channel to SCSI Router Preliminary Datasheet (Bardach Ex. 9, Quisenberry Ex 33 (CRDS 25606-607)) (CD-ROM Chaparral Exhibits D153).	11/1/1996
	C96	Fax Dated 07/22/96 from L. Petti to B. Smith re: Purchase Order from Data General for FC2S Fibre to Channel SCSI Protocol Bridge Model 11 (Smith Ex 25; Quisenberry Ex 23; Bardach Ex 11 (CRDS 8552-55; 8558)) (CD-ROM Chaparral Exhibits D155).	
	C97	Email Dated 12/20/96 from J. Boykin to B. Smith re: Purchase Order for Betas in February and March (Hoese Ex 16, Quisenberry Ex 25; Bardach Ex 12 (CRDS 13644-650)) (CD-ROM Chaparral Exhibits D156).	
	C98	Infinity Commstor Fibre Channel Demo for Fall Comdex, 1996 (Hoese Ex 15, Bardach Ex 13 (CRDS 27415)) (CD-ROM Chaparral Exhibits D157).	
	C99	Fax Dated 12/19/96 from B. Bardach to T. Rarich re: Purchase Order Information (Bardach Ex. 14; Smith Ex 16 (CRDS 4460)) (CD-ROM Chaparral Exhibits D158).	
	C100	Miscellaneous Documents Regarding Comdex (Quisenberry Ex 2 (CRDS 27415-465)) (CD-ROM Chaparral Exhibits D165).	
	C101	CrossPoint 4100 Fibre Channel to SCSI Router Preliminary Datasheet (Quisenberry) Ex 3 (CRDS 4933-34) (CD-ROM Chaparral Exhibits D166) (CD-ROM Chaparral Exhibits D166).	
	C102	CrossPoint 4400 Fibre to Channel to SCSI Router Preliminary Datasheet; Crossroads Company and Product Overview (Quisenberry Ex 4 (CRDS 25606; 16136)) (CD-ROM Chaparral Exhibits D167).	
	C103	Crossroads Purchase Order Log (Quisenberry Ex 9 (CRDS 14061-062)) (CD-ROM Chaparral Exhibits D172).	
	C104	RAID Manager 5 with RDAC 5 for UNIX V.4 User's Guide (LSI-01854) (CD-ROM Chaparral Exhibits P062).	9/1/1996
	C105	Letter dated May 12, 1997 from Alan G. Leal to Barbara Bardach enclosing the original OEM License and Purchase Agreement between Hewlett-Packard Company and Crossroads Systems, Inc. (CRDS 02057) (CD-ROM Chaparral Exhibits P130).	
	C106	CR4x00 Product Specification (CRDS 43929) (CD-ROM Chaparral Exhibits P267).	6/1/1998
	C107	Symbios Logic – Hardware Functional Specification for the Symbios Logic Series 3 Fibre Channel Disk Array Controller Model 3701 (Engelbrecht Ex 3 (LSI-1659-1733)) (CD-ROM Pathlight Exhibits D074).	
	C108	Report of the Working Group on Storage I/O for Large Scale Computing; Department of Computer Science Duke University: CS-1996-21 (PTI 173330-347). (CD-ROM Pathlight Exhibits D098).	
	C109	Brian Allison's 1999 Third Quarter Sales Plan (PDX 38)CNS 022120-132)) (CD-ROM Pathlight Exhibits D201).	6/5/2001
	C110	Brooklyn SCSI-SCSI Intelligent External RAID Bridge Definition Phase External Documentation (CD-ROM Pathlight Exhibits D129).	
Examiner Signature		Date Considered	

ARTIFACT SHEET

Enter artifact number below. Artifact number is application number + artifact type code (see list below) + sequential letter (A, B, C ...). The first artifact folder for an artifact type receives the letter A, the second B, etc.. Examples: 59123456PA, 59123456PB, 59123456ZA, 59123456ZB

90/007317 ZA (3/25/05)

Indicate quantity of a single type of artifact received but not scanned. Create individual artifact folder/box and artifact number for each Artifact Type.

CD(s) containing:
 computer program listing
Doc Code: Computer Artifact Type Code: P
pages of specification
and/or sequence listing
and/or table
Doc Code: Artifact Artifact Type Code: S
content unspecified or combined
Doc Code: Artifact Artifact Type Code: U

Stapled Set(s) Color Documents or B/W Photographs:
Doc Code: Artifact Artifact Type Code: C

Microfilm(s)
Doc Code: Artifact Artifact Type Code: F

Video tape(s)
Doc Code: Artifact Artifact Type Code: V

Model(s)
Doc Code: Artifact Artifact Type Code: M

Bound Document(s):
Doc Code: Artifact Artifact Type Code: B

Confidential Information Disclosure Statement or Other Documents marked Proprietary, Trade Secrets, Subject to Protective Order, Material Submitted under MPEP 724.02, etc.
Doc Code: Artifact Artifact Type Code X

Other, description: **1 sheet of colored NPL (C16)**
Doc Code: Artifact Artifact Type Code: Z

March 8, 2004

ARTIFACT SHEET

Enter artifact number below. Artifact number is application number + artifact type code (see list below) + sequential letter (A, B, C ...). The first artifact folder for an artifact type receives the letter A, the second B, etc.. Examples: 59123456PA, 59123456PB, 59123456ZA, 59123456ZB

90/007317 UA (3/25/05)

Indicate quantity of a single type of artifact received but not scanned. Create individual artifact folder/box and artifact number for each Artifact Type.

- CD(s) containing:
- | | | |
|--|-------------------------------------|---|
| <input checked="" type="checkbox"/> computer program listing
Doc Code: Computer | <input type="checkbox"/> | Artifact Type Code: P |
| <input type="checkbox"/> pages of specification
and/or sequence listing
and/or table
Doc Code: Artifact | <input type="checkbox"/> | Artifact Type Code: S |
| <input type="checkbox"/> content unspecified or combined
Doc Code: Artifact | <input checked="" type="checkbox"/> | Artifact Type Code: U <u>(1 CD of References C33-C110)</u> |
- Stapled Set(s) Color Documents or B/W Photographs:
Doc Code: Artifact Artifact Type Code: C
- Microfilm(s)
Doc Code: Artifact Artifact Type Code: F
- Video tape(s)
Doc Code: Artifact Artifact Type Code: V
- Model(s)
Doc Code: Artifact Artifact Type Code: M
- Bound Document(s):
Doc Code: Artifact Artifact Type Code: B
- Confidential Information Disclosure Statement or Other Documents marked
Proprietary, Trade Secrets, Subject to Protective Order, Material Submitted under
MPEP 724.02, etc.
Doc Code: Artifact Artifact Type Code X
- Other, description:
Doc Code: Artifact Artifact Type Code: Z

March 8, 2004



UNITED STATES PATENT AND TRADEMARK OFFICE

UNITED STATES DEPARTMENT OF COMMERCE
United States Patent and Trademark Office
Address: COMMISSIONER FOR PATENTS
P.O. Box 1450
Alexandria, Virginia 22313-1450
www.uspto.gov

APPLICATION NO.	FILING DATE	FIRST NAMED INVENTOR	ATTORNEY DOCKET NO.	CONFIRMATION NO.
90/007,317	11/23/2004	6425035	HOESE1/WAB	1634
25094	7590	03/17/2005	EXAMINER	
DLA PIPER RUDNICK GRAY CARY US, LLP 2000 University Avenue E. Palo Alto, CA 94303-2248			Fleming, Fritz	
			ART UNIT	PAPER NUMBER
			2182	

DATE MAILED: 03/17/2005

Please find below and/or attached an Office communication concerning this application or proceeding.



**UNITED STATES DEPARTMENT OF COMMERCE
Patent and Trademark Office**

Address: ASSISTANT COMMISSIONER FOR PATENTS
Washington, D.C. 20231

APPLICATION NO./ CONTROL NO.	FILING DATE	FIRST NAMED INVENTOR / PATENT IN REEXAMINATION	ATTORNEY DOCKET NO.
90/007,317	11/23/2004	6425035	HOESE1/WAB

Larry E. Servin
WANG, HARTMANN & GIBBS, PC
1301 Dove Street, #1050
Newport Beach, CA 92660

EXAMINER

Fleming, Fritz

ART UNIT	PAPER
-----------------	--------------

2182

DATE MAILED: 03/17/05

Please find below and/or attached an Office communication concerning this application or proceeding.

Commissioner of Patents and Trademarks

CC: DLA PIPER RUDNICK GRAY CARY US, LLP
2000 University Avenue
E. Palo Alto, CA 94303-22489



**UNITED STATES DEPARTMENT OF COMMERCE
Patent and Trademark Office**

Address: ASSISTANT COMMISSIONER FOR PATENTS
Washington, D.C. 20231

APPLICATION NO./ CONTROL NO.	FILING DATE	FIRST NAMED INVENTOR / PATENT IN REEXAMINATION	ATTORNEY DOCKET NO.
90/007,317	11/23/2004	6425035	HOESE1/WAB

William A. Blake
JONES, TULLAR & COOPER, PC
P.O. Box 2226 Eads Station
Alexandria, VA 22202

EXAMINER

Fleming, Fritz

ART UNIT	PAPER
----------	-------

2182

DATE MAILED: 03/17/05

Please find below and/or attached an Office communication concerning this application or proceeding.

Commissioner of Patents and Trademarks

CC: DLA PIPER RUDNICK GRAY CARY US, LLP
2000 University Avenue
E. Palo Alto, CA 94303-2248



Steven R. Sprinkle)
Sprinkle Law Group)
1301 W. 25th Street)
Suite 408)
Austin, Texas 78705)

FOR OWNER

Larry E. Severin)
Wang, Hartmann & Gibbs, PC)
1301 Dove Street, #1050)
Newport Beach, California 92660)

**FOR FIRST THIRD PARTY
REQUESTER**

William A. Blake)
Jones, Tullar & Cooper, PC)
P.O. Box 2226 Eads Station)
Alexandria, Virginia 22202)

**FOR SECOND THIRD PARTY
REQUESTER**

In re Hoese et al.)
Reexamination Proceeding)
Control No. 90/007,125)
Filed: July 19, 2004)
For: U.S. Patent No. 6,425,035)

**DECISION *SUA SPONTE*,
MERGING REEXAMINATION
PROCEEDINGS**

In re Hoese et al.)
Reexamination Proceeding)
Control No. 90/007,317)
Filed: November 23, 2004)
For: U.S. Patent No. 6,425,035)

The above noted reexamination proceedings are before the Director of Technology Center 2100 for consideration of merger of the proceedings under 37 CFR § 1.565(c).

BACKGROUND

1. Patent No. 6,425,035 issued on July 23, 2002.

'7125 Proceeding

2. A first request for reexamination, Control No. 90/007,125 ('7125) was filed by the Third Party Requester on July 19, 2004.
3. Reexamination was ordered in the '7125 reexamination proceeding on September 22, 2004.
4. A Notification of litigation under 37 C.F.R. §1.565 filed by Patent Owner was received in the USPTO on December 13, 2004.
5. A Notification of concurrent proceedings under 37 C.F.R. §1.565 filed by Patent Owner was received in the USPTO on January 14, 2005.
6. A revocation and appointment of attorneys was filed on December 8, 2004.
7. A first Office action was mailed on February 7, 2005.
8. A Change of correspondence address for third party requester was filed on February 24, 2005.

'7317 Proceeding

9. A second request for reexamination, Control No. 90/007,317 ('7317) was filed by another Third Party Requester on November 23, 2004.
10. Reexamination was ordered in the '7317 reexamination proceeding on December 16, 2004.
11. A Notification of concurrent proceedings under 37 C.F.R. §1.565 filed by Patent Owner was received in the USPTO on January 14, 2005.

DISCUSSION

37 CFR § 1.565(c) states:

"If reexamination is ordered while a prior reexamination is pending, the reexamination proceedings will be consolidated and result in the issuance of a single certificate under section 1.570."

DECISION

I. Merger of Proceedings

In accordance with 37 CFR 1.565(c), the '7125 and '7317 reexamination proceedings are merged. The merged proceeding will be conducted in accordance with the following guidelines and requirements.

II. Requirement for Same Amendments in all Proceedings

The Patent Owner is required to maintain the same claims and specification in both files.

III. Conduct of Merged Proceeding

All papers mailed by the Office will take the form of a single action which applies to all proceedings. All papers issued by the Office or filed by the patent owner will contain the identifying data for both files and will be physically entered in each reexamination file. All papers filed by the patent owner must consist of a single response, filed in duplicate, each bearing an original signature, for entry into each file. All papers filed by the patent owner must be served on the requester and requester will be sent copies of all papers mailed by the Office.

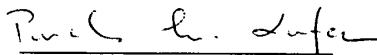

Pinchus M. Laufer
Special Programs Examiner
Technology Center 2100
Computer Architecture, Software, and Information Security
(571) 272-3599

cc: DLA Piper Rudnick Gray Cary US, LLP
Attn: Mark Berrier
2000 University Avenue
E. Palo Alto, California 94303-2248



REEXAM

IN THE UNITED STATES PATENT AND TRADEMARK OFFICE	
NOTIFICATION UNDER 37 C.F.R. 1.565	
Atty. Docket No. CROSS1123-19	
Applicant Geoffrey B. Hoese, et al.	
Application Number 90/007,317	Date Filed 11/23/2004
Title Storage Router and Method for Providing Virtual Local Storage	
Group Art Unit 2182	Examiner Fleming, Fritz, M.
Confirmation Number: 1634	

Commissioner for Patents
P.O. Box 1450
Alexandria, VA 22313-1450

Certificate of Mailing Under 37 C.F.R. §1.8

I hereby certify that this correspondence is being deposited with the United States Postal Service as First Class Mail in an envelope addressed to Commissioner for Patents, P.O. Box 1450, Alexandria, VA 22312-1450 on January 11, 2005

Janice Pampell
Janice Pampell

Dear Sir:

This notification is filed for the sole purpose to inform the Examiner of prior and concurrent litigation and reexamination proceedings involving United States Patent No. 6,425,035 (the "035 Patent") as required under 35 CFR 1.565. This is not and should not be construed as a submission under 35 CFR 1.530 as it does not discuss why the subject matter as claimed in these patents is not anticipated nor rendered obvious.

ONGOING LITIGATION AND CONCURRENT REEXAMINATION PROCEEDINGS

Currently, there is ongoing litigation in which Dot Hill Systems Corporation's ("Dot Hill") RAID controller products are accused of infringing and '035 Patent. See, *Crossroads Systems, Inc. v. Dot Hill Systems Corporation*, Western District of Texas, Case Number A-03-CV-754(SS). This litigation is pending.

Additionally, the '035 application is currently subject to reexamination under Reexamination Control No. 90/007,125.

This notification was served via first class mail on **January 7th, 2005** on William A. Blake, Jones, Tullar & Cooper, PC, P.O. Box 2266, Eads Station, Arlington, VA 22202.

Respectfully submitted,

Sprinkle IP Law Group
Attorneys for Applicant

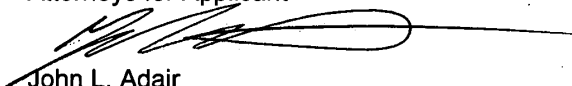
John L. Adair
Reg. No. 48,828

Date: January 7, 2005
1301 W. 25th Street
Suite 408
Austin, Texas 78705
Tel. (512) 637-9220
Fax. (512) 371-9088



IN THE UNITED STATES PATENT AND TRADEMARK OFFICE	
CERTIFICATE OF SERVICE UNDER 37 C.F.R. 1.248	
Atty. Docket No. CROSS1123-19	
Applicant Geoffrey B. Hoese, et al.	
Application Number 90/007,317	Date Filed 11/23/2004
Title Storage Router and Method for Providing Virtual Local Storage	
Group Art Unit 2182	Examiner Fleming, Fritz, M.
Confirmation Number: 1634	

Applicant hereby serves the Notification Under 37 C.F.R. 1.565 in the above referenced case to:

William A. Blake
Jones, Tullar & Cooper, PC
P.O. Box 2266
Eads Station
Arlington, VA 22202

As per 35 U.S.C. §1.248 service is made via first class mail on **January 7th, 2005.**

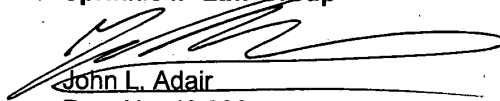

Respectfully submitted,

Sprinkle IP Law Group

John L. Adair
Reg. No. 48,828

Dated: January 7, 2005
1301 W. 25th Street, Suite 408
Austin, Texas 78705
Tel. (512) 637-9220
Fax. (512) 371-9088

Enclosures

 R examination 	Control No. 90/007,317	Applicant(s)
	Certificate Date	Certificate Number

<input type="checkbox"/> Requester	<input type="checkbox"/> Correspondence Address	<input type="checkbox"/> Patent Owner	<input checked="" type="checkbox"/> Third Party
<p>William A. Blake JONES, TULLAR & COOPER, PC P.O. Box 2266 Eads Station Arlington, VA 22202</p>			

LITIGATION REVIEW <input checked="" type="checkbox"/>	FME (examiner initials)	12/16/2004 (date)
	Case Name	Director Initials
	<i>Crossroads Systems (TX) Inc, A Texas Corporation, W. Dot Hill Systems Corp, a DE Corp, filed October 17, 2003, D. C. W. D. TEXAS, Doc. No. A-03-CA-754-55</i>	

PENDING OFFICE PROCEEDINGS	
TYPE OF PROCEEDING	NUMBER
1.	
2.	
3.	
4.	



UNITED STATES PATENT AND TRADEMARK OFFICE

UNITED STATES DEPARTMENT OF COMMERCE
United States Patent and Trademark Office
Address: COMMISSIONER FOR PATENTS
P.O. Box 1450
Alexandria, Virginia 22313-1450
www.uspto.gov

APPLICATION NO.	FILING DATE	FIRST NAMED INVENTOR	ATTORNEY DOCKET NO.	CONFIRMATION NO.
90/007,317	11/23/2004	6425035	HOESE1/WAB	1634
25094	7590	12/16/2004	EXAMINER	
GRAY, CARY, WARE & FREIDENRICH LLP 2000 University Avenue E. Palo Alto, CA 94303-2248			Fleming, Fritz M.	
			ART UNIT	PAPER NUMBER
			2182	

DATE MAILED: 12/16/2004

Please find below and/or attached an Office communication concerning this application or proceeding.

Order Granting / Denying Request For Ex Parte Reexamination	C ntr I No. 90/007,317	Patent Under Reexamination 6425035	
	Examiner Fritz M Fleming	Art Unit 2182	

--The MAILING DATE of this communication appears on the cover sheet with the correspondence address--

The request for *ex parte* reexamination filed 23 November 2004 has been considered and a determination has been made. An identification of the claims, the references relied upon, and the rationale supporting the determination are attached.

Attachments: a) PTO-892, b) PTO-1449, c) Other: _____

1. The request for *ex parte* reexamination is GRANTED.

RESPONSE TIMES ARE SET AS FOLLOWS:

For Patent Owner's Statement (Optional): TWO MONTHS from the mailing date of this communication (37 CFR 1.530 (b)). **EXTENSIONS OF TIME ARE GOVERNED BY 37 CFR 1.550(c).**

For Requester's Reply (optional): TWO MONTHS from the **date of service** of any timely filed Patent Owner's Statement (37 CFR 1.535). **NO EXTENSION OF THIS TIME PERIOD IS PERMITTED.** If Patent Owner does not file a timely statement under 37 CFR 1.530(b), then no reply by requester is permitted.

2. The request for *ex parte* reexamination is DENIED.

This decision is not appealable (35 U.S.C. 303(c)). Requester may seek review by petition to the Commissioner under 37 CFR 1.181 within ONE MONTH from the mailing date of this communication (37 CFR 1.515(c)). **EXTENSION OF TIME TO FILE SUCH A PETITION UNDER 37 CFR 1.181 ARE AVAILABLE ONLY BY PETITION TO SUSPEND OR WAIVE THE REGULATIONS UNDER 37 CFR 1.183.**

In due course, a refund under 37 CFR 1.26 (c) will be made to requester:

- a) by Treasury check or,
- b) by credit to Deposit Account No. _____, or
- c) by credit to a credit card account, unless otherwise notified (35 U.S.C. 303(c)).



Fritz M Fleming
Primary Examiner
Art Unit: 2182

cc:Requester (if third party requester)

Reexamination

1. A substantial new question of patentability affecting claims 1-14 of United States Patent Number 6,425,035 is raised by the request for *ex parte* reexamination.

Extensions of time under 37 CFR 1.136(a) will not be permitted in these proceedings because the provisions of 37 CFR 1.136 apply only to "an applicant" and not to parties in a reexamination proceeding. Additionally, 35 U.S.C. 305 requires that *ex parte* reexamination proceedings "will be conducted with special dispatch" (37 CFR 1.550(a)). Extensions of time in *ex parte* reexamination proceedings are provided for in 37 CFR 1.550(c).

- The threshold for determining whether or not to grant a re-examination is set forth in MPEP 2242, quoted below:

For "a substantial new question of patentability" to be present, it is only necessary that: (>A<) the prior art patents and/or printed publications raise a substantial question of patentability regarding at least one claim, i.e., the teaching of the (prior art) patents and printed publications is such that a reasonable examiner would consider the teaching to be important in deciding whether or not the claim is patentable; and (*>B<) the same question of patentability as to the claim has not been decided by the Office in a previous examination >or pending reexamination< of the patent or in a final holding of invalidity by the Federal Courts in a decision on the merits involving the claim. It is not necessary that a "prima facie" case of unpatentability exist as to the claim in order for "a substantial new question of patentability" to be present as to the claim. Thus, "a substantial new question of patentability" as to a patent claim could be present even if the examiner would not necessarily reject the claim as either fully anticipated by, or obvious in view of, the prior >art< patents or printed publications. As to the importance of the difference between "a substantial new question of patentability" and a "prima facie" case of unpatentability see generally In re Etter, 756 F.2d 852, 857 n.5, 225 USPQ 1, 4 n.5 (Fed. Cir. 1985).*

Thus it is clear, that a granting of a re-examination does not necessarily mean that a prima facie case of unpatentability exists, just that the teachings be important when deciding claim patentability.

- The manner in which the art is to be applied in the request is discussed in MPEP 2217, quoted below:

The third sentence of 35 U.S.C. 302 indicates that the "request must set forth the pertinency and manner of applying cited prior art to every claim for which reexamination is requested." 37 CFR 1.510(b)(2) requires that the request include "[a]n identification of every claim for which reexamination is requested, and a detailed explanation of the pertinency and manner of applying the cited prior art to every claim for which reexamination is requested." If the request is filed by the patent owner, the request for reexamination may also point out how claims distinguish over cited prior art.

Where substantial new questions of patentability are presented under 35 U.S.C. 102(f) or (g), the prior invention of another must be disclosed in a patent or printed publication. Substantial new questions of patentability may also be presented under 35 U.S.C. 103 which are based on the above indicated portions of 35 U.S.C. 102. Substantial new questions of patentability may be found under 35 U.S.C. 102(f) / 103 or 102(g) / 103 based on the prior invention of another disclosed in a patent or printed publication if the reference invention and the claimed invention were not commonly owned at the time the claimed invention was made. See, 35 U.S.C. 103(c) and MPEP § 706.02(I). See MPEP § 706.02(I)(1) for information pertaining to references which qualify as prior art under 35 U.S.C. 102(e)/103.

The mere citation of new patents or printed publications without an explanation does not comply with 37 CFR 1.510(b)(2). Requester must present an explanation of how the cited patents or printed publications are applied to all claims which requester considers to merit reexamination. This not only sets forth the requester's position to the Office, but also to the patent owner (where the patent owner is not the requester).

Given the above, requestor has, at a threshold minimum, provided a substantial new question of patentability via the citing of the InfoServer 100 System Operations Guide. Per the submitted document, such qualifies as a competent reference, given its publication date of 1990. Page 1-1 does clearly state that the InfoServer 100 is a virtual disk server that is not a file server, thereby not imposing a file system on the virtual disks and allowing each host system to use its own native file system. Page 1-2 does explicitly mention that a single disk can be subdivided into several partitions, each of which can be served to the network independently, while appearing to be whole disks to remote client systems and be used as though they were local hard disks. Per Figure 1-3, the InfoServer is connected on one hand to the ETHERNET (a LAN network) and on the other hand to the CDs (with SCSI-A/B busses per page 2-7). Partitions are created per page 3-8. LAD and LAST protocols are discussed at page 2-2, even though the LAST protocol does not provide any routing functions and uses multicast address feature to establish connections to the disks. Service is created per page 3-10 with the ability to select NOPASSWORD. Furthermore, the LANCE document sets forth on-chip DMA, as further shown in Johnson. However, the photos per InfoServer 150VXT (the other reference is the InfoServer 150 and not InfoServer 150VXT, difference not elaborated by requestor), are of such quality as to not clearly show anything, much less the Am7990 chip, as such is simply not clearly discernable. The DP5380 chip material does show an intent to couple with a DMA controller. Thus the above teachings were not present in the prosecution of the application that became the Hoese et al. Patent 6,425,035 and there is a further substantial likelihood that a reasonable examiner would

Art Unit: 2182

consider these teachings important in deciding whether or not the claims are patentable.

Accordingly, the InfoServer 100 publication raises a substantial new question of patentability as to claims 1-14, which question has not been decided in a previous examination of the Hoese et al. Patent. Thus claims 1-14 will be re-examined.

2. The patent owner is reminded of the continuing responsibility under 37 CFR 1.565(a) to apprise the Office of any litigation activity, or other prior or concurrent proceeding, involving Patent No. 6,425,035 throughout the course of this reexamination proceeding. The third party requester is also reminded of the ability to similarly apprise the Office of any such activity or proceeding throughout the course of this reexamination proceeding. See MPEP §§ 2207, 2282 and 2286.

3. Any inquiry concerning this communication or earlier communications from the examiner should be directed to Fritz M Fleming whose telephone number is 703-308-1483. The examiner can normally be reached on M-F, 0600-1500.

If attempts to reach the examiner by telephone are unsuccessful, the examiner's supervisor, Jeffrey Gaffin can be reached on 703-308-3301. The fax phone number for the organization where this application or proceeding is assigned is 703-872-9306.

Information regarding the status of an application may be obtained from the Patent Application Information Retrieval (PAIR) system. Status information for published applications may be obtained from either Private PAIR or Public PAIR. Status information for unpublished applications is available through Private PAIR only. For more information about the PAIR system, see <http://pair-direct.uspto.gov>. Should you have questions on access to the Private PAIR system, contact the Electronic Business Center (EBC) at 866-217-9197 (toll-free).

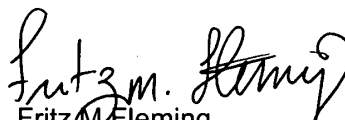
Fritz M. Fleming
Primary Examiner
Art Unit 2182

fmf

RICHARD M. LAIFER, PH.D.
SPECIAL PROGRAM EXAMINER
TECHNOLOGY CENTER 2100

Under the Paperwork Reduction Act of 1995, no persons are required to respond to a collection of information unless it contains a valid OMB control number.

Substitute for form 1449B/PTO		Complete if Known	
INFORMATION DISCLOSURE STATEMENT BY APPLICANT <i>(Use as many sheets as necessary)</i>		Application Number	Patent No. 6,425,035
		Filing Date	Issue Date 07/23/2002
		First Named Inventor	HOESE
		Art Unit	2182
		Examiner Name	FLEMING, FRITZ M.
		Attorney Docket Number	HOESE1WAB
Sheet	1	of	1

NON PATENT LITERATURE DOCUMENTS			
Examiner Initials*	Cite No. ¹	Include name of the author (in CAPITAL LETTERS), title of the article (when appropriate), title of the item (book, magazine, journal, serial, symposium, catalog, etc.), date, page(s), volume-issue number(s), publisher, city and/or country where published.	T ²
F.F.	1	"InfoServer 100 System Operations Guide", First Edition, Digital Equipment Corporation, 1990	
F.F.	2	S.P. Joshi, "Ethernet controller chip interfaces with variety of 16-bit processors," Electronic Design, Hayden Publishing Co., Inc., Rochelle Park, NJ, Oct. 14, 1982. pp193-200	
F.F.	3	"DP5380 Asynchronous SCSI Interface", National Semiconductor Corporation, Arlington, TX, May 1989, pp. 1-32	
F.F.	4	Johnson, D.B., et al., "The Peregrine High Performance RPC System", Software--Practice & Experience, 23(2):201-221, Feb. 1993	
F.F.	5	"InfoServer 150--Installation and Owner's Guide", EK-INFSV-OM-001, Digital Equipment Corporation, Maynard, Massachusetts 1991, Chapters 1 and 2	
F.F.	6	Pictures of internal components of the InfoServer 150, taken from http://www.binarydinosaurs.couk/Museum/Digital/infoserver/infoserver.php in Nov. 2004	

Examiner Signature	<i>Fritz M. Fleming</i>	Date Considered	12/16/2004
--------------------	-------------------------	-----------------	------------

*EXAMINER: Initial if reference considered, whether or not citation is in conformance with MPEP 609. Draw line through citation if not in conformance and not considered. Include copy of this form with next communication to applicant.
¹Applicant's unique citation designation number (optional). ²Applicant is to place a check mark here if English language Translation is attached.
 This collection of information is required by 37 CFR 1.97 and 1.98. The information is required to obtain or retain a benefit by the public which is to file (and by the USPTO to process) an application. Confidentiality is governed by 35 U.S.C. 122 and 37 CFR 1.14. This collection is estimated to take 2 hours to complete, including gathering, preparing, and submitting the completed application form to the USPTO. Time will vary depending upon the individual case. Any comments on the amount of time you require to complete this form and/or suggestions for reducing this burden should be sent to the Chief Information Officer, U.S. Patent and Trademark Office, U.S. Department of Commerce, P.O. Box 1450, Alexandria, VA 22313-1450. DO NOT SEND FEES OR COMPLETED FORMS TO THIS ADDRESS. SEND TO: Commissioner for Patents, P.O. Box 1450, Alexandria, VA 22313-1450.

If you need assistance in completing the form, call 1-800-PTO-9199 and select option 2.

1 of 1 DOCUMENT

UNITED STATES PATENT AND TRADEMARK OFFICE GRANTED PATENT

6425035

Link to Claims Section

July 23, 2002

Storage router and method for providing virtual local storage

REEXAM-LITIGATE: July 19, 2004 - Reexamination requested by Natu J. Patel, Wang & Patel, Reexamination No. 90/007,125 (O.G. August 31, 2004) Ex. Gp: 2111

NOTICE OF LITIGATION

Crossroads Systems (Texas), Inc., a Texas Corporation v. Dot Hill Systems Corporation, a Delaware corporation, Filed October 17, 2003, D.C. W.D. Texas, Doc. No. A-03-CA-754-55

INVENTOR: Hoese, Geoffrey B. - Austin, Texas; Russell, Jeffry T. - Cibolo, Texas

CERT-CORRECTION: August 26, 2003 - a Certificate of Correction was issued for this patent (O.G. September 16, 2003)

APPL-NO: 965335 (09)

FILED-DATE: September 27, 2001

GRANTED-DATE: July 23, 2002

ASSIGNEE-AT-ISSUE: Crossroads Systems, Inc., Austin, Texas, 02

ENGLISH-ABST:

A storage router (56) and storage network (50) provide virtual local storage on remote SCSI storage devices (60, 62, 64) to Fiber Channel devices. A plurality of Fiber Channel devices, such as workstations (58), are connected to a Fiber Channel transport medium (52), and a plurality of SCSI storage devices (60, 62, 64) are connected to a SCSI bus transport medium (54). The storage router (56) interfaces between the Fibre Channel transport medium (52) and the SCSI bus transport medium (54). The storage router (56) maps between the workstations (58) and the SCSI storage devices (60, 62, 64) and implements access controls for storage space on the SCSI storage devices (60, 62, 64). The storage router (56) then allows access from the workstations (58) to the SCSI storage devices (60, 62, 64) using native low level, block protocol in accordance with the mapping and the access controls.

LEXIS-NEXIS
Library: PATENTS
File: ALL

No Documents Found!

No documents were found for your search (6,425,035 or 6425035). Click the "Edit Search" button below to try again. You may want to try one or more of the following:

- Check for spelling errors.
- Remove some search terms.
- Use a less restrictive date range.
- Use more common search terms. "Suggested Words and Concepts" are displayed on the search form when you click on Edit Search.

[Edit Search](#)

[About LexisNexis](#) | [Terms and Conditions](#)

Copyright © 2004 LexisNexis, a division of Reed Elsevier Inc. All rights reserved.

LEXIS-NEXIS
Library: PATENTS
File: CASES

No Documents Found!

No documents were found for your search (6,425,035 r 6425035).
Click the "Edit Search" button below to try again. You may want to try one or more of the following:

- Check for spelling errors.
- Remove some search terms.
- Use a less restrictive date range.
- Use more common search terms. "Suggested Words and Concepts" are displayed on the search form when you click on Edit Search.

[Edit Search](#)

[About LexisNexis](#) | [Terms and Conditions](#)

Copyright © 2004 LexisNexis, a division of Reed Elsevier Inc. All rights reserved.

LEXIS-NEXIS
Library: PATENTS
File: JNLS

1 of 2 DOCUMENTS

Copyright 2003 Comtex News Network, Inc.
All Rights Reserved
Copyright 2003 Knobias.com, LLC, All rights reserved.
Knobias.com

This content is provided to LexisNexis by Comtex News Network, Inc.

October 22, 2003 Wednesday

LENGTH: 74 words

HEADLINE: CRDS Files Patent Infringement Suit Against HILL

DATELINE: Ridgeland, MS

BODY:

...Crossroads Systems Inc. (CRDS) on October 17, 2003. Dot Hill has not been served with the Complaint. The suit alleges patent infringement by Dot Hill of United States Patent Nos. 5,941,972 and 6,425,035, relating to storage routers and methods for providing virtual local storage.

LEXIS-NEXIS
Library: NEWS
File: CURNEWS

2 of 2 DOCUMENTS

Copyright 2003 PR Newswire Association, Inc.
PR Newswire

October 22, 2003 Wednesday

SECTION: FINANCIAL NEWS

LENGTH: 446 words

HEADLINE: Dot Hill Systems Announces Complaint Filed By Crossroads Systems

DATELINE: CARLSBAD, Calif. Oct. 22

BODY:

...Texas by Crossroads Systems on October 17, 2003. Dot Hill has not been served with the Complaint. The suit alleges patent infringement by Dot Hill of United States Patent Nos. 5,941,972 and 6,425,035, relating to storage routers and methods for providing virtual local storage.

?us6425035/pn

** SS 1: Results 1

Search statement 2

?prt full nonstop legalall

1/1 PLUSPAT - (C) QUESTEL-ORBIT- image
PN - US2002010812 A1 20020124 [US20020010812]
PN2 - US6425035 B2 20020723 [US6425035]
TI - (A1) Storage router and method for providing virtual local storage
PA - (B2) CROSSROADS SYSTEMS INC (US)
PA0 - Crossroads Systems, Inc., Austin TX [US]
PA2 - (B2) CROSSROADS SYSTEMS INC (US)
IN - (A1) HOESE GEOFFREY B (US); RUSSELL JEFFRY T (US)
AP - US96533501 20010927 [2001US-0965335]
FD - Continuation of: US5941972
PR - US96533501 20010927 [2001US-0965335]
- US35468299 19990715 [1999US-0354682]
- US179997 19971231 [1997US-0001799]
IC - (A1) G06F-003/00
EC - G06F-013/40D2
PCL - ORIGINAL (O) : 710105000; CROSS-REFERENCE (X) : 710008000 710036000
710310000
DT - Corresponding document
CT - US5748924; US5768623; US5809328; US5812754; US5835496; US5848251;
US5935260; US5941972; US5959994; US6041381; US6055603; US6065087;
US6075863; US6098149; US6118766; US6148004; US6185203; US6209023;
US6230218; US6341315; US6343324
STG - (A1) Utility Patent Application published on or after January 2, 2001
STG2- (B2) U.S. Patent (with pre-grant pub.) after Jan. 2, 2001
AB - A storage router (56) and storage network (50) provide virtual local
storage on remote SCSI storage devices (60, 62, 64) to Fiber Channel
devices. A plurality of Fiber Channel devices, such as workstations
(58), are connected to a Fiber Channel transport medium (52), and a
plurality of SCSI storage devices (60, 62, 64) are connected to a SCSI
bus transport medium (54). The storage router (56) interfaces between
the Fibre Channel transport medium (52) and the SCSI bus transport
medium (54). The storage router (56) maps between the workstations
(58) and the SCSI storage devices (60, 62, 64) and implements access
controls for storage space on the SCSI storage devices (60, 62, 64).
The storage router (56) then allows access from the workstations (58)
to the SCSI storage devices (60, 62, 64) using native low level, block
protocol in accordance with the mapping and the access controls.
UP - 2002-05

1/1 LGST - (C) EPO
PN - US2002010812 A1 20020124 [US20020010812]
- US6425035 B2 20020723 [US6425035]
AP - US96533501 20010927 [2001US-0965335]
ACT - 20030826 US/CC-A
CERTIFICATE OF CORRECTION
- 20040831 US/RR-A [+]
REQUEST FOR REEXAMINATION FILED
EFFECTIVE DATE: 20040719
UP - 2004-37

1/1 CRXX - (C) CLAIMS/RRX
PN - 6,425,035 A 20020723 [US6425035]

PA - Crossroads Systems Inc
ACT - 20040719 REEXAMINATION REQUESTED
ISSUE DATE OF O.G.: 20040831
REEXAMINATION REQUEST NUMBER: 90/007125
Natu J. Patel, Wang & Patel, Newport Beach, CA



UNITED STATES PATENT AND TRADEMARK OFFICE

UNITED STATES DEPARTMENT OF COMMERCE
United States Patent and Trademark Office
Address: COMMISSIONER FOR PATENTS
P.O. Box 1450
Alexandria, Virginia 22313-1450
www.uspto.gov

REEXAM CONTROL NUMBER	FILING OR 371 (c) DATE	PATENT NUMBER
90/007,317	11/23/2004	6425035

CONFIRMATION NO. 1634



William A Blake
JONES TULLAR & COOPER, PC
P.O. Box 2266 Eads Station
Arlington, VA 22202

Date Mailed: 12/10/2004

NOTICE OF REEXAMINATION REQUEST FILING DATE

(Third Party Requester)

Requester is hereby notified that the filing date of the request for reexamination is 11/23/2004, the date the required fee of \$2,520 was received.

A decision on the request for reexamination will be mailed within three months from the filing date of the request for reexamination. (See 37 CFR 1.515(a)).

A copy of the Notice is being sent to the person identified by the requester as the patent owner. Further patent owner correspondence will be the latest attorney or agent of record in the patent file. (See 37 CFR 1.33). Any paper filed should include a reference to the present request for reexamination (by Reexamination Control Number).

cc: Patent Owner

25094
GRAY, CARY, WARE & FREIDENRICH LLP
2000 University Avenue
E. Palo Alto, CA 94303-2248

Mad Suh
Office of Patent Legal Administration
Central Reexamination Unit ((571) 272-7750; FAX (571)273-0100
PART 3 - OFFICE COPY



UNITED STATES PATENT AND TRADEMARK OFFICE

UNITED STATES DEPARTMENT OF COMMERCE
 United States Patent and Trademark Office
 Address: COMMISSIONER FOR PATENTS
 P.O. Box 1450
 Alexandria, Virginia 22313-1450
 www.uspto.gov

REEXAM CONTROL NUMBER	FILING OR 371 (e) DATE	PATENT NUMBER
90/007,317	11/23/2004	6425035

25094
 GRAY, CARY, WARE & FREIDENRICH LLP
 2000 University Avenue
 E. Palo Alto, CA 94303-2248

CONFIRMATION NO. 1634

REEXAM ASSIGNMENT NOTICE



OC000000014721174

Date Mailed: 12/10/2004

NOTICE OF ASSIGNMENT OF REEXAMINATION REQUEST

The above-identified request for reexamination has been assigned to Art Unit 2111. All future correspondence to the proceeding should be identified by the control number listed above and directed to the assigned Art Unit.

A copy of this Notice is being sent to the latest attorney or agent of record in the patent file or to all owners of record. (See 37 CFR 1.33(c)). If the addressee is not, or does not represent, the current owner, he or she is required to forward all communications regarding this proceeding to the current owner(s). An attorney or agent receiving this communication who does not represent the current owner(s) may wish to seek to withdraw pursuant to 37 CFR 1.36 in order to avoid receiving future communications. If the address of the current owner(s) is unknown, this communication should be returned within the request to withdraw pursuant to Section 1.36.

cc: Third Party Requester(if any)

William A Blake
 JONES TULLAR & COOPER, PC
 P.O. Box 2266 Eads Station
 Arlington, VA 22202

Mad Sule

Office of Patent Legal Administration
 Central Reexamination Unit (571) 272-7750; FAX (571)273-0100

PARTS - OFFICE COPY

Patent Assignment Abstract of Title

Total Assignments: 3

Application #: 09001799 **Filing Dt:** 12/31/1997 **Patent #:** 5941972 **Issue Dt:** 08/24/1999

PCT #: NONE

Publication #: NONE

Pub Dt:

Inventors: GEOFFREY B. HOESE, JEFFRY T. RUSSELL

Title: STORAGE ROUTER AND METHOD FOR PROVIDING VIRTUAL LOCAL STORAGE

Assignment: 1

Reel/Frame: <u>008929/0290</u>	Received: 02/06/1998	Recorded: 12/31/1997	Mailed: 03/19/1998	Pages: 4
---------------------------------------	--------------------------------	--------------------------------	------------------------------	--------------------

Conveyance: ASSIGNMENT OF ASSIGNORS INTEREST (SEE DOCUMENT FOR DETAILS).

Assignors: HOESE, GEOFFREY B.

Exec Dt: 12/22/1997

RUSSELL, JEFFRY T.

Exec Dt: 12/22/1997

Assignee: CROSSROADS SYSTEMS, INC.

9390 RESEARCH BLVD., SUITE II-300
AUSTIN, TEXAS 78759

Correspondent: BAKER & BOTTS, L.L.P.

ANTHONY E. PETERMAN
2001 ROSS AVENUE
DALLAS, TX 75201-2980

Assignment: 2

Reel/Frame: <u>011284/0218</u>	Received: 12/05/2000	Recorded: 11/16/2000	Mailed: 02/05/2001	Pages: 8
---------------------------------------	--------------------------------	--------------------------------	------------------------------	--------------------

Conveyance: SECURITY AGREEMENT

Assignor: CROSSWORLDS SOFTWARE, INC.

Exec Dt: 06/30/2000

Assignee: SILICON VALLEY BANK

LOAN DOCUMENTATION HG150
3003 TASMAN DR
SANTA CLARA, CALIFORNIA 95054

Correspondent: SILICON VALLEY BANK

JACQUELYN LE
LOAN DOCUMENTATION HG150
3003 TASMAN DR.
SANTA CLARA, CA 95054

Assignment: 3

Reel/Frame: <u>012785/0083</u>	Received: 04/17/2002	Recorded: 04/03/2002	Mailed: 06/12/2002	Pages: 2
---------------------------------------	--------------------------------	--------------------------------	------------------------------	--------------------

Conveyance: RELEASE

Assignor: SILICON VALLEY BANK

Exec Dt: 03/20/2002

Assignee: CROSSWORLDS SOFTWARE

577 AIRPORT BOULEVARD, SUITE 300
BURLINGAME, CALIFORNIA 94010

Correspondent: SILICON VALLEY BANK

MICHELLE GIANNINI
LOAN DOCUMENTATION HA155
3003 TASMAN DR.
SANTA CLARA, CALIFORNIA 95054

If you have any comments or questions concerning the data displayed, contact OPR / Assignments at 703-308-9723
Web interface last modified: Oct. 5, 2002

Reexam #

PTO/SB/57 (09-04)
Approved for use through 04/30/2007. OMB 0651-0033
U.S. Patent and Trademark Office; U.S. DEPARTMENT OF COMMERCE

Under the Paperwork Reduction Act of 1995, no persons are required to respond to a collection of information unless it displays a valid OMB control number.
(Also referred to as FORM PTO-1465)

REQUEST FOR EX PARTE REEXAMINATION TRANSMITTAL FORM

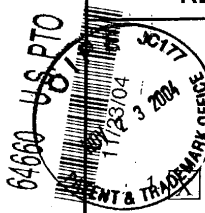

Address to:
Mail Stop Ex Parte Reexam
Commissioner for Patents
P.O. Box 1450
Alexandria, VA 22313-1450

Attorney Docket No.: HOESE1/WAB

Date: 11/23/2004

This is a request for *ex parte* reexamination pursuant to 37 CFR 1.510 of patent number 6,425,035 issued 07/23/2002. The request is made by:

patent owner. third party requester.

64660 U.S. PTO
90007317



2. The name and address of the person requesting reexamination is:

William A. Blake, Jones, Tullar & Cooper, PC

P.O. Box 2266 Eads Station

Arlington, VA 22202

3. a. A check in the amount of \$2,520.00 is enclosed to cover the reexamination fee, 37 CFR 1.20(c)(1);

b. The Director is hereby authorized to charge the fee as set forth in 37 CFR 1.20(c)(1) to Deposit Account No. (submit duplicative copy for fee processing); or

c. Payment by credit card. Form PTO-2038 is attached.

4. Any refund should be made by check or credit to Deposit Account No. 37 CFR 1.26(c). If payment is made by credit card, refund must be to credit card account.

5. A copy of the patent to be reexamined having a double column format on one side of a separate paper is enclosed. 37 CFR 1.510(b)(4)

6. CD-ROM or CD-R in duplicate, Computer Program (Appendix) or large table
 Landscape Table on CD

7. Nucleotide and/or Amino Acid Sequence Submission
If applicable, items a. - c. are required.

a. Computer Readable Form (CRF)
b. Specification Sequence Listing on:

i. CD-ROM (2 copies) or CD-R (2 copies); or
ii. paper

c. Statements verifying identity of above copies

8. A copy of any disclaimer, certificate of correction or reexamination certificate issued in the patent is included.

9. Reexamination of claim(s) 1-14 is requested.

10. A copy of every patent or printed publication relied upon is submitted herewith including a listing thereof on Form PTO/SB/08, PTO-1449, or equivalent. 12/06/2004 MSALDANA 00000008 90007317

11. An English language translation of all necessary and pertinent non-English language patents and/or printed publications is included.

[Page 1 of 2]

This collection of information is required by 37 CFR 1.510. The information is required to obtain or retain a benefit by the public which is to file (and by the USPTO to process) an application. Confidentiality is governed by 35 U.S.C. 122 and 37 CFR 1.11 and 1.14. This collection is estimated to take 2 hours to complete, including gathering, preparing, and submitting the completed application form to the USPTO. Time will vary depending upon the individual case. Any comments on the amount of time you require to complete this form and/or suggestions for reducing this burden, should be sent to the Chief Information Officer, U.S. Patent and Trademark Office, U.S. Department of Commerce, P.O. Box 1450, Alexandria, VA 22313-1450. DO NOT SEND FEES OR COMPLETED FORMS TO THIS ADDRESS. SEND TO: Mail Stop Ex Parte Reexam, Commissioner for Patents, P.O. Box 1450, Alexandria, VA 22313-1450.

If you need assistance in completing the form, call 1-800-PTO-9199 and select option 2.

Under the Paperwork Reduction Act of 1995, no persons are required to respond to a collection of information unless it displays a valid OMB control number.

12. The attached detailed request includes at least the following items:

a. A statement identifying each substantial new question of patentability based on prior patents and printed publications. 37 CFR 1.510(b)(1)

b. An identification of every claim for which reexamination is requested, and a detailed explanation of the pertinency and manner of applying the cited art to every claim for which reexamination is requested. 37 CFR 1.510(b)(2)

13. A proposed amendment is included (only where the patent owner is the requester). 37 CFR 1.510(e)

14. a. It is certified that a copy of this request (if filed by other than the patent owner) has been served in its entirety on the patent owner as provided in 37 CFR 1.33(c).
 The name and address of the party served and the date of service are:

Steven Sprinkle

Sprinkle IP Law Group, PO Box 684767

Austin, TX, 78768-4767

Date of Service: November 23, 2004; or

b. A duplicate copy is enclosed since service on patent owner was not possible.

15. Correspondence Address: Direct all communication about the reexamination to:

The address associated with Customer Number:

OR

Firm or Individual Name William A. Blake

Address Jones, Tullar & Cooper, PC
P.O. Box 2266 Eads Station

City	<u>Arlington</u>	State	<u>VA</u>	Zip	<u>22202</u>
Country					
Telephone	<u>703-415-1500</u>	Fax	<u>703-415-1508</u>		

16. The patent is currently the subject of the following concurrent proceeding(s):

a. Copending reissue Application No. _____

b. Copending reexamination Control No. 90/007,125

c. Copending Interference No. _____

d. Copending litigation styled: _____

Crossroads Systems, Inc. v. Dot Hill Systems Corporation, USDC for Western District of
Texas, Case No. A-03-CV-754(SS)

WARNING: Information on this form may become public. Credit card information should not be included on this form. Provide credit card information and authorization on PTO-2038.

William A. Blake
 Authorized Signature

11-23-2004
 Date

William A. Blake
 Typed/Printed Name

30548
 Registration No.

For Patent Owner Requester
 For Third Party Requester

IN THE UNITED STATES PATENT AND TRADEMARK OFFICE

Patent No. : 6,425,035
Date of Issue : July 23, 2002
Name of Patentee : Geoffrey B. Hoese et al.
Title of Invention : STORAGE ROUTER AND METHOD FOR PROVIDING
VIRTUAL LOCAL STORAGE

Mail Stop Ex Parte Reexam
Commissioner for Patents
P.O. Box 1450
Alexandria, VA 22313-1450

REQUEST FOR REEXAMINATION
[35 U.S.C. §302 et seq., 37 C.F.R. §1.510]

Sir:

Reexamination under 35 U.S.C. §§302-307 and 37 C.F.R §1.510 is requested of United States Patent No. 6,425,035, which issued on July 23, 2002, to Geoffrey B. Hoese and Jeffrey T. Russell (hereinafter "Hoese").

At least one request for reexamination has recently been granted for the above-referenced Hoese patent, this being Reexamination Control No. 90/007,125 filed July 19, 2004 (the "Pending Request"). Since the Pending Request has just recently been granted less than 60 days ago, it is believed proper to merge the present request with it. See MPEP §2283 and 37 C.F.R §1.565.

I. Claims For Which Reexamination Is Requested

Reexamination is requested of claims 1-14 (all claims) of the Hoese patent in view of the following prior art publications. These publications are listed in the attached Form PTO/SB/08B and copies of each are enclosed:

- 1) "InfoServer 100 System Operations Guide," First Edition, Digital Equipment Corporation, 1990 (hereinafter "IS100");
- 2) S. P. Joshi, "Ethernet controller chip interfaces with variety of 16-bit processors," *Electronic Design*, Hayden Publishing Company, Inc., Rochelle Park, NJ, October 14, 1982, pp. 193-200 (hereinafter "LANCE"); and
- 3) "DP5380 Asynchronous SCSI Interface", National Semiconductor Corporation, Arlington, TX, May 1989, pp. 1-32 (hereinafter "DP5380")

In addition, the following documents are submitted in support of the arguments made for obviousness under 35 U.S.C. §103. These documents are also listed in the attached Form PTO/SB/08B:

- 4) Johnson, D.B., et al., "The Peregrine High Performance RPC System," *Software -- Practice & Experience* , 23(2):201-221, February 1993 (hereinafter "Johnson")
- 5) "InfoServer 150 -- Installation and Owner's Guide", EK-INFSV-OM-001, Digital Equipment Corporation, Maynard, Massachusetts 1991, chapters 1 and 2 (hereinafter "IS150 Manual").
- 6) Pictures of internal components of the InfoServer 150, taken from <http://www.binarydinosaurs.co.uk/Museum/Digital/infoserver/infoserver.php> (hereinafter "IS150 Photos") in November 2004.

II. Substantial New Questions Of Patentability Raised By The Newly Cited Prior Art (37 C.F.R 1.510(b)(1))

The following substantial new questions of patentability are raised by the newly cited prior art documents. These documents have not been previously made of record either during the prosecution of the Hoese patent or in the Pending Request. A detailed analysis of each new question of patentability is set forth in the next section.

A. Claims 1-4, 7-9 and 11-14 of Hoese are unpatentable 35 U.S.C. §102 as being fully anticipated under by the prior art IS100 document.

B. Claim 5 of Hoese is unpatentable under 35 U.S.C. §103 as being obvious over the IS100 prior art document in view of the LANCE document.

C. Claim 6 is unpatentable under 35 U.S.C. §103 as being obvious over the IS100 prior art document in view of the DP5380 document.

D. Claim 10 of Hoese is unpatentable under 35 U.S.C. §103 as being obvious over the prior art documents IS100, LANCE and DP5380.

III. Detailed Explanation Of The Pertinency Of The Cited Prior Art (37 C.F.R. §1.510(b) (2))

A. Claims 1-4, 7-9 and 11-14 of Hoese are fully anticipated under 35 U.S.C. §102 by the prior art IS100 document. Claims 1-4, 7-9 and 11-14 are set forth in the charts that follow with an explanation as to how the IS100 document meets all the recited claim elements.

<p>“1. A storage router for providing virtual local storage on remote storage devices to devices, comprising:”</p>	<p>(IS100 at p.1-1 describes the Digital Equipment Corporation (DEC) InfoServer 100 as a "virtual disk server" that serves sets of logical blocks to an Ethernet network-connected server. It is also said at pp. 2-1 to 2-2 of IS100 that the InfoServer 100 provides "access to the virtual disks it serves to the local-area network (LAN) via the Local Area Disk (LAD) and Local Area Storage Transport (LAST) protocols".)</p>
<p>“a buffer providing memory work space for the storage router;”</p>	<p>(IS100 at p.3-64 refers to a "pool" of memory whose pool size is displayed on request and that the pool being memory is made available to the running software, for use in serving disks.)</p>
<p>“a first controller operable to connect to and interface with a first transport medium;”</p>	<p>(IS100 at p.1-3 shows the InfoServer 100 connected to an Ethernet LAN segment, thus the InfoServer 100 inherently had an Ethernet Network Interface Controller (NIC). The InfoServer 100 also responded to commands such as SHOW ETHERNET which display the status and traffic statistics for the Ethernet interface. See IS100 p.3-47.)</p>
<p>“a second controller operable to connect to and interface with a second transport medium; and”</p>	<p>(IS100 at pp. 2-7 and 2-8 refer to two SCSI buses, one internal and one external. Pp. 3-44 through 3-46 of IS100 describe a SHOW DEVICE command which displays the status of storage devices attached to the IS100 via the SCSI buses.)</p>
<p>“a supervisor unit coupled to the first controller, the second controller and the buffer, the supervisor unit operable”</p>	<p>(The InfoServer 100 provided connectivity between an Ethernet interface and disks connected to a interface. See IS100 p.1-1 and Fig. 1-1.)</p>
<p>“to map between devices connected to the first transport medium and the storage devices,”</p>	<p>(The storage space of the storage devices is addressed as "partitions" through the CREATE PARTITION command. See IS100 pp. 3-7 and 3-8. The partitions are mappings from a partition name to portions of the storage devices.)</p>
<p>“to implement access controls for storage space on the storage devices and”</p>	<p>(The devices or partitions are then made available to connected devices as "SERVICES" via the CREATE SERVICE</p>

	command which includes an optional "access control password". See IS100 p. 3-10. The password feature thus serves as an access control.)
"to process data in the buffer to interface between the first controller and the second controller"	(The "pool" is used for servicing disk requests that originate from the network. See IS100 p.3-64.)
"to allow access from devices connected to the first transport medium to the storage devices using native low level, block protocols."	(At IS100 p. 1-1 it is said that each host can use its own "native file system" to access the InfoServer 100. In particular, the LAD protocol provides a mechanism for reading and writing logical disk blocks independent from any underlying file system. See also IS100 p. 2-2.)

Hoese, claim 2

IS100

"2. The storage router of claim 1, wherein the supervisor unit maintains an allocation of subsets of storage space to associated devices connected to the first transport medium, wherein each subset is only accessible by the associated device connected to the first transport medium."	(The InfoServer 100 partitions maintain a mapping between portions of the storage space and the partition name. Each service is accessible only to clients that have access to the associated password. A particular service can also be restricted to a single client at a time. See IS100 pp. 3-9 through 3-12, "READERS" and "WRITERS" parameters, for example.)
---	---

Hoese, claim 3

IS100

"3. The storage router of claim 2, wherein the devices connected to the first transport medium comprise workstations."	(Workstations as well as PCs and VAXes are connected are to the Ethernet port on the InfoServer 100. See IS100, Figure 1-1 on p. 1-3.)
--	--

Hoese, claim 4

IS100

"4. The storage router of claim 2, wherein the storage devices comprise hard disk drives."	(IS100 at p. 3-45 illustrates an example of the output of the "SHOW DEVICE" command -- note that the output is a list of connected devices that includes "hard disk" drives.)
--	---

<p>“7. A storage network, comprising:”</p> <p>“a first transport medium;”</p> <p>“a second transport medium;”</p> <p>“a plurality of workstations connected to the first transport medium;”</p>	<p>(Similar to claim 1.</p> <p>IS100 at p.1-3 shows the InfoServer 100 connected to an Ethernet LAN segment, thus the InfoServer 100 inherently had an Ethernet Network Interface Controller (NIC). The InfoServer 100 also responded to commands such as SHOW ETHERNET which display the status and traffic statistics for the Ethernet interface. See IS100 p.3-47.</p> <p>IS100 at pp. 2-7 and 2-8 refer to two SCSI buses, one internal and one external. IS100 at pp. 3-44 through 3-46 of IS100 describe a SHOW DEVICE command which displays the status of devices attached to the IS100 via the SCSI buses.</p> <p>Workstations as well as PCs and VAXes are connected are to the Ethernet port on the InfoServer 100. See IS100, Figure 1-1 on p. 1-3.)</p>
<p>“a plurality of storage devices connected to the second transport medium; and”</p>	<p>(Figure 1-1 on p. 1-3 of IS100 shows multiple disks connected to the InfoServer 100 -- see also the example output from the SHOW DEVICE command at IS100 p.3-45 showing that multiple disks devices are connected.)</p>
<p>“a storage router interfacing between the first transport medium and the second transport medium, the storage router providing virtual local storage on the storage devices to the workstations and operable:”</p>	<p>(Similar to claim 1 - the InfoServer 100 "routes" disk requests from Ethernet-connected devices to the virtual disks named as services which are then mapped to partitions to SCSI-attached disks. A "router" is anything that connects the two "transport medium(s)". See IS100 p.1-1)</p>
<p>“to map between the workstations and the storage devices;”</p>	<p>(Similar to claim 1. The storage space of the storage devices is addressed as "partitions" through the CREATE</p>

<p>“to implement access controls for storage space on the storage devices; and”</p> <p>“to allow access from the workstations to the storage devices using native low level, block protocol in accordance with the mapping and access controls.”</p>	<p>PARTITION command. See IS100 pp. 3-7 and 3-8. The partitions are mappings from a partition name to portions of the storage devices.</p> <p>The devices or partitions are then made available to connected devices as "SERVICES" via the CREATE SERVICE command which includes an optional "access control password". See IS100 p. 3-10. The password feature thus serves as an access control.</p> <p>At IS100 p. 1-1 it is said that each host can use its own "native file system" to access the InfoServer 100. In particular, the LAD protocol provides a mechanism for reading and writing logical disk blocks independent from any underlying file system. See also IS100 p. 2-2.) (At IS100 p. 1-1 it is said that each host can use its own "native file system" to access the InfoServer 100. In particular, the LAD protocol provides a mechanism for reading and writing logical disk blocks independent from any underlying file system. See also IS100 p. 2-2.)</p>
--	---

Hoese, claim 8

IS100

<p>“8. The storage network of claim 7, wherein the access controls include an allocation of subsets of storage space to associated workstations, wherein each subset is only accessible by the associated workstation.”</p>	<p>(Same as claim 2.)</p>
---	---------------------------

Hoese, claim 9

IS100

<p>“9. The storage network of claim 7, wherein the storage devices comprise hard disk drives.”</p>	<p>(Same as claim 4.)</p>
--	---------------------------

<p>“11. A method for providing virtual local storage on remote storage devices connected to one transport medium to devices connected to another transport medium, comprising:”</p>	<p>(Same as claim 1. IS100 at p.1-1 describes the Digital Equipment InfoServer 100 as a "virtual disk server" that serves sets of logical blocks to an Ethernet network-connected server. It is also said at pp. 2-1 to 2-2 of IS100 that the InfoServer 100 provides "access to the virtual disks it serves to the local-area network (LAN) via the Local Area Disk (LAD) and Local Area Storage Transport (LAST) protocols".</p>
<p>“interfacing with a first transport medium;”</p>	<p>IS100 at p.1-3 shows the InfoServer 100 connected to an Ethernet LAN segment, thus the InfoServer 100 inherently had an Ethernet Network Interface Controller (NIC).</p>
<p>“interfacing with a second transport medium;”</p>	<p>IS100 at pp. 2-7 and 2-8 refer to two SCSI buses, one internal and one external. Pp. 3-44 through 3-46 of IS100 describe a SHOW DEVICE command which displays the status of storage devices attached to the IS100 via the SCSI buses.)</p>
<p>“mapping between devices connected to the first transport medium and the storage devices”</p>	<p>The storage space of the storage devices is addressed as "partitions" through the CREATE PARTITION command. See IS100 pp. 3-7 and 3-8. The partitions are mappings from a partition name to portions of the storage devices.</p>
<p>“and that implements access controls for storage space on the storage devices; and”</p>	<p>The devices or partitions are then made available to connected devices as "SERVICES" via the CREATE SERVICE command which includes an optional "access control password". See IS100 p. 3-10. The password feature thus serves as an access control.</p>

<p>“allowing access from devices connected to the first transport medium to the storage devices using native low level, block protocols.”</p>	<p>At IS100 p. 1-1 it is said that each host can use its own "native file system" to access the InfoServer 100. In particular, the LAD protocol provides a mechanism for reading and writing logical disk blocks independent from any underlying file system. See also IS100 p. 2-2.)</p>
---	---

Hoese, claim 12

IS100

<p>“12. The method of claim 11, wherein mapping between devices connected to the first transport medium and the storage devices includes allocating subsets of storage space to associated devices connected to the first transport medium, wherein each subset is only accessible by the associated device connected to the first transport medium.”</p>	<p>(Same as claim 2.)</p>
---	---------------------------

Hoese, claim 13

IS100

<p>“13. The method of claim 12, wherein the devices connected to the first transport medium comprise workstations.”</p>	<p>(Same as claim 3.)</p>
---	---------------------------

Hoese, claim 14

IS100

<p>“14. The method of claim 12, wherein the storage devices comprise hard disk drives”</p>	<p>(Same as claim 4.)</p>
--	---------------------------

B. Claim 5 of Hoese is unpatentable under 35 U.S.C. §103 as being obvious over the IS100 prior art document in view of the LANCE document.

Claim 5 depends from claim 1 and adds additional features. These additional features are found in an Ethernet integrated circuit known as the Advanced Micro Devices (AMD) Am7990,

as described in the LANCE document. A chart listing the correspondence of these claim features appears below.

It would have been obvious to one of skill in the art at the time of filing the Hoese patent to combine the teachings of the IS100 document and the LANCE document, for several reasons. First, textbooks such as Johnson suggested, circa 1993, that "DMA is a common feature of modern Ethernet controllers" (see Johnson, p. 3). Second, there is evidence that such a combination had actually been made in the prior art. The IS150 Manual describes the InfoServer 150, a second generation version of the IS100 which was introduced by Digital Equipment Corporation no later than the end of 1991. The IS150 Photos show an internal photograph of the InfoServer 150, and an Am7990 chip was clearly part of that product.

Claim 5 of Hoese reads on the prior art as quoted below:

"5. The storage router of claim 1, wherein the first controller comprises:"	(The Am7990 chip provided Ethernet access and used FIFOs and DMA as integral components. See LANCE pp. 193-200)
"a first protocol unit operable to connect to the first transport medium;"	(The Am7990 controller's "primary task is to carry out the basic Ethernet protocol functions". LANCE, p. 193, bottom left column)
"a first-in-first-out queue coupled to the first protocol unit; and"	("The ring behaves like a wraparound FIFO storage register". LANCE, pp. 195.)
"a direct memory access (DMA) interface coupled to the first-in-first-out queue and to the buffer."	(The Am7990 also provided an internal DMA interface to the FIFO ring buffers as well as a BCON bit used to program different DMA modes of the Am7990. LANCE at pp. 195-197. Also see p. 200, top right hand column, where an overflow error is reported if an internal FIFO of LANCE fills and cannot be emptied because of an abnormal latency in servicing a DMA request.)

C. Claim 6 is unpatentable under 35 U.S.C. §103 as being obvious over the prior art document IS100 in view of the DP5380 prior art document. A claim chart listing the correspondence between claim 6 and these documents appear below. It would have been obvious to combine the teachings of the IS100 and DP5380 documents. Indeed, there is evidence that such a combination had actually been made long before the filing date of the Hoese patent. As is evidenced by the IS150 Manual and the IS150 Photos, an "NCR5380" chip was part of the Digital Equipment Corporation InfoServer 150 no later than the end of 1991. The NCR5380 chip is pin and program compatible with the DP5380 chip, as described on the first page of the DP5380 document.

Claim 6 of Hoese reads on the prior art as quoted below:

"6. The storage router of claim 1, wherein the second controller comprises:"	(The DP5380 chip is a SCSI controller. See DP5380, p. 1.)
"a second protocol unit operable to connect to the second transport medium;"	(The DP5380 has a SCSI controller that receives and transmits data to and from a SCSI bus. See DP5380 generally.)
"an internal buffer coupled to the second protocol unit; and"	(The DP5380 has internal data input and data output registers. DP5380, p. 3, Figure 2, "ASI block diagram".)
"a direct memory access (DMA) interface coupled to the internal buffer and to the buffer of the storage router."	(The DP5380 also had a DMA mode of operation. See DP5380, p.1 and the description of the DMA send, DMA target, and DMA initiator registers at p.9; see also the description of the non-block mode DMA, block mode DMA, and pseudo-DMA modes at pp. 11-12.)

D. Claim 10 of Hoese is considered to be unpatentable under 35 U.S.C. §103 as being obvious in view of prior art documents IS100, LANCE and DP5380. A claim chart listing the correspondence between claim 10 and these documents appears below.

It would have been obvious to combine the teachings of the IS100, LANCE and DP5380 documents. Indeed, there is evidence that such a combination had actually been made long before the filing date of the Hoese patent. As is evidenced by the IS150 Manual and the IS150 Photos, an "Am7990" and an "NCR5380" chip were part of the Digital Equipment Corporation InfoServer 150 no later than the end of 1991. The Am7990 is described in the LANCE document. The NCR5380 chip is pin and program compatible with the DP5380 chip, as described on the first page of the DP5380 document.

Claim 10 of Hoese reads on the prior art as quoted below:

<p>"10. The storage network of claim 7, wherein the storage router comprises:"</p> <p>"a buffer providing memory work space for the storage router;"</p>	<p>(IS100 at p.3-64 refers to a "pool" of memory whose pool size is displayed on request and that the pool being memory is made available to the running software, for use in serving disks.)</p>
<p>"a first controller operable to connect to and interface with the first transport medium, the first controller further operable to pull outgoing data from the buffer and to place incoming data into the buffer;"</p>	<p>(The LANCE document describes the Am7990, which was an Ethernet controller that had a DMA interface. The reference in the claim to "pull outgoing data" is considered to be a reference to the functions of the DMA interface. See also the discussion of claim 5 above.)</p>
<p>"a second controller operable to connect to and interface with the second transport medium, the second controller further operable to pull outgoing data from the buffer and to place incoming data into the buffer; and"</p>	<p>(The DP5380 describes a SCSI controller that had a DMA interface. The reference to "pull outgoing data" is considered to be a reference to the DMA interface functions. See also the discussion of claim 6 above.)</p>

<p>“a supervisor unit coupled to the first controller, the second controller and the buffer, the supervisor unit operable:</p> <p>to map between devices connected to the first transport medium and the storage devices,</p> <p>to implement the access controls for storage space on the storage devices and</p> <p>to process data in the buffer to interface between the first controller and the second controller to allow access from workstations to storage devices.”</p>	<p>(Same as claim 1. The InfoServer 100 internal processor provided connectivity between the first and second controller to process data in the buffer, in other words, it receives data from the Ethernet interface and stores it on the disks connected to the SCSI interface.</p> <p>Mapping is provided by the PARTITION and SERVICES commands. See IS100, p. 2-6, section 2.5.2, pp. 3-7 through 3-12, p. 3-27 and pp. 3-40 through 3.43.). The storage space of the storage devices is addressed by the network devices as "partitions" through the CREATE PARTITION command. See IS100 pp. 3-7 and 3-8.</p> <p>The devices or partitions are then made available to connected devices as "SERVICES" via the CREATE SERVICE command which includes an optional "access control password". See IS100 p. 3-10. The password feature thus serves as an access control.</p> <p>At IS100 p. 1-1 it is said that each host can use its own "native file system" to access the InfoServer 100. In particular, the LAD protocol provides a mechanism for reading and writing logical disk blocks independent from any underlying file system. See also IS100 p. 2-2)</p>
--	--

IV. Conclusion

The prior art documents referred to above were not considered during prosecution of the Hoese patent, nor have they been cited in the Pending Request, Reexamination Control No. 90/007,125 filed July 19, 2004. Further, these prior art documents are more pertinent to the subject matter of Hoese than any prior art reference which were previously cited during

prosecution of the Hoeser patent. It is clear from the foregoing discussion that substantial new questions of patentability have been raised by this previously unconsidered prior art and that claims 1-14 in Hoeser are unpatentable over this prior art. Accordingly, it is respectfully requested that this request for reexamination of the Hoeser patent be granted.

Respectfully submitted,

William A. Blake

William A. Blake
Registration No. 30,548

Jones, Tullar & Cooper, P.C.
P.O. Box 2266 Eads Station
Arlington, VA 22202
703-415-1500
Date: November 23, 2004



US006425035132

(12) **United States Patent**
Hoese et al.

(10) **Patent No.:** US 6,425,035 B2
(45) **Date of Patent:** Jul. 23, 2002

(54) **STORAGE ROUTER AND METHOD FOR PROVIDING VIRTUAL LOCAL STORAGE**

(75) Inventors: **Geoffrey B. Hoese**, Austin; **Jeffrey T. Russell**, Cibolo, both of TX (US)

(73) Assignee: **Crossroads Systems, Inc.**, Austin, TX (US)

(*) Notice: Subject to any disclaimer, the term of this patent is extended or adjusted under 35 U.S.C. 154(b) by 0 days.

This patent is subject to a terminal disclaimer.

5,935,260 A	*	8/1999	Ofer	714/42
5,941,972 A	*	8/1999	Hoese et al.	710/129
5,959,994 A	*	9/1999	Boggs et al.	370/399
6,041,381 A	*	3/2000	Hoese	710/129
6,055,603 A	*	4/2000	Ofer et al.	711/113
6,065,087 A	*	5/2000	Keaveny et al.	710/129
6,075,863 A	*	6/2000	Krishnan et al.	380/49
6,098,149 A	*	8/2000	Ofer et al.	711/112
6,118,766 A	*	9/2000	Akers	370/249
6,148,004 A	*	11/2000	Nelson et al.	370/463
6,185,203 B1	*	2/2001	Berman	370/351
6,209,023 B1	*	3/2001	Dimitroff et al.	709/211
6,230,218 B1	*	5/2001	Caspers et al.	710/219
6,341,315 B1	*	1/2002	Arroyo et al.	709/220
6,343,324 B1	*	1/2002	Hubis et al.	709/229

* cited by examiner

(21) Appl. No.: **09/965,335**

(22) Filed: **Sep. 27, 2001**

Related U.S. Application Data

(63) Continuation of application No. 09/354,682, filed on Jul. 15, 1999, which is a continuation of application No. 09/001,799, filed on Dec. 31, 1997, now Pat. No. 5,941,972.

(51) **Int. Cl.** **G06F 13/00**

(52) **U.S. Cl.** **710/129; 710/128; 710/8; 710/36; 710/105**

(58) **Field of Search** **710/1-5, 8-13, 710/36-38, 105, 100-101, 126-131; 711/100, 112, 113; 714/42**

References Cited

U.S. PATENT DOCUMENTS

5,748,924 A	*	5/1998	Llorens et al.	710/129
5,768,623 A	*	6/1998	Judd et al.	710/37
5,809,328 A	*	9/1998	Nogales et al.	710/5
5,812,754 A	*	9/1998	Lui et al.	714/6
5,835,496 A	*	11/1998	Yeung et al.	370/514
5,848,251 A	*	12/1998	Lomelino et al.	710/129

Primary Examiner—Christopher B. Shin

(74) Attorney, Agent, or Firm—Gray Cary Ware & Friedrich LLP

(57) **ABSTRACT**

A storage router (56) and storage network (50) provide virtual local storage on remote SCSI storage devices (60, 62, 64) to Fiber Channel devices. A plurality of Fiber Channel devices, such as workstations (58), are connected to a Fiber Channel transport medium (52), and a plurality of SCSI storage devices (60, 62, 64) are connected to a SCSI bus transport medium (54). The storage router (56) interfaces between the Fiber Channel transport medium (52) and the SCSI bus transport medium (54). The storage router (56) maps between the workstations (58) and the SCSI storage devices (60, 62, 64) and implements access controls for storage space on the SCSI storage devices (60, 62, 64). The storage router (56) then allows access from the workstations (58) to the SCSI storage devices (60, 62, 64) using native low level, block protocol in accordance with the mapping and the access controls.

14 Claims, 2 Drawing Sheets

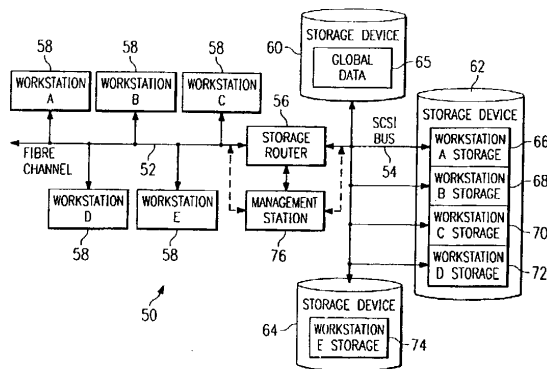

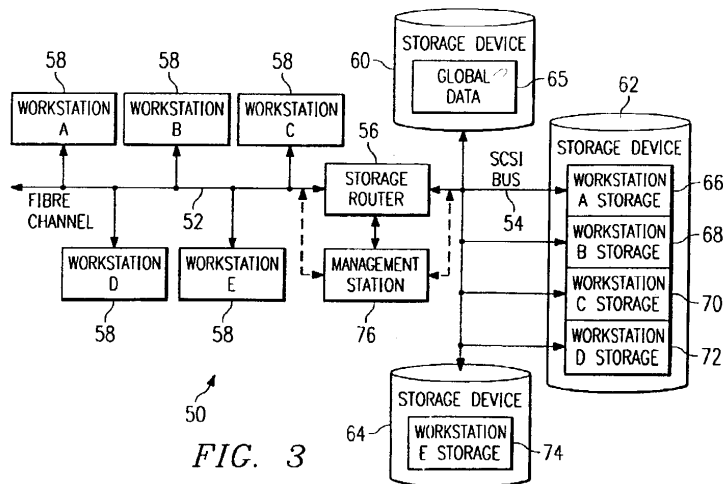
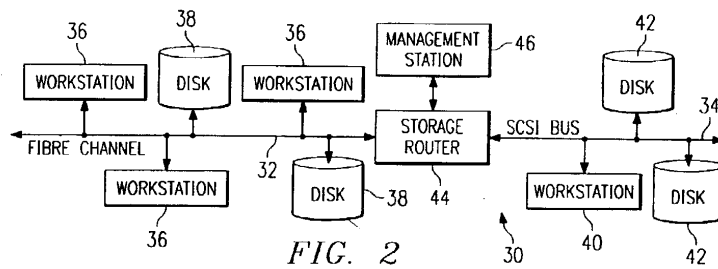
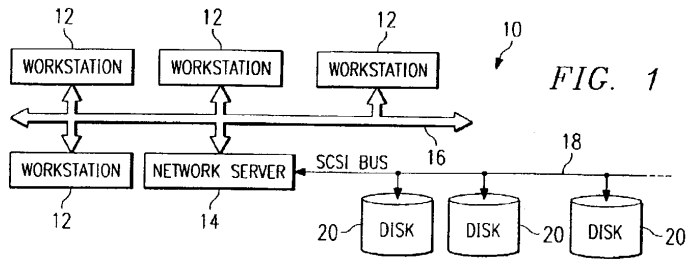

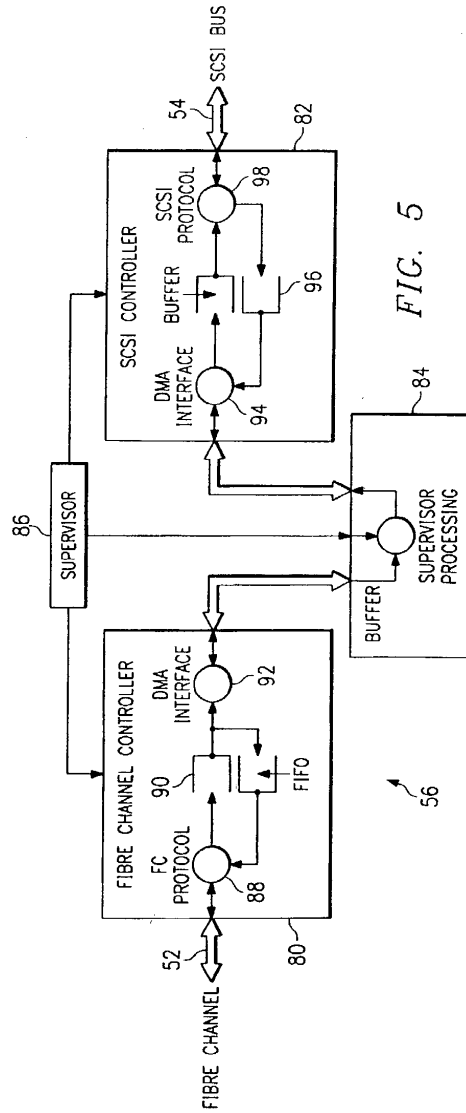
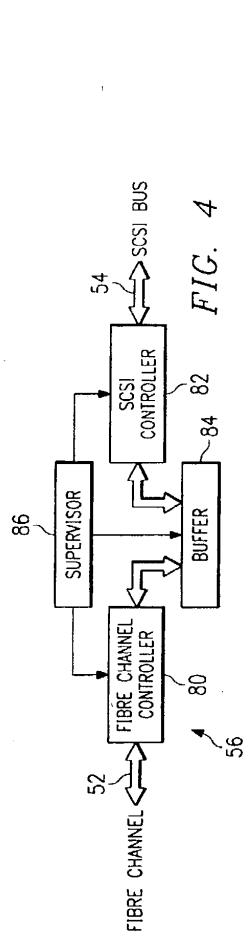

1
STORAGE ROUTER AND METHOD FOR PROVIDING VIRTUAL LOCAL STORAGE RELATED APPLICATIONS

This application claims the benefit of the filing date of U.S. patent application Ser. No. 09/354,682 by inventors Geoffrey B. Hoese and Jeffrey T. Russell, entitled "Storage Router and Method for Providing Virtual Local Storage" filed on Jul. 15, 1999, which is a continuation of U.S. patent application Ser. No. 091001,799, filed on Dec. 31, 1997, now U.S. Pat. No. 5,941,972, and hereby incorporates these applications by reference in their entireties as if they had been fully set forth herein.

TECHNICAL FIELD OF THE INVENTION

This invention relates in general to network storage devices, and more particularly to a storage router and method for providing virtual local storage on remote SCSI storage devices to Fiber Channel devices.

BACKGROUND OF THE INVENTION

Typical storage transport mediums provide for a relatively small number of devices to be attached over relatively short distances. One such transport medium is a Small Computer System Interface (SCSI) protocol, the structure and operation of which is generally well known as is described, for example, in the SCSI-1, SCSI 2 and SCSI-3 specifications. High speed serial interconnects provide enhanced capability to attach a large number of high speed devices to a common storage transport medium over large distances. One such serial interconnect is Fibre Channel, the structure and operation of which is described, for example, in Fibre Channel Physical and Signaling Interface (FC-PH), ANSI X3.230 Fiber Channel Arbitrated Loop (FC-AL), and ANSI X3.272 Fiber Channel Private Loop Direct Attach (FC-PLDA).

Conventional computing devices, such as computer workstations, generally access storage locally or through network interconnects. Local storage typically consists of a disk drive, tape drive, CD-ROM drive or other storage device contained within, or locally connected to the workstation. The workstation provides a file system structure, that includes security controls, with access to the local storage device through native low level, block protocols. These protocols map directly to the mechanisms used by the storage device and consist of data requests without security controls. Network interconnects typically provide access for a large number of computing devices to data storage on a remote network server. The remote network server provides file system structure, access control, and other miscellaneous capabilities that include the network interface. Access to data through the network server is through network protocols that the server must translate into low level requests to the storage device. A workstation with access to the server storage must translate its file system protocols into network protocols that are used to communicate with the server. Consequently, from the perspective of a workstation, or other computing device, seeking to access such server data, the access is much slower than access to data on a local storage device.

SUMMARY OF THE INVENTION

In accordance with the present invention, a storage router and method for providing virtual local storage on remote SCSI storage devices to Fiber Channel devices are disclosed that provide advantages over conventional network storage devices and methods.

2

According to one aspect of the present invention, a storage router and storage network provide virtual local storage on remote SCSI storage devices to Fiber Channel devices. A plurality of Fiber Channel devices, such as workstations, are connected to a Fiber Channel transport medium, and a plurality of SCSI storage devices are connected to a SCSI bus transport medium. The storage router interfaces between the Fiber Channel transport medium and the SCSI bus transport medium. The storage router maps between the workstations and the SCSI storage devices and implements access controls for storage space on the SCSI storage devices. The storage router then allows access from the workstations to the SCSI storage devices using native low level, block protocol in accordance with the mapping and the access controls.

According to another aspect of the present invention, virtual local storage on remote SCSI storage devices is provided to Fiber Channel devices. A Fibre Channel transport medium and a SCSI bus transport medium are interfaced with. A configuration is maintained for SCSI storage devices connected to the SCSI bus transport medium. The configuration maps between Fiber Channel devices and the SCSI storage devices and implements access controls for storage space on the SCSI storage devices. Access is then allowed from Fiber Channel initiator devices to SCSI storage devices using native low level, block protocol in accordance with the configuration.

A technical advantage of the present invention is the ability to centralize local storage for networked workstations without any cost of speed or overhead. Each workstation access its virtual local storage as if it work locally connected. Further, the centralized storage devices can be located in a significantly remote position even in excess of ten kilometers as defined by Fibre Channel standards.

Another technical advantage of the present invention is the ability to centrally control and administer storage space for connected users without limiting the speed with which the users can access local data. In addition, global access to data, backups, virus scanning and redundancy can be more easily accomplished by centrally located storage devices.

A further technical advantage of the present invention is providing support for SCSI storage devices as local storage for Fiber Channel hosts. In addition, the present invention helps to provide extended capabilities for Fiber Channel and for management of storage subsystems.

BRIEF DESCRIPTION OF THE DRAWINGS

A more complete understanding of the present invention and the advantages thereof may be acquired by referring to the following description taken in conjunction with the accompanying drawings, in which like reference numbers indicate like features, and wherein:

FIG. 1 is a block diagram of a conventional network that provides storage through a network server;

FIG. 2 is a block diagram of one embodiment of a storage network with a storage router that provides global access and routing;

FIG. 3 is a block diagram of one embodiment of a storage network with a storage router that provides virtual local storage;

FIG. 4 is a block diagram of one embodiment of the storage router of FIG. 3; and

FIG. 5 is a block diagram of one embodiment of data flow within the storage router of FIG. 4.

DETAILED DESCRIPTION OF THE INVENTION

FIG. 1 is a block diagram of a conventional network, indicated generally at 10, that provides access to storage

3

through a network server. As shown, network 10 includes a plurality of workstations 12 interconnected with a network server 14 via a network transport medium 16. Each workstation 12 can generally comprise a processor, memory, input/output devices, storage devices and a network adapter as well as other common computer components. Network server 14 uses a SCSI bus 18 as a storage transport medium to interconnect with a plurality of storage devices 20 (tape drives, disk drives, etc.). In the embodiment of FIG. 1, network transport medium 16 is a network connection and storage devices 20 comprise hard disk drives, although there are numerous alternate transport mediums and storage devices.

In network 10, each workstation 12 has access to its local storage device as well as network access to data on storage devices 20. The access to a local storage device is typically through native low level, block protocols. On the other hand, access by a workstation 12 to storage devices 20 requires the participation of network server 14 which implements a file system and transfers data to workstations 12 only through high level file system protocols. Only network server 14 communicates with storage devices 20 via native low level, block protocols. Consequently, the network access by workstations 12 through network server 14 is slow with respect to their access to local storage. In network 10, it can also be a logistical problem to centrally manage and administer local data distributed across an organization, including accomplishing tasks such as backups, virus scanning and redundancy.

FIG. 2 is a block diagram of one embodiment of a storage network, indicated generally at 30, with a storage router that provides global access and routing. This environment is significantly different from that of FIG. 1 in that there is no network server involved. In FIG. 2, a Fiber Channel high speed serial transport 32 interconnects a plurality of workstations 36 and storage devices 38. A SCSI bus storage transport medium interconnects workstations 40 and storage devices 42. A storage router 44 then serves to interconnect these mediums and provide devices on either medium global, transparent access to devices on the other medium. Storage router 44 routes requests from initiator devices on one medium to target devices on the other medium and routes data between the target and the initiator. Storage router 44 can allow initiators and targets to be on either side. In this manner, storage router 44 enhances the functionality of Fiber Channel 32 by providing access, for example, to legacy SCSI storage devices on SCSI bus 34. In the embodiment of FIG. 2, the operation of storage router 44 can be managed by a management station 46 connected to the storage router via a direct serial connection.

In storage network 30, any workstation 36 or workstation 40 can access any storage device 38 or storage device 42 through native low level, block protocols, and vice versa. This functionality is enabled by storage router 44 which routes requests and data as a generic transport between Fiber Channel 32 and SCSI bus 34. Storage router 44 uses tables to map devices from one medium to the other and distributes requests and data across Fiber Channel 32 and SCSI bus 34 without any security access controls. Although this extension of the high speed serial interconnect provided by Fiber Channel 32 is beneficial, it is desirable to provide security controls in addition to extended access to storage devices through a native low level, block protocol.

FIG. 3 is a block diagram of one embodiment of a storage network, indicated generally at 50, with a storage router that provides virtual local storage. Similar to that of FIG. 2, storage network 50 includes a Fiber Channel high speed

4

serial interconnect 52 and a SCSI bus 54 bridged by a storage router 56. Storage router 56 of FIG. 3 provides for a large number of workstations 58 to be interconnected on a common storage transport and to access common storage devices 60, 62 and 64 through native low level, block protocols.

According to the present invention, storage router 56 has enhanced functionality to implement security controls and routing such that each workstation 58 can have access to a specific subset of the overall data stored in storage devices 60, 62 and 64. This specific subset of data has the appearance and characteristics of local storage and is referred to herein as virtual local storage. Storage router 56 allows the configuration and modification of the storage allocated to each attached workstation 58 through the use of mapping tables or other mapping techniques.

As shown in FIG. 3, for example, storage device 60 can be configured to provide global data 65 which can be accessed by all workstations 58. Storage device 62 can be configured to provide partitioned subsets 66, 68, 70 and 72, where each partition is allocated to one of the workstations 58 (workstations A, B, C and D). These subsets 66, 68, 70 and 72 can only be accessed by the associated workstation 58 and appear to the associated workstation 58 as local storage accessed using native low level, block protocols. Similarly, storage device 64 can be allocated as storage for the remaining workstation 58 (workstation E).

Storage router 56 combines access control with routing such that each workstation 58 has controlled access to only the specified partition of storage device 62 which forms virtual local storage for the workstation 58. This access control allows security control for the specified data partitions. Storage router 56 allows this allocation of storage devices 60, 62 and 64 to be managed by a management station 76. Management station 76 can connect directly to storage router 56 via a direct connection or, alternately, can interface with storage router 56 through either Fiber Channel 52 or SCSI bus 54. In the latter case, management station 76 can be a workstation or other computing device with special rights such that storage router 56 allows access to mapping tables and shows storage devices 60, 62 and 64 as they exist physically rather than as they have been allocated.

The environment of FIG. 3 extends the concept of a single workstation having locally connected storage devices to a storage network 50 in which workstations 58 are provided virtual local storage in a manner transparent to workstations 58. Storage router 56 provides centralized control of what each workstation 58 sees as its local drive, as well as what data it sees as global data accessible by other workstations 58. Consequently, the storage space considered by the workstation 58 to be its local storage is actually a partition (i.e., logical storage definition) of a physically remote storage device 60, 62 or 64 connected through storage router 56. This means that similar requests from workstations 58 for access to their local storage devices produce different accesses to the storage space on storage devices 60, 62 and 64. Further, no access from a workstation 58 is allowed to the virtual local storage of another workstation 58.

The collective storage provided by storage devices 60, 62 and 64 can have blocks allocated by programming means within storage router 56. To accomplish this function, storage router 56 can include routing tables and security controls that define storage allocation for each workstation 58. The advantages provided by implementing virtual local storage in centralized storage devices include the ability to do collective backups and other collective administrative func-

5

tions more easily. This is accomplished without limiting the performance of workstations 58 because storage access involves native low level, block protocols and does not involve the overhead of high level protocols and file systems required by network servers.

FIG. 4 is a block diagram of one embodiment of storage router 56 of FIG. 3. Storage router 56 can comprise a Fiber Channel controller 80 that interfaces with Fiber Channel 52 and a SCSI controller 82 that interfaces with SCSI bus 54. A buffer 84 provides memory work space and is connected to both Fiber Channel controller 80 and to SCSI controller 82. A supervisor unit 86 is connected to Fiber Channel controller 80, SCSI controller 82 and buffer 84. Supervisor unit 86 comprises a microprocessor for controlling operation of storage router 56 and to handle mapping and security access for requests between Fiber Channel 52 and SCSI bus 54.

FIG. 5 is a block diagram of one embodiment of data flow within storage router 56 of FIG. 4. As shown, data from Fiber Channel 52 is processed by a Fibre Channel (FC) protocol unit 88 and placed in a FIFO queue 90. A direct memory access (DMA) interface 92 then takes data out of FIFO queue 90 and places it in buffer 84.

Supervisor unit 86 processes the data in buffer 84 as represented by supervisor processing 93. This processing involves mapping between Fiber Channel 52 and SCSI bus 54 and applying access controls and routing functions. A DMA interface 94 then pulls data from buffer 84 and places it into a buffer 96. A SCSI protocol unit 98 pulls data from buffer 96 and communicates the data on SCSI bus 54. Data flow in the reverse direction, from SCSI bus 54 to Fiber Channel 52, is accomplished in a reverse manner.

The storage router of the present invention is a bridge device that connects a Fiber Channel link directly to a SCSI bus and enables the exchange of SCSI command set information between application clients on SCSI bus devices and the Fiber Channel links. Further, the storage router applies access controls such that virtual local storage can be established in remote SCSI storage devices for workstations on the Fiber Channel link. In one embodiment, the storage router provides a connection for Fiber Channel links running the SCSI Fiber Channel Protocol (FCP) to legacy SCSI devices attached to a SCSI bus. The Fiber Channel topology is typically an Arbitrated Loop (FC_{AL}).

In part, the storage router enables a migration path to Fiber Channel based, serial SCSI networks by providing connectivity for legacy SCSI bus devices. The storage router can be attached to a Fiber Channel Arbitrated Loop and a SCSI bus to support a number of SCSI devices. Using configuration settings, the storage router can make the SCSI bus devices available on the Fiber Channel network as FCP logical units. Once the configuration is defined, operation of the storage router is transparent to application clients. In this manner, the storage router can form an integral part of the migration to new Fibre Channel based networks while providing a means to continue using legacy SCSI devices.

In one implementation (not shown), the storage router can be a rack mount or free standing device with an internal power supply. The storage router can have a Fibre Channel and SCSI port, and a standard, detachable power cord can be used, the FC connector can be a copper DB9 connector, and the SCSI connector can be a 68-pin type. Additional modular jacks can be provided for a serial port and a 802.3 10BaseT port, i.e. twisted pair Ethernet, for management access. The SCSI port of the storage router can support SCSI direct and sequential access target devices and can support SCSI

6

initiators, as well. The Fiber Channel port can interface to SCSI-3 FCP enabled devices and initiators.

To accomplish its functionality, one implementation of the storage router uses: a Fiber Channel interface based on the HEWLETT-PACKARD TACHYON HPFC-5000 controller and a GLM media interface; an Intel 80960RP processor, incorporating independent data and program memory spaces, and associated logic required to implement a stand alone processing system; and a serial port for debug and system configuration. Further, this implementation includes a SCSI interface supporting Fast-20 based on the SYMBIOS 53C8xx series SCSI controllers, and an operating system based upon the WIND RIVERS SYSTEMS VXWORKS or IXWORKS kernel, as determined, by design. In addition, the storage router includes software as required to control basic functions of the various elements, and to provide appropriate translations between the FC and SCSI protocols.

The storage router has various modes of operation that are possible between FC and SCSI target and initiator combinations. These modes are: FC Initiator to SCSI Target; SCSI Initiator to FC Target; SCSI Initiator to SCSI Target; and FC Initiator to FC Target. The first two modes can be supported concurrently in a single storage router device are discussed briefly below. The third mode can involve two storage router devices back to back and can serve primarily as a device to extend the physical distance beyond that possible via a direct SCSI connection. The last mode can be used to carry FC protocols encapsulated on other transmission technologies (e.g. ATM, SONET), or to act as a bridge between two FC loops (e.g. as a two port fabric).

The FC Initiator to SCSI Target mode provides for the basic configuration of a server using Fiber Channel to communicate with SCSI targets. This mode requires that a host system have an FC attached device and associated device drivers and software to generate SCSI-3 FCP requests. This system acts as an initiator using the storage router to communicate with SCSI target devices. The SCSI devices supported can include SCSI-2 compliant direct or sequential access (disk or tape) devices. The storage router serves to translate command and status information and transfer data between SCSI-3 FCP and SCSI-2, allowing the use of standard SCSI-2 devices in a Fibre Channel environment.

The SCSI Initiator to FC Target mode provides for the configuration of a server using SCSI-2 to communicate with Fiber Channel targets. This mode requires that a host system has a SCSI-2 interface and driver software to control SCSI-2 target devices. The storage router will connect to the SCSI-2 bus and respond as a target to multiple target IDs. Configuration information is required to identify the target IDs to which the bridge will respond on the SCSI-2 bus. The storage router then translates the SCSI-2 requests to SCSI-3 FCP requests, allowing the use of FC devices with a SCSI host system. This will also allow features such as a tape device acting as an initiator on the SCSI bus to provide full support for this type of SCSI device.

In general, user configuration of the storage router will be needed to support various functional modes of operation. Configuration can be modified, for example, through a serial port or through an Ethernet port via SNMP (simple network management protocol) or a Telnet session. Specifically, SNMP manageability can be provided via an 802.3 Ethernet interface. This can provide for configuration changes as well as providing statistics and error information. Configuration can also be performed via TELNET or RS-232 interfaces

with menu driven command interfaces. Configuration information can be stored in a segment of flash memory and can be retained across resets and power off cycles. Password protection can also be provided.

In the first two modes of operation, addressing information is needed to map from FC addressing to SCSI addressing and vice versa. This can be 'hard' configuration data, due to the need for address information to be maintained across initialization and partial reconfigurations of the Fiber Channel address space. In an arbitrated loop configuration, user configured addresses will be needed for AL_PAs in order to insure that known addresses are provided between loop reconfigurations.

With respect to addressing, FCP and SCSI 2 systems employ different methods of addressing target devices. Additionally, the inclusion of a storage router means that a method of translating device IDs needs to be implemented. In addition, the storage router can respond to commands without passing the commands through to the opposite interface. This can be implemented to allow all generic FCP and SCSI commands to pass through the storage router to address attached devices, but allow for configuration and diagnostics to be performed directly on the storage router through the FC and SCSI interfaces.

Management commands are those intended to be processed by the storage router controller directly. This may include diagnostic, mode, and log commands as well as other vendor-specific commands. These commands can be received and processed by both the FCP and SCSI interfaces, but are not typically bridged to the opposite interface. These commands may also have side effects on the operation of the storage router, and cause other storage router operations to change or terminate.

A primary method of addressing management commands through the FCP and SCSI interfaces can be through peripheral device type addressing. For example, the storage router can respond to all operations addressed to logical unit (LUN) zero as a controller device. Commands that the storage router will support can include INQUIRY as well as vendor-specific management commands. These are to be generally consistent with SCC standard commands.

The SCSI bus is capable of establishing bus connections between targets. These targets may internally address logical units. Thus, the prioritized addressing scheme used by SCSI subsystems can be represented as follows: BUS:TARGET:LOGICAL UNIT. The BUS identification is intrinsic in the configuration, as a SCSI initiator is attached to only one-bus. Target addressing is handled by bus arbitration from information provided to the arbitrating device. Target addresses are assigned to SCSI devices directly, though some means of configuration, such as a hardware jumper, switch setting, or device specific software configuration. As such, the SCSI protocol provides only logical unit addressing within the Identify message. Bus and target information is implied by the established connection.

Fiber Channel devices within a fabric are addressed by a unique port identifier. This identifier is assigned to a port during certain well-defined states of the FC protocol. Individual ports are allowed to arbitrate for a known, user defined address. If such an address is not provided, or if arbitration for a particular user address fails, the port is assigned a unique address by the FC protocol. This address is generally not guaranteed to be unique between instances. Various scenarios exist where the AL_PA of a device will change, either after power cycle or loop reconfiguration.

The FC protocol also provides a logical unit address field within command structures to provide addressing to devices

internal to a port. The FCP_CMD payload specifies an eight byte LUN field. Subsequent identification of the exchange between devices is provided by the FQXID (Fully Qualified Exchange ID).

FC ports can be required to have specific addresses assigned. Although basic functionality is not dependent on this, changes in the loop configuration could result in disk targets changing identifiers with the potential risk of data corruption or loss. This configuration can be straightforward, and can consist of providing the device a loop-unique ID (AL_PA) in the range of "01h" to "EFh." Storage routers could be shipped with a default value with the assumption that most configurations will be using single storage routers and no other devices requesting the present ID. This would provide a minimum amount of initial configuration to the system administrator. Alternately, storage routers could be defaulted to assume any address so that configurations requiring multiple storage routers on a loop would not require that the administrator assign a unique ID to the additional storage routers.

Address translation is needed where commands are issued in the cases FC Initiator to SCSI Target and SCSI Initiator to FC Target. Target responses are qualified by the FQXID and will retain the translation acquired at the beginning of the exchange. This prevents configuration changes occurring during the course of execution of a command from causing data or state information to be inadvertently misdirected. Configuration can be required in cases of SCSI Initiator to FC Target, as discovery may not effectively allow for FCP targets to consistently be found. This is due to an FC arbitrated loop supporting addressing of a larger number of devices than a SCSI bus and the possibility of FC devices changing their AL_PA due to device insertion or other loop initialization.

In the direct method, the translation to BUS:TARGET:LUN of the SCSI address information will be direct. That is, the values represented in the FCP LUN field will directly map to the values in effect on the SCSI bus. This provides a clean translation and does not require SCSI bus discovery. It also allows devices to be dynamically added to the SCSI bus without modifying the address map. It may not allow for complete discovery by FCP initiator devices, as gaps between device addresses may halt the discovery process. Legacy SCSI device drivers typically halt discovery on a target device at the first unoccupied LUN, and proceed to the next target. This would lead to some devices not being discovered. However, this allows for hot plugged devices and other changes to the loop addressing.

In the ordered method, ordered translation requires that the storage router perform discovery on reset, and collapses the addresses on the SCSI bus to sequential FCP LUN values. Thus, the FCP LUN values 0-N can represent N+1 SCSI devices, regardless of SCSI address values, in the order in which they are isolated during the SCSI discovery process. This would allow the FCP initiator discovery process to identify all mapped SCSI devices without further configuration. This has the limitation that hot-plugged devices will not be identified until the next reset cycle. In this case, the address may also be altered as well.

In addition to addressing, according to the present invention, the storage router provides configuration and access controls that cause certain requests from FC Initiators to be directed to assigned virtual local storage partitioned on SCSI storage devices. For example, the same request for LUN 0 (local storage) by two different FC Initiators can be directed to two separate subsets of storage. The storage

9

router can use tables to map, for each initiator, what storage access is available and what partition is being addressed by a particular request. In this manner, the storage space provided by SCSI storage devices can be allocated to FC initiators to provide virtual local storage as well as to create any other desired configuration for secured access.

Although the present invention has been described in detail, it should be understood that various changes, substitutions, and alterations can be made hereto without departing from the spirit and scope of the invention as defined by the appended claims.

What is claimed is:

1. A storage router for providing virtual local storage on remote storage devices to devices, comprising:

- a buffer providing memory work space for the storage router;
- a first controller operable to connect to and interface with a first transport medium;
- a second controller operable to connect to and interface with a second transport medium; and
- a supervisor unit coupled to the first controller, the second controller and the buffer, the supervisor unit operable to map between devices connected to the first transport medium and the storage devices, to implement access controls for storage space on the storage devices and to process data in the buffer to interface between the first controller and the second controller to allow access from devices connected to the first transport medium to the storage devices using native low level, block protocols.

2. The storage router of claim 1, wherein the supervisor unit maintains an allocation of subsets of storage space to associated devices connected to the first transport medium, wherein each subset is only accessible by the associated device connected to the first transport medium.

3. The storage router of claim 2, wherein the devices connected to the first transport medium comprise workstations.

4. The storage router of claim 2, wherein the storage devices comprise hard disk drives.

5. The storage router of claim 1, wherein the first controller comprises:

- a first protocol unit operable to connect to the first transport medium;
- a first-in-first-out queue coupled to the first protocol unit; and
- a direct memory access (DMA) interface coupled to the first-in-first-out queue and to the buffer.

6. The storage router of claim 1, wherein the second controller comprises:

- a second protocol unit operable to connect to the second transport medium;
- an internal buffer coupled to the second protocol unit; and
- a direct memory access (DMA) interface coupled to the internal buffer and to the buffer of the storage router.

7. A storage network, comprising:

- a first transport medium;
- a second transport medium;
- a plurality of workstations connected to the first transport medium;
- a plurality of storage devices connected to the second transport medium; and

10

a storage router interfacing between the first transport medium and the second transport medium, the storage router providing virtual local storage on the storage devices to the workstations and operable:

- to map between the workstations and the storage devices;
- to implement access controls for storage space on the storage devices; and
- to allow access from the workstations to the storage devices using native low level, block protocol in accordance with the mapping and access controls.

8. The storage network of claim 7, wherein the access controls include an allocation of subsets of storage space to associated workstations, wherein each subset is only accessible by the associated workstation.

9. The storage network of claim 7, wherein the storage devices comprise hard disk drives.

10. The storage network of claim 7, wherein the storage router comprises:

- a buffer providing memory work space for the storage router;
- a first controller operable to connect to and interface with the first transport medium, the first controller further operable to pull outgoing data from the buffer and to place incoming data into the buffer;

a second controller operable to connect to and interface with the second transport medium, the second controller further operable to pull outgoing data from the buffer and to place incoming data into the buffer; and

a supervisor unit coupled to the first controller, the second controller and the buffer, the supervisor unit operable: to map between devices connected to the first transport medium and the storage devices, to implement the access controls for storage space on the storage devices and to process data in the buffer to interface between the first controller and the second controller to allow access from workstations to storage devices.

11. A method for providing virtual local storage on remote storage devices connected to one transport medium to devices connected to another transport medium, comprising:

- interfacing with a first transport medium;
- interfacing with a second transport medium;
- mapping between devices connected to the first transport medium and the storage devices and that implements access controls for storage space on the storage devices; and
- allowing access from devices connected to the first transport medium to the storage devices using native low level, block protocols.

12. The method of claim 11, wherein mapping between devices connected to the first transport medium and the storage devices includes allocating subsets of storage space to associated devices connected to the first transport medium, wherein each subset is only accessible by the associated device connected to the first transport medium.

13. The method of claim 12, wherein the devices connected to the first transport medium comprise workstations.

14. The method of claim 12, wherein the storage devices comprise hard disk drives.

* * * * *

9

router can use tables to map, for each initiator, what storage access is available and what partition is being addressed by a particular request. In this manner, the storage space provided by SCSI storage devices can be allocated to FC initiators to provide virtual local storage as well as to create any other desired configuration for secured access.

Although the present invention has been described in detail, it should be understood that various changes, substitutions, and alterations can be made hereto without departing from the spirit and scope of the invention as defined by the appended claims.

What is claimed is:

- 1. A storage router for providing virtual local storage on remote storage devices to devices, comprising:
 - a buffer providing memory work space for the storage router;
 - a first controller operable to connect to and interface with a first transport medium;
 - a second controller operable to connect to and interface with a second transport medium; and
 - a supervisor unit coupled to the first controller, the second controller and the buffer, the supervisor unit operable to map between devices connected to the first transport medium and the storage devices, to implement access controls for storage space on the storage devices and to process data in the buffer to interface between the first controller and the second controller to allow access from devices connected to the first transport medium to the storage devices using native low level, block protocols.
- 2. The storage router of claim 1, wherein the supervisor unit maintains an allocation of subsets of storage space to associated devices connected to the first transport medium, wherein each subset is only accessible by the associated device connected to the first transport medium.
- 3. The storage router of claim 2, wherein the devices connected to the first transport medium comprise workstations.
- 4. The storage router of claim 2, wherein the storage devices comprise hard disk drives.
- 5. The storage router of claim 1, wherein the first controller comprises:
 - a first protocol unit operable to connect to the first transport medium;
 - a first-in-first-out queue coupled to the first protocol unit; and
 - a direct memory access (DMA) interface coupled to the first-in-first-out queue and to the buffer.
- 6. The storage router of claim 1, wherein the second controller comprises:
 - a second protocol unit operable to connect to the second transport medium;
 - an internal buffer coupled to the second protocol unit; and
 - a direct memory access (DMA) interface coupled to the internal buffer and to the buffer of the storage router.
- 7. A storage network, comprising:
 - a first transport medium;
 - a second transport medium;
 - a plurality of workstations connected to the first transport medium;
 - a plurality of storage devices connected to the second transport medium; and

10

a storage router interfacing between the first transport medium and the second transport medium, the storage router providing virtual local storage on the storage devices to the workstations and operable:

- to map between the workstations and the storage devices;
 - to implement access controls for storage space on the storage devices; and
 - to allow access from the workstations to the storage devices using native low level, block protocol in accordance with the mapping and access controls.
- 8. The storage network of claim 7, wherein the access controls include an allocation of subsets of storage space to associated workstations, wherein each subset is only accessible by the associated workstation.
 - 9. The storage network of claim 7, wherein the storage devices comprise hard disk drives.
 - 10. The storage network of claim 7, wherein the storage router comprises:
 - a buffer providing memory work space for the storage router;
 - a first controller operable to connect to and interface with the first transport medium, the first controller further operable to pull outgoing data from the buffer and to place incoming data into the buffer;
 - a second controller operable to connect to and interface with the second transport medium, the second controller further operable to pull outgoing data from the buffer and to place incoming data into the buffer; and
 - a supervisor unit coupled to the first controller, the second controller and the buffer, the supervisor unit operable:
 - to map between devices connected to the first transport medium and the storage devices, to implement the access controls for storage space on the storage devices and to process data in the buffer to interface between the first controller and the second controller to allow access from workstations to storage devices.
 - 11. A method for providing virtual local storage on remote storage devices connected to one transport medium to devices connected to another transport medium, comprising:
 - interfacing with a first transport medium;
 - interfacing with a second transport medium;
 - mapping between devices connected to the first transport medium and the storage devices and that implements access controls for storage space on the storage devices; and
 - allowing access from devices connected to the first transport medium to the storage devices using native low level, block protocols.
 - 12. The method of claim 11, wherein mapping between devices connected to the first transport medium and the storage devices includes allocating subsets of storage space to associated devices connected to the first transport medium, wherein each subset is only accessible by the associated device connected to the first transport medium.
 - 13. The method of claim 12, wherein the devices connected to the first transport medium comprise workstations.
 - 14. The method of claim 12, wherein the storage devices comprise hard disk drives.

* * * * *

UNITED STATES PATENT AND TRADEMARK OFFICE
CERTIFICATE OF CORRECTION

PATENT NO. : 6,425,035 B2
DATED : July 23, 2002
INVENTOR(S) : Geoffrey B. Hoese et al.

Page 1 of 1

It is certified that error appears in the above-identified patent and that said Letters Patent is hereby corrected as shown below:

Column 10,

Line 47, delete "that implements" and insert -- implementing --

Signed and Sealed this

Twenty-sixth Day of August, 2003



JAMES E. ROGAN
Director of the United States Patent and Trademark Office

Under the Paperwork Reduction Act of 1995, no persons are required to respond to a collection of information unless it contains a valid OMB control number.

Substitute for form 1449B/PTO		Complete if Known	
INFORMATION DISCLOSURE STATEMENT BY APPLICANT (Use as many sheets as necessary)		Application Number	Patent No. 6,425,035
		Filing Date	Issue Date 07/23/2002
		First Named Inventor	HOESE
		Art Unit	
		Examiner Name	
		Attorney Docket Number	HOESE1/WAB
Sheet	1	of	1

NON PATENT LITERATURE DOCUMENTS			
Examiner Initials*	Cite No. ¹	Include name of the author (in CAPITAL LETTERS), title of the article (when appropriate), title of the item (book, magazine, journal, serial, symposium, catalog, etc.), date, page(s), volume-issue number(s), publisher, city and/or country where published.	T ²
	1	"InfoServer 100 System Operations Guide", First Edition, Digital Equipment Corporation, 1990	
	2	S.P. Joshi, "Ethernet controller chip interfaces with variety of 16-bit processors," Electronic Design, Hayden Publishing Co., Inc., Rochelle Park, NJ, Oct. 14, 1982. pp193-200	
	3	"DP5380 Asynchronous SCSI Interface", National Semiconductor Corporation, Arlington, TX, May 1989, pp. 1-32	
	4	Johnson, D.B., et al., "The Peregrine High Performance RPC System", Software--Practice & Experience, 23(2):201-221, Feb. 1993	
	5	"InfoServer 150--Installation and Owner's Guide", EK-INFSV-OM-001, Digital Equipment Corporation, Maynard, Massachusetts 1991, Chapters 1 and 2	
	6	Pictures of internal components of the InfoServer 150, taken from http://www.binarydinosaurs.couk/Museum/Digital/infoserver/infoserver.php in Nov. 2004	

Examiner Signature		Date Considered	
--------------------	--	-----------------	--

*EXAMINER: Initial if reference considered, whether or not citation is in conformance with MPEP 609. Draw line through citation if not in conformance and not considered. Include copy of this form with next communication to applicant.
¹Applicant's unique citation designation number (optional). ²Applicant is to place a check mark here if English language Translation is attached.
 This collection of information is required by 37 CFR 1.97 and 1.98. The information is required to obtain or retain a benefit by the public which is to file (and by the USPTO to process) an application. Confidentiality is governed by 35 U.S.C. 122 and 37 CFR 1.14. This collection is estimated to take 2 hours to complete, including gathering, preparing, and submitting the completed application form to the USPTO. Time will vary depending upon the individual case. Any comments on the amount of time you require to complete this form and/or suggestions for reducing this burden should be sent to the Chief Information Officer, U.S. Patent and Trademark Office, U.S. Department of Commerce, P.O. Box 1450, Alexandria, VA 22313-1450. DO NOT SEND FEES OR COMPLETED FORMS TO THIS ADDRESS. SEND TO: Commissioner for Patents, P.O. Box 1450, Alexandria, VA 22313-1450.

If you need assistance in completing the form, call 1-800-PTO-9199 and select option 2.

Application Number



Application No.

90/007,317

Examiner

Applicant(s)

6425035

Art Unit

2111

Index of Claims



Application No.

90/007,317

Examiner

Applicant(s)

6425035

Art Unit

2111

√	Rejected
=	Allowed

-	(Through numeral) Cancelled
+	Restricted

N	Non-Elected
I	Interference

A	Appeal
O	Objected

Claim		Date				Claim		Date				Claim		Date			
Final	Original					Final	Original					Final	Original				
1						51						101					
2						52						102					
3						53						103					
4						54						104					
5						55						105					
6						56						106					
7						57						107					
8						58						108					
9						59						109					
10						60						110					
11						61						111					
12						62						112					
13						63						113					
14						64						114					
15						65						115					
16						66						116					
17						67						117					
18						68						118					
19						69						119					
20						70						120					
21						71						121					
22						72						122					
23						73						123					
24						74						124					
25						75						125					
26						76						126					
27						77						127					
28						78						128					
29						79						129					
30						80						130					
31						81						131					
32						82						132					
33						83						133					
34						84						134					
35						85						135					
36						86						136					
37						87						137					
38						88						138					
39						89						139					
40						90						140					
41						91						141					
42						92						142					
43						93						143					
44						94						144					
45						95						145					
46						96						146					
47						97						147					
48						98						148					
49						99						149					
50						100						150					

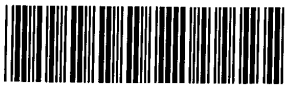
Issue Classification 	Application No.	Applicant(s)	
	90/007,317	6425035	
	Examiner	Art Unit	
		2111	

ISSUE CLASSIFICATION									
ORIGINAL				CROSS REFERENCE(S)					
CLASS	SUBCLASS			CLASS	SUBCLASS (ONE SUBCLASS PER BLOCK)				
710	105								
INTERNATIONAL CLASSIFICATION									
			/						
			/						
			/						
			/						
			/						

(Assistant Examiner) (Date)		Total Claims Allowed:	
(Legal Instruments Examiner) (Date)		(Primary Examiner) (Date)	O.G. Print Claim(s)

<input type="checkbox"/> Claims renumbered in the same order as presented by applicant										<input type="checkbox"/> CPA		<input type="checkbox"/> T.D.		<input type="checkbox"/> R.1.47	
Final	Original	Final	Original	Final	Original	Final	Original	Final	Original	Final	Original	Final	Original	Final	Original
	1		31		61		91		121		151		181		211
	2		32		62		92		122		152		182		212
	3		33		63		93		123		153		183		213
	4		34		64		94		124		154		184		214
	5		35		65		95		125		155		185		215
	6		36		66		96		126		156		186		216
	7		37		67		97		127		157		187		217
	8		38		68		98		128		158		188		218
	9		39		69		99		129		159		189		219
	10		40		70		100		130		160		190		220
	11		41		71		101		131		161		191		221
	12		42		72		102		132		162		192		222
	13		43		73		103		133		163		193		223
	14		44		74		104		134		164		194		224
	15		45		75		105		135		165		195		225
	16		46		76		106		136		166		196		226
	17		47		77		107		137		167		197		227
	18		48		78		108		138		168		198		228
	19		49		79		109		139		169		199		229
	20		50		80		110		140		170		200		230
	21		51		81		111		141		171		201		231
	22		52		82		112		142		172		202		232
	23		53		83		113		143		173		203		233
	24		54		84		114		144		174		204		234
	25		55		85		115		145		175		205		235
	26		56		86		116		146		176		206		236
	27		57		87		117		147		177		207		237
	28		58		88		118		148		178		208		238
	29		59		89		119		149		179		209		239
	30		60		90		120		150		180		210		240

Reexamination	Control No.	Applicant(s)
	90/007,317	
	Certificate Date	Certificate Number

Requester	Correspondence Address:	<input type="checkbox"/> Patent Owner	<input checked="" type="checkbox"/> Third Party
<p>William A. Blake JONES, TULLAR & COOPER, PC P.O. Box 2266 Eads Station Arlington, VA 22202</p>			

LITIGATION REVIEW <input type="checkbox"/>	(examiner initials)	(date)
	Case Name	Director Initials

PENDING OFFICE PROCEEDINGS	
TYPE OF PROCEEDING	NUMBER
1.	
2.	
3.	
4.	



UNITED STATES PATENT AND TRADEMARK OFFICE

UNITED STATES DEPARTMENT OF COMMERCE
 United States Patent and Trademark Office
 Address: COMMISSIONER FOR PATENTS
 P.O. Box 1459
 Alexandria, Virginia 22313-1450
 www.uspto.gov



Bib Data Sheet

CONFIRMATION NO. 1634

SERIAL NUMBER	FILING OR 371(c) DATE	CLASS	GROUP ART UNIT	ATTORNEY DOCKET NO.
90/007,317	11/23/2004	710	2111	HOESE1/WAB
APPLICANTS 6425035, Residence Not Provided; Crossroads Systems Inc.(Owner), Austin, TX; William A Blake(3rd. Pty. Req.), Arlington, VA; William A Blake, Arlington, VA				
** CONTINUING DATA ***** This application is a REX of 09/965,335 09/27/2001 PAT 6,425,035 which is a CON of 09/354,682 07/15/1999 PAT 6,421,753 which is a CON of 09/001,799 12/31/1997 PAT 5,941,972				
** FOREIGN APPLICATIONS *****				
Foreign Priority claimed <input type="checkbox"/> yes <input type="checkbox"/> no 35 USC 119 (a-d) conditions met <input type="checkbox"/> yes <input type="checkbox"/> no <input type="checkbox"/> Met after Allowance		STATE OR COUNTRY	SHEETS DRAWING	TOTAL CLAIMS
Verified and Acknowledged Examiner's Signature _____ Initials _____				14
				INDEPENDENT CLAIMS 3
ADDRESS 25094				
TITLE STORAGE ROUTER AND METHOD FOR PROVIDING VIRTUAL LOCAL STORAGE				
FILING FEE RECEIVED 2520	FEES: Authority has been given in Paper No. _____ to charge/credit DEPOSIT ACCOUNT No. _____ for following:		<input type="checkbox"/> All Fees <input type="checkbox"/> 1.16 Fees (Filing) <input type="checkbox"/> 1.17 Fees (Processing Ext. of time) <input type="checkbox"/> 1.18 Fees (Issue) <input type="checkbox"/> Other _____ <input type="checkbox"/> Credit	