

TO: Mail Stop 8
 Director of the U.S. Patent & Trademark Office
 P.O. Box 1450
 Alexandria, VA 22313-1450

**REPORT ON THE
 FILING OR DETERMINATION OF AN
 ACTION REGARDING A PATENT OR
 TRADEMARK**

In Compliance with 35 § 290 and/or 15 U.S.C. § 1116 you are hereby advised that a court action has been
 filed in the U.S. District Court Northern California on the following Patents or Trademarks:

DOCKET NO. CV 14-01727 MEJ	DATE FILED 4/15/2014	U.S. DISTRICT COURT 450 Golden Gate Avenue, San Francisco, CA 94102
PLAINTIFF NETAPP, INC.		DEFENDANT CROSSROADS SYSTEMS, INC
PATENT OR TRADEMARK NO.	DATE OF PATENT OR TRADEMARK	HOLDER OF PATENT OR TRADEMARK
1 7,051,147		
2 7,987,311		
3		Please See Attached.
4		
5		

In the above—entitled case, the following patent(s) have been included:

DATE INCLUDED	INCLUDED BY	<input type="checkbox"/> Amendment	<input type="checkbox"/> Answer	<input type="checkbox"/> Cross Bill	<input type="checkbox"/> Other Pleading
PATENT OR TRADEMARK NO.	DATE OF PATENT OR TRADEMARK	HOLDER OF PATENT OR TRADEMARK			
1					
2					
3					
4					
5					

In the above—entitled case, the following decision has been rendered or judgement issued:

DECISION/JUDGEMENT		
CLERK Richard W. Wicking	(BY) DEPUTY CLERK Hilary Jackson	DATE April 17, 2014

Copy 1—Upon initiation of action, mail this copy to Commissioner Copy 3—Upon termination of action, mail this copy to Commissioner
 Copy 2—Upon filing document adding patent(s), mail this copy to Commissioner Copy 4—Case file copy

1 DUANE MORRIS LLP
2 Karineh Khachatourian (CA SBN 202634)
3 kkhachatourian@duanemorris.com
4 Patrick S. Salceda (CA SBN 247978)
5 psalceda@duanemorris.com
6 David T. Xue, Ph.D. (CA SBN 256668)
7 dtxue@duanemorris.com
8 2475 Hanover Street
9 Palo Alto, CA 94304-1134
10 Telephone: 650.847.4150
11 Facsimile: 650.847.4151

12 Attorneys for Plaintiff
13 NETAPP, INC.

14 **UNITED STATES DISTRICT COURT**
15 **NORTHERN DISTRICT OF CALIFORNIA**
16 **SAN JOSE DIVISION**

17 NETAPP, INC.,

18 Plaintiff,

19 v.

20 CROSSROADS SYSTEMS, INC.

21 Defendant

Case No.

**COMPLAINT FOR DECLARATORY
JUDGMENT
DEMAND FOR JURY TRIAL**

22
23
24
25
26
27
28
COMPLAINT FOR DECLARATORY JUDGMENT AND DEMAND FOR JURY TRIAL

DM2\4870591.3 G1309\00003

1 Plaintiff NetApp, Inc. ("NetApp" or "Plaintiff"), by its attorneys, alleges as follows:

2 **NATURE OF THE ACTION**

3 This is an action by Plaintiff for Declaratory Judgment against Defendant Crossroads
4 Systems, Inc. ("Crossroads" or "Defendant"). NetApp seeks declaratory relief pursuant to 28 U.S.C.
5 §§ 2201 and 2202, declaring United States Patent Nos. 7,051,147 ("the '147 Patent") and 7,987,311
6 ("the '311 Patent") (collectively the "patents-in-suit") to be not infringed.

7 **THE PARTIES**

8 1. Plaintiff NetApp, Inc. is a Delaware corporation with its principal place of business at
9 495 East Java Drive, Sunnyvale, California 94089.

10 2. Defendant Crossroads is a corporation incorporated under the laws of the State of
11 Delaware and has its principal place of business at 11000 North MoPac Expressway, Austin, Texas,
12 78759.

13 **BACKGROUND STATEMENT**

14 3. NetApp brings this declaratory judgment action in response to accusations of
15 infringement involving the '147 and '311 Patents levied against NetApp by Crossroads for products
16 referenced in its "Concise Statement of Infringement" filed on April 9, 2014 in Civil Action No.
17 1:14-cv-149-SS currently pending in the Western District of Texas and attached hereto as Exhibit A.
18 Neither the '147 nor the '311 Patents were asserted in Crossroads' Original Complaint, nor has
19 Crossroads sought to amend its Original Complaint to include these patents.

20 4. Accordingly, NetApp brings this Declaratory Judgment action because an actual
21 allegation of infringement has been made by Crossroads related to the patents-in-suit.

22 **JURISDICTION AND VENUE**

23 5. This Court has subject matter jurisdiction over NetApp's request for a declaratory
24 judgment under 28 U.S.C. §§ 2201 and 2202. This action arises under the patent laws of the United
25 States, 35 U.S.C. §§ 100 et seq., which are within the subject matter jurisdiction of this Court under
26 28 U.S.C. §§ 1331 and 1338(a).

27 6. Crossroads' allegations threaten actual and imminent injury to NetApp that can be
28 redressed by judicial relief and that injury is of sufficient immediacy and reality to warrant the

1 issuance of a declaratory judgment. Absent a declaration of non-infringement, Crossroads'
2 continued wrongful assertions of infringement related to NetApp's products will cause NetApp
3 harm.

4 7. This Court has general and specific personal jurisdiction over Crossroads because of
5 its purposeful, systematic, and continuous contacts with California. Crossroads sells products and
6 services in California, including its StrongBox® product line and actively solicits customers in
7 California by presenting at conferences such as Createasphere's Digital Asset Management
8 Conference in Beverly Hills, California and the Hollywood Post Alliance Tech Retreat in Indian
9 Wells, California. Moreover, Crossroads maintains sales personnel in California and conducts
10 business in this district. This Court has personal jurisdiction over Crossroads for another reason:
11 Crossroads has purposefully directed into California its enforcement activities regarding the patents-
12 in-suit. On information and belief, Crossroads's licensing and enforcement efforts in California
13 have generated substantial revenues.

14 8. Venue is proper in this district pursuant to 28 U.S.C. § 1391(b) because, inter alia, a
15 substantial part of the events and omissions giving rise to the claims occurred here and because
16 Crossroads is subject to personal jurisdiction in this district.

17 INTRADISTRICT ASSIGNMENT

18 9. Division assignment to the San Jose Division of the United States District Court for
19 the Northern District of California is proper pursuant to Civil Local Rule 3-2(e) because this is both
20 an Intellectual Property Action that arose in, among other places, Santa Clara County, and because a
21 substantial part of the events giving rise to the claims occurred in Santa Clara County.

22 FACTUAL ALLEGATIONS

23 10. Crossroads purports to be the owner of the '147 Patent. The '147 Patent is entitled
24 "Storage router and method for providing virtual local storage" and issued on May 23, 2006. A copy
25 of the '147 Patent is attached hereto as Exhibit B.

26 11. Crossroads purports to be the owner of the '311 Patent. The '311 Patent is also
27 entitled "Storage router and method for providing virtual local storage" and issued on July 26, 2011.
28 A copy of the '311 Patent is attached hereto as Exhibit C.

FIRST CLAIM FOR RELIEF

(Declaratory Judgment of Non-Infringement of the '147 Patent)

12. NetApp incorporates by reference each of the allegations in the preceding paragraphs of this Complaint as if fully set forth herein.

13. No claim of the '147 Patent has been or is infringed, either directly or indirectly, by NetApp or the purchasers of NetApp's products.

14. As a result of the acts described in the foregoing paragraphs, there exists a substantial controversy of sufficient immediacy and reality between Crossroads and NetApp to warrant the issuance of a declaratory judgment that NetApp has not infringed, and does not infringe, directly or indirectly, any claim of the '147 Patent.

SECOND CLAIM FOR RELIEF

(Declaratory Judgment of Non-Infringement of the '311 Patent)

15. NetApp incorporates by reference each of the allegations in the preceding paragraphs of this Complaint as if fully set forth herein.

16. No claim of the '311 Patent has been or is infringed, either directly or indirectly, by NetApp or the purchasers of NetApp's products.

17. As a result of the acts described in the foregoing paragraphs, there exists a substantial controversy of sufficient immediacy and reality between Crossroads and NetApp to warrant the issuance of a declaratory judgment that NetApp has not infringed, and does not infringe, directly or indirectly, any claim of the '311 Patent.

PRAYER FOR RELIEF

WHEREFORE, Plaintiff prays for judgment as follows:

1. For entry of a declaration that NetApp products have not infringed and are not infringing, either directly or indirectly, any claim of the '147 or '311 Patents;

2. An order that Crossroads and each of its officers, employees, agents, attorneys, and any and all persons acting in concert or participation with them are restrained and enjoined from further prosecuting or instituting any action against NetApp claiming that the '147, and '311 Patents are infringed or from representing that NetApp's products or their use by the purchasers of those

1 products infringe the '147, and '311 Patents;

2 3. A declaration that this is an exceptional case under 35 U.S.C. § 285;

3 4. An award to NetApp of its costs and attorneys' fees incurred herein; and

4 5. For such other relief as the Court deems just and proper.

5 **JURY DEMAND**

6 NetApp demands a trial by jury on all issues so triable.

7 DUANE MORRIS LLP

8 Dated: April 15, 2014

By: /s/ Karineh Khachatourian

Karineh Khachatourian

Patrick S. Salceda

David T. Xue

9

10

Attorneys for Plaintiff
NETAPP, INC.

11

12

13

14

15

16

17

18

19

20

21

22

23

24

25

26

27

28

TO: Mail Stop 8 Director of the U.S. Patent and Trademark Office P.O. Box 1450 Alexandria, VA 22313-1450	REPORT ON THE FILING OR DETERMINATION OF AN ACTION REGARDING A PATENT OR TRADEMARK
---	--

In Compliance with 35 U.S.C. § 290 and/or 15 U.S.C. § 1116 you are hereby advised that a court action has been filed in the U.S. District Court Western District of Texas, Austin Division on the following
 Trademarks or Patents. (the patent action involves 35 U.S.C. § 292.);

DOCKET NO. 1:13-cv-1025-SS	DATE FILED 11/26/2013	U.S. DISTRICT COURT Western District of Texas, Austin Division
PLAINTIFF Crossroads Systems, Inc.		DEFENDANT Huawei Technologies Co. Ltd., Huawei Enterprise USA Inc. and Huawei Technologies USA Inc.
PATENT OR TRADEMARK NO.	DATE OF PATENT OR TRADEMARK	HOLDER OF PATENT OR TRADEMARK
1 see attached		
2 6,425,035		
3 7,934,041		
4 7,051,147		
5		

In the above—entitled case, the following patent(s)/ trademark(s) have been included:

DATE INCLUDED	INCLUDED BY <input type="checkbox"/> Amendment <input type="checkbox"/> Answer <input type="checkbox"/> Cross Bill <input type="checkbox"/> Other Pleading
PATENT OR TRADEMARK NO.	DATE OF PATENT OR TRADEMARK
1	
2	
3	
4	
5	

In the above—entitled case, the following decision has been rendered or judgement issued:

DECISION/JUDGEMENT

CLERK William G. Putnicki	(BY) DEPUTY CLERK <i>Deja Schwede</i>	DATE 11/27/2013
------------------------------	--	--------------------

Copy 1—Upon initiation of action, mail this copy to Director Copy 3—Upon termination of action, mail this copy to Director
 Copy 2—Upon filing document adding patent(s), mail this copy to Director Copy 4—Case file copy

- H. That Defendants account for and pay to Crossroads all damages caused by the infringement of the '041 Patent;
- I. That Crossroads receive enhanced damages from Defendants in the form of treble damages, pursuant to 35 U.S.C. § 284 based on Defendants' willful infringement of the '041 Patent;
- J. That Crossroads be granted pre-judgment and post-judgment interest on the damages caused to it by reason of Defendants' infringement of the '041 Patent, including pre-judgment and post-judgment interest on any enhanced damages or attorneys' fees award;
- K. That Defendants have infringed the '147 Patent;
- L. That such infringement of the '147 Patent by Defendants has been willful;
- M. That Defendants account for and pay to Crossroads all damages caused by the infringement of the '147 Patent;
- N. That Crossroads receive enhanced damages from Defendants in the form of treble damages, pursuant to 35 U.S.C. § 284 based on Defendants' willful infringement of the '147 Patent;
- O. That Crossroads be granted pre-judgment and post-judgment interest on the damages caused to it by reason of Defendants' infringement of the '147 Patent, including pre-judgment and post-judgment interest on any enhanced damages or attorneys' fees award;
- P. That Defendants pay Crossroads all of Crossroads' reasonable attorneys' fees and expenses;
- Q. That costs be awarded to Crossroads;

- R. That Defendants, Defendants' agents, employees, representatives, successors and assigns, and those acting in privity or in concert with Defendants, be preliminary and permanently enjoined from further infringement of the '035 Patent;
- S. That Defendant, Defendants' agents, employees, representatives, successors and assigns, and those acting in privity or in concert with Defendants, be preliminary and permanently enjoined from further infringement of the '041 Patent;
- T. That Defendants, Defendants' agents, employees, representatives, successors and assigns, and those acting in privity or in concert with Defendants, be preliminary and permanently enjoined from further infringement of the '147 Patent;
- U. That this is an exceptional case under 35 U.S.C. § 285; and
- V. That Crossroads be granted such other and further relief as the Court may deem just and proper under the circumstances.

DEMAND FOR JURY TRIAL

Crossroads hereby demands a trial by jury on all issues.

Dated: November 26, 2013

Respectfully submitted,

By: /s/ Steven Sprinkle
Steven Sprinkle
Texas Bar No. 00794962
Elizabeth J. Brown Fore
Texas Bar No. 24001795
Sprinkle IP Law Group, PC
1301 W. 25th Street, Suite 408
Austin, Texas 78705
Tel: 512-637-9220
Fax: 512-371-9088
ssprinkle@sprinklelaw.com
ebrownfore@sprinklelaw.com

Susan K. Knoll
Texas Bar No. 11616900
Russell T. Wong
Texas Bar No. 21884235
James H. Hall
Texas Bar No. 24041040
WONG, CABELLO, LUTSCH,
RUTHERFORD & BRUCCULERI, L.L.P.
20333 SH 249, Suite 600
Houston, TX 77070
Tel: 832-446-2400
Fax: 832-446-2424
sknoll@counselip.com
rwong@counselip.com
jhall@counselip.com

*ATTORNEYS FOR PLAINTIFF
CROSSROADS SYSTEMS, INC.*

JURISDICTION AND VENUE

5. This action arises under the laws of the United States, more specifically under 35 U.S.C. § 100, *et seq.* Subject matter jurisdiction is proper in this Court pursuant to 28 U.S.C. §§ 1331 and 1338.

6. Personal jurisdiction and venue are proper in this district under 28 U.S.C. §§ 1391 and 1400(b). Upon information and belief, Defendants Huawei China, Huawei Enterprise and Huawei Technologies USA Inc. established minimum contacts with this forum such that the exercise of jurisdiction over Defendants would not offend traditional notions of fair play and substantial justice. Upon information and belief, Defendants regularly conduct business in the State of Texas and in this judicial district and are subject to the jurisdiction of this Court. Upon information and belief, Defendants have been doing business in Texas and this judicial district by distributing, marketing, selling and/or offering for sale its products, including, but not limited to, products that practice the subject matter claimed in the Patents-In-Suit, and/or regularly doing or soliciting business and/or engaging in other persistent courses of conduct in and/or directed to Texas and this judicial district.

COUNT 1: INFRINGEMENT OF U.S. PATENT NO. 6,425,035

7. Crossroads incorporates by reference the allegations set forth in the preceding paragraphs.

8. On July 23, 2002, United States Patent No. 6,425,035 (the "'035 Patent") was duly and legally issued. A true and correct copy of the '035 Patent is attached hereto as Exhibit A. Crossroads is the assignee and the owner of all right, title, and interest in and to the '035 Patent. The '035 Patent is entitled to a presumption of validity.

9. On information and belief, Defendants have directly infringed the '035 Patent. On information and belief, Defendant continues to directly infringe the '035 Patent.

10. Specifically, on information and belief, Defendants have directly infringed the '035 Patent by making, using, offering for sale, selling and/or importing into the United States certain of products including at least the following: OceanStor S2200T Storage System, OceanStor S6800T Storage System, OceanStor T Series Unified Storage Systems (including the OceanStor S2600T, OceanStor S5500T, OceanStor S5600T, OceanStor S5800T), OceanStor HVS85T Storage Systems, OceanStor HVS88T Storage Systems, OceanStor VIS6600T Storage Systems, OceanStor Dorado 2100 G2 Storage Systems, and OceanStor Dorado 5100 Storage Systems.

11. Further, on information and belief, Defendants have been and now are indirectly infringing by way of inducing infringement of the '035 Patent with knowledge of the '035 Patent by making, offering for sale, selling, importing into the United States, marketing, supporting, providing product instruction and/or advertising certain products, including the OceanStor S2200T Storage System, OceanStor S6800T Storage System, OceanStor T Series Unified Storage Systems (including the OceanStor S2600T, OceanStor S5500T, OceanStor S5600T, OceanStor S5800T), OceanStor HVS85T Storage Systems, OceanStor HVS88T Storage Systems, OceanStor VIS6600T Storage Systems, OceanStor Dorado 2100 G2 Storage Systems, and OceanStor Dorado 5100 Storage Systems, and Defendants knew that these actions were inducing end users to infringe the '035 Patent.

12. Further, on information and belief, Defendants have been and now are indirectly infringing by way of contributing to the infringement by end users of the '035 Patent by selling, offering to sell and/or importing into the United States components, including the OceanStor

S2200T Storage System, OceanStor S6800T Storage System, OceanStor T Series Unified Storage Systems (including the OceanStor S2600T, OceanStor S5500T, OceanStor S5600T, OceanStor S5800T) OceanStor HVS85T Storage Systems, OceanStor HVS88T Storage Systems, OceanStor VIS6600T Storage Systems, OceanStor Dorado 2100 G2 Storage Systems, and OceanStor Dorado 5100 Storage Systems, knowing the components to be especially made or especially adapted for use in the infringement of the '035 Patent. Such components are not a staple article or commodity of commerce suitable for substantial non-infringing uses.

13. Defendants have been on constructive and/or actual notice of the '035 Patent since at least as early as February 2012, and Defendants have not ceased their infringing activities. The infringement of the '035 Patent by Defendants has been and continues to be willful and deliberate.

14. Crossroads has been irreparably harmed by Defendants' acts of infringement of the '035 Patent, and will continue to be harmed unless and until Defendants' acts of infringement are enjoined and restrained by order of this Court.

15. As a result of the acts of infringement of the '035 Patent by Defendants, Crossroads has suffered and will continue to suffer damages in an amount to be proven at trial.

COUNT 2: INFRINGEMENT OF U.S. PATENT NO. 7,934,041

16. Crossroads incorporates by reference the allegations set forth in the preceding paragraphs.

17. On April 26, 2011, United States Patent No. 7,934,041 (the "'041 Patent") was duly and legally issued. A true and correct copy of the '041 Patent is attached hereto as Exhibit B. Crossroads is the assignee and the owner of all right, title, and interest in and to the '041 Patent. The '041 Patent is entitled to a presumption of validity.

18. On information and belief, Defendants have directly infringed the '041 Patent. On information and belief, Defendants continue to directly infringe the '041 Patent.

19. Specifically, on information and belief, Defendants have directly infringed the '041 Patent by making, using, offering for sale, selling and/or importing into the United States certain products including at least the following: OceanStor S2200T Storage System, OceanStor S6800T Storage System, OceanStor T Series Unified Storage Systems (including the OceanStor S2600T, OceanStor S5500T, OceanStor S5600T, OceanStor S5800T) OceanStor HVS85T Storage Systems, OceanStor HVS88T Storage Systems, OceanStor VIS6600T Storage Systems, OceanStor Dorado 2100 G2 Storage Systems, and OceanStor Dorado 5100 Storage Systems.

20. Further, upon information and belief, Defendants have been and now are indirectly infringing by way of inducing infringement of the '041 Patent with knowledge of the '041 Patent by making, offering for sale, selling, importing into the United States, marketing, supporting, providing product instruction and/or advertising certain products, including the OceanStor S2200T Storage System, OceanStor S6800T Storage System, OceanStor T Series Unified Storage Systems (including the OceanStor S2600T, OceanStor S5500T, OceanStor S5600T, OceanStor S5800T), OceanStor HVS85T Storage Systems, OceanStor HVS88T Storage Systems, OceanStor VIS6600T Storage Systems, OceanStor Dorado 2100 G2 Storage Systems, and OceanStor Dorado 5100 Storage Systems, and Defendant knew that these actions were inducing end users to infringe the '041 Patent.

21. Further, upon information and belief, Defendants have been and now are indirectly infringing by way of contributing to the infringement by end users of the '041 Patent by selling, offering to sell and/or importing into the United States components, OceanStor S2200T Storage System, OceanStor S6800T Storage System, OceanStor T Series Unified

Storage Systems (including the OceanStor S2600T, OceanStor S5500T, OceanStor S5600T, OceanStor S5800T), OceanStor HVS85T Storage Systems, OceanStor HVS88T Storage Systems, OceanStor VIS6600T Storage Systems, OceanStor Dorado 2100 G2 Storage Systems, and OceanStor Dorado 5100 Storage Systems, knowing the components to be especially made or especially adapted for use in the infringement of the '041 Patent. Such components are not a staple article or commodity of commerce suitable for substantial non-infringing uses.

22. Defendants have been on constructive and/or actual notice of the '041 Patent since at least as early as February 2012, and Defendants have not ceased the infringing activities. The infringement of the '041 Patent by Defendants has been and continues to be willful and deliberate.

23. Crossroads has been irreparably harmed by Defendants' acts of infringement of the '041 Patent, and will continue to be harmed unless and until Defendants' acts of infringement are enjoined and restrained by order of this Court.

24. As a result of the acts of infringement of the '041 Patent by Defendants, Crossroads has suffered and will continue to suffer damages in an amount to be proven at trial.

COUNT 3: INFRINGEMENT OF U.S. PATENT NO. 7,051,147

25. Crossroads incorporates by reference the allegations set forth in the preceding paragraphs.

26. On May 23, 2006, United States Patent No. 7,051,147 (the "'147 Patent'") was duly and legally issued. A true and correct copy of the '147 Patent is attached hereto as Exhibit C. Crossroads is the assignee and the owner of all right, title, and interest in and to the '147 Patent. The '147 Patent is entitled to a presumption of validity.

27. On information and belief, Defendants have directly infringed the '147 Patent. On information and belief, Defendants continue to directly infringe the '147 Patent.

28. Specifically, on information and belief, Defendants have directly infringed the '147 Patent by making, using, offering for sale, selling and/or importing into the United States certain products including at least the following: OceanStor S5600T Storage Systems, OceanStor S5800T Storage Systems, OceanStor S6800T Storage Systems, OceanStor VIS6600T Storage Systems.

29. Further, on information and belief, Defendants have been and now are indirectly infringing by way of inducing infringement of the '147 Patent with knowledge of the '147 Patent by making, offering for sale, selling, importing into the United States, marketing, supporting, providing product instruction and/or advertising certain products, including the OceanStor S5600T Storage Systems, OceanStor S5800T Storage Systems, OceanStor S6800T Storage Systems, OceanStor VIS6600T Storage Systems, and Defendants knew that these actions were inducing end users to infringe the '147 Patent.

30. Further, on information and belief, Defendants have been and now are indirectly infringing by way of contributing to the infringement by end users of the '147 Patent by selling, offering to sell and/or importing into the United States components, including OceanStor S5600T Storage Systems, OceanStor S5800T Storage Systems, OceanStor S6800T Storage Systems, OceanStor VIS6600T Storage Systems, knowing the components to be especially made or especially adapted for use in the infringement of the '147 Patent. Such components are not a staple article or commodity of commerce suitable for substantial non-infringing uses.

31. Defendants have been on constructive and/or actual notice of the '147 Patent since at least as early as February 2012, and Defendants have not ceased the infringing activities.

The infringement of the '147 Patent by Defendants has been and continues to be willful and deliberate.

32. Crossroads has been irreparably harmed by Defendants' acts of infringement of the '147 Patent, and will continue to be harmed unless and until Defendants' acts of infringement are enjoined and restrained by order of this Court.

33. As a result of the acts of infringement of the '147 Patent by Defendants, Crossroads has suffered and will continue to suffer damages in an amount to be proven at trial.

PRAYER FOR RELIEF

WHEREFORE, Crossroads requests this Court enter judgment as follows:

- A. That Defendants have infringed the '035 Patent;
- B. That such infringement of the '035 Patent by Defendants has been willful;
- C. That Defendants account for and pays to Crossroads all damages caused by the infringement of the '035 Patent;
- D. That Crossroads receive enhanced damages from Defendants in the form of treble damages, pursuant to 35 U.S.C. § 284 based on Defendants' willful infringement of the '035 Patent;
- E. That Crossroads be granted pre-judgment and post-judgment interest on the damages caused to it by reason of Defendants' infringement of the '035 Patent, including pre-judgment and post-judgment interest on any enhanced damages or attorneys' fees award;
- F. That Defendants have infringed the '041 Patent;
- G. That such infringement of the '041 Patent by Defendants has been willful;

TO: Mail Stop 8 Director of the U.S. Patent and Trademark Office P.O. Box 1450 Alexandria, VA 22313-1450	REPORT ON THE FILING OR DETERMINATION OF AN ACTION REGARDING A PATENT OR TRADEMARK
---	--

In Compliance with 35 U.S.C. § 290 and/or 15 U.S.C. § 1116 you are hereby advised that a court action has been filed in the U.S. District Court Western District of Texas, Austin Division on the following
 Trademarks or Patents. (the patent action involves 35 U.S.C. § 292.):

DOCKET NO. 1:13-cv-895-SS	DATE FILED 10/7/2013	U.S. DISTRICT COURT Western District of Texas, Austin Division
PLAINTIFF Crossroads Systems, Inc.		DEFENDANT Oracle Corporation
PATENT OR TRADEMARK NO.	DATE OF PATENT OR TRADEMARK	HOLDER OF PATENT OR TRADEMARK
1 see attached		
2 6,425,035		
3 7,934,041		
4 7,051,147		
5		

In the above—entitled case, the following patent(s)/ trademark(s) have been included:

DATE INCLUDED	INCLUDED BY	<input type="checkbox"/> Amendment <input type="checkbox"/> Answer <input type="checkbox"/> Cross Bill <input type="checkbox"/> Other Pleading
PATENT OR TRADEMARK NO.	DATE OF PATENT OR TRADEMARK	HOLDER OF PATENT OR TRADEMARK
1		
2		
3		
4		
5		

In the above—entitled case, the following decision has been rendered or judgement issued:

DECISION/JUDGEMENT

CLERK William G. Putnicki	(BY) DEPUTY CLERK <i>Dga Schroeder</i>	DATE 10/7/2013
------------------------------	---	-------------------

Copy 1—Upon initiation of action, mail this copy to Director Copy 3—Upon termination of action, mail this copy to Director
 Copy 2—Upon filing document adding patent(s), mail this copy to Director Copy 4—Case file copy

- F. That Defendant has infringed the '041 Patent;
- G. That such infringement of the '041 Patent by Defendant has been willful;
- H. That Defendant accounts for and pays to Crossroads all damages caused by the infringement of the '041 Patent;
- I. That Crossroads receive enhanced damages from Defendant in the form of treble damages, pursuant to 35 U.S.C. § 284 based on Defendant's willful infringement of the '041 Patent;
- J. That Crossroads be granted pre-judgment and post-judgment interest on the damages caused to it by reason of Defendant's infringement of the '041 Patent, including pre-judgment and post-judgment interest on any enhanced damages or attorneys' fees award;
- K. That Defendant has infringed the '147 Patent;
- L. That such infringement of the '147 Patent by Defendant has been willful;
- M. That Defendant accounts for and pays to Crossroads all damages caused by the infringement of the '147 Patent;
- N. That Crossroads receive enhanced damages from Defendant in the form of treble damages, pursuant to 35 U.S.C. § 284 based on Defendant's willful infringement of the '147 Patent;
- O. That Crossroads be granted pre-judgment and post-judgment interest on the damages caused to it by reason of Defendant's infringement of the '147 Patent, including pre-judgment and post-judgment interest on any enhanced damages or attorneys' fees award;

- P. That Defendant pay Crossroads all of Crossroads' reasonable attorneys' fees and expenses;
- Q. That costs be awarded to Crossroads;
- R. That Defendant, its agents, employees, representatives, successors and assigns, and those acting in privity or in concert with it, be preliminary and permanently enjoined from further infringement of the '035 Patent;
- S. That Defendant, its agents, employees, representatives, successors and assigns, and those acting in privity or in concert with it, be preliminary and permanently enjoined from further infringement of the '041 Patent;
- T. That Defendant, its agents, employees, representatives, successors and assigns, and those acting in privity or in concert with it, be preliminary and permanently enjoined from further infringement of the '147 Patent;
- U. That this is an exceptional case under 35 U.S.C. § 285; and
- V. That Crossroads be granted such other and further relief as the Court may deem just and proper under the circumstances.

DEMAND FOR JURY TRIAL

Crossroads hereby demands a trial by jury on all issues.

Dated: October 7, 2013

Respectfully submitted,

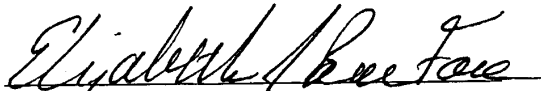
By: 

Steven Sprinkle
Texas Bar No. 00794962
Elizabeth J. Brown Fore
Texas Bar No. 24001795
Sprinkle IP Law Group, PC
1301 W. 25th Street, Suite 408
Austin, Texas 78705
Tel: 512-637-9220
Fax: 512-371-9088
ssprinkle@sprinklelaw.com
ebrownfore@sprinklelaw.com

Susan K. Knoll
Texas Bar No. 11616900
Russell R. Wong
Texas Bar No. 21884235
James H. Hall
Texas Bar No. 24041040
WONG, CABELLO, LUTSCH,
RUTHERFORD & BRUCCULERI, L.L.P.
20333 SH 249, Suite 600
Houston, TX 77070
Tel: 832-446-2400
Fax: 832-446-2424
sknoll@counselip.com
rwong@counselip.com
jhall@counselip.com

*ATTORNEYS FOR PLAINTIFF
CROSSROADS SYSTEMS, INC.*

IN THE UNITED STATES DISTRICT COURT
FOR THE WESTERN DISTRICT OF TEXAS
AUSTIN DIVISION

FILED
2013 OCT -7 PM 2:52
CLERK US DISTRICT COURT
WESTERN DISTRICT OF TEXAS

CROSSROADS SYSTEMS, INC.,

Plaintiff,

v.

ORACLE CORPORATION,

Defendant.

§
§
§
§
§
§
§
§
§
§
§

BY _____ OS

CIVIL ACTION NO. _____

JURY DEMANDED

A13CV0895 SS

**PLAINTIFF CROSSROADS SYSTEMS, INC.'S
COMPLAINT FOR PATENT INFRINGEMENT**

THE PARTIES

1. Plaintiff Crossroads Systems, Inc. ("Crossroads") is a corporation incorporated under the laws of the State of Delaware and has its principal place of business at 11000 North MoPac Expressway, Austin, Texas 78759.

2. Upon information and belief, Defendant Oracle Corporation ("Defendant") is a Delaware corporation with a principal place of business of 500 Oracle Parkway, Redwood City, CA 94065.

JURISDICTION AND VENUE

3. This action arises under the laws of the United States, more specifically under 35 U.S.C. § 100, *et seq.* Subject matter jurisdiction is proper in this Court pursuant to 28 U.S.C. §§ 1331 and 1338.

4. Personal jurisdiction and venue are proper in this district under 28 U.S.C. §§ 1391 and 1400(b). Upon information and belief, Defendant Oracle has established minimum contacts with this forum such that the exercise of jurisdiction over Defendant would not offend traditional notions of fair play and substantial justice.

5. This Court has personal jurisdiction over Oracle. Upon information and belief, Oracle regularly conducts business in the State of Texas and in this judicial district and is subject to the jurisdiction of this Court. Upon information and belief, Oracle has been doing business in Texas and this judicial district by distributing, marketing, selling and/or offering for sale its products, including, but not limited to, products that practice the subject matter claimed in the Patents-In-Suit, and/or regularly doing or soliciting business and/or engaging in other persistent courses of conduct in and/or directed to Texas and this judicial district.

COUNT 1: INFRINGEMENT OF U.S. PATENT NO. 6,425,035

6. Crossroads incorporates by reference the allegations set forth in the preceding paragraphs.

7. On July 23, 2002, United States Patent No. 6,425,035 (the "'035 Patent") was duly and legally issued. A true and correct copy of the '035 Patent is attached hereto as Exhibit A. Crossroads is the assignee and the owner of all right, title, and interest in and to the '035 Patent. The '035 Patent is entitled to a presumption of validity.

8. On information and belief, Defendant has directly infringed the '035 Patent. On information and belief, Defendant continues to directly infringe the '035 Patent.

9. Specifically, on information and belief, Defendant has directly infringed the '035 Patent by making, using, offering for sale, selling and/or importing into the United States certain of its products including at least the following: Sun ZFS Storage 7120 Appliance, Sun ZFS Storage 7320 Appliance, Sun ZFS Storage 7420 Appliance, Oracle Servers with Solaris with SCSI Target Mode Framework, Pillar Axiom 300 with Fibre Channel SAN Slammer, Pillar Axiom 300 with iSCSI SAN Slammer, Pillar Axiom 300 with Combination FC/iSCSI SAN Slammer, Pillar Axiom 600 with Fibre Channel SAN Slammer, Pillar Axiom 600 with iSCSI

SAN Slammer, Pillar Axiom 600 with Combination FC/iSCSI SAN Slammer, and Oracle Sun Storage 2540-M2 Array.

10. Further, on information and belief, Defendant has been and now is indirectly infringing by way of inducing infringement of the '035 Patent with knowledge of the '035 Patent by making, offering for sale, selling, importing into the United States, marketing, supporting, providing product instruction and/or advertising certain of its products, including the Sun ZFS Storage 7120 Appliance, Sun ZFS Storage 7320 Appliance, Sun ZFS Storage 7420 Appliance, Oracle Servers with Solaris with SCSI Target Mode Framework, Oracle Solaris with SCSI Target Mode Framework, Pillar Axiom 300 with Fibre Channel SAN Slammer, Pillar Axiom 300 with iSCSI SAN Slammer, Pillar Axiom 300 with Combination FC/iSCSI SAN Slammer, Pillar Axiom 600 with Fibre Channel SAN Slammer, Pillar Axiom 600 with iSCSI SAN Slammer, Pillar Axiom 600 with Combination FC/iSCSI SAN Slammer, and Oracle Sun Storage 2540-M2 Array, and Defendant knew that its actions were inducing end users to infringe the '035 Patent.

11. Further, on information and belief, Defendant has been and now is indirectly infringing by way of contributing to the infringement by end users of the '035 Patent by selling, offering to sell and/or importing into the United States components, including the Sun ZFS Storage 7120 Appliance, Sun ZFS Storage 7320 Appliance, Sun ZFS Storage 7420 Appliance, Oracle Servers with Solaris with SCSI Target Mode Framework, Oracle Solaris with SCSI Target Mode Framework, Pillar Axiom 300 with Fibre Channel SAN Slammer, Pillar Axiom 300 with iSCSI SAN Slammer, Pillar Axiom 300 with Combination FC/iSCSI SAN Slammer, Pillar Axiom 600 with Fibre Channel SAN Slammer, Pillar Axiom 600 with iSCSI SAN Slammer, Pillar Axiom 600 with Combination FC/iSCSI SAN Slammer, and Oracle Sun Storage

2540-M2 Array, knowing the components to be especially made or especially adapted for use in the infringement of the '035 Patent. Such components are not a staple article or commodity of commerce suitable for substantial non-infringing uses.

12. Defendant has been on constructive and/or actual notice of the '035 Patent since at least as early as November 2009, and Defendant has not ceased its infringing activities. The infringement of the '035 Patent by Defendant has been and continues to be willful and deliberate.

13. Crossroads has been irreparably harmed by Defendant's acts of infringement of the '035 Patent, and will continue to be harmed unless and until Defendant's acts of infringement are enjoined and restrained by order of this Court.

14. As a result of the acts of infringement of the '035 Patent by Defendant, Crossroads has suffered and will continue to suffer damages in an amount to be proven at trial.

COUNT 2: INFRINGEMENT OF U.S. PATENT NO. 7,934,041

15. Crossroads incorporates by reference the allegations set forth in the preceding paragraphs.

16. On April 26, 2011, United States Patent No. 7,934,041 (the "'041 Patent") was duly and legally issued. A true and correct copy of the '041 Patent is attached hereto as Exhibit B. Crossroads is the assignee and the owner of all right, title, and interest in and to the '041 Patent. The '041 Patent is entitled to a presumption of validity.

17. On information and belief, Defendant has directly infringed the '041 Patent. On information and belief, Defendant continues to directly infringe the '041 Patent.

18. Specifically, on information and belief, Defendant has directly infringed the '041 Patent by making, using, offering for sale, selling and/or importing into the United States certain of its products including at least the following: Sun ZFS Storage 7120 Appliance, Sun ZFS

Storage 7320 Appliance, Sun ZFS Storage 7420 Appliance, Oracle Servers with Solaris with SCSI Target Mode Framework, Pillar Axiom 300 with Fibre Channel SAN Slammer, Pillar Axiom 300 with iSCSI SAN Slammer, Pillar Axiom 300 with Combination FC/iSCSI SAN Slammer, Pillar Axiom 600 with Fibre Channel SAN Slammer, Pillar Axiom 600 with iSCSI SAN Slammer, Pillar Axiom 600 with Combination FC/iSCSI SAN Slammer, and Oracle Sun Storage 2540-M2 Array.

19. Further, upon information and belief, Defendant has been and now is indirectly infringing by way of inducing infringement of the '041 Patent with knowledge of the '041 Patent by making, offering for sale, selling, importing into the United States, marketing, supporting, providing product instruction and/or advertising certain of its products, including the Sun ZFS Storage 7120 Appliance, Sun ZFS Storage 7320 Appliance, Sun ZFS Storage 7420 Appliance, Oracle Servers with Solaris with SCSI Target Mode Framework, Oracle Solaris with SCSI Target Mode Framework, Pillar Axiom 300 with Fibre Channel SAN Slammer, Pillar Axiom 300 with iSCSI SAN Slammer, Pillar Axiom 300 with Combination FC/iSCSI SAN Slammer, Pillar Axiom 600 with Fibre Channel SAN Slammer, Pillar Axiom 600 with iSCSI SAN Slammer, Pillar Axiom 600 with Combination FC/iSCSI SAN Slammer, and Oracle Sun Storage 2540-M2 Array, and Defendant knew that its actions were inducing end users to infringe the '041 Patent.

20. Further, upon information and belief, Defendant has been and now is indirectly infringing by way of contributing to the infringement by end users of the '041 Patent by selling, offering to sell and/or importing into the United States components, including the Sun ZFS Storage 7120 Appliance, Sun ZFS Storage 7320 Appliance, Sun ZFS Storage 7420 Appliance, Oracle Servers with Solaris with SCSI Target Mode Framework, Oracle Solaris with SCSI

Target Mode Framework, Pillar Axiom 300 with Fibre Channel SAN Slammer, Pillar Axiom 300 with iSCSI SAN Slammer, Pillar Axiom 300 with Combination FC/iSCSI SAN Slammer, Pillar Axiom 600 with Fibre Channel SAN Slammer, Pillar Axiom 600 with iSCSI SAN Slammer, Pillar Axiom 600 with Combination FC/iSCSI SAN Slammer, and Oracle Sun Storage 2540-M2 Array, knowing the components to be especially made or especially adapted for use in the infringement of the '041 Patent. Such components are not a staple article or commodity of commerce suitable for substantial non-infringing uses.

21. Defendant has been on constructive and/or actual notice of the '041 Patent since at least as early as May 2011, and Defendant has not ceased its infringing activities. The infringement of the '041 Patent by Defendant has been and continues to be willful and deliberate.

22. Crossroads has been irreparably harmed by Defendant's acts of infringement of the '041 Patent, and will continue to be harmed unless and until Defendant's acts of infringement are enjoined and restrained by order of this Court.

23. As a result of the acts of infringement of the '041 Patent by Defendant, Crossroads has suffered and will continue to suffer damages in an amount to be proven at trial.

COUNT 3: INFRINGEMENT OF U.S. PATENT NO. 7,051,147

24. Crossroads incorporates by reference the allegations set forth in the preceding paragraphs.

25. On May 23, 2006, United States Patent No. 7,051,147 (the "'147 Patent") was duly and legally issued. A true and correct copy of the '147 Patent is attached hereto as Exhibit C. Crossroads is the assignee and the owner of all right, title, and interest in and to the '147 Patent. The '147 Patent is entitled to a presumption of validity.

26. On information and belief, Defendant has directly infringed the '147 Patent. On information and belief, Defendant continues to directly infringe the '147 Patent.

27. Specifically, on information and belief, Defendant has directly infringed the '147 Patent by making, using, offering for sale, selling and/or importing into the United States certain of its products including at least the following: Pillar Axiom 300 with Fibre Channel SAN Slammer, Pillar Axiom 300 with Combination FC/iSCSI SAN Slammer, Pillar Axiom 600 with Fibre Channel SAN Slammer, and the Pillar Axiom 600 with Combination FC/iSCSI SAN Slammer.

28. Further, on information and belief, Defendant has been and now is indirectly infringing by way of inducing infringement of the '147 Patent with knowledge of the '147 Patent by making, offering for sale, selling, importing into the United States, marketing, supporting, providing product instruction and/or advertising certain of its products, including the Pillar Axiom 300 with Fibre Channel SAN Slammer, Pillar Axiom 300 with Combination FC/iSCSI SAN Slammer, Pillar Axiom 600 with Fibre Channel SAN Slammer, and the Pillar Axiom 600 with Combination FC/iSCSI SAN Slammer, and Defendant knew that its actions were inducing end users to infringe the '147 Patent.

29. Further, on information and belief, Defendant has been and now is indirectly infringing by way of contributing to the infringement by end users of the '147 Patent by selling, offering to sell and/or importing into the United States components, including the Pillar Axiom 300 with Fibre Channel SAN Slammer, Pillar Axiom 300 with Combination FC/iSCSI SAN Slammer, Pillar Axiom 600 with Fibre Channel SAN Slammer, and the Pillar Axiom 600 with Combination FC/iSCSI SAN Slammer, knowing the components to be especially made or

especially adapted for use in the infringement of the '147 Patent. Such components are not a staple article or commodity of commerce suitable for substantial non-infringing uses.

30. Defendant has been on constructive and/or actual notice of the '147 Patent since at least as early as November 2009, and Defendant has not ceased its infringing activities. The infringement of the '147 Patent by Defendant has been and continues to be willful and deliberate.

31. Crossroads has been irreparably harmed by Defendant's acts of infringement of the '147 Patent, and will continue to be harmed unless and until Defendant's acts of infringement are enjoined and restrained by order of this Court.

32. As a result of the acts of infringement of the '147 Patent by Defendant, Crossroads has suffered and will continue to suffer damages in an amount to be proven at trial.

PRAYER FOR RELIEF

WHEREFORE, Crossroads requests this Court enter judgment as follows:

- A. That Defendant has infringed the '035 Patent;
- B. That such infringement of the '035 Patent by Defendant has been willful;
- C. That Defendant accounts for and pays to Crossroads all damages caused by the infringement of the '035 Patent;
- D. That Crossroads receive enhanced damages from Defendant in the form of treble damages, pursuant to 35 U.S.C. § 284 based on Defendant's willful infringement of the '035 Patent;
- E. That Crossroads be granted pre-judgment and post-judgment interest on the damages caused to it by reason of Defendant's infringement of the '035 Patent, including pre-judgment and post-judgment interest on any enhanced damages or attorneys' fees award;

TO: Mail Stop 8 Director of the U.S. Patent and Trademark Office P.O. Box 1450 Alexandria, VA 22313-1450	REPORT ON THE FILING OR DETERMINATION OF AN ACTION REGARDING A PATENT OR TRADEMARK
---	---

In Compliance with 35 U.S.C. § 290 and/or 15 U.S.C. § 1116 you are hereby advised that a court action has been filed in the U.S. District Court Western District of Texas, Austin Division on the following

Trademarks or Patents. (the patent action involves 35 U.S.C. § 292.):

DOCKET NO. 1:12-CV-104 SS	DATE FILED 2/1/2012	U.S. DISTRICT COURT Western District of Texas, Austin Division
PLAINTIFF Crossroads Systems, Inc.		DEFENDANT Infortrend Corporation; Aberdeen LLC; Boost Systems, Inc.; iXsystems, Inc.; and Storageflex, Inc.
PATENT OR TRADEMARK NO.	DATE OF PATENT OR TRADEMARK	HOLDER OF PATENT OR TRADEMARK
1 see attached		
2 6,425,035		
3 7,051,147		
4 7,934,041		
5 7,934,040		

In the above—entitled case, the following patent(s)/ trademark(s) have been included:

DATE INCLUDED	INCLUDED BY	<input type="checkbox"/> Amendment <input type="checkbox"/> Answer <input type="checkbox"/> Cross Bill <input type="checkbox"/> Other Pleading
PATENT OR TRADEMARK NO.	DATE OF PATENT OR TRADEMARK	HOLDER OF PATENT OR TRADEMARK
1 7,987,311		
2		
3		
4		
5		

In the above—entitled case, the following decision has been rendered or judgement issued:

DECISION/JUDGEMENT

CLERK William G. Putnicki	(BY) DEPUTY CLERK <i>Debra Schroed</i>	DATE 2/2/2012
------------------------------	---	------------------

Copy 1—Upon initiation of action, mail this copy to Director Copy 3—Upon termination of action, mail this copy to Director
 Copy 2—Upon filing document adding patent(s), mail this copy to Director Copy 4—Case file copy

infringement, by way of actively inducing infringement and/or contributing to the infringement of the '147 Patent by users of Defendant Boost products, such as EonStor Fibre-to-Fibre RAID Systems by, among other things, making, using, offering for sale, selling, importing into the United States, marketing, supporting, providing product instruction, and/or advertising certain of its products, including the EonStor Fibre-to-Fibre RAID Systems.

32. Further, Defendant Storageflex has been and now is indirectly infringing the '147 Patent, with knowledge of the patent and knowledge that its induced acts constitute patent infringement, by way of actively inducing infringement and/or contributing to the infringement of the '147 Patent by users of Defendant Storageflex's products, such as the FF1124 by, among other things, making, using, offering for sale, selling, importing into the United States, marketing, supporting, promoting, providing product instruction, and/or advertising certain of its products and/or certain components for use with Storageflex's products, including the FF1124 and/or components for use with same.

33. Defendants Infortrend, Boost and Storageflex have been on notice of the '147 Patent since before this lawsuit through notification by letter (Boost, Storageflex), prior involvement in litigation involving the '147 Patent (Infortrend), and/or purchase of a marked product (Storageflex), and have not ceased their infringing activities. The infringement of the '147 Patent by Defendants Infortrend, Boost and Storageflex has been and continues to be willful and deliberate.

34. Crossroads has been irreparably harmed by each of Defendant Infortrend's, Boost's and Storageflex's acts of infringement of the '147 Patent and will continue to be harmed unless and until each of Defendant Infortrend's, Boost's and Storageflex's acts of infringement are enjoined and restrained by order of this Court.

35. As a result of the acts of infringement of the '147 Patent by Defendants Infortrend, Boost and Storageflex, Crossroads has suffered and will continue to suffer damages in an amount to be proven at trial.

COUNT 3: INFRINGEMENT OF U.S. PATENT NO. 7,934,041

36. Crossroads incorporates by reference the allegations set forth in the preceding paragraphs.

37. On April 26, 2011, United States Patent No. 7,934,041 (the "'041 Patent'") was duly and legally issued. A true and correct copy of the '041 Patent is attached hereto as Exhibit C. Crossroads is the assignee and the owner of all right, title, and interest in and to the '041 Patent. The '041 Patent is entitled to a presumption of validity.

38. Defendants Infortrend, Aberdeen, Boost, iXsystems and Storageflex have directly infringed the '041 Patent. On information and belief, the Defendants continue to directly infringe the '041 Patent.

39. Specifically, each of the Defendants has directly infringed the '041 Patent by making, using, offering for sale, selling and/or importing into the United States certain of their products including at least the following: EonStor RAID Systems with Fibre Host Interface and/or iSCSI Host Interface, EonStor DS RAID Systems with Fibre Host Interface and/or iSCSI Host Interface, ESVA iSCSI Host Series and ESVA Fibre Host Series (Infortrend); XDAS D-Series RAID Systems with FC and/or iSCSI Host, XDAS iSCSI Series RAID Systems, XDAS F8 Series RAID Systems and Aberdeen P8 XDAS with Fibre Host Interface (Aberdeen); EonStor RAID Systems with Fibre Host Interface and/or iSCSI Host Interface, EonStor DS RAID Systems with Fibre Host Interface and/or iSCSI Host Interface, ESVA iSCSI Host Series and ESVA Fibre Host Series (Boost); Titan 316F, Titan 424F, ESVA iSCSI Host Series and

ESVA Fibre Host Series (iXsystems); and FF1124 and HA3969 with FC or iSCSI Host Interfaces (Storageflex).

40. Further, Defendant Aberdeen has been and now is indirectly infringing the '041 Patent, with knowledge of the patent and knowledge that its induced acts constitute patent infringement, by way of actively inducing infringement and/or contributing to the infringement of the '041 Patent by users of Defendant Aberdeen's products, such as XDAS D-Series RAID Systems with FC and/or iSCSI Host, XDAS iSCSI Series RAID Systems, XDAS F8 Series RAID Systems and Aberdeen P8 XDAS with Fibre Host Interface by among other things, making, using, offering for sale, selling, importing into the United States, marketing, supporting, providing product instruction, and/or advertising certain of Defendant Aberdeen's products, including XDAS D-Series RAID Systems with FC and/or iSCSI Host, XDAS iSCSI Series RAID Systems, XDAS F8 Series RAID Systems and Aberdeen P8 XDAS with Fibre Host Interface.

41. Further, Defendant Boost has been and now is indirectly infringing the '041 Patent, with knowledge of the patent and knowledge that its induced acts constitute patent infringement, by way of actively inducing infringement and/or contributing to the infringement of the '041 Patent by users of Defendant Boost's products, such as EonStor RAID Systems with Fibre Host Interface and/or iSCSI Host Interface, EonStor DS RAID Systems with Fibre Host Interface and/or iSCSI Host Interface, ESVA iSCSI Host Series, and ESVA Fibre Host Series by among other things, making, using, offering for sale, selling, importing into the United States, marketing, supporting, providing product instruction, and/or advertising certain of Defendant Boost's products, including the EonStor RAID Systems with Fibre Host Interface and/or iSCSI

Host Interface, EonStor DS RAID Systems with Fibre Host Interface and/or iSCSI Host Interface, ESVA iSCSI Host Series, and ESVA Fibre Host Series.

42. Further, Defendant iXsystems has been and now is indirectly infringing the '041 Patent, with knowledge of the patent, by way of contributing to the infringement of the '041 Patent by users of Defendant iXsystems' products, such as Titan 316F, Titan 424F, ESVA iSCSI Host Series, and ESVA Fibre Host Series by among other things, offering for sale, selling, and/or importing into the United States certain of Defendant iXsystems' products, including Titan 316F, Titan 424F, ESVA iSCSI Host Series, and/or ESVA Fibre Host Series.

43. Further, Defendant Storageflex has been and now is indirectly infringing the '041 Patent, with knowledge of the patent and knowledge that its induced acts constitute patent infringement, by way of actively inducing infringement and/or contributing to the infringement of the '041 Patent by users of Defendant Storageflex's products, such as the FF1124 and HA3969 with FC or iSCSI Host Interfaces by among other things, making, using, offering for sale, selling, importing into the United States, marketing, supporting, promoting, providing product instruction, and/or advertising certain of Defendant Storageflex's products and/or components for use with same, including, without limitation, the FF1124 and HA3969 with FC or iSCSI Host Interfaces and/or components for use with same.

44. Defendants Aberdeen, Boost, iXsystems and Storageflex have been on notice of the '041 Patent since before this lawsuit through notification by letter that their products, including, but not limited to, the infringing products listed herein, have infringed and continue to infringe the '041 Patent, and have not ceased their infringing activities. The infringement of the '041 Patent by Defendants Aberdeen, Boost, iXsystems and Storageflex has been and continues to be willful and deliberate.

45. Crossroads has been irreparably harmed by each of Defendant Infortrend's, Boost's, Aberdeen's, iXsystems' and Storageflex's acts of infringement of the '041 Patent, and will continue to be harmed unless and until of Defendant Infortrend's, Boost's, Aberdeen's, iXsystems' and Storageflex's acts of infringement are enjoined and restrained by order of this Court.

46. As a result of the acts of infringement of the '041 Patent by Defendants, Crossroads has suffered and will continue to suffer damages in an amount to be proven at trial.

COUNT 4: INFRINGEMENT OF U.S. PATENT NO. 7,934,040

47. Crossroads incorporates by reference the allegations set forth in the preceding paragraphs.

48. On April 26, 2011, United States Patent No. 7,934,040 (the "'040 Patent") was duly and legally issued. A true and correct copy of the '040 Patent is attached hereto as Exhibit D. Crossroads is the assignee and the owner of all right, title, and interest in and to the '040 Patent. The '040 Patent is entitled to a presumption of validity.

49. Defendants Infortrend, Aberdeen, Boost, iXsystems and Storageflex have each directly infringed the '040 Patent. On information and belief, each Defendant continues to directly infringe the '040 Patent.

50. Specifically, each of the Defendants has directly infringed the '040 Patent by making, using, offering for sale, selling and/or importing into the United States certain of their products including at least the following: EonStor RAID Systems with Fibre Host Interface and/or iSCSI Host Interface, EonStor DS RAID Systems with Fibre Host Interface and/or iSCSI Host Interface, ESVA iSCSI Host Series and ESVA Fibre Host Series (Infortrend); XDAS D-Series RAID Systems with FC and/or iSCSI Host, XDAS iSCSI Series RAID Systems, XDAS

F8 Series RAID Systems and Aberdeen P8 XDAS with Fibre Host Interface (Aberdeen); EonStor RAID Systems with Fibre Host Interface and/or iSCSI Host Interface, EonStor DS RAID Systems with Fibre Host Interface and/or iSCSI Host Interface, ESVA iSCSI Host Series and ESVA Fibre Host Series (Boost); Titan 316F, Titan 424F, ESVA iSCSI Host Series and ESVA Fibre Host Series (iXsystems); and FF1124 and HA3969 FC or iSCSI Host Interfaces (Storageflex).

51. Further, Defendant Aberdeen has been and now is indirectly infringing the '040 Patent, with knowledge of the patent and knowledge that its induced acts constitute patent infringement, by way of actively inducing infringement and/or contributing to the infringement of the '040 Patent by users of Defendant Aberdeen's products, such as XDAS D-Series RAID Systems with FC and/or iSCSI Host, XDAS iSCSI Series RAID Systems, XDAS F8 Series RAID Systems and Aberdeen P8 XDAS with Fibre Host Interface by among other things, making, using, offering for sale, selling, importing into the United States, marketing, supporting, providing product instruction, and/or advertising certain of Defendant Aberdeen's products, including XDAS D-Series RAID Systems with FC and/or iSCSI Host, XDAS iSCSI Series RAID Systems, XDAS F8 Series RAID Systems and Aberdeen P8 XDAS with Fibre Host Interface.

52. Further, Defendant Boost has been and now is indirectly infringing the '040 Patent, with knowledge of the patent and knowledge that its induced acts constitute patent infringement, by way of actively inducing infringement and/or contributing to the infringement of the '040 Patent by users of Defendant Boost's products, such as EonStor RAID Systems with Fibre Host Interface and/or iSCSI Host Interface, EonStor DS RAID Systems with Fibre Host Interface and/or iSCSI Host Interface, ESVA iSCSI Host Series, and ESVA Fibre Host Series by

among other things, making, using, offering for sale, selling, importing into the United States, marketing, supporting, providing product instruction, and/or advertising certain of Defendant Boost's products, including the EonStor RAID Systems with Fibre Host Interface and/or iSCSI Host Interface, EonStor DS RAID Systems with Fibre Host Interface and/or iSCSI Host Interface, ESVA iSCSI Host Series, and ESVA Fibre Host Series.

53. Further, Defendant iXsystems has been and now is indirectly infringing the '040 Patent, with knowledge of the patent, by way of contributing to the infringement of the '040 Patent by users of Defendant iXsystems' products, such as the Titan 316F, Titan 424F, ESVA iSCSI Host Series and ESVA Fibre Host Series by among other things, offering for sale, selling, and/or importing into the United States certain of Defendant iXsystems' products, including the Titan 316F, Titan 424F, ESVA iSCSI Host Series and ESVA Fibre Host Series.

54. Further, Defendant Storageflex has been and now is indirectly infringing the '040 Patent, with knowledge of the patent and knowledge that its induced acts constitute patent infringement, by way of actively inducing infringement and/or contributing to the infringement of the '040 Patent by users of Defendant Storageflex's products, such as the FF1124 and HA3969 with FC or iSCSI Host Interfaces by among other things, making, using, offering for sale, selling, importing into the United States, marketing, supporting, promoting, providing product instruction, and/or advertising certain of Defendant Storageflex's products and/or components for use with same, including, without limitation, the FF1124 and HA3969 with FC or iSCSI Host Interfaces and/or components for use with same.

55. Defendants Aberdeen, Boost, iXsystems and Storageflex have been on notice of the '040 Patent since before this lawsuit through notification by letter that their products, including, but not limited to, the infringing products listed herein, have infringed and continued

to infringe, and have not ceased their infringing activities. The infringement of the '040 Patent by Defendants Aberdeen, Boost, iXsystems and Storageflex has been and continues to be willful and deliberate.

56. Crossroads has been irreparably harmed by each of Defendant Storageflex's, Aberdeen's, iXsystems', Boost's and Infortrend's acts of infringement of the '040 Patent, and will continue to be harmed unless and until each of Defendant Storageflex's, Aberdeen's, iXsystems', Boost's and Infortrend's acts of infringement are enjoined and restrained by order of this Court.

57. As a result of the acts of infringement of the '040 Patent by Defendants, Crossroads has suffered and will continue to suffer damages in an amount to be proven at trial.

COUNT 5: INFRINGEMENT OF U.S. PATENT NO. 7,987,311

58. Crossroads incorporates by reference the allegations set forth in the preceding paragraphs.

59. On July 26, 2011, United States Patent No. 7,987,311 (the "'311 Patent'") was duly and legally issued. A true and correct copy of the '311 Patent is attached hereto as Exhibit E. Crossroads is the assignee and the owner of all right, title, and interest in and to the '311 Patent. The '311 Patent is entitled to a presumption of validity.

60. Defendants Infortrend, Aberdeen, Boost, iXsystems and Storageflex have each directly infringed the '311 Patent. On information and belief, each Defendant continues to directly infringe the '311 Patent.

61. Specifically, each of the Defendants has directly infringed the '311 Patent by making, using, offering for sale, selling and/or importing into the United States certain of their products including at least the following: EonStor RAID Systems with Fibre Host Interface

and/or iSCSI Host Interface, EonStor DS RAID Systems with Fibre Host Interface and/or iSCSI Host Interface, ESVA iSCSI Host Series and ESVA Fibre Host Series (Infortrend); XDAS D-Series RAID Systems with FC and/or iSCSI Host, XDAS iSCSI Series RAID Systems, XDAS F8 Series RAID Systems and Aberdeen P8 XDAS with Fibre Host Interface (Aberdeen); EonStor RAID Systems with Fibre Host Interface and/or iSCSI Host Interface, EonStor DS RAID Systems with Fibre Host Interface and/or iSCSI Host Interface, ESVA iSCSI Host Series and ESVA Fibre Host Series (Boost); Titan 316F, Titan 424F, ESVA iSCSI Host Series and ESVA Fibre Host Series (iXsystems); and FF1124 and HA3969 FC or iSCSI Host Interfaces (Storageflex).

62. Further, Defendant Boost has been and now is indirectly infringing the '311 Patent, with knowledge of the patent and knowledge that its induced acts constitute patent infringement, by way of actively inducing infringement and/or contributing to the infringement of the '311 Patent by users of Defendant Boost's products, such as EonStor RAID Systems with Fibre Host Interface and/or iSCSI Host Interface, EonStor DS RAID Systems with Fibre Host Interface and/or iSCSI Host Interface, ESVA iSCSI Host Series, and ESVA Fibre Host Series by among other things, making, using, offering for sale, selling, importing into the United States, marketing, supporting, providing product instruction, and/or advertising certain of Defendant Boost's products, including the EonStor RAID Systems with Fibre Host Interface and/or iSCSI Host Interface, EonStor DS RAID Systems with Fibre Host Interface and/or iSCSI Host Interface, ESVA iSCSI Host Series, and ESVA Fibre Host Series.

63. Further, Defendant Storageflex has been and now is indirectly infringing the '311 Patent, with knowledge of the patent and knowledge that its induced acts constitute patent infringement, by way of actively inducing infringement and/or contributing to the infringement

of the '311 Patent by users of Defendant Storageflex's products, such as the FF1124 and HA3969 with FC or iSCSI Host Interfaces by among other things, making, using, offering for sale, selling, importing into the United States, marketing, supporting, promoting, providing product instruction, and/or advertising certain of Defendant Storageflex's products and/or components for use with same, including, without limitation, the FF1124 and HA3969 with FC or iSCSI Host Interfaces and/or components for use with same.

64. Defendants Boost and Storageflex have been on notice of the '311 Patent since before this lawsuit through notification by letter that their products, including, but not limited to, the infringing products listed herein, have infringed and continued to infringe, and have not ceased their infringing activities. The infringement of the '311 Patent by Defendants Boost and Storageflex has been and continues to be willful and deliberate.

65. Crossroads has been irreparably harmed by each of Defendant Storageflex's, Aberdeen's, iXsystems', Boost's and Infortrend's acts of infringement of the '311 Patent, and will continue to be harmed unless and until each of Defendant Storageflex's, Aberdeen's, iXsystems', Boost's and Infortrend's acts of infringement are enjoined and restrained by order of this Court.

66. As a result of the acts of infringement of the '311 Patent by Defendants, Crossroads has suffered and will continue to suffer damages in an amount to be proven at trial.

PRAYER FOR RELIEF

WHEREFORE, Crossroads requests this Court enter judgment as follows:

- A. That each of the Defendants has infringed the '035 Patent;
- B. That such infringement of the '035 Patent by Defendants has been willful;

- C. That Defendants account for and pay to Crossroads all damages caused by the infringement of the '035 Patent;
- D. That Crossroads receive enhanced damages from Defendants in the form of treble damages, pursuant to 35 U.S.C. § 284 based on Defendants' willful infringement of the '035 Patent;
- E. That Crossroads be granted pre-judgment and post-judgment interest on the damages caused to it by reason of Defendants' infringement of the '035 Patent, including pre-judgment and post-judgment interest on any enhanced damages or attorneys' fees award;
- F. That Defendants Infortrend, Boost and Storageflex have infringed the '147 Patent;
- G. That such infringement of the '147 Patent by Defendants Infortrend, Boost and Storageflex has been willful;
- H. That Defendants Infortrend, Boost and Storageflex account for and pay to Crossroads all damages caused by the infringement of the '147 Patent;
- I. That Crossroads receive enhanced damages from Defendants Infortrend, Boost and Storageflex in the form of treble damages, pursuant to 35 U.S.C. § 284 based on Defendants Infortrend, Boost and Storageflex's willful infringement of the '147 Patent;
- J. That Crossroads be granted pre-judgment and post-judgment interest on the damages caused to it by reason of Defendants Infortrend, Boost and Storageflex's infringement of the '147 Patent, including pre-judgment and post-judgment interest on any enhanced damages or attorneys' fees award;

- K. That each of the Defendants has infringed the '041 Patent;
- L. That such infringement of the '041 Patent by Defendants Aberdeen, Boost, iXsystems and Storageflex has been willful;
- M. That Defendants account for and pay to Crossroads all damages caused by the infringement of the '041 Patent;
- N. That Crossroads receive enhanced damages from Defendants in the form of treble damages, pursuant to 35 U.S.C. § 284 based on each of Defendants Aberdeen's, Boost's, iXsystems' and Storageflex's willful infringement of the '041 Patent;
- O. That Crossroads be granted pre-judgment and post-judgment interest on the damages caused to it by reason of Defendants' infringement of the '041 Patent, including pre-judgment and post-judgment interest on any enhanced damages or attorneys' fees award;
- P. That each of the Defendants has infringed the '040 Patent;
- Q. That such infringement of the '040 Patent by Defendants Aberdeen, Boost, iXsystems and Storageflex has been willful;
- R. That Defendants account for and pay to Crossroads all damages caused by the infringement of the '040 Patent;
- S. That Crossroads receive enhanced damages from Defendants in the form of treble damages, pursuant to 35 U.S.C. § 284 based on each of Defendants Aberdeen's, Boost's, iXsystems' and Storageflex's willful infringement of the '040 Patent;

- T. That Crossroads be granted pre-judgment and post-judgment interest on the damages caused to it by reason of Defendants' infringement of the '040 Patent, including pre-judgment and post-judgment interest on any enhanced damages or attorneys' fees award;
- U. That each of the Defendants has infringed the '311 Patent;
- V. That such infringement of the '311 Patent by Defendants Boost and Storageflex has been willful;
- W. That Defendants account for and pay to Crossroads all damages caused by the infringement of the '311 Patent;
- X. That Crossroads receive enhanced damages from Defendants Boost and Storageflex in the form of treble damages, pursuant to 35 U.S.C. § 284 based on each of Defendants Boost's and Storageflex's willful infringement of the '311 Patent;
- Y. That Crossroads be granted pre-judgment and post-judgment interest on the damages caused to it by reason of Defendants' infringement of the '311 Patent, including pre-judgment and post-judgment interest on any enhanced damages or attorneys' fees award;
- Z. That Defendants pay Crossroads all of Crossroads' reasonable attorneys' fees and expenses;
- AA. That costs be awarded to Crossroads;
- BB. That Defendants, their agents, employees, representatives, successors and assigns, and those acting in privity or in concert with them, be preliminary and permanently enjoined from further infringement of the '035 Patent;

- CC. That Defendants Infortrend, Boost and Storageflex, their agents, employees, representatives, successors and assigns, and those acting in privity or in concert with them, be preliminary and permanently enjoined from further infringement of the '147 Patent;
- DD. That Defendants, their agents, employees, representatives, successors and assigns, and those acting in privity or in concert with them, be preliminary and permanently enjoined from further infringement of the '041 Patent;
- EE. That Defendants, their agents, employees, representatives, successors and assigns, and those acting in privity or in concert with them, be preliminary and permanently enjoined from further infringement of the '040 Patent;
- FF. That Defendants, their agents, employees, representatives, successors and assigns, and those acting in privity or in concert with them, be preliminary and permanently enjoined from further infringement of the '311 Patent;
- GG. That this is an exceptional case under 35 U.S.C. § 285; and
- HH. That Crossroads be granted such other and further relief as the Court may deem just and proper under the circumstances.

DEMAND FOR JURY TRIAL

Crossroads hereby demands a trial by jury on all issues.

Dated: February 1, 2012

Respectfully submitted,

By: /s/ Elizabeth J. Brown Fore
Steven Sprinkle
State Bar No. 00794962
Elizabeth J. Brown Fore
State Bar No. 24001795
Sprinkle IP Law Group, PC

1301 W. 25th Street, Suite 408
Austin, Texas 78705
Tel: (512) 637-9220
Fax: (512) 371-9088
ssprinkle@sprinklelaw.com
ebrownfore@sprinklelaw.com

5. Upon information and belief, Defendant iXsystems, Inc. (“iXsystems”) is a Delaware corporation with a principal place of business of 2490 Kruse Drive, San Jose, CA 95131.

6. Upon information and belief, Defendant Storageflex, Inc. (“Storageflex”) is an Ontario corporation with a principal place of business of 3601 Highway 7, Suite 400, Markham, Ontario L3R 0M3 Canada.

JURISDICTION AND VENUE

7. This action arises under the laws of the United States, more specifically under 35 U.S.C. § 100, *et seq.* Subject matter jurisdiction is proper in this Court pursuant to 28 U.S.C. §§ 1331 and 1338.

8. Personal jurisdiction and venue are proper in this district under 28 U.S.C. §§ 1391(c) and 1400. Upon information and belief, each Defendant has established minimum contacts with this forum such that the exercise of jurisdiction over each defendant would not offend traditional notions of fair play and substantial justice.

9. This Court has personal jurisdiction over Infortrend. Upon information and belief, Infortrend regularly conducts business in the State of Texas and in this judicial district and is subject to the jurisdiction of this Court. Upon information and belief, Infortrend has been doing business in Texas and this judicial district by distributing, marketing, selling and/or offering for sale its products, including, but not limited to, products that practice the subject matter claimed in the Patents-In-Suit, and/or regularly doing or soliciting business and/or engaging in other persistent courses of conduct in and/or directed to Texas and this judicial district.

10. This Court has personal jurisdiction over Aberdeen. Upon information and belief, Aberdeen regularly conducts business in the State of Texas and in this judicial district and is

subject to the jurisdiction of this Court. Upon information and belief, Aberdeen has been doing business in Texas and this judicial district by distributing, marketing, selling and/or offering for sale its products, and/or regularly doing or soliciting business and/or engaging in other persistent courses of conduct in and/or directed to Texas and this judicial district.

11. This Court has personal jurisdiction over Boost. Upon information and belief, Boost regularly conducts business in the State of Texas and in this judicial district and is subject to the jurisdiction of this Court. Upon information and belief, Boost has been doing business in Texas and this judicial district by distributing, marketing, selling and/or offering for sale its products, and/or regularly doing or soliciting business and/or engaging in other persistent courses of conduct in and/or directed to Texas and this judicial district.

12. This Court has personal jurisdiction over iXsystems. Upon information and belief, iXsystems regularly conducts business in the State of Texas and in this judicial district and is subject to the jurisdiction of this Court. Upon information and belief, iXsystems has been doing business in Texas and this judicial district by distributing, marketing, selling and/or offering for sale its products, and/or regularly doing or soliciting business and/or engaging in other persistent courses of conduct in and/or directed to Texas and this judicial district.

13. This Court has personal jurisdiction over Storageflex. Upon information and belief, Storageflex regularly conducts business in the State of Texas and in this judicial district and is subject to the jurisdiction of this Court. Upon information and belief, Storageflex has been doing business in Texas and this judicial district by distributing, marketing, selling and/or offering for sale its products, and/or regularly doing or soliciting business and/or engaging in other persistent courses of conduct in and/or directed to Texas and this judicial district. Further, Storageflex has engaged in activities in this judicial district relating to one or more products that

practice the subject matter claimed by at least one of the Patents-In-Suit by purchasing one or more products from this judicial district that were marked with at least one of the patents-in-suit.

COUNT 1: INFRINGEMENT OF U.S. PATENT NO. 6,425,035

14. Crossroads incorporates by reference the allegations set forth in the preceding paragraphs.

15. On July 23, 2002, United States Patent No. 6,425,035 (the "'035 Patent") was duly and legally issued. A true and correct copy of the '035 Patent is attached hereto as Exhibit A. Crossroads is the assignee and the owner of all right, title, and interest in and to the '035 Patent. The '035 Patent is entitled to a presumption of validity.

16. Defendants Infortrend, Aberdeen, Boost, iXsystems and Storageflex have each directly infringed the '035 Patent. On information and belief, each Defendant continues to directly infringe the '035 Patent.

17. Specifically, each of the Defendants has directly infringed the '035 Patent by making, using, offering for sale, selling and/or importing into the United States certain of their products including at least the following: EonStor RAID Systems with Fibre Host Interface and/or iSCSI Host Interface, EonStor DS RAID Systems with Fibre Host Interface and/or iSCSI Host Interface, ESVA iSCSI Host Series and ESVA Fibre Host Series (Infortrend); XDAS D-Series RAID Systems with FC and/or iSCSI Host, XDAS iSCSI Series RAID Systems, XDAS F8 Series RAID Systems and Aberdeen P8 XDAS with Fibre Host Interface (Aberdeen); EonStor RAID Systems with Fibre Host Interface and/or iSCSI Host Interface, EonStor DS RAID Systems with Fibre Host Interface and/or iSCSI Host Interface, ESVA iSCSI Host Series and ESVA Fibre Host Series (Boost); Titan 316F, Titan 424F, ESVA iSCSI Host Series, and

ESVA Fibre Host Series (iXsystems); and FF1124 and HA3969 with FC or iSCSI Host Interfaces (Storageflex).

18. Further, Defendant Infortrend has been and now is indirectly infringing the '035 Patent, with knowledge of the patent and knowledge that its induced acts constitute patent infringement, by way of actively inducing infringement and/or contributing to the infringement of the '035 Patent by users of Defendant Infortrend's products, such as EonStor RAID Systems with Fibre Host Interface and/or iSCSI Host Interface, EonStor DS RAID Systems with Fibre Host Interface and/or iSCSI Host Interface, ESVA iSCSI Host Series and ESVA Fibre Host Series, by among other things, making, using, offering for sale, selling, importing into the United States, marketing, supporting, promoting, providing product instruction, and/or advertising certain of Defendant Infortrend's products and/or Defendant Infortrend's components for use with same, including EonStor RAID Systems with Fibre Host Interface and/or iSCSI Host Interface, EonStor DS RAID Systems with Fibre Host Interface and/or iSCSI Host Interface, ESVA iSCSI Host Series and ESVA Fibre Host Series and/or components for use with same.

19. Further, Defendant Aberdeen has been and now is indirectly infringing the '035 Patent, with knowledge of the patent and knowledge that its induced acts constitute patent infringement, by way of actively inducing infringement and/or contributing to the infringement of the '035 Patent by users of Defendant Aberdeen's products, such as XDAS D-Series RAID Systems with FC and/or iSCSI Host, XDAS iSCSI Series RAID Systems, XDAS F8 Series RAID Systems and Aberdeen P8 XDAS with Fibre Host Interface by among other things, making, using, offering for sale, selling, importing into the United States, marketing, supporting, providing product instruction, and/or advertising certain of Defendant Aberdeen's products, including XDAS D-Series RAID Systems with FC and/or iSCSI Host, XDAS iSCSI Series

RAID Systems, XDAS F8 Series RAID Systems and Aberdeen P8 XDAS with Fibre Host Interface.

20. Further, Defendant Boost has been and now is indirectly infringing the '035 Patent, with knowledge of the patent and knowledge that its induced acts constitute patent infringement, by way of actively inducing infringement and/or contributing to the infringement of the '035 Patent by users of Defendant Boost's products, such as EonStor RAID Systems with Fibre Host Interface and/or iSCSI Host Interface, EonStor DS RAID Systems with Fibre Host Interface and/or iSCSI Host Interface, ESVA iSCSI Host Series, and ESVA Fibre Host Series by among other things, making, using, offering for sale, selling, importing into the United States, marketing, supporting, providing product instruction, and/or advertising certain of Defendant Boost's products, including the EonStor RAID Systems with Fibre Host Interface and/or iSCSI Host Interface, EonStor DS RAID Systems with Fibre Host Interface and/or iSCSI Host Interface, ESVA iSCSI Host Series, and ESVA Fibre Host Series.

21. Further, Defendant iXsystems has been and now is indirectly infringing the '035 Patent, with knowledge of the patent, by way of contributing to the infringement of the '035 Patent by users of Defendant iXsystems' products, such as the Titan 316F, Titan 424F, ESVA iSCSI Host Series and ESVA Fibre Host Series, by among other things, offering for sale, selling, and/or importing into the United States certain of Defendant iXsystems' products, including Titan 316F, Titan 424F, ESVA iSCSI Host Series, and/or ESVA Fibre Host Series.

22. Further, Defendant Storageflex has been and now is indirectly infringing the '035 Patent, with knowledge of the patent and knowledge that its induced acts constitute patent infringement, by way of actively inducing infringement and/or contributing to the infringement of the '035 Patent by users of Defendant Storageflex's products, such as the FF1124 and

HA3969 with FC or iSCSI Host Interfaces, by among other things, making, using, offering for sale, selling, importing into the United States, marketing, supporting, promoting, providing product instruction, and/or advertising certain of Defendant Storageflex's products and/or components for use with same, including the FF1124 and HA3969 with FC or iSCSI Host Interfaces and/or components for use with same.

23. Each Defendant has been on notice of the '035 Patent since before this lawsuit through prior involvement in litigation involving the '035 Patent (Infortrend), the purchase of a marked product (Storageflex) and/or through notification by letter that its products, including but not limited to the infringing products listed herein, have infringed and continue to infringe (Storageflex, Aberdeen, iXsystems, Boost), and no Defendant has ceased its infringing activities. The infringement of the '035 Patent by each Defendant has been and continues to be willful and deliberate.

24. Crossroads has been irreparably harmed by each of Defendant Infortrend's, Storageflex's, Aberdeen's, Boost's and iXsystems' acts of infringement of the '035 Patent, and will continue to be harmed unless and until each of Defendant Infortrend's, Storageflex's, Aberdeen's, Boost's and iXsystems' acts of infringement are enjoined and restrained by order of this Court.

25. As a result of the acts of infringement of the '035 Patent by Defendants, Crossroads has suffered and will continue to suffer damages in an amount to be proven at trial.

COUNT 2: INFRINGEMENT OF U.S. PATENT NO. 7,051,147

26. Crossroads incorporates by reference the allegations set forth in the preceding paragraphs.

27. On May 23, 2006, United States Patent No. 7,051,147 (the "'147 Patent") was duly and legally issued. A true and correct copy of the '147 Patent is attached hereto as Exhibit B. Crossroads is the assignee and the owner of all right, title, and interest in and to the '147 Patent. The '147 Patent is entitled to a presumption of validity.

28. Defendants Infortrend, Boost and Storageflex have directly infringed the '147 Patent and, on information and belief, Defendants Infortrend, Boost and Storageflex continue to directly infringe the '147 Patent.

29. Specifically, Defendants Infortrend, Boost and Storageflex have directly infringed the '147 Patent by making, using, offering for sale, selling and/or importing into the United States certain of their products including at least the following: EonStor Fibre-to-Fibre RAID Systems and EonStor DS Fibre-to-Fibre RAID Systems (Infortrend); EonStor Fibre-to-Fibre RAID Systems (Boost); and FF1124 (Storageflex).

30. Further, Defendant Infortrend has been and now is indirectly infringing the '147 Patent, with knowledge of the patent and knowledge that its induced acts constitute patent infringement, by way of actively inducing infringement and/or contributing to the infringement of the '147 Patent by users of Defendant Infortrend's products, such as EonStor Fibre-to-Fibre RAID Systems and EonStor DS Fibre-to-Fibre RAID Systems by, among other things, making, using, offering for sale, selling, importing into the United States, marketing, supporting, promoting, providing product instruction, and/or advertising certain of its products and/or Defendant Infortrend's components for use with same, including EonStor Fibre-to-Fibre RAID Systems, EonStor DS Fibre-to-Fibre RAID Systems and/or components for use with same.

31. Further, Defendant Boost has been and now is indirectly infringing the '147 Patent, with knowledge of the patent and knowledge that its induced acts constitute patent

TO: Mail Stop 8 Director of the U.S. Patent and Trademark Office P.O. Box 1450 Alexandria, VA 22313-1450	REPORT ON THE FILING OR DETERMINATION OF AN ACTION REGARDING A PATENT OR TRADEMARK
---	---

In Compliance with 35 U.S.C. § 290 and/or 15 U.S.C. § 1116 you are hereby advised that a court action has been filed in the U.S. District Court WD/TX, Austin Division on the following Patents or Trademarks:

DOCKET NO. 1:09-cv-879-SS	DATE FILED December 7, 2009	U.S. DISTRICT COURT Western District of Texas, Austin Division
PLAINTIFF Crossroads Systems, Inc.		DEFENDANT (1) Postvision, Inc., (2) Celeros Corporation (3) Digilink Technologies (4) Ciphermax, Inc. (5) Intransa, Inc. (6) Rasiliant Systems, Inc. (7) Qlogic Corporation (8) Overland Storage, Inc.
PATENT OR TRADEMARK NO.	DATE OF PATENT OR TRADEMARK	HOLDER OF PATENT OR TRADEMARK
1 6,425,035		
2 7,051,147		
3		
4		
5		

In the above—entitled case, the following patent(s)/ trademark(s) have been included:

DATE INCLUDED	INCLUDED BY <input type="checkbox"/> Amendment <input type="checkbox"/> Answer <input type="checkbox"/> Cross Bill <input type="checkbox"/> Other Pleading		
PATENT OR TRADEMARK NO.	DATE OF PATENT OR TRADEMARK	HOLDER OF PATENT OR TRADEMARK	
1			
2			
3			
4			
5			

In the above—entitled case, the following decision has been rendered or judgement issued:

DECISION/JUDGEMENT See attached Final Judgment

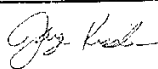
CLERK William G. Putnicki	(BY) DEPUTY CLERK 	DATE 12/23/2010
------------------------------	---	--------------------

Copy 1—Upon initiation of action, mail this copy to Director Copy 3—Upon termination of action, mail this copy to Director
 Copy 2—Upon filing document adding patent(s), mail this copy to Director Copy 4—Case file copy

IT IS FURTHER ORDERED, ADJUDGED, and DECREED that

1. CipherMax, Inc. has infringed United States Patent No. 6,425,035 (the "'035 Patent") and United States Patent No. 7,051,147 (the "'147 Patent");
2. CipherMax's infringement of the '035 Patent and the '147 Patent was willful;
3. CipherMax shall pay Crossroads' attorneys' fees in the amount of THIRTEEN THOUSAND, EIGHT HUNDRED, AND SIXTY FIVE DOLLARS (\$13,865.00)
4. CipherMax, its agents, employees, representatives, successors and assigns, and those acting in privity or in consort with CipherMax are permanently enjoined from further infringement of the '035 Patent and the '147 Patent by making, using, offering to sell or selling in the United States, or importing into the United States, any unlicensed products, including, without limitation, the CM Family storage systems, (including the CM1800, CM200T, CM200D, CM250, and CM 500 products) either alone or in combination with any other product;
5. CipherMax is required to provide notice of the injunction herein to its officers, directors, agents, servants, representatives, attorneys, employees, subsidiaries and affiliates, and those persons in active consort or participation with them;
6. CipherMax is required to employ whatever means are necessary or appropriate to ensure compliance with this final judgment; and
7. This permanent injunction shall be in effect until the expiration of the '035 Patent and the '147 Patent.

IT IS FINALLY ORDERED, ADJUDGED, and DECREED that all costs of suit are
taxed against each party incurring the same.

SIGNED this the 22nd day of December 2010.



SAM SPARKS
UNITED STATES DISTRICT JUDGE

AO 120 (Rev. 3/04)

TO: Mail Stop 8 Director of the U.S. Patent and Trademark Office P.O. Box 1450 Alexandria, VA 22313-1450	REPORT ON THE FILING OR DETERMINATION OF AN ACTION REGARDING A PATENT OR TRADEMARK
---	--

In Compliance with 35 U.S.C. § 290 and/or 15 U.S.C. § 1116 you are hereby advised that a court action has been filed in the U.S. District Court _____ on the following Patents or Trademarks:

DOCKET NO. 1:08-cv-861-SS	DATE FILED November 24, 2008	U.S. DISTRICT COURT US District Court, Western District of Texas, Austin Division
PLAINTIFF Crossroads Systems, Inc.		DEFENDANT DataDirect Networks, Inc., et al
PATENT OR TRADEMARK NO.	DATE OF PATENT OR TRADEMARK	HOLDER OF PATENT OR TRADEMARK
1		
2		
3	6,425,035	
4	7,051,147	
5		

In the above-entitled case, the following patent(s)/ trademark(s) have been included:

DATE INCLUDED	INCLUDED BY	<input type="checkbox"/> Amendment	<input type="checkbox"/> Answer	<input type="checkbox"/> Cross Bill	<input type="checkbox"/> Other Pleading
PATENT OR TRADEMARK NO.	DATE OF PATENT OR TRADEMARK	HOLDER OF PATENT OR TRADEMARK			
1					
2					
3					
4					
5					

In the above-entitled case, the following decision has been rendered or judgement issued:

DECISION/JUDGEMENT <i>Please see attached Final Judgment.</i>
--

CLERK William G. Putnicki	(BY) DEPUTY CLERK <i>Mary Chausson</i>	DATE MAR 17 2010
------------------------------	---	---------------------

Copy 1—Upon initiation of action, mail this copy to Director Copy 3—Upon termination of action, mail this copy to Director
 Copy 2—Upon filing document adding patent(s), mail this copy to Director Copy 4—Case file copy

TO: Mail Stop 8 Director of the U.S. Patent & Trademark Office P.O. Box 1450 Alexandria, VA 22313-1450	REPORT ON THE FILING OR DETERMINATION OF AN ACTION REGARDING A PATENT OR TRADEMARK
---	---

In Compliance with 35 § 290 and/or 15 U.S.C. § 1116 you are hereby advised that a court action has been filed in the U.S. District Court Northern District of California on the following Patents or Trademarks:

DOCKET NO. CV 08-05687 HRL	DATE FILED 12/19/2008	U.S. DISTRICT COURT 280 North First St, Rm 2112, San Jose, CA 95121
PLAINTIFF SYMANTEC CORPORATION		DEFENDANT CROSSROADS SYSTEMS INC.
PATENT OR TRADEMARK NO.	DATE OF PATENT OR TRADEMARK	HOLDER OF PATENT OR TRADEMARK
1 <i>7 Exts pg. 2</i>		SEE ATTACHED COMPLAINT
2		
3		
4		
5		

In the above--entitled case, the following patent(s) have been included:

DATE INCLUDED	INCLUDED BY <input type="checkbox"/> Amendment <input type="checkbox"/> Answer <input type="checkbox"/> Cross Bill <input type="checkbox"/> Other Pleading	
PATENT OR TRADEMARK NO.	DATE OF PATENT OR TRADEMARK	HOLDER OF PATENT OR TRADEMARK
1		
2		
3		
4		
5		

In the above--entitled case, the following decision has been rendered or judgement issued:

DECISION/JUDGEMENT

CLERK Richard W. Wicking	(BY) DEPUTY CLERK Betty Walton	DATE December 19, 2008
-----------------------------	-----------------------------------	---------------------------

Copy 1—Upon initiation of action, mail this copy to Commissioner Copy 3—Upon termination of action, mail this copy to Commissioner
 Copy 2—Upon filing document adding patent(s), mail this copy to Commissioner Copy 4—Case file copy

1 LATHAM & WATKINS LLP
Mark A. Fligel (Bar No. 110635)
2 Yury Kapgan (Bar No. 218366)
355 South Grand Avenue
3 Los Angeles, California 90071-1560
Telephone: (213) 485-1234
4 Facsimile: (213) 891-8763

ORIGINAL
FILED

08 DEC 19 PM 5:00

RICHARD W. WIEKING
CLERK
U.S. DISTRICT COURT
NO. DIST. OF CA S.J.

5 LATHAM & WATKINS LLP
6 David A. Nelson, *pro hac vice pending*
Jennifer Bauer, *pro hac vice pending* ADR
7 5800 Sears Tower
Chicago, IL 60606
8 Telephone: (312) 876-7700
Facsimile (312) 993-9767
9

E-filing

10 Attorneys for Plaintiff
Symantec Corporation
11

12 UNITED STATES DISTRICT COURT
13 NORTHERN DISTRICT OF CALIFORNIA
14 SAN JOSE DIVISION

15 SYMANTEC CORPORATION,
a Delaware Corporation,

16 Plaintiff,

17 v.

18 CROSSROADS SYSTEMS, INC.
a Texas Corporation

19 Defendant.
20

C08-05687 HRL
COMPLAINT FOR DECLARATORY
JUDGMENT

21 DEMAND FOR JURY TRIAL
22

23 COMPLAINT

24 Plaintiff Symantec Corporation ("Symantec") hereby pleads the following claims
25 for Declaratory Judgment against Defendant Crossroads Systems, Inc. ("Crossroads"), and
26 alleges as follows:
27
28

COPY

LATHAM & WATKINS
ATTORNEYS AT LAW
LOS ANGELES

COMPLAINT FOR
DECLARATORY JUDGMENT

FAXED

1 **PARTIES**

2 1. Plaintiff Symantec is a Delaware Corporation with its principal place of
3 business at 20330 Stevens Creek Boulevard, Cupertino, California 95014-2132.

4 2. On information and belief, Defendant Crossroads is a Texas Corporation with
5 its principal place of business at 11000 MoPac Expressway, Austin, Texas, 78759.

6 **JURISDICTION AND VENUE**

7 3. The Court has subject matter jurisdiction over this action and the matter
8 pleaded herein under 28 U.S.C. §§ 1331 and 1338(a) because the action arises under the Federal
9 Declaratory Judgment Act, 28 U.S.C. § 2201 *et seq.*, and the Patent Act of the United States, 35
10 U.S.C. § 1, *et seq.*

11 4. Venue is proper in the United States District Court for the Northern District
12 of California pursuant to 28 U.S.C. § 1391(b)(2) in that a substantial part of the acts giving rise
13 to the claim occurred in this District, and Crossroads is subject to personal jurisdiction in this
14 District.

15 **INTRADISTRICT ASSIGNMENT**

16 5. This action for a declaratory judgment of non-infringement and invalidity of
17 patents is assigned on a district-wide basis under Civil L.R. 3-2(c).

18 **GENERAL ALLEGATIONS**

19 6. This action involves U.S. Patent No. 5,941,972 ("the '972 patent") attached
20 hereto as Exhibit A, U.S. Patent No. 6,425,035 ("the '035 patent"), attached hereto as Exhibit B,
21 U.S. Patent No. 6,421,753 ("the '753 patent"), attached hereto as Exhibit C, U.S. Patent No.
22 6,763,419 ("the '419 patent"), attached hereto as Exhibit D, U.S. Patent No. 6,738,854 ("the '854
23 patent"), attached hereto as Exhibit E, U.S. Patent No. 6,789,152 ("the '152 patent"), attached
24 hereto as Exhibit F, and U.S. Patent No. 7,051,147 ("the '147 patent"), attached hereto as Exhibit
25 G (collectively "the patents-in-suit"). The '035, '753, '419, '854, '152 and '147 patents all claim
26 priority to the '972 patent.

27 7. On August 26, 2004, Crossroads sent a letter to Veritas Software Corporation
28 ("Veritas") offering Veritas a license to the '972 and '035 patents in exchange, in part, for "a

1 14. Pursuant to the Federal Declaratory Judgment Act, 28 U.S.C. § 2201 *et seq.*,
2 Symantec requests the declaration of the Court that Symantec does not infringe and has not
3 infringed any claim of the patents-in-suit.

4 **SECOND CLAIM FOR RELIEF**

5 **Declaratory Relief Regarding Invalidity**

6 15. Symantec incorporates herein the allegations of paragraphs 1-11.

7 16. An actual and justiciable controversy exists between Plaintiff Symantec and
8 Defendant Crossroads as to the invalidity of the patents-in-suit, which is evidenced by
9 Crossroads' allegations that Veritas' products, later acquired by Symantec, as well as other
10 Symantec products infringe valid claims of the patents-in-suit, and Symantec's allegations
11 herein.

12 17. Pursuant to the Federal Declaratory Judgment Act, 28 U.S.C. § 2201 *et seq.*,
13 Symantec requests the declaration of the Court that the patents-in-suit are invalid under the
14 Patent Act, 35 U.S.C. §§ 41 *et seq.*, including but not limited to sections 102, 103, and 112.

15 **PRAYER FOR RELIEF**

16 WHEREFORE, Plaintiff Symantec respectfully requests that the Court enter
17 declaratory judgment as follows:

18 1. That Symantec does not infringe and has not infringed, directly or indirectly,
19 any of the patents-in-suit;

20 2. That the patents-in-suit are invalid;

21 3. That Crossroads, and all persons acting on its behalf or in concert with it, be
22 permanently enjoined and restrained from charging, orally or in writing, that any of the patents-
23 in-suit is infringed by Symantec, directly or indirectly;

24 4. That Symantec be awarded its costs, expenses and reasonable attorney fees in
25 this action; and

26 5. That Symantec be awarded such other and further relief as the Court may deem
27 appropriate.

28

DEMAND FOR JURY TRIAL

Plaintiff Symantec respectfully demands a jury trial in this action.

Dated: December 19, 2008

LATHAM & WATKINS LLP

By Mark A. Flagel
Mark A. Flagel
Attorneys for Plaintiff
SYMANTEC CORPORATION

1
2
3
4
5
6
7
8
9
10
11
12
13
14
15
16
17
18
19
20
21
22
23
24
25
26
27
28

IN THE UNITED STATES PATENT AND TRADEMARK OFFICE	
NOTIFICATION OF LARGE ENTITY STATUS	Atty. Docket No. CROSS1120-13
Applicant: Geoffrey B. Hoese, et al.	
Application No. 10/658,163	Filing Date: 09/09/2003
Patent No. 7,051,147	Issue Date 05/23/2006
For: Storage Router and Method for Providing Virtual Local Storage	
Group Art: 2182	Confirmation No. 5675

Commissioner for Patents
P.O. Box 1450
Alexandria, VA 22313

Dear Sir:

<u>Certificate of Transmission Under 37 C.F.R. § 1.8</u>
I hereby certify that this correspondence is being deposited electronically with the U.S. Patent and Trademark Office using the United States Patent and Trademark Office's EFS-Web system on June <u>9</u> , 2008.
 Janice Pampell

On review of the file for this matter, it appears that all the proper fees have been paid. While this notification may be redundant, we hereby submit this notification that the assignee of the above-referenced patent is a large entity.

While Applicant does not believe any further fees are due and owing, the Commissioner is hereby authorized to charge any fees or credit any overpayments to Deposit Account No. 50-3183 of Sprinkle IP Law Group.

Respectfully submitted,

Sprinkle IP Law Group

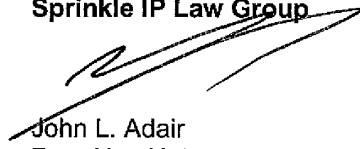

John L. Adair
Reg. No. 48,828

Dated: June 6, 2008

1301 W. 25th Street
Suite 408
Austin, TX 78705
Tel. 512-637-9220
Fax. 512-371-9088

Electronic Acknowledgement Receipt

EFS ID:	3421245
Application Number:	10658163
International Application Number:	
Confirmation Number:	5675
Title of Invention:	STORAGE ROUTER AND METHOD FOR PROVIDING VIRTUAL LOCAL STORAGE
First Named Inventor/Applicant Name:	Geoffrey B. Hoese
Customer Number:	44654
Filer:	John L. Adair/Janice Pampell
Filer Authorized By:	John L. Adair
Attorney Docket Number:	CROSS1120-13
Receipt Date:	09-JUN-2008
Filing Date:	09-SEP-2003
Time Stamp:	09:58:02
Application Type:	Utility under 35 USC 111(a)

Payment information:

Submitted with Payment	no
------------------------	----

File Listing:

Document Number	Document Description	File Name	File Size(Bytes) /Message Digest	Multi Part /.zip	Pages (if appl.)
1	Miscellaneous Incoming Letter	CROWSS1120-13_Notification_of_Large_Entity_Status.pdf	26724 <small>019e69ee3825db37438f835876a6f39f03a3ce97</small>	no	1

Warnings:

Information:

Total Files Size (in bytes):

26724

This Acknowledgement Receipt evidences receipt on the noted date by the USPTO of the indicated documents, characterized by the applicant, and including page counts, where applicable. It serves as evidence of receipt similar to a Post Card, as described in MPEP 503.

New Applications Under 35 U.S.C. 111

If a new application is being filed and the application includes the necessary components for a filing date (see 37 CFR 1.53(b)-(d) and MPEP 506), a Filing Receipt (37 CFR 1.54) will be issued in due course and the date shown on this Acknowledgement Receipt will establish the filing date of the application.

National Stage of an International Application under 35 U.S.C. 371

If a timely submission to enter the national stage of an international application is compliant with the conditions of 35 U.S.C. 371 and other applicable requirements a Form PCT/DO/EO/903 indicating acceptance of the application as a national stage submission under 35 U.S.C. 371 will be issued in addition to the Filing Receipt, in due course.

New International Application Filed with the USPTO as a Receiving Office

If a new international application is being filed and the international application includes the necessary components for an international filing date (see PCT Article 11 and MPEP 1810), a Notification of the International Application Number and of the International Filing Date (Form PCT/RO/105) will be issued in due course, subject to prescriptions concerning national security, and the date shown on this Acknowledgement Receipt will establish the international filing date of the application.

03-15-06

PART B - FEE(S) TRANSMITTAL

Complete and send this form, together with applicable fee(s), to: Mail Stop ISSUE FEE Commissioner for Patents P.O. Box 1450 Alexandria, Virginia 22313-1450 or Fax (571) 273-2885

INSTRUCTIONS: This form should be used for transmitting the ISSUE FEE and PUBLICATION FEE (if required). Blocks 1 through 5 should be completed where appropriate. All further correspondence including the Patent, advance orders and notification of maintenance fees will be mailed to the current correspondence address as indicated unless corrected below or directed otherwise in Block 1, by (a) specifying a new correspondence address; and/or (b) indicating a separate "FEE ADDRESS" for maintenance fee notifications.

CURRENT CORRESPONDENCE ADDRESS (Note: Use Block 1 for any change of address)

Note: A certificate of mailing can only be used for domestic mailings of the Fee(s) Transmittal. This certificate cannot be used for any other accompanying papers. Each additional paper, such as an assignment or formal drawing, must have its own certificate of mailing or transmission.

25094 7590 01/20/2006 DLA PIPER RUDNICK GRAY CARY US, LLP 2000 University Avenue E. Palo Alto, CA 94303-2248



Express Certificate of Mailing or Transmission hereby certify that this Fee(s) Transmittal is being deposited with the United States Postal Service with sufficient postage for first class mail in an envelope addressed to the Mail Stop ISSUE FEE address above, or being facsimile transmitted to the USPTO (571) 273-2885, on the date indicated below.

44654 Sprinkle IP Law Group 1301 W. 25th Street, Suite 408 Austin, Texas 78705

Stacy Sutton Kirby (Depositor's name) Stacy Sutton Kirby (Signature) March 14, 2006 (Date)

Table with 4 columns: APPLICATION NO., FILING DATE, FIRST NAMED INVENTOR, ATTORNEY DOCKET NO., CONFIRMATION NO. Values: 10/658,163, 09/09/2003, Geoffrey B. Hoesle, CROSS1120-13, 5675

TITLE OF INVENTION: STORAGE ROUTER AND METHOD FOR PROVIDING VIRTUAL LOCAL STORAGE

Table with 6 columns: APPLN. TYPE, SMALL ENTITY, ISSUE FEE, PUBLICATION FEE, TOTAL FEE(S) DUE, DATE DUE. Values: nonprovisional, YES, \$700, \$300, \$1000, 04/20/2006

Table with 3 columns: EXAMINER, ART UNIT, CLASS-SUBCLASS. Values: SHIN, CHRISTOPHER B, 2182, 710-001000

- 1. Change of correspondence address or indication of "Fee Address" (37 CFR 1.363). [X] Change of correspondence address (or Change of Correspondence Address form PTO/SB/122) attached. [] "Fee Address" indication (or "Fee Address" Indication form PTO/SB/47; Rev 03-02 or more recent) attached. Use of a Customer Number is required. 2. For printing on the patent front page, list (1) the names of up to 3 registered patent attorneys or agents OR, alternatively, (2) the name of a single firm (having as a member a registered attorney or agent) and the names of up to 2 registered patent attorneys or agents. If no name is listed, no name will be printed. 3. Sprinkle IP Law Group

3. ASSIGNEE NAME AND RESIDENCE DATA TO BE PRINTED ON THE PATENT (print or type) PLEASE NOTE: Unless an assignee is identified below, no assignee data will appear on the patent. If an assignee is identified below, the document has been filed for recordation as set forth in 37 CFR 3.11. Completion of this form is NOT a substitute for filing an assignment.

(A) NAME OF ASSIGNEE Crossroads Systems, Inc. (B) RESIDENCE: (CITY AND STATE OR COUNTRY) Austin, TX 78701

03/16/2006 BABRAHA2 00000046 10658163 01 FC:1501 1400.00 DP 02 FC:1504 300.00 DP 03 FC:8001 3.00 DP

Please check the appropriate assignee category or categories (will not be printed on the patent): [] Individual [X] Corporation or other private group entity [] Government

- 4a. The following fee(s) are enclosed: [X] Issue Fee [] Publication Fee (No small entity discount permitted) [X] Advance Order - # of Copies 1 4b. Payment of Fee(s): [X] A check in the amount of the fee(s) is enclosed. [] Payment by credit card. Form PTO-2038 is attached. [X] The Director is hereby authorized by charge the registered fee(s), or credit any overpayment, to Deposit Account Number 50-3183 (enclose an extra copy of this form).

5. Change in Entity Status (from status indicated above) [] a. Applicant claims SMALL ENTITY status. See 37 CFR 1.27. [] b. Applicant is no longer claiming SMALL ENTITY status. See 37 CFR 1.27(g)(2).

The Director of the USPTO is requested to apply the Issue Fee and Publication Fee (if any) or to re-apply any previously paid issue fee to the application identified above. NOTE: The Issue Fee and Publication Fee (if required) will not be accepted from anyone other than the applicant; a registered attorney or agent; or the assignee or other party in interest as shown by the records of the United States Patent and Trademark Office.

Authorized Signature [Signature] Date 3/17/06 Typed or printed name JENN ADAIR Registration No. 48,828

This collection of information is required by 37 CFR 1.311. The information is required to obtain or retain a benefit by the public which is to file (and by the USPTO to process) an application. Confidentiality is governed by 35 U.S.C. 122 and 37 CFR 1.14. This collection is estimated to take 12 minutes to complete, including gathering, preparing, and submitting the completed application form to the USPTO. Time will vary depending upon the individual case. Any comments on the amount of time you require to complete this form and/or suggestions for reducing this burden, should be sent to the Chief Information Officer, U.S. Patent and Trademark Office, U.S. Department of Commerce, P.O. Box 1450, Alexandria, Virginia 22313-1450. DO NOT SEND FEES OR COMPLETED FORMS TO THIS ADDRESS. SEND TO: Commissioner for Patents, P.O. Box 1450, Alexandria, Virginia 22313-1450.

Under the Paperwork Reduction Act of 1995, no persons are required to respond to a collection of information unless it displays a valid OMB control number.

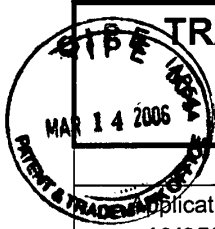

TRANSMITTAL OF PAYMENT OF ISSUE FEE (LARGE Entity) 37 C.F.R. 1.311				Docket No. CROSS1120-13
Applicant(s)				
Application No. 10/658,163	Filing Date 09/09/2003	Examiner Shin, Christopher B.	Group Art Unit 2182	Confirmation No. 5675
Title:				

**Mail Stop: Issue Fee
Commissioner for Patents
P.O. Box 1450
Alexandria, VA 22313-1450**

Transmitted herewith are the following items in reference to the above-identified application:

- Issue Fee Transmittal Form PTOL-85
- Issue Fee: \$1,400.00
- Publication Fee \$300.00
- Advanced Order - No. of Copies 1/ Fee \$3.00
- Letter to Official Draftsperson and Formal Drawings
- Postcard

- A check in the amount of \$1703.00 is attached
- The Director is hereby authorized to charge Deposit Account No. 50-3183 of Sprinkle IP Law Group the above-noted fee
- The Director is hereby authorized to charge any deficiencies or credit any overpayments to Deposit Account No. 50-3183 of Sprinkle IP Law Group.



John L. Adair
Reg. No. 48,828

Customer No. 44654
Sprinkle IP Law Group
1301 W. 25th Street, Suite 408
Austin, Texas 78705
Tel. (512) 637-9223
Fax. (512) 371-9088

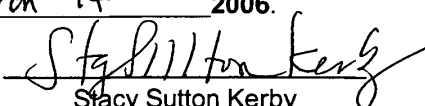
Certificate of Mailing Under 37 C.F.R. 1.10
I hereby certify that this document and fee is being deposited with the U.S. Postal Service as Express Mail No. EV828700999US in an envelope addressed to Mail Stop: Issue Fee, Commissioner for Patents, P.O. Box 1450, Alexandria, VA 22313 on <u>March 14</u> <u>2006</u> .
 Stacy Sutton Kerby



UNITED STATES PATENT AND TRADEMARK OFFICE

UNITED STATES DEPARTMENT OF COMMERCE
United States Patent and Trademark Office
Address: COMMISSIONER FOR PATENTS
P.O. Box 1450
Alexandria, Virginia 22313-1450
www.uspto.gov

APPLICATION NUMBER	FILING OR 371 (c) DATE	FIRST NAMED APPLICANT	ATTY. DOCKET NO./TITLE
10/658,163	09/09/2003	Geoffrey B. Hoese	CROSS1120-13

44654
SPRINKLE IP LAW GROUP
1301 W. 25TH STREET
SUITE 408
AUSTIN, TX 78705

CONFIRMATION NO. 5675

OC000000018039068

OC000000018039068



Date Mailed: 02/10/2006

NOTICE OF ACCEPTANCE OF POWER OF ATTORNEY

This is in response to the Power of Attorney filed 07/26/2005.

The Power of Attorney in this application is accepted. Correspondence in this application will be mailed to the above address as provided by 37 CFR 1.33.

RECEIVED BY: SP

FEB 21 2006

Docketed By: _____

Date Docketed: _____

Attorney: _____

C/M No: _____

 ALBERTINA L. JACKSON
 2100 (571) 272-3594

ATTORNEY/APPLICANT COPY

Issue Classification 	Application/Control No. 10/658,163	Applicant(s)/Patent under Reexamination HOESE ET AL.	
	Examiner Christopher B. Shin	Art Unit 2182	

ISSUE CLASSIFICATION										
ORIGINAL					CROSS REFERENCE(S)					
CLASS	SUBCLASS				CLASS	SUBCLASS (ONE SUBCLASS PER BLOCK)				
710	305				710	11				
INTERNATIONAL CLASSIFICATION					709	258				
G	0	6	F	13/00						
				/						
				/						
				/						
				/						

(Assistant Examiner) (Date)	CHRISTOPHER SHIN PRIMARY EXAMINER OF 2182	Total Claims Allowed: 25 39	
<i>J. Hall</i> (Legal Instruments Examiner) 1-10-06 (Date)		<i>[Signature]</i> (Primary Examiner) 1-4-06 (Date)	O.G. Print Claim(s) 1

<input checked="" type="checkbox"/> Claims renumbered in the same order as presented by applicant				<input type="checkbox"/> CPA				<input type="checkbox"/> T.D.				<input type="checkbox"/> R.1.47			
Final	Original	Final	Original	Final	Original	Final	Original	Final	Original	Final	Original	Final	Original		
	1		31		61		91		121		151		181		
	2		32		62		92		122		152		182		
	3		33		63		93		123		153		183		
	4		34		64		94		124		154		184		
	5		35		65		95		125		155		185		
	6		36		66		96		126		156		186		
	7		37		67		97		127		157		187		
	8		38		68		98		128		158		188		
	9		39		69		99		129		159		189		
	10		40		70		100		130		160		190		
	11		41		71		101		131		161		191		
	12		42		72		102		132		162		192		
	13		43		73		103		133		163		193		
	14		44		74		104		134		164		194		
	15		45		75		105		135		165		195		
	16		46		76		106		136		166		196		
	17		47		77		107		137		167		197		
	18		48		78		108		138		168		198		
	19		49		79		109		139		169		199		
	20		50		80		110		140		170		200		
	21		51		81		111		141		171		201		
	22		52		82		112		142		172		202		
	23		53		83		113		143		173		203		
	24		54		84		114		144		174		204		
	25		55		85		115		145		175		205		
	26		56		86		116		146		176		206		
	27		57		87		117		147		177		207		
	28		58		88		118		148		178		208		
	29		59		89		119		149		179		209		
	30		60		90		120		150		180		210		



UNITED STATES PATENT AND TRADEMARK OFFICE

UNITED STATES DEPARTMENT OF COMMERCE
United States Patent and Trademark Office
Address: COMMISSIONER FOR PATENTS
P.O. Box 1450
Alexandria, Virginia 22313-1450
www.uspto.gov

APPLICATION NUMBER	FILING OR 371 (c) DATE	FIRST NAMED APPLICANT	ATTY. DOCKET NO./TITLE
10/658,163	09/09/2003	Geoffrey B. Hoese	CROSS1120-13

44654
SPRINKLE IP LAW GROUP
1301 W. 25TH STREET
SUITE 408
AUSTIN, TX 78705

CONFIRMATION NO. 5675
OC000000018039068
OC000000018039068

Date Mailed: 02/10/2006

NOTICE OF ACCEPTANCE OF POWER OF ATTORNEY

This is in response to the Power of Attorney filed 07/26/2005.

The Power of Attorney in this application is accepted. Correspondence in this application will be mailed to the above address as provided by 37 CFR 1.33.

ALBERTHA L JACKSON
2100 (571) 272-3594

OFFICE COPY



UNITED STATES PATENT AND TRADEMARK OFFICE

UNITED STATES DEPARTMENT OF COMMERCE
United States Patent and Trademark Office
Address: COMMISSIONER FOR PATENTS
P.O. Box 1450
Alexandria, Virginia 22313-1450
www.uspto.gov

APPLICATION NUMBER	FILING OR 371 (c) DATE	FIRST NAMED APPLICANT	ATTY. DOCKET NO./TITLE
10/658,163	09/09/2003	Geoffrey B. Hoese	CROSS1120-13

25094
DLA PIPER RUDNICK GRAY CARY US, LLP
2000 University Avenue
E. Palo Alto, CA 94303-2248

CONFIRMATION NO. 5675
OC000000018039055
OC000000018039055

Date Mailed: 02/10/2006

NOTICE REGARDING CHANGE OF POWER OF ATTORNEY

This is in response to the Power of Attorney filed 07/26/2005.

- The Power of Attorney to you in this application has been revoked by the assignee who has intervened as provided by 37 CFR 3.71. Future correspondence will be mailed to the new address of record(37 CFR 1.33).



 ALBERYTHA L JACKSON
 2100 (571) 272-3594

OFFICE COPY



UNITED STATES PATENT AND TRADEMARK OFFICE

UNITED STATES DEPARTMENT OF COMMERCE
United States Patent and Trademark Office
Address: COMMISSIONER FOR PATENTS
P.O. Box 1450
Alexandria, Virginia 22313-1450
www.uspto.gov

NOTICE OF ALLOWANCE AND FEE(S) DUE

25094 7590 01/20/2006
DLA PIPER RUDNICK GRAY CARY US, LLP
2000 University Avenue
E. Palo Alto, CA 94303-2248

EXAMINER
SHIN, CHRISTOPHER B

ART UNIT PAPER NUMBER
2182

DATE MAILED: 01/20/2006

Table with 5 columns: APPLICATION NO., FILING DATE, FIRST NAMED INVENTOR, ATTORNEY DOCKET NO., CONFIRMATION NO.
10/658,163 09/09/2003 Geoffrey B. Hoese CROSS1120-13 5675

TITLE OF INVENTION: STORAGE ROUTER AND METHOD FOR PROVIDING VIRTUAL LOCAL STORAGE

Table with 6 columns: APPLN. TYPE, SMALL ENTITY, ISSUE FEE, PUBLICATION FEE, TOTAL FEE(S) DUE, DATE DUE
nonprovisional YES \$700 \$300 \$1000 04/20/2006

THE APPLICATION IDENTIFIED ABOVE HAS BEEN EXAMINED AND IS ALLOWED FOR ISSUANCE AS A PATENT. PROSECUTION ON THE MERITS IS CLOSED. THIS NOTICE OF ALLOWANCE IS NOT A GRANT OF PATENT RIGHTS. THIS APPLICATION IS SUBJECT TO WITHDRAWAL FROM ISSUE AT THE INITIATIVE OF THE OFFICE OR UPON PETITION BY THE APPLICANT. SEE 37 CFR 1.313 AND MPEP 1308.

THE ISSUE FEE AND PUBLICATION FEE (IF REQUIRED) MUST BE PAID WITHIN THREE MONTHS FROM THE MAILING DATE OF THIS NOTICE OR THIS APPLICATION SHALL BE REGARDED AS ABANDONED. THIS STATUTORY PERIOD CANNOT BE EXTENDED. SEE 35 U.S.C. 151. THE ISSUE FEE DUE INDICATED ABOVE REFLECTS A CREDIT FOR ANY PREVIOUSLY PAID ISSUE FEE APPLIED IN THIS APPLICATION. THE PTOL-85B (OR AN EQUIVALENT) MUST BE RETURNED WITHIN THIS PERIOD EVEN IF NO FEE IS DUE OR THE APPLICATION WILL BE REGARDED AS ABANDONED.

HOW TO REPLY TO THIS NOTICE:

I. Review the SMALL ENTITY status shown above.

If the SMALL ENTITY is shown as YES, verify your current SMALL ENTITY status:

- A. If the status is the same, pay the TOTAL FEE(S) DUE shown above.
B. If the status above is to be removed, check box 5b on Part B - Fee(s) Transmittal and pay the PUBLICATION FEE (if required) and twice the amount of the ISSUE FEE shown above, or

If the SMALL ENTITY is shown as NO:

- A. Pay TOTAL FEE(S) DUE shown above, or
B. If applicant claimed SMALL ENTITY status before, or is now claiming SMALL ENTITY status, check box 5a on Part B - Fee(s) Transmittal and pay the PUBLICATION FEE (if required) and 1/2 the ISSUE FEE shown above.

II. PART B - FEE(S) TRANSMITTAL should be completed and returned to the United States Patent and Trademark Office (USPTO) with your ISSUE FEE and PUBLICATION FEE (if required). Even if the fee(s) have already been paid, Part B - Fee(s) Transmittal should be completed and returned. If you are charging the fee(s) to your deposit account, section "4b" of Part B - Fee(s) Transmittal should be completed and an extra copy of the form should be submitted.

III. All communications regarding this application must give the application number. Please direct all communications prior to issuance to Mail Stop ISSUE FEE unless advised to the contrary.

IMPORTANT REMINDER: Utility patents issuing on applications filed on or after Dec. 12, 1980 may require payment of maintenance fees. It is patentee's responsibility to ensure timely payment of maintenance fees when due.

PART B - FEE(S) TRANSMITTAL

Complete and send this form, together with applicable fee(s), to: Mail

Mail Stop ISSUE FEE
Commissioner for Patents
P.O. Box 1450
Alexandria, Virginia 22313-1450
 or Fax **(571) 273-2885**

INSTRUCTIONS: This form should be used for transmitting the ISSUE FEE and PUBLICATION FEE (if required). Blocks 1 through 5 should be completed where appropriate. All further correspondence including the Patent, advance orders and notification of maintenance fees will be mailed to the current correspondence address as indicated unless corrected below or directed otherwise in Block 1, by (a) specifying a new correspondence address; and/or (b) indicating a separate "FEE ADDRESS" for maintenance fee notifications.

CURRENT CORRESPONDENCE ADDRESS (Note: Use Block 1 for any change of address)

25094 7590 01/20/2006

DLA PIPER RUDNICK GRAY CARY US, LLP
 2000 University Avenue
 E. Palo Alto, CA 94303-2248

Note: A certificate of mailing can only be used for domestic mailings of the Fee(s) Transmittal. This certificate cannot be used for any other accompanying papers. Each additional paper, such as an assignment or formal drawing, must have its own certificate of mailing or transmission.

Certificate of Mailing or Transmission

I hereby certify that this Fee(s) Transmittal is being deposited with the United States Postal Service with sufficient postage for first class mail in an envelope addressed to the Mail Stop ISSUE FEE address above, or being facsimile transmitted to the USPTO (571) 273-2885, on the date indicated below.

_____ (Depositor's name)
_____ (Signature)
_____ (Date)

APPLICATION NO.	FILING DATE	FIRST NAMED INVENTOR	ATTORNEY DOCKET NO.	CONFIRMATION NO.
10/658,163	09/09/2003	Geoffrey B. Hoese	CROSS1120-13	5675

TITLE OF INVENTION: STORAGE ROUTER AND METHOD FOR PROVIDING VIRTUAL LOCAL STORAGE

APPLN. TYPE	SMALL ENTITY	ISSUE FEE	PUBLICATION FEE	TOTAL FEE(S) DUE	DATE DUE
nonprovisional	YES	\$700	\$300	\$1000	04/20/2006

EXAMINER	ART UNIT	CLASS-SUBCLASS
SHIN, CHRISTOPHER B	2182	710-001000

<p>1. Change of correspondence address or indication of "Fee Address" (37 CFR 1.363).</p> <p><input type="checkbox"/> Change of correspondence address (or Change of Correspondence Address form PTO/SB/122) attached.</p> <p><input type="checkbox"/> "Fee Address" indication (or "Fee Address" Indication form PTO/SB/47; Rev 03-02 or more recent) attached. Use of a Customer Number is required.</p>	<p>2. For printing on the patent front page, list</p> <p>(1) the names of up to 3 registered patent attorneys or agents OR, alternatively, _____ 1</p> <p>(2) the name of a single firm (having as a member a registered attorney or agent) and the names of up to 2 registered patent attorneys or agents. If no name is listed, no name will be printed. _____ 2</p> <p>_____ 3</p>
--	---

3. ASSIGNEE NAME AND RESIDENCE DATA TO BE PRINTED ON THE PATENT (print or type)

PLEASE NOTE: Unless an assignee is identified below, no assignee data will appear on the patent. If an assignee is identified below, the document has been filed for recordation as set forth in 37 CFR 3.11. Completion of this form is NOT a substitute for filing an assignment.

(A) NAME OF ASSIGNEE _____ (B) RESIDENCE: (CITY and STATE OR COUNTRY) _____

Please check the appropriate assignee category or categories (will not be printed on the patent): Individual Corporation or other private group entity Government

<p>4a. The following fee(s) are enclosed:</p> <p><input type="checkbox"/> Issue Fee</p> <p><input type="checkbox"/> Publication Fee (No small entity discount permitted)</p> <p><input type="checkbox"/> Advance Order - # of Copies _____</p>	<p>4b. Payment of Fee(s):</p> <p><input type="checkbox"/> A check in the amount of the fee(s) is enclosed.</p> <p><input type="checkbox"/> Payment by credit card. Form PTO-2038 is attached.</p> <p><input type="checkbox"/> The Director is hereby authorized by charge the required fee(s), or credit any overpayment, to Deposit Account Number _____ (enclose an extra copy of this form).</p>
--	---

5. Change in Entity Status (from status indicated above)

a. Applicant claims SMALL ENTITY status. See 37 CFR 1.27. b. Applicant is no longer claiming SMALL ENTITY status. See 37 CFR 1.27(g)(2).

The Director of the USPTO is requested to apply the Issue Fee and Publication Fee (if any) or to re-apply any previously paid issue fee to the application identified above. NOTE: The Issue Fee and Publication Fee (if required) will not be accepted from anyone other than the applicant; a registered attorney or agent; or the assignee or other party in interest as shown by the records of the United States Patent and Trademark Office.

Authorized Signature _____ Date _____

Typed or printed name _____ Registration No. _____

This collection of information is required by 37 CFR 1.311. The information is required to obtain or retain a benefit by the public which is to file (and by the USPTO to process) an application. Confidentiality is governed by 35 U.S.C. 122 and 37 CFR 1.14. This collection is estimated to take 12 minutes to complete, including gathering, preparing, and submitting the completed application form to the USPTO. Time will vary depending upon the individual case. Any comments on the amount of time you require to complete this form and/or suggestions for reducing this burden, should be sent to the Chief Information Officer, U.S. Patent and Trademark Office, U.S. Department of Commerce, P.O. Box 1450, Alexandria, Virginia 22313-1450. DO NOT SEND FEES OR COMPLETED FORMS TO THIS ADDRESS. SEND TO: Commissioner for Patents, P.O. Box 1450, Alexandria, Virginia 22313-1450.

Under the Paperwork Reduction Act of 1995, no persons are required to respond to a collection of information unless it displays a valid OMB control number.



UNITED STATES PATENT AND TRADEMARK OFFICE

UNITED STATES DEPARTMENT OF COMMERCE
United States Patent and Trademark Office
Address: COMMISSIONER FOR PATENTS
P.O. Box 1450
Alexandria, Virginia 22313-1450
www.uspto.gov

Table with 5 columns: APPLICATION NO., FILING DATE, FIRST NAMED INVENTOR, ATTORNEY DOCKET NO., CONFIRMATION NO.
Row 1: 10/658,163, 09/09/2003, Geoffrey B. Hoese, CROSS1120-13, 5675
Row 2: 25094, 7590, 01/20/2006, [EXAMINER SHIN, CHRISTOPHER B], [ART UNIT 2182, PAPER NUMBER]

DLA PIPER RUDNICK GRAY CARY US, LLP
2000 University Avenue
E. Palo Alto, CA 94303-2248

DATE MAILED: 01/20/2006

Determination of Patent Term Adjustment under 35 U.S.C. 154 (b)
(application filed on or after May 29, 2000)

The Patent Term Adjustment to date is 0 day(s). If the issue fee is paid on the date that is three months after the mailing date of this notice and the patent issues on the Tuesday before the date that is 28 weeks (six and a half months) after the mailing date of this notice, the Patent Term Adjustment will be 0 day(s).

If a Continued Prosecution Application (CPA) was filed in the above-identified application, the filing date that determines Patent Term Adjustment is the filing date of the most recent CPA.

Applicant will be able to obtain more detailed information by accessing the Patent Application Information Retrieval (PAIR) WEB site (http://pair.uspto.gov).

Any questions regarding the Patent Term Extension or Adjustment determination should be directed to the Office of Patent Legal Administration at (571) 272-7702. Questions relating to issue and publication fee payments should be directed to the Customer Service Center of the Office of Patent Publication at (703) 305-8283.

Notice of Allowability	Application No.	Applicant(s)	
	10/658,163	HOESE ET AL.	
	Examiner	Art Unit	
	Christopher B. Shin	2182	

-- The MAILING DATE of this communication appears on the cover sheet with the correspondence address--

All claims being allowable, PROSECUTION ON THE MERITS IS (OR REMAINS) CLOSED in this application. If not included herewith (or previously mailed), a Notice of Allowance (PTOL-85) or other appropriate communication will be mailed in due course. **THIS NOTICE OF ALLOWABILITY IS NOT A GRANT OF PATENT RIGHTS.** This application is subject to withdrawal from issue at the initiative of the Office or upon petition by the applicant. See 37 CFR 1.313 and MPEP 1308.

1. This communication is responsive to the AF received December 20, 2005.
2. The allowed claim(s) is/are 15-53.
3. Acknowledgment is made of a claim for foreign priority under 35 U.S.C. § 119(a)-(d) or (f).
 - a) All b) Some* c) None of the:
 1. Certified copies of the priority documents have been received.
 2. Certified copies of the priority documents have been received in Application No. _____.
 3. Copies of the certified copies of the priority documents have been received in this national stage application from the International Bureau (PCT Rule 17.2(a)).

* Certified copies not received: _____.

Applicant has THREE MONTHS FROM THE "MAILING DATE" of this communication to file a reply complying with the requirements noted below. Failure to timely comply will result in ABANDONMENT of this application. **THIS THREE-MONTH PERIOD IS NOT EXTENDABLE.**

4. A SUBSTITUTE OATH OR DECLARATION must be submitted. Note the attached EXAMINER'S AMENDMENT or NOTICE OF INFORMAL PATENT APPLICATION (PTO-152) which gives reason(s) why the oath or declaration is deficient.
 5. CORRECTED DRAWINGS (as "replacement sheets") must be submitted.
 - (a) including changes required by the Notice of Draftsperson's Patent Drawing Review (PTO-948) attached
 - 1) hereto or 2) to Paper No./Mail Date _____.
 - (b) including changes required by the attached Examiner's Amendment / Comment or in the Office action of Paper No./Mail Date _____.
- Identifying Indicia such as the application number (see 37 CFR 1.84(c)) should be written on the drawings in the front (not the back) of each sheet. Replacement sheet(s) should be labeled as such in the header according to 37 CFR 1.121(d).**
6. DEPOSIT OF and/or INFORMATION about the deposit of BIOLOGICAL MATERIAL must be submitted. Note the attached Examiner's comment regarding REQUIREMENT FOR THE DEPOSIT OF BIOLOGICAL MATERIAL.

Attachment(s)

- | | |
|---|--|
| 1. <input type="checkbox"/> Notice of References Cited (PTO-892) | 5. <input type="checkbox"/> Notice of Informal Patent Application (PTO-152) |
| 2. <input type="checkbox"/> Notice of Draftsperson's Patent Drawing Review (PTO-948) | 6. <input type="checkbox"/> Interview Summary (PTO-413),
Paper No./Mail Date _____. |
| 3. <input type="checkbox"/> Information Disclosure Statements (PTO-1449 or PTO/SB/08),
Paper No./Mail Date _____ | 7. <input type="checkbox"/> Examiner's Amendment/Comment |
| 4. <input type="checkbox"/> Examiner's Comment Regarding Requirement for Deposit
of Biological Material | 8. <input type="checkbox"/> Examiner's Statement of Reasons for Allowance |
| | 9. <input type="checkbox"/> Other _____. |

**CHRISTOPHER B. SHIN
PRIMARY EXAMINER
GROUP 2182**



AFB
JPW

IN THE UNITED STATES PATENT AND TRADEMARK OFFICE

REPLY TO OFFICE ACTION DATED 11/01/2005 Atty. Docket No. CROSS1120-13



Applicant Geoffrey B. Hoese	
Application Number 10/658,163	Date Filed 09/09/2003
Title Storage Router and Method for Providing Virtual Local Storage	
Group Art Unit 2182	Examiner Shin, Christopher B.
Confirmation Number: 5675	

Commissioner for Patents
P.O. Box 1450
Alexandria, VA 22313-1450

Dear Sir:

Certificate of Mailing Under 37 C.F.R. §1.8

I hereby certify that this correspondence is being deposited with the United States Postal Service as First Class Mail in an envelope addressed to Commissioner for Patents, P.O. Box 1450, Alexandria, VA 22312-1450 on 12-15-05.

Julie H. Blackard
Signature



JULIE H. BLACKARD
Printed Name

In response to the Official Action mailed November 1, 2005, Applicant respectfully requests the Examiner reconsider the rejections of the Claims in view of this reply.

OK
to
Anton
1-4-08

Issue Classification 	Application/Control No. 10/658,163	Applicant(s)/Patent under Reexamination HOESE ET AL.	
	Examiner Christopher B. Shin	Art Unit 2182	

ISSUE CLASSIFICATION										
ORIGINAL					CROSS REFERENCE(S)					
CLASS		SUBCLASS			CLASS	SUBCLASS (ONE SUBCLASS PER BLOCK)				
710		305			710	11				
INTERNATIONAL CLASSIFICATION					709	258				
G	0	6	F	13/00						
				/						
				/						
				/						
				/						

_____ (Assistant Examiner) (Date)		CHRISTOPHER SHIN PRIMARY EXAMINER OF 2182		Total Claims Allowed: 21	
 (Legal Instruments Examiner)		 (Primary Examiner)		O.G. Print Claim(s) 1	O.G. Print Fig. 3
1-10-06 (Date)		1-4-06 (Date)			

<input checked="" type="checkbox"/> Claims renumbered in the same order as presented by applicant				<input type="checkbox"/> CPA				<input type="checkbox"/> T.D.				<input type="checkbox"/> R.1.47			
Final	Original	Final	Original	Final	Original	Final	Original	Final	Original	Final	Original	Final	Original		
	1		31		61		91		121		151		181		
	2		32		62		92		122		152		182		
	3		33		63		93		123		153		183		
	4		34		64		94		124		154		184		
	5		35		65		95		125		155		185		
	6		36		66		96		126		156		186		
	7		37		67		97		127		157		187		
	8		38		68		98		128		158		188		
	9		39		69		99		129		159		189		
	10		40		70		100		130		160		190		
	11		41		71		101		131		161		191		
	12		42		72		102		132		162		192		
	13		43		73		103		133		163		193		
	14		44		74		104		134		164		194		
	15		45		75		105		135		165		195		
	16		46		76		106		136		166		196		
	17		47		77		107		137		167		197		
	18		48		78		108		138		168		198		
	19		49		79		109		139		169		199		
	20		50		80		110		140		170		200		
	21		51		81		111		141		171		201		
	22		52		82		112		142		172		202		
	23		53		83		113		143		173		203		
	24		54		84		114		144		174		204		
	25		55		85		115		145		175		205		
	26		56		86		116		146		176		206		
	27		57		87		117		147		177		207		
	28		58		88		118		148		178		208		
	29		59		89		119		149		179		209		
	30		60		90		120		150		180		210		

Search Notes



Application/Control No.

10/658,163

Examiner

Christopher B. Shin

Applicant(s)/Patent under Reexamination

HOESE ET AL.

Art Unit

2182

SEARCHED

Class	Subclass	Date	Examiner
710	1-5	10/24/2005	CBS
710	8-13	10/24/2005	CBS
710	22-28	10/24/2005	CBS
710	305-306	10/24/2005	CBS
710	250	10/24/2005	CBS
709	258	10/24/2005	CBS
714	42	10/24/2005	CBS
711	112,113	10/24/2005	CBS
711	110	10/24/2005	CBS
710	126-131	10/24/2005	CBS
710	36-38	10/24/2005	CBS

INTERFERENCE SEARCHED

Class	Subclass	Date	Examiner
710	305, 11	1/3/2006	CBS
709	258	1/3/2006	CBS

**SEARCH NOTES
(INCLUDING SEARCH STRATEGY)**

	DATE	EXMR
PLUS	1/12/2005	CBS
PALM - for double patenting	1/13/2005	CBS
EAST (USPAT, EPO, JPO, DERWENT, IBMTDB)	1/15/2005	CBS
PALM - for double patenting	10/24/2005	CBS
PARENT & RELATED CASES WERE REVIEWED FOR THE ALLOWANCE	10/24/2005	CBS
CHECKED WITH EXR CHAN ALLEN FOR ALL OF THE RELATED RE-EXAM CASES FOR THE ALLOWANCE	10/24/2005	CBS

AT&T
DPW

IN THE UNITED STATES PATENT AND TRADEMARK OFFICE	
REPLY TO OFFICE ACTION DATED 11/01/2005	Atty. Docket No. CROSS1120-13
Applicant Geoffrey B. Hoese	
Application Number 10/658,163	Date Filed 09/09/2003
Title Storage Router and Method for Providing Virtual Local Storage	
Group Art Unit 2182	Examiner Shin, Christopher B.
Confirmation Number: 5675	



Commissioner for Patents
P.O. Box 1450
Alexandria, VA 22313-1450

Dear Sir:

<u>Certificate of Mailing Under 37 C.F.R. §1.8</u>
I hereby certify that this correspondence is being deposited with the United States Postal Service as First Class Mail in an envelope addressed to Commissioner for Patents, P.O. Box 1450, Alexandria, VA 22312-1450 on <u>12-15-05</u> .
 Signature
<u>JULIE H. BLACKARD</u> Printed Name

In response to the Official Action mailed November 1, 2005, Applicant respectfully requests the Examiner reconsider the rejections of the Claims in view of this reply.

IN THE CLAIMS:

Please amend the claims as follows. The claims are in the format as required by 35 C.F.R. § 1.121.

1-14 Cancelled

15. (Previously Presented) A storage router for providing virtual local storage on remote storage devices to a device, comprising:

a buffer providing memory work space for the storage router;

a first Fibre Channel controller operable to connect to and interface with a first Fibre Channel transport medium;

a second Fibre Channel controller operable to connect to and interface with a second Fibre Channel transport medium; and

a supervisor unit coupled to the first and second Fibre Channel controllers and the buffer, the supervisor unit operable:

to maintain a configuration for remote storage devices connected to the second Fibre Channel transport medium that maps between the device and the remote storage devices and that implements access controls for storage space on the remote storage devices; and

to process data in the buffer to interface between the first Fibre Channel controller and the second Fibre Channel controller to allow access from Fibre Channel initiator devices to the remote storage devices using native low level, block protocol in accordance with the configuration.

16. (Previously Presented) The storage router of claim 15, wherein the configuration maintained by the supervisor unit includes an allocation of subsets of storage space to associated Fibre Channel devices, wherein each subset is only accessible by the associated Fibre Channel device.

17. (Previously Presented) The storage router of claim 16, wherein the Fibre Channel devices comprise workstations.

18. (Previously Presented) The storage router of claim 16, wherein the remote storage devices comprise hard disk drives.

19. (Previously Presented) The storage router of claim 15, wherein each of the first Fibre Channel controller comprises:

- a Fibre Channel (FC) protocol unit operable to connect to the Fibre Channel transport medium;
- a first-in-first-out queue coupled to the Fibre Channel protocol unit; and
- a direct memory access (DMA) interface coupled to the first-in-first-out queue and to the buffer.

20. (Previously Presented) A storage network, comprising:

- a first Fibre Channel transport medium;
 - a second Fibre Channel transport medium;
 - a plurality of workstations connected to the first Fibre Channel transport medium;
 - a plurality of storage devices connected to the second Fibre Channel transport medium;
- and

a storage router interfacing between the first Fibre Channel transport medium and the second Fibre Channel transport medium, the storage router providing virtual local storage on the storage devices to the workstations and operable:

- to map between the workstations and the storage devices;
- to implement access controls for storage space on the storage devices; and
- to allow access from the workstations to the storage devices using native low level, block protocol in accordance with the mapping and access controls.

21. (Previously Presented) The storage network of claim 20, wherein the access controls include an allocation of subsets of storage space to associated workstations, wherein each subset is only accessible by the associated workstation.

22. (Previously Presented) The storage network of claim 20, wherein the storage devices comprise hard disk drives.

23. (Previously Presented) The storage network of claim 20, wherein the storage router comprises:

- a buffer providing memory work space for the storage router;
- a first Fibre Channel controller operable to connect to and interface with the first Fibre Channel transport medium, the first Fibre Channel controller further operable to pull outgoing

data from the buffer and to place incoming data into the buffer;

a second Fibre Channel controller operable to connect to and interface with the second Fibre Channel transport medium, the second Fibre Channel controller further operable to pull outgoing data from the buffer and to place incoming data into the buffer; and

a supervisor unit coupled to the first and second Fibre Channel controllers and the buffer, the supervisor unit operable:

to maintain a configuration for the storage devices that maps between workstations and storage devices and that implements the access controls for storage space on the storage devices; and

to process data in the buffer to interface between the first Fibre Channel controller and the second Fibre Channel controller to allow access from workstations to storage devices in accordance with the configuration.

24. (Previously Presented) A method for providing virtual local storage on remote storage devices to Fibre Channel devices, comprising:

interfacing with a first Fibre Channel transport medium;

interfacing with a second Fibre Channel transport medium;

maintaining a configuration for remote storage devices connected to the second Fibre Channel transport medium that maps between Fibre Channel devices and the remote storage devices and that implements access controls for storage space on the remote storage devices; and

allowing access from Fibre Channel initiator devices to the remote storage devices using native low level, block protocol in accordance with the configuration.

25. (Previously Presented) The method of claim 24, wherein maintaining the configuration includes allocating subsets of storage space to associated Fibre Channel devices, wherein each subset is only accessible by the associated Fibre Channel device.

26. (Previously Presented) The method of claim 25, wherein the Fibre Channel devices comprise workstations.

27. (Previously Presented) The method of claim 25, wherein the remote storage devices comprise hard disk drives.

28. (Previously Presented) An apparatus for providing virtual local storage on a remote storage device to a device operating according to a Fibre Channel protocol, comprising:
a first controller operable to connect to and interface with a first transport medium, wherein the first transport medium is operable according to the Fibre Channel protocol;
a second controller operable to connect to and interface with a second transport medium, wherein the second transport medium is operable according to the Fibre Channel protocol; and
a supervisor unit coupled to the first controller and the second controller, the supervisor unit operable to control access from the device connected to the first transport medium to the remote storage device connected to the second transport medium using native low level, block protocols according to a map between the device and the remote storage device.

29. (Previously Presented) The apparatus of Claim 28, wherein the supervisor unit is further operable to maintain a configuration wherein the configuration includes the map between the device and the remote storage device, and further wherein the map includes virtual LUNs that provide a representation of the storage device.

30. (Previously Presented) The apparatus of Claim 29, wherein the map only exposes the device to LUNs that the device may access.

31. (Previously Presented) The apparatus of Claim 28, wherein the supervisor unit is further operable to maintain a configuration including the map, wherein the map provides a mapping from a host device ID to a virtual LUN representation of the remote storage device to a physical LUN of the remote storage device.

32. (Previously Presented) The apparatus of Claim 28, wherein the remote storage device further comprises storage space partitioned into virtual local storage for the device connected to the first transport medium.

33. (Previously Presented) The apparatus of Claim 32, wherein the supervisor unit is further operable to prevent the device from accessing any storage on the remote storage device that is not part of a virtual local storage partition assigned to the device

34. (Previously Presented) The apparatus of Claim 28, wherein the first controller and the second controller further comprise a single controller.

35. (Previously Presented) A system for providing virtual local storage on remote storage devices, comprising:

 a first controller operable to connect to and interface with a first transport medium operable according to a Fibre Channel protocol;

 a second controller operable to connect to and interface with a second transport medium operable according to the Fibre Channel protocol;

 at least one device connected to the first transport medium;

 at least one storage device connected to the second transport medium; and

 an access control device coupled to the first controller and the second controller, the access control device operable to:

 map between the at least one device and a storage space on the at least one storage device; and

 control access from the at least one device to the at least one storage device using native low level, block protocol in accordance with the map.

36. (Previously Presented) The system of Claim 35, wherein the access control device is further operable to maintain a configuration wherein the configuration includes the map between the at least one device and the at least one storage device, and further wherein the map includes virtual LUNs that provide a representation of the at least one storage device.

37. (Previously Presented) The system of Claim 36, wherein the map only exposes the at least one device to LUNs that the at least one device may access.

38. (Previously Presented) The system of Claim 35, wherein the access control device is further operable to maintain a configuration including the map, wherein the map provides a mapping from a host device ID to a virtual LUN representation of the at least one storage device to a physical LUN of the at least one storage device.

39. (Previously Presented) The system of Claim 35, wherein the at least one storage device further comprises storage space partitioned into virtual local storage for the at least one device.

40. (Previously Presented) The system of Claim 39, wherein the access control unit is further operable to prevent at least one device from accessing any storage on the at least one storage device that is not part of a virtual local storage partition assigned to the at least one device.

41. (Previously Presented) The system of Claim 35, wherein the first controller and the second controller further comprise a single controller.

42. (Previously Presented) A method for providing virtual local storage on remote storage devices, comprising:

mapping between a device connected to a first transport medium and a storage device connected to a second transport medium, wherein the first transport medium and the second transport medium operate according to a Fibre Channel protocol;

implementing access controls for storage space on the storage device; and

allowing access from the device connected to the first transport medium to the storage device using native low level, block protocols.

43. (Previously Presented) The method of Claim 42, further comprising maintaining a configuration wherein the configuration includes a map between the device and the one storage device, and further wherein the map includes virtual LUNs that provide a representation of the storage device.

44. (Previously Presented) The method of Claim 43, wherein the map only exposes the device to LUNs that the device may access.

45. (Previously Presented) The method of Claim 42, further comprising maintaining a configuration including a map from a host device ID to a virtual LUN representation of the storage device to a physical LUN of the storage device.

46. (Previously Presented) The method of Claim 42, further comprising partitioning storage space on the storage device into virtual local storage for the device.

47. (Previously Presented) The method of Claim 46, further comprising preventing the device from accessing any storage on the storage device that is not part of a virtual local storage partition assigned to the device.

48. (Previously Presented) A system for providing virtual local storage, comprising:
a host device;
a storage device remote from the host device, wherein the storage device has a storage space;
a first controller;
a second controller
a first transport medium operable according to a Fibre Channel protocol, wherein the first transport medium connects the host device to the first controller;
a second transport medium operable according to the Fibre Channel protocol, wherein the second transport medium connects the second controller to the storage device;
a supervisor unit coupled to the first controller and the second controller, the supervisor unit operable to:
maintain a configuration that maps between the host device and at least a portion of the storage space on the storage device; and
implement access controls according to the configuration for the storage space on the storage device using native low level, block protocol.

49. (Previously Presented) The system of Claim 48, wherein the supervisor unit is further operable to:
maintain a configuration that maps from the host device to a virtual representation of at least a portion of the storage space on the storage device to the storage device; and
allow the host device to access only that portion of the storage space that is contained in the map.

50. (Previously Presented) The system of Claim 49, wherein the configuration comprises a map from a host device ID to a virtual LUN representation of the storage device to a physical LUN of the storage device.

51. (Previously Presented) The system of Claim 48, wherein the storage device further comprises storage space partitioned into virtual local storage for the host device.

52. (Previously Presented) The system of Claim 51, wherein the supervisor unit is further operable to prevent the host device from accessing any storage on the storage device that is not part of a virtual local storage partition assigned to the host device.

53. (Previously Presented) The apparatus of Claim 48, wherein the first controller and the second controller further comprise a single controller.

REMARKS

Applicant appreciates the time taken by the Examiner to review Applicant's present application. This application has been carefully reviewed in light of the Official Action mailed November 1, 2005. Applicant respectfully requests reconsideration and favorable action in this case.

Double Patenting Rejection

Applicant respectfully wishes to clarify that Applicant agreed that some aspects of the present invention are consistent with items addressed in issued applications and copending applications and reexaminations. Additionally Applicant agreed to submit a terminal disclaimer to obviate the Examiner's double patenting rejection. The submission of the terminal disclaimer is not an admission as to the propriety of the double patenting rejection. See, MPEP 804.02.

In the double patenting rejection, the Examiner listed the following related cases. To aid the Examiner, Applicant provides the following listing and status of each of the cases

09/001,799 issued as 5,941,972, under reexamination as 90/007,123 and 90/007,317

09/354,682 issued as 6,421,753, under reexamination as 90/007,124

09/081,110 issued as 6,789,152

10/081,114 now abandoned

10/023,786 now abandoned

09/965,335 issued as 6,425,035, under reexamination as 90/007,125

10/174,720 issued as 6,738,854, under reexamination as 90/007,127

09/965,339 issued as 6,425,036, under reexamination as 90/007,126

10/081,082 now abandoned

10/361,283 issued as 6,763,419

10/638,955 now abandoned

10/640,468 now abandoned

11/191,254 pending

Attorney Docket No.
CROSS1120-13

10/658,163
Customer ID: 44654

11

The Director of the U.S. Patent and Trademark Office is hereby authorized to charge any fees or credit any overpayments to Deposit Account No. 50-3183 of Sprinkle IP Law Group.

Respectfully submitted,

Sprinkle IP Law Group
Attorneys for Applicant

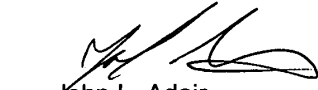

John L. Adair
Reg. No. 48,828

Date: 12/14/05

1301 W. 25th Street, Suite 408
Austin, TX 78705
Tel. (512) 637-9220
Fax. (512) 371-9088

IN THE UNITED STATES PATENT AND TRADEMARK OFFICE

TERMINAL DISCLAIMER TO OBVIATE A DOUBLE PATENTING REJECTION OVER A PRIOR PATENT

Atty. Docket No.
CROSS1120-13

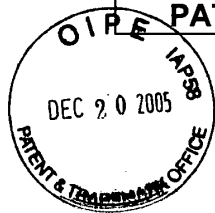

Applicant Geoffrey B. Hoese, et al.	
Application Number 10/658,163	Date Filed 09/09/2003
Title Storage Router and Method for Providing Virtual Local Storage	
Group Art Unit 2182	Examiner Shin, Christopher B.
Confirmation Number: 5675	

Commissioner for Patents
P.O. Box 1450
Alexandria, VA 22313-1450

Dear Sir:

Certificate of Mailing Under 37 C.F.R. §1.8

I hereby certify that this correspondence is being deposited with the U.S. Postal Service as First Class Mail in an envelope addressed to: Commissioner for Patents, P.O. Box 1450, Alexandria, VA 22313 on **December 15, 2005**.

Julie H. Blackard
Name
JULIE H. BLACKARD

Crossroads Systems, Inc., the owner of one hundred percent (100%) interest in the instant application, as evidenced by the Assignment Recorded on December 31, 1997 on Reel/Frame: 8929/0290 hereby disclaims, except as provided below, the terminal part of the statutory term of any patent granted on the instant application, which would extend beyond the expiration date of the full statutory term defined in 35 U.S.C. § 154 to 156 and 173 of U.S. Patent Nos. 5,941,972, 6,421,753, 6,425,036, 6,425,035, 6,789,152, 6,738,854, and 6,763,419 or shortened by any terminal disclaimer filed prior to the grant of any patent granted on co-pending Application Nos. 90/007,123, 90/007,124, 90/007,125, 90/007,126, 90/007,127, 11/191,254, and 90/007,317. The owner hereby agrees that any patent so granted on the instant application shall be enforceable only for and during such period that it and any patent granted on the co-pending applications are commonly owned. This agreement runs with any patent granted on the instant application and is binding upon the grantee, its successors or assigns.

12/21/2005 DENMANU1 00000034 503183 10658163

01 FC:2814 65.00 DA

In making the above disclaimer, the owner does not disclaim the terminal part of any patent granted on the instant application that would extend to the expiration date of the full statutory term as defined in 35 U.S.C. § 154 to 156 and 173 of the prior patent, as presently shortened by any terminal disclaimer, in the event that it later: expires for failure to pay a maintenance fee, is held unenforceable, is found invalid by a court of competent jurisdiction, is statutorily disclaimed in whole or terminally disclaimed under 37 C.F.R. 1.321, has all claims canceled by a reexamination certificate, is reissued, or is in any manner terminated prior to the expiration of its full statutory term as presently shortened by any terminal disclaimer.

Check box 1, 2, 3, or 4 as appropriate.

1. For submission on behalf of an organization (e.g., corporation, partnership, university, government agency, etc.), the undersigned is empowered to act on behalf of the organization.

I hereby declare that all statements made herein of my own knowledge are true and that all statements made on information and belief are believed to be true; and further that these statements were made with the knowledge that willful false statements and the like so made are punishable by fine or imprisonment, or both, under Section 1001 of Title 18 of the United States Code and that such willful false statements may jeopardize the validity of the application or any patent issued thereon.

* Statement under 37 C.F.R. 3.73(b) is required if terminal disclaimer is signed by the assignee (owner). Form PTO/SB/96 may be used for making this certification. See MPEP § 324.

2. The undersigned is an attorney or agent of record.
3. Terminal disclaimer fee under 37 C.F.R. 1.20(d) included.
4. The Commissioner is hereby authorized to deduct the required fee, and/or any deficiencies or credit any overpayments regarding this application from deposit account 50-3183 of Sprinkle IP Law Group.

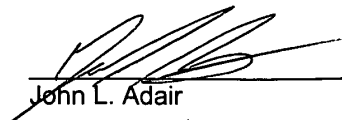
John L. Adair

12/15/05
Dated

10/658163

PATENT APPLICATION FEE DETERMINATION RECORD
Effective January 1, 2003

Application or Docket Number
~~2008163~~

CLAIMS AS FILED - PART I

	(Column 1)	(Column 2)
TOTAL CLAIMS	34	
FOR	NUMBER FILED	NUMBER EXTRA
TOTAL CHARGEABLE CLAIMS	39 minus 20 =	19
INDEPENDENT CLAIMS	7 minus 3 =	4
MULTIPLE DEPENDENT CLAIM PRESENT <input type="checkbox"/>		

* If the difference in column 1 is less than zero, enter "0" in column 2

SMALL ENTITY TYPE <input type="checkbox"/>		OR	OTHER THAN SMALL ENTITY	
RATE	FEE		RATE	FEE
BASIC FEE	375.00	OR	BASIC FEE	750.00
X\$ 9=	121	OR	X\$18=	
X42=	118	OR	X84=	
+140=		OR	+280=	
TOTAL	216	OR	TOTAL	

CLAIMS AS AMENDED - PART II

	(Column 1)	(Column 2)	(Column 3)
AMENDMENT A	CLAIMS REMAINING AFTER AMENDMENT	HIGHEST NUMBER PREVIOUSLY PAID FOR	PRESENT EXTRA
	Total	34 Minus ** 39	=
	Independent	7 Minus *** 7	=
FIRST PRESENTATION OF MULTIPLE DEPENDENT CLAIM <input type="checkbox"/>			

SMALL ENTITY OR		OTHER THAN SMALL ENTITY	
RATE	ADDITIONAL FEE	RATE	ADDITIONAL FEE
X\$ 9=		X\$18=	
X42=		X84=	
+140=		+280=	
TOTAL ADDIT. FEE		OR	TOTAL ADDIT. FEE

	(Column 1)	(Column 2)	(Column 3)
AMENDMENT B	CLAIMS REMAINING AFTER AMENDMENT	HIGHEST NUMBER PREVIOUSLY PAID FOR	PRESENT EXTRA
	Total	34 Minus ** 39	=
	Independent	7 Minus *** 7	=
FIRST PRESENTATION OF MULTIPLE DEPENDENT CLAIM <input type="checkbox"/>			

RATE	ADDITIONAL FEE	RATE	ADDITIONAL FEE
X\$ 9=		X\$18=	
X42=		X84=	
+140=		+280=	
TOTAL ADDIT. FEE		OR	TOTAL ADDIT. FEE

	(Column 1)	(Column 2)	(Column 3)
AMENDMENT C	CLAIMS REMAINING AFTER AMENDMENT	HIGHEST NUMBER PREVIOUSLY PAID FOR	PRESENT EXTRA
	Total		=
	Independent		=
FIRST PRESENTATION OF MULTIPLE DEPENDENT CLAIM <input type="checkbox"/>			

RATE	ADDITIONAL FEE	RATE	ADDITIONAL FEE
X\$ 9=		X\$18=	
X42=		X84=	
+140=		+280=	
TOTAL ADDIT. FEE		OR	TOTAL ADDIT. FEE

* If the entry in column 1 is less than the entry in column 2, write "0" in column 3.
 ** If the "Highest Number Previously Paid For" IN THIS SPACE is less than 20, enter "20."
 *** If the "Highest Number Previously Paid For" IN THIS SPACE is less than 3, enter "3."
 The "Highest Number Previously Paid For" (Total or Independent) is the highest number found in the appropriate box in column 1.

BEST AVAILABLE COPY

Application Number 	Application/Control No. 10/658,163	Applicant(s)/Patent under Reexamination HOESE ET AL.	
Document Code - DISQ		Internal Document – DO NOT MAIL	

TERMINAL DISCLAIMER	<input checked="" type="checkbox"/> APPROVED	<input type="checkbox"/> DISAPPROVED
Date Filed : 122005	This patent is subject to a Terminal Disclaimer	

Approved/Disapproved by:
James R. Matthews

U.S. Patent and Trademark Office



UNITED STATES PATENT AND TRADEMARK OFFICE

A

UNITED STATES DEPARTMENT OF COMMERCE
United States Patent and Trademark Office
Address: COMMISSIONER FOR PATENTS
P.O. Box 1450
Alexandria, Virginia 22313-1450
www.uspto.gov

APPLICATION NO.	FILING DATE	FIRST NAMED INVENTOR	ATTORNEY DOCKET NO.	CONFIRMATION NO.
10/658,163	09/09/2003	Geoffrey B. Hoese	CROSS1120-13	5675
25094	7590	11/01/2005	EXAMINER	
DLA PIPER RUDNICK GRAY CARY US, LLP			SHIN, CHRISTOPHER B	
2000 University Avenue			ART UNIT	PAPER NUMBER
E. Palo Alto, CA 94303-2248			2182	

DATE MAILED: 11/01/2005

Please find below and/or attached an Office communication concerning this application or proceeding.

Office Action Summary	Application No. 10/658,163	Applicant(s) HOESE ET AL.	
	Examiner Christopher B Shin	Art Unit 2182	

-- The MAILING DATE of this communication appears on the cover sheet with the correspondence address --
Period for Reply

A SHORTENED STATUTORY PERIOD FOR REPLY IS SET TO EXPIRE 3 MONTH(S) FROM THE MAILING DATE OF THIS COMMUNICATION.

- Extensions of time may be available under the provisions of 37 CFR 1.136(a). In no event, however, may a reply be timely filed after SIX (6) MONTHS from the mailing date of this communication.
- If the period for reply specified above is less than thirty (30) days, a reply within the statutory minimum of thirty (30) days will be considered timely.
- If NO period for reply is specified above, the maximum statutory period will apply and will expire SIX (6) MONTHS from the mailing date of this communication.
- Failure to reply within the set or extended period for reply will, by statute, cause the application to become ABANDONED (35 U.S.C. § 133). Any reply received by the Office later than three months after the mailing date of this communication, even if timely filed, may reduce any earned patent term adjustment. See 37 CFR 1.704(b).

Status

- 1) Responsive to communication(s) filed on 27 July 2005.
- 2a) This action is FINAL. 2b) This action is non-final.
- 3) Since this application is in condition for allowance except for formal matters, prosecution as to the merits is closed in accordance with the practice under *Ex parte Quayle*, 1935 C.D. 11, 453 O.G. 213.

Disposition of Claims

- 4) Claim(s) 15-53 is/are pending in the application.
 - 4a) Of the above claim(s) _____ is/are withdrawn from consideration.
- 5) Claim(s) _____ is/are allowed.
- 6) Claim(s) 15-53 is/are rejected.
- 7) Claim(s) _____ is/are objected to.
- 8) Claim(s) _____ are subject to restriction and/or election requirement.

Application Papers

- 9) The specification is objected to by the Examiner.
- 10) The drawing(s) filed on 09 September 2003 is/are: a) accepted or b) objected to by the Examiner.
 - Applicant may not request that any objection to the drawing(s) be held in abeyance. See 37 CFR 1.85(a).
 - Replacement drawing sheet(s) including the correction is required if the drawing(s) is objected to. See 37 CFR 1.121(d).
- 11) The oath or declaration is objected to by the Examiner. Note the attached Office Action or form PTO-152.

Priority under 35 U.S.C. § 119

- 12) Acknowledgment is made of a claim for foreign priority under 35 U.S.C. § 119(a)-(d) or (f).
 - a) All b) Some * c) None of:
 - 1. Certified copies of the priority documents have been received.
 - 2. Certified copies of the priority documents have been received in Application No. _____.
 - 3. Copies of the certified copies of the priority documents have been received in this National Stage application from the International Bureau (PCT Rule 17.2(a)).
- * See the attached detailed Office action for a list of the certified copies not received.

Attachment(s)

- 1) Notice of References Cited (PTO-892)
- 2) Notice of Draftsperson's Patent Drawing Review (PTO-948)
- 3) Information Disclosure Statement(s) (PTO-1449 or PTO/SB/08)
Paper No(s)/Mail Date 07252005.
- 4) Interview Summary (PTO-413)
Paper No(s)/Mail Date. _____.
- 5) Notice of Informal Patent Application (PTO-152)
- 6) Other: _____.

DETAILED ACTION

1. The amendment received July 27, 2005 has been entered and carefully considered. Claims 15-53 and the applicant's responses were carefully considered.

Interview/Double Patenting Rejection

2. On October 25, 2005, a telephonic interview was conducted and the applicant agreed to file additional Terminal Disclaimer against all of the remaining related pending applications and allowed applications. During the interview, the examiner also kindly asks the applicant to make sure that the present and pending applications to be consistent with the related reexamination applications.

3. The nonstatutory double patenting rejection is based on a judicially created doctrine grounded in public policy (a policy reflected in the statute) so as to prevent the unjustified or improper timewise extension of the "right to exclude" granted by a patent and to prevent possible harassment by multiple assignees. See *In re Goodman*, 11 F.3d 1046, 29 USPQ2d 2010 (Fed. Cir. 1993); *In re Longi*, 759 F.2d 887, 225 USPQ 645 (Fed. Cir. 1985); *In re Van Ornum*, 686 F.2d 937, 214 USPQ 761 (CCPA 1982); *In re Vogel*, 422 F.2d 438, 164 USPQ 619 (CCPA 1970); and, *In re Thorington*, 418 F.2d 528, 163 USPQ 644 (CCPA 1969).

A timely filed terminal disclaimer in compliance with 37 CFR 1.321(c) may be used to overcome an actual or provisional rejection based on a nonstatutory double patenting ground provided the conflicting application or patent is shown to be commonly owned with this application. See 37 CFR 1.130(b).

Effective January 1, 1994, a registered attorney or agent of record may sign a terminal disclaimer. A terminal disclaimer signed by the assignee must fully comply with 37 CFR 3.73(b).

a. Since the applicant agreed with the examiner regarding the Double Patenting rejection, the details of the rejection would be omitted.

b. The examiner kindly asks the applicant for help on identifying all of the related applications, if the examiner inadvertently makes a mistake. Claim15-53 are rejected under the judicially created doctrine of obviousness-type double patenting as being unpatentable over claims of the related Patent/Applications as follows. Although the conflicting claims are not identical, they are not patentably distinct from each other because the related applications claim subject matter that are substantially identical to the present claimed invention. The following are the list of the related cases:

09/001,799; 09/354,682; 10/081,110; 10/081,114; 10/023,786;
10/081,110; 09/965,335; 10/174,720; 09/965,339; 10/081,082;
10/361,283; 10/638,955; 10/640,468; 10/658,163; 11/191,254;
90/007,123; 90/007,124; 90/007,125; 90/007,126; 90/007,127;&
90/007,327.

Conclusion

4. **THIS ACTION IS MADE FINAL.** Applicant is reminded of the extension of time policy as set forth in 37 CFR 1.136(a).

A shortened statutory period for reply to this final action is set to expire **THREE MONTHS** from the mailing date of this action. In the event a first reply is filed within **TWO MONTHS** of the mailing date of this final action and the advisory action is not mailed until after the end of the **THREE-MONTH** shortened statutory period, then the shortened statutory period will expire on the date the advisory action is mailed, and any extension fee pursuant to 37 CFR 1.136(a) will be calculated from the mailing date of

the advisory action. In no event, however, will the statutory period for reply expire later than SIX MONTHS from the mailing date of this final action.

5. Any inquiry concerning this communication or earlier communications from the examiner should be directed to Christopher B. Shin whose telephone number is 571-272-4159. The examiner can normally be reached on 6:30-5:00 M,Tu,Th,F.

If attempts to reach the examiner by telephone are unsuccessful, the examiner's supervisor, Kim Huynh can be reached on 571-272-4147. The fax phone number for the organization where this application or proceeding is assigned is 571-273-8300.

Information regarding the status of an application may be obtained from the Patent Application Information Retrieval (PAIR) system. Status information for published applications may be obtained from either Private PAIR or Public PAIR. Status information for unpublished applications is available through Private PAIR only. For more information about the PAIR system, see <http://pair-direct.uspto.gov>. Should you have questions on access to the Private PAIR system, contact the Electronic Business Center (EBC) at 866-217-9197 (toll-free).

CHRISTOPHER SHIN
PRIMARY EXAMINER
OF 2182

October 26, 2005
cbs



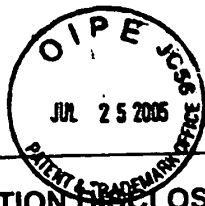

PTO/SB/08A (04-03)

INFORMATION DISCLOSURE STATEMENT BY APPLICANT		Application Number		10/658,163	
		Filing Date		09/09/2003	
		First Named Inventor		Hoese, Geoffrey	
		Group Art Unit		2182	
		Examiner Name		Shin, Christopher B.	
Sheet	1	OF	4	Attorney Docket Number	CROSS1120-13

U.S. PATENT DOCUMENTS

Examiner Initials	Cite No.	Document Number		Publication Date MM-DD-YYYY	Name of Patentee or Applicant of Cited Document	Pages, Columns, Lines Where Relevant Passages or Figures Appear
		Number	Kind Code (if known)			
S	A1	4,415,970		11/15/1983	Swenson, et al.	
	A2	4,455,605		6/19/1984	Cormier, et al.	
	A3	4,504,927		3/12/1985	Callan	
	A4	4,533,996		8/6/1985	Gartung, et al.	
	A5	4,573,152		2/25/1986	Greene, et al.	
	A6	4,603,380		7/29/1986	Easton, et al.	
	A7	4,620,295		10/28/1986	Aiden, Jr.	
	A8	4,644,462		2/17/1987	Matsubara, et al.	
	A9	4,697,232		9/29/1987	Brunelle, et al.	
	A10	4,787,028		11/22/1988	Finforck, et al.	
	A11	4,807,180		2/21/1989	Takeuchi, et al.	
	A12	4,811,278		3/7/1989	Bean, et al.	
	A13	4,821,179		4/11/1989	Jensen, et al.	
	A14	4,825,406		4/25/1989	Bean, et al.	
	A15	4,827,411		5/2/1989	Arrowood, et al.	
	A16	4,835,674		5/30/1989	Collins, et al.	
	A17	4,864,532		9/5/1989	Reeve, et al.	
	A18	4,897,874		1/30/1990	Lidensky, et al.	
	A19	4,961,224		10/2/1990	Yung	
	A20	5,072,378		12/10/1991	Manka	
	A21	5,077,732		12/31/1991	Fischer, et al.	
	A22	5,077,736		12/31/1991	Dunphy, Jr., et al.	
	A23	5,124,987		6/23/1992	Milligan, et al.	
	A24	5,155,845		10/13/1992	Beal, et al.	
	A25	5,185,876		2/9/1993	Nguyen, et al.	
	A26	5,193,168		3/9/1993	Corrigan, et al.	
	A27	5,193,184		3/9/1993	Belsan, et al.	
	A28	5,202,856		4/13/1993	Glider, et al.	

✓	A29	5,210,866		5/11/1993	Milligan, et al.	
	A30	5,212,785		5/18/1993	Powers, et al.	
	A31	5,214,778		5/25/1993	Glider, et al.	
	A32	5,226,143		7/6/1993	Baird, et al.	
	A33	6,239,632		08/24/93	Lamer	
	A34	5,239,654		8/24/1993	Ing-Simmons	
	A35	5,247,638		9/21/1993	O'Brien, et al.	
	A36	5,247,692		9/21/1993	Fujimura	
	A37	5,297,262		3/22/1994	Cox, et al.	
	A38	5,301,290		4/5/1994	Tetzlaff, et al.	
	A39	5,315,657		5/24/2994	Abadi, et al.	
	A40	5,317,693		7/19/1994	Elko, et al.	
	A41	5,331,673		7/19/1994	Elko, et al.	
	A42	5,361,347		11/1/1994	Glider, et al.	
	A43	5,367,646		11/22/1994	Pardillos, et al.	
	A44	5,379,385		1/3/1995	Shomler	
	A45	5,379,398		1/3/1995	Cohn, et al.	
	A46	5,388,243		2/7/1995	Gilder, et al.	
	A47	5,388,246		2/7/1995	Kasi	
	A48	5,394,526		2/28/1995	Crouse et al.	
	A49	5,396,596		3/7/1995	Hashemi, et al.	
	A50	5,403,639		4/4/1995	Belsan, et al.	
	A51	5,410,667		4/25/1995	Belsan, et al.	
	A52	5,410,697		4/25/1995	Baird, et al.	
	A53	5,416,915		5/16/1995	Mattson, et al.	
	A54	5,418,909		5/23/1995	Jachowski, et al.	
	A55	5,420,988		5/30/1995	Elliott	
	A56	5,423,026		6/6/1995	Cook, et al.	
	A57	5,426,637		6/20/1995	Derby, et al	
	A58	5,430,855		7/4/1995	Wash, et al.	
	A59	5,450,570		9/12/1995	Richek, et al.	
	A60	5,452,421		9/19/1995	Beardsley, et al.	
	A61	5,459,857		10/17/1995	Ludlam, et al.	
	A62	5,463,754		10/31/1995	Beausoleil, et al.	
	A63	5,469,576		11/21/1995	Dauerer, et al.	
	A64	5,471,609		11/28/1995	Yudenfriend	
	A65	5,487,077		1/23/1996	Hassner, et al.	
	A66	5,495,474		2/27/1996	Olnowich, et al.	
✓	A67	5,496,576		3/5/1996	Jeong	

✓	A68	5,504,857		4/2/1996	Baird, et al.
	A69	5,507,032		4/9/1996	Kimura
	A70	5,511,169		4/23/1996	Suda
	A71	5,519,695		5/21/1996	Purohit, et al.
	A72	5,530,845		6/25/1996	Hiatt, et al.
	A73	5,535,352		7/9/1996	Bridges, et al.
	A74	5,537,585		7/16/1996	Blickerstaff, et al.
	A75	5,544,313		8/6/1996	Shachnai, et al.
	A76	5,548,791		8/20/1996	Casper, et al.
	A77	5,564,019		10/8/1996	Beausoleil, et al.
	A78	5,568,648		10/22/1996	Coscarella, et al.
	A79	5,581,709		12/3/1996	Ito, et al.
	A80	5,581,724		12/3/1996	Belsan et al.
	A81	5,613,082		3/18/1997	Brewer, et al.
	A82	5,621,902		4/15/1997	Cases, et al.
	A83	5,632,012		5/20/1997	Belsan, et al.
	A84	5,634,111		5/27/1997	Oeda, et al.
	A85	5,638,518		6/10/1997	Malladi
	A86	5,642,515		6/24/1997	Jones, et al.
	A87	5,659,756		8/19/1997	hefferon, et al.
	A88	5,664,107		9/2/1997	Chatwanni, et al.
	A89	5,727,218		3/10/1998	Hotchkin
	A90	5,743,847		4/28/1998	Nakamura, et al.
	A91	5,781,715		7/14/1998	Sheu
	A92	5,802,278		9/1/1998	Isfeld, et al.
	A93	5,805,816		9/8/1998	Picazo, Jr., et al.
	A94	5,860,137		1/12/1999	Raz, et al.
	A95	5,867,648		2/2/1999	Foth, et al.
	A96	5,889,952		3/30/1999	Hunnicut, et al.
	A97	5,913,045		6/15/1999	Gillespie, et al.
	A98	5,923,557		7/13/1999	Eidson
	A99	5,933,824		8/3/1999	DeKoning, et al.
	A100	5,935,260		8/10/1999	Ofer
	A101	5,949,994		9/28/1999	Boggs, et al.
	A102	5,953,511		9/14/1999	Sescilia, et al.
	A103	5,959,994		9/28/1999	Boggs, et al.
	A104	5,974,530		10/26/1999	Young
	A105	6,021,451		2/1/2000	Bell, et al.
✓	A106	6,055,603		4/25/2000	Ofer, et al.

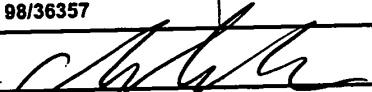
	A107	6,065,087			5/16/2000	Keaveny, et al.			
	A108	6,073,218			6/6/2000	DeKoning, et al.			
	A109	6,075,863			6/13/2000	Krishnan, et al.			
	A110	6,081,849			6/27/2000	Born, et al.			
	A111	6,098,149			8/1/2000	Ofer, et al.			
	A112	6,108,684			8/22/2000	DeKoning, et al.			
	A113	6,118,766			9/12/2000	Akers			
	A114	6,148,004			11/14/2000	Nelson, et al.			
	A115	6,209,023			3/27/2001	Dimitroff, et al.			
	A116	6,230,218			5/8/2001	Casper, et al.			
	A117	6,341,315			1/22/2002	Arroyo, et al.			
	A118	6,343,324			1/29/2002	Hubis, et al.			
	A119	6,425,036			7/23/2002	Hoese, et al.			
	A120	6,484,245			11/19/2002	Sanada, et al.			
Examiner Initials	FOREIGN PATENT DOCUMENTS			Country Code	Number	Kind Code (if known)	Publication Date MM-DD-YYYY (Number 43)	Name of Patentee or Applicant of Cited Document	Pages, Columns, Lines Where Relevant Passages or Figures Appear
	B1	GB 2341715							
	B2	JP 6301607							
	B3	WO 98/36357				1998			
Examiner Signature						Date Considered	10-25-05		

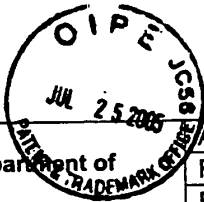

FORM PTO 1449 US Department of Commerce Patent and Trademark Office			Application Number	10/658,163
			Filing Date	09/09/2003
			First Named Inventor	Geoffrey B. Hoese
			Group Art Unit	2182
			Examiner Name	Shin, Christopher B.
Sheet 1	of 7	Atty Docket Number	CROSS1120-13	
Examiner Initials	Cite No.	OTHER PRIOR ART – NON PATENT LITERATURE DOCUMENTS		Date
JS	C1	Decision Returning Petition mailed February 28, 2005		
	C2	Block-Based Distributed File Systems, Anthony J. McGregor, July 1997		
	C3	Compaq StorageWorks HSG80 Array Controller ACS Version 8.3 (Maintenance and Service Guide) 11/98		
	C4	Compaq StorageWorks HSG80 Array Controller ACS Version 8.3 (Configuration and CLI Reference Guide) 11/98		
	C5	CRD-5500 SCSI RAID Controller User's Manual CMD Technology, Inc. pp. 1-1 to 6-25, revised November 21, 1996.		11/21/1996
	C6	DIGITAL Storage Works, HSZ70 Array Controller, HSOF Version 7.0 EK-HSZ70-CG. A01, Digital Equipment Corporation, Maynard, Massachusetts		
	C7	DIGITAL StorageWorks HSZ70 Array Controller HSOF Version 7.0 EK-HSZ270-RM. A01 CLI Reference Manual		
	C8	DIGITAL StorageWorks HSZ70 Array Controller HSOF Version 7.0 EK-HSZ70-SV. A01		1997-
	C9	DIGITAL StorageWorks HSG80 Array Controller ACS Version 8.0 (User's Guide 1/98)		
	C10	DP5380 Asynchronous SCSI Interface, National Semiconductor Corporation, Arlington, TX, May 1989, pp. 1-32		
	C11	Emerson, "Ancor Communications: Performance evaluation of switched fibre channel I/O system using—FCP for SCSI" February 1995, IEEE, pp. 479-484		2/1/1995
	C12	Fibre Channel and ATM: The Physical Layers, Jerry Quam WESCON/94, published 27-29 September 1994. Pages 648-652.		
	C13	Fiber Channel storage interface for video-on-demand servers by Anzaloni, et al.		6/15/1905
	C14	Gen5 S-Series XL System Guide Revision 1.01 by Chen		6/18/1905
	C15	Graphical User Interface for MAXSTRAT Gen5/Gen-S Servers User's guide 1.1		6/11/1996
	C16	High Performance Data transfers Using Network-Attached Peripherals at the national Storage Laboratory by Hyer		2/26/1993
	C17	IFT-3000 SCSI to SCSI Disk array Controller Instruction Manual Revision 2.0 by Infotrend Technologies, Inc.		1995-
	C18	Implementing a Fibre Channel SCSI transport by Snively		1994-
	C19	"InfoServer 150—Installation and Owner's Guide", EK-INFSV-OM-001, Digital Equipment Corporation, Maynard, Massachusetts 1991, Chapters 1 and 2		
	C20	InfoServer 150VXT Photograph		
	C21	Infoserver 100 System Operations Guide, First Edition Digital Equipment Corporation, 1990		
	C22	Johnson, D.B., et al., "The Peregrine High Performance RPC System", Software-Practice and Experience, 23(2):201-221, Feb. 1993		
	C23	Local-Area networks for the IBM PC by Haugdahl		
	C24	Misc. Reference Manual Pages, SunOS 5.09		

FORM PTO 1449 US Department of Commerce Patent and Trademark Office			Application Number	10/658,163	
			Filing Date	09/09/2003	
			First Named Inventor	Geoffrey B. Hoese	
			Group Art Unit	2182	
			Examiner Name	Shin, Christopher B.	
Sheet	2	of	7	Atty Docket Number	CROSS1120-13
Examiner Initials	Cite No.	OTHER PRIOR ART -- NON PATENT LITERATURE DOCUMENTS		Date	
	C25	New serial I/Os speed storage subsystems by Bursky		2/6/1995	
	C26	Petal: Distributed Virtual Disks, Edward K. Lee and Chandramohan A. Thekkath, ACM SIGPLAN Notices, Volume 31, Issue 9, September 1996, pages 84-92.			
	C27	Pictures of internal components of the InfoServer 150, taken from http://bindarydinosaurs.couk/Museum/Digital/infoserver/infoserver.php in Nov. 2004.			
	C28	Raidtec FibreArray and Raidtec FlexArray UltraRAID Systems", Windows IT PRO Article, October 1997			
	C29	S.P. Joshi, "Ethernet controller chip interfaces with variety of 16-bit processors," electronic Design, Hayden Publishing Co., Inc., Rochelle Part, NJ, October 14, 1982. pp 193-200			
	C30	Simplest Migration to Fibre Channel Technology" Article, Digital Equipment Corporation, November 10, 1997, published on PR Newswire		11/10/1997	
	C31	Systems Architectures Using Fibre Channel, Roger Cummings, Twelfth IEEE Symposium on Mass Storage Systems, Copyright 1993 IEEE. Pages 251-256			
	C32	Dot Hill's Request to Exceed Page Limit in Motion for Summary Judgment filed June 29, 2005. Case No. A-03-CV-754 (SS)			
	C33	Request for Ex Parte Reexamination for 6,425,035. Third Party Requester: William A. Blake			
	C34	Request for Ex Parte Reexamination for 6,425,035. Third Party Requester: Natu J. Patel			
	C35	Office Action dated 01/21/03 for 10/174,720 (CROSS1120-8)		1/21/2003	
	C36	Office Action dated 02/27/01 for 09/354,682 (CROSS1120-1)		2/27/2001	
	C37	Office Action dated 08/11/00 for 09/354,682 (CROSS1120-1)		8/11/2000	
	C38	Office Action dated 12/16/99 for 09/354,682 (CROSS1120-1)		12/16/1999	
	C39	Office Action dated 11/06/02 for 10/023,786 (CROSS1120-4)		11/6/2002	
	C40	Office Action dated 01/21/03 for 10/081,110 (CROSS1120-5)		1/21/2003	
	C41	Office Action in Ex Parte Reexamination 90/007,127, mailed 02/07/05.		2/7/2005	
	C42	Reply to Office Action Under Ex Parte Reexamination Dated 02/02/07 for 90/007,127 filed on 04/06/05.			
	C43	Office Action in Ex Parte Reexamination 90/007,125, mailed 02/07/05.		2/7/2005	
	C44	Reply to Office Action Under Ex Parte Reexamination Dated 02/02/07 for 90/007,125 and 90/007,317 filed on 04/06/05.			
	C45	Office Action in Ex Parte Reexamination 90/007,126, mailed 02/07/05.		2/7/2005	
	C46	Reply to Office Action Under Ex Parte Reexamination Dated 02/02/07 for 90/007,126 filed on 04/06/05.			
	C47	Office Action in Ex Parte Reexamination 90/007,124, mailed 02/07/05.		2/7/2005	
	C48	Reply to Office Action Under Ex Parte Reexamination Dated 02/02/07 for 90/007,124 filed on 04/06/05.			
	C49	Office Action in Ex Parte Reexamination 90/007,123, mailed 02/07/05.		2/7/2005	

FORM PTO 1449 US Department of Commerce Patent and Trademark Office			Application Number	10/658,163	
			Filing Date	09/09/2003	
			First Named Inventor	Geoffrey B. Hoese	
			Group Art Unit	2182	
			Examiner Name	Shin, Christopher B.	
Sheet	3	of	7	Atty Docket Number	CROSS1120-13
Examiner Initials	Cite No.	OTHER PRIOR ART – NON PATENT LITERATURE DOCUMENTS			Date
	C50	Reply to Office Action Under Ex Parte Reexamination Dated 02/02/07 for 90/007,123 filed on 04/05/05.			
	C51	European Office Action issued April 1, 2004 in Application No. 98966104.6-2413			4/1/2004
	C52	Fiber Channel (FCS)/ATM Interworking: A Design Solution by Anzaloni, et al.			
		Copies of the following are on the attached CD-Rom			
	C53	Defendant's First Supplemental Trial Exhibit List, Crossroads Systems, Inc., v. Chaparral Network Storage, Inc., C.A. No. A-00CA-217-SS (W.D. Tex. 2001). (CD-Rom) .			
	C54	Defendant's Third Supplemental Trial Exhibit List, Crossroads Systems, Inc. v. Pathlight Technology, Inc., C.A. No. A-00CA-248-SS (W.D. Tex. 2001) (CD-Rom) .			
	C55	Defendant Chaparral Network Storage, Inc.'s First Supplemental Trial Exhibit List (D1 through D271) (CD-ROM Chaparral Exhibits ExList Def) .			9/2/2001
	C56	Plaintiff's Fourth Amended Trail Exhibit List, Crossroads Systems, Inc. v. Chaparral Network Storage, Inc, C.A. No. A-00CA-217-SS (W.D. Tex. 2001) (CD-Rom) .			9/11/2001
	C57	Plaintiff's Revised Trial Exhibit List, Crossroads Systems, Inc. v. Pathlight Technology, Inc., C.A. No. A-00CA-248-SS (W.D. Tex. 2001). (CD-Rom) .			
	C58	Trail Transcripts, Crossroads Systems, Inc. v. Chaparral Network Storage, Inc., C.A. No. A-00CA-217-SS (W.D. Tex. 2001) (CD-Rom) .			
	C59	Trail Transcripts, Crossroads Systems, Inc. v. Pathlight Technology, Inc., C.A. No. A-00CA-248-SS (W.D. Tex. 2001). (CD-Rom) .			

FORM PTO 1449 US Department of Commerce Patent and Trademark Office				Application Number	10/658,163
				Filing Date	09/09/2003
				First Named Inventor	Geoffrey B. Hoesse
				Group Art Unit	2182
				Examiner Name	Shin, Christopher B.
Sheet	4	of	7	Atty Docket Number	CROSS1120-13
Examiner Initials	Cite No.	OTHER PRIOR ART – NON PATENT LITERATURE DOCUMENTS			Date
	C60	Datasheet for CrossPoint 4100 Fibre Channel to SCSI Router (Dedek Ex 41 (ANCT 117-120)) (CD-ROM Chaparral Exhibits D012).			
	C61	Symbios Logic- Software Interface Specification Series 3 SCSI RAID Controller Software Release 02.xx (Engelbrecht Ex 2 (LSI 1421-1658)) (CD-ROM Chaparral Exhibits D013).			12/3/1997
	C62	Press Release- Symbios Logic to Demonstrate Strong Support for Fibre Channel at Fall Comdex (Engelbrecht 12 (LSI 2785-86)) (CD-ROM Chaparral Exhibits D016).			11/13/1996
	C63	OEM Datasheet on the 3701 Controller (Engelbrecht 13 (LSI 01837-38)) (CD-ROM Chaparral Exhibits D017).			6/17/1905
	C64	Nondisclosure Agreement Between Adaptec and Crossroads Dated 10/17/96 (Quisenberry Ex 25 (CRDS 8196)) (CD-ROM Chaparral Exhibits D020).			10/17/1996
	C65	Organizational Presentation on the External Storage Group (Lavan Ex 1 (CNS 182242-255)) (CD-ROM Chaparral Exhibits D021).			4/11/1996
	C66	Bridge. C, Bridge Between SCSI-2 and SCSI-3 FCP (Fibre Channel Protocol) (CD-ROM Chaparral Exhibits P214).			
	C67	Bridge Phase II Architecture Presentation (Lavan Ex 2 (CNS 182287-295)) (CD-ROM Chaparral Exhibits D022).			4/12/1996
	C68	Attendees/Action Items from 4/12/96 Meeting at BTC (Lavan Ex 3 (CNS 182241)) (CD-ROM Chaparral Exhibits D023).			4/12/1996
	C69	Brooklyn Hardware Engineering Requirements Documents, Revision 1.4 (Lavan Ex 4 (CNS 178188-211)) (CD-ROM Chaparral Exhibits D024) by Pecone.			5/26/1996
	C70	Brooklyn Single-Ended SCSI RAID Bridge Controller Hardware OEM Manual, Revision 2.1 (Lavan EX 5 (CNS 177169-191)) (CD-ROM Chaparral Exhibits D025).			3/21/1996
	C71	Coronado Hardware Engineering Requirements Document, Revision 0.0 (Lavan Ex 7 (CNS 176917-932)) (CD-ROM Chaparral Exhibits D027) by O'Dell.			9/30/1996
	C72	ESS/FPG Organization (Lavan Ex 8 (CNS 178639-652)) (CD-ROM Chaparral Exhibits D028).			12/6/1996
	C73	Adaptec MCS ESS Presents: Intelligent External I/O Raid Controllers "Bridge" Strategy (Lavan Ex 9 (CNS 178606-638)). (CD-ROM Chaparral Exhibits D029).			2/6/1996
	C74	AEC-7313 Fibre Channel Daughter Board (for Brooklyn) Engineering Specification, Revision 1.0 (Lavan Ex 10 (CNS 176830-850)) (CD-ROM Chaparral Exhibits D030).			2/27/1997
	C75	Bill of Material (Lavan Ex 14 (CNS 177211-214)) (CD-ROM Chaparral Exhibits D034).			7/24/1997
	C76	AEC- 4412B, AEC-7412/B2 External RAID Controller Hardware OEM Manual, Revision 2.0 (Lavan Ex 15 (CNS 177082-123)) (CD-ROM Chaparral Exhibits D035).			6/27/1997

FORM PTO 1449 US Department of Commerce Patent and Trademark Office			Application Number	10/658,163	
			Filing Date	09/09/2003	
			First Named Inventor	Geoffrey B. Hoese	
			Group Art Unit	2182	
			Examiner Name	Shin, Christopher B.	
Sheet	5	of	7	Atty Docket Number	CROSS1120-13
Examiner Initials	Cite No.	OTHER PRIOR ART -- NON PATENT LITERATURE DOCUMENTS			Date
S ↓	C77	Coronado II, AEC-7312A Fibre Channel Daughter (for Brooklyn) Hardware Specification, Revision 1.2 (Lavan Ex 16 (CNS 177192-210)) (CD-ROM Chaparral Exhibits D036) by Tom Yang.			7/18/1997
	C78	AEC-4412B, AEC7412/3B External RAID Controller Hardware OEM Manual, Revision 3.0. (Lavan Ex 17 (CNS 177124-165)) (CD-ROM Chaparral Exhibits D037).			8/25/1997
	C79	Memo Dated 8/15/97 to AEC-7312A Evaluation Unit Customers re: B001 Release Notes (Lavan Ex 18 (CNS 182878-879)) (CD-ROM Chaparral Exhibits D038).			8/15/1997
	C80	Brooklyn Main Board (AES-0302) MES Schedule (Lavan Ex 19 (CNS 177759-763)) (CD-ROM Chaparral Exhibits D039).			2/11/1997
	C81	News Release-Adaptec Adds Fibre Channel Option to its External RAID Controller Family (Lavan Ex 20 (CNS 182932-934)) (CD-ROM Chaparral Exhibits D040).			5/6/1997
	C82	AEC-4412B/7412B User's Guide, Rev. A (Lavan Ex 21) (CD-ROM Chaparral Exhibits D041).			6/19/1995
	C83	Data Book- AIC-7895 PCI Bus Master Single Chip SCSI Host Adapter (Davies Ex 1 (CNS 182944-64)) (CD-ROM Chaparral Exhibits D046).			5/21/1996
	C84	Data Book- AIC-1160 Fibre Channel Host Adapter ASIC (Davies Ex 2 (CNS 181800-825)) (CD-ROM Chaparral Exhibits D047).			6/18/1995
	C85	Viking RAID Software (Davies Ex 3 (CNS 180969-181026)) (CD-ROM Chaparral Exhibits D048).			6/18/1995
	C86	Header File with Structure Definitions (Davies Ex 4 (CNS 180009-018)) (CD-ROM Chaparral Exhibits D049).			8/8/1996
	C87	C++ SourceCode for the SCSI Command Handler (Davies Ex 5 (CNS 179136-168)) (CD-ROM Chaparral Exhibits D050).			8/8/1996
	C88	Header File Data Structure (Davies Ex 6 (CNS 179997-180008)) (CD-ROM Chaparral Exhibits D051).			1/2/1997
	C89	SCSI Command Handler (Davies Ex 7 (CNS 179676-719)) (CD-ROM Chaparral Exhibits D052).			1/2/1997
	C90	Coronado: Fibre Channel to SCSI Intelligent RAID Controller Product Brief (Kalwitz Ex 1 (CNS 182804-805)) (CD-ROM Chaparral Exhibits D053).			
	C91	Bill of Material (Kalwitz Ex 2 (CNS 181632-633)) (CD-ROM Chaparral Exhibits D054).			3/17/1997
	C92	Emails Dated 1/13-3/31/97 from P. Collins to Mo re: Status Reports (Kalwitz Ex 3 (CNS 182501-511)) (CD-ROM Chaparral Exhibits D055).			
	C93	Hardware Schematics for the Fibre Channel Daughtercard Coronado (Kalwitz Ex 4 (CNS 181639-648)) (CD-ROM Chaparral Exhibits D056).			
	C94	Adaptec Schematics re AAC-340 (Kalwitz Ex 14 CNS 177215-251)) (CD-ROM Chaparral Exhibits D057).			
	C95	Bridge Product Line Review (Manzanares Ex 3 (CNS 177307-336)) (CD-ROM Chaparral Exhibits D058).			
C96	AEC Bridge Series Products-Adaptec External Controller RAID Products Pre-Release Draft, v.6 (Manzanares Ex 4 (CNS 174632-653)). (CD-ROM Chaparral Exhibits D059).			10/28/1997	

FORM PTO 1449 US Department of Commerce Patent and Trademark Office			Application Number	10/658,163	
			Filing Date	09/09/2003	
			First Named Inventor	Geoffrey B. Hoese	
			Group Art Unit	2182	
			Examiner Name	Shin, Christopher B.	
Sheet	6	of	7	Atty Docket Number	CROSS1120-13
Examiner Initials	Cite No.	OTHER PRIOR ART – NON PATENT LITERATURE DOCUMENTS		Date	
<i>CS</i>	C97	Hewlett-Packard Roseville Site Property Pass for Brian Smith (Dunning Ex 14 (HP 489) (CD-ROM Chaparral Exhibits D078).		11/7/1996	
	C98	Distribution Agreement Between Hewlett-Packard and Crossroads (Dunning Ex 15 (HP 326-33) (CD-ROM Chaparral Exhibits D079).			
	C99	HPFC-5000 Tachyon User's Manuel, First Edition (PTI 172419-839) (CD-ROM Chaparral Exhibits D084).		5/1/1996	
	C100	X3T10 994D - (Draft) Information Technology: SCSI-3 Architecture Model, Rev. 1.8 (PTI 165977) (CD-ROM Chaparral Exhibits D087).			
	C101	X3T10 Project 1047D: Information Technology- SCSI-3 Controller Commands (SCC), Rev. 6c (PTI 166400-546) (CD-ROM Chaparral Exhibits D088).		9/3/1996	
	C102	X3T10 995D- (Draft) SCSI-3 Primary Commands, Rev. 11 (Wanamaker Ex 5 (PTI 166050-229)) (CD-ROM Chaparral Exhibits D089).		11/13/1996	
	C103	VBAR Volume Backup and Restore (CRDS 12200-202) (CD-ROM Chaparral Exhibits D099).			
	C104	Preliminary Product Literature for Infinity Commstor's Fibre Channel to SCSI Protocol Bridge (Smith Ex 11; Quisenberry Ex 31 (SPLO 428-30) (CD-ROM Chaparral Exhibits D143).		8/19/1996	
	C105	Letter dated 7/12/96 from J. Boykin to B. Smith re: Purchase Order for Evaluation Units from Crossroads (Smith Ex 24) CRDS 8556-57) (CD-ROM Chaparral Exhibits D144).		7/12/1996	
	C106	CrossPoint 4100 Fibre Channel to SCSI Router Preliminary Datasheet (Hulsey Ex 9 (CRDS 16129-130)) (CD-ROM Chaparral Exhibits D145).		11/1/1996	
	C107	CrossPoint 4400 Fibre Channel to SCSI Router Preliminary Datasheet (Bardach Ex. 9, Quisenberry Ex 33 (CRDS 25606-607)) (CD-ROM Chaparral Exhibits D153).		11/1/1996	
	C108	Fax Dated 07/22/96 from L. Petti to B. Smith re: Purchase Order from Data General for FC2S Fibre to Channel SCSI Protocol Bridge Model 11 (Smith Ex 25; Quisenberry Ex 23; Bardach Ex 11 (CRDS 8552-55; 8558) (CD-ROM Chaparral Exhibits D155).			
	C109	Email Dated 12/20/96 from J. Boykin to B. Smith re: Purchase Order for Betas in February and March (Hoese Ex 16, Quisenberry Ex 25; Bardach Ex 12 (CRDS 13644-650) (CD-ROM Chaparral Exhibits D156).			
	C110	Infinity Commstor Fibre Channel Demo for Fall Comdex, 1996 (Hoese Ex 15, Bardach Ex 13 (CRDS 27415) (CD-ROM Chaparral Exhibits D157).			
	C111	Fax Dated 12/19/96 from B. Bardach to T. Rarich re: Purchase Order Information (Bardach Ex. 14; Smith Ex 16 (CRDS 4460)) (CD-ROM Chaparral Exhibits D158).			
	C112	Miscellaneous Documents Regarding Comdex (Quisenberry Ex 2 (CRDS 27415-465)) (CD-ROM Chaparral Exhibits D165).			
	C113	CrossPoint 4100 Fibre Channel to SCSI Router Preliminary Datasheet (Quisenberry) Ex 3 (CRDS 4933-34) (CD-ROM Chaparral Exhibits D166) (CD-ROM Chaparral Exhibits D166).			

FORM PTO 1449 US Department of Commerce Patent and Trademark Office				Application Number	10/658,163	
				Filing Date	09/09/2003	
				First Named Inventor	Geoffrey B. Hoese	
				Group Art Unit	2182	
				Examiner Name	Shin, Christopher B.	
Sheet	7	of	7	Atty Docket Number	CROSS1120-13	
Examiner Initials	Cite No.	OTHER PRIOR ART -- NON PATENT LITERATURE DOCUMENTS			Date	
	C114	CrossPoint 4400 Fibre to Channel to SCSI Router Preliminary Datasheet; Crossroads Company and Product Overview (Quisenberry Ex 4 (CRDS 25606; 16136)) (CD-ROM Chaparral Exhibits D167).				
	C115	Crossroads Purchase Order Log (Quisenberry Ex 9 (CRDS 14061-062)) (CD-ROM Chaparral Exhibits D172).				
	C116	RAID Manager 5 with RDAC 5 for UNIX V.4 User's Guide (LSI-01854) (CD-ROM Chaparral Exhibits P062).			9/1/1996	
	C117	Letter dated May 12, 1997 from Alan G. Leal to Barbara Bardach enclosing the original OEM License and Purchase Agreement between Hewlett-Packard Company and Crossroads Systems, Inc. (CRDS 02057) (CD-ROM Chaparral Exhibits P130).				
	C118	CR4x00 Product Specification (CRDS 43929) (CD-ROM Chaparral Exhibits P267).			6/1/1998	
	C119	Symbios Logic - Hardware Functional Specification for the Symbios Logic Series 3 Fibre Channel Disk Array Controller Model 3701 (Engelbrecht Ex 3 (LSI-1659-1733)) (CD-ROM Pathlight Exhibits D074).				
	C120	Report of the Working Group on Storage I/O for Large Scale Computing; Department of Computer Science Duke University: CS-1996-21 (PTI 173330-347). (CD-ROM Pathlight Exhibits D098).				
	C121	Brian Allison's 1999 Third Quarter Sales Plan (PDX 38) CNS 022120-132)) (CD-ROM Pathlight Exhibits D201).			6/5/2001	
	C122	Brooklyn SCSI-SCSI Intelligent External RAID Bridge Definition Phase External Documentation (CD-ROM Pathlight Exhibits D129).				
	Examiner Signature				Date Considered	

DFW

IN THE UNITED STATES PATENT AND TRADEMARK OFFICE	
TERMINAL DISCLAIMER TO OBIVIATE A DOUBLE PATENTING REJECTION OVER A PRIOR PATENT	
Atty. Docket No. CROSS1120-13	
Applicant Geoffrey B. Hoese, et al.	
Application Number 10/658,163	Date Filed 09/09/2003
Title Storage Router and Method for Providing Virtual Local Storage	
Group Art Unit 2182	Examiner Shin, Christopher B.
Confirmation Number: 5675	



Commissioner for Patents
P.O. Box 1450
Alexandria, VA 22313-1450

Dear Sir:

Certificate of Mailing Under 37 C.F.R. §1.8
I hereby certify that this correspondence is being deposited with the U.S. Postal Service as First Class Mail in an envelope addressed to: Commissioner for Patents, P.O. Box 1450, Alexandria, VA 22313 on October 28, 2005.
 Janice Pampell

Crossroads Systems, Inc., the owner of one hundred percent (100%) interest in the instant application, as evidenced by the Assignment Recorded on December 31, 1997 on Reel/Frame: 8929/0290 hereby disclaims, except as provided below, the terminal part of the statutory term of any patent granted on the instant application, which would extend beyond the expiration date of the full statutory term defined in 35 U.S.C. § 154 to 156 and 173 of U.S. Patent Nos. 5,941,972, 6,421,753, 6,425,036, 6,425,035, 6,789,152, 6,738,854, and 6,763,419. The owner hereby agrees that any patent so granted on the instant application shall be enforceable only for and during such period that it and the prior patent are commonly owned. This agreement runs with any patent granted on the instant application and is binding upon the grantee, its successors or assigns.

In making the above disclaimer, the owner does not disclaim the terminal part of any patent granted on the instant application that would extend to the expiration date of the full statutory term as defined in 35 U.S.C. § 154 to 156 and 173 of the prior patent, as presently shortened by any terminal disclaimer, in the event that it later expires for failure to pay a

maintenance fee, is held unenforceable, is found invalid by a court of competent jurisdiction, is statutorily disclaimed in whole or terminally disclaimed under 37 C.F.R. 1.321, has all claims canceled by a reexamination certificate, is reissued, or is in any manner terminated prior to the expiration of its full statutory term as presently shortened by any terminal disclaimer.

Check box 1, 2, 3, or 4 as appropriate.

1. For submission on behalf of an organization (e.g., corporation, partnership, university, government agency, etc.), the undersigned is empowered to act on behalf of the organization.

I hereby declare that all statements made herein of my own knowledge are true and that all statements made on information and belief are believed to be true; and further that these statements were made with the knowledge that willful false statements and the like so made are punishable by fine or imprisonment, or both, under Section 1001 of Title 18 of the United States Code and that such willful false statements may jeopardize the validity of the application or any patent issued thereon.

* Statement under 37 C.F.R. 3.73(b) is required if terminal disclaimer is signed by the assignee (owner). Form PTO/SB/96 may be used for making this certification. See MPEP § 324.

2. The undersigned is an attorney or agent of record.
3. Terminal disclaimer fee under 37 C.F.R. 1.20(d) included.
4. The Commissioner is hereby authorized to deduct any deficiencies or credit any overpayments regarding this application from deposit account 50-3183 of Sprinkle IP Law Group.



Steven Sprinkle

10/28/05
Dated

Please forward to Group Art Unit 2182

Amended Compact Discs

EXAMINER NOTE: THIS PAPER IS AN INTERNAL WORKSHEET ONLY. DO NOT ENCLOSE WITH ANY COMMUNICATION TO THE APPLICANT. ITS PURPOSE IS ONLY THAT OF AN AID IN HIGHLIGHTING A PARTICULAR PROBLEM IN A COMPACT DISC.

THE ATTACHED CD (COPY 1) HAS BEEN REVIEWED BY OIPE FOR COMPLIANCE WITH 37 CFR 1.52(E). **Please match this CD with the application listed below.**

Date: 8/16/2005
Serial No./Control No. 101658163
Reviewed By: K. SMITH Phone: 3089210 ext. 118

- The compact discs are readable and acceptable.
- Copy 1 and Copy 2 of the compact discs are not the same.
- The compact discs are unreadable.
- The files on the compact discs are not in ASCII.
- The compact discs contain at least one virus.
- Other NOT PROPER SUBJECT MATTER FOR CD



UNITED STATES PATENT AND TRADEMARK OFFICE

UNITED STATES DEPARTMENT OF COMMERCE
United States Patent and Trademark Office
Address: COMMISSIONER FOR PATENTS
P.O. Box 1450
Alexandria, Virginia 22313-1450
www.uspto.gov

APPLICATION NUMBER	FILING OR 371 (c) DATE	FIRST NAMED APPLICANT	ATTY. DOCKET NO./TITLE
10/658,163	09/09/2003	Geoffrey B. Hoesle	CROSS1120-13

CONFIRMATION NO. 5675

25094
DLA PIPER RUDNICK GRAY CARY US, LLP
2000 University Avenue
E. Palo Alto, CA 94303-2248



OC000000016767235

Date Mailed: 08/12/2005

NOTICE REGARDING POWER OF ATTORNEY

This is in response to the Power of Attorney filed 07/26/2005 . The Power of Attorney in this application is not accepted for the reason(s) listed below:

- The Power of Attorney is from an assignee and the Certificate required by 37 CFR 3.73(b) has not been received.



 BERHANU-GIRUM
 PTOSS (703) 305-0677

OFFICE COPY

10/658163

PATENT APPLICATION FEE DETERMINATION RECORD
Effective January 1, 2003

Application or Docket Number
~~2008103~~

CLAIMS AS FILED - PART I

	(Column 1)	(Column 2)
TOTAL CLAIMS	35	
FOR	NUMBER FILED	NUMBER EXTRA
TOTAL CHARGEABLE CLAIMS	39 minus 20 =	* 19
INDEPENDENT CLAIMS	7 minus 3 =	* 4
MULTIPLE DEPENDENT CLAIM PRESENT <input type="checkbox"/>		

* If the difference in column 1 is less than zero, enter "0" in column 2

SMALL ENTITY TYPE OR OTHER THAN SMALL ENTITY

RATE	FEE	OR	RATE	FEE
BASIC FEE	375.00	OR	BASIC FEE	750.00
X\$ 9=	12	OR	X\$18=	
X42=	18	OR	X84=	
+140=		OR	+280=	
TOTAL	214	OR	TOTAL	

CLAIMS AS AMENDED - PART II

	(Column 1)	(Column 2)	(Column 3)
AMENDMENT A	CLAIMS REMAINING AFTER AMENDMENT	HIGHEST NUMBER PREVIOUSLY PAID FOR	PRESENT EXTRA
	Total	* 34 Minus ** 39	=
	Independent	* 7 Minus *** 7	=
FIRST PRESENTATION OF MULTIPLE DEPENDENT CLAIM <input type="checkbox"/>			

SMALL ENTITY OR OTHER THAN SMALL ENTITY

RATE	ADDITIONAL FEE	OR	RATE	ADDITIONAL FEE
X\$ 9=		OR	X\$18=	
X42=		OR	X84=	
+140=		OR	+280=	
TOTAL ADDIT. FEE		OR	TOTAL ADDIT. FEE	

	(Column 1)	(Column 2)	(Column 3)
AMENDMENT B	CLAIMS REMAINING AFTER AMENDMENT	HIGHEST NUMBER PREVIOUSLY PAID FOR	PRESENT EXTRA
	Total	* Minus **	=
	Independent	* Minus ***	=
FIRST PRESENTATION OF MULTIPLE DEPENDENT CLAIM <input type="checkbox"/>			

RATE	ADDITIONAL FEE	OR	RATE	ADDITIONAL FEE
X\$ 9=		OR	X\$18=	
X42=		OR	X84=	
+140=		OR	+280=	
TOTAL ADDIT. FEE		OR	TOTAL ADDIT. FEE	

	(Column 1)	(Column 2)	(Column 3)
AMENDMENT C	CLAIMS REMAINING AFTER AMENDMENT	HIGHEST NUMBER PREVIOUSLY PAID FOR	PRESENT EXTRA
	Total	* Minus **	=
	Independent	* Minus ***	=
FIRST PRESENTATION OF MULTIPLE DEPENDENT CLAIM <input type="checkbox"/>			

RATE	ADDITIONAL FEE	OR	RATE	ADDITIONAL FEE
X\$ 9=		OR	X\$18=	
X42=		OR	X84=	
+140=		OR	+280=	
TOTAL ADDIT. FEE		OR	TOTAL ADDIT. FEE	

* If the entry in column 1 is less than the entry in column 2, write "0" in column 3.
 ** If the "Highest Number Previously Paid For" IN THIS SPACE is less than 20, enter "20."
 *** If the "Highest Number Previously Paid For" IN THIS SPACE is less than 3, enter "3."
 The "Highest Number Previously Paid For" (Total or Independent) is the highest number found in the appropriate box in column 1.

BEST AVAILABLE COPY

IN THE UNITED STATES PATENT AND TRADEMARK OFFICE

REPLY TO OFFICE ACTION DATED 01/27/2005

Atty. Docket No.
CROSS1120-13



Applicant Geoffrey B. Hoese	
Application Number 10/658,163	Date Filed 09/09/2003
Title Storage Router and Method for Providing Virtual Local Storage	
Group Art Unit 2182	Examiner Shin, Christopher B.
Confirmation Number: 5675	

Commissioner for Patents
P.O. Box 1450
Alexandria, VA 22313-1450

Dear Sir:

<p><u>Certificate of Mailing Under 37 C.F.R. §1.10</u></p> <p>I hereby certify that this correspondence is being deposited with the United States Postal Service as Express Mail to Addressee (Label No. EV704312847US) addressed to Commissioner for Patents, P.O. Box 1450, Alexandria, VA 22312-1450 on <u>7-29-05</u>.</p> <p align="center"><i>Julie H. Blackard</i> _____ Signature</p> <p align="center">Julie H. Blackard _____ Printed Name</p>

In response to the Official Action mailed January 27, 2005, Applicant respectfully requests the Examiner reconsider the rejections of the Claims in view of the this reply.

IN THE ABSTRACT:

Please amend the abstract as follows:

A storage router (56) and storage network (50) provide virtual local storage on remote SCSI storage devices (60, 62, 64) to Fiber Channel devices. A plurality of Fiber Channel devices, such as workstations (58), are connected to a Fiber Channel transport medium (52), and a plurality of SCSI storage devices (60, 62, 64) are connected to a SCSI bus second Fibre Channel transport medium (54). The storage router (56) interfaces between the Fiber Channel transport media medium (52) and the SCSI bus transport medium (54). The storage router (56) maps between the workstations (58) and the SCSI storage devices (60, 62, 64) and implements access controls for storage space on the SCSI storage devices (60, 62, 64). The storage router (56) then allows access from the workstations (58) to the SCSI storage devices (60, 62, 64) using native low level, block protocol in accordance with the mapping and the access controls.

IN THE CLAIMS:

Please amend the claims as follows. The claims are in the format as required by 35 C.F.R. § 1.121.

1-14 Cancelled

15. (Previously Presented) A storage router for providing virtual local storage on remote storage devices to a device, comprising:

- a buffer providing memory work space for the storage router;
- a first Fibre Channel controller operable to connect to and interface with a first Fibre Channel transport medium;
- a second Fibre Channel controller operable to connect to and interface with a second Fibre Channel transport medium; and
- a supervisor unit coupled to the first and second Fibre Channel controllers and the buffer, the supervisor unit operable:
 - to maintain a configuration for remote storage devices connected to the second Fibre Channel transport medium that maps between the device and the remote storage devices and that implements access controls for storage space on the remote storage devices; and
 - to process data in the buffer to interface between the first Fibre Channel controller and the second Fibre Channel controller to allow access from Fibre Channel initiator devices to the remote storage devices using native low level, block protocol in accordance with the configuration.

16. (Previously Presented) The storage router of claim 15, wherein the configuration maintained by the supervisor unit includes an allocation of subsets of storage space to associated Fibre Channel devices, wherein each subset is only accessible by the associated Fibre Channel device.

17. (Previously Presented) The storage router of claim 16, wherein the Fibre Channel devices comprise workstations.

18. (Previously Presented) The storage router of claim 16, wherein the remote storage devices comprise hard disk drives.

19. (Previously Presented) The storage router of claim 15, wherein each of the first Fibre Channel controller comprises:

- a Fibre Channel (FC) protocol unit operable to connect to the Fibre Channel transport medium;

- a first-in-first-out queue coupled to the Fibre Channel protocol unit; and

- a direct memory access (DMA) interface coupled to the first-in-first-out queue and to the buffer.

20. (Previously Presented) A storage network, comprising:

- a first Fibre Channel transport medium;

- a second Fibre Channel transport medium;

- a plurality of workstations connected to the first Fibre Channel transport medium;

- a plurality of storage devices connected to the second Fibre Channel transport medium;

and

- a storage router interfacing between the first Fibre Channel transport medium and the second Fibre Channel transport medium, the storage router providing virtual local storage on the storage devices to the workstations and operable:

- to map between the workstations and the storage devices;

- to implement access controls for storage space on the storage devices; and

- to allow access from the workstations to the storage devices using native low level, block protocol in accordance with the mapping and access controls.

21. (Previously Presented) The storage network of claim 20, wherein the access controls include an allocation of subsets of storage space to associated workstations, wherein each subset is only accessible by the associated workstation.

22. (Previously Presented) The storage network of claim 20, wherein the storage devices comprise hard disk drives.

23. (Previously Presented) The storage network of claim 20, wherein the storage router comprises:

a buffer providing memory work space for the storage router;

a first Fibre Channel controller operable to connect to and interface with the first Fibre Channel transport medium, the first Fibre Channel controller further operable to pull outgoing data from the buffer and to place incoming data into the buffer;

a second Fibre Channel controller operable to connect to and interface with the second Fibre Channel transport medium, the second Fibre Channel controller further operable to pull outgoing data from the buffer and to place incoming data into the buffer; and

a supervisor unit coupled to the first and second Fibre Channel controllers and the buffer, the supervisor unit operable:

to maintain a configuration for the storage devices that maps between workstations and storage devices and that implements the access controls for storage space on the storage devices; and

to process data in the buffer to interface between the first Fibre Channel controller and the second Fibre Channel controller to allow access from workstations to storage devices in accordance with the configuration.

24. (Previously Presented) A method for providing virtual local storage on remote storage devices to Fibre Channel devices, comprising:

interfacing with a first Fibre Channel transport medium;

interfacing with a second Fibre Channel transport medium;

maintaining a configuration for remote storage devices connected to the second Fibre Channel transport medium that maps between Fibre Channel devices and the remote storage devices and that implements access controls for storage space on the remote storage devices; and

allowing access from Fibre Channel initiator devices to the remote storage devices using native low level, block protocol in accordance with the configuration.

25. (Previously Presented) The method of claim 24, wherein maintaining the configuration includes allocating subsets of storage space to associated Fibre Channel devices, wherein each subset is only accessible by the associated Fibre Channel device.

26. (Previously Presented) The method of claim 25, wherein the Fibre Channel devices comprise workstations.

27. (Previously Presented) The method of claim 25, wherein the remote storage devices comprise hard disk drives.

28. (Previously Presented) An apparatus for providing virtual local storage on a remote storage device to a device operating according to a Fibre Channel protocol, comprising:
a first controller operable to connect to and interface with a first transport medium, wherein the first transport medium is operable according to the Fibre Channel protocol;
a second controller operable to connect to and interface with a second transport medium, wherein the second transport medium is operable according to the Fibre Channel protocol; and
a supervisor unit coupled to the first controller and the second controller, the supervisor unit operable to control access from the device connected to the first transport medium to the remote storage device connected to the second transport medium using native low level, block protocols according to a map between the device and the remote storage device.

29. (Previously Presented) The apparatus of Claim 28, wherein the supervisor unit is further operable to maintain a configuration wherein the configuration includes the map between the device and the remote storage device, and further wherein the map includes virtual LUNs that provide a representation of the storage device.

30. (Previously Presented) The apparatus of Claim 29, wherein the map only exposes the device to LUNs that the device may access.

31. (Previously Presented) The apparatus of Claim 28, wherein the supervisor unit is further operable to maintain a configuration including the map, wherein the map provides a mapping from a host device ID to a virtual LUN representation of the remote storage device to a physical LUN of the remote storage device.

32. (Previously Presented) The apparatus of Claim 28, wherein the remote storage device further comprises storage space partitioned into virtual local storage for the device connected to the first transport medium.

33. (Previously Presented) The apparatus of Claim 32, wherein the supervisor unit is further operable to prevent the device from accessing any storage on the remote storage device that is not part of a virtual local storage partition assigned to the device

34. (Previously Presented) The apparatus of Claim 28, wherein the first controller and the second controller further comprise a single controller.

35. (Previously Presented) A system for providing virtual local storage on remote storage devices, comprising:

a first controller operable to connect to and interface with a first transport medium operable according to a Fibre Channel protocol;

a second controller operable to connect to and interface with a second transport medium operable according to the Fibre Channel protocol;

at least one device connected to the first transport medium;

at least one storage device connected to the second transport medium; and

an access control device coupled to the first controller and the second controller, the access control device operable to:

map between the at least one device and a storage space on the at least one storage device; and

control access from the at least one device to the at least one storage device using native low level, block protocol in accordance with the map.

36. (Previously Presented) The system of Claim 35, wherein the access control device is further operable to maintain a configuration wherein the configuration includes the map between the at least one device and the at least one storage device, and further wherein the map includes virtual LUNs that provide a representation of the at least one storage device.

37. (Previously Presented) The system of Claim 36, wherein the map only exposes the at least one device to LUNs that the at least one device may access.

38. (Previously Presented) The system of Claim 35, wherein the access control device is further operable to maintain a configuration including the map, wherein the map provides a mapping from a host device ID to a virtual LUN representation of the at least one storage device to a physical LUN of the at least one storage device.

39. (Previously Presented) The system of Claim 35, wherein the at least one storage device further comprises storage space partitioned into virtual local storage for the at least one device.

40. (Previously Presented) The system of Claim 39, wherein the access control unit is further operable to prevent at least one device from accessing any storage on the at least one storage device that is not part of a virtual local storage partition assigned to the at least one device.

41. (Previously Presented) The system of Claim 35, wherein the first controller and the second controller further comprise a single controller.

42. (Previously Presented) A method for providing virtual local storage on remote storage devices, comprising:

mapping between a device connected to a first transport medium and a storage device connected to a second transport medium, wherein the first transport medium and the second transport medium operate according to a Fibre Channel protocol;

implementing access controls for storage space on the storage device; and

allowing access from the device connected to the first transport medium to the storage device using native low level, block protocols.

43. (Previously Presented) The method of Claim 42, further comprising maintaining a configuration wherein the configuration includes a map between the device and the one storage

device, and further wherein the map includes virtual LUNs that provide a representation of the storage device.

44. (Previously Presented) The method of Claim 43, wherein the map only exposes the device to LUNs that the device may access.

45. (Previously Presented) The method of Claim 42, further comprising maintaining a configuration including a map from a host device ID to a virtual LUN representation of the storage device to a physical LUN of the storage device.

46. (Previously Presented) The method of Claim 42, further comprising partitioning storage space on the storage device into virtual local storage for the device.

47. (Previously Presented) The method of Claim 46, further comprising preventing the device from accessing any storage on the storage device that is not part of a virtual local storage partition assigned to the device.

48. (Previously Presented) A system for providing virtual local storage, comprising:
a host device;
a storage device remote from the host device, wherein the storage device has a storage space;
a first controller;
a second controller
a first transport medium operable according to a Fibre Channel protocol, wherein the first transport medium connects the host device to the first controller;
a second transport medium operable according to the Fibre Channel protocol, wherein the second transport medium connects the second controller to the storage device;
a supervisor unit coupled to the first controller and the second controller, the supervisor unit operable to:
maintain a configuration that maps between the host device and at least a portion of the storage space on the storage device; and

implement access controls according to the configuration for the storage space on the storage device using native low level, block protocol.

49. (Previously Presented) The system of Claim 48, wherein the supervisor unit is further operable to:

maintain a configuration that maps from the host device to a virtual representation of at least a portion of the storage space on the storage device to the storage device; and

allow the host device to access only that portion of the storage space that is contained in the map.

50. (Previously Presented) The system of Claim 49, wherein the configuration comprises a map from a host device ID to a virtual LUN representation of the storage device to a physical LUN of the storage device.

51. (Previously Presented) The system of Claim 48, wherein the storage device further comprises storage space partitioned into virtual local storage for the host device.

52. (Previously Presented) The system of Claim 51, wherein the supervisor unit is further operable to prevent the host device from accessing any storage on the storage device that is not part of a virtual local storage partition assigned to the host device.

53. (Previously Presented) The apparatus of Claim 48, wherein the first controller and the second controller further comprise a single controller.

REMARKS

The Examiner requested that the Applicants clarify several terms in the claims and point out support for a system with two Fibre Channel transport media. Applicants appreciate the Examiner's efforts to expedite prosecution and address the Examiner's request for particular definitions and showings of support in the remarks provided below.

I. Objections to Drawings

The drawings stand objected to as failing to comply with 37 C.F.R. § 1.83(a) as not showing every feature of the invention specified in the claims because they do not show the claimed limitation regarding the first and second media being a Fibre Channel protocol type. Applicants note, however, that such a drawing is only required "where necessary for the understanding of the subject matter sought to be patented." As discussed in more detail below, the Specification discloses an implementation in which the initiator is a Fibre Channel initiator, the target is a Fibre Channel target. See Specification at page 15, lines 12-17. Specifically, the Specification states that the "storage router has various modes of operation that are possible between FC and SCSI target and initiator combinations. These modes are: FC Initiator to SCSI Target; SCSI Initiator to FC Target; SCSI Initiator to SCSI Target; **and FC Initiator to FC Target.**" *Id.* (emphasis added). The figures provided in the invention, along with the Specification, provide additional information relating to the invention in detail necessary to support this FC initiator to FC target embodiment. One of skill in the art would not require an additional drawing to understand that a workstation (or other initiator) can be connected to the storage router via Fibre Channel and a storage device (or other target) can be connected to the storage router via Fibre Channel. Therefore, Applicants submit that such a drawing showing a storage router connected to two Fibre Channel transport mediums is not necessary for an understanding of the invention and not required under 37 C.F.R. § 1.83(a). Accordingly, withdrawal of this rejection is respectfully requested.

II. Objection to Specification

The Examiner also objected to the Abstract and the Specification. Applicants have amended the Abstract to describe that the two transport media are Fibre Channel.

Furthermore, the Specification specifically discloses a Fibre Channel Initiator-to-Fibre Channel target mode at page 15, lines 12-17:

The storage router has various modes of operation that are possible between FC and SCSI target and initiator combinations. These modes are: FC Initiator to SCSI Target; SCSI Initiator to FC Target; SCSI Initiator to SCSI Target; **and FC Initiator to FC Target.** (Emphasis Added).

Thus, the Specification specifically recites that one embodiment of the invention is a FC initiator device and a FC target storage device. This FC initiator to FC storage device embodiment is entirely consistent with the recitations in claims 15-53.

In fact, the Specification goes further and discloses two additional particular embodiment of the Fibre Channel Initiator-to-Fibre Channel target mode at page 15, lines 17-25:

The first two modes can be supported concurrently in a single storage router device are discussed briefly below. The third mode can involve two storage router devices back to back and can serve primarily as a device to extend the physical distance beyond that possible via a direct SCSI connection. **The last [FC Initiator to FC Target] mode can be used to carry FC protocols encapsulated on other transmission technologies (e.g. ATM, SONET), or to act as a bridge between two FC loops (e.g. as a two port fabric).** (Emphasis Added).

This description clearly shows that the last mode (the FC initiator to FC target mode where both the transport medium to which a host is connected and the transport medium to which the storage device is connected is a Fibre Channel transport medium) can done in a variety of ways, including the examples recited where (1) the FC protocols are carried on other transmission technologies and (2) the storage router acts as a bridge between two FC loops. The Specification therefore discloses an invention that includes a FC initiator to FC target embodiment, along with two distinct examples of that embodiment. Therefore, Applicants respectfully request withdrawal of this objection.

III. Claim Term Definitions

The Examiner also requested the Applicant provide definitions for several claim terms. As the Examiner is aware, the claims in US Patent No. 5, 941, 972 have been interpreted by

the U.S. Federal District Court in the case *Crossroads v. Chaparral Network Storage, Inc.*, Western District of Texas, Civil Action No. A-00-CA-217-SS and *Crossroads Systems (Texas), Inc., v. Pathlight Technology, Inc.*, Western District of Texas, Civil Action No. A-00CA-248-JN (collectively, the "Chaparral Litigation"). In that case, the Federal District Court issued a Joint Markman Order (the "Markman Order") interpreting the terms "native, low level block protocol" and "map". Applicant will rely on both the Specification and this Markman Order in response to the Examiner's request to define these terms.

A. Native Low Level Block Protocol ("NLLBP")

The term "native low level block protocol" (or "NLLBP") is a protocol that enables computers to exchange information that does not involve the overhead of high level protocols and file systems typically required by network servers. This definition is supported in the Specification and prior litigation interpreting this claim term.

According to the invention, the host computers connected to the first transport medium are allowed to access the remote storage devices using a NLLBP. In systems prior to the present invention, when making a request to storage through a network server to allow access between workstations and remote storage devices, a workstation typically had to translate the requests from its file system protocols to higher level network protocols in order to communicate with the network server, and the network server would then translate them into low level requests to the storage device(s). In contrast, as described in the Specification, allowing a host to access storage devices using a NLLBP provides a mechanism by which communication between the host and the storage devices can be accomplished faster because there is no need to translate from a network protocol to a NLLBP. See Specification, page 2, line 17-page 3, line 13; page 7, line 17-26 (distinguishing an NLLBP from higher-level protocols by contrasting the present invention (allowing access using NLLBP) to prior art solutions (which allowed access using network protocols requiring translation to NLLBP)). Thus, the Specification points out that a native low level block protocol is one that does not involve the overhead of high level protocols used by network servers.

Furthermore, in the Chaparral Litigation the Federal District Court issued its Markman Order defining the term "NLLBP" as follows: "a set of rules or standards that enable computers to exchange information and do not involve the overhead of high level protocols and file systems typically required by network servers." A copy of the Markman Order is attached

hereto as Exhibit A. This construction and the validity of the '972 Patent was upheld by the Federal Circuit. A copy of the Federal Circuit decision affirming the decision of the lower court is attached hereto as Exhibit B. Thus, based on both the Specification and the Markman Order, an NLLBP is a protocol that enables computers to exchange of information without the overhead of high-level protocols and file systems typically required by network servers.

B. Mapping

The term "mapping" means to create a path from a host device on one side of the storage router to a device on the other side of the router where a map contains a representation of the devices on each side of the storage router, so that when a device on one side of the storage router wants to communicate to a device on the other side of the storage router, the storage router can connect the devices. This definition is supported by the Specification and prior litigation interpreting this claim term.

Mapping between devices connected to the first transport medium and storage devices in the present application refers to a mapping between the workstations/host computers and storage devices such that a particular workstation/host computer on the first transport medium is associated with a storage device, storage devices or portion thereof on the second transport medium. As discussed in the Specification, the mapping provides a correlation between devices on the first data transport medium and the storage devices through one or more steps, and can, for example, be implementing through the use of mapping tables. See, Specification, page 4, lines 15-21; page 4, line 28-page 5, line 6; page 9, lines 7-8, page 10, lines 4-7 and page 22, lines 8-11. Thus, the Specification points out that mapping provides a correlation between a host device and a storage device so as to create a path the storage router can use to connect the host device to the storage device.

Additionally, the Federal District Court in the Chaparral Litigation defined the term "map" in its Markman Order as follows: "to create a path from a device on one side of the storage router to a device on the other side of the router, i.e., from a Fibre Channel device to a SCSI device (or vice-versa). A map contains a representation of devices on each side of the storage router, so that when a device on one side of the storage router wants to communicate to a device on the other side of the storage router, the storage router can connect the devices." See, Markman Order, Exhibit A, page 12. Thus, the mapping of the present invention associates a representation of the host device(s) on the first transport medium with a

representation of the storage devices on the second transport medium to create a path between the hosts and the remote storage devices (or portion(s) thereof).

C. Support for Fibre Channel-to-Fibre Channel Implementation

As discussed above, the Specification discloses a Fibre Channel Initiator-to-Fibre Channel target mode. See, Specification, page 15, lines 12-25.

The storage router has various modes of operation that are possible between FC and SCSI target and initiator combinations. These modes are: FC Initiator to SCSI Target; SCSI Initiator to FC Target; SCSI Initiator to SCSI Target; **and FC Initiator to FC Target.** (Emphasis Added). The first two modes can be supported concurrently in a single storage router device are discussed briefly below. The third mode can involve two storage router devices back to back and can serve primarily as a device to extend the physical distance beyond that possible via a direct SCSI connection. **The last [FC Initiator to FC Target] mode can be used to carry FC protocols encapsulated on other transmission technologies (e.g. ATM, SONET), or to act as a bridge between two FC loops (e.g. as a two port fabric).** (Emphasis Added).

Thus, the Specification specifically recites that one embodiment of the invention is a FC initiator device and a FC target storage device. This FC initiator to FC storage device embodiment is entirely consistent with the recitations in claims 15-53.

IV. Rejections Under 35 U.S.C. §112

The Examiner rejected Claim 15-53 under 35 U.S.C. §112, first paragraph, because the Examiner asserts that i) the best mode contemplated by the inventor has not been disclosed and ii) the disclosure does not meet the enablement requirement. The basis for these rejections asserted by the Examiner is that the "disclosure does not clearly disclose any details of the present claims regarding the first and second media being both Fibre Channel transport as a whole."

As previously discussed, Applicants respectfully submit that an implementation having both a first Fibre Channel transport and a second Fibre Channel transport is disclosed at page 15, lines 12-25, as discussed above. This FC initiator to FC target mode represents one embodiment of the invention generally described in the remainder of the Specification and the Drawings. In addition, the Applicants went further and discussed two additional example implementations of this FC initiator to FC target mode embodiment: in one example

implementation, the Fibre Channel protocols can be encapsulated on other transmission technologies (e.g., ATM, SONET); in the other example implementation, the storage router acts as a bridge between two Fibre Channel loops (i.e., a first fibre channel transport medium and a second fibre channel transport medium). Contrary to the Examiner's assertion, Applicants respectfully submit that there is no evidence that the inventors concealed the best mode of connecting fibre channel transport media.

The Specification further provides support for implementing the configuration, mapping and access controls for Fibre Channel devices so as to enable one of ordinary skill in the art to practice the FC initiator to FC storage device embodiment of the invention. As one example, the Specification discusses the particulars of Fibre Channel devices, specifically stating:

Fibre Channel devices within a fabric are addressed by a unique port identifier. This identifier is assigned to a port during certain well-defined states of the FC protocol. Individual ports are allowed to arbitrate for a known, user defined address. If such an address is not provided, or if arbitration for a particular user address fails, the port is assigned a unique address by the FC protocol. This address is generally not guaranteed to be unique between instances. Various scenarios exist where the AL-PA of a device will change, either after power cycle or loop reconfiguration.

The FC protocol also provides a logical unit address field within command structures to provide addressing to devices internal to a port. The FCP CMD payload specifies an eight byte LUN field. Subsequent identification of the exchange between devices is provided by the FQXID (Fully Qualified Exchange ID). See, Specification, page 19, lines 9-25.

Thus, the Applicants described these addressing conventions in a manner that would enable one of ordinary skill in the art to implement them for Fibre Channel devices.

As another example relating to mapping, the Specification states that "mapping can be implemented through the use of mapping table or other mapping techniques." See, Specification, page 9, lines 7-8; page 10, lines 4-7. Based on the disclosed Fibre Channel addressing techniques, one of ordinary skill in the art would understand how to implement a table that maps Fibre Channel initiators to Fibre Channel storage devices or portions thereof. In yet another example, the Specification provides that access controls limit a computers access to specified storage devices or portions thereof. See, Specification, page 10, lines 20-24. The storage router can use tables to map, for each initiator, what storage access is

available and what partition is being addressed by a particular request. See, Specification page 22, lines 8-11. Based on the Fibre Channel addressing scheme, those in the art would understand how to use tables to map Fibre Channel initiators to Fibre Channel targets to control access by the Fibre Channel targets to assigned storage devices or portions thereof. Thus, in the Fibre Channel Initiator-to-Fibre Channel target embodiment, one of ordinary skill in the art would understand how to provide tables that map a representation of a Fibre Channel initiator device to a representation of a Fibre Channel target device and that cause requests from particular Fibre Channel Initiators to be directed (or not allowed to be directed) to particular storage.

The present application thus discloses i) a Fibre Channel initiator-to-Fibre Channel target mode of operation, ii) mapping achieved through, for example, tables and iii) access controls are implemented through mapping in an enabling manner. There is simply no evidence that the inventors concealed some better way of practicing the present invention. Based on the Specification, one of ordinary skill in the art would understand how to provide tables that map Fibre Channel initiator devices to a Fibre Channel target devices and that cause certain requests from a Fibre Channel Initiator to be directed to permitted storage, thus allowing the use of NLLBP from the Fibre Channel Initiator to the storage router and from the storage router to the Fibre Channel target. Applicants therefore respectfully request withdrawal of the Claim rejections.

V. Double Patenting Rejections

Claims 15-53 stand rejected under the judicially created doctrine of obviousness-type double patenting as being unpatentable over claims 1-14 of U.S. Patent No. 5,941,972. Applicants are including with this reply a timely filed terminal disclaimer in compliance with 37 C.F.R. § 1.321(c). U.S. Patent No. 5,941,972 and the current Application are commonly owned. Accordingly, withdrawal of this rejection is respectfully requested.

Claims 15-53 stand rejected under the judicially created doctrine of obviousness-type double patenting as being unpatentable over claims 1-14 of U.S. Patent No. 6,425,035. Applicants are including with this reply a timely filed terminal disclaimer in compliance with 37 C.F.R. § 1.321(c). U.S. Patent No. 6,425,035 and the current Application are commonly owned. Accordingly, withdrawal of this rejection is respectfully requested.

Claims 15-53 stand rejected under the judicially created doctrine of obviousness-type double patenting as being unpatentable over claims 1-23 of U.S. Patent No. 6,738,854. Applicants are including with this reply a timely filed terminal disclaimer in compliance with 37 C.F.R. § 1.321(c). U.S. Patent No. 6,738,854 and the current Application are commonly owned. Accordingly, withdrawal of this rejection is respectfully requested.

Claims 15-53 stand rejected under the judicially created doctrine of obviousness-type double patenting as being unpatentable over claims 1-10 of U.S. Patent No. 6,763,419. Applicants are including with this reply a timely filed terminal disclaimer in compliance with 37 C.F.R. § 1.321(c). U.S. Patent No. 6,425,035 and the current Application are commonly owned. Accordingly, withdrawal of this rejection is respectfully requested.

VI. Conclusion

Applicants have now made an earnest attempt to place this case in condition for allowance. Other than as explicitly set forth above, this reply does not include acquiescence to statements, assertions, assumptions, conclusions, or any combination thereof in the Office Action. For the foregoing reasons and for other reasons clearly apparent, Applicant respectfully requests full allowance of the pending claims. The Examiner is invited to telephone the undersigned at the number listed below for prompt action in the event any issues remain.

An extension of three (3) months is requested and a Notification of Extension of Time Under 37 C.F.R. § 1.136 with the appropriate fee is enclosed herewith.

The Director of the U.S. Patent and Trademark Office is hereby authorized to charge any fees or credit any overpayments to Deposit Account No. 50-3183 of Sprinkle IP Law Group.

Respectfully submitted,

Sprinkle IP Law Group
Attorneys for Applicant

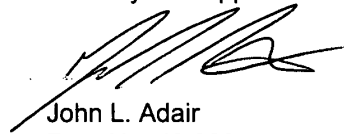

John L. Adair
Reg. No. 48,828

Date: July 27, 2005

1301 W. 25th Street, Suite 408
Austin, TX 78705
Tel. (512) 637-9223
Fax. (512) 371-9088

Exhibit A

BEST AVAILABLE COPY

UNITED STATES DISTRICT COURT
WESTERN DISTRICT OF TEXAS
AUSTIN DIVISION

FILED

JUL 27 2000

U. S. DISTRICT COURT
BY CLERK'S OFFICE
DEPUTY

CROSSROADS SYSTEMS, (TEXAS), INC. §

vs. §

CHAPARRAL NETWORK §
STORAGE, INC. §

NO. A 00 CA 217 SS

CROSSROADS SYSTEMS, (TEXAS), INC. §

vs. §

PATHLIGHT TECHNOLOGY, INC. §

NO. A 00 CA 248 SS

ORDER

BE IT REMEMBERED that on the 25th day of July 2000 the Court, in accordance with *Markman v. Westview Instruments, Inc.*, 52 F.3d 967 (Fed. Cir. 1995), *aff'd*, 116 S. Ct. 1384 (1996), held a hearing at which the parties appeared by representation of counsel and made oral arguments on their proposed claims construction. At the hearing, the parties presented a Joint Stipulation of Claim Construction, indicating that the parties have agreed upon the definitions for seventeen terms and/or phrases in U.S. Patent No. 5,941,972 ("the '972 patent"), and that only ten terms and/or phrases in the '972 patent remain in dispute. After considering the briefs, the case file as a whole, and the applicable law, the Court enters the following opinion and order.

I. Standard for Claims Construction

The construction of claims, or the definition of the terms used in the claims, is a matter of law for the Court. When adopting a claim construction, the Court should first consider the intrinsic evidence, which includes the claims, the specification, and the prosecution history. *See Vitronics*

27

A 00473

RECEIVED

FEB 07 2005

OFFICE OF PETITIONS

Corp. v. Conceptoronic, Inc., 90 F.3d 1576, 1582 (Fed. Cir. 1996) (explaining that intrinsic evidence is "the most significant source of the legally operative meaning of disputed claim language"). Not surprisingly, the starting point is always "the words of the claims themselves." *Id.*; see also *Comark Communications, Inc. v. Harris Corp.*, 156 F.3d 1182, 1186 (Fed. Cir. 1998). The words of the claims are generally given their ordinary and customary meaning, unless the patentee intended to use a "special definition of the term clearly stated in the patent specification or file history." *Vitronics*, 90 F.3d at 1582. Thus, the Court must review the specification and file history to determine whether the patentee intended to use any such "special" definitions. See *id.* The specification and file history may also be consulted as general guides for claim interpretation. See *Comark*, 156 F.3d at 1186.

The specification and file history, however, are not substitutes for the plain language of the claims. The specification is not meant to describe the full scope of the patent – it includes only a written description of the invention, sufficient to enable a person skilled in the art to make and use it, as well as the invention's "best mode." See 35 U.S.C. § 112. Thus, the claims may be broader than the specification, and generally should not be confined to the examples of the invention set forth in the specification. See *Comark*, 156 F.3d at 1187 ("Although the specification may aid the court in interpreting the meaning of disputed claim language, particular embodiments and examples appearing in the specification will not generally be read into the claims."). Indeed, the Federal Circuit has repeatedly emphasized that "limitations from the specification are not to be read into the claims." *Id.* at 1186.

In addition to examining the intrinsic evidence the Court may, in its discretion, receive extrinsic evidence regarding the proper construction of the patent's terms. See *Key Pharmaceuticals*

v. Hercon Labs. Corp., 161 F.3d 709, 716 (Fed. Cir. 1998) (“[T]rial courts generally can hear expert testimony for background and education on the technology implicated by the presented claim construction issues, and trial courts have broad discretion in this regard.”). The plaintiff has provided an expert affidavit and the defendant has provided excerpts from several dictionaries as extrinsic evidence concerning the construction of the terms of the ‘972 patent.

II. “implements access controls for storage space on the SCSI storage devices”

This phrase is used in claims 1, 10 and 11 of the ‘972 patent. The parties dispute whether the phrase refers to “access controls” only for certain subsections of a divided SCSI storage device, or whether it also includes limiting access to entire undivided SCSI storage devices. The plaintiff argues the phrase includes both kinds of access controls; the defendants say the phrase refers only to access controls for various subsections within a single divided SCSI storage device. The defendants also argue the plaintiff’s construction is improper because, if adopted, it will result in the ‘972 patent being invalidated by prior art.

The plaintiff proposes the following definition: “provides controls which limit a computer’s access to a specific subset of storage devices or sections of a single storage device.” See Plaintiff’s Brief, at 20. The defendants propose the phrase should be defined as “partitions the storage space on each one of the SCSI storage devices and defines the accessibility of each resulting partition.” See Defendants’ Brief, Ex. 2. The Court agrees with the plaintiff.

The intrinsic evidence of the ‘972 patent shows the plaintiff’s invention is intended to restrict access both to subsections of a SCSI storage device, as well as to entire, undivided SCSI devices. First, the plain language of this phrase refers only to “storage space” and does not limit the space

only to subsections of a divided SCSI storage device. Second, Figure 3 of the '972 patent supports a broad reading of this phrase. Figure 3 shows three SCSI storage devices, two of which are undivided (60 and 64). The third device (62) is divided into four subsections of storage space. From the simple labeling on Figure 3, it is clear that the entire, undivided storage device (64) is meant to be accessed only by a single workstation (computer E). Thus, Figure 3 expressly shows that the plaintiff's invention contemplates using "access controls" for an entire, undivided storage device as well as for the divided subsections within a single storage device.¹ Third, the language of the specification expressly describes limiting access to an entire, undivided SCSI storage device. Specifically, in referring to Figure 3, the specification states "storage device 64 can be allocated as storage for the remaining workstation 58 (workstation E)." See '972 Patent, at 4:20 - 4:21. At the hearing, the defendants' counsel argued that, simply because Figure 3 describes this feature does not mean the feature was intended to be part of the claimed invention. The Court soundly rejects this argument. Figure 3 is meant to be an example of how the plaintiff's claimed invention can be implemented, and the specification clearly describes this figure as illustrating one implementation of the claimed invention. Adopting the defendants' argument would ignore a fundamental principle of claims construction, oft repeated in the defendants' brief and oral arguments, that the specification is "the single best guide to the meaning of a disputed term." See *Vitronics*, 90 F.3d at 1582. Finally, the defendants correctly point out that the specification also refers to the single, undivided storage device (64) as a "partition (i.e., logical storage definition)." See '972 Patent, at 4:44 - 4:47. Rather than compel the defendants' proposed construction, however, this language supports the plaintiff's

¹ Figure 3 also discloses – and the defendants do not dispute – that the plaintiff's invention contemplates limiting access to various subsections of the divided SCSI storage device (62).

argument at the hearing that a discrete unit of storage – whether an entire SCSI storage device or a subsection within that device – can be referred to as a “partition.”²

The defendants also argue that, even if the intrinsic evidence supports the plaintiff’s proposed definition, this definition is nonetheless improper because it would cause the ‘972 patent to read directly upon prior art (and therefore be invalid). It is true that “claims should be read in a way that avoids ensnaring prior art if it is possible to do so.” *Harris Corp. v. IXYS Corp.*, 114 F.3d 1149, 1153 (Fed. Cir. 1997). However, the defendants have not shown that the prior art at issue – the Lui patent – would be “ensnared” by adopting the plaintiff’s definition. Importantly, the Lui patent was part of the prior art expressly considered by the patent examiner before granting the ‘972 patent. The patent examiner apparently did not use the Lui patent to reject a single claim in the ‘972 patent. The patent examiner also did not issue an Office Action requiring the plaintiff to distinguish its invention from the Lui patent on access control (or any other) grounds. Although the Patent Office is not the model of efficiency or thoroughness, its failure to cite the Lui patent as potentially invalidating prior art creates a strong presumption that the Lui patent does not read upon the plaintiff’s claimed invention. In addition, it does not appear to the Court that the Lui patent reads upon the ‘972 claimed invention. While the Lui patent does disclose a system of Fibre Channel computers and SCSI storage devices, *see* Defendants’ Brief, Ex. 6, at 2:53 - 2:65, the similarities end there. The Lui patent concerns an invention of “bypass circuits” used to “prevent the failure of any device” in the system. *See id.*, at Abstract. The invention of the Lui patent is not concerned with the swift transfer of information across a router, and thus does not disclose techniques for mapping,

² The Court expressly notes, however, that it is not defining the term “partition” in this order, as that term is not used in the ‘972 claim language.

implementing access controls, or a memory buffer.³ At the hearing, the defendants' counsel suggested that Figure 2 of the Lui patent discloses the claimed invention of the '972 patent.

However, Figure 2 of the Lui patent is not a part of the Lui invention; rather it is an illustration of a "conventional" network system that the Lui invention allegedly improves upon. *See id.* at 3:66. The Court rejects the defendants' argument that "conventional" network systems also read directly upon the '972 claimed invention. The patent examiner may have let one piece of prior art slip by; he or she would not have missed a "conventional" network system directly applicable to the plaintiff's claimed invention.

In sum, the Court will adopt the plaintiff's proposed definition and construe the phrase "implements access controls" in the claims of the '972 patent to mean "provides controls which limit a computer's access to a specific subset of storage devices or sections of a single storage device."

III. "allocation of subsets of storage space to associated Fibre Channel devices, wherein each subset is only accessible by the associated Fibre Channel device"

The dispute here is essentially the same as in the preceding section. This phrase is used in claims 2, 8 and 12 of the '972 patent. As it did with the "implements access controls . . ." phrase, the plaintiff argues the "allocation . . ." phrase means that specific Fibre Channel devices can be allocated storage space on subsections of a single SCSI storage device and on entire, undivided SCSI storage devices. The defendants stick to their general argument on this issue, and contend the phrase

³ The defendants argue these features are "implicitly" found in the Lui specification and in any event were disclosed in other prior art. *See Defendants' Brief*, at 12 and n.1. The Court is not persuaded that these features are "implicitly" disclosed by the Lui patent, and the other prior art briefly referenced by the defendants makes no mention of combining that prior art with the invention of the Lui patent, or vice-versa.

means storage space can only be allocated on subsections of a single divided SCSI storage device. Both parties agree this storage space, however it is defined, can only be accessed by the specified Fibre Channel device(s).

The plaintiff's proposed definition is "subsets of storage space are allocated to specific Fibre Channel devices." See Plaintiff's Brief, at 26. The defendants say the phrase should be defined to mean "one or more partitions that are only accessible by a single Fibre Channel device." See Defendants' Brief, Ex. 2. For the reasons discussed in the preceding section, the Court adopts the plaintiff's proposed construction.

IV. "supervisor unit"

This term is used in claims 1, 2 and 10 of the '972 patent. The plaintiff contends this term should be defined as "a microprocessor programmed to process data in a buffer in order to map between Fibre Channel devices and SCSI devices and which implements access controls." See Plaintiff's Brief, at 25. The defendants argue the term should be defined as "an Intel 80960RP processor" with several specific features. See Defendants' Brief, Ex. 2.

The defendants argue their construction is mandated by the means-plus-function analysis of § 112(6) of the Patent Act, because the claims of the '972 patent do not adequately describe the "supervisor unit" to be used. See Defendants' Brief, at 15-17. The plaintiff argues that § 112(6) does not apply because the term "means" is not used with the term "supervisor unit" and because the term "supervisor unit" is adequately described by other claim language in the '972 patent. See Plaintiff's *Markman* Exhibits, at 35-39.

Section 112(6) of the Patent Act provides that when a claim refers to the "means for" a

specific act, but fails to adequately describe these means, the means then must be defined by reference to the specification. See 35 U.S.C. § 112(6).⁴ If the claim language at issue does not include the term "means," there is a presumption that the § 112(6) means-plus-function analysis does not apply. See *Al-Site Corp. v. VSI Int'l, Inc.*, 174 F.3d 1308, 1318 (Fed. Cir. 1999) ("[W]hen an element of a claim does not use the term 'means,' treatment as a means-plus-function claim element is generally not appropriate."). To overcome this presumption, the party seeking to apply § 112(6) must show the claim language at issue is purely functional and that other claim language does not adequately describe the disputed term. See *id.* ("[W]hen it is apparent that the element invokes purely functional terms, without the additional recital of specific structure or material for performing that function, the claim element may be a means-plus-function element despite the lack of express means-plus-function language."). From a review of the claim language as a whole, the Court agrees with the plaintiff that the term "supervisor unit" is not purely functional, but refers instead to a device that can perform the tasks specifically listed in the claim language of the '972 patent. Specifically, claims 1, 2 and 10 of the '972 patent describe a "supervisor unit" that can: (1) maintain and map the configuration of networked Fibre Channel and SCSI storage devices; (2) include in this configuration an allocation of specific storage space to specific Fibre Channel devices; (3) implement access controls for the SCSI storage devices; and (4) process data in the storage router's buffer to allow an exchange between the Fibre Channel and SCSI storage devices. See '972 Patent,

⁴ Section 112(6) reads as follows: "An element in a claim for a combination may be expressed as a means or step for performing a specified function without the recital of structure, material, or acts in support thereof, and such claim shall be construed to cover the corresponding structure, material, or acts described in the specification and equivalents thereof." 35 U.S.C. § 112(6).

at Claims 1, 2 and 10. These are the same tasks described in the plaintiff's proposed definition. In addition, the specification expressly defines the "supervisor unit" as "a microprocessor" (a computer chip) and specifically as "a microprocessor for controlling operation of storage router 56 and to handle mapping and security access for requests between Fibre Channel 52 and SCSI bus 54." See *id.* at 5:7 - 5:10. However, neither the specification (nor the claim language) limits the '972 patent to the specific Intel computer chip referenced by the defendants. Although the defendants correctly point out that the Intel 80960 chip is the only computer chip expressly named in the '972 patent and the specification describes many features this chip, the defendants fail to note that the Intel 80960 chip is listed as only "one implementation" of the claimed invention's microprocessor. See '972 Patent, at 5:63. The defendants are attempting exactly what the Federal Circuit prohibits -- to limit the claims to the preferred embodiment and examples of the specification. "This court has cautioned against limiting the claimed invention to preferred embodiments or specific examples in the specification." *Comark*, 156 F.3d at 1186 (quoting *Texas Instruments, Inc. v. United States Int'l Trade Comm'n*, 805 F.2d 1558, 1563 (Fed. Cir. 1988)). The Court will not use an example of "one implementation" in the specification to limit the plain language of the claims. Accordingly, the Court adopts the plaintiff's definition of "supervisor unit" and will construe that term as used in the claims of the '972 patent to mean "a microprocessor programmed to process data in a buffer in order to map between Fibre Channel devices and SCSI devices and which implements access controls."

V. "SCSI storage devices"

This term is used in claims 1, 4, 7, 9-11 and 14 of the '972 patent. The plaintiff argues that this term essentially needs no further definition because the term SCSI is so well-known in the industry, but proposes that the term can be further defined as "any storage device including, for

example, a tape drive, CD-ROM drive, or a hard disk drive that understands the SCSI protocol and can communicate using the SCSI protocol." See Plaintiff's Brief, at 18. The defendants argue the term should be defined as "any storage device that uses a SCSI standard and has a unique BUS:TARGET:LUN address." See Defendants' Brief, Ex. 2.

The Court agrees with the plaintiff. Essentially, the defendants contend their narrow definition should be used because it "comports with '972 specification" and its discussion of SCSI storage devices. See Defendant's Brief, at 14. However, the specification language referred to by the defendants is only one example of how the SCSI storage device addressing scheme "can" be represented. See '972 Patent, at 7:39. Again, the defendants are impermissibly trying to limit the claim language to an example given in the specification. See *Comark*, 156 F.3d at 1186-87. For the sake of extra clarity, the Court will adopt the plaintiff's proposed definition for this term.

VI. "process data in the buffer"

This phrase is used in claims 1 and 10 of the '972 patent. The plaintiff argues the phrase is adequately defined on its own and by the surrounding claim language. The defendants contend the phrase should be defined as "to manipulate data in the buffer in a manner to (a) achieve mapping between Fibre Channel and SCSI devices, and (b) apply access controls and routing functions." See Defendants' Brief, Ex. 2.

The plain language of claims 1 and 10 disclose that the supervisor unit (the microprocessor) processes data in the buffer "to interface between the Fibre Channel controller and the SCSI controller to allow access from Fibre Channel initiator devices to SCSI storage devices using the native low level, block protocol in accordance with the configuration." See '972 Patent, at Claims 1 and 10. This language adequately describes what it means to "process data in the buffer" for these

claims. Simply because the specification may use slightly different language to describe this "processing," *see id.* at 5:18 - 5:20, does not entitle the defendants to adopt the specification language over the plain language of the claims. The Court will not further define this phrase.

VII. "storage router"

This term is used in claims 1-7 and 10 of the '972 patent. The plaintiff argues the term needs no further definition for claims 1-6, and for claim 7 it should be defined as "a device which provides virtual local storage, maps, implements access controls, and allows access using native low level block protocols." *See* Plaintiff's Brief, at 27. The defendants contend the term should mean "a bridge device that connects a Fibre Channel link directly to a SCSI bus and enables the exchange of SCSI command set information between application clients on SCSI bus devices and the Fibre Channel links." *See* Defendants' Brief, Ex. 2.

The defendants do not make any argument for their proposed definition in their brief, and did not discuss the term at the July 25 hearing. In their notebook of exhibits presented at the hearing, the defendants include one page which supports their definition with a quote from the specification. *See* Defendants' *Markman* Exhibits, "Markman Presentation" Tab, at 22. This argument is disingenuous. The specification language quoted by the defendants is immediately followed by several sentences further defining "storage router." Indeed, the next sentence begins "Further, the storage router applies access controls . . ." *See* '972 Patent, at 5:30. The defendants' attempt to limit the term "storage router" to one of several descriptive sentences in the specification is not well-taken. In addition, the Court finds the term "storage router," as used in all claims of the '972 patent, is adequately described by the additional language of the claims, which discloses in detail the various functions and/or qualities of the storage router. The Court will not further define this term.

VIII. "map"

This term is used in claims 1, 7, 10 and 11 of the '972 patent. The plaintiff contends the term means "to create a path from a device on one side of the storage router to a device on the other side of the router, i.e. from a Fibre Channel device to a SCSI device (or vice-versa). A 'map' contains a representation of devices on each side of the storage router, so that when a device on one side of the storage router wants to communicate to a device on the other side of the storage router, the storage router can connect the devices." See Plaintiff's Brief, at 22. The defendants argue the term means "to translate addresses." See Defendants' Brief, Ex. 2.

In support of their definition, the defendants point only to a dictionary definition of "map." See Defendants' Brief, at 13 and Ex. 4. The plaintiff, on the other hand, cites to specific portions of the specification that support its definitions of map (both as a verb and a noun) as used in the claims of the '972 patent. See Plaintiff's Brief, at 22 (citing '972 Patent, at 1:66-2:5 and 6:65-7:6). Because intrinsic evidence is far more salient than a dictionary definition, and because the Court agrees that the specification language cited by the plaintiff supports its construction of the term "map," the Court will adopt the plaintiff's proposed definition of this term.

IX. "Fibre Channel protocol unit" and "SCSI protocol unit"

These terms are used in claims 5 and 6 of the '972 patent. The plaintiff contends these phrases should be defined as "a portion of the Fibre Channel controller which connects to the Fibre Channel transport medium" and "a portion of the SCSI controller which interfaces to the SCSI bus." See Plaintiff's Brief, at 27. The defendants say the terms mean "block and equivalents thereof that connects to the Fibre Channel transport medium" and "block and equivalents thereof that connects to the SCSI bus transport medium." See Defendants' Brief, Ex. 2.

The defendants argue the means-plus-function analysis of § 112(6) should apply here because the terms are well-known and are not defined in two dictionaries cited by the defendants. See Defendants' Brief, at 7-8, 14-15, Ex. 4 and Ex. 5. However, the defendants do not indicate how the term should be defined in reference to the specification, and in fact contend "the '972 specification fails to reveal any structure corresponding to the claimed function." See *id.* at 8 and 15. The defendants then propose the word "block" should be used to describe these terms because the "protocol units" are "simply depicted as a block within the diagram of Figure 5" of the '972 patent. See *id.* This reasoning is wholly unpersuasive. Simply because a figure in the patent physically depicts the protocol units in a block-like shape, it does not follow that the units should be defined as "blocks or equivalents thereof." Under that reasoning, the SCSI storage devices, which are physically depicted as cylinders in the '972 patent, could be defined simply as "cylinders, oil drums or monkey barrels, or equivalents thereof." As the plaintiff correctly points out, the language of claims 5 and 6 plainly states that the "protocol units" for both devices are part of the "controllers" for the devices, and are intended to "connect" the devices to various "transport media" (i.e., to various cables). See '972 Patent, at Claims 5 and 6. Accordingly, the Court adopts the plaintiff's definitions for these terms, and will construe the terms to mean "a portion of the Fibre Channel controller which connects to the Fibre Channel transport medium" and "a portion of the SCSI controller which interfaces to the SCSI bus."

X. "interface"

In their Joint Stipulation of Claim Construction, the parties claim the meaning of the term "interface" is in dispute. However, this phrase is not discussed in any of the parties' briefs, and neither side presented an argument at the July 25 hearing as to why the term is disputed. This term

has a standard and ordinary meaning – even to a federal judge – and the Court will not further define it.

XI. Undisputed Terms

Finally, in their Joint Stipulation of Claim Construction, the parties have stipulated to the construction of 17 other terms in the '972 patent. The Court will therefore adopt these stipulated constructions, solely for the purpose of this lawsuit.

Accordingly, the Court enters the following order:

IT IS ORDERED that the attached construction of the patent claims will be incorporated into any jury instructions given in this cause and will be applied by the Court in ruling on the issues raised in summary judgment.

SIGNED on this 26th day of July 2000.

UNITED STATES DISTRICT JUDGE

RECEIVED 01/21/2000 12:00 PM
U.S. PATENT NO. 5,941,972

**CONSTRUCTION OF CLAIMS
U.S. PATENT NO. 5,941,972**

Disputed Terms

The phrase "implements access controls for storage space on the SCSI storage devices" means provides controls which limit a computer's access to a specific subset of storage devices or sections of a single storage device.

The phrase "allocation of subsets of storage space to associated Fibre Channel devices, wherein each subset is only accessible by the associated Fibre Channel device" means subsets of storage space are allocated to specific Fibre Channel devices.

A "supervisor unit" is a microprocessor programmed to process data in a buffer in order to map between Fibre Channel devices and SCSI devices and which implements access controls.

A "SCSI storage device" is any storage device including, for example, a tape drive, CD-ROM drive, or a hard disk drive that understands the SCSI protocol and can communicate using the SCSI protocol.

The term "map" means to create a path from a device on one side of the storage router to a device on the other side of the router, *i.e.* from a Fibre Channel device to a SCSI device (or vice-versa). A "map" contains a representation of devices on each side of the storage router, so that when a device on one side of the storage router wants to communicate with a device on the other side of the storage router, the storage router can connect the devices.

A "Fibre Channel protocol unit" is a portion of the Fibre Channel controller which connects to the Fibre Channel transport medium.

A "SCSI protocol unit" is a portion of the SCSI controller which interfaces to the SCSI bus.

Stipulated / Undisputed Terms

A "buffer" is a memory device that is utilized to temporarily hold data.

A "direct memory access (DMA) interface" is a device that acts under little or no microprocessor control to access memory for data transfer.

A "Fibre Channel" is a known high-speed serial interconnect, the structure and operation of which is described, for example, in Fibre Channel Physical and Signaling Interface (FC-PH), ANSI X3.230 Fibre Channel Arbitrated Loop (FC-AL), and ANSI X3.272 Fibre Channel Private Loop Direct Attach (FC-PLDA).

A "Fibre Channel controller" is a device that interfaces with a Fibre Channel transport medium.

A "Fibre Channel device" is any device, such as a computer, that understands Fibre Channel protocol and can communicate using Fibre Channel protocol.

"Fibre Channel protocol" is a set of rules that apply to Fibre Channel.

A "Fibre Channel transport medium" is a serial optical or electrical communications link that connects devices using Fibre Channel protocol.

A "first-in-first-out queue" is a multi-element data structure from which elements can be removed only in the same order in which they were inserted; that is, it follows a first in, first out (FIFO) constraint.

A "hard disk drive" is a well known magnetic storage media, and includes a SCSI hard disk drive.

An "initiator device" is a device that issues requests for data or storage.

"Maintain(ing) a configuration" means keep(ing) a modifiable setting of information.

A "native low level, block protocol" is a set of rules or standards that enable computers to exchange information and do not involve the overhead of high level protocols and file systems typically required by network servers.

A "SCSI" (Small Computer System Interface) is a high speed parallel interface that may be used to connect components of a computer system.

A "SCSI bus transport medium" is a cable consisting of a group of parallel wires (normally 68) that forms a communications path between a SCSI storage device and another device, such as a computer.

A "SCSI controller" is a device that interfaces with the SCSI bus transport medium.

"Virtual local storage" is a specific subset of overall data stored in storage devices that has the appearance and characteristics of local storage.

A "workstation" is a remote computing device that connects to the Fibre Channel, and may consist of a personal computer.

**This Page is Inserted by IFW Indexing and Scanning
Operations and is not part of the Official Record**

BEST AVAILABLE IMAGES

Defective images within this document are accurate representations of the original documents submitted by the applicant.

Defects in the images include but are not limited to the items checked:

- BLACK BORDERS
- IMAGE CUT OFF AT TOP, BOTTOM OR SIDES
- FADED TEXT OR DRAWING
- BLURRED OR ILLEGIBLE TEXT OR DRAWING
- SKEWED/SLANTED IMAGES
- COLOR OR BLACK AND WHITE PHOTOGRAPHS
- GRAY SCALE DOCUMENTS
- LINES OR MARKS ON ORIGINAL DOCUMENT
- REFERENCE(S) OR EXHIBIT(S) SUBMITTED ARE POOR QUALITY
- OTHER: _____

IMAGES ARE BEST AVAILABLE COPY.

As rescanning these documents will not correct the image problems checked, please do not report these problems to the IFW Image Problem Mailbox.

Exhibit B

SS RECEIVED

MAR 10 2003

CLERK, U.S. DISTRICT COURT
WESTERN DISTRICT OF TEXAS
BY [Signature]
DEPUTY CLERK

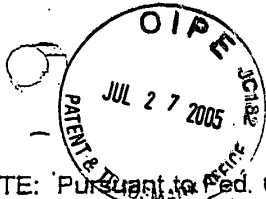

NOTE: Pursuant to Fed. Cir. R. 47.6, this disposition is not citable as precedent. It is a public record. This disposition will appear in tables published periodically.

United States Court of Appeals for the Federal Circuit

02-1158

FILED

MAR 10 2003

CLERK, U.S. DISTRICT COURT
WESTERN DISTRICT OF TEXAS
BY [Signature]
DEPUTY CLERK

CROSSROADS SYSTEMS, (TEXAS), INC.,

Plaintiff-Appellee,

v.

CHAPARRAL NETWORK STORAGE, INC.,

Defendant-Appellant.

FILED
U.S. COURT OF APPEALS FOR
THE FEDERAL CIRCUIT

FEB 12 2003

JUDGMENT

JAN HORBALY
CLERK

ON APPEAL from the United States District Court for
the Western District of Texas

In CASE NO(S). 00-CV-217 and 00-CV-621

This CAUSE having been heard and considered, it is

ORDERED and ADJUDGED: AFFIRMED. See Fed. Cir. R. 36

Per Curiam (NEWMAN, SCHALL, and DYK, Circuit Judges).

CERTIFIED COPY
I HEREBY CERTIFY THIS DOCUMENT
IS A TRUE AND CORRECT COPY
OF THE ORIGINAL ON FILE.

UNITED STATES COURT OF APPEALS
FOR THE FEDERAL CIRCUIT

By: [Signature] Date: 3/15/03

ENTERED BY ORDER OF THE COURT

DATED: FEB 12 2003

[Signature]
Jan Horbaly, Clerk

ISSUED AS A MANDATE: MARCH 5, 2003

Costs Against Appellant:
Total \$97.35

186

03/17/2003 MON 12:47 [FY/RY NO 69781]

BEST AVAILABLE COPY

07-28-05

JFW

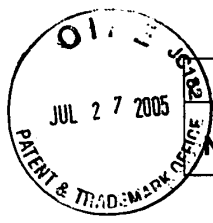

IN THE UNITED STATES PATENT AND TRADEMARK OFFICE

NOTIFICATION OF EXTENSION OF TIME UNDER 37 C.F.R § 1.136

Atty. Docket No. CROSS1120-13

Applicant Geoffrey B. Hoese	
Application Number 10/658,163	Filed 09/09/2003
Title Storage Router and Method for Providing Virtual Local Storage	
Group Art Unit 2182	Examiner Shin, Christopher B.
Confirmation No. 5675	

Commissioner for Patents
P.O. Box 1450
Alexandria, VA 22313-1450

Dear Sir:

Certification Under 37 C.F.R. §1.10

I hereby certify that this document is being deposited with the United States Postal Service as Express Mail to Addressee (Label No. EV704312847US) in an envelope addressed to: Commissioner for Patents, P.O. Box 1450, Alexandria, VA. 22312-1450 on July 27, 2005.

Julie H. Blackard

Applicant hereby takes an Extension of Time for responding to the Office Action date mailed January 27, 2005 for a period of three (3) month(s).

		<i>Small Entity</i>	<i>Large Entity</i>
<input type="checkbox"/>	First Month	\$ 60.00	\$ 120.00
<input type="checkbox"/>	Second Month	\$ 225.00	\$ 450.00
<input checked="" type="checkbox"/>	Third Month	\$ 510.00	\$ 1,020.00
<input type="checkbox"/>	Fourth Month	\$ 795.00	\$ 1,590.00
<input type="checkbox"/>	Fifth Month	\$ 1,080.00	\$ 2,160.00
TOTAL		\$	\$1,020.00

Enclosed is a check in the amount of \$1,020.00 made payable to the Director of the U.S. Patent Office. If any fees are inadvertently omitted, additional fees are required, or if any amounts have been overpaid, please appropriately charge or credit those fees to Deposit Account No. 50-3183 of SPRINKLE IP LAW GROUP.

07/29/2005 CNGUYEN2 00000037 10658163

01 FC:1253

1020.00 DP

Respectfully submitted,
SPRINKLE IP LAW GROUP

John L. Adair
Reg. No. 48,828

Date: July 27, 2005
1301 W. 25th Street, Suite 408
Austin, Texas 78705
(512) 637.9223 - Telephone
(512) 371.9088 - Facsimile

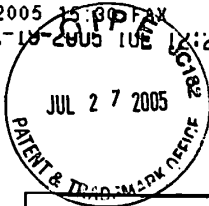

IN THE UNITED STATES PATENT AND TRADEMARK OFFICE	
TERMINAL DISCLAIMER TO OBIVATE A DOUBLE PATENTING REJECTION OVER A PRIOR PATENT	Atty. Docket No. CROSS1120-13
Applicant Geoffrey B. Hoese	
Application Number 10/658,163	Date Filed 09/09/2003
Title Storage Router and Method for Providing Virtual Local Storage	
Group Art Unit 2182	Examiner Shin, Christopher B.
Confirmation Number: 5675	

Commissioner for Patents
P.O. Box 1450
Alexandria, VA 22313-1450

Dear Sir:

07/29/2005 CNGUYEN2 00000037 10658163

02 FC:1814

130.00 OP

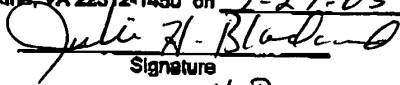
Certificate of Mailing Under 37 C.F.R. 61.10
I hereby certify that this correspondence is being deposited with the United States Postal Service as Express Mail to Addressee in an envelope addressed to Commissioner for Patents, P.O. Box 1450, Alexandria, VA 22312-1450 on <u>7-27-05</u>
 Signature
<u>JULIE H. BLACKARD</u> Printed Name

Crossroads Systems, Inc., owner of one hundred percent (100%) interest in the instant application, as evidenced by the assignment recorded on 12/21/1997 on Reel/Frame: 8929/0290, hereby disclaims, except as provided below, the terminal part of the statutory term of any patent granted on the instant application, which would extend beyond the expiration date of the full statutory term defined in 35 U.S.C. § 154 to 156 and 173 of U.S. Patent No. 5,941,972, U.S. Patent No. 6,425,036, U.S. Patent No. 6,738,854 and/or U.S. Patent No. 6,763,419. The owner hereby agrees that any patent so granted on the instant application shall be enforceable only for and during such period that it and the prior patent are commonly owned. This agreement runs with any patent granted on the instant application and is binding upon the grantee, its successors or assigns.

In making the above disclaimer, the owner does not disclaim the terminal part of any patent granted on the instant application that would extend to the expiration date of the full statutory term as defined in 35 U.S.C. § 154 to 156 and 173 of the prior patents, as presently

Attorney Docket
CROSS1120-13

Customer ID: 44654
Application No. 10/658,183

shortened by any terminal disclaimer, in the event that it later expires for failure to pay a maintenance fee, is held unenforceable, is found invalid by a court of competent jurisdiction, is statutorily disclaimed in whole or terminally disclaimed under 37 C.F.R. 1.321, has all claims canceled by a reexamination certificate, is reissued, or is in any manner terminated prior to the expiration of its full statutory term as presently shortened by any terminal disclaimer.

Check box 1, 2, 3, or 4 as appropriate.

- 1. For submission on behalf of an organization (e.g., corporation, partnership, university, government agency, etc.), the undersigned is empowered to act on behalf of the organization.

I hereby declare that all statements made herein of my own knowledge are true and that all statements made on information and belief are believed to be true; and further that these statements were made with the knowledge that willful false statements and the like so made are punishable by fine or imprisonment, or both, under Section 1001 of Title 18 of the United States Code and that such willful false statements may jeopardize the validity of the application or any patent issued thereon.

Statement under 37 C.F.R. 3.73(b) is required if terminal disclaimer is signed by the assignee (owner). Form PTO/SB/96 may be used for making this certification. See MPEP § 324.

- 2. The undersigned is an attorney or agent of record.
- 3. Terminal disclaimer fee under 37 C.F.R. 1.20(d) included.
- 4. Terminal disclaimer fee under 37 C.F.R. 1.20(d). The Commissioner is hereby authorized to deduct \$130.00 representing the above-noted filing fee from Deposit Account No. 50-3183 of Sprinkle IP Law Group. The Commissioner is hereby further authorized to deduct any deficiencies or credit any overpayments regarding this application from the same account.

 Robert Sims
 Title: President

7/20/05
 Dated

Application Number 	Application/Control No. 10/658,163	Applicant(s)/Patent under Reexamination HOESE ET AL.
Document Code - DISQ		Internal Document – DO NOT MAIL

TERMINAL DISCLAIMER	<input checked="" type="checkbox"/> APPROVED	<input type="checkbox"/> DISAPPROVED
Date Filed : 072705	This patent is subject to a Terminal Disclaimer	

Approved/Disapproved by:
James R. Matthews

U.S. Patent and Trademark Office



RECEIVED
CENTRAL FAX CENTER

JUL 26 2005

1301 W. 25th Street, Suite 408
Austin, Texas 78705
[o] 512.637.9220
[f] 512.371.9088

FAX COVER SHEET

TO: U.S. Patent Office Fax#: 571/273-8300

FROM: Julie H. Blackard Client Matter #: CROSS1120-13
Legal Secretary

DATE: 07/26/05 # of Pages: 2

RE: Revocation and Power of Attorney

Please contact 512.637.9227 if there is a problem with this transmission.

SECOND REQUEST

CONFIDENTIALITY NOTICE

This communication is ONLY for the person named above. Unless otherwise indicated, it contains information that is confidential, privileged or exempt from disclosure under applicable law. If you are not the person named above, or responsible for delivering it to that person, be aware that disclosure, copying, distribution or use of this communication is strictly PROHIBITED. If you have received it in error, or are uncertain as to its proper handling, please immediately notify us by telephone and mail the original to us at the above address. Thank you.

IN THE UNITED STATES PATENT AND TRADEMARK OFFICE	
REVOCATION AND POWER OF ATTORNEY AND CHANGE OF MAILING ADDRESS	Atty. Docket No. (Opt.) CROSS1120-13
Applicants Geoffrey B Hoese, et. al.	
Application Number 10/658,163	Filed 9/9/2003
For STORAGE ROUTER AND METHOD FOR PROVIDING VIRTUAL LOCAL STORAGE	
Group Art Unit 2186	Examiner Unknown
Confirmation No. 5675	

RECEIVED
CENTRAL FAX CENTER
JUL 26 2005

Commissioner for Patents
P.O. Box 1450
Alexandria, VA 22313-1450

Dear Sir:

Certification Under 37 C.F.R. §1.8

I hereby certify that this document is being transmitted to COMMISSIONER FOR PATENTS via facsimile on 8-11, 2004.

Reynetta Deveau
Signed Name

Reynetta Deveau
Printed Name

Crossroads Systems, Inc., 100% owner of the above-identified patent application, as evidenced by the Assignment recorded on December 31, 1997 on Reel/Frame: 8929/0290, hereby revokes all previous Powers of Attorney and appoints the following attorneys under Customer No. 44654, all of the firm of SPRINKLE IP LAW GROUP, to prosecute the above-identified Patent and to transact all business in the Patent and Trademark Office connected therewith.

STEVEN R. SPRINKLE	Registration No. 40,825
JOHN ADAIR	Registration No. 48,828
ARI AKMAL	Registration No. 51,388

Direct all telephone calls and correspondence to:

Customer No. 44654
SPRINKLE IP LAW GROUP
1301 W. 25th Street, Suite 408,
Austin, Texas 78705
Attn: Steven Sprinkle
Tel. 512.637.9220 / Fax 512.371.9088

I hereby state I am authorized to act on behalf of **CROSSROADS SYSTEMS, INC.**

Respectfully submitted,

Crossroads Systems, Inc.

Dated: 8/11, 2004

By: *[Signature]*
Robert Sims, President & CEO

Handwritten initials/signature

IN THE UNITED STATES PATENT AND TRADEMARK OFFICE	
INFORMATION DISCLOSURE STATEMENT BY APPLICANTS	Atty. Docket No. (Opt.) CROSS1120-13



Applicant Geoffrey B. Hoese, et al.	
Application Number 10/658,163	Date Filed 09/09/2003
Title Storage Router and Method for Providing Virtual Local Storage	
Group Art Unit 2182	Examiner Shin, Christopher B.
Confirmation Number: 5675	

Commissioner for Patents
P.O. Box 1450
Alexandria, VA 22313

Certification Under 37 C.F.R. §1.8

I hereby certify that this document is being deposited with the United States Postal Service as First Class Mail in an envelope addressed to: Commissioner for Patents, P.O. Box 1450, Alexandria, VA 22313 on July 13, 2005.

Janice Pampell
Janice Pampell

Applicants respectfully request, pursuant to 37 C.F.R. §§ 1.555, 1.56, 1.97 and 1.98, that the art listed on the attached SBO8-A and SBO8-B forms be considered and cited in the examination of the above-identified application. Since the present Application was filed after June 30, 2003, a copy of any U.S. Patent and any U.S. Patent Application Publications cited on the attached SBO8-A form is not being submitted with this Information Disclosure Statement pursuant to the waiver of 37 C.F.R. § 1.98(a)(2)(i) by the U.S. Patent and Trademark Office. Several documents are included on the enclosed CD-Rom, as well as hard copies for the convenience of the Examiner.

Furthermore, pursuant to 37 C.F.R. §§ 1.97(g) and (h), no representation is made that a search has been made or that this art is material to patentability of the present application. Applicants respectfully submit that the claims of Applicants' above-referenced patent is patentably distinguishable from these references. Applicants respectfully request consideration of these references. The Commissioner is hereby authorized to charge any fees due, or refund any credit, to Deposit Account No. 50-3183 of Sprinkle IP Law Group for any fee under 37 C.F.R. §1.17.

07/26/2005 CNGUYEN2 00000075 10658163
01 FC:1806 180.00 OP

Respectfully submitted,
Sprinkle IP Law Group
Attorneys for Applicants

John L. Adair
John L. Adair
Reg. No. 48,828

Dated: July 13, 2005.
1301 W. 25th Street, Suite 408
Austin, TX 78705
T. 512-637-9220 / F. 512-371-9088

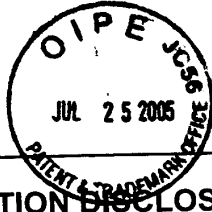

PTO/SB/08A (04-03)

INFORMATION DISCLOSURE STATEMENT BY APPLICANT				Application Number	10/658,163
				Filing Date	09/09/2003
				First Named Inventor	Hoese, Geoffrey
				Group Art Unit	2182
				Examiner Name	Shin, Christopher B.
Sheet	1	OF	4	Attorney Docket Number	CROSS1120-13

U.S. PATENT DOCUMENTS

Examiner Initials	Cite No.	Document Number		Publication Date MM-DD-YYYY	Name of Patentee or Applicant of Cited Document	Pages, Columns, Lines Where Relevant Passages or Figures Appear
		Number	Kind Code (if known)			
	A1	4,415,970		11/15/1983	Swenson, et al.	
	A2	4,455,605		6/19/1984	Cormier, et al.	
	A3	4,504,927		3/12/1985	Callan	
	A4	4,533,996		8/6/1985	Gartung, et al.	
	A5	4,573,152		2/25/1986	Greene, et al.	
	A6	4,603,380		7/29/1986	Easton, et al.	
	A7	4,620,295		10/28/1986	Aiden, Jr.	
	A8	4,644,462		2/17/1987	Matsubara, et al.	
	A9	4,697,232		9/29/1987	Brunelle, et al.	
	A10	4,787,028		11/22/1988	Finforck, et al.	
	A11	4,807,180		2/21/1989	Takeuchi, et al.	
	A12	4,811,278		3/7/1989	Bean, et al.	
	A13	4,821,179		4/11/1989	Jensen, et al.	
	A14	4,825,406		4/25/1989	Bean, et al.	
	A15	4,827,411		5/2/1989	Arrowood, et al.	
	A16	4,835,674		5/30/1989	Collins, et al.	
	A17	4,864,532		9/5/1989	Reeve, et al.	
	A18	4,897,874		1/30/1990	Lidensky, et al.	
	A19	4,961,224		10/2/1990	Yung	
	A20	5,072,378		12/10/1991	Manka	
	A21	5,077,732		12/31/1991	Fischer, et al.	
	A22	5,077,736		12/31/1991	Dunphy, Jr., et al.	
	A23	5,124,987		6/23/1992	Milligan, et al.	
	A24	5,155,845		10/13/1992	Beal, et al.	
	A25	5,185,876		2/9/1993	Nguyen, et al.	
	A26	5,193,168		3/9/1993	Corrigan, et al.	
	A27	5,193,184		3/9/1993	Belsan, et al.	
	A28	5,202,856		4/13/1993	Glider, et al.	

	A29	5,210,866		5/11/1993	Milligan, et al.
	A30	5,212,785		5/18/1993	Powers, et al.
	A31	5,214,778		5/25/1993	Glider, et al.
	A32	5,226,143		7/6/1993	Baird, et al.
	A33	6,239,632		08/24/93	Larner
	A34	5,239,654		8/24/1993	Ing-Simmons
	A35	5,247,638		9/21/1993	O'Brien, et al.
	A36	5,247,692		9/21/1993	Fujimura
	A37	5,297,262		3/22/1994	Cox, et al.
	A38	5,301,290		4/5/1994	Tetzlaff, et al.
	A39	5,315,657		5/24/2994	Abadi, et al.
	A40	5,317,693		7/19/1994	Elko, et al.
	A41	5,331,673		7/19/1994	Elko, et al.
	A42	5,361,347		11/1/1994	Glider, et al.
	A43	5,367,646		11/22/1994	Pardillos, et al.
	A44	5,379,385		1/3/1995	Shomler
	A45	5,379,398		1/3/1995	Cohn, et al.
	A46	5,388,243		2/7/1995	Gilder, et al.
	A47	5,388,246		2/7/1995	Kasi
	A48	5,394,526		2/28/1995	Crouse et al.
	A49	5,396,596		3/7/1995	Hashemi, et al.
	A50	5,403,639		4/4/1995	Belsan, et al.
	A51	5,410,667		4/25/1995	Belsan, et al.
	A52	5,410,697		4/25/1995	Baird, et al.
	A53	5,416,915		5/16/1995	Mattson, et al.
	A54	5,418,909		5/23/1995	Jachowski, et al.
	A55	5,420,988		5/30/1995	Elliott
	A56	5,423,026		6/6/1995	Cook, et al.
	A57	5,426,637		6/20/1995	Derby, et al
	A58	5,430,855		7/4/1995	Wash, et al.
	A59	5,450,570		9/12/1995	Richek, et al.
	A60	5,452,421		9/19/1995	Beardsley, et al.
	A61	5,459,857		10/17/1995	Ludlam, et al.
	A62	5,463,754		10/31/1995	Beausoleil, et al.
	A63	5,469,576		11/21/1995	Dauerer, et al.
	A64	5,471,609		11/28/1995	Yudfriend
	A65	5,487,077		1/23/1996	Hassner, et al.
	A66	5,495,474		2/27/1996	Olnowich, et al.
	A67	5,496,576		3/5/1996	Jeong

	A68	5,504,857		4/2/1996	Baird, et al.
	A69	5,507,032		4/9/1996	Kimura
	A70	5,511,169		4/23/1996	Suda
	A71	5,519,695		5/21/1996	Purohit, et al.
	A72	5,530,845		6/25/1996	Hiatt, et al.
	A73	5,535,352		7/9/1996	Bridges, et al.
	A74	5,537,585		7/16/1996	Blickerstaff, et al.
	A75	5,544,313		8/6/1996	Shachnai, et al.
	A76	5,548,791		8/20/1996	Casper, et al.
	A77	5,564,019		10/8/1996	Beausoleil, et al.
	A78	5,568,648		10/22/1996	Coscarella, et al.
	A79	5,581,709		12/3/1996	Ito, et al.
	A80	5,581,724		12/3/1996	Belsan et al.
	A81	5,613,082		3/18/1997	Brewer, et al.
	A82	5,621,902		4/15/1997	Cases, et al.
	A83	5,632,012		5/20/1997	Belsan, et al.
	A84	5,634,111		5/27/1997	Oeda, et al.
	A85	5,638,518		6/10/1997	Malladi
	A86	5,642,515		6/24/1997	Jones, et al.
	A87	5,659,756		8/19/1997	hefferon, et al.
	A88	5,664,107		9/2/1997	Chatwanni, et al.
	A89	5,727,218		3/10/1998	Hotchkin
	A90	5,743,847		4/28/1998	Nakamura, et al.
	A91	5,781,715		7/14/1998	Sheu
	A92	5,802,278		9/1/1998	Ishfeld, et al.
	A93	5,805,816		9/8/1998	Picazo, Jr., et al.
	A94	5,860,137		1/12/1999	Raz, et al.
	A95	5,867,648		2/2/1999	Foth, et al.
	A96	5,889,952		3/30/1999	Hunnicut, et al.
	A97	5,913,045		6/15/1999	Gillespie, et al.
	A98	5,923,557		7/13/1999	Eidson
	A99	5,933,824		8/3/1999	DeKoning, et al.
	A100	5,935,260		8/10/1999	Ofer
	A101	5,949,994		9/28/1999	Boggs, et al.
	A102	5,953,511		9/14/1999	Sescilia, et al.
	A103	5,959,994		9/28/1999	Boggs, et al.
	A104	5,974,530		10/26/1999	Young
	A105	6,021,451		2/1/2000	Bell, et al.
	A106	6,055,603		4/25/2000	Ofer, et al.

	A107	6,065,087			5/16/2000	Keaveny, et al.			
	A108	6,073,218			6/6/2000	DeKoning, et al.			
	A109	6,075,863			6/13/2000	Krishnan, et al.			
	A110	6,081,849			6/27/2000	Born, et al.			
	A111	6,098,149			8/1/2000	Ofer, et al.			
	A112	6,108,684			8/22/2000	DeKoning, et al.			
	A113	6,118,766			9/12/2000	Akers			
	A114	6,148,004			11/14/2000	Nelson, et al.			
	A115	6,209,023			3/27/2001	Dimitroff, et al.			
	A116	6,230,218			5/8/2001	Casper, et al.			
	A117	6,341,315			1/22/2002	Arroyo, et al.			
	A118	6,343,324			1/29/2002	Hubis, et al.			
	A119	6,425,036			7/23/2002	Hoese, et al.			
	A120	6,484,245			11/19/2002	Sanada, et al.			
Examiner Initials	FOREIGN PATENT DOCUMENTS			Country Code	Number	Kind Code (if known)	Publication Date MM-DD-YYYY (Number 43)	Name of Patentee or Applicant of Cited Document	Pages, Columns, Lines Where Relevant Passages or Figures Appear
	B1	GB 2341715							
	B2	JP 6301607							
	B3	WO 98/36357				1998			
Examiner Signature						Date Considered			

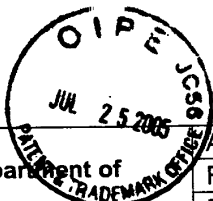

FORM PTO 1449 US Department of Commerce Patent and Trademark Office		Application Number	10/658,163		
		Filing Date	09/09/2003		
		First Named Inventor	Geoffrey B. Hoese		
		Group Art Unit	2182		
		Examiner Name	Shin, Christopher B.		
Sheet	1	of	7	Atty Docket Number	CROSS1120-13
Examiner Initials	Cite No.	OTHER PRIOR ART -- NON PATENT LITERATURE DOCUMENTS		Date	
	C1	Decision Returning Petition mailed February 28, 2005			
	C2	Block-Based Distributed File Systems, Anthony J. McGregor, July 1997			
	C3	Compaq StorageWorks HSG80 Array Controller ACS Version 8.3 (Maintenance and Service Guide) 11/98			
	C4	Compaq StorageWorks HSG80 Array Controller ACS Version 8.3 (Configuration and CLI Reference Guide) 11/98			
	C5	CRD-5500 SCSI RAID Controller User's Manual CMD Technology, Inc. pp. 1-1 to 6-25, revised November 21, 1996.		11/21/1996	
	C6	DIGITAL Storage Works, HSZ70 Array Controller, HSOF Version 7.0 EK-HSZ70-CG. A01, Digital Equipment Corporation, Maynard, Massachusetts			
	C7	DIGITAL StorageWorks HSZ70 Array Controller HSOF Version 7.0 EK-HSZ270-RM. A01 CLI Reference Manual			
	C8	DIGITAL StorageWorks HSZ70 Array Controller HSOF Version 7.0 EK-HSZ70-SV. A01			1997-
	C9	DIGITAL StorageWorks HSG80 Array Controller ACS Version 8.0 (User's Guide 1/98)			
	C10	DP5380 Asynchronous SCSI Interface, National Semiconductor Corporation, Arlington, TX, May 1989, pp. 1-32			
	C11	Emerson, "Ancor Communications: Performance evaluation of switched fibre channel I/O system using--FCP for SCSI" February 1995, IEEE, pp. 479-484		2/1/1995	
	C12	Fibre Channel and ATM: The Physical Layers, Jerry Quam WESCON/94, published 27-29 September 1994. Pages 648-652.			
	C13	Fiber Channel storage interface for video-on-demand servers by Anzaloni, et al.		6/15/1905	
	C14	Gen5 S-Series XL System Guide Revision 1.01 by Chen		6/18/1905	
	C15	Graphical User Interface for MAXSTRAT Gen5/Gen-S Servers User's guide 1.1		6/11/1996	
	C16	High Performance Data transfers Using Network-Attached Peripherals at the national Storage Laboratory by Hyer		2/26/1993	
	C17	IFT-3000 SCSI to SCSI Disk array Controller Instruction Manual Revision 2.0 by Infotrend Technologies, Inc.		1995-	
	C18	Implementing a Fibre Channel SCSI transport by Snively		1994-	
	C19	"InfoServer 150--Installation and Owner's Guide", EK-INFSV-OM-001, Digital Equipment Corporation, Maynard, Massachusetts 1991, Chapters 1 and 2			
	C20	InfoServer 150VXT Photograph			
	C21	Infoserver 100 System Operations Guide, First Edition Digital Equipment Corporation, 1990			
	C22	Johnson, D.B., et al., "The Peregrine High Performance RPC System", Software-Practice and Experience, 23(2):201-221, Feb. 1993			
	C23	Local-Area networks for the IBM PC by Haugdahl			
	C24	Misc. Reference Manual Pages, SunOS 5.09			

FORM PTO 1449 US Department of Commerce Patent and Trademark Office				Application Number	10/658,163
				Filing Date	09/09/2003
				First Named Inventor	Geoffrey B. Hoese
				Group Art Unit	2182
				Examiner Name	Shin, Christopher B.
Sheet	2	of	7	Atty Docket Number	CROSS1120-13
Examiner Initials	Cite No.	OTHER PRIOR ART -- NON PATENT LITERATURE DOCUMENTS			Date
	C25	New serial I/Os speed storage subsystems by Bursky			2/6/1995
	C26	Petal: Distributed Virtual Disks, Edward K. Lee and Chandramohan A. Thekkath, ACM SIGPLAN Notices, Volume 31, Issue 9, September 1996, pages 84-92.			
	C27	Pictures of internal components of the InfoServer 150, taken from http://bindarydinosaurs.couk/Museum/Digital/infoserver/infoserver.php in Nov. 2004.			
	C28	Raidtec FibreArray and Raidtec FlexArray UltraRAID Systems", Windows IT PRO Article, October 1997			
	C29	S.P. Joshi, "Ethernet controller chip interfaces with variety of 16-bit processors," electronic Design, Hayden Publishing Co., Inc., Rochelle Part, NJ, October 14, 1982. pp 193-200			
	C30	Simplest Migration to Fibre Channel Technology" Article, Digital Equipment Corporation, November 10, 1997, published on PR Newswire			11/10/1997
	C31	Systems Architectures Using Fibre Channel, Roger Cummings, Twelfth IEEE Symposium on Mass Storage Systems, Copyright 1993 IEEE. Pages 251-256			
	C32	Dot Hill's Request to Exceed Page Limit in Motion for Summary Judgment filed June 29, 2005. Case No. A-03-CV-754 (SS)			
	C33	Request for Ex Parte Reexamination for 6,425,035. Third Party Requester: William A. Blake			
	C34	Request for Ex Parte Reexamination for 6,425,035. Third Party Requester: Natu J. Patel			
	C35	Office Action dated 01/21/03 for 10/174,720 (CROSS1120-8)			1/21/2003
	C36	Office Action dated 02/27/01 for 09/354,682 (CROSS1120-1)			2/27/2001
	C37	Office Action dated 08/11/00 for 09/354,682 (CROSS1120-1)			8/11/2000
	C38	Office Action dated 12/16/99 for 09/354,682 (CROSS1120-1)			12/16/1999
	C39	Office Action dated 11/06/02 for 10/023,786 (CROSS1120-4)			11/6/2002
	C40	Office Action dated 01/21/03 for 10/081,110 (CROSS1120-5)			1/21/2003
	C41	Office Action in Ex Parte Reexamination 90/007,127, mailed 02/07/05.			2/7/2005
	C42	Reply to Office Action Under Ex Parte Reexamination Dated 02/02/07 for 90/007,127 filed on 04/06/05.			
	C43	Office Action in Ex Parte Reexamination 90/007,125, mailed 02/07/05.			2/7/2005
	C44	Reply to Office Action Under Ex Parte Reexamination Dated 02/02/07 for 90/007,125 and 90/007,317 filed on 04/06/05.			
	C45	Office Action in Ex Parte Reexamination 90/007,126, mailed 02/07/05.			2/7/2005
	C46	Reply to Office Action Under Ex Parte Reexamination Dated 02/02/07 for 90/007,126 filed on 04/06/05.			
	C47	Office Action in Ex Parte Reexamination 90/007,124, mailed 02/07/05.			2/7/2005
	C48	Reply to Office Action Under Ex Parte Reexamination Dated 02/02/07 for 90/007,124 filed on 04/06/05.			
	C49	Office Action in Ex Parte Reexamination 90/007,123, mailed 02/07/05.			2/7/2005

FORM PTO 1449 US Department of Commerce Patent and Trademark Office				Application Number	10/658,163
				Filing Date	09/09/2003
				First Named Inventor	Geoffrey B. Hoese
				Group Art Unit	2182
				Examiner Name	Shin, Christopher B.
Sheet	3	of	7	Atty Docket Number	CROSS1120-13
Examiner Initials	Cite No.	OTHER PRIOR ART -- NON PATENT LITERATURE DOCUMENTS			Date
	C50	Reply to Office Action Under Ex Parte Reexamination Dated 02/02/07 for 90/007,123 filed on 04/05/05.			
	C51	European Office Action issued April 1, 2004 in Application No. 98966104.6-2413			4/1/2004
	C52	Fiber Channel (FCS)/ATM Interworking: A Design Solution by Anzaloni, et al.			
		Copies of the following are on the attached CD-Rom			
	C53	Defendant's First Supplemental Trial Exhibit List, Crossroads Systems, Inc., v. Chaparral Network Storage, Inc., C.A. No. A-00CA-217-SS (W.D. Tex. 2001). (CD-Rom) .			
	C54	Defendant's Third Supplemental Trial Exhibit List, Crossroads Systems, Inc. v. Pathlight Technology, Inc., C.A. No. A-00CA-248-SS (W.D. Tex. 2001) (CD-Rom) .			
	C55	Defendant Chaparral Network Storage, Inc.'s First Supplemental Trial Exhibit List (D1 through D271) (CD-ROM Chaparral Exhibits ExList_Def) .			9/2/2001
	C56	Plaintiff's Fourth Amended Trail Exhibit List, Crossroads Systems, Inc. v. Chaparral Network Storage, Inc, C.A. No. A-00CA-217-SS (W.D. Tex. 2001) (CD-Rom) .			9/11/2001
	C57	Plaintiff's Revised Trial Exhibit List, Crossroads Systems, Inc. v. Pathlight Technology, Inc., C.A. No. A-00CA-248-SS (W.D. Tex. 2001). (CD-Rom) .			
	C58	Trail Transcripts, Crossroads Systems, Inc. v. Chaparral Network Storage, Inc., C.A. No. A-00CA-217-SS (W.D. Tex. 2001) (CD-Rom) .			
	C59	Trail Transcripts, Crossroads Systems, Inc. v. Pathlight Technology, Inc., C.A. No. A-00CA-248-SS (W.D. Tex. 2001). (CD-Rom) .			

FORM PTO 1449 US Department of Commerce Patent and Trademark Office				Application Number	10/658,163
				Filing Date	09/09/2003
				First Named Inventor	Geoffrey B. Hoese
				Group Art Unit	2182
				Examiner Name	Shin, Christopher B.
Sheet	4	of	7	Atty Docket Number	CROSS1120-13
Examiner Initials	Cite No.	OTHER PRIOR ART -- NON PATENT LITERATURE DOCUMENTS			Date
	C60	Datasheet for CrossPoint 4100 Fibre Channel to SCSI Router (Dedek Ex 41 (ANCT 117-120)) (CD-ROM Chaparral Exhibits D012).			
	C61	Symbios Logic- Software Interface Specification Series 3 SCSI RAID Controller Software Release 02.xx (Engelbrecht Ex 2 (LSI 1421-1658)) (CD-ROM Chaparral Exhibits D013).			12/3/1997
	C62	Press Release- Symbios Logic to Demonstrate Strong Support for Fibre Channel at Fall Comdex (Engelbrecht 12 (LSI 2785-86)) (CD-ROM Chaparral Exhibits D016).			11/13/1996
	C63	OEM Datasheet on the 3701 Controller (Engelbrecht 13 (LSI 01837-38)) (CD-ROM Chaparral Exhibits D017).			6/17/1905
	C64	Nondisclosure Agreement Between Adaptec and Crossroads Dated 10/17/96 (Quisenberry Ex 25 (CRDS 8196)) (CD-ROM Chaparral Exhibits D020).			10/17/1996
	C65	Organizational Presentation on the External Storage Group (Lavan Ex 1 (CNS 182242-255)) (CD-ROM Chaparral Exhibits D021).			4/11/1996
	C66	Bridge. C, Bridge Between SCSI-2 and SCSI-3 FCP (Fibre Channel Protocol) (CD-ROM Chaparral Exhibits P214).			
	C67	Bridge Phase II Architecture Presentation (Lavan Ex 2 (CNS 182287-295)) (CD-ROM Chaparral Exhibits D022).			4/12/1996
	C68	Attendees/Action Items from 4/12/96 Meeting at BTC (Lavan Ex 3 (CNS 182241)) (CD-ROM Chaparral Exhibits D023).			4/12/1996
	C69	Brooklyn Hardware Engineering Requirements Documents, Revision 1.4 (Lavan Ex 4 (CNS 178188-211)) (CD-ROM Chaparral Exhibits D024) by Pecone.			5/26/1996
	C70	Brooklyn Single-Ended SCSI RAID Bridge Controller Hardware OEM Manual, Revision 2.1 (Lavan EX 5 (CNS 177169-191)) (CD-ROM Chaparral Exhibits D025).			3/21/1996
	C71	Coronado Hardware Engineering Requirements Document, Revision 0.0 (Lavan Ex 7 (CNS 176917-932)) (CD-ROM Chaparral Exhibits D027) by O'Dell.			9/30/1996
	C72	ESS/FPG Organization (Lavan Ex 8 (CNS 178639-652)) (CD-ROM Chaparral Exhibits D028).			12/6/1996
	C73	Adaptec MCS ESS Presents: Intelligent External I/O Raid Controllers "Bridge" Strategy (Lavan Ex 9 (CNS 178606-638)). (CD-ROM Chaparral Exhibits D029).			2/6/1996
	C74	AEC-7313 Fibre Channel Daughter Board (for Brooklyn) Engineering Specification, Revision 1.0 (Lavan Ex 10 (CNS 176830-850)) (CD-ROM Chaparral Exhibits D030).			2/27/1997
	C75	Bill of Material (Lavan Ex 14 (CNS 177211-214)) (CD-ROM Chaparral Exhibits D034).			7/24/1997
	C76	AEC-. 4412B, AEC-7412/B2 External RAID Controller Hardware OEM Manual, Revision 2.0 (Lavan Ex 15 (CNS 177082-123)) (CD-ROM Chaparral Exhibits D035).			6/27/1997

FORM PTO 1449 US Department of Commerce Patent and Trademark Office			Application Number	10/658,163	
			Filing Date	09/09/2003	
			First Named Inventor	Geoffrey B. Hoese	
			Group Art Unit	2182	
			Examiner Name	Shin, Christopher B.	
Sheet	5	of	7	Atty Docket Number	CROSS1120-13
Examiner Initials	Cite No.	OTHER PRIOR ART -- NON PATENT LITERATURE DOCUMENTS			Date
	C77	Coronado II, AEC-7312A Fibre Channel Daughter (for Brooklyn) Hardware Specification, Revision 1.2 (Lavan Ex 16 (CNS 177192-210)) (CD-ROM Chaparral Exhibits D036) by Tom Yang.			7/18/1997
	C78	AEC-4412B, AEC7412/3B External RAID Controller Hardware OEM Manual, Revision 3.0. (Lavan Ex 17 (CNS 177124-165)) (CD-ROM Chaparral Exhibits D037).			8/25/1997
	C79	Memo Dated 8/15/97 to AEC-7312A Evaluation Unit Customers re: B001 Release Notes (Lavan Ex 18 (CNS 182878-879)) (CD-ROM Chaparral Exhibits D038).			8/15/1997
	C80	Brooklyn Main Board (AES-0302) MES Schedule (Lavan Ex 19 (CNS 177759-763)) (CD-ROM Chaparral Exhibits D039).			2/11/1997
	C81	News Release-Adaptec Adds Fibre Channel Option to its External RAID Controller Family (Lavan Ex 20 (CNS 182932-934)) (CD-ROM Chaparral Exhibits D040).			5/6/1997
	C82	AEC-4412B/7412B User's Guide, Rev. A (Lavan Ex 21) (CD-ROM Chaparral Exhibits D041).			6/19/1905
	C83	Data Book- AIC-7895 PCI Bus Master Single Chip SCSI Host Adapter (Davies Ex 1 (CNS 182944-64)) (CD-ROM Chaparral Exhibits D046).			5/21/1996
	C84	Data Book- AIC-1160 Fibre Channel Host Adapter ASIC (Davies Ex 2 (CNS 181800-825)) (CD-ROM Chaparral Exhibits D047).			6/18/1905
	C85	Viking RAID Software (Davies Ex 3 (CNS 180969-181026)) (CD-ROM Chaparral Exhibits D048).			6/18/1905
	C86	Header File with Structure Definitions (Davies Ex 4 (CNS 180009-018)) (CD-ROM Chaparral Exhibits D049).			8/8/1996
	C87	C++ SourceCode for the SCSI Command Handler (Davies Ex 5 (CNS 179136-168)) (CD-ROM Chaparral Exhibits D050).			8/8/1996
	C88	Header File Data Structure (Davies Ex 6 (CNS 179997-180008)) (CD-ROM Chaparral Exhibits D051).			1/2/1997
	C89	SCSI Command Handler (Davies Ex 7 (CNS 179676-719)) (CD-ROM Chaparral Exhibits D052).			1/2/1997
	C90	Coronado: Fibre Channel to SCSI Intelligent RAID Controller Product Brief (Kalwitz Ex 1 (CNS 182804-805)) (CD-ROM Chaparral Exhibits D053).			
	C91	Bill of Material (Kalwitz Ex 2 (CNS 181632-633)) (CD-ROM Chaparral Exhibits D054).			3/17/1997
	C92	Emails Dated 1/13-3/31/97 from P. Collins to Mo re: Status Reports (Kalwitz Ex 3 (CNS 182501-511)) (CD-ROM Chaparral Exhibits D055).			
	C93	Hardware Schematics for the Fibre Channel Daughtercard Coronado (Kalwitz Ex 4 (CNS 181639-648)) (CD-ROM Chaparral Exhibits D056).			
	C94	Adaptec Schematics re AAC-340 (Kalwitz Ex 14 CNS 177215-251)) (CD-ROM Chaparral Exhibits D057).			
	C95	Bridge Product Line Review (Manzanares Ex 3 (CNS 177307-336)) (CD-ROM Chaparral Exhibits D058).			
	C96	AEC Bridge Series Products-Adaptec External Controller RAID Products Pre-Release Draft, v.6 (Manzanares Ex 4 (CNS 174632-653)). (CD-ROM Chaparral Exhibits D059).			10/28/1997

FORM PTO 1449 US Department of Commerce Patent and Trademark Office			Application Number	10/658,163	
			Filing Date	09/09/2003	
			First Named Inventor	Geoffrey B. Hoese	
			Group Art Unit	2182	
			Examiner Name	Shin, Christopher B.	
Sheet	6	of	7	Atty Docket Number	CROSS1120-13
Examiner Initials	Cite No.	OTHER PRIOR ART -- NON PATENT LITERATURE DOCUMENTS			Date
	C97	Hewlett-Packard Roseville Site Property Pass for Brian Smith (Dunning Ex 14 (HP 489) (CD-ROM Chaparral Exhibits D078).			11/7/1996
	C98	Distribution Agreement Between Hewlett-Packard and Crossroads (Dunning Ex 15 (HP 326-33) (CD-ROM Chaparral Exhibits D079).			
	C99	HPFC-5000 Tachyon User's Manuel, First Edition (PTI 172419-839) (CD-ROM Chaparral Exhibits D084).			5/1/1996
	C100	X3T10 994D - (Draft) Information Technology: SCSI-3 Architecture Model, Rev. 1.8 (PTI 165977) (CD-ROM Chaparral Exhibits D087).			
	C101	X3T10 Project 1047D: Information Technology- SCSI-3 Controller Commands (SCC), Rev, 6c (PTI 166400-546) (CD-ROM Chaparral Exhibits D088).			9/3/1996
	C102	X3T10 995D- (Draft) SCSI-3 Primary Commands, Rev. 11 (Wanamaker Ex 5 (PTI 166050-229)) (CD-ROM Chaparral Exhibits D089).			11/13/1996
	C103	VBAR Volume Backup and Restore (CRDS 12200-202) (CD-ROM Chaparral Exhibits D099).			
	C104	Preliminary Product Literature for Infinity Commstor's Fibre Channel to SCSI Protocol Bridge (Smith Ex 11; Quisenberry Ex 31 (SPLO 428-30) (CD-ROM Chaparral Exhibits D143).			8/19/1996
	C105	Letter dated 7/12/96 from J. Boykin to B. Smith re: Purchase Order for Evaluation Units from Crossroads (Smith Ex 24) CRDS 8556-57) (CD-ROM Chaparral Exhibits D144).			7/12/1996
	C106	CrossPoint 4100 Fibre Channel to SCSI Router Preliminary Datasheet (Hulsey Ex 9 (CRDS 16129-130)) (CD-ROM Chaparral Exhibits D145).			11/1/1996
	C107	CrossPoint 4400 Fibre Channel to SCSI Router Preliminary Datasheet (Bardach Ex. 9, Quisenberry Ex 33 (CRDS 25606-607)) (CD-ROM Chaparral Exhibits D153).			11/1/1996
	C108	Fax Dated 07/22/96 from L. Petti to B. Smith re: Purchase Order from Data General for FC2S Fibre to Channel SCSI Protocol Bridge Model 11 (Smith Ex 25; Quisenberry Ex 23; Bardach Ex 11 (CRDS 8552-55; 8558) (CD-ROM Chaparral Exhibits D155).			
	C109	Email Dated 12/20/96 from J. Boykin to B. Smith re: Purchase Order for Betas in February and March (Hoese Ex 16, Quisenberry Ex 25; Bardach Ex 12 (CRDS 13644-650) (CD-ROM Chaparral Exhibits D156).			
	C110	Infinity Commstor Fibre Channel Demo for Fall Comdex, 1996 (Hoese Ex 15, Bardach Ex 13 (CRDS 27415) (CD-ROM Chaparral Exhibits D157).			
	C111	Fax Dated 12/19/96 from B. Bardach to T. Rarich re: Purchase Order Information (Bardach Ex. 14; Smith Ex 16 (CRDS 4460)) (CD-ROM Chaparral Exhibits D158).			
	C112	Miscellaneous Documents Regarding Comdex (Quisenberry Ex 2 (CRDS 27415-465)) (CD-ROM Chaparral Exhibits D165).			
	C113	CrossPoint 4100 Fibre Channel to SCSI Router Preliminary Datasheet (Quisenberry) Ex 3 (CRDS 4933-34) (CD-ROM Chaparral Exhibits D166) (CD-ROM Chaparral Exhibits D166).			

FORM PTO 1449 US Department of Commerce Patent and Trademark Office			Application Number	10/658,163	
			Filing Date	09/09/2003	
			First Named Inventor	Geoffrey B. Hoese	
			Group Art Unit	2182	
			Examiner Name	Shin, Christopher B.	
Sheet	7	of	7	Atty Docket Number	CROSS1120-13
Examiner Initials	Cite No.	OTHER PRIOR ART -- NON PATENT LITERATURE DOCUMENTS			Date
	C114	CrossPoint 4400 Fibre to Channel to SCSI Router Preliminary Datasheet; Crossroads Company and Product Overview (Quisenberry Ex 4 (CRDS 25606; 16136)) (CD-ROM Chaparral Exhibits D167).			
	C115	Crossroads Purchase Order Log (Quisenberry Ex 9 (CRDS 14061-062)) (CD-ROM Chaparral Exhibits D172).			
	C116	RAID Manager 5 with RDAC 5 for UNIX V.4 User's Guide (LSI-01854) (CD-ROM Chaparral Exhibits P062).			9/1/1996
	C117	Letter dated May 12, 1997 from Alan G. Leal to Barbara Bardach enclosing the original OEM License and Purchase Agreement between Hewlett-Packard Company and Crossroads Systems, Inc. (CRDS 02057) (CD-ROM Chaparral Exhibits P130).			
	C118	CR4x00 Product Specification (CRDS 43929) (CD-ROM Chaparral Exhibits P267).			6/1/1998
	C119	Symbios Logic – Hardware Functional Specification for the Symbios Logic Series 3 Fibre Channel Disk Array Controller Model 3701 (Engelbrecht Ex 3 (LSI-1659-1733)) (CD-ROM Pathlight Exhibits D074).			
	C120	Report of the Working Group on Storage I/O for Large Scale Computing; Department of Computer Science Duke University: CS-1996-21 (PTI 173330-347). (CD-ROM Pathlight Exhibits D098).			
	C121	Brian Allison's 1999 Third Quarter Sales Plan (PDX 38) CNS 022120-132)) (CD-ROM Pathlight Exhibits D201).			6/5/2001
	C122	Brooklyn SCSI-SCSI Intelligent External RAID Bridge Definition Phase External Documentation (CD-ROM Pathlight Exhibits D129).			
Examiner Signature					Date Considered

81

(12) UK Patent Application (19) GB (11) 2 341 715 (13) A
(43) Date of A Publication 22.03.2000

<p>(21) Application No 9820213.8</p> <p>(22) Date of Filing 17.09.1998</p>	<p>(51) INT CL⁷ G11B 20/18</p> <p>(52) UK CL (Edition R) G5R RB33 RGB</p>
<p>(71) Applicant(s) Springtek Limited (Incorporated in the United Kingdom) Unit 3 Ashbrook Mews, Westbrook Street, BLEWBURY, Oxon, OX11 9QA, United Kingdom</p> <p>(72) Inventor(s) Andrew Paul George Randall</p> <p>(74) Agent and/or Address for Service Atkinson Burrington The Technology Park, 60 Shirland Lane, SHEFFIELD, S9 3SP, United Kingdom</p>	<p>(56) Documents Cited EP 0795812 A1 EP 0717357 A2 EP 0569313 A2 EP 0569236 A2 EP 0485110 A2 EP 0450801 A2 WO 93/18455 A1 WO 91/20076 A1 WO 91/14982 A1 US 5651132 A</p> <p>(58) Field of Search UK CL (Edition P) G4A AES, G5R RAC RB33 RGB INT CL⁶ G06F 11/10, G11B 20/18 EDOC WPI</p>

BEST AVAILABLE COPY

(54) Abstract Title
Magnetic disk redundant array

(57) A plurality of magnetic disk drives (301, 302, 303) are configured to store machine readable data in a protected way such that data is recoverable in the event of a single disk failure. The array of disks is housed for application directly into an existing disk bay of a computer (101). The array is connectable to the computer as if it were a single conventional computer disk and the drives are controlled by an operating system on the computer as if they were a single storage volume.

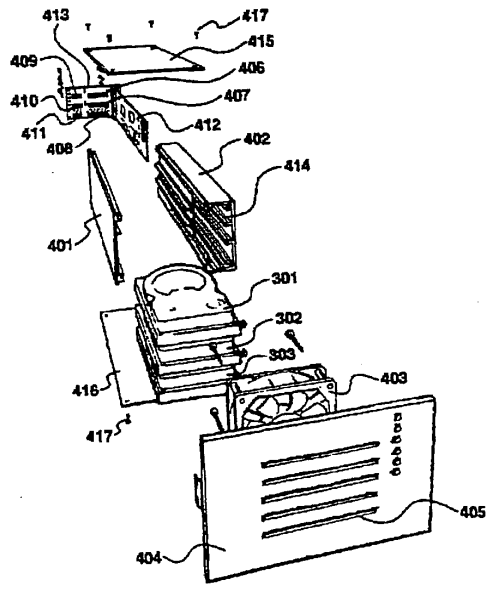

Figure 4

At least one drawing originally filed was informal and the print reproduced here is taken from a later filed formal copy.
This print takes account of replacement documents submitted after the date of filing to enable the application to comply with the formal requirements of the Patents Rules 1995

GB 2 341 715 A

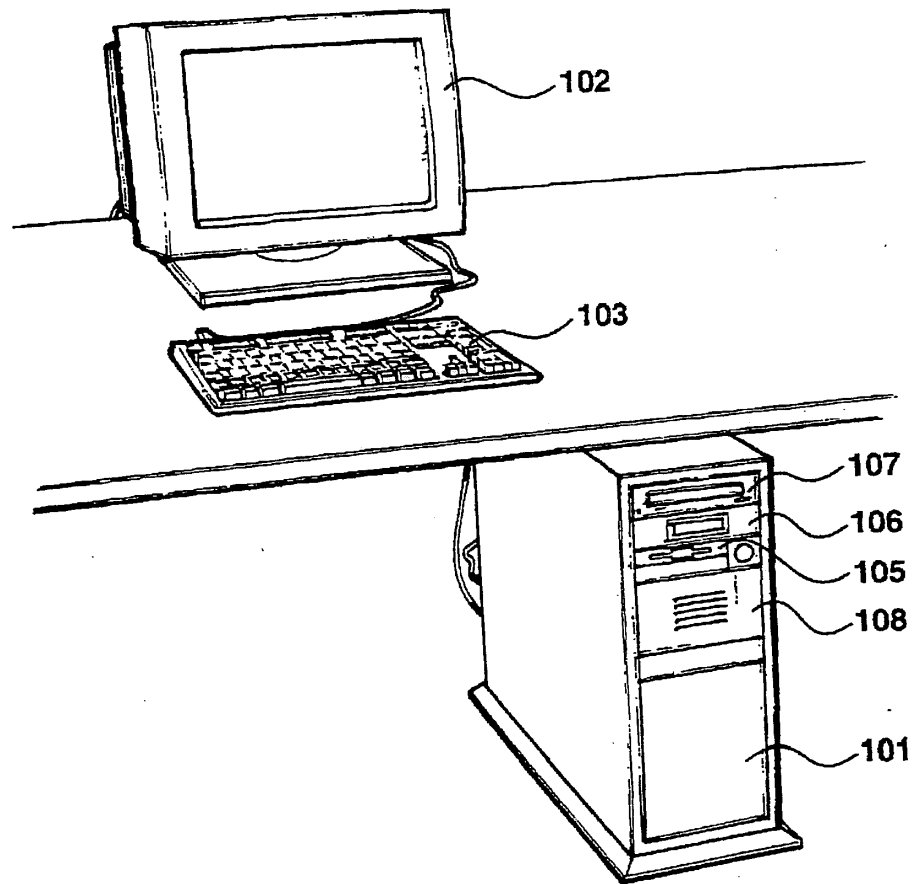

Figure 1

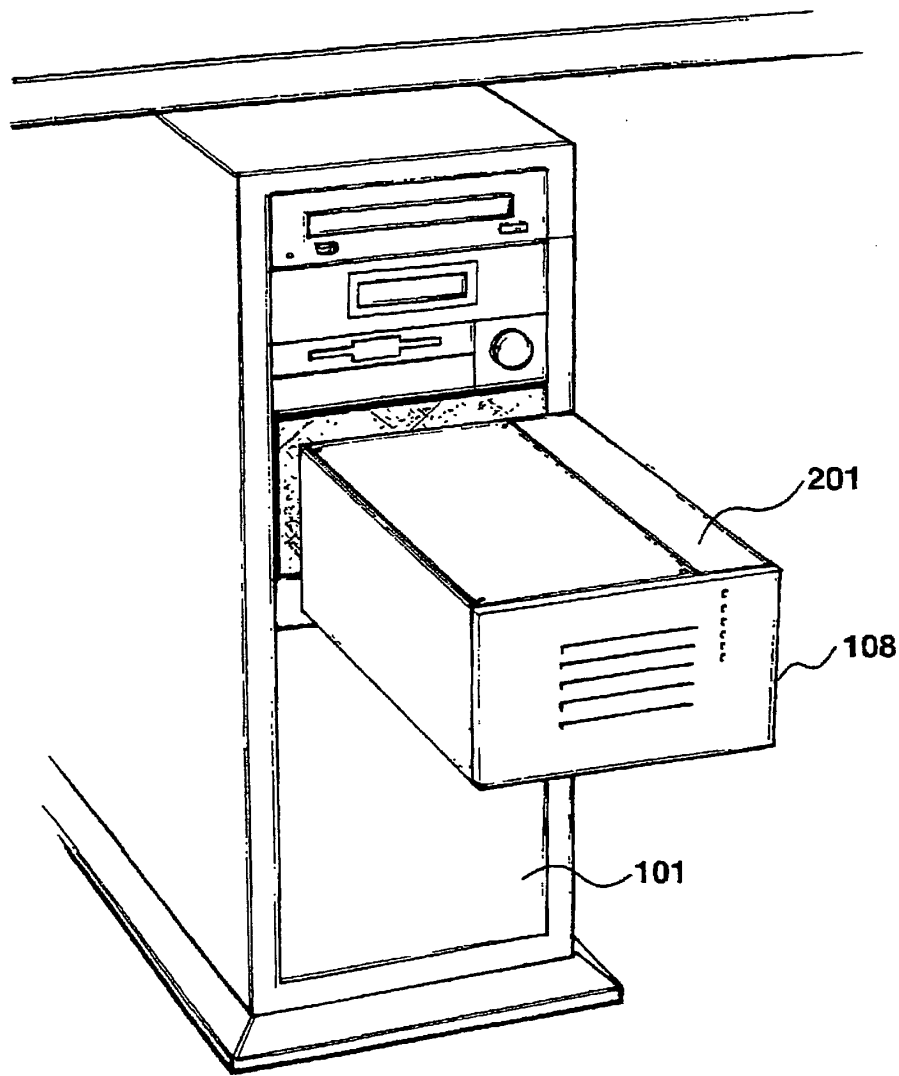

Figure 2

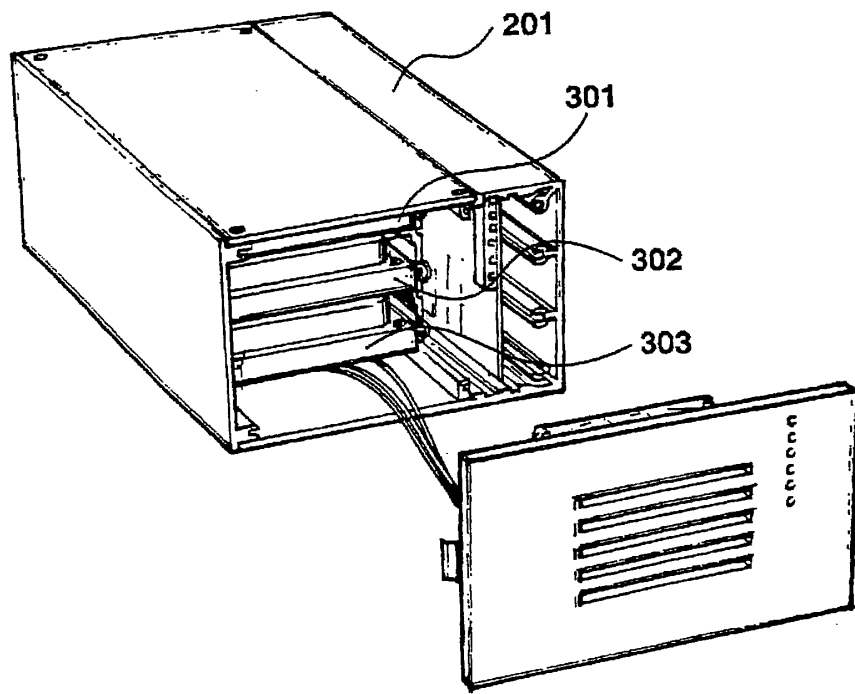

Figure 3

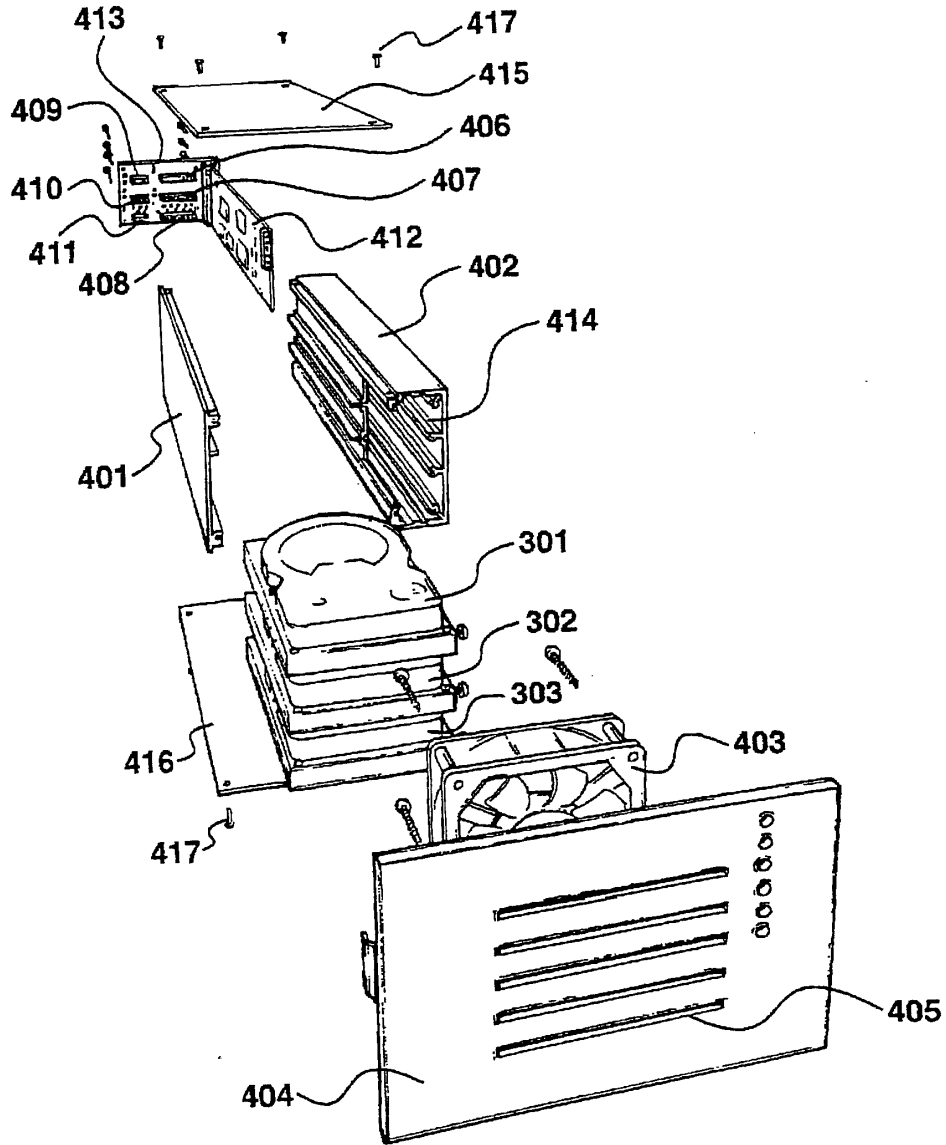

Figure 4

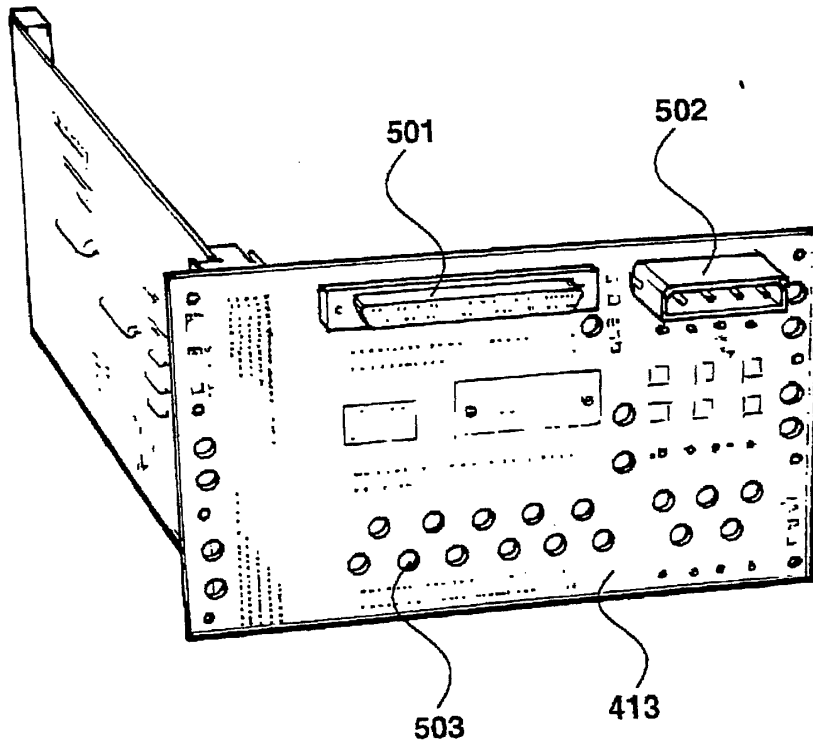

Figure 5

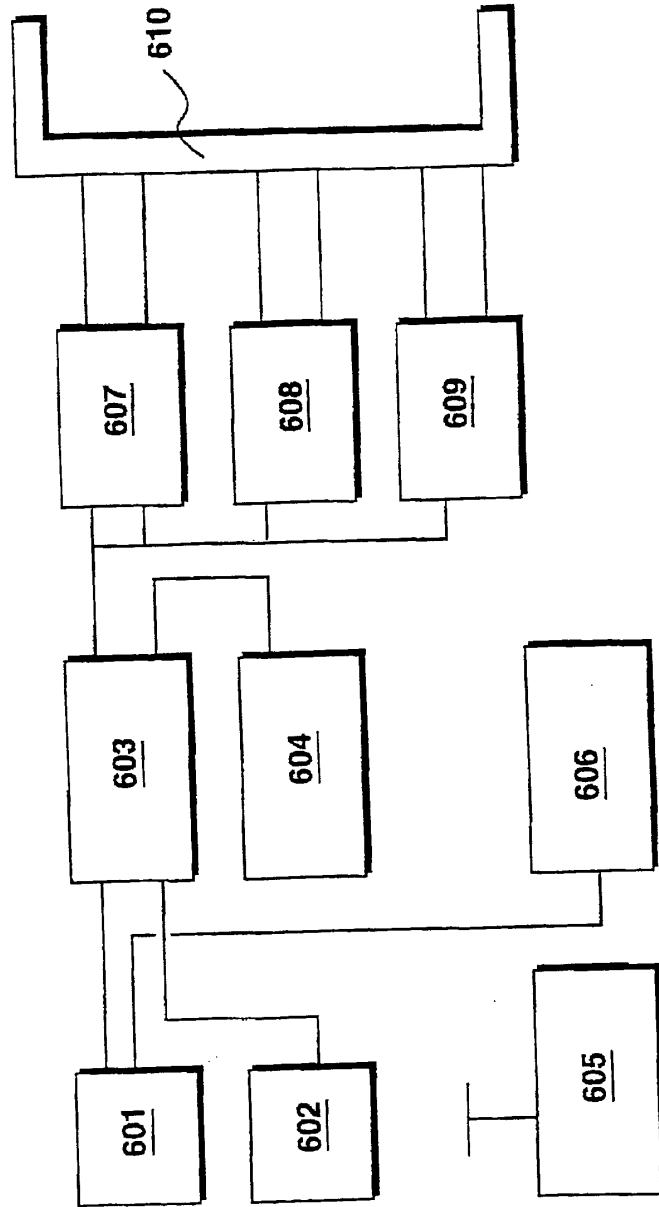

Figure 6

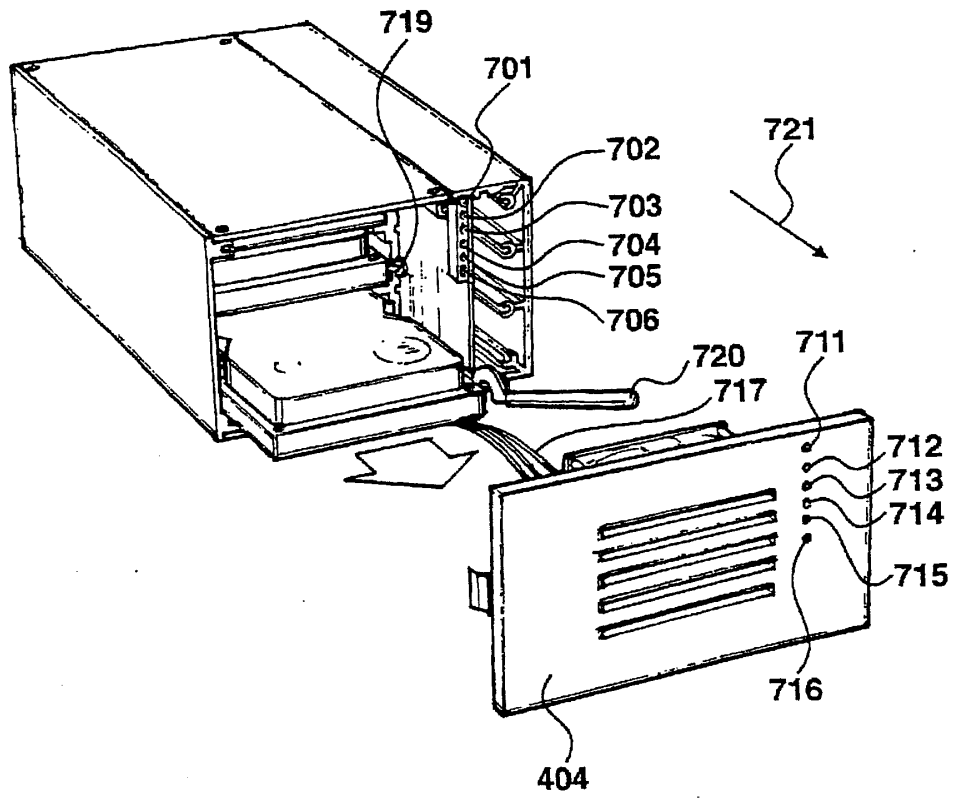

Figure 7

8/8

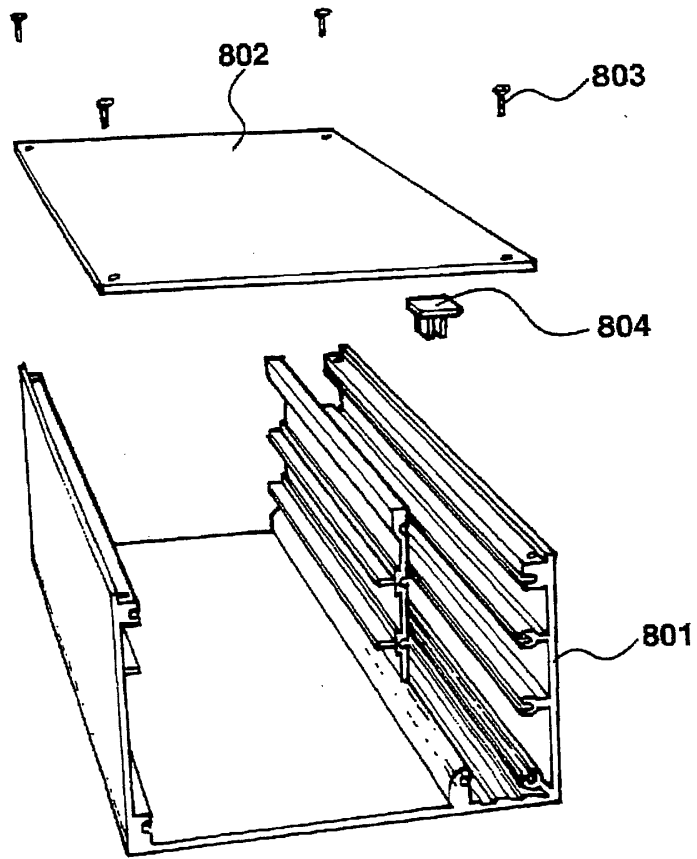

Figure 8

Data Storage

5 The present invention relates to an array of magnetic disks configured to store machine readable data in a protected way, such that data is recoverable in the event of disk failure.

10 Arrays configured to store machine readable data in a protected way are known and are often referred to as a redundant array of inexpensive disks, usually abbreviated to the acronym "RAID". Several RAID procedures are known and most of these share the approach of generating redundant data by an exclusive ORing process from which, in the event of any of the disks failing, all of the data can be reconstituted from the remaining operational disks.

15 When all of the disks are operational, the array is said to be working in its protected mode. In the event of one disk failure, the system may still remain operational, in that data may be read from the disks, but the data ceases to be protected and a further disk failure would result in data loss. With a single disk failure the system is said to be working in an unprotected mode at which point an operator would be advised that disk replacement is required and that the lost data needs to be reconstituted. Thus, a disk would be physically removed, replaced and then the lost data would be reconstituted on to the new disk.

20 As personal computer systems and workstations become more powerful, allowing more sophisticated software applications to be executed and the degree of data storage available in such systems increases, with disks containing several gigabytes of data now becoming widely used, a greater demand has been created for the installation of protected systems using disk redundancy. Complete RAID subsystems may be purchased for external connection but a problem with such known systems is that the cost can be very prohibitive. In many situations, the cost of such a RAID system

tends to be higher than the cost of a personal computer system. Thus, there is a requirement for providing RAID protection at reduced cost.

Personal computer systems are usually housed in desktop units or tower units having spare bays allowing additional disks to be received. Thus, it is possible for many hard disk drives to be included within a tower housing and additional interface cards may be provided if required. Thereafter, it is possible for the RAID calculations to be effected by the resident host CPU, such that the additional extra cost is quite modest. However, a major problem with such a configuration is that a significant processor overhead is required in order to perform the RAID calculations, resulting in a severe degradation in overall system performance.

According to a first aspect of the present invention, there is provided a plurality of data storage devices configured to store machine readable data in a protected way such that data is recoverable in the event of a single device failure, wherein the devices are housed for application directly into an existing disk bay for a computer; the devices are connectable to a disk interface as if they were a single conventional storage volume; and said devices are controlled by an operating system installed on a computer as if they were a single storage volume.

In a preferred embodiment, the disks are interfaced to an IDE connection and three disks may be received in respective IDE connections.

Preferably, the array presents a SCSI interface to a host computer and the array may be configured to be housed in two or more five and one quarter inch drive bays.

According to a second aspect of the present invention, there is provided a method of equipping a personal computer with a plurality of data storage devices configured as a redundant array by interfacing said devices to conventional five and one quarter inch drive bays, such that protected machine readable data is recoverable in the event of a single disk failure, comprising the steps of supporting the array within an existing disk bay for a

computer, connecting the array to the computer as if it were a single conventional computer disk; and controlling said drives by an operating system installed on a computer as if it were a single storage volume.

The invention will now be described by way of example only, with reference to the accompanying drawings, in which:

Figure 1 shows a personal computer system;

Figure 2 shows an array of disks being inserted into a computer system;

Figure 3 details the array shown in *Figure 2*;

Figure 4 shows an exploded view of the array identified in *Figure 3*;

Figure 5 shows a rear face view of the array back plane;

Figure 6 shows a circuit for implementing RAID calculations; and

Figure 7 illustrates the removal of a damaged disk from the array; and

Figure 8 shows an alternative embodiment for the extrusion identified in *Figure 4*.

A personal computer system is shown in *Figure 1* in which a main system tower 101 supplies visual information to a visual display unit 102 and receives manual commands via a keyboard 103. The main system tower houses a central processing unit, memory circuits and other standard associated electronics as is well known in the art. The personal computer system may be an IBM PC type system, a Mackintosh system or any other computer type equipment used for individual use, possibly in a networked configuration. Alternatively, the main system tower 101 may constitute a network server, possibly running an appropriate server operating system, such as Windows NT server.

Tower 101 includes conventional five and one quarter inch disk bays. Within these disk bays a plurality of devices have been mounted, including a three and a half inch floppy disk drive 105, a tape streamer 106, a CD ROM drive 107 and an array of magnetic disks 108, embodying the present invention.

Array 108 is detailed in *Figure 2* and is shown being installed into the main system tower 101. The array 108 of magnetic disks is configured to store machine readable data in a protected way such that data is recoverable in the event of a single disk failure. The array of disks is housed for application directly into an existing disk bay of a computer, such as the main system tower 101. The array is connectable to the computer as if it were a single conventional computer disk and the array is operated by an operating system installed on the computer as if it were a single disk.

Each empty drive bay is protected by a removable plastic cover and unit 107 locates within an aperture equivalent to the width of two bays, requiring the removal of two such covers. The array includes a housing 201, locatable within the two bay aperture and towards its rear includes conventional power and data connectors; such that the housing as a whole is connected to the main system tower using a conventional SCSI connection. Thus, the main system perceives the disk array as if it were a single disk and the operating system, executed by the main system, controls the operation of the array using equivalent commands to those required for the operation of a single storage volume.

The array 107 is detailed in *Figure 3* and contains a total of three IDE drives 301, 302 and 303. An exploded view of the array is illustrated in *Figure 4*, which shows each of the individual IDE drives 301, 302 and 303 being supported by aluminium extrusions, in the form of a left extrusion 401 and a right extrusion 402. These extrusions hold the disk drives 301, 302 and 303 firmly in place and facilitate the removal and replacement of individual disk drives when disk failure occurs.

Disk drives 301, 302 and 303 are located in relatively close proximity and in order to maintain preferred operational temperatures, an electric fan 403 is positioned between the front of the disk drives and a front housing 404. In this respect, the main front housing includes ventilation grilles 405.

Each IDE drive 301, 302 and 303 locates within a conventional IDE socket 406, 407, 408, in addition to respective power supply sockets 409, 410, 411. Thus, from the perspective of each IDE drive, the physical drives are located into sockets substantially similar to those found on an IDE bus of a standard computer system.

RAID calculations are performed within the device itself, using conventional hardware RAID circuitry mounted on circuit board 412, having electrical connections to the back plane circuit board 413. Right extrusion 402 defines a cavity 414, configured to receive circuit board 412. The extrusions 401 and 402 are held in position by an upper plate 415 and a lower plate 416, secured by appropriate bolts 417.

The rear face of back plane 413 is illustrated in *Figure 5*. The back plane includes a conventional SCSI socket 501 and a power supply socket 502. The array therefore presents itself to the main system as a single disk drive, requiring a single disk drive connection via SCSI interface 501.

Back plane 413 also includes rows of holes 503 to facilitate ventilation of the disks. Thus, cooling air is brought in through ventilation holes 405, blown between the disks 301, 302 and 303 and then exits through holes 503.

The circuit implemented on board 412 is illustrated diagrammatically in *Figure 6*. The circuit includes a central processing unit 601 which communicates with an input/output circuit 602 via a CPU bridge 603. In addition, operation of CPU 601 is controlled by a CPU mode select circuit 604. Power from the housing is directed to a three volt supply regulating circuit 605, arranged to supply power to operational circuits via supply rails.

The CPU 601 receives data relating to the operational environment from an environmental detecting circuit 606. This information may be received directly, as shown in *Figure 6*, or it may be directed via other control circuitry to allow combined environmental information to be returned to the CPU 601.

Further output circuitry includes IDE controllers 607 and 608 and a SCSI controller 609. These circuits communicate with the back plane sockets via a one hundred and eighty way connector 610.

5 Input/output circuit 602 supplies driving current to six LED's 701, 702, 703, 704, 705 and 706 shown in *Figure 7*. Each of these LED's is visible by means of respective holes 711, 712, 713, 714, 715 and 716 in the front panel 404. Each LED is a Hewlett Packard HSMF-C655 and actually includes a green LED and a red LED which may be operated independently.

10 LED 701 indicates the overall operational integrity of the system and primarily confirms that CPU 601 is operating correctly. Thus, when the system is fully operational, LED 701 is illuminated green. Alternatively, if faults have been detected within the controller, LED 701 is illuminated red.

15 LED 702 represents the environmental monitoring status and is primarily concerned with operational temperature. Environmental circuit 606 includes a temperature sensor and a fault condition is generated if this sensor detects that operational temperatures have become excessive. In addition, a tachometer is associated with fan 403 and a fault condition is generated if this detects that rotation of the fan has ceased. Malfunction of fan 403 represents a serious problem in that this could result in all three drives being permanently damaged such that no protection is offered by the RAID configuration. The system also detects the presence of appropriate voltages on voltage supply rails, as supplied by power supply unit 605 in addition to detecting appropriate terminator power on the SCSI bus.

20 When the supply rail voltages are correct, SCSI terminator power is correct, the fan is operational and the system is working at its optimal operational temperature, LED 702 is illuminated green. If the system encounters problems and diverges from its preferred operational characteristics, such a condition is detected and LED 702 is illuminated orange. Under these conditions, further operation of the system is permitted but warnings may be generated to the effect that a job should be closed

25

30

down and that the device should be investigated. If problems continue and the situation worsens, particularly if the operational temperature becomes very high, LED 702 is illuminated red. Under these conditions, power to the drives is removed and an error condition is generated such that further access to the drives is not permitted.

LED 703 indicates that the SCSI connection is fully operational by being illuminated green. Furthermore, when the SCSI bus is actually in use, LED 703 is illuminated orange.

LED's 704, 705 and 706 represents operational characteristics of the individual drives 301, 302 and 303 respectively. When the drives are operational, the LED's are illuminated green and then illuminated orange when the actual data transfer takes place. Furthermore, if a disk error is detected, to the effect that an individual disk has failed, its respective LED is illuminated red.

In response to a single disk failure, it is preferable for the system to be placed off-line and for the damaged disk to be replaced immediately so that the lost data may be reconstituted and the system returned to protected mode operation. In order to replace a disk, the front panel is removed, an operation facilitated by the front panel 404 being retained simply to the main housing by means of an interference connection. Having removed the front panel 404 it is restrained by wires 717 required for supplying electrical power to fan 403.

The disk drives include tapped holes towards their front-right corner and each of said tapped holes receives a threaded stud 719. Stud 719 allows its respective disk 301 to 303 to be removed by the application of a stud hook 720. Force is applied in the direction of arrow 721, thereby forcing the respective disk drive away from its IDE and data sockets, such as sockets 406 and 409 etc.

An alternative embodiment is illustrated in *Figure 8*. In this embodiment, side panels and a base panel are fabricated as a single

extrusion 801. The housing is then completed by the application of a top panel 802. The top panel 802 is secured to the lower extrusion 801 by means of bolts 803 and circuitry held within the extrusion is further secured by an adhesive clip 804.

Claims

- 5 1. A plurality of data storage devices configured to store machine readable data in a protected way such that data is recoverable in the event of a single device failure, wherein
 the devices are housed for application directly into an existing disk bay for a computer;
 the devices are connectable to a disk interface as if they were a single conventional storage volume; and
10 said devices are controlled by an operating system installed on a computer as if they were a single storage volume.
- 15 2. Data storage devices according to claim 1, wherein said storage devices are magnetic disk drives.
3. Data storage devices according to claim 2, wherein the magnetic disks are interfaced to an IDE connection.
- 20 4. Data storage devices according to claim 3, wherein three disks are received in respective IDE connections.
5. Data storage devices according to any of claims 1 to 3, wherein said devices present a SCSI interface to a host computer.
- 25 6. Data storage device according to any of claims 1 to 5, configured to be housed in two or more five and one quarter inch drive bays.
7. Data storage devices according to any of claims 1 to 6, including means for detecting when said devices are operating in non-ideal
30 conditions.

8. Data storage devices according to claim 7, including means for detecting when said devices are operating at excessive temperatures.

5 9. Data storage devices according to claim 7 or claim 8, including means for detecting non-operation of a cooling fan.

10 10. Data storage devices according to claim 7 or claim 8, including means for directly detecting an excessive operational temperature.

11. Data storage devices according to any of claims 7 to 10, including means for removing drive power to said devices upon detecting a non-ideal operating condition.

15 12. Data storage devices according to any of claims 1 to 11, including a detachable front panel and a cooling fan secured to said front panel, including ventilation openings arranged to direct a cooling air-stream between the individual devices.

20 13. A plurality of data storage devices according to any of claims 1 to 12, wherein said devices are connectable in a computer housing and the devices are controlled by the operating system of said computer.

25 14. A method of equipping a personal computer with a plurality of data storage devices configured as a redundant array by interfacing said devices to conventional five and one quarter inch drive bays, such that protected machine readable data is recoverable in the event of a single disk failure, comprising the steps of
supporting the array within an existing disk bay for a computer.

connecting the array to the computer as if it were a single conventional computer disk; and

controlling said drives by an operating system installed on a computer as if it were a single storage volume.

5

15. A method according to claim 14, wherein said data storage devices are magnetic disk drives.

10

16. A method according to claim 15, wherein said magnetic disk drives are interfaced to an IDE connection.

17. A method according to claim 16, wherein three disks are received in respective IDE connections.

15

18. A method according to any of claims 14 to 17, wherein said devices present a SCSI interface to a host computer.

20

19. A method according to any of claims 14 to 18, wherein said devices are housed in two or more five and one quarter inch drive bays.

20. A method according to any of claims 14 to 19, wherein non-ideal operating conditions for said devices are detected.

25

21. A plurality of data storage devices substantially as herein described with reference to the accompanying Figures.

22. A method of equipping a personal computer substantially as herein described with reference to the accompanying Figures.



Application No: GB 9820213.8
Claims searched: 1 to 22

Examiner: Julyan Elbro
Date of search: 4 January 1999

Patents Act 1977
Search Report under Section 17

Databases searched:

UK Patent Office collections, including GB, EP, WO & US patent specifications, in:
UK CI (Ed.Q): G5R (RGB, RB33, RAC); G4A (AES)
Int CI (Ed.6): G06F 11/10; G11B 20/18
Other: EDOC WPI

Documents considered to be relevant:

Category	Identity of document and relevant passage	Relevant to claims
X	EP 0795812 A1 HITACHI see figure 1 and pages 2-3.	1-20
X	EP 0717357 A2 SYMBIOSIS LOGIC see abstract and figure 2.	1-20
X	EP 0569313 A2 INTERNATIONAL BUSINESS MACHINES see abstract and figures 1 and 3.	1-20
X	EP 0569236 A2 COMPAQ see figure 2 and pages 2-4.	1-20
X	EP 0485110 A2 ARRAY TECHNOLOGY see abstract.	1-20
X	EP 0450801 A2 INTERNATIONAL BUSINESS MACHINES see abstract, column 22 line 34 to column 23 line 11, and column 27 lines 15-25.	1-20
X	WO 93/18455 A1 ARRAY TECHNOLOGY see abstract, figure 1, and page 10 lines 2-26.	1-20
X	WO 91/20076 A1 STORAGE TECHNOLOGY see abstract and figure 1.	1-20
X	WO 91/14982 A1 SF2 CORPORATION see abstract and figures 1 and 2.	1-20

X	Document indicating lack of novelty or inventive step	A	Document indicating technological background and/or state of the art.
Y	Document indicating lack of inventive step if combined with one or more other documents of same category.	P	Document published on or after the declared priority date but before the filing date of this invention.
&	Member of the same patent family	E	Patent document published on or after, but with priority date earlier than, the filing date of this application.



The
Patent
Office
13



INVESTOR IN PEOPLE

Application No: GB 9820213.8
Claims searched: 1 to 22

Examiner: Julyan Elbro
Date of search: 4 January 1999

Category	Identity of document and relevant passage	Relevant to claims
X	US 5651132 A HITACHI see abstract and figure 1.	1-20

X	Document indicating lack of novelty or inventive step	A	Document indicating technological background and/or state of the art.
Y	Document indicating lack of inventive step if combined with one or more other documents of same category.	P	Document published on or after the declared priority date but before the filing date of this invention.
&	Member of the same patent family	E	Patent document published on or after, but with priority date earlier than, the filing date of this application.

An Executive Agency of the Department of Trade and Industry

**This Page is Inserted by IFW Indexing and Scanning
Operations and is not part of the Official Record**

BEST AVAILABLE IMAGES

Defective images within this document are accurate representations of the original documents submitted by the applicant.

Defects in the images include but are not limited to the items checked:

- BLACK BORDERS
- IMAGE CUT OFF AT TOP, BOTTOM OR SIDES
- FADED TEXT OR DRAWING
- BLURRED OR ILLEGIBLE TEXT OR DRAWING
- SKEWED/SLANTED IMAGES
- COLOR OR BLACK AND WHITE PHOTOGRAPHS
- GRAY SCALE DOCUMENTS
- LINES OR MARKS ON ORIGINAL DOCUMENT
- REFERENCE(S) OR EXHIBIT(S) SUBMITTED ARE POOR QUALITY
- OTHER: _____

IMAGES ARE BEST AVAILABLE COPY.

As rescanning these documents will not correct the image problems checked, please do not report these problems to the IFW Image Problem Mailbox.

B2

JP1994301607A

1994-10-28

Bibliographic Fields

Document Identity

(19)【発行国】
 日本国特許庁(JP)
 (12)【公報種別】
 公開特許公報(A)
 (11)【公開番号】
 特開平6-301607
 (43)【公開日】
 平成6年(1994)10月28日

(19) [Publication Office]
 Japan Patent Office (JP)
 (12) [Kind of Document]
 Unexamined Patent Publication (A)
 (11) [Publication Number of Unexamined Application]
 Japan Unexamined Patent Publication Hei 6- 301607
 (43) [Publication Date of Unexamined Application]
 1994 (1994) October 28*

Public Availability

(43)【公開日】
 平成6年(1994)10月28日

(43) [Publication Date of Unexamined Application]
 1994 (1994) October 28*

Technical

(54)【発明の名称】
 マルチアクセスI/O制御方式
 (51)【国際特許分類第5版】
 G06F 13/00 351 B 7368-5B
 13/12 340 F 8133-5B
 【請求項の数】
 5
 【出願形態】
 OL
 【全頁数】
 10

(54) [Title of Invention]
MULTI ACCESS I/O CONTROL SYSTEM
 (51) [International Patent Classification, 5th Edition]
 G06F 13/00 351 B 7368-5B
 13/12 340 F 8133-5B
 [Number of Claims]
 5
 [Form of Application]
 OL
 [Number of Pages in Document]
 10

Filing

【審査請求】
 未請求
 (21)【出願番号】
 特願平5-86000
 (22)【出願日】
 平成5年(1993)4月13日

[Request for Examination]
 Unrequested
 (21) [Application Number]
 Japan Patent Application Hei 5- 86000
 (22) [Application Date]
 1993 (1993) April 13*

Parties

Applicants

(71)【出願人】

(71) [Applicant]

BEST AVAILABLE COPY

JP1994301607A

1994-10-28

【識別番号】

000005108

【氏名又は名称】

株式会社日立製作所

【住所又は居所】

東京都千代田区神田駿河台四丁目6番地

Inventors

(72)【発明者】

【氏名】

宇賀神 敦

【住所又は居所】

神奈川県海老名市下今泉810番地 日立製作所 オフィスシステム事業部内

Agents

(74)【代理人】

【弁理士】

【氏名又は名称】

鈴木 誠

Abstract

(57)【要約】

【目的】

複数の情報処理装置から複数の I/O デバイスへのアクセスを可能とする。

【構成】

複数の情報処理装置 20,30,40 とマルチアクセス制御装置 50 を FDDI10 に接続し、マルチアクセス制御装置 50 は、I/O デバイス 70,80,90 に SCSI 接続されている。

情報処理装置は、マルチアクセス制御装置へ FDDI フレームでアクセスする。

ネットワーク制御部 500 は、情報処理装置からのデータを FDDI インタフェースで送受信した後、プロトコル変換部 520 では、SCSI プロトコルに変換し、I/O デバイス制御部 510 を介して I/O デバイスをアクセスする。

[Identification Number]

000005108

[Name]

HITACHI LTD. (DB 69-054-1503)

[Address]

Tokyo Chiyoda-ku Kanda Surugadai 4-Chome 6

(72) [Inventor]

[Name]

*** Atsushi

[Address]

Kanagawa Prefecture Ebina City Shimoimaizumi 810address Hitachi office systems department *

(74) [Attorney(s) Representing All Applicants]

[Patent Attorney]

[Name]

Suzuki *

(57) [Abstract]

[Objective]

access to I/O device of plural is made possible from information processing apparatus of plural .

[Constitution]

information processing apparatus 20, 30, 40 and multi access control device 50 of plural are connected to FDDI10, the multi access control device 50 SCSI is connected to I/O device 70, 80, 90.

To multi access control device access it does information processing apparatus , with FDDIframe .

data from information processing apparatus transmission and reception after doing, in protocol conversion section 520,it converts network control unit 500, to SCSI protocol with FDDIinterface , through I/O device control unit 510,access it does I/O device .

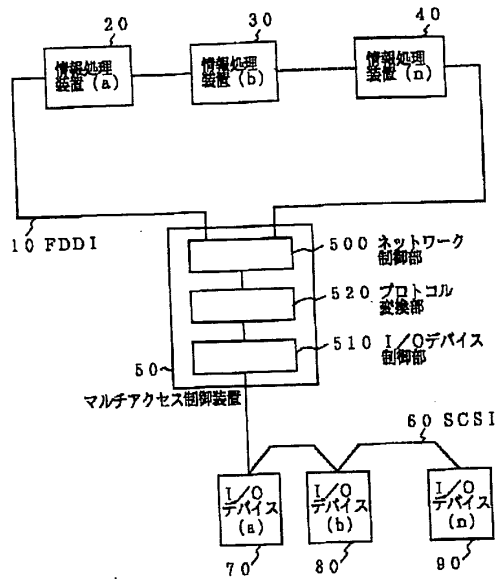

Claims

【特許請求の範囲】

【請求項 1】

ネットワークを介して複数の情報処理装置を接続したシステムにおいて、該ネットワークのインタフェース制御を行うネットワーク制御手段と、I/Oインタフェースを介して複数のI/Oデバイスを制御するI/Oデバイス制御手段と、該ネットワーク制御手段とI/Oデバイス制御手段のインタフェース変換を行うプロトコル変換手段からなるマルチアクセス制御手段を設け、前記複数の情報処理装置は該マルチアクセス制御手段を介して前記複数のI/Oデバイスにアクセスすることを特徴とするマルチアクセスI/O制御方式。

【請求項 2】

前記I/Oデバイス制御手段を前記I/Oデバイス内の制御部に内蔵することを特徴とする請求項1記載のマルチアクセスI/O制御方式。

【請求項 3】

前記複数の情報処理装置が実行した処理データを、前記マルチアクセス制御手段を介して前記所定のI/Oデバイスに格納し、該情報処理装置の障害発生時に予備の情報処理装置に切り

[Claim(s)]

[Claim 1]

Through network , through network control means and I/O interface which do interface control of said network in system which connects information processing apparatus of plural , the multi access control means which consists of protocol conversion means which converts I/O device control means and the said network control means and I/O device control means which control I/O device of plural interface providing. As for information processing apparatus of aforementioned plural through said multi access control means , in the I/O device of aforementioned plural access multi access I/O control system . which designates that it does as feature

[Claim 2]

multi access I/O control system . which is stated in Claim 1 which designates that the aforementioned I/O device control means is built in to control unit inside the aforementioned I/O device as feature

[Claim 3]

Treatment data which information processing apparatus of aforementioned plural executed, through aforementioned multi access control means , it houses in the aforementioned predetermined I/O device , changes to information processing

替え、該予備の情報処理装置は、前記処理データが格納された I/O デバイスを参照して処理を継続することを特徴とする請求項 1 記載のマルチアクセス I/O 制御方式。

【請求項 4】

前記各情報処理装置は、ローカル I/O デバイスを有し、該ローカル I/O デバイ스에記録される情報を、前記マルチアクセス制御手段を介して、前記情報処理装置に対応する I/O デバイ스에格納してバックアップすることを特徴とする請求項 1 記載のマルチアクセス I/O 制御方式。

【請求項 5】

前記 I/O インタフェースは、送信専用のインタフェースと受信専用のインタフェースから構成されていることを特徴とする請求項 1 記載のマルチアクセス I/O 制御方式。

Specification

【発明の詳細な説明】

【0001】

【産業上の利用分野】

本発明は、マルチアクセス I/O 制御方式に関し、特にネットワークを介して複数の情報処理装置を接続したシステムにおいて、複数の情報処理装置からアクセス可能な I/O デバイスの制御方式に関する。

【0002】

【従来技術】

I/O デバイスを複数の処理装置によって共用する技術として、例えば、特開平 4-196737 号公報に記載された方式がある。

この方式においては、1 台の保守用コンソールを複数のホストコンピュータで共有するもので、ホストコンピュータからの受信データをバッファリングした後、コントロールユニットに通知し、該コントロールユニットはホスト選択用のスイッチを設定し、選択されたホストのデータを保守用コンソールに出力する。

【0003】

【発明が解決しようとする課題】

しかしながら、上記した技術は、各ホストインタフェース毎に独立にバッファを設けているので、ハ

apparatus of preparatory at time of damage of said information processing apparatus , as for information processing apparatus of said preparatory , referring to I/O device where aforementioned treatment data is housed, the multi access I/O control system . which it states in Claim 1 which designates that it continues treatment as feature

【Claim 4】

information which aforementioned each information processing apparatus , possesses local I/O device , is recorded to said local I/O device , through aforementioned multi access control means , housing in I/O device which corresponds to aforementioned information processing apparatus , backup the multi access I/O control system . which is stated in Claim 1 which designates thing which is done as feature

【Claim 5】

As for aforementioned I/O interface , from interface of transmission dedicated and interface of reception dedicated configuration multi access I/O control system . which is stated in Claim 1 which designates that it is done as feature

【Description of the Invention】

【0001】

【Field of Industrial Application】

this invention regards multi access I/O control system , through especially network , from the information processing apparatus of plural it regards control system of accessible I/O device in system which connects information processing apparatus of plural .

【0002】

【Prior Art】

There is a system which is stated in for example Japan Unexamined Patent Publication Hei 4- 196737 disclosure as technology which shares I/O device with processing unit of plural .

Regarding this system , being something which shares console for the conservation of 1 with host computer of plural table , buffering after doing, it notifies received information from host computer to control unit , said control unit sets the Switch for host selection, outputs data of host which is selected to console for conservation .

【0003】

【Problems to be Solved by the Invention】

But, because technology which was inscribed in each every host interface has provided buffer in independence, amount of

ードウェア量が多くなり、また、ホスト選択スイッチのような固有のハードウェアを必要とし、さらに、ホスト数に相当する数のホストインタフェースコネクタを必要とするので、接続するホストが多くなると装置全体が大型化するとともに、複数台のホストに対して1台のコンソールを接続した構成しか採ることができないという欠点があった。

[0004]

本発明の目的は、複数の情報処理装置から複数の I/O デバイスへのアクセスを可能とするマルチアクセス I/O 制御方式を提供することにある。

[0005]

【課題を解決するための手段】

前記目的を達成するために、請求項1記載の発明では、ネットワークを介して複数の情報処理装置を接続したシステムにおいて、該ネットワークのインタフェース制御を行うネットワーク制御手段と、I/O インタフェースを介して複数の I/O デバイスを制御する I/O デバイス制御手段と、該ネットワーク制御手段と I/O デバイス制御手段のインタフェース変換を行うプロトコル変換手段からなるマルチアクセス制御手段を設け、前記複数の情報処理装置は該マルチアクセス制御手段を介して前記複数の I/O デバイスにアクセスすることを特徴としている。

[0006]

請求項2記載の発明では、前記 I/O デバイス制御手段を前記 I/O デバイス内の制御部に内蔵することを特徴としている。

[0007]

請求項3記載の発明では、前記複数の情報処理装置が実行した処理データを、前記マルチアクセス制御手段を介して前記所定の I/O デバイスに格納し、該情報処理装置の障害発生時に予備の情報処理装置に切り替え、該予備の情報処理装置は、前記処理データが格納された I/O デバイスを参照して処理を継続することを特徴としている。

[0008]

請求項4記載の発明では、前記各情報処理装置は、ローカル I/O デバイスを有し、該ローカル I/O デバイスに記録される情報を、前記マルチアクセス制御手段を介して、前記情報処理装置に

hardware to become many, in addition, to need hardware of peculiar like host selection switch, because furthermore, host interface connector of a quantity which is suitable to quantity of host are needed, when host which is connected becomes many as device entirety does scale-up, There was a deficiency that only configuration which connects console of 1 vis-a-vis host of plural table it is possible to take.

[0004]

objective of this invention is to offer multi access I/O control system which makes access to I/O device of plural possible from information processing apparatus of plural .

[0005]

[Means to Solve the Problems]

In order to achieve aforementioned objective , with invention which is stated in Claim 1, through network , through network control means and the I/O interface which do interface control of said network in system which connects the information processing apparatus of plural , multi access control means which consists of protocol conversion means which converts I/O device control means and said network control means and I/O device control means which control I/O device of plural interface providing, information processing apparatus of aforementioned plural through said multi access control means , has designated that access it does as feature in I/O device of the aforementioned plural .

[0006]

With invention which is stated in Claim 2, it designates that aforementioned I/O device control means is built in to control unit inside the aforementioned I/O device as feature.

[0007]

With invention which is stated in Claim 3, treatment data which information processing apparatus of aforementioned plural executed, through the aforementioned multi access control means , it houses in aforementioned predetermined I/O device , change to information processing apparatus of preparatory at time of damage of said information processing apparatus , the information processing apparatus of said preparatory referring to I/O device where aforementioned treatment data is housed, has designated that it continues treatment as feature.

[0008]

With invention which is stated in Claim 4, aforementioned each information processing apparatus , it possesses local I/O device , information which is recorded to the said local I/O device , through aforementioned multi

対応する I/O デバイスに格納してバックアップすることを特徴としている。

[0009]

請求項 5 記載の発明では、前記 I/O インタフェースは、送信専用のインタフェースと受信専用のインタフェースから構成されていることを特徴としている。

[0010]

【作用】

複数の情報処理装置とマルチアクセス制御装置が FDDI に接続され、マルチアクセス制御装置は、I/O デバイスに SCSI 接続されている。

マルチアクセス制御装置は、ネットワーク制御部とプロトコル変換部と I/O デバイス制御部から構成されている。

情報処理装置は、マルチアクセス制御装置へ FDDI フレームでアクセスする。

ネットワーク制御部は、情報処理装置からのデータを FDDI インタフェースで送受信した後、プロトコル変換部では、SCSI プロトコルに変換し、I/O デバイス制御部を介して I/O デバイスをアクセスする。

これにより、従来の I/O デバイスに何ら変更を加えることなく、マルチアクセス制御装置を付加するのみで、複数の情報処理装置から複数の I/O デバイスを制御することができる。

[0011]

【実施例】

以下、本発明の一実施例を図面を用いて具体的に説明する。

図 1 は、本発明の一実施例に係るシステム構成図である。

本発明のシステムは、複数の情報処理装置 20、30、40 とマルチアクセス制御装置 50 が FDDI(Fiber Distributed Data Interface)10(LAN) に接続されて構成されている。

[0012]

FDDI10 に接続された情報処理装置 20、30、40 は、マルチアクセス制御装置 50 へ FDDI フレームでアクセスする。

マルチアクセス制御装置 50 は、FDDI インタフェース制御を行うネットワーク制御部 500 と、

access control means , housing in I/O device which corresponds to aforementioned information processing apparatus , it designates that backup it does as feature.

[0009]

With invention which is stated in Claim 5, as for the aforementioned I/O interface , it designates that configuration it is done as feature from interface of transmission dedicated and interface of thereception dedicated .

[0010]

[Working Principle]

information processing apparatus and multi access control device of plural are connected by FDDI, the multi access control device SCSI is connected to I/O device .

multi access control device configuration is done from network control unit and protocol conversion section and I/O device control unit .

To multi access control device access it does information processing apparatus , with FDDI frame .

data from information processing apparatus transmission and reception after doing, in protocol conversion section, it converts network control unit , to SCSI protocol with FDDI interface , through I/O device control unit , access it does I/O device .

Because of this, multi access control device is added only, can control I/O device of the plural from information processing apparatus of plural without adding what modification to conventional I/O device .

[0011]

[Working Example(s)]

Below, one Working Example of this invention is explained concretely making use of drawing .

Figure 1 is system diagram which relates to one Working Example of this invention .

system of this invention is done, information processing apparatus 20, 30, 40 and multi access control device 50 of plural FDDI (Fiber Distributed data interface) being connected by 10 (LAN) , configuration .

[0012]

To multi access control device 50 access it does information processing apparatus 20, 30, 40 which is connected to the FDDI10, with FDDI frame .

multi access control device 50 configuration is done from protocol conversion section 520 which converts I/O device

SCSI60 に接続されている I/O デバイス 70,80,90(例えば、ハードディスクなどの記憶媒体や回線などの通信手段)の制御を行う I/O デバイス制御部 510 と、FDDI プロトコル及び SCSI プロトコルのインタフェース変換を行うプロトコル変換部 520 から構成されている。

【0013】

図 2 は、マルチアクセス制御装置 50 のブロック構成図である。

マルチアクセス制御装置 50 において、ネットワーク制御部 500 と、I/O デバイス制御部 510 と、RAM523 と、アクセス制御部 524 は I/O バス 525 によって接続され、プロセッサ 521 と、ROM522 と、アクセス制御部 524 はプロセッサバス 526 によって接続されている。

【0014】

プロトコル変換を行うためのプログラムは、ROM522 に格納され、プロセッサ 521 上で動作する。

本実施例では、I/O バス 525 の使用率を下げるためにプロセッサバス 526 を設けているが、情報処理装置 20、30、40 からのアクセス頻度が低い場合には、I/O バスとプロセッサバスを同一バスにして構成してもよい。

【0015】

アクセス制御部 524 は、ネットワーク制御部 500 または I/O デバイス制御部 510 からプロセッサ 521 への割込み制御を行うと共にプロセッサ 521 から RAM523、ネットワーク制御部 500、I/O デバイス制御部 510 へのアクセス制御並びにネットワーク制御部 500、I/O デバイス制御部 510 から RAM523 へのアクセス制御を行っている。

【0016】

ROM522 には、プログラムの他に FDDI の MAC(Media Access Control)アドレスを格納する。

RAM523 は、データ送信及び受信用のバッファとして使用するほかに、ネットワーク制御部 500、I/O デバイス制御部 510 への制御を行うためのディスクリプタ領域として使用する。

また、マルチアクセス制御装置内のステータス管理や I/O デバイス毎の管理等のためにテーブルとして使用する。

【0017】

図 3 は、情報処理装置からマルチアクセス制御装置への制御フレームのフォーマットを示す図

control unit 510 and FDDI protocol and SCSI protocol which control I/O device 70, 80, 90 (for example hard disk or other storage media and circuit or other communication means) which is connected to network control unit 500 and SCSI 60 which do FDDI interface control interface .

【0013】

Figure 2 is block diagram of multi access control device 50.

In multi access control device 50, network control unit 500 and I/O device control unit 510 and RAM 523 and access control section 524 are connected with I/O bus 525, processor 521 and ROM 522 and access control section 524 are connected with processor bus 526.

【0014】

program in order to do protocol conversion is housed in ROM 522, operates on processor 521.

With this working example, processor bus 526 is provided in order to lower usage of I/O bus 525, but when access frequency from information processing apparatus 20, 30, 40 is low, configuration it is possible to do with I/O bus and processor bus as same bus .

【0015】

access control section 524, as interruption control to processor 521 is done from network control unit 500 or I/O device control unit 510, from processor 521 does access control to RAM 523 from access control and network control unit 500, I/O device control unit 510 to RAM 523, network control unit 500, I/O device control unit 510.

【0016】

In ROM 522, MAC (Media access control)-address of FDDI is housed to other than program .

Besides you use as buffer for data transmission and reception, you use RAM 523, as [disukuriputa] region in order to control to network control unit 500, I/O device control unit 510.

In addition, you use management or other for every status management and I/O device inside multi access control device as table .

【0017】

Figure 3 is figure which shows format of control frame to multi access control device from information processing

である。

図 3 において、FDDI ヘッダ 100(ANSI 標準)に SNAP ヘッダ 110、IP ヘッダ 120、TCP ヘッダ 130(全て Request For Comment で規定されている)、データ 140 を付加し制御を行う。

【0018】

情報処理装置 20,30,40 とマルチアクセス制御装置 50 との間の送達確認及び順序制御は、TCP(Transmission Control Protocol)により行う。

【0019】

データ 140 は、制御ブロック 1410、1450 と送信 I/O データ 1460 から構成されていて、制御ブロックは、1 乃至複数のブロックからなる。

また、送信 I/O データ 1460 は付加してもよいし、あるいは付加しなくてもよいが、最大フレーム長は、FDDI 規格に準拠する必要がある。

【0020】

制御ブロック 1410、1450 は 28 バイトから構成される。

制御ブロック 1410 において、制御ブロック長 1411 は、2 バイトのフィールドであり、制御ブロックの総バイト長を示す。

コマンドチェインビット 1412 は、1 ビットからなり、異なるコマンドの制御ブロックが連続しているか否かを示す。

“0”の時はコマンドチェインなし、“1”の時はコマンドチェインありを示す。

【0021】

デバイス ID1413 は、2 バイトのフィールドであり、SCSI_ID 4 ビット、LUN(Logical Unit Number) 4 ビット、拡張 LUN 8 ビットから構成される。

CDB フォーマット 1414 は、5 ビットのフィールドである。

CDB は、6 バイト、10 バイト、12 バイトがあるのでその種別を示している。

“0”が 6 バイト、“1”が 10 バイト、“2”が 12 バイトを示す。

【0022】

不正長抑止ビット 1415 は、1 ビットのフィールドである。

リード要求と実際の読みだしデータ長が異なってもエラー報告しないためのビットである。

apparatus .

In Figure 3 , SNAPheader 110 , IP header 120, TCP header 130 (Being stipulated with all Request For Comment, it is) , it adds data 140 to FDDIheader 100 (ANSIstandard) andcontrols.

【0018】

It does sending verification and order control between information processing apparatus 20, 30, 40 and multi access control device 50, with TCP (transmission Control protocol) .

【0019】

As for data 140, configuration being done from control block 1410, 1450 and thetransmission I/O data 1460, as for control block , it consists of block of 1 to plural .

In addition, it is possible to add transmission I/O data 1460 it is notnecessary, and, or to add, but maximum frame length has necessity to conformto FDDIstandard .

【0020】

control block 1410, 1450 configuration is done from 28 byte .

In control block 1410, control block length 1411, with field of 2 byte , shows theentire byte length of control block .

command chain bit 1412 consists of 1 bit , shows whether or not which control block of the different command is continual.

When " 0 " being, there is a command chain and shows time of command chain none , *1'' .

【0021】

device ID1413, with field of 2 byte , SCSI_ID 4bit , LUN (Logical Unit Number) configuration is donefrom 4 bit , extended LUN 8bit .

CDBformat 1414 is field of 5 bit .

Because CDB are 6 byte , 10byte , 12byte , type has been shown.

" 0 " 6 byte , *1'' 10 byte , *2* 12 byte are shown.

【0022】

Illegitimate long control bit 1415 is field of 1 bit .

read request and actual it starts reading and data length differs and error it is a bit because it does not report.

"1"のときエラー報告せず、"0"のときエラー報告する。

【0023】

終了報告ビット1416は、1ビットのフィールドである。

"1"のとき処理終了を終了報告ブロック(図4)で報告する。

"0"の時は報告しない。

【0024】

コマンド1421は、8ビットのフィールドである。

データ受信、データ送信、マルチアクセス制御装置50に対する指示などを示す。

SCSI NO.1422は、8ビットのフィールドである。

マルチアクセス制御装置50内で複数のSCSIを制御する場合に、どのSCSIかを識別するための情報である。

シーケンスNO.1420は、16ビットのフィールドである。

情報処理装置20,30,40からの要求とマルチアクセス制御装置50からの終了報告を対応させるための情報である。

【0025】

データカウント1418は、4バイトのフィールドであり、送信または受信するデータ長を示す。

CDB1419は、本実施例では10バイトであり、SCSI規格に準拠したCDBを格納する。

【0026】

図4は、マルチアクセス制御装置から情報処理装置への終了フレームのフォーマットを示す図である。

図において、FDDIヘッダ100、SNAPヘッダ110、IPヘッダ120、TCPヘッダ130は、前述したものと同様である。

データ140は、終了報告ブロック1470と受信I/Oデータ1480から構成されている。

【0027】

終了報告ブロック1470は、16バイトから構成されている。

終了報告ブロック長1471は、16ビットのフィールドであり、終了報告ブロックの総バイト数を示す。

終了報告チェインビット1472は、1ビットのフィールドであり、終了報告が複数ある場合に"1"を

" At time of 1 '' error it does not report, " when 0 "being, error it reports.

[0023]

End report bit 1416 is field of 1 bit .

" At time of 1 '' treatment end is reported with endreport block (Figure 4).

When " 0 " being, it does not report.

[0024]

command 1421 is field of 8 bit .

data reception , data transmission and indication etc for multi access control device 50 are shown.

SCSI NO.1422 is field of 8 bit .

When SCSI of plural is controlled inside multi access control device 50, it is a information in order to identify which SCSI .

sequence NO.1420 is field of 16 bit .

It is a information because end report from multi access control device 50 it corresponds withrequest from information processing apparatus 20, 30, 40.

[0025]

data count 1418 with field of 4 byte , shows data length which itransmits or receives, or.

CDB1419 with this working example with 10 byte , houses CDB whichconforms to SCSI standard .

[0026]

Figure 4 is figure which shows format of end frame to the information processing apparatus from multi access control device .

In figure, FDDIheader 100, SNAPheader 110 , IP header 120, TCP header 130 is similar to those which are mentionedearlier.

data 140 configuration is done from end report block 1470 and thereception I/O data 1480.

[0027]

End report block 1470 configuration is done from 16 byte .

End report block length 1471, with fee jp11 of 16 bit , shows theentire number of bytes of end report block .

End report chain bit 1472, when with field of 1 bit , end report is a plural , " sets 1 '' ;

設定する。

【0028】

ステータス 1474 は、16 ビットのフィールドである。

このフィールドは、エラーの軽重を示すシビリティビット4ビット、エラーステータスフィールド12ビットから構成される。

SAVE DMA カウント 1473 は、4 バイトのフィールドであり、データカウント 1418 と実際に処理完了したバイト数の差分を示す。

例えば、データカウント 1418 が 1000 バイトで、実際に処理したデータが 1000 バイトの場合、該フィールドは、0 となる。

【0029】

図 5 は、情報処理装置 20、情報処理装置 30 からマルチアクセス制御装置 50 へのアクセスシーケンスを示す。

以下、情報処理装置から I/O デバイスへデータを書き込む場合の実施例の動作を説明する。

【0030】

情報処理装置 20 からマルチアクセス制御装置 50 へデータ書き込み指示を図 3 に示すフレームフォーマットで送信する。

ネットワーク制御部 500 はフレームを受信し、プロトコル変換部 520 から予め渡された RAM523 上のバッファにデータを格納する。

ネットワーク制御部 500 は、データ格納後、割込みをアクセス制御部 524 を介してプロセッサ 521 に通知する。

【0031】

情報処理装置 20 からのデータ書き込み指示の後、情報処理装置 30 からマルチアクセス制御装置 50 へ、データ書き込み指示を図 3 に示すフレームフォーマットで送信する。

ネットワーク制御部 500 はフレームを受信しプロトコル変換部 520 から予め渡された RAM523 上のバッファにデータを格納する。

ネットワーク制御部 500 は、データ格納後、割込みをアクセス制御部 524 を介してプロセッサ 521 に通知する。

但し、情報処理装置 20 からの処理が先であるのでその処理が終了するまで処理保留となる。

is a plural , " sets 1 '' .

[0028]

status 1474 is field of 16 bit .

this field shows light heavy of error , [shibiritibitto] configuration it is done from4 bit , error status field 12bit .

SAVE DMA count 1473, with field of 4 byte , shows difference of number of bytes which process end is done in data count 1418 and fact.

for example data count 1418 being 1000 byte , when data which was treated actuallyis 1000 byte , said field becomes with 0.

[0029]

Figure 5 shows access sequence to multi access control device 50 from information processing apparatus 20, information processing apparatus 30.

Below, operation of Working Example when from information processing apparatus data is writtento I/O device is explained.

[0030]

From information processing apparatus 20 to multi access control device 50 it transmits with frame format which shows data writing indication in Figure 3 .

network control unit 500 receives frame , houses data in buffer on the RAM 523 which is beforehand transferred from protocol conversion section 520.

network control unit 500, after data storage , through access control section 524, notifies theinterruption to processor 521.

[0031]

After data writing indication from information processing apparatus 20, from information processing apparatus 30 to the multi access control device 50, it transmits with frame format which shows data writing indication in Figure 3 .

network control unit 500 receives frame and houses data in buffer on the RAM 523 which is beforehand transferred from protocol conversion section 520.

network control unit 500, after data storage , through access control section 524, notifies theinterruption to processor 521.

However, because treatment from information processing apparatus 20 is ahead, until thattreatment ends, it becomes treatment reservation .

【0032】

割り込みを受けたプロトコル変換部 520 は、受信したフレームのヘッダを解析し TCP、IP(Internet Protocol)処理を行う。

その後、制御ブロック 1410 を解析する。

フォーマットが正常ならば SCSI NO.1422、デバイス ID1413 が示す SCSI に対してコマンドを発行する。

コマンドの発行は、RAM523 上のディスクリプタに CDB を格納した後、I/O デバイス制御部 510 内のハードウェアレジスタに起動をかけることにより行う。

コマンドを受けた I/O デバイス制御部 510 は、SCSI 規格に従ってアービトレーション、セレクション、メッセージ、コマンドフェーズを遷移した後、情報処理装置 20 によって指定された例えば I/O デバイス 70 に対してデータ転送を行う。

【0033】

この時のデータ転送は、DMA(Direct Memory Access)で行う。

データ転送終了後、I/O デバイス 70 からステータス及びコマンドコンプリートが送られてくる。

これを受けた、I/O デバイス制御部 510 はプロセッサ 521 への割り込みをアクセス制御部 524 を介して通知する。

【0034】

割り込みを受けたプロセッサ 521 は、RAM523 に格納されているステータスを解析する。

その後、図 4 に示した終了報告ブロック、IP ヘッダ、TCP ヘッダ、SNAP ヘッダを RAM523 上に作成し、ネットワーク制御部 500 内のハードウェアレジスタに送信指示を書き込む。

これを受けたネットワーク制御部 500 は、FDDI プロトコルに従って終了報告を情報処理装置 20 に送信する。

【0035】

情報処理装置 20 の処理が終了後、情報処理装置 30 の処理を行う。

その動作は、前述した情報処理装置 20 の場合と同様であるので、説明は省略する。

【0036】

図 6 は、マルチアクセス制御装置と I/O デバイスを一体化させた場合の他の実施例の構成を示

【0032】

protocol conversion section 520 which receives interruption analyzes the header of frame which is received and does TCP , IP (internet protocol) treatment.

After that, control block 1410 is analyzed.

command is issued format vis-a-vis SCSI which normal mule SCSI NO.1422, device ID1413 shows.

It issues command , after housing CDB in [disukuriputa] on RAM 523,by making starting on hardware register inside I/O device control unit 510.

I/O device control unit 510 which receives command , following to SCSI standard , does the data transfer transition after doing arbitration , selection , message , command phase , vis-a-vis for example I/O device 70 which isappointed with information processing apparatus 20.

【0033】

It does data transfer at time of this , with DMA (direct memory access) .

After data transfer ending, stator and [komandokonpuriito] are sent from I/O device 70.

This was received, I/O device control unit 510 through access control section 524, notifies theinterruption to processor 521.

【0034】

processor 521 which receives interruption analyzes status which ishoused in RAM 523.

After that, end report block , IP header , TCP header , SNAPheader which is shown in Figure 4 is drawup on RAM 523, transmission indication is written to hardware register inside network control unit 500.

network control unit 500 which receives this, following to FDDIprotocol , transmits endreport to information processing apparatus 20.

【0035】

Treatment of information processing apparatus 20 after ending, treats information processing apparatus 30.

Because operation is similar to case of information processing apparatus 20 which ismentioned earlier, it abbreviates explanation.

【0036】

Figure 6 is figure which shows configuration of other Working Example when multi access control device and I/O

す図である。

すなわち、一体化によって、I/O デバイス内の制御部(SCSI コントローラ)が I/O デバイス制御部 510 を肩代わりし、従って、図 2 に示す I/O デバイス制御部 510 を設ける必要がなくなり、直接 I/O デバイス内の I/O 制御部 700 に制御ブロックを渡す処理方式を採ることになる。

[0037]

図 7 は、現用系情報処理装置から予備系情報処理装置への切替えを行う場合の他の実施例の構成を示す図である。

現用系情報処理装置 21,22 は、処理を実行する場合に、マルチアクセス制御装置 50 を介して、任意の I/O デバイス 70 内に引継ぎ情報 71 を格納処理する。

そして、現用系情報処理装置 21,22 に障害が発生したとき、予備系情報処理装置 23 は I/O デバイス 70 内の引継ぎ情報 71 を読み出して、処理を続行する。

[0038]

図 8 は、情報処理装置を I/O デバイスによってバックアップする場合の他の実施例の構成を示す図であり、各情報処理装置はローカル I/O デバイスを備えた構成を採っている。

[0039]

各情報処理装置 20,30,40 は、それぞれローカル I/O デバイス 201, 301, 401 にデータを書き出すとともに、情報処理装置 20 は、例えば I/O デバイス 70 に、情報処理装置 30 は I/O デバイス 80 に、情報処理装置 40 は I/O デバイス 90 にそれぞれデータを書き出し、データをバックアップする。

この書き出しは、前述した図 5 のシーケンスによって行う。

[0040]

図 9 は、マルチアクセス制御装置が 2 本の SCSI を制御する他の実施例の構成を示す。

この実施例では、一つのマルチアクセス制御装置から 2 本の SCSI を制御し、一方を送信専用とし、他方を受信専用に行っている。

[0041]

図において、SCSI コントローラ 511 は送信専用

device are unified.

With namely, unification, control unit (SCSI controller) inside I/O device shoulder doesto substitute I/O device control unit 510, therefore, necessity to provide I/O device control unit 510 which is shown in Figure 2 is gone, means to take treatment system whichdirectly transfers control block to I/O control unit 700 inside I/O device .

[0037]

Figure 7 is figure which shows configuration of other Working Example when changeover to preparatory information processing apparatus is done from current system information processing apparatus .

When treatment is executed, through multi access control device 50, it takes over the current system information processing apparatus 21, 22, inside I/O device 70 of option and it houses treats information 71.

When and, fault occurs in current system information processing apparatus 21, 22, preparatory information processing apparatus 23 takingover information 71 inside I/O device 70 reading *, continues treatment.

[0038]

As for Figure 8 , information processing apparatus in figure which shows configuration of theother Working Example when backup it does, as for each information processing apparatus configuration whichhas local I/O device is taken with I/O device .

[0039]

As for each information processing apparatus 20, 30, 40, as data is written out in respective local I/O device 201, 301, 401, as for information processing apparatus 20, in for example I/O device 70, as for information processing apparatus 30 in I/O device 80,information processing apparatus 40 it writes out data respectively in I/O device 90, data backup does.

It writes out this , with sequence of Figure 5 which is mentionedearlier.

[0040]

Figure 9 shows configuration of other Working Example where multi access control device controls SCSI of 2.

With this Working Example , it controls SCSI of 2 from multi access control device of the one , on one hand makes transmission dedicated , designates other as reception dedicated .

[0041]

In figure, as for SCSI controller 511 with transmission

であり、SCSI コントローラ 512 は受信専用である。

そして、I/O デバイス 70 への書き込みは SCSI コントローラ 511 を用い、I/O デバイス 70 からの読み出しは SCSI コントローラ 512 を用いる。

ただし、I/O デバイスに対するコマンドは送信受信にかかわらず全て SCSI コントローラ 511 で行う。

[0042]

本実施例の方式は、I/O デバイスが 1 台の場合に特に効果的である。

つまり、デバイスが 1 台に特定できるので、アービトレーション、セレクションを最初の 1 回のみ行い、その後のアクセス時にはアービトレーション、セレクションを省略することが出来る。

従って、SCSI のフェーズ遷移でコマンドコンプリート送信後、バスフリーすることなく、再びコマンドフェーズにすることができるので、高速なデータアクセスが可能となる。

[0043]

なお、本実施例は上記したものの他に、ブロードキャスト機能を用いることによって、複数の I/O デバイスに同一のデータを配布するように構成することができ、またネットワーク、インタフェースは上記した FDDI、SCSI に限定されず、他のネットワーク、インタフェースであってもよい。

[0044]

【発明の効果】

以上、説明したように、請求項 1 記載の発明によれば、ネットワーク制御手段と I/O デバイス制御手段とプロトコル変換手段からなるマルチアクセス制御手段を設けているので、I/O デバイスを変更することなく、複数の情報処理装置から複数の I/O デバイスへのアクセスが可能になる。

[0045]

請求項 2 記載の発明によれば、I/O デバイス制御部と I/O デバイス内の SCSI コントローラとを共用化しているので、装置構成を簡単化できる。

[0046]

請求項 3 記載の発明によれば、複数の情報処理装置が実行した処理データを I/O デバイスに格納しているので、障害発生時に高速に予備切替を行うことができる。

dedicated, as for SCSI controller 512 it is a reception dedicated.

And, it starts reading writing to I/O device 70 from I/O device 70 making use of SCSI controller 511, SCSI controller 512 uses.

However, command for I/O device does with all SCSI controller 511 regardless of transmit receive.

[0042]

system of this working example, when I/O device 1 is, especially effective.

In other words, because specific is possible device to 1, only the initial one time does arbitration, selection, after that it is possible at time of the access to abbreviate arbitration, selection:

Therefore, after [komandokonpuriito] transmitting, without BASF Lee doing with the phase transition of SCSI, because again it can make command phase, high speed data access becomes possible.

[0043]

Furthermore, this working example can do in order by fact that for other than those which were inscribed, broad cast function is used, distribution fabric to do same data to I/O device of plural, configuration, in addition network, interface is not limited in FDDI, SCSI which was inscribed, is good even with other network, interface.

[0044]

[Effects of the Invention]

As above, explained, according to invention which is stated in the Claim 1, because multi access control means which consists of network control means and I/O device control means and protocol conversion means is provided, from information processing apparatus of plural access to the I/O device of plural becomes possible without modifying I/O device.

[0045]

According to invention which is stated in Claim 2, because the SCSI controller inside I/O device control unit and I/O device is converted commonly, equipment configuration can be simplified.

[0046]

According to invention which is stated in Claim 3, because the treatment data which information processing apparatus of plural executed is housed in the I/O device, it is possible at time of damage to do preparatory changeover in the high

【0047】

請求項 4 記載の発明によれば、バックアップデータを一元管理することができ、特に DAT の如き着脱可能な I/O デバイスを用いた場合、I/O デバイス毎にバックアップする情報処理装置を特定することにより、メディア管理が容易になる。

【0048】

請求項 5 記載の発明によれば、SCSI を送信インタフェースと受信インタフェースに分離しているため、高スループットの I/O デバイスアクセスを実現することができる。

【図面の簡単な説明】

【図1】

本発明の一実施例に係るシステム構成図である。

【図2】

マルチアクセス制御装置のブロック構成図である。

【図3】

情報処理装置からマルチアクセス制御装置への制御フレームのフォーマットを示す図である。

【図4】

マルチアクセス制御装置から情報処理装置への終了フレームのフォーマットを示す図である。

【図5】

情報処理装置からマルチアクセス制御装置へのアクセスシーケンスを示す。

【図6】

マルチアクセス制御装置と I/O デバイスを一体化させた場合の他の実施例の構成である。

【図7】

現用系情報処理装置から予備系情報処理装置への切替えを行う場合の他の実施例の構成を示す図である。

【図8】

情報処理装置を I/O デバイスによってバックアップする場合の他の実施例の構成を示す図である。

speed .

【0047】

According to invention which is stated in Claim 4, it is possible to manage backup data monistically, when demountable I/O device like the specially DAT is used, media management becomes easy by specific doing information processing apparatus which backup is done in every I/O device .

【0048】

According to invention which is stated in Claim 5, because the SCSI is separated into transmission interface and reception interface , I/O device access of high throughput can be actualized.

[Brief Explanation of the Drawing(s)]

【Figure 1】

It is a system diagram which relates to one Working Example of this invention .

【Figure 2】

It is a block diagram of multi access control device .

【Figure 3】

It is a figure which shows format of control frame to multi access control device from information processing apparatus .

【Figure 4】

It is a figure which shows format of end frame to information processing apparatus from multi access control device .

【Figure 5】

access sequence to multi access control device is shown from information processing apparatus .

【Figure 6】

It is a configuration of other Working Example when multi access control device and I/O device are unified.

【Figure 7】

It is a figure which shows configuration of other Working Example when changeover to preparatory information processing apparatus is done from current system information processing apparatus .

【Figure 8】

information processing apparatus it is a figure which shows configuration of other Working Example when backup it does with I/O device .

【図9】

マルチアクセス制御装置が2本のSCSIを制御する他の実施例の構成を示す図である。

【符号の説明】

10
FDDI
20
情報処理装置
30
情報処理装置
40
情報処理装置
50
マルチアクセス制御装置
500
ネットワーク制御部
510
I/Oデバイス制御部
520
プロトコル変換部
60
SCSI
70
I/Oデバイス
80
I/Oデバイス
90
I/Oデバイス

Drawings

【図1】

[Figure 9]

It is a figure which shows configuration of other Working Example where the multi access control device controls SCSI of 2.

[Explanation of Symbols in Drawings]

10
FDDI
20
information processing apparatus
30
information processing apparatus
40
information processing apparatus
50
multi access control device
500
network control unit
510
I/O device control unit
520
protocol conversion section
60
SCSI
70
I/O device
80
I/O device
90
I/O device

[Figure 1]

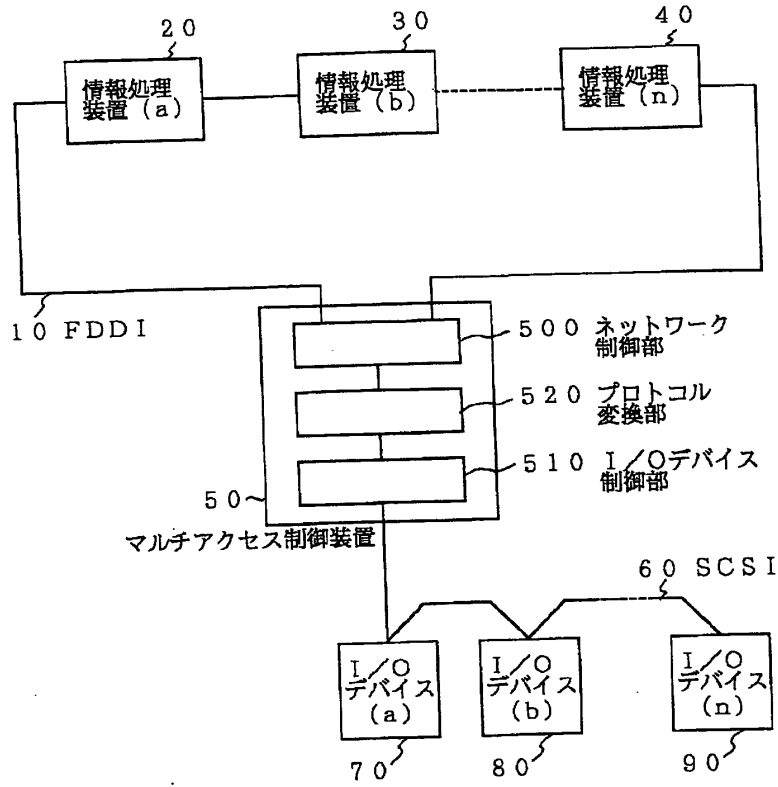

【図9】

[Figure 9]

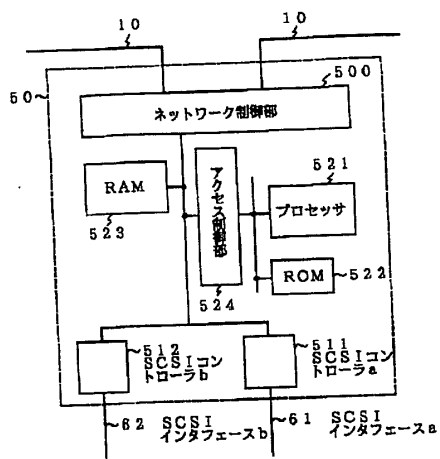

【図2】

[Figure 2]

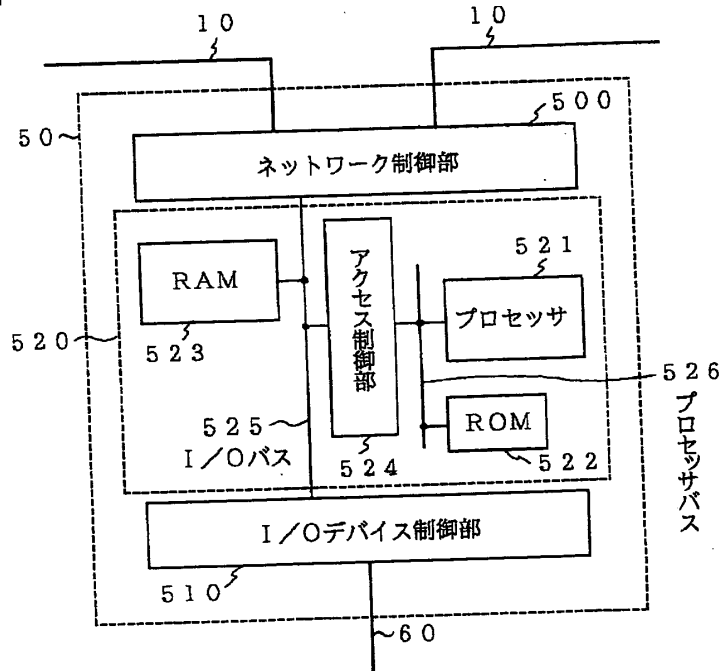

【図3】

[Figure 3]

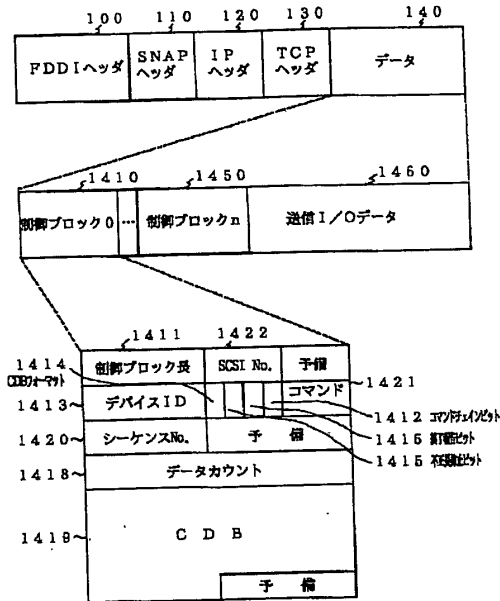

【図4】

[Figure 4]

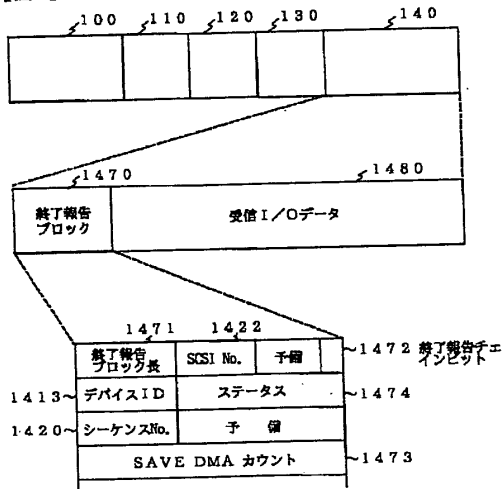

【図5】

[Figure 5]

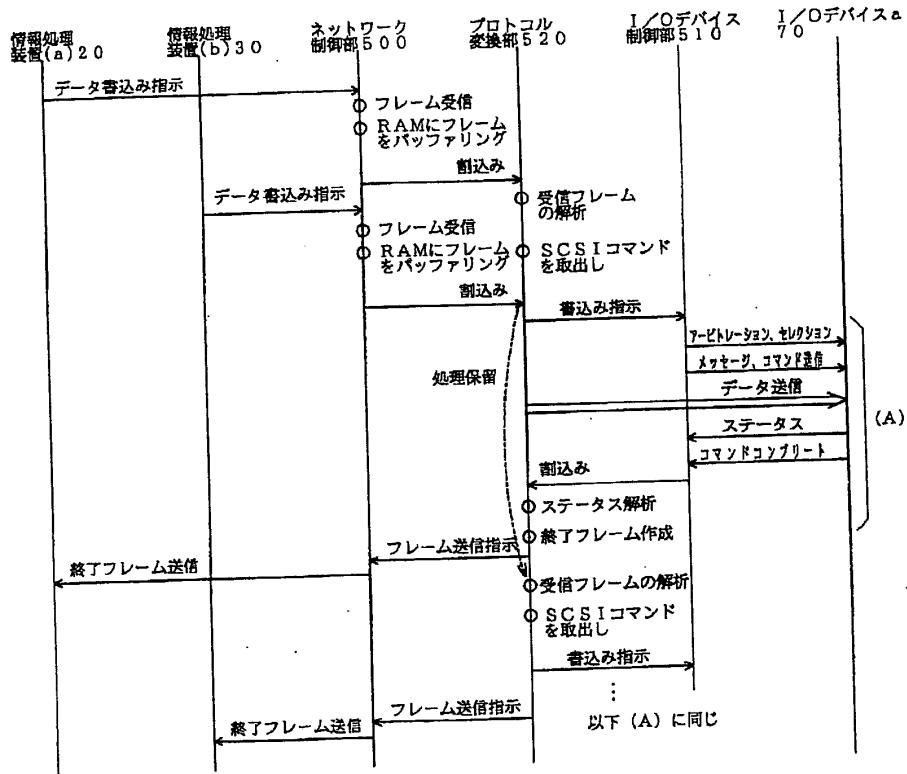

【図6】

[Figure 6]

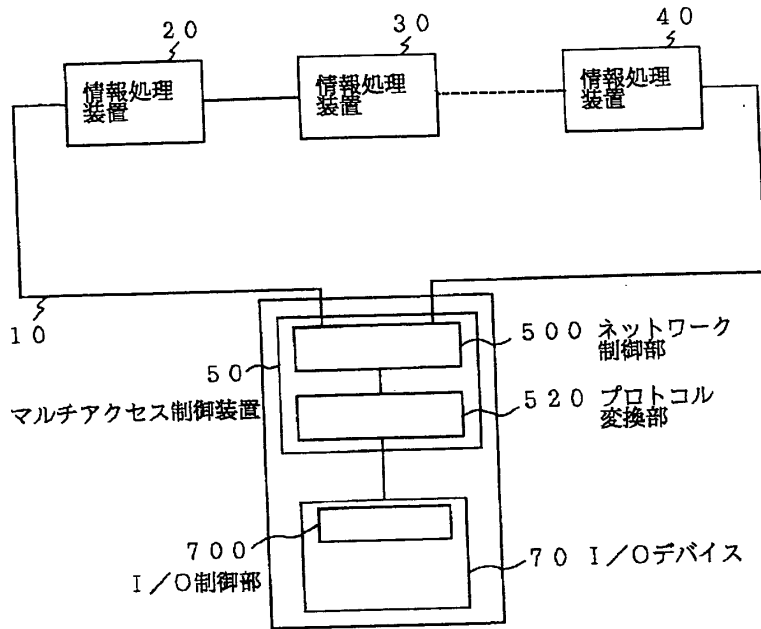

【図8】

[Figure 8]

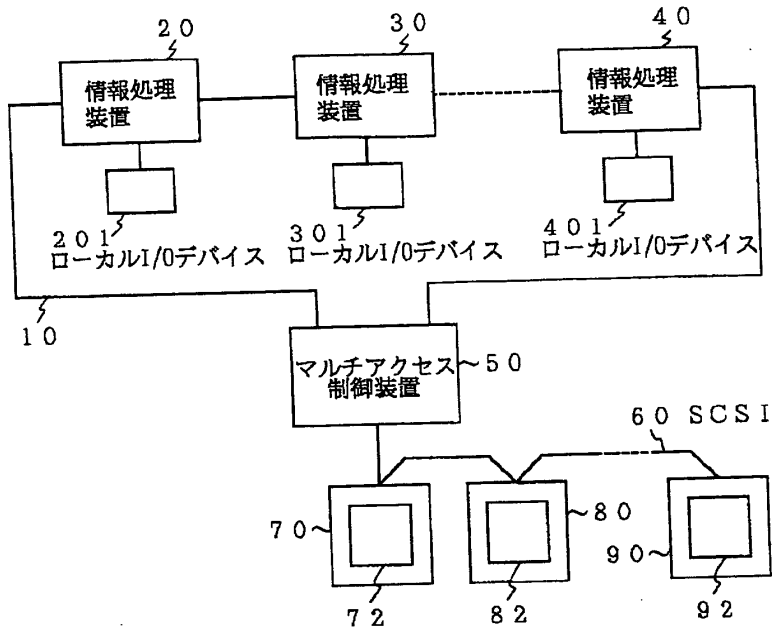

【図7】

[Figure 7]

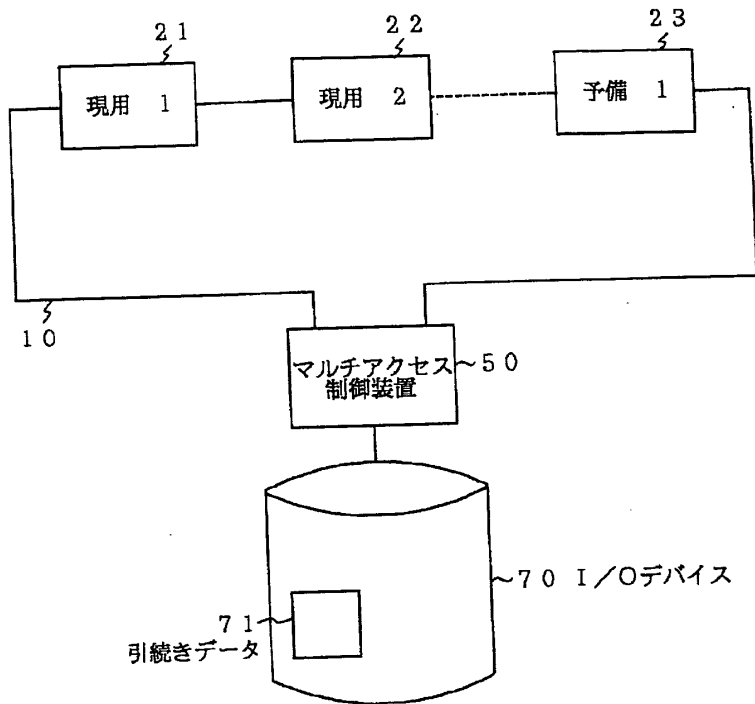

**This Page is Inserted by IFW Indexing and Scanning
Operations and is not part of the Official Record**

BEST AVAILABLE IMAGES

Defective images within this document are accurate representations of the original documents submitted by the applicant.

Defects in the images include but are not limited to the items checked:

- BLACK BORDERS
- IMAGE CUT OFF AT TOP, BOTTOM OR SIDES
- FADED TEXT OR DRAWING
- BLURRED OR ILLEGIBLE TEXT OR DRAWING
- SKEWED/SLANTED IMAGES
- COLOR OR BLACK AND WHITE PHOTOGRAPHS
- GRAY SCALE DOCUMENTS
- LINES OR MARKS ON ORIGINAL DOCUMENT
- REFERENCE(S) OR EXHIBIT(S) SUBMITTED ARE POOR QUALITY
- OTHER: _____

IMAGES ARE BEST AVAILABLE COPY.

As rescanning these documents will not correct the image problems checked, please do not report these problems to the IFW Image Problem Mailbox.



B3

INTERNATIONAL APPLICATION PUBLISHED UNDER THE PATENT COOPERATION TREATY (PCT)

<p>(51) International Patent Classification ⁶ : G06F 12/00</p>	<p>A1</p>	<p>(11) International Publication Number: WO 98/36357 (43) International Publication Date: 20 August 1998 (20.08.98)</p>
<p>(21) International Application Number: PCT/US98/02131 (22) International Filing Date: 5 February 1998 (05.02.98) (30) Priority Data: 08/796,085 5 February 1997 (05.02.97) US (71) Applicant: TRANSWITCH CORPORATION [US/US]; 3 Enterprise Drive, Shelton, CT 06484 (US). (72) Inventors: LAU, Joseph, C.; 1F, 29 Bamboo Road III, Science-based Industry Park, Hsinchu (TW). ROY, Subhash, C.; Apartment 3A, 905 Mix Avenue, Hamden, CT 06514 (US). CALLAERTS, Dirk, L., M.; Hoevestraat 13, B-3110 Rotselaar (BE). VANDEWEERD, Ivo, Edmond, Nicole; Vuurkruisenlaan 1, B-3500 Hasselt (BE). (74) Agent: GORDON, David, P.; 65 Woods End Road, Stamford, CT 06905 (US).</p>	<p>(81) Designated States: CA, CN, IL, JP, MX, NO, European patent (AT, BE, CH, DE, DK, ES, FI, FR, GB, GR, IE, IT, LU, MC, NL, PT, SE). Published <i>With international search report. Before the expiration of the time limit for amending the claims and to be republished in the event of the receipt of amendments.</i></p>	

PCT: AVAILABLE UNTIL

(54) Title: SHARED MEMORY CONTROL USING MULTIPLE LINKED LISTS WITH POINTERS, STATUS FLAGS, MEMORY BLOCK COUNTERS AND PARITY

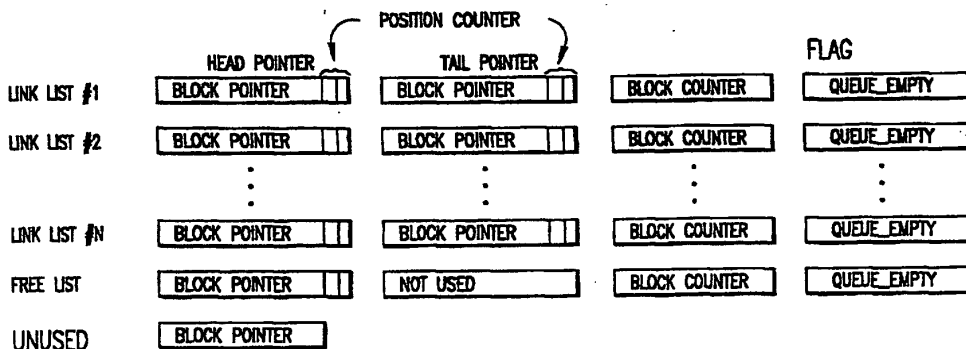

(57) Abstract

Apparatus and methods for allocating shared memory utilizing linked lists (LLs) use a management RAM which controls the flow of data to/from a shared memory (RAM), and stores information regarding a number of LLs and a free link list (FLL) in the RAM, and a block pointer to unused RAM locations. A head pointer (HP), tail pointer (TP), block counter and empty flag (EF) are stored for each data link list. The HP and TP each include a block pointer and a position counter. The block counter contains the number of blocks used in the particular queue. An EF indicates an empty queue. The FLL includes a HP, a block counter, and an EF. Each page of RAM receiving the incoming data includes locations for storing data. The last location of the last page in a block stores a next-block pointer plus parity information, and in the last block of a queue, is set to all ones. An independent agent used in the background monitors the integrity of the LL structure.

FOR THE PURPOSES OF INFORMATION ONLY

Codes used to identify States party to the PCT on the front pages of pamphlets publishing international applications under the PCT.

AL	Albania	ES	Spain	LS	Lesotho	SI	Slovenia
AM	Armenia	FI	Finland	LT	Lithuania	SK	Slovakia
AT	Austria	FR	France	LU	Luxembourg	SN	Senegal
AU	Australia	GA	Gabon	LV	Latvia	SZ	Swaziland
AZ	Azerbaijan	GB	United Kingdom	MC	Monaco	TD	Chad
BA	Bosnia and Herzegovina	GE	Georgia	MD	Republic of Moldova	TG	Togo
BB	Barbados	GH	Ghana	MG	Madagascar	TJ	Tajikistan
BE	Belgium	GN	Guinea	MK	The former Yugoslav Republic of Macedonia	TM	Turkmenistan
BF	Burkina Faso	GR	Greece	ML	Mali	TR	Turkey
BG	Bulgaria	HU	Hungary	MN	Mongolia	TT	Trinidad and Tobago
BJ	Benin	IE	Ireland	MR	Mauritania	UA	Ukraine
BR	Brazil	IL	Israel	MW	Malawi	UG	Uganda
BY	Belarus	IS	Iceland	MX	Mexico	US	United States of America
CA	Canada	IT	Italy	NE	Niger	UZ	Uzbekistan
CF	Central African Republic	JP	Japan	NL	Netherlands	VN	Viet Nam
CG	Congo	KE	Kenya	NO	Norway	YU	Yugoslavia
CH	Switzerland	KG	Kyrgyzstan	NZ	New Zealand	ZW	Zimbabwe
CI	Côte d'Ivoire	KP	Democratic People's Republic of Korea	PL	Poland		
CM	Cameroon	KR	Republic of Korea	PT	Portugal		
CN	China	KZ	Kazakstan	RO	Romania		
CU	Cuba	LC	Saint Lucia	RU	Russian Federation		
CZ	Czech Republic	LI	Liechtenstein	SD	Sudan		
DE	Germany	LK	Sri Lanka	SE	Sweden		
DK	Denmark	LR	Liberia	SG	Singapore		
EE	Estonia						

SHARED MEMORY CONTROL USING MULTIPLE LINKED LISTS WITH POINTERS, STATUS FLAGS, MEMORY BLOCK COUNTERS AND PARITY

This application is related to co-owned U.S. Serial No. 08/650,910, filed May 17, 1996, which is hereby incorporated by reference herein in its entirety.

BACKGROUND OF THE INVENTION

1. Field of the Invention

The present invention relates to memory management. More particularly, the present invention relates to apparatus and methods of managing a plurality of data queues stored in linked lists in a shared common memory. The invention has particular application to the use of a very large scale integrated circuit (VLSI) for the buffering of telecommunications information such as ATM data, although it is not limited thereto.

2. State of the Art

In high speed communication networks, the management of buffer resources is one mechanism of increasing network performance. One group of methods of managing buffer resources is known as sharing, where a single RAM is simultaneously utilized as a buffer by a plurality of different channels. Various sharing methods are known (see Velamuri, R. et al., "A Multi-Queue Flexible Buffer Manager Architecture", IEEE Document No. 0-7803-0917-0/93) and each has inherent advantages coupled with inherent disadvantages in terms of blocking probability, utilization, throughput, and delay. What is common to all sharing methods, however, is that a mechanism is required to direct data into appropriate locations in the RAM in a desired order so that the data can be retrieved from the RAM appropriately. One such mechanism which is well known is the use of link lists which are used to manage multiple queues sharing a common memory buffer. Typically, a link list comprises bytes of data, where each byte has at least one pointer (forward and/or backward) attached to it, thereby identifying the location of the next byte of data in the queue. The link list typically includes extensive

initialization and self-check procedures which are carried out by a microprocessor on a non-real-time basis. Thus, the use of standard prior art link list structures to manage multiplex queues sharing a common memory is not readily adaptable for VLSI implementation, and is likewise not particularly suited to the handling of very high speed telecommunications information where processing and handling are dictated by the data rate of the real-time telecommunications signal.

SUMMARY OF THE INVENTION

It is therefore an object of the present invention to provide an apparatus and method for control of memory allocation.

It is another object of the invention to provide a new link list structure for managing queues in a shared memory.

It is a further object of the invention to provide a single VLSI which utilizes a link list structure for managing queues of high speed real time data in a shared memory.

It is an additional object of the invention to provide a link list apparatus and method for controlling the flow of Asynchronous Transfer Mode (ATM) telecommunications data into and out of a shared buffer.

Another object of the invention is to provide an apparatus and method for VLSI control of ATM data into and out of a shared RAM by utilizing a separate RAM containing information related to the plurality of link lists in the shared RAM.

In accord with the objects of the invention a management RAM contained within a VLSI is provided for controlling the flow of data into and out of a shared memory (data RAM). The management RAM is preferably structured as an x by y bit RAM which stores information regarding y-2 data link lists in the shared RAM, a free link list in the shared RAM, and a block pointer to unused shared RAM locations. Information stored in the x bits for each

data link list includes a head pointer, a tail pointer, a block counter and an empty flag. In a preferred embodiment particularly applicable to the control of ATM data, the head and tail pointers are each composed of a block pointer and a position counter, with the position counter indicating a specific page in a block which is made up of a set of contiguous pages of memory, and the block pointer pointing to the block number. Regardless of how constituted, the head pointer contains the address of the first word of the first memory page of the link list, and the tail pointer preferably contains the address of the first word of the last memory page in the link list. The block counter contains the number of blocks used in the particular queue, and has a non-zero value if at least one page is used in the queue. The empty flag indicates whether the queue is empty such that the content of the link list should be ignored if the queue-empty flag indicates that the queue is empty.

Information stored in the management RAM for the free link list includes a head pointer, a block counter, and an empty flag, but does not need to include a tail pointer as free blocks are added to the top of the free list according to the preferred embodiment of the invention. As is discussed below in more detail, as data from different channels is directed into blocks of the data RAM, a link list is kept for each channel. As data is read out of the data RAM, blocks become available to receive new data. It is these freed blocks which are added to the free list. Block space can be assigned from the free list before or after the unused blocks (discussed below) are used.

To avoid excessive initialization requirements, an unused-block pointer is provided in the management RAM, as discussed above, and provides a pointer to the next unused block in memory. Initially all link lists, including the free list, are empty, and the unused block pointer is set to the number of blocks in the memory. As data is written to a block of shared RAM memory, the unused block pointer is decremented. When the unused block pointer equals zero, all of the cell blocks are included in the link lists (including the free link list).

According to a preferred aspect of the invention, each memory page of the shared data RAM receiving the incoming data (which RAM is managed by the management RAM) is composed of M contiguous memory addresses. Depending on the memory type, each address location can be of size B bits. The most common sizes are eight bits (byte), sixteen bits (word), thirty-two bits, and sixty-four bits. The first M-1 locations in the page are used to store data. The last (M'th) location of the last page in the block preferably is used to store the address of the first location of the next block of the queue plus an odd parity bit; i.e., the M'th location of the last page in the block stores a next block pointer plus parity information. If there are no more blocks in the queue, the M'th location in the last page is set to all ones.

According to another aspect of the invention, an independent agent is utilized in the background to monitor the integrity of the link list structure. The independent agent monitors the sum of the count of all of the link list block counters plus the unused blocks to ensure that it equals the total number of memory blocks in the common RAM. If not, an error is declared. Likewise, the independent agent checks each link list stored in the management RAM for the following error conditions: head and tail pointers are equal and the block counter is not of value one; head and tail pointers are different and the block counter is one; and, block counter equals zero. If desired, the independent agent can also monitor the block pointers stored in the M'th location of the last page of each block to determine parity errors and/or to determine errors using parity or CRC.

Using the methods and apparatus of the invention, four operations are defined for ATM cell management: cell write, cell read, queue clear, and link list monitoring. In the cell write operation, a cell is stored into a queue. More particularly, when an ATM cell is received at a port w so that it is to be stored in queue number n (which stores cells of priority v for port w), a determination is first made as to whether the queue is empty. If it is not empty, the queue status (i.e., the tail

pointer and position counter stored in management RAM) is obtained, and a determination is made as to whether a new block will be needed to be added to the queue. If a new block is not required, the cell is written to the location indicated by the tail pointer position, and the tail pointer position counter for that queue in the management RAM is updated. If this is the last page of a block, the M'th location of the page (in the shared memory) is set to all ones. If a new block is required, either because the queue was empty or because a previous cell had been written into the last page of a block, a block must be obtained. If it is a first block of a queue, initial queue parameters are stored. If it is not the first block of the link list, a block is obtained from the free list and the free list is updated; or the block is obtained from the unused blocks and the block pointer for the unused blocks is updated. Then, the cell is written to the queue, and the tail pointer, position counter, and block counter for the queue are all updated in the management RAM.

The cell read operation is utilized where a cell is to be read from a queue. In the cell read operation, the cell indicated by the head pointer and head pointer position counter for that queue is read from the queue. After reading the cell from the queue a determination is made as to whether the cell was either the last cell in a block and/or the last cell in the queue. If it is neither, then the queue status is updated (i.e., the head pointer position counter is changed), and another cell read operation is awaited. If the cell is the last cell in the block, then the queue status preferably is checked for correctness by verifying the parity of the pointer (using a parity bit), and is updated by changing the head pointer and head pointer position counter. The free list is updated by adding the freed block to the head of the free list, and the free list and link list block counters are updated. If the cell is the last cell in the queue, the procedure for the last cell in the block is followed, and the queue empty flag is set.

The queue clear operation is a microprocessor command provided for the purpose of clearing a queue. When the queue clear operation is presented, the queue status is updated by setting the queue flag, and the blocks in the queue are added to the head of the free list which is likewise updated.

The link list monitoring operation is the agent which monitors the integrity of the link list structure whenever the cell write, cell read, and queue clear operations are not running. As set forth above, the link list monitoring operation monitors the linked lists for errors by checking that the sum of the count of all of the link list block counters plus the unused blocks equals the total number of memory blocks in the common RAM, that when head and tail pointers are equal the block counter is set to one, that when head and tail pointers are different the block counter is not set to one, etc.

Additional objects and advantages of the invention will become apparent to those skilled in the art upon reference to the detailed description taken in conjunction with the provided figures.

BRIEF DESCRIPTION OF THE DRAWINGS

Figure 1 is a block diagram of an apparatus incorporating the link list memory management RAM of the invention.

Figure 2 is a chart showing the structure of the memory management RAM of Figure 1.

Figure 3a is a diagram of an example of the shared data memory of the apparatus of Figure 1.

Figure 3b is a diagram of the details of a page of one of the blocks shown in Figure 3a.

Figure 3c is a diagram of an example of the information contained in the memory management RAM of Fig. 1 for managing the shared data memory example of Figure 3a.

Figures 4a - 4d are flow charts for the write, read, queue clear, and link list monitoring operations carried out by the flow controller of the apparatus of Figure 1.

Figures 5a-5d are state machine diagrams for a write, read, clear, and monitor state machine according to the invention.

DETAILED DESCRIPTION OF THE PREFERRED EMBODIMENTS

The invention will now be described with reference to the physical layer VLSI portion of an ATM destination switch described in parent U.S. Serial No. 08/650,910, although it is not limited thereto. As seen in Fig. 1, and as discussed in the parent application, the physical layer portion 130 of the ATM destination switch 100 preferably includes a UTOPIA interface 150, a managing RAM 162, a flow controller 166, a microprocessor interface 167, channel interface buffers 170, and a RAM interface 175. The flow controller 166 is coupled to the UTOPIA interface 150, the managing RAM 162, the microprocessor interface 167, the channel interface buffers 170, and the RAM interface 175. The UTOPIA interface generally receives cells of ATM data in a byte-wide format, and passes them to the flow controller 166. Based on the destination of the cell (as discussed in the parent application), and the priority of the cell, the flow controller 166 writes the cell into an appropriate output buffer 170. The output buffer is preferably capable of storing at least two ATM cells so that one cell can be read out of the buffer as another is being read into the buffer without conflict. If buffer space is not available for a particular cell at a particular time, the flow controller 166 forwards the ATM cell via the RAM interface 175 to a desired location in a shared RAM 180 (which may be on or off chip) based on information contained in the managing RAM 162 as discussed in more detail below. When room becomes available in the output buffer 170 for the cell, the flow controller 166 reads the data out of the shared RAM 180, and places it in the buffer 170. In the background, when not receiving data from the UTOPIA interface, and when not reading data from or writing data to the shared RAM 180 or writing data to the buffers, the flow

controller 166 monitors the integrity of the link list structure contained in the managing RAM, as is described in more detail below. In addition, the flow controller 166 can perform various functions in response to microprocessor command received via the microprocessor interface 167.

The managing RAM 162 may serve various functions, including providing information for assisting in the processing of the header of the ATM cell as discussed in the parent application hereto. For purposes of this invention, however, the managing RAM 162, or at least a portion thereof, is preferably provided as a x bit by y word RAM for the purpose of managing $y-2$ link lists which are set up in the shared RAM 180 ($y-2$ equalling the product of w ports times v priorities). Thus, as seen in Fig. 2, a link list information structure for $y-2$ data queues includes: a head pointer, a tail pointer, a block counter, and a queue empty flag for each of the $y-2$ data queues; a free list block pointer, block counter, and queue empty flag for a free list; and a block pointer for the unused blocks of memory. Each head pointer and tail pointer preferably includes a block pointer and a position counter, with the block pointer used for pointing to a block in the memory, and the position counter being used to track pages within a block of memory. Thus, for example, where ATM cells of fifty-three bytes of data are to be stored in the shared memory, and each cell is to be stored on a "page", a block having four contiguous pages may be arranged with the position counter being a two bit counter for referencing the page of a block. The block counter for each queue is used to reference the number of blocks contained within the queue. The queue empty flag when set indicates that the queue is empty, and that the pointers contained within the queue as well as the block count can be ignored.

As suggested above, the head pointer for each link list queue contains the address of the first word of the first memory page of the queue in the shared memory. The tail pointer for each link list queue contains the address of the first word of the last memory page in the queue. Each memory page of the shared

memory is composed of M contiguous memory addresses. Depending on the memory type, each address location can be of size B bits, with common sizes being eight bits (byte), sixteen bits (word), thirty-two bits, or sixty-four bits. In accord with the preferred embodiment of the invention, the address locations are sixteen bits in length with the first M-1 locations in a page containing the stored information. The M'th location of a last page in a block is used to store a next block pointer which is set to the first location of the next block plus an odd parity bit. Where the block is the last block in the queue, the M'th location of the last page in the last block is set to all ones. Where the page is neither the last page of the block, nor the last block in the queue, the M'th location of the page is not utilized. In the preferred embodiment of the invention used with respect to ATM telecommunications data, each page is thirty-two words in length (i.e., M = 32), with each word being sixteen bits. Thus, an ATM cell of fifty-three bytes can be stored on a single page with room to spare. It should be appreciated, that in some applications, only the data payload portion of the ATM cell (i.e., forty-eight bytes), and not the overhead portion (five bytes) will be stored in the shared memory. In other applications, such as in switches where routing information is added, cells of more than fifty-three bytes may be stored. Regardless, with a thirty-two word page, system addressing is simplified.

An example of the memory organization of the shared memory is seen in Fig. 3a. In Fig. 3a, two active link list data queues are represented, as well as a free list queue and an Unused block. In particular, memory blocks 512, 124, and 122 are shown linked together for a first queue, memory blocks 511, 125, and 123 are linked together for a second queue, memory blocks 510 - 125 are linked together for the free list queue, and memory blocks 121 - 1 are Unused. It will be appreciated that in the preferred embodiment of the invention, each page contains thirty-two sixteen bit words. Thus, the thirty-second (M'th) word of memory block 512 (seen in more detail in Fig. 3b) contains a pointer (the ten least significant bits) which points to memory block 124, the thirty-second word of memory block 124 contains a

pointer which points to memory block 122, and the thirty-second word of memory block 122 contains all ones, thereby indicating the last word in the queue. Likewise, the thirty-second word of memory block 511 contains a pointer which points to memory block 125, the thirty-second word of memory block 125 contains a pointer which points to memory block 123, and the thirty-second word of memory block 123 contains all ones, thereby indicating the last word of that queue.

The free list of Fig. 3a is seen extending from block 510 to block 126. The unused blocks run from block 121 to block 1.

Turning to Fig. 3c, specifics are seen of the management RAM which would be associated with managing the shared memory in the state of Fig. 3a. In particular, information for link list #1 is seen with a head pointer having a block pointer having a value equal to 512 and a position counter set at "00" to indicate a first page of memory in the block storing data. The tail pointer of the link list #1 information has a block pointer having a value equal to 122 and a position counter set to "11" to indicate that all pages of block 122 are being used. The block counter of the information for link list #1 is set to a value of three, and the queue empty flag is not set (i.e., equals zero). Information for link list #2 is seen with a head pointer having a block pointer having a value equal to 511 and a position counter set at "01" to indicate that the data first occurs at a second page of the block (i.e., the first page already having been read from the block). The tail pointer of the link list #2 information has a block pointer having a value equal to 123 and a position counter set at "10" which indicates that there is no data in the last page of the block. The block counter of the link list #2 information is also set to a value of three, and the queue empty flag is not set. The value of the head and tail pointers and block count for the information of link list #N are not indicated, as the queue empty flag of link list #N is set (equals one), thereby indicating that the pointers and block counter do not store valid data. Likewise, while details of information for other link lists are not shown, the only data of interest would

be that the queue empty flags related to all of those link lists would equal one to indicate that no valid data is being stored with reference to those link lists. The head pointer of the free list information has a block pointer set to a value 510, and a block count of 385. The queue empty flag of the free list is not set, as the free list contains data. Finally, the block pointer relating to the Unused queue is shown set to a value of 121. It is noted that in order to increase performance, the free list head pointer and block counter information is preferably implemented in a series of flip-flops, and is thus readily available for purposes discussed below with reference to Figs. 4a-4d. The queue empty flags are also preferably similarly implemented.

It should be appreciated that by providing the queue empty flags and an Unused block pointer, excessive initialization requirements are eliminated. As suggested above, the queue empty flag indicates that there is no valid data for a link list and that the head and tail pointers for that link list and the block counter of that link list can be ignored. The Unused block pointer is provided to point to the next unused block in shared memory. As memory pages are written or used, the Unused block pointer is decremented until a value of zero is reached. At that point, all cell blocks are included in the link lists (including the free list). As previously mentioned, when a block is read from the shared memory, the available block is added to the free list. When a new block is required for adding to a link list, the block space may be taken from either the free list or from the Unused blocks, and available blocks from the free list may be taken either before or after the Unused blocks are used.

Turning now to Figure 4a, a flow chart of operations of the flow controller 166 of the apparatus 100 of Figure 1 is seen with respect to writing data to the shared memory. It is noted that while the operations are shown in flow chart form, in accord with the preferred embodiment of the invention, the operations are carried out in hardware. When the flow controller 166 determines that it is receiving an ATM cell which cannot be written into a

buffer directly, the flow controller makes a determination at 200 (by checking the management RAM queue empty flag associated with that queue) as to whether the queue which should receive that cell is empty. If the queue is not empty, at 202 the queue status (i.e., the tail pointer and position counter) for that queue is obtained, and at 204 a determination is made as to whether a new block will be needed to be added to the queue (i.e., is the position counter equal to "11"). If a new block is not required, at 206 the cell is written to the shared RAM location indicated by the tail pointer position counter for that queue (stored in management RAM), and at 208 the tail pointer position counter for that queue is updated. At 210, a determination is made as to whether the cell is being written into the last page of a block. If so, at 212 the flow controller writes a word of all ones into the M'th location of the page (in the shared memory).

If it is determined that a new block of shared RAM is required to store the incoming cell because at 200 the queue was empty, at 214, a block is obtained from either the free list or from unused RAM. If the block is obtained from the free list, at 216, the free list information is updated by changing the head pointer of the free list (i.e., setting the head pointer to the value stored in the M'th location of the last page of the obtained block), and by decrementing the block counter associated with the free list. If the block is obtained from the unused RAM, the block pointer for the unused RAM is decremented at 216. Regardless, at 218, the cell is written to the queue, and at 220, the tail pointer and block counter for the queue are both updated in the management RAM (with the block counter being set to the value one), and the queue empty flag is changed.

If it is determined that a new block of shared RAM is required to store the incoming cell because at 204 the tail pointer position counter of the link list indicated that the entire tail block is storing data, at 222, a block is obtained from either the free list or from unused RAM. If the block is obtained from the free list, at 224, the free list is updated by

changing the head pointer of the free list (i.e., setting the head pointer to the value stored in the M'th location of the last page of the obtained block), and by decrementing the block counter associated with the free list. If the free list becomes empty because a block is removed, the queue empty flag of the free list is set. If the block is obtained from the unused RAM, the block pointer for the unused RAM is decremented at 224. Regardless, at 228, the cell is written to the queue, and at 230, the tail pointer and block counter for the queue are both updated in the management RAM.

The details of the flow controller operation with respect to a cell read operation (i.e., where a cell is to be read from a queue because a buffer is available to receive the cell) is seen in Fig. 4b. In particular, when a data buffer becomes available, the flow controller at 250 reads the head pointer and tail pointer in the management RAM for the link list associated with the available data buffer. Then, at 252, the flow controller reads from shared memory the cell at the location in the shared memory indicated by the head pointer, and provides the cell to the data buffer. After the data has been read, the flow controller determines at 254 (based on the head pointer and tail pointer) whether the cell was the last cell in the queue, and at 256 (based on the head pointer position counter) whether the cell was the last cell in a block. If it is neither, then at 258 the queue status is updated (i.e., the head pointer position counter is changed), and another cell read operation is awaited. If at 254 it is determined that the cell is the last cell in the queue, at 260, the head pointer for the free list (obtained from the management RAM) is inserted into the last word of the last page of the freed block. Then at 262, the free list in the management RAM is updated by adding the freed block to the head of the free list; i.e., by updating the free list block pointer and block counter. At 264, the queue empty flag is set for the link list which now has no blocks. If the free list was empty prior to adding the freed block, the free list must be initialized (with appropriate head pointer and block counter) and the queue empty flag changed at 264. In addition, in the case were the free list

was empty prior to adding the freed block, the last word in the freed block in the shared RAM should be set to all ones.

If at 256 it is determined that the cell which has been read out of shared memory is the last in a block, then at 266, the head pointer for the free list as obtained from the management RAM is inserted into the last word of the last page of the freed block. Then, at 268, the queue status for the link list is updated by changing the block pointer and position counter of the head pointer (to the value contained in the last word of the page of memory being read out of the shared memory), and by decrementing the block counter. Again, it is noted that if the free list was empty prior to adding the freed block, the free list must be initialized (with appropriate head pointer and block counter) and the queue empty flag changed, and the last word in the freed block in the shared RAM should be set to all ones. It is also noted, that upon obtaining the pointer in the M'th location of the last page of the block, according to the preferred embodiment of the invention, at 270, a parity check is done on the pointer. At 272, the calculated parity value is compared to the parity bit stored along with the pointer. Based on the comparison, at 274, a parity error condition can be declared, and sent as an interrupt message via the microprocessor interface port 167 (Fig. 1) to the microprocessor (not shown). Preferably, when a parity error is found, the microprocessor treats the situation as a catastrophic error and reinitializes the management and data RAMs.

Figure 4c sets out the operation with respect to the queue clear microprocessor command (received via the microprocessor interface 167). When the queue clear operation is presented, at 270 the queue status for the link list is updated by setting the queue empty flag, and at 272, the blocks in the queue are added to the head of the free list which is updated in a manner discussed above (Fig. 4b) with reference to the cell read operation.

The link list monitoring operation seen in Fig. 4d is the hardware agent which monitors the integrity of the link list structure whenever the cell write, cell read, and queue clear operations are not running. The link list monitoring operation preferably monitors four different error conditions. In particular, at 280, the counts of all of the link list block counters (including the free list) where the queue empty flag for those link lists are not set are summed together with the unused blocks and compared the total number of memory blocks in the common RAM. If the sum does not equal the total number of memory blocks in the common RAM, at 281, an error condition is declared by triggering a microprocessor interrupt bit. At 282, the head and tail block pointers of each link list are compared. If at 284 the head and tail block pointers are determined to be equal, at 286 the block counter is checked, and if not equal to one, at 287 an error condition is declared. If the head and tail block pointers are not equal when compared at 284, at 288 the block counter is checked, and if the block count is equal to one, at 289 an error condition is declared. At 290, the block counter for each link list whose queue empty flag is not set is checked; and if the block counter equals zero, at 291 an error condition is declared.

According to the preferred embodiment of the invention, the write, read, clear, and monitoring operations of the flow controller are carried out in hardware which may be generated by using HDL code to synthesize hardware gates via use a VHDL compiler. Figures 5a-5d are state machines diagrams corresponding to the HDL code, including a write state machine (Fig. 5a), a read state machine (Fig. 5b), a clear state machine (Fig. 5c), and a monitoring state machine (Fig. 5d). The gates created using the code may be standard cell technology or gate array technology.

It should be appreciated that the invention is not intended to be limited to a strictly hardware implementation, but is also intended to apply to memory management utilizing a microprocessor with associated firmware (e.g., a ROM).

There have been described and illustrated herein an apparatus and method for management of shared memory. While particular embodiments of the invention have been described, it is not intended that the invention be limited thereto, as it is intended that the invention be as broad in scope as the art will allow and that the specification be read likewise. Thus, while the invention has been described with reference to VLSI implemented ATM equipment, it will be appreciated that the invention has broader applicability. Also, while specific details of RAM sizes, etc. have been disclosed, it will be appreciated that the details could be varied without deviating from the scope of the invention. For example, while a management of RAM of size x bits by y words has been described for managing $y-2$ link lists of data, it will be appreciated that the management RAM could assume different sizes. Thus, for example, instead of using a separate word for the unused block pointer, the unused block pointer could be located in the "tail pointer" location of the free list (which itself does not use a tail pointer), thereby providing a management RAM of x bits by y words for managing $y-1$ link lists of data. In addition, rather than providing the information related to the link lists with the head pointer, tail pointer, block counter, and queue empty flag in that order, the variables of the link list could be reordered. Similarly, instead of providing a shared memory having pages of thirty-two words in depth, each word being sixteen bits in length, it will be appreciated that memories of different lengths and depths could be utilized. Also, rather than locating the pointer to the next block in the last word of the last page of a previous block, it will be appreciated that the pointer could be located in a different location. Further yet, while specific flow charts have been disclosed with respect to various operations, it will be appreciated that various aspects of the operations can be conducted in different orders. In addition, while particular code has been disclosed for generating gate arrays which conduct the operations in hardware, it should be appreciated by those skilled in the art that other code can be utilized to generate hardware, and that hardware and/or firmware can be generated in

different manners. Furthermore, while the invention was described with respect to separate RAMs for the management RAM and the shared data RAM, it will be appreciated that both memories may be part of a larger single memory means. It will therefore be appreciated by those skilled in the art that yet other modifications could be made to the provided invention without deviating from its spirit and scope as so claimed.

Claims:

1. Apparatus for managing the storage of data in a memory, comprising:
 - a) a shared memory means having a plurality of data storage locations;
 - b) control means for receiving said data and forwarding said data to desired of said plurality of data storage locations in said shared memory means, wherein said data is stored in said plurality of data storage locations in the form of a plurality of link lists, each link list having a head;
 - c) management memory means for storing information regarding each of said plurality of link lists, said information including a head pointer and a queue empty flag for each link list, said head pointer for each particular respective link list pointing to a location of a respective said head of that particular link list, and said queue empty flag for a link list indicating that that link list has no valid data contained therein.
2. An apparatus according to claim 1, wherein:
 - said control means reads data from said shared memory means, at least a plurality of said data storage locations are in the form of a free link list, said free link list relating to data storage locations from which data has been read by said control means, and
 - said management memory means includes a pointer and a queue empty flag for said free link list.
3. An apparatus for managing the storage of data in a memory, comprising:
 - a) a shared memory means having a plurality of data storage locations;
 - b) control means for receiving said data and forwarding said data to desired of said plurality of data storage locations in said shared memory means, and for reading data from said shared memory means, wherein said data is stored in said plurality of data storage locations in the form of a plurality of link lists, each link list having a head;

c) management memory means for storing information regarding each of said plurality of link lists, said information including a head pointer for each link list queue, said head pointer for each particular respective link list pointing to a location of a respective said head of that particular link list,

wherein upon initialization, at least a plurality of said data storage locations of said shared memory means are unused, and after utilization, at least a plurality of said data storage locations are in the form of a free link list, said free link list relating to data storage locations from which data has been read by said control means, and

wherein said management memory means includes a pointer to at least one of said unused data storage locations, and said management memory means includes a pointer for said free link list.

4. An apparatus according to any preceding claim, wherein:

at least upon initialization, at least a plurality of said data storage locations of said shared memory means are unused, and said management memory means includes a pointer to at least one of said unused data storage locations.

5. An apparatus according to any previous claim, wherein:

said shared memory means is arranged in a plurality of blocks with each block having a plurality of said data storage locations, and

said information stored in said management memory means regarding each of said plurality of link list queues includes a block counter for each of said plurality of link list queues, each block counter counting the number of blocks contained in that link list queue.

6. An apparatus according to claim 5, wherein:

each of said plurality of blocks is arranged as a plurality of contiguous pages with each page having a plurality of said data storage locations, and

each said head pointer comprises a block pointer which points to a block and a page counter which points to a page in said block.

7. An apparatus according to claim 5, wherein:

each block storing data includes at least one location containing one of (i) a pointer to a next block in the link list, and (ii) an indicator which indicates that the block is the last block in the link list.

8. An apparatus according to claim 7, wherein:

said pointer to a next block in the link list includes a parity bit for said pointer.

9. An apparatus according to claim 6, wherein:

each block storing data includes at least one location in a last page of that block containing one of (i) a pointer to a next block in the link list, and (ii) an indicator which indicates that the block is the last block in the link list.

10. An apparatus according to any previous claim, wherein:

said information includes a tail pointer for each link list containing said data.

11. An apparatus according to claim 6, wherein:

said information includes a tail pointer for each link list containing said data,

each of said plurality of blocks is arranged as a plurality of contiguous pages with each page having a plurality of said data storage locations,

each said head pointer comprises a first block pointer which points to a block and a page counter which points to a page in said block, and

each said tail pointer comprises a second block pointer which points to a tail block and a page counter which points to a page in said tail block.

12. An apparatus according to claim 6, wherein:
said data comprises ATM data received in cell format, and each said page includes enough of said data storage locations to store all of the data contained in an ATM cell.
13. An apparatus according to claim 12, wherein:
each page includes thirty-two sixteen bit word locations.
14. An apparatus according to claim 5, wherein:
said control means reads data from said shared memory means, at least a plurality of said data storage locations are in the form of a free link list, said free link list relating to data storage locations from which data has been read by said control means, and
said management memory means includes a pointer, a block counter, and a queue empty flag for said free link list, at least a plurality of said data storage locations of said shared memory means are unused, and
said management memory means includes a pointer to said at least one of said unused data storage locations, and
said control means includes means for comparing a sum of counts of said block counters of each link list containing data, said free link list, and said unused pointer to the number of blocks in said shared memory means.
15. An apparatus according to claim 14, wherein:
said control means further comprises means for generating an error signal is said sum of counts does not equal said number of blocks in said shared memory means.
16. An apparatus according to claim 10, wherein:
said control means includes means for comparing, for each link list containing data, said tail pointer to said head pointer.

17. An apparatus according to claim 16, wherein:

said control means further comprises means for generating an error signal if said tail pointer and said head pointer for a link list containing data point to an identical block, and said block counter for said link list does not equal one.

18. An apparatus according to claim 16, wherein:

said control means further comprises means for generating an error signal if said tail pointer and said head pointer for a link list containing data point to different blocks, and said block counter for said link list equals one.

19. An apparatus according to claim 5, wherein:

said control means further comprises means for checking the count of each block counter of a link list where the queue empty flag is not set, and for generating an error signal if the count is zero and the queue empty flag is not set.

20. An apparatus according to any preceding claim, wherein:

said control means and said management memory means are contained on a single integrated circuit.

21. An apparatus according to claim 5, wherein:

said management memory means includes said pointer, a block counter, and a queue empty flag for said free link list, and said control means includes means for comparing a sum of counts of said block counters of each link list containing data, said free link list, and said unused pointer to the number of blocks in said shared memory means, and means for generating an error signal if said sum of counts does not equal said number of blocks in said shared memory means.

22. An apparatus according to claim 10, wherein:

said control means includes means for comparing, for each link list containing data, said tail pointer to said head pointer, and means for generating an error signal if either

(i) said tail pointer and said head pointer for a link list containing data point to an identical block, and said block counter for said link list does not equal one, or

(ii) said tail pointer and said head pointer for a link list containing data point to different blocks, and said block counter for said link list equals one.

23. A method of managing the storage of data utilizing a controller, a shared memory having a plurality of data storage locations, and a management memory, said method comprising:

a) using said controller to forward received data to desired of the plurality of data storage locations in the shared memory, wherein the data is stored in the plurality of data storage locations in the form of a plurality of link lists, each link list having a head; and

b) storing information regarding each of the plurality of link lists in the management memory, said information including a head pointer and a queue empty flag for each link list, said head pointer for each particular respective link list pointing to a location of a respective said head of that particular link list, and said queue empty flag for a link list indicating that that link list has no valid data contained therein.

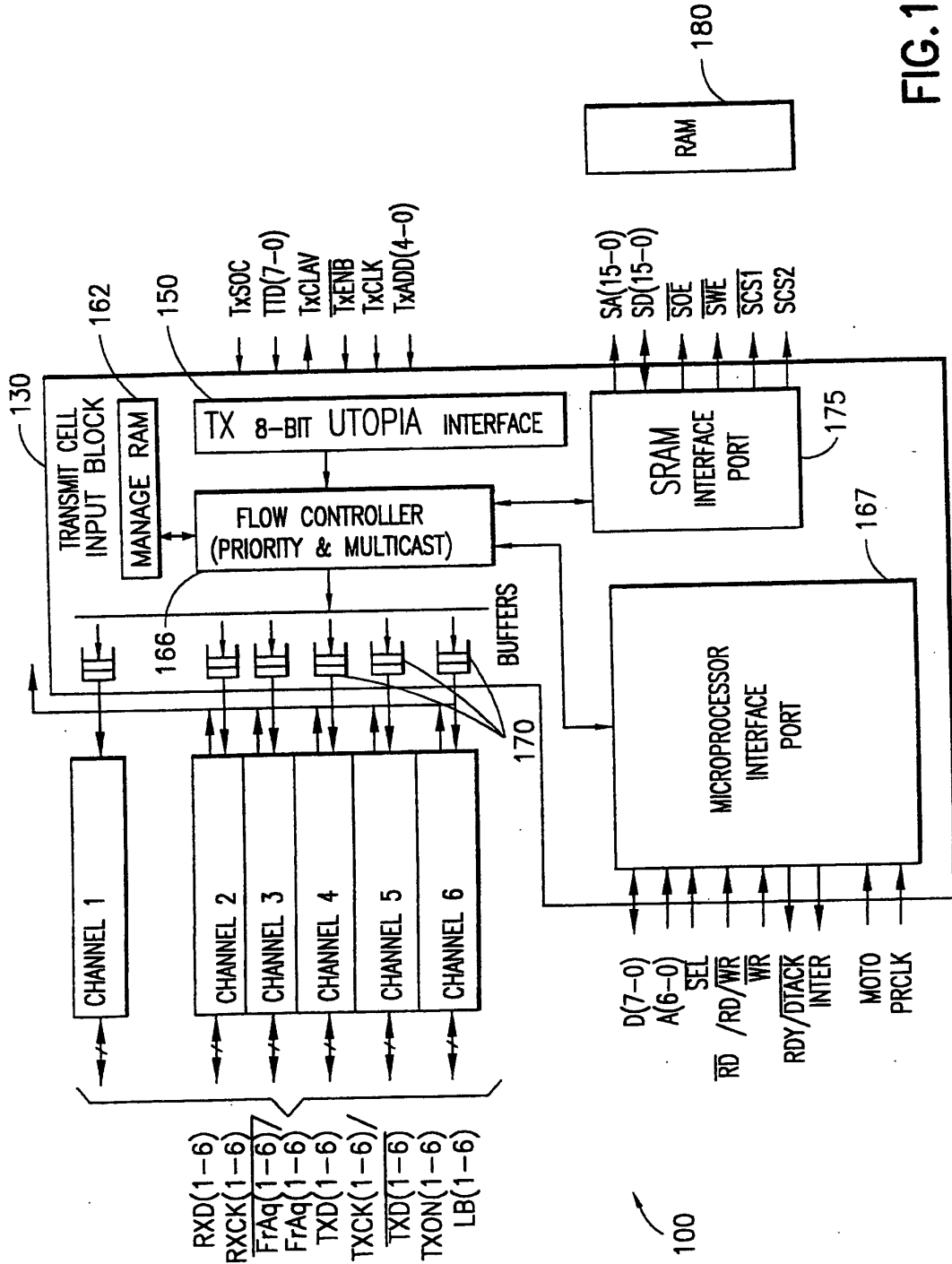

FIG. 1

SUBSTITUTE SHEET (RULE 26)

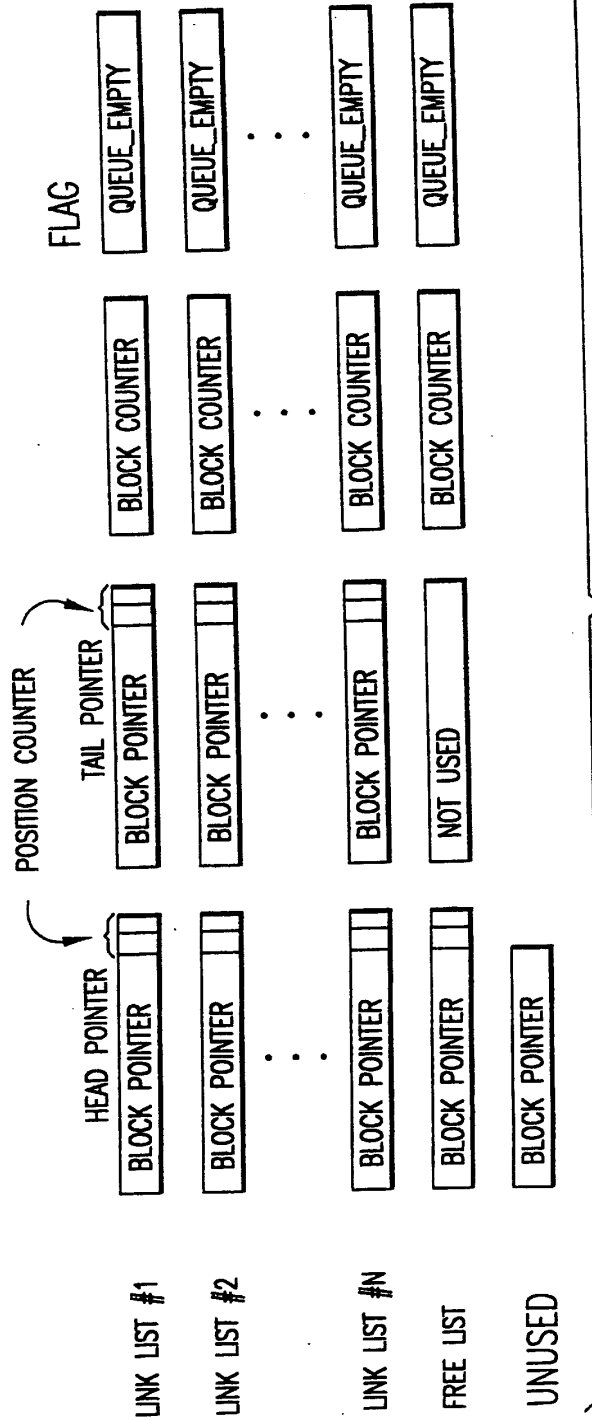

FIG.2

SUBSTITUTE SHEET (RULE 26)

3/11

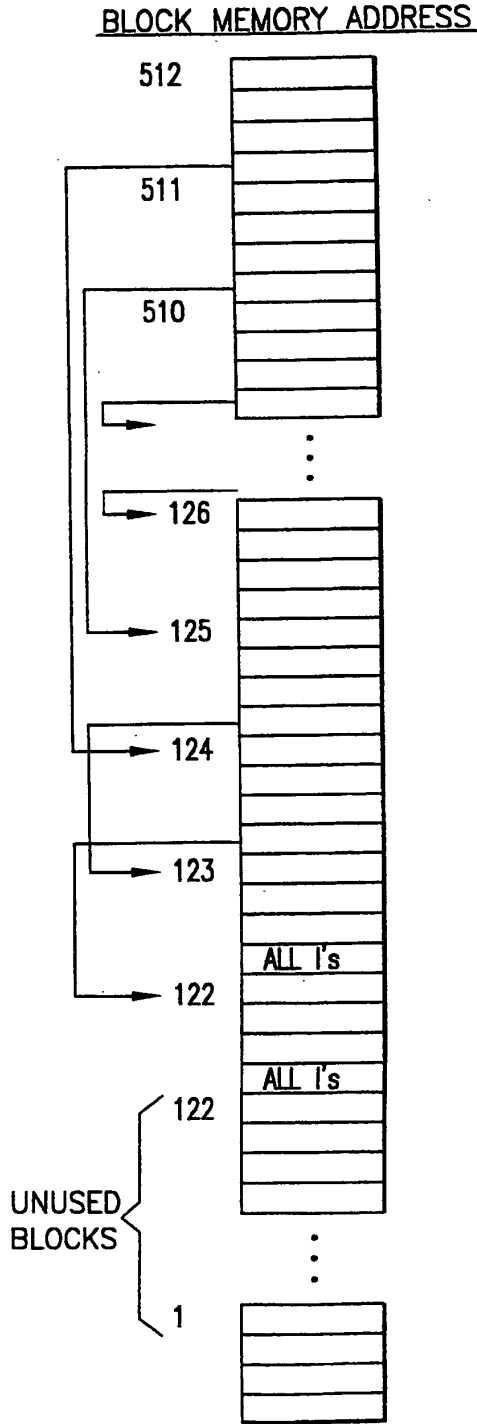

FIG.3a

SUBSTITUTE SHEET (RULE 26)

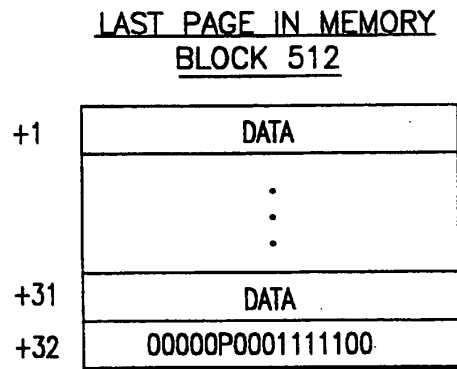

FIG.3b

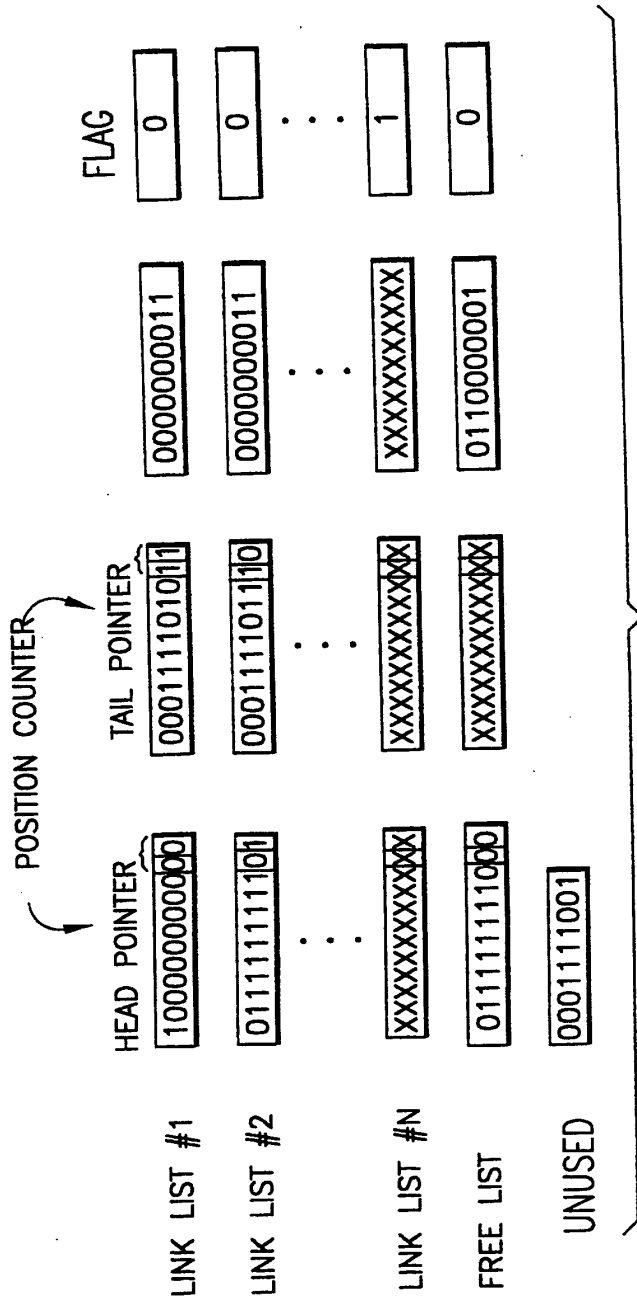

FIG.3c

SUBSTITUTE SHEET (RULE 26)

5/11

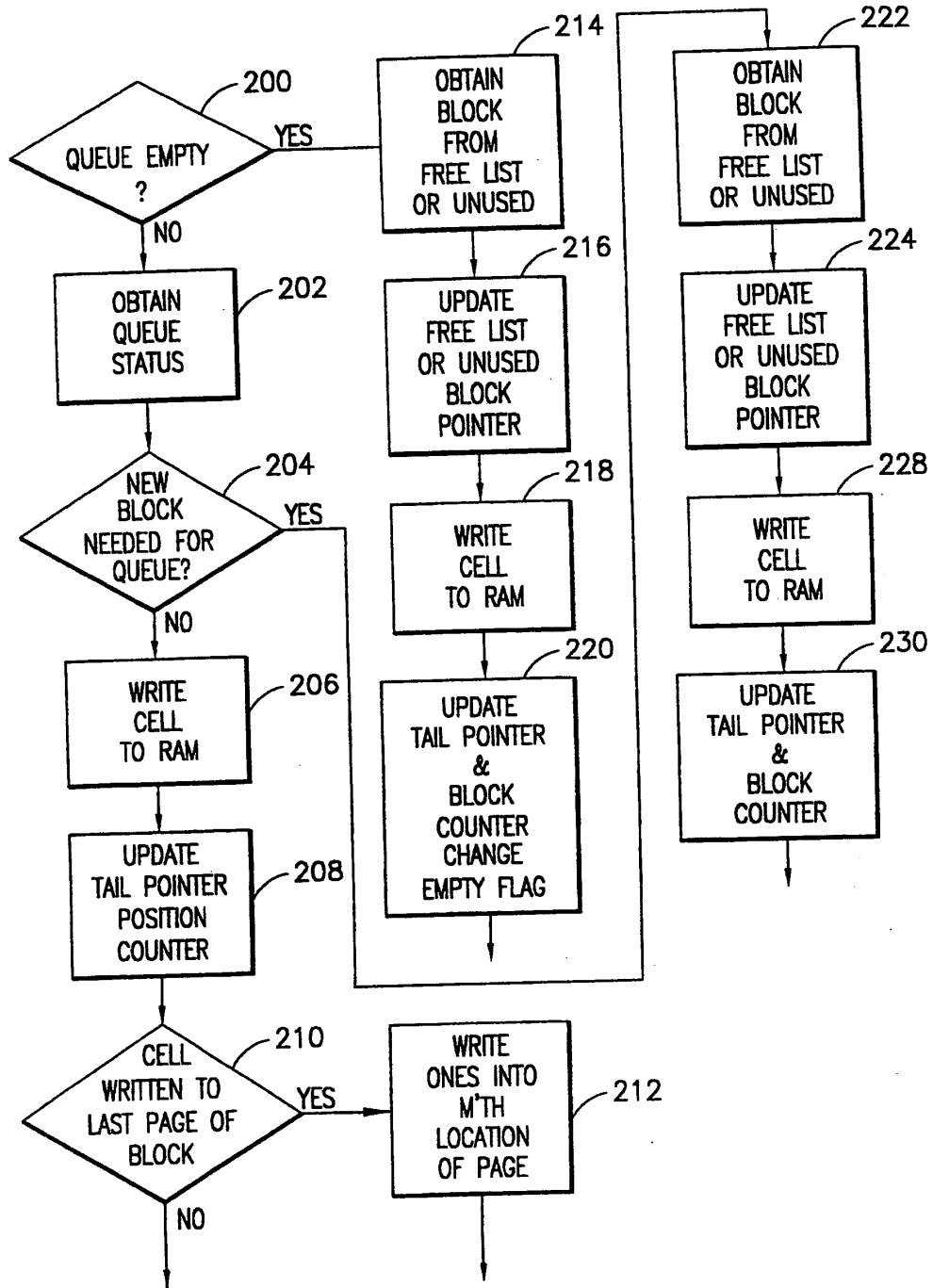

FIG.4a

SUBSTITUTE SHEET (RULE 26)

6/11

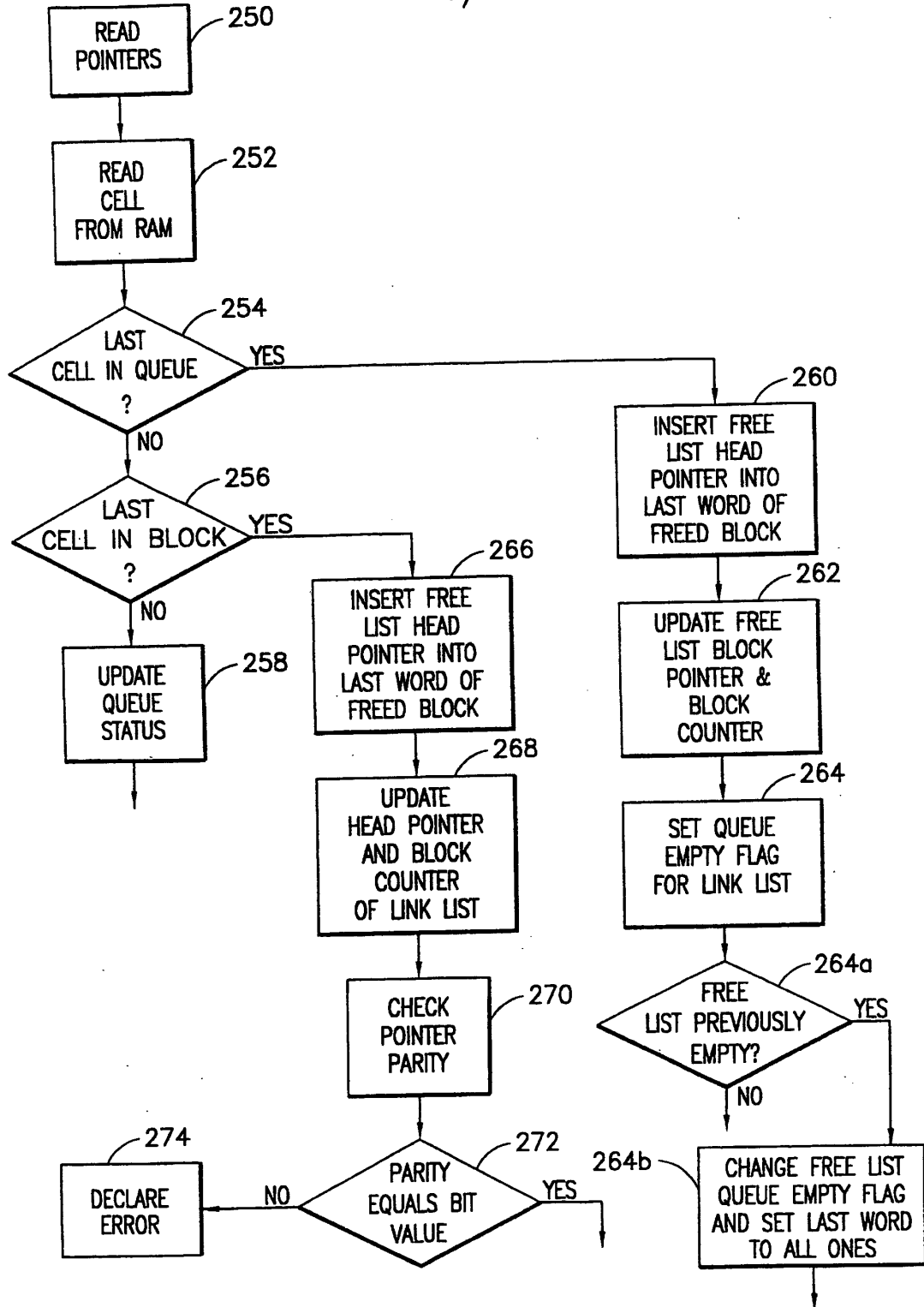

FIG. 4b
SUBSTITUTE SHEET (RULE 26)

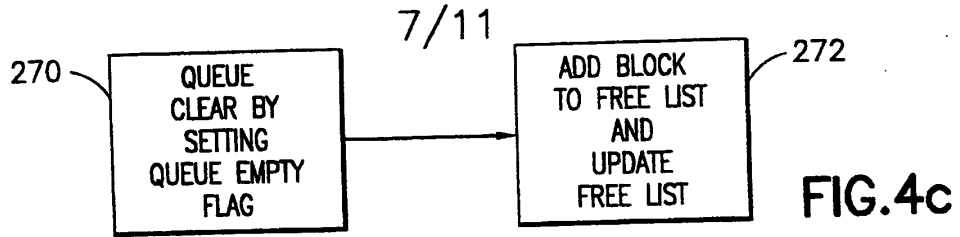

FIG.4c

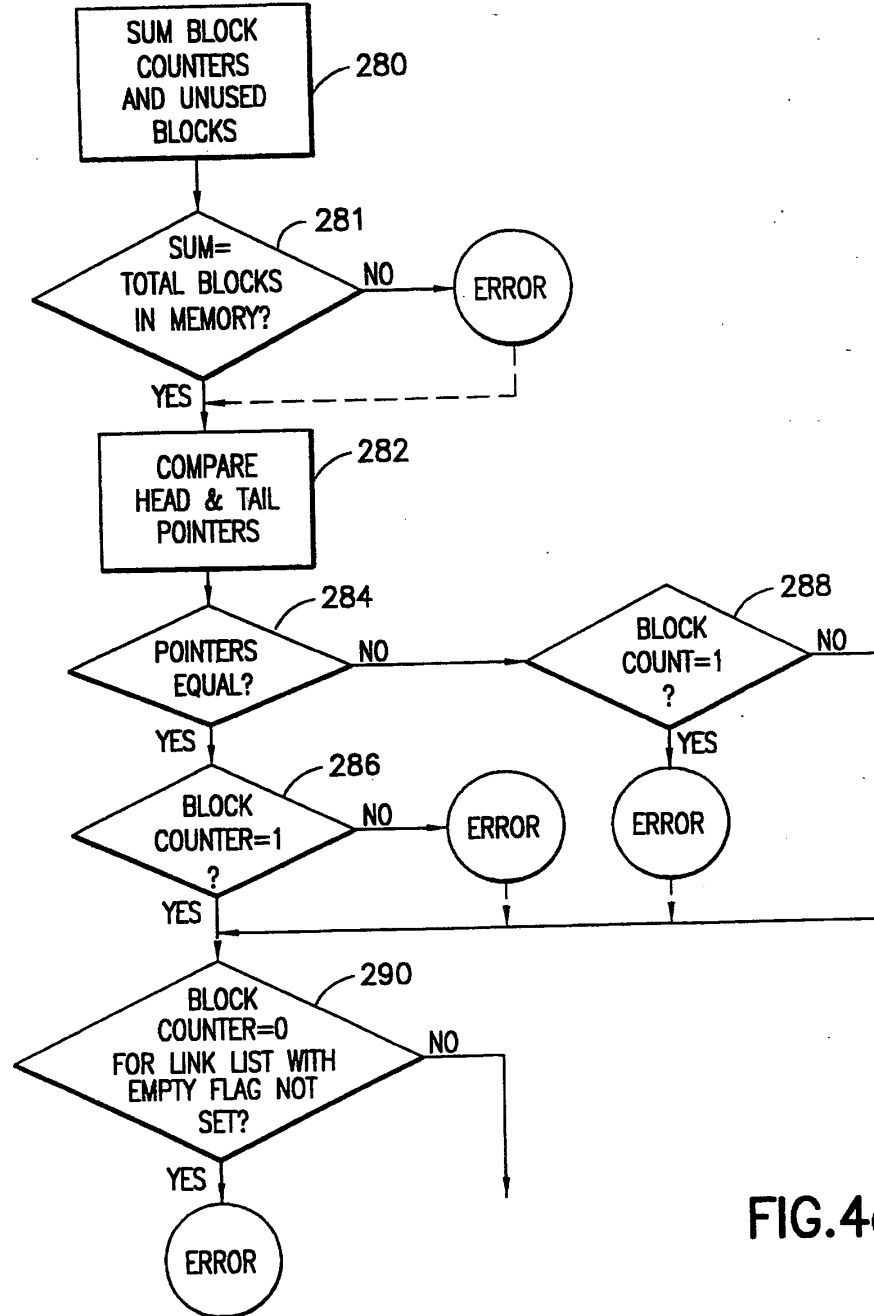

FIG.4d

SUBSTITUTE SHEET (RULE 26)

8/11

WRITE STATE MACHINE

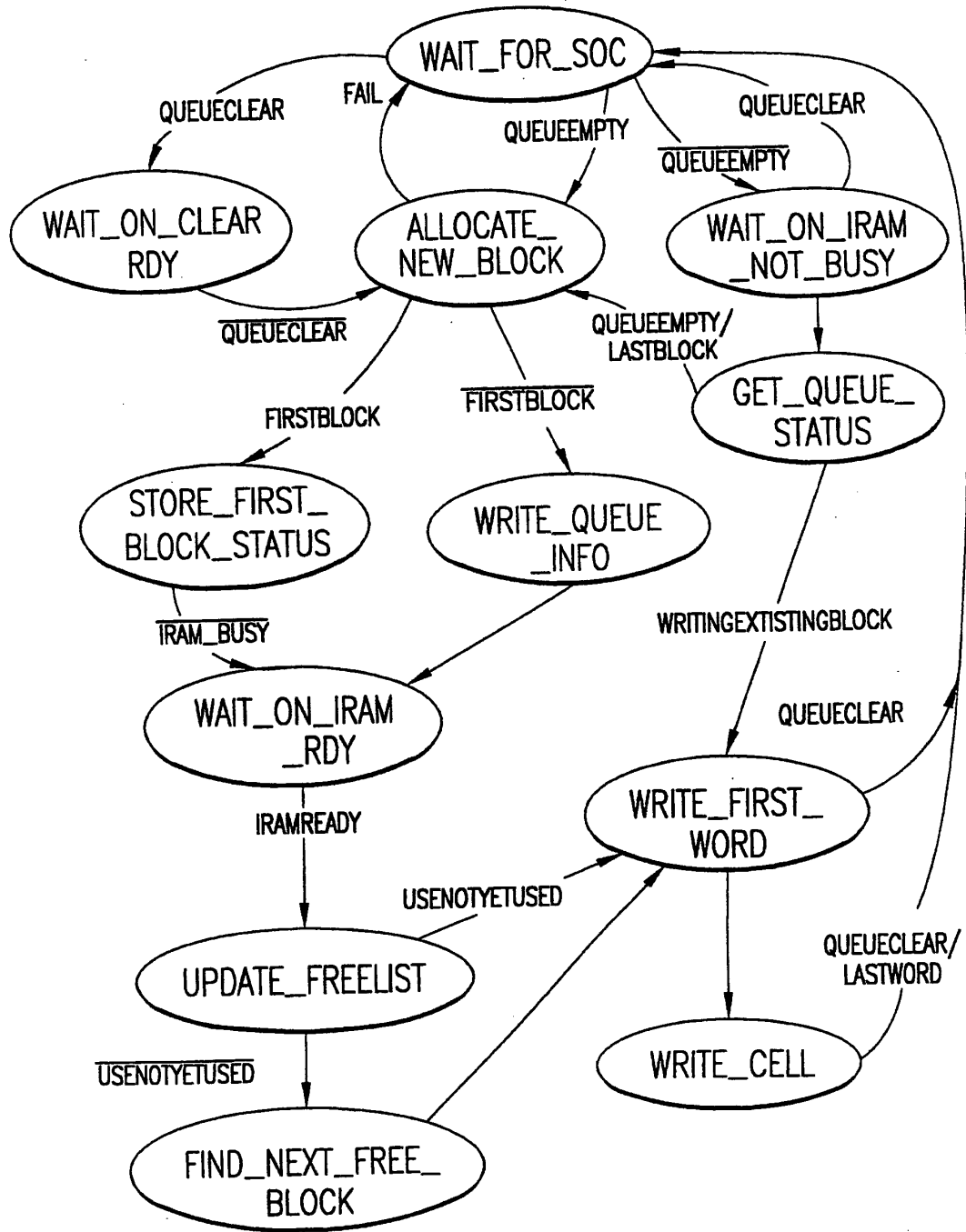

FIG.5a

SUBSTITUTE SHEET (RULE 26)

9/11

READ STATE MACHINE

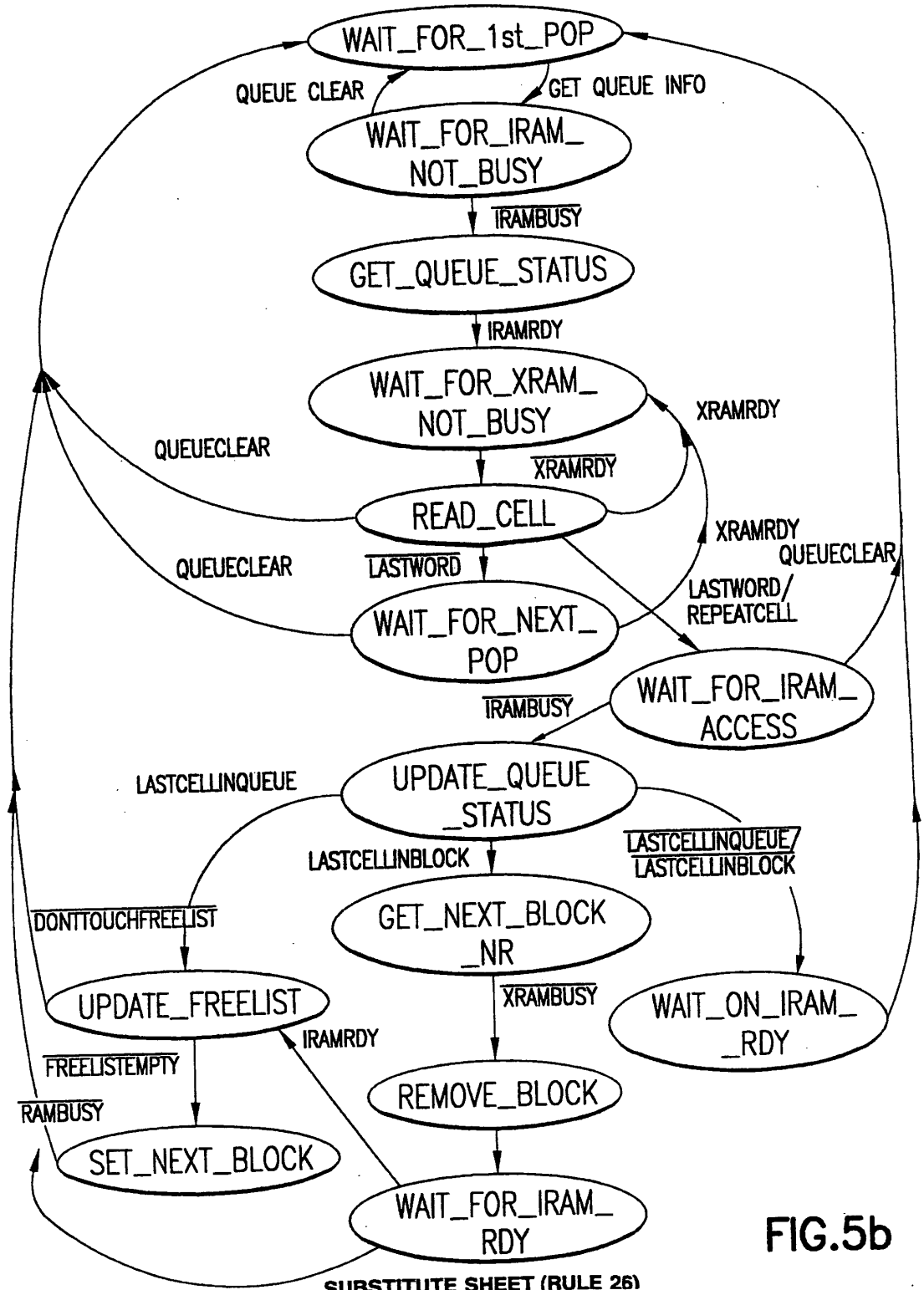

FIG.5b

SUBSTITUTE SHEET (RULE 26)

10/11

CLEAR STATE MACHINE

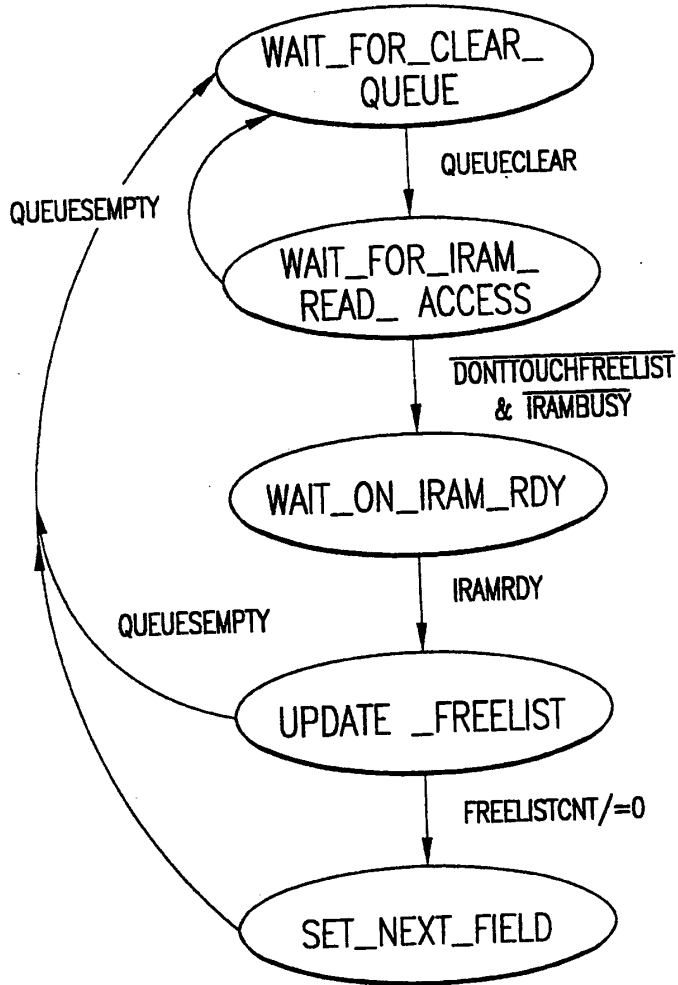

FIG.5c

SUBSTITUTE SHEET (RULE 26)

11/11

MONITORING STATE MACHINE

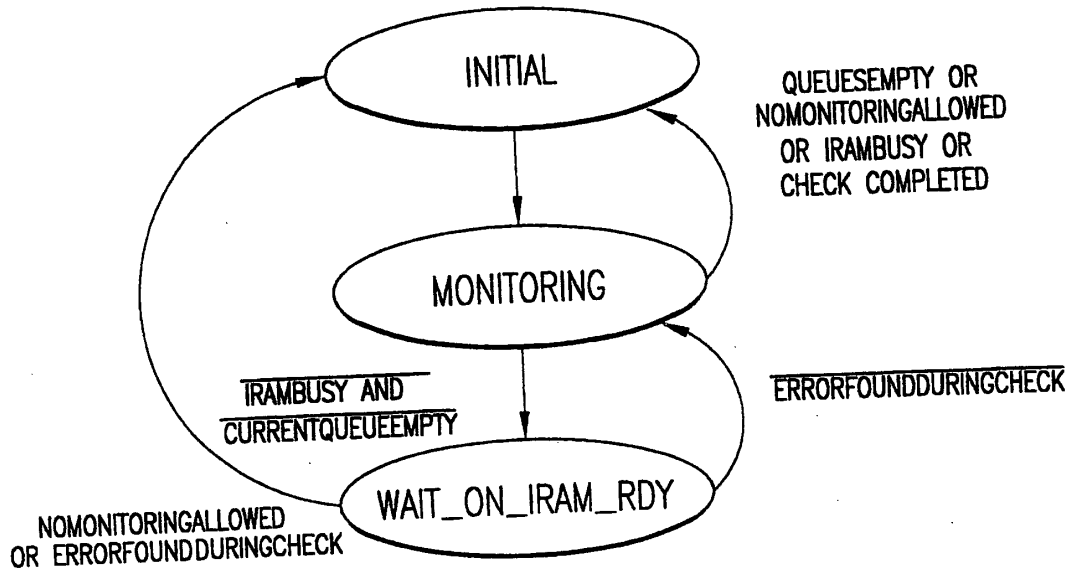

FIG.5d

SUBSTITUTE SHEET (RULE 26)

INTERNATIONAL SEARCH REPORT

International application No.
PCT/US98/02131

A. CLASSIFICATION OF SUBJECT MATTER
 IPC(6) :G06F 12/00
 US CL :711/153
 According to International Patent Classification (IPC) or to both national classification and IPC

B. FIELDS SEARCHED
 Minimum documentation searched (classification system followed by classification symbols)
 U.S. : 711/153, 711/207, 370/232, 370/398

Documentation searched other than minimum documentation to the extent that such documents are included in the fields searched

Electronic data base consulted during the international search (name of data base and, where practicable, search terms used)
 APS, MAYA

C. DOCUMENTS CONSIDERED TO BE RELEVANT

Category*	Citation of document, with indication, where appropriate, of the relevant passages	Relevant to claim No.
X ---	US 5,390,175 A (HILLER ET AL.) 14 February 1995, col. 45, line 10; Fig. 24; col. 37, line 20; col. 37, line 25; col. 21, line 35; col. 22, line 37; col 20, line 63; col. 54, line 34; col. 55, line 53; col. 35, line 56; col. 21, line 60; col. 37, line 19; col. 35, line 56	1-5, 7, 8, 10, 14-19, 20, 21, 22, 23
Y		6, 9, 11-13
Y	US 5,123,101 A (SINDHU) 16 June 1992, col. 21, line 68.	6, 9, 11-13
A, P	US 5,654,962 A (ROSTOKER ET AL) 05 August 1997	1-23

Further documents are listed in the continuation of Box C. See patent family annex.

* Special categories of cited documents:

- *A* document defining the general state of the art which is not considered to be of particular relevance
- *E* earlier document published on or after the international filing date
- *L* document which may throw doubts on priority claim(s) or which is cited to establish the publication date of another citation or other special reason (as specified)
- *O* document referring to an oral disclosure, use, exhibition or other means
- *P* document published prior to the international filing date but later than the priority date claimed
- *T* later document published after the international filing date or priority date and not in conflict with the application but cited to understand the principle or theory underlying the invention
- *X* document of particular relevance; the claimed invention cannot be considered novel or cannot be considered to involve an inventive step when the document is taken alone
- *Y* document of particular relevance; the claimed invention cannot be considered to involve an inventive step when the document is combined with one or more other such documents, such combination being obvious to a person skilled in the art
- *G* document member of the same patent family

Date of the actual completion of the international search: 30 MARCH 1998

Date of mailing of the international search report: 04 AUG 1998

Name and mailing address of the ISA/US Commissioner of Patents and Trademarks
 Box PCT
 Washington, D.C. 20231
 Facsimile No. (703) 305-3230

Authorized officer: DAVID LANGJAHR
 Telephone No. (703) 305-4034

**This Page is Inserted by IFW Indexing and Scanning
Operations and is not part of the Official Record**

BEST AVAILABLE IMAGES

Defective images within this document are accurate representations of the original documents submitted by the applicant.

Defects in the images include but are not limited to the items checked:

- BLACK BORDERS
- IMAGE CUT OFF AT TOP, BOTTOM OR SIDES
- FADED TEXT OR DRAWING
- BLURRED OR ILLEGIBLE TEXT OR DRAWING
- SKEWED/SLANTED IMAGES
- COLOR OR BLACK AND WHITE PHOTOGRAPHS
- GRAY SCALE DOCUMENTS
- LINES OR MARKS ON ORIGINAL DOCUMENT
- REFERENCE(S) OR EXHIBIT(S) SUBMITTED ARE POOR QUALITY
- OTHER: _____

IMAGES ARE BEST AVAILABLE COPY.

As rescanning these documents will not correct the image problems checked, please do not report these problems to the IFW Image Problem Mailbox.

ARTIFACT SHEET

Enter artifact number below. Artifact number is application number + artifact type code (see list below) + sequential letter (A, B, C ...). The first artifact folder for an artifact type receives the letter A, the second B, etc..
Examples: 59123456PA, 59123456PB, 59123456ZA, 59123456ZB

10658163 ZA

Indicate quantity of a single type of artifact received but not scanned. Create individual artifact folder/box and artifact number for each Artifact Type.

- CD(s) containing:
- computer program listing
Doc Code: Computer Artifact Type Code: P
 - pages of specification
and/or sequence listing
and/or table
Doc Code: Artifact Artifact Type Code: S
 - content unspecified or combined
Doc Code: Artifact Artifact Type Code: U

- Stapled Set(s) Color Documents or B/W Photographs
Doc Code: Artifact Artifact Type Code: C

- Microfilm(s)
Doc Code: Artifact Artifact Type Code: F

- Video tape(s)
Doc Code: Artifact Artifact Type Code: V

- Model(s)
Doc Code: Artifact Artifact Type Code: M

- Bound Document(s)
Doc Code: Artifact Artifact Type Code: B

- Confidential Information Disclosure Statement or Other Documents marked Proprietary, Trade Secrets, Subject to Protective Order, Material Submitted under MPEP 724.02, etc.
Doc Code: Artifact Artifact Type Code X

- Other, description: 1 NPR
Doc Code: Artifact Artifact Type Code: Z

March 8, 2004

ARTIFACT SHEET

Enter artifact number below. Artifact number is application number + artifact type code (see list below) + sequential letter (A, B, C ...). The first artifact folder for an artifact type receives the letter A, the second B, etc..
Examples: 59123456PA, 59123456PB, 59123456ZA, 59123456ZB

10658163 UA

Indicate quantity of a single type of artifact received but not scanned. Create individual artifact folder/box and artifact number for each Artifact Type.

CD(s) containing:

computer program listing

Doc Code: Computer

Artifact Type Code: P

pages of specification

and/or sequence listing

and/or table

Doc Code: Artifact

Artifact Type Code: S

content unspecified or combined

Doc Code: Artifact

Artifact Type Code: U

Stapled Set(s) Color Documents or B/W Photographs

Doc Code: Artifact Artifact Type Code: C

Microfilm(s)

Doc Code: Artifact Artifact Type Code: F

Video tape(s)

Doc Code: Artifact Artifact Type Code: V

Model(s)

Doc Code: Artifact Artifact Type Code: M

Bound Document(s)

Doc Code: Artifact Artifact Type Code: B

Confidential Information Disclosure Statement or Other Documents
marked Proprietary, Trade Secrets, Subject to Protective Order,
Material Submitted under MPEP 724.02, etc.

Doc Code: Artifact Artifact Type Code X

Other, description: _____

Doc Code: Artifact Artifact Type Code: Z

March 8, 2004



UNITED STATES PATENT AND TRADEMARK OFFICE

CO

UNITED STATES DEPARTMENT OF COMMERCE
United States Patent and Trademark Office
Address: COMMISSIONER FOR PATENTS
P.O. Box 1450
Alexandria, Virginia 22313-1450
www.uspto.gov

APPLICATION NO.	FILING DATE	FIRST NAMED INVENTOR	ATTORNEY DOCKET NO.	CONFIRMATION NO.
10/658,163	09/09/2003	Geoffrey B. Hoese	CROSS1120-13	5675
25094	7590	01/27/2005	EXAMINER	
DLA PIPER RUDNICK GRAY CARY US, LLP			SHIN, CHRISTOPHER B	
2000 University Avenue			ART UNIT	
E. Palo Alto, CA 94303-2248			PAPER NUMBER	

2182

DATE MAILED: 01/27/2005

Please find below and/or attached an Office communication concerning this application or proceeding.

Office Action Summary	Application No. 10/658,163	Applicant(s) HOESE ET AL.	
	Examiner Christopher B Shin	Art Unit 2182	

-- The MAILING DATE of this communication appears on the cover sheet with the correspondence address --

Period for Reply

A SHORTENED STATUTORY PERIOD FOR REPLY IS SET TO EXPIRE 3 MONTH(S) FROM THE MAILING DATE OF THIS COMMUNICATION.

- Extensions of time may be available under the provisions of 37 CFR 1.136(a). In no event, however, may a reply be timely filed after SIX (6) MONTHS from the mailing date of this communication.
- If the period for reply specified above is less than thirty (30) days, a reply within the statutory minimum of thirty (30) days will be considered timely.
- If NO period for reply is specified above, the maximum statutory period will apply and will expire SIX (6) MONTHS from the mailing date of this communication.
- Failure to reply within the set or extended period for reply will, by statute, cause the application to become ABANDONED (35 U.S.C. § 133). Any reply received by the Office later than three months after the mailing date of this communication, even if timely filed, may reduce any earned patent term adjustment. See 37 CFR 1.704(b).

Status

- 1) Responsive to communication(s) filed on _____.
- 2a) This action is **FINAL**. 2b) This action is non-final.
- 3) Since this application is in condition for allowance except for formal matters, prosecution as to the merits is closed in accordance with the practice under *Ex parte Quayle*, 1935 C.D. 11, 453 O.G. 213.

Disposition of Claims

- 4) Claim(s) 15-53 is/are pending in the application.
4a) Of the above claim(s) _____ is/are withdrawn from consideration.
- 5) Claim(s) _____ is/are allowed.
- 6) Claim(s) 15-53 is/are rejected.
- 7) Claim(s) _____ is/are objected to.
- 8) Claim(s) _____ are subject to restriction and/or election requirement.

Application Papers

- 9) The specification is objected to by the Examiner.
- 10) The drawing(s) filed on 09 September 2003 is/are: a) accepted or b) objected to by the Examiner.
Applicant may not request that any objection to the drawing(s) be held in abeyance. See 37 CFR 1.85(a).
Replacement drawing sheet(s) including the correction is required if the drawing(s) is objected to. See 37 CFR 1.121(d).
- 11) The oath or declaration is objected to by the Examiner. Note the attached Office Action or form PTO-152.

Priority under 35 U.S.C. § 119

- 12) Acknowledgment is made of a claim for foreign priority under 35 U.S.C. § 119(a)-(d) or (f).
a) All b) Some * c) None of:
1. Certified copies of the priority documents have been received.
2. Certified copies of the priority documents have been received in Application No. _____.
3. Copies of the certified copies of the priority documents have been received in this National Stage application from the International Bureau (PCT Rule 17.2(a)).
- * See the attached detailed Office action for a list of the certified copies not received.

Attachment(s)

- | | |
|---|---|
| 1) <input checked="" type="checkbox"/> Notice of References Cited (PTO-892) | 4) <input type="checkbox"/> Interview Summary (PTO-413)
Paper No(s)/Mail Date. _____ |
| 2) <input type="checkbox"/> Notice of Draftsperson's Patent Drawing Review (PTO-948) | 5) <input type="checkbox"/> Notice of Informal Patent Application (PTO-152) |
| 3) <input checked="" type="checkbox"/> Information Disclosure Statement(s) (PTO-1449 or PTO/SB/08)
Paper No(s)/Mail Date <u>2,4 & 5/2004</u> . | 6) <input type="checkbox"/> Other: _____ |

DETAILED ACTION

Drawings

1. The drawings are objected to under 37 CFR 1.83(a). The drawings must show every feature of the invention specified in the claims. Therefore, the gist of the claimed limitation regarding the first & second mediums being a Fibre Channel protocol type, without adding any new matter, must be shown or the feature(s) canceled from the claim(s). No new matter should be entered.
2. Corrected drawing sheets in compliance with 37 CFR 1.121(d) are required in reply to the Office action to avoid abandonment of the application. Any amended replacement drawing sheet should include all of the figures appearing on the immediate prior version of the sheet, even if only one figure is being amended. The figure or figure number of an amended drawing should not be labeled as "amended." If a drawing figure is to be canceled, the appropriate figure must be removed from the replacement sheet, and where necessary, the remaining figures must be renumbered and appropriate changes made to the brief description of the several views of the drawings for consistency. Additional replacement sheets may be necessary to show the renumbering of the remaining figures. The replacement sheet(s) should be labeled "Replacement Sheet" in the page header (as per 37 CFR 1.84(c)) so as not to obstruct any portion of the drawing figures. If the changes are not accepted by the examiner, the applicant will be notified and informed of any required corrective action in the next Office action. The objection to the drawings will not be held in abeyance.

3. The drawings are objected to under 37 CFR 1.83(a) because they fail to show the claimed limitation regarding the first & second mediums being a Fibre Channel protocol type, without adding any new matter, as described in the specification. Any structural detail that is essential for a proper understanding of the disclosed invention should be shown in the drawing. MPEP § 608.02(d). Corrected drawing sheets in compliance with 37 CFR 1.121(d) are required in reply to the Office action to avoid abandonment of the application. Any amended replacement drawing sheet should include all of the figures appearing on the immediate prior version of the sheet, even if only one figure is being amended. The figure or figure number of an amended drawing should not be labeled as "amended." If a drawing figure is to be canceled, the appropriate figure must be removed from the replacement sheet, and where necessary, the remaining figures must be renumbered and appropriate changes made to the brief description of the several views of the drawings for consistency. Additional replacement sheets may be necessary to show the renumbering of the remaining figures. The replacement sheet(s) should be labeled "Replacement Sheet" in the page header (as per 37 CFR 1.84(c)) so as not to obstruct any portion of the drawing figures. If the changes are not accepted by the examiner, the applicant will be notified and informed of any required corrective action in the next Office action. The objection to the drawings will not be held in abeyance.

Specification

4. The abstract of the disclosure is objected to because the gist of the present claimed invention regarding the first & second transport mediums being a Fibre Channel protocol is not accurately disclosed by the abstract. Correction is required. See MPEP § 608.01(b).

5. The disclosure is objected to because of the following informalities: the entire disclosure does not accurately disclose the gist of the present claimed invention regarding the first & second transport medium being Fibre Channel protocol type. This applies to all of the sections of the disclosure.

Appropriate correction is required.

Unclear Claimed Definition

6. IN an attempt to expedite prosecution, numerous telephone interview attempts were made to clarify the following questions on January 18th, 19th, & 20th of 2005 to the attorney of record, but the examiner was unable to reach the attorney.

7. After careful consideration of the present claims 15-53, the examiner would like the applicant to clearly and explicitly define the following terms/questions in two parts.

a. First part-clear and explicit indented definition of the following terms in accordance with the support of the specification; and

b. Second part-detailed sections of the specifications that supports the following terms which the applicant relies on for the support of the claims 15-53.

i. "mapping";

- ii. native low level, block protocols; and
 - iii. first transport & second transport medium being both Fibre Channel Protocol.
- c. The applicant's cooperation would be greatly appreciated. Failure to respond answer may cause delay and/or improper interpretation of the present claims.

Claim Rejections - 35 USC § 112

8. The following is a quotation of the first paragraph of 35 U.S.C. 112:

The specification shall contain a written description of the invention, and of the manner and process of making and using it, in such full, clear, concise, and exact terms as to enable any person skilled in the art to which it pertains, or with which it is most nearly connected, to make and use the same and shall set forth the best mode contemplated by the inventor of carrying out his invention.

9. Claims 15-53 are rejected under 35 U.S.C. 112, first paragraph, because the best mode contemplated by the inventor has not been disclosed. Evidence of concealment of the best mode is based upon the fact that the disclosure does not clearly disclose any details of the present claims regarding the first & second mediums being both Fibre Channel transport as a whole.

10. Claims 15-53 are rejected under 35 U.S.C. 112, first paragraph, as failing to comply with the enablement requirement. The claim(s) contains subject matter which was not described in the specification in such a way as to enable one skilled in the art to which it pertains, or with which it is most nearly connected, to make and/or use the invention. The disclosure does not clearly disclose any details of the present claims regarding the first & second mediums being both Fibre Channel transport as a whole.

11. Claims 15-53 are rejected under 35 U.S.C. 112, first paragraph, as based on a disclosure which is not enabling. The disclosure does not clearly disclose any details of the present claims regarding the first & second mediums being both Fibre Channel transport as a whole is critical or essential to the practice of the invention, but not included in the claim(s) is not enabled by the disclosure. See *In re Mayhew*, 527 F.2d 1229, 188 USPQ 356 (CCPA 1976).

12. Claims 15-53 are rejected under 35 U.S.C. 112, first paragraph, because the specification, while being enabling for the first and second mediums being different types of transport medium as disclosed in the specification, does not reasonably provide enablement for the details of the present claims regarding the first & second mediums being both Fibre Channel transport as a whole. The specification does not enable any person skilled in the art to which it pertains, or with which it is most nearly connected, to support the invention commensurate in scope with these claims.

Double Patenting Rejection

13. The nonstatutory double patenting rejection is based on a judicially created doctrine grounded in public policy (a policy reflected in the statute) so as to prevent the unjustified or improper timewise extension of the "right to exclude" granted by a patent and to prevent possible harassment by multiple assignees. See *In re Goodman*, 11 F.3d 1046, 29 USPQ2d 2010 (Fed. Cir. 1993); *In re Longi*, 759 F.2d 887, 225 USPQ 645 (Fed. Cir. 1985); *In re Van Ornum*, 686 F.2d 937, 214 USPQ 761 (CCPA 1982); *In re Vogel*, 422 F.2d 438, 164 USPQ 619 (CCPA 1970); and, *In re Thorington*, 418 F.2d 528, 163 USPQ 644 (CCPA 1969).

A timely filed terminal disclaimer in compliance with 37 CFR 1.321(c) may be used to overcome an actual or provisional rejection based on a nonstatutory double patenting ground provided the conflicting application or patent is shown to be commonly owned with this application. See 37 CFR 1.130(b).

Effective January 1, 1994, a registered attorney or agent of record may sign a terminal disclaimer. A terminal disclaimer signed by the assignee must fully comply with 37 CFR 3.73(b).

14. Claim 15-53 are rejected under the judicially created doctrine of obviousness-type double patenting as being unpatentable over claims 1-14 of U.S. Patent No. 5,941,972. Although the conflicting claims are not identical, they are not patentably distinct from each other because the 972 patent claims a subject matter that are substantially identical to the present claimed invention.

15. Claim 15-53 are rejected under the judicially created doctrine of obviousness-type double patenting as being unpatentable over claims 1-14 of U.S. Patent No. 6,425,035. Although the conflicting claims are not identical, they are not patentably distinct from each other because the 035 patent claims a subject matter that are substantially identical to the present claimed invention.

16. Claim 15-53 are rejected under the judicially created doctrine of obviousness-type double patenting as being unpatentable over claims 1-23 of U.S. Patent No. 6,738,854. Although the conflicting claims are not identical, they are not patentably distinct from each other because the 972 patent claims a subject matter that are substantially identical to the present claimed invention.

17. Claim 15-53 are rejected under the judicially created doctrine of obviousness-type double patenting as being unpatentable over claims 1-10 of U.S. Patent No. 6,763,419. Although the conflicting claims are not identical, they are not patentably distinct from each other because the 419 patent claims a subject matter that are substantially identical to the present claimed invention.

Any inquiry concerning this communication or earlier communications from the examiner should be directed to Christopher B Shin whose telephone number is 571-272-4159. The examiner can normally be reached on 6:30-5:00 M,Tu,Th,F.







If attempts to reach the examiner by telephone are unsuccessful, the examiner's supervisor, Jeffrey Gaffin can be reached on 703-308-3301. The fax phone number for the organization where this application or proceeding is assigned is 571-272-4146

Information regarding the status of an application may be obtained from the Patent Application Information Retrieval (PAIR) system. Status information for published applications may be obtained from either Private PAIR or Public PAIR. Status information for unpublished applications is available through Private PAIR only. For more information about the PAIR system, see <http://pair-direct.uspto.gov>. Should you have questions on access to the Private PAIR system, contact the Electronic Business Center (EBC) at 866-217-9197 (toll-free).

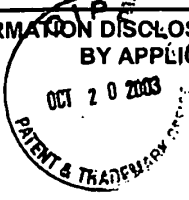
Christopher Shin
Primary Examiner
Of 2182

January 21, 2005
CBS



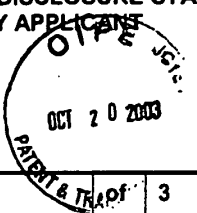

INFORMATION DISCLOSURE STATEMENT BY APPLICANT				Application Number	10/658,163		
				Filing Date	September 9, 2003		
				First Named Inventor	Geoffrey Hoese RECEIVED		
				Group Art Unit	Unknown OCT 22 2003		
				Examiner Name	Unknown		
Sheet	1	of	3	Attorney Ref. Number	CROSS1120-13 Technology Center 2100		
U.S. PATENT DOCUMENTS							
Examiner Initials	Cite No.	Document Number		Publication Date MM-DD- YYYY	Name of Patentee or Applicant of Cited Document	Pages, Columns, Lines Where Relevant Passages or Figures Appear	
		Number	Kind Code (if known)				
 	A1	5,748,924	--	05/05/98	Llorens, et al.		
	A2	5,768,623	--	06/16/98	Judd, et al.		
	A3	5,809,328	--	09/15/98	Nogales, et al.		
	A4	5,812,754	--	09/22/98	Lui, et al.		
	A5	5,835,496	--	11/10/98	Yeung, et al.		
	A6	5,848,251	--	12/08/98	Lomelino, et al.		
	A7	5,941,972	--	08/24/99	Hoese, et al.		
	A8	6,041,381	--	03/21/00	Hoese		
	A9	6,145,006	--	11/07/00	Vishlitsky et al.		
	A10	6,219,771		B1	04/17/01	Kikuchi et al.	
	A11	6,260,120		B1	07/10/01	Blumenau et al.	
	A12	3,082,406		--	03/19/63	L.D. Stevens	
	A13	4,092,732		--	05/30/78	Ouchi	
	A14	4,947,367		--	08/07/90	Chang et al.	
	A15	5,072,378		--	12/10/91	Manka	
	A16	5,465,382		--	11/07/95	Day, III et al.	
	A17	5,947,530		--	10/26/99	Young	
	A18	6,529,996		B1	03/04/03	Nguyen et al.	
FOREIGN PATENT DOCUMENTS							
Examiner Initials	Cite No.	Country		Publication Date MM-DD- YYYY (Number 43)	Name of Patentee or Applicant of Cited Document	Pages, Columns, Lines Where Relevant Passages or Figures Appear	
		Code	Number				Kind Code (if known)
 	B1	EP	0827059	A2	03/04/98	NEC Corporation	
	B2	JP	8-230895	--	09/10/96	Kikuchi et al.	
	B3	WO	99/34297	A1	07/08/99	Crossroads Systems, Inc.	
	B4	EP	0810 530	A2	12/03/97	Sun Microsystems, Inc.	
Examiner Signature					Date Considered	1-18-05	

INFORMATION DISCLOSURE STATEMENT BY APPLICANT 		Application Number	Unknown	RECEIVED OCT 22 2003 Technology Center 2100
		Filing Date	Herewith	
		First Named Inventor	Ge ffrey H ese	
		Group Art Unit	Unknown	
		Examiner Name	Unknown	
Sheet	3	Attorney Ref. Number	CROSS1120-10	



U.S. PATENT DOCUMENTS



Examiner Initials	Cite No.	Document Number		Publication Date MM-DD-YYYY	Name of Patentee or Applicant of Cited Document	Pages, Columns, Lines Where Relevant Passages or Figures Appear
		Number	Kind Code (if known)			
	A40	5,347,384	--	09/13/94	McReynolds et al.	
	A41	5,423,044	--	06/06/95	Sutton et al.	
	A42	5,239,643	--	08/24/93	Blount et al.	
	A43	5,712,976	--	01/27/98	Falcon, Jr. et al.	
	A44	5,596,736	--	01/21/97	Kerns	
	A45	6,141,737	--	10/31/00	Krantz et al.	
	A46	4,751,635	--	06/14/88	Kret	
	A47	5,596,562	--	06/21/97	Chen	
	A48	6,363,462	B1	03/26/02	Bergsten	
	A49	6,134,617	--	10/17/00	Weber	
	A50	6,073,209	--	06/06/00	Bergsten	
Examiner Signature				Date Considered	1-18-05	

INFORMATION DISCLOSURE STATEMENT BY APPLICANT 			Application Number	Unknown	
			Filing Date	Herewith	
			First Named Inventor	Geoffrey Hoese RECEIVED	
			Group Art Unit	Unknown OCT 22 2003	
Examiner Name	Unknown				
Sheet	2	of	3	Attorney Ref. Number	CROSS1120-10 Technology Center 2100

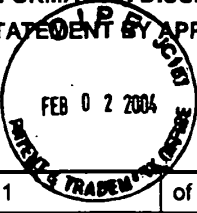
U.S. PATENT DOCUMENTS						
Examiner Initials	Cite No.	Document Number		Publication Date MM-DD-YYYY	Name of Patentee or Applicant of Cited Document	Pages, Columns, Lines Where Relevant Passages or Figures Appear
		Number	Kind Code (if known)			
<i>es</i>	A19	5,864,653	--	01/26/99	Tavallaei et al.	
	A20	6,070,253	--	05/30/00	Tavallaei et al.	
	A21	5,884,027	--	03/16/99	Garbus et al.	
	A22	6,131,119	--	10/10/00	Fukui	
	A23	5,729,705	--	03/17/98	Weber	
	A24	5,751,975	--	05/12/98	Gillespie et al.	
	A25	5,680,556	--	10/21/97	Begun et al.	
	A26	5,581,714	--	12/03/96	Amini et al.	
	A27	5,774,683	--	06/30/98	Gulick	
	A28	6,330,629	B1	12/11/01	Kondo et al.	
	A29	5,845,107	--	12/01/98	Fisch et al.	
	A30	4,695,948	--	09/22/87	Blevins et al.	
	A31	5,598,541	--	01/28/97	Malladi	
	A32	5,163,131	--	11/10/92	Row et al.	
	A33	5,414,820	--	10/09/95	McFarland et al.	
	A34	5,857,080	--	01/05/99	Jander et al.	
	A35	5,941,969	--	08/24/99	Ram et al.	
	A36	6,223,266	B1	04/24/01	Sartore	
	A37	5,991,797	--	11/23/99	Futral et al.	
	A38	5,257,386	--	10/26/93	Saito	
	A39	5,701,491	--	12/23/97	Dunn et al.	
Examiner Signature				Date Considered	1-12-05	

INFORMATION DISCLOSURE STATEMENT BY APPLICANT				Application Number	10/658,163	
				Filing Date	September 9, 2003	
				First Named Inventor	Geoffrey B. Hoese, et al.	
				Group Art Unit	2186	
				Examiner Name	Unknown	
Sheet 1 of 1			Attorney Docket Number	CROSS1120-13		
U.S. PATENT DOCUMENTS						
Examiner Initials	Cite No.	Document Number		Publication Date MM-DD-YYYY	Name of Patentee or Applicant of Cited Document	
		Number	Kind Code (if known)			
<i>W</i>		US-5491812	--	02/13/1996	Pisello et al.	
		US-				
		US-				
		US-				
		US-				
		US-				
		US-				
		US-				
		US-				
		US-				
		US-				
		US-				
		US-				
		US-				
		US-				
		US-				
		US-				
		US-				
		US-				
Examiner Initials	Cite No.	FOREIGN PATENT DOCUMENTS			Publication Date MM-DD-YYYY (Number 43)	Name of Patentee or Applicant of Cited Document
		Country Code	Number	Kind Code (if known)		
<i>W</i>		GB	2296798	A	07/10/1996	Spring Consultants Limited
<i>W</i>		GB	2297636	A	08/07/1996	Spring Consultants Limited
Examiner Signature				Date Considered	<i>1-18-05</i>	

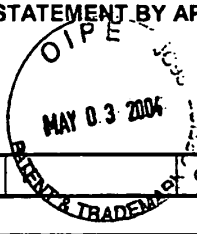
INFORMATION DISCLOSURE STATEMENT BY APPLICANT 		Applicat ⁿ Number	10/658,163		
		Filing Date	September 9, 2003		
		First Named Inventor	Geoffrey B. Hoese, et al.		
		Group Art Unit	2186		
		Examiner Name	Unknown		
Sheet	1	of	1	Attorney Docket Number	CROSS1120-13
NON-PATENT LITERATURE DOCUMENTS					
	C1	DIGITAL StorageWorks, Using Your HSZ70 Array Controller in a SCSI Controller Shelf (DS-BA356-M Series), <i>User's Guide</i> , pp. 1-1 through A-5 with index, January 1998.			
	C2	DIGITAL StorageWorks, HSZ70 Array Controller HSOF Version 7.0 (EK-HSZ70-CG.A01) <i>Configuration Manual</i> , pp. 1-2 through G15 with index, July 1997.			
	C3	DIGITAL StorageWorks, HSZ70 Array Controller HSOF Version 7.0, <i>CLI Reference Manual</i> , pp. 1-156, July 1997.			
Examiner Signature				Date Considered	1-18-05

INFORMATION DISCLOSURE STATEMENT BY APPLICANT			Application Number		10/658,163	
			Filing Date		September 9, 2003	
			First Named Inventor		Geoffrey B. Hoese, et al.	
			Group Art Unit		2186	
			Examiner Name		Unknown	
Sheet	of 1	Attorney Docket Number		CROSS1120-13		
U.S. PATENT DOCUMENTS						
Examiner Initials	Cite No.	Document Number		Publication Date MM-DD-YYYY	Name of Patentee or Applicant of Cited Document	
		Number	Kind Code (if known)			
ES		US-6219774	B1	04/17/2001	Kikuchi et al.	
		US-				
		US-				
		US-				
		US-				
		US-				
		US-				
		US-				
		US-				
		US-				
		US-				
		US-				
		US-				
		US-				
		US-				
		US-				
		US-				
Examiner Initials	Cite No.	FOREIGN PATENT DOCUMENTS			Publication Date MM-DD-YYYY (Number 43)	Name of Patentee or Applicant of Cited Document
		Country Code	Number	Kind Code (if known)		
Examiner Signature				Date Considered	1-18-05	

INFORMATION DISCLOSURE STATEMENT BY APPLICANT			Application Number	10/658,163			
			Filing Date	September 9, 2003			
			First Named Inventor	Geoffrey B. Hoese, et al.			
			Group Art Unit	2186			
			Examiner Name	Unknown			
Sheet 1 of 1			Attorney Docket Number	CROSS1120-13			
U.S. PATENT DOCUMENTS							
Examiner Initials	Cite No.	Document Number		Publication Date MM-DD-YYYY	Name of Patentee or Applicant of Cited Document	Pages, Columns, Lines Where Relevant Passages or Figures Appear	
		Number	Kind Code (if known)				
		US-6073209	--	06/06/00	Bergsten		
		US-6134617		10/17/00	Weber		
		US-6363462	B1	03/26/02	Bergsten		
		US-					
		US-					
		US-					
		US-					
		US-					
		US-					
		US-					
		US-					
		US-					
		US-					
		US-					
		US-					
		US-					
		US-					
		US-					
Examiner Initials	Cite No.	FOREIGN PATENT DOCUMENTS			Publication Date MM-DD-YYYY (Number 43)	Name of Patentee or Applicant of Cited Document	Pages, Columns, Lines Where Relevant Passages or Figures Appear
		Country Code	Number	Kind Code (if known)			
Examiner Signature					Date Considered	1-18-05	

Duplicate
had date
applied

Notice of References Cited	Application/Control No. 10/658,163	Applicant(s)/Patent Under Reexamination HOESE ET AL.	
	Examiner Christopher B Shin	Art Unit 2182	Page 1 of 1

U.S. PATENT DOCUMENTS

*	Document Number Country Code-Number-Kind Code	Date MM-YYYY	Name	Classification
A	US-6,421,753	07-2002	Hoese et al.	710/305
B	US-6,789,152	09-2004	Hoese et al.	710/305
C	US-6,763,419	07-2004	Hoese et al.	709/250
D	US-6,738,854	05-2004	Hoese et al.	710/305
E	US-6,425,035	07-2002	Hoese et al.	710/105
F	US-5,941,972	08-1999	Hoese et al.	710/315
G	US-6,185,203	02-2001	Berman, Stuart B.	370/351
H	US-5,978,379	11-1999	Chan et al.	370/403
I	US-6,000,020	12-1999	Chin et al.	711/162
J	US-			
K	US-			
L	US-			
M	US-			

FOREIGN PATENT DOCUMENTS

*	Document Number Country Code-Number-Kind Code	Date MM-YYYY	Country	Name	Classification
N					
O					
P					
Q					
R					
S					
T					

NON-PATENT DOCUMENTS

*	Include as applicable: Author, Title Date, Publisher, Edition or Volume, Pertinent Pages)
U	
V	
W	
X	

*A copy of this reference is not being furnished with this Office action. (See MPEP § 707.05(a).)
Dates in MM-YYYY format are publication dates. Classifications may be US or foreign.

Search Notes



Application No.

10/658,163

Examiner

Christopher B Shin

Applicant(s)

HOESE ET AL.

Art Unit

2182

SEARCHED

Class	Subclass	Date	Examiner
710	1-5 8-13 22-28		
	1-4-08		
	305-306		
	305,129		
7-9	280		

SEARCH NOTES
(INCLUDING SEARCH STRATEGY)

	DATE	EXMR
PLUS searched	1-15-05	☞
PALM searched for double patenting	1-13-08	☞
EAST (USPAT, epo, JPO, derwent, IBM TDB)	1-18-08	☞

INTERFERENCE SEARCHED

Class	Subclass	Date	Examiner

Index of Claims



Application No.

10/658,163

Examiner

Christopher B Shin

Applicant(s)

HOESE ET AL.

Art Unit

2182

√	Rejected
=	Allowed

-	(Through numeral) Cancelled
+	Restricted

N	Non-Elect d
I	Interference

A	Appeal
O	Objected

Claim		Date	
Final	Original		
	19/15		
	20		
	24		
	28		
	35		
	42		
	48		
	50		

Claim		Date	
Final	Original		
	51		
	52		
	53		
	54		
	55		
	56		
	57		
	58		
	59		
	60		
	61		
	62		
	63		
	64		
	65		
	66		
	67		
	68		
	69		
	70		
	71		
	72		
	73		
	74		
	75		
	76		
	77		
	78		
	79		
	80		
	81		
	82		
	83		
	84		
	85		
	86		
	87		
	88		
	89		
	90		
	91		
	92		
	93		
	94		
	95		
	96		
	97		
	98		
	99		
	100		

Claim		Date	
Final	Original		
	101		
	102		
	103		
	104		
	105		
	106		
	107		
	108		
	109		
	110		
	111		
	112		
	113		
	114		
	115		
	116		
	117		
	118		
	119		
	120		
	121		
	122		
	123		
	124		
	125		
	126		
	127		
	128		
	129		
	130		
	131		
	132		
	133		
	134		
	135		
	136		
	137		
	138		
	139		
	140		
	141		
	142		
	143		
	144		
	145		
	146		
	147		
	148		
	149		
	150		



UNITED STATES PATENT AND TRADEMARK OFFICE

UNITED STATES DEPARTMENT OF COMMERCE
United States Patent and Trademark Office
Address: COMMISSIONER FOR PATENTS
P.O. Box 1450
Alexandria, Virginia 22313-1450
www.uspto.gov

BIBDATASHEET

CONFIRMATION NO. 5675

Bib Data Sheet

Table with 5 columns: SERIAL NUMBER (10/658,163), FILING DATE (09/09/2003), CLASS (710), GROUP ART UNIT (2182), ATTORNEY DOCKET NO. (CROSS1120-13)

APPLICANTS

Geoffrey B. Hoese, Austin, TX;

Jeffry T. Russell, Cibolo, TX;

** CONTINUING DATA *****

This application is a CON of 10/081,110 02/22/2002 PAT 6,789,152
which is a CON of 09/354,682 07/15/1999 PAT 6,421,753
which is a CON of 09/001,799 12/31/1997 PAT 5,941,972

** FOREIGN APPLICATIONS *****

IF REQUIRED, FOREIGN FILING LICENSE GRANTED
** 12/11/2003

** SMALL ENTITY **

Table with 5 columns: Foreign Priority claimed, 35 USC 119 (a-d) conditions met, STATE OR COUNTRY (TX), SHEETS/DRAWING (2), TOTAL CLAIMS (39), INDEPENDENT CLAIMS (7)

ADDRESS

25094
DLA PIPER RUDNICK GRAY CARY US, LLP
2000 University Avenue
E. Palo Alto , CA
94303-2248

TITLE

Storage router and method for providing virtual local storage

Table with 2 columns: FILING FEE RECEIVED (779), FEES: Authority has been given in Paper... and a list of fee checkboxes (All Fees, 1.16 Fees, 1.17 Fees, 1.18 Fees, Other)

PLUS Search Results for S/N 10658163, Searched January 12, 2005

The Patent Linguistics Utility System (PLUS) is a USPTO automated search system for U.S. Patents from 1971 to the present. PLUS is a query-by-example search system which produces a list of patents that are most closely related linguistically to the application searched. This search was prepared by the staff of the Scientific and Technical Information Center, SIRA.

5941972	5991844	5263139	5950203
6041381	6101559	5283828	5948075
6421753	6148326	5289589	5964848
6425035	6154802	5313589	5987627
6425036	6247040	5357614	5996030
6446141	6249831	5394526	6029209
6738854	6321298	5454098	6029227
6763419	6493772	5493547	6044411
6772290	6534716	5497476	6065096
6772308	6557049	5515239	6078979
6772309	6591310	5546550	6092154
6789152	6608819	5555390	6105092
6118776	6697875	5560016	6122723
6151331	6757694	5564024	6141712
6185203	6763409	5572659	6157962
6199112	6766412	5611057	6161104
6470007	6807581	5615335	6185580
6529963	6826714	5625840	6185621
6650656	6834326	5625847	6192433
6704809	5805920	5628014	6199194
6061360	6816917	5634111	6216202
6061360	6772270	5642337	6216202
5931947	5283872	5649233	6233692
5935205	5361346	5651139	6272533
6148352	5495607	5659801	6286057
6219753	5991813	5664145	6292876
6219771	6247099	5671439	6304942
6219753	5678042	5680579	6311217
6219771	5337414	5691966	6378084
6243829	5396596	5696968	6385706
6338110	5687390	5732224	6393158
6400730	5737634	5737524	6397308
6401170	5790775	5740386	6408343
6526489	5829053	5748909	6442604
6643748	5860079	5754821	6449652
6742034	5864568	5758101	6460099
6785742	5938744	5765023	6487638
6832289	6021454	5787304	6499075
6718402	6105763	5805921	6507893
6209023	6115772	5809279	6529996
6057863	6188571	5813016	6538669
5812754	6199122	5829048	6549934
5991891	6199130	5875349	6615284
6000020	6343352	5917998	6631442
6065087	6654851	5920700	6658587
6202115	4851998	5930817	6671820
6792479	H000696	5928327	6754785
5610745	5206943	5933834	6757767
5848251	5210855	5935260	6769021
5898828	5241508	5938747	6775702

10658163_CLS
Most Frequently Occurring Classifications of Patents Returned
From A Search of 10658163 on January 12, 2005

Original Classifications

10	711/114
7	710/1
7	710/5
7	711/112
5	710/305
5	710/312
4	709/226
4	710/302
4	710/8
4	711/163
4	711/164
4	714/6
3	370/351
3	707/10
3	710/100
3	710/104
3	710/19
3	710/315
3	711/162
2	370/455
2	707/205
2	709/219
2	709/250
2	710/15
2	710/2
2	710/301
2	710/306
2	710/316
2	710/62
2	710/74
2	711/133
2	711/153
2	714/4
2	714/42

Cross-Reference Classifications

15	711/114
10	711/112
8	710/5
8	714/6
7	710/33
7	711/170
7	711/173

10658163_CLS

6 707/204
6 710/36
6 710/74
6 711/100
6 711/113
6 711/162
5 709/230
5 710/2
5 713/1
4 707/8
4 710/10
4 710/100
4 710/104
4 710/21
4 710/72
4 710/8
4 711/202
4 711/4
3 370/401
3 709/203
3 709/214
3 709/217
3 709/227
3 709/250
3 710/105
3 710/106
3 710/107
3 710/11
3 710/52
3 710/9
3 711/118
3 711/154
3 711/156
3 711/161
3 711/165
3 711/209
3 714/7
2 361/724
2 361/727
2 370/360
2 370/402
2 370/404
2 370/422
2 370/461
2 707/10
2 709/200
2 709/213
2 709/216

Page 2

10658163_CLS

2 709/219
2 709/222
2 709/238
2 709/249
2 710/110
2 710/15
2 710/18
2 710/22
2 710/241
2 710/302
2 710/305
2 710/310
2 710/312
2 710/313
2 710/32
2 710/38
2 710/62
2 711/111
2 711/117
2 711/141
2 711/145
2 713/200
2 713/202
2 713/340
2 714/22
2 714/25
2 714/5
2 714/800
2 718/100
2 719/326
2 725/92
2 725/93
2 725/97

Combined Classifications

25 711/114
17 711/112
15 710/5
12 714/6
9 711/162
8 710/74
8 710/8
7 710/1
7 710/100
7 710/104
7 710/2
7 710/305
7 710/312

10658163_CLS

7 710/33
7 710/36
7 711/113
7 711/170
7 711/173
6 707/204
6 709/230
6 710/302
6 711/100
5 707/10
5 709/226
5 709/250
5 710/10
5 711/163
5 711/164
5 711/202
5 713/1
4 707/8
4 709/203
4 709/219
4 709/227
4 710/105
4 710/107
4 710/15
4 710/19
4 710/21
4 710/315
4 710/52
4 710/62
4 710/72
4 710/9
4 711/118
4 711/4
4 714/7
3 361/727
3 370/351
3 370/401
3 709/213
3 709/214
3 709/216
3 709/217
3 710/106
3 710/11
3 710/22
3 710/313
3 710/316
3 711/111
3 711/117

Page 4

10658163_CLS

3 711/133
3 711/141
3 711/154
3 711/156
3 711/161
3 711/165
3 711/209
3 714/25
3 714/4
3 714/42
3 714/5
2 361/685
2 361/724
2 370/360
2 370/402
2 370/404
2 370/422
2 370/455
2 370/461
2 703/24
2 707/205
2 709/200
2 709/211
2 709/222
2 709/231
2 709/238
2 709/245
2 709/249
2 710/110
2 710/18
2 710/240
2 710/241
2 710/27
2 710/3
2 710/301
2 710/306
2 710/310
2 710/314
2 710/32
2 710/38
2 710/60
2 710/68
2 711/137
2 711/145
2 711/147
2 711/152
2 711/153
2 713/100

10658163_CLS

2 713/2
2 713/200
2 713/201
2 713/202
2 713/340
2 714/22
2 714/47
2 714/48
2 714/800
2 718/100
2 718/103
2 718/108
2 719/326
2 725/92
2 725/93
2 725/97

EAST - [.wsp:1]

File View Edit Tools Window Help

Search Lib Browse Queue Clear

DBs: USPAT, EPD, JPO, DERWENT, IBM, TDB Plurals

Default operator: OR Highlight all hit terms initially

fabric with map\$4

S1: (8) ("6789152") or ("6421753") or ("5941972") or ("6219771") or ("5491812") or ("5941972") or ("5941972") or ("6041381") or ("6421753") or ("6425035") or ("6425036") or ("5991844") or ("6101559") or ("6148326") or ("6154802") or ("6247040") or ("5263139") or ("5283828") or ("5289589") or ("5313589") or ("5357614") or (196) S2 S3 S4

S6: (19691) (fiber fibre) near5 channel\$3

S7: (97) S5 and S6

S8: (717) network near9 server near9 map\$4

S9: (19691) (fiber fibre) near5 channel\$3

S10: (22676) S8 with S9

S11: (0) S8 with S9

S12: (139) (disk stor\$4 medium) with S8

S13: (136) S9 with map\$4

S14: (59) lun near9 virtual

S15: (14710) storage near9 map\$4

S16: (19) S9 with S15

S18: (1) S9 with S17

S17: (409) fabric with map\$4

Favorites

Tagged (3)

UDC

Queue

Trash

BRS form IS&R form Image Text HTML

	U	Document ID	Issue Date	Pages	Title	Current OR	Current XRef	Retrieval Class
1	<input type="checkbox"/>	US 6842840 B1	20050111	16	Controller which determines presence of memory in a node of a data	711/172	365/185.05; 365/236;	Reohr, Jr.;
2	<input checked="" type="checkbox"/>	US 6834324 B1	20041221	13	System and method for virtual tape volumes	711/111	710/305; 711/203;	Wood; Ro
3	<input checked="" type="checkbox"/>	US 6834311 B2	20041221	22	Method, system, and program for enabling communication between	709/245	370/352; 370/355;	Rao; Rag
4	<input checked="" type="checkbox"/>	US 6834139 B1	20041221		Link discovery and verification procedure using loopback	385/24	370/216; 370/222;	Prairie; Da
5	<input checked="" type="checkbox"/>	US 6831916 B1	20041214		Host-fabric adapter and method of connecting a host system to a	370/359	370/389; 370/429;	Parthasar
6	<input checked="" type="checkbox"/>	US 6829405 B1	20041207		Reconfigurable optical add-drop multiplexer	385/24	385/17	Wachsmo
7	<input checked="" type="checkbox"/>	US 6829254 B1	20041207		Method and apparatus for providing efficient application-level switching	370/535	370/466	Rajahalme
8	<input checked="" type="checkbox"/>	US 6821385 B2	20041123		Method of manufacture of tissue	162/109	162/116;	Burazin; M

Hits Details HTML

NUM



UNITED STATES PATENT AND TRADEMARK OFFICE

COMMISSIONER FOR PATENTS
UNITED STATES PATENT AND TRADEMARK OFFICE
P.O. BOX 1450
ALEXANDRIA, VA 22313-1450
www.uspto.gov

MAIL

John L. Adair
GRAY, CARY, WARE & FREIDENRICH LLP
2000 University Avenue
E. Palo Alto CA 94303-2248

NOV 26 2004

DIRECTOR OFFICE
TECHNOLOGY CENTER 2100

In re Application of:
Goeffrey B. HOESE et al.
Application No. 10/658,163
Filed: September 9, 2003
For: STORAGE ROUTER AND METHOD FOR
PROVIDING VIRTUAL LOCAL
STORAGE

DECISION ON PETITION TO
MAKE SPECIAL UNDER
M.P.E.P. §708.02(II):
INFRINGEMENT

This is a decision on the petition, filed November 21, 2003, under 37 C.F.R. § 1.102(d) and M.P.E.P. §708.02(II): Infringement, to make the above-identified application special.

The petition is **GRANTED**.

A grantable petition under 37 C.F.R. § 1.102(d), and M.P.E.P. § 708.02, Section II, must be accompanied by payment of the fee under 37 C.F.R. § 1.17(h) and a statement under 37 C.F.R. § 1.102 by the applicant or assignee or statements by an attorney/agent registered to practice before the Patent and Trademark Office that (A) there is an infringing device or product actually on the market or method in use; (B) a *rigid comparison* of the alleged infringing device, product, or method with the claims of the application has been made, and that, in his or her opinion, some of the claims are **unquestionably infringed**; and (C) he or she has made or caused to be made a careful and thorough search of the prior art or has a good knowledge of the prior art. Applicant must provide one copy of each of the *references deemed most closely related* to the subject matter encompassed by the claims.

Applicant's submission meets all the criteria set out above. Accordingly, the Petition is **GRANTED**.

The application file is being forwarded to the Examiner of Record for expedited examination.

Vincent N. Trans
Special Program Examiner
Technology Center 2100
Computer Architecture, Software, and
Information Security
571-272-3613

RECEIVED
CENTRAL FAX CENTER

IN THE UNITED STATES PATENT AND TRADEMARK OFFICE		MAY 18 2004
Supplement to Petition to Make Special Filed 11/21/03		Atty. Docket No. CROSS1120-13
OFFICIAL		
Applicants: Goeffrey B. Hoese, et al.		
Application Number 10/658,163	Filed September 9, 2003	
For: Storage Router and Method for Providing Virtual Local Storage		
Group Art Unit	Confirmation Number:	

Via Facsimile 703-872-9306
Mail Stop: Patent Application
 Commissioner for Patents
 P.O. Box 1450
 Alexandria, VA 22313

Certification Under 37 C.F.R. §1.18

I hereby certify that this correspondence is being facsimile transmitted to the United States Patent and Trademark Office on May 18, 2004.

Carolyn J. Williams
 Carolyn J. Williams

Dear Sir:

On May 18, 2004, Geoffrey Gaffin of the United States Patent Trademark Office informed applicants that the Petition to Make Special Because of Actual Infringement Pursuant to 37 C.F.R. 1.102 and MPEP 708.02(II) (the "Petition") filed in the above referenced application on November 21, 2003 did not include a referenced Declaration of Robert Griswold in Support of the Petition to Make Special Because of Actual Infringement (the "Declaration"). According to Applicants' files, the Declaration was included with the Petition. For convenience, Applicants are hereby enclosing a copy of the Declaration

Respectfully submitted,

Gray Cary Ware & Freidenrich LLP

John L. Adair
 John L. Adair
 Reg. No. 48,828

Dated: May 18, 2004

1221 South MoPac Expressway
 Suite 400
 Austin, TX 78746-6875
 Tel. (512) 457-7142
 Fax. (512) 457-7001

BEST AVAILABLE COPY

Gray Cary\AU\4128082.1
 103671-990004

RECEIVED
CENTRAL FAX CENTER

MAY 18 2004

OFFICIAL

GRAYCARY

1221 S. MoPac Expressway, Suite 400
Austin, TX 78746-6875
www.graycary.com
O] 512-457-7142
F] 512-457-7001

May 18, 2004

FAX TRANSMISSION COVER SHEET

To: **Commissioner for Patents**

Telephone:

Fax Number:

703-872-9306

From: **John L. Adair**
512-457-7142

Client-Matter Number:

103671.990004
CROSS1120-13

Re: **Supplement to Petition to Make Special Filed 11/21/03**

Pages: - 4 - (including this form)

Originals: will be mailed will not be mailed

If there is a problem with this transmission, please call **Katherin Cope (512) 457-7024**
Fax Operator/Ext.

Message:

BEST AVAILABLE COPY

AUSTIN LA JOLLA SACRAMENTO SAN DIEGO SAN FRANCISCO SEATTLE SILICON VALLEY WASHINGTON, DC

PAGE 1/4 * RCVD AT 5/18/2004 6:38:43 PM [Eastern Daylight Time] * SVR:USPTO-EFAX-1/0 * DNIS:8729306 * CSID:512 457 7070 * DURATION (mm-ss):01-10

COPY

IN THE UNITED STATES PATENT AND TRADEMARK OFFICE	
DECLARATION BY ROBERT GRISWOLD IN SUPPORT OF PETITION TO MAKE SPECIAL BECAUSE OF ACTUAL INFRINGEMENT	Atty. Docket No. (Opt.) CROSS1120-13
Applicant Geoffrey B. Hoese, et al.	
Application Number 10/658,163	Filed September 9, 2003
For Storage Router and Method for Providing Virtual Local Storage	
Group Art Unit Unknown	Examiner Unknown
Confirmation Number: Unknown	

**VIA FACSIMILE (703) 306-5404 and
Express Mail**

Commissioner for Patents
P.O. Box 1450
Alexandria, VA 22313-1450

Dear Sir:

Certificate of Mailing Under 37 C.F.R. 1.10

I hereby certify that this correspondence is being deposited with the United States Postal Service as Express Mail No. EV351127304US in an envelope addressed to: Commissioner for Patents, P.O. Box 1450, Alexandria, VA 22313-1450 on November 21, 2003.

Katherin Cope

I, Robert Griswold, Vice President of Technology and Information and Chief Technologist of Crossroads Systems, Inc. (assignee of the above-referenced application) do hereby make the following declarations:

1. The present application (United States Application Number 10/658,163) is an application filed September 9, 2001 as a continuation of U.S. Application Number 10/081,110, which in turn is a continuation of U.S. Application No. 09/354,682, now U.S. Patent No. 6,421,753, which in turn is a continuation of U.S. Application No. 09/001,799, now U.S. Patent No. 5,941,972.
2. The present application includes, among others, claims to a storage router for providing virtual local storage on remote storage devices across two fibre channel transport media.
3. I have become aware that an infringing device is currently on the market.

Gray CaryAUM117814.1
103671-990004

BEST AVAILABLE COPY.

Attorney Docket No.
CROSS1120-13

10/658,163
Customer ID: 25094

2

4. I have made a rigid comparison of the infringing device with the storage router claims of the present application and it is my opinion that at least one of the claims is unquestionably infringed.

5. I have a good knowledge of the pertinent art.

Respectfully submitted,

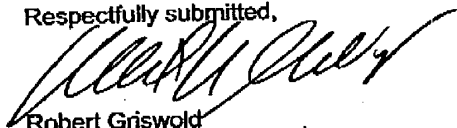

Robert Griswold
Vice President of Technology and Information
Chief Technologist
Crossroads Systems, Inc.

Date: November 21, 2003.

BEST AVAILABLE COPY

Gray CaryAU4117814.1
103671-990004

IN THE UNITED STATES PATENT AND TRADEMARK OFFICE	
INFORMATION DISCLOSURE STATEMENT BY APPLICANT	Atty. Docket No. (Opt.) CROSS1120-13



Applicants Geoffrey B. Hoese, et al.	
Application Number 10/658,163	Filed September 9, 2003
For STORAGE ROUTER AND METHOD FOR PROVIDING VIRTUAL LOCAL STORAGE	
Group Art Unit 2186	Examiner Unknown

Commissioner for Patents
P.O. Box 1450
Alexandria, VA 22313-1450

<u>Certificate of Mailing</u>
I hereby certify that this correspondence is being deposited with the U.S. Postal Service as First Class Mail in an envelope addressed to: Commissioner for Patents, P.O. Box 1450, Alexandria, VA 22313-1450 on <u>APRIL 29,</u> 2004.
 _____ Laura M. McGuire

Applicants respectfully request, pursuant to 37 C.F.R. §§ 1.56, 1.97 and 1.98, that the art listed on the attached SB08A form be considered and cited in the examination of the above-identified application. A copy of the art is enclosed for the convenience of the Examiner. Furthermore, pursuant to 37 C.F.R. §§ 1.97(g) and (h), no representation is made that a search has been made or that this art is material to patentability of the present application.

Applicants respectfully submit that the claims of Applicants' above-referenced patent application are patentably distinguishable from these references.

Respectfully submitted,

Gray Cary Ware & Freidenrich LLP
Attorneys for Applicant

John L. Adair
Reg. No. 48,828

Dated: 4/20/04
1221 S. MoPac Expressway, Suite 400
Austin, Texas 78746
Tel. (512) 457-7142
Fax. (512) 457-7001

AJM126769.1
103671-990004

INFORMATION DISCLOSURE STATEMENT BY APPLICANT		Application Number		10/658,163		
		Filing Date		September 9, 2003		
		First Named Inventor		Geoffrey B. Hoese, et al.		
		Group Art Unit		2186		
		Examiner Name		Unknown		
Sheet	of	1	Attorney Docket Number		CROSS1120-13	
U.S. PATENT DOCUMENTS						
Examiner Initials	Cite No.	Document Number		Publication Date MM-DD-YYYY	Name of Patentee or Applicant of Cited Document	
		Number	Kind Code (if known)			
		US-6219771	B1	04/17/2001	Kikuchi et al.	
		US-				
		US-				
		US-				
		US-				
		US-				
		US-				
		US-				
		US-				
		US-				
		US-				
		US-				
		US-				
		US-				
		US-				
		US-				
		US-				
		US-				
		US-				
Examiner Initials	Cite No.	FOREIGN PATENT DOCUMENTS			Publication Date MM-DD-YYYY (Number 43)	Name of Patentee or Applicant of Cited Document
		Country Code	Number	Kind Code (if known)		
Examiner Signature					Date Considered	

IN THE UNITED STATES PATENT AND TRADEMARK OFFICE	
INFORMATION DISCLOSURE STATEMENT BY APPLICANT	Atty. Docket No. (Opt.) CROSS1120-13



Applicants Geoffrey B. Hoese, et al.	
Application Number 10/658,163	Filed September 9, 2003
For STORAGE ROUTER AND METHOD FOR PROVIDING VIRTUAL LOCAL STORAGE	
Group Art Unit 2186	Examiner Unknown

Commissioner for Patents
P.O. Box 1450
Alexandria, VA 22313-1450

<u>Certificate of Mailing</u>
I hereby certify that this correspondence is being deposited with the U.S. Postal Service as First Class Mail in an envelope addressed to: Commissioner for Patents, P.O. Box 1450, Alexandria, VA 22313-1450 on <u>APRIL 9</u> 2004.
 Laura M. McGuire

Applicants respectfully request, pursuant to 37 C.F.R. §§ 1.56, 1.97 and 1.98, that the art listed on the attached SB08A and SB08B forms be considered and cited in the examination of the above-identified application. A copy of the art is enclosed for the convenience of the Examiner. Furthermore, pursuant to 37 C.F.R. §§ 1.97(g) and (h), no representation is made that a search has been made or that this art is material to patentability of the present application.

Applicants respectfully submit that the claims of Applicants' above-referenced patent application are patentably distinguishable from these references.

Respectfully submitted,

Gray Cary Ware & Freidenrich LLP
Attorneys for Applicant

John L. Adair
Reg. No. 48,828

Dated: April 5, 04
1221 S. McPac Expressway, Suite 400
Austin, Texas 78746
Tel. (512) 457-7142
Fax. (512) 457-7001

AU4125641.2
103671-990004

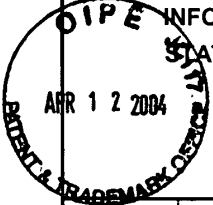
INFORMATION DISCLOSURE STATEMENT BY APPLICANT				Application Number	10/658,163	
				Filing Date	September 9, 2003	
				First Named Inventor	Geoffrey B. Hoese, et al.	
				Group Art Unit	2186	
				Examiner Name	Unknown	
Sheet	1	of	1	Attorney Docket Number	CROSS1120-13	
U.S. PATENT DOCUMENTS						
Examiner Initials	Cite No.	Document Number		Publication Date MM-DD-YYYY	Name of Patentee or Applicant of Cited Document	
		Number	Kind Code (if known)			
		US-5491812	--	02/13/1996	Pisello et al.	
		US-				
		US-				
		US-				
		US-				
		US-				
		US-				
		US-				
		US-				
		US-				
		US-				
		US-				
		US-				
		US-				
		US-				
		US-				
		US-				
		US-				
		US-				
		US-				
		US-				
Examiner Initials	Cite No.	FOREIGN PATENT DOCUMENTS			Publication Date MM-DD-YYYY (Number 43)	Name of Patentee or Applicant of Cited Document
		Country Code	Number	Kind Code (if known)		
		GB	2296798	A	07/10/1996	Spring Consultants Limited
		GB	2297636	A	08/07/1996	Spring Consultants Limited
Examiner Signature					Date Considered	

INFORMATION DISCLOSURE STATEMENT BY APPLICANT		Application Number		10/658,163	
		Filing Date		September 9, 2003	
		First Named Inventor		Geoffrey B. Hoese, et al.	
		Group Art Unit		2186	
		Examiner Name		Unknown	
		Attorney Docket Number		CROSS1120-13	
1	of	1			
NON-PATENT LITERATURE DOCUMENTS					
	C4	CRD-5500, SCSI RAID CONTROLLER Users Manual, Rev. 1.3, November 21, 1996, pp. 1-92.			
	C5	Black Box, SCSI Fiberoptic Extender, Single-Ended, Product Insert, 2 pages, 1996.			
	C6	CRD-5500, SCSI RAID CONTROLLER OEM Manual, Rev. 1.3, February 26, 1996, pp. 1-54.			
	C7	CRD-5500, RAID DISK ARRAY CONTROLLER Product Insert, pp. 1-5.			
	C8	IBM Technical publication: Guide to Sharing and Partitioning IBM Tape Library Dataservers, November 1996, pp. 1-256.			
	C9	IBM Technical publication: Magstar and IBM 3590 High Performance Tape Subsystem Technical Guide, November 1996, pp. 1-269.			
Examiner Signature				Date Considered	

This Page Is Inserted by IFW Operations
and is not a part of the Official Record

BEST AVAILABLE IMAGES

Defective images within this document are accurate representations of the original documents submitted by the applicant.

Defects in the images may include (but are not limited to):

- ⦿ BLACK BORDERS
 - TEXT CUT OFF AT TOP, BOTTOM OR SIDES
 - FADED TEXT
 - ILLEGIBLE TEXT
 - SKEWED/SLANTED IMAGES
 - COLORED PHOTOS
- ⦿ BLACK OR VERY BLACK AND WHITE DARK PHOTOS
 - GRAY SCALE DOCUMENTS

IMAGES ARE BEST AVAILABLE COPY.

**As rescanning documents *will not* correct images,
please do not report the images to the
Image Problem Mailbox.**

(12) UK Patent Application (19) GB (11) 2 296 798 (13) A

(43) Date of A Publication 10.07.1996

(21) Application No 9500173.1

(22) Date of Filing 05.01.1995

(71) Applicant(s)
Spring Consultants Limited

(Incorporated in the United Kingdom)

Unit 5, Ashbrook Mews, Westbrook Street,
BLEWBURY, Oxon, OX11 9QA, United Kingdom

(72) Inventor(s)
Andrew Paul George Randall
Norman Hamilton Burkies

(74) Agent and/or Address for Service
Atkinson & Co
Sixth Floor, High Holborn House, 52-54 High Holborn,
LONDON, WC1V 6SE, United Kingdom

(51) INT CL⁶
G06F 12/02

(52) UK CL (Edition O)
G4A AMX

(56) Documents Cited
None

(58) Field of Search
UK CL (Edition N) G4A AMX
INT CL⁶ G06F 12/02
ONLINE DATABASES : WPI, INSPEC

(54) Storing data efficiently on a RAID

(57) Data is stored in such a way that a plurality of user terminals 16 are given access to a large storage volume in the form of a redundant array of inexpensive drives (RAID 5) 21 to 25. The large storage volume is divided into a plurality of storage blocks and each of said blocks has a capacity which is smaller than the size of an emulated logical disc drive. In operation, physical blocks of data are mapped onto an emulated drive as storage is required up to a predetermined capacity.

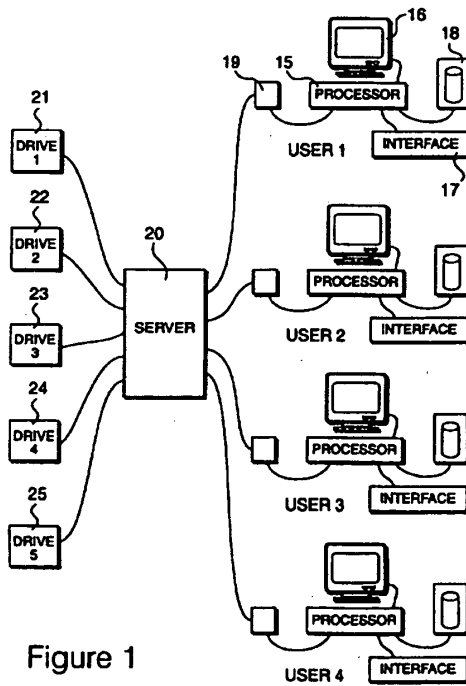

Figure 1

GB 2 296 798 A

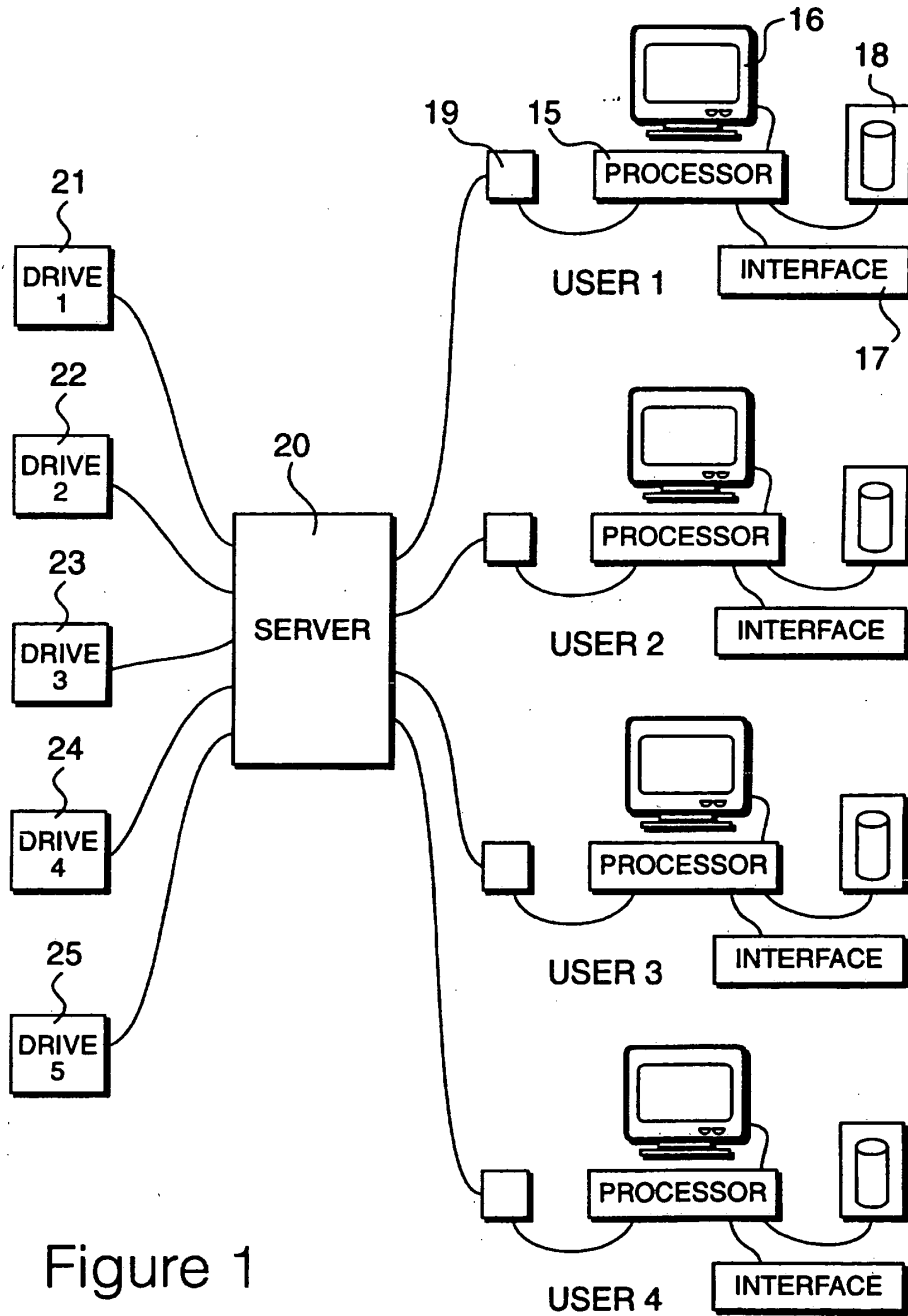

Figure 1

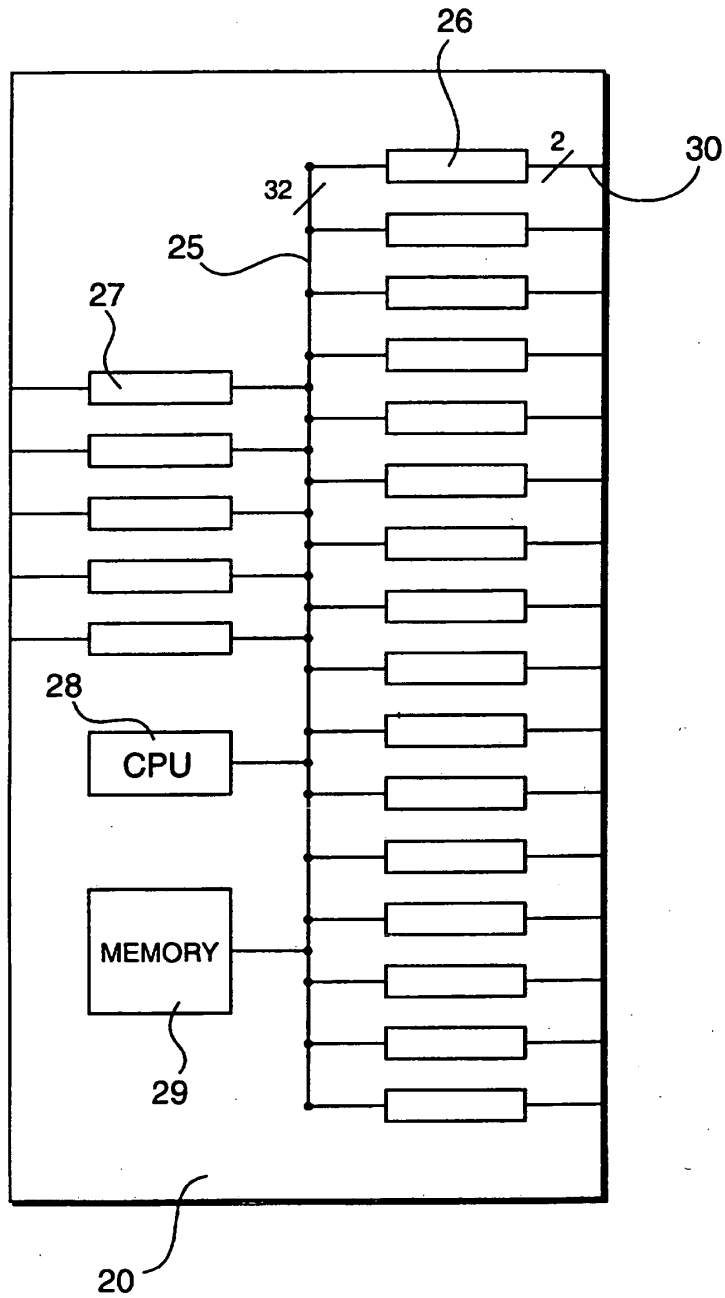

Figure 2

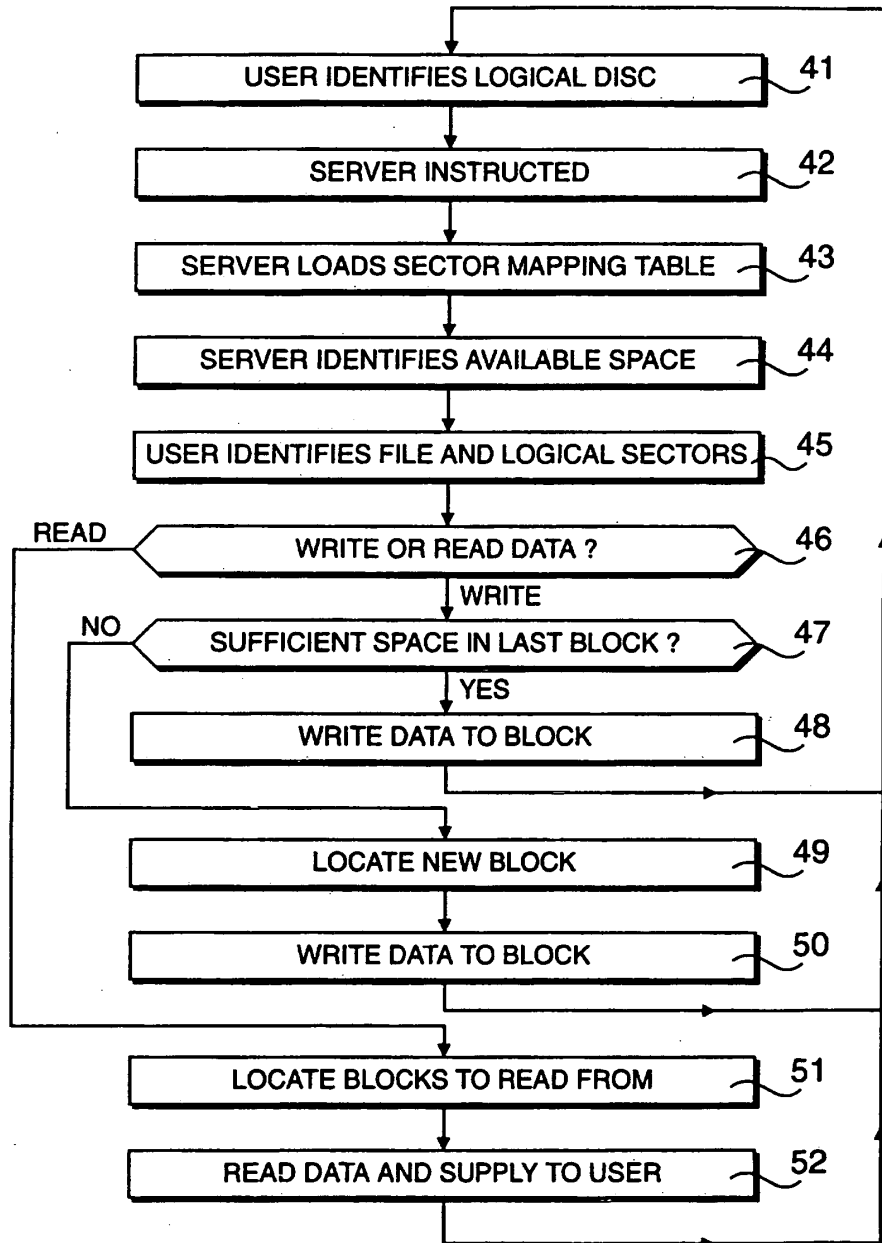

Figure 3

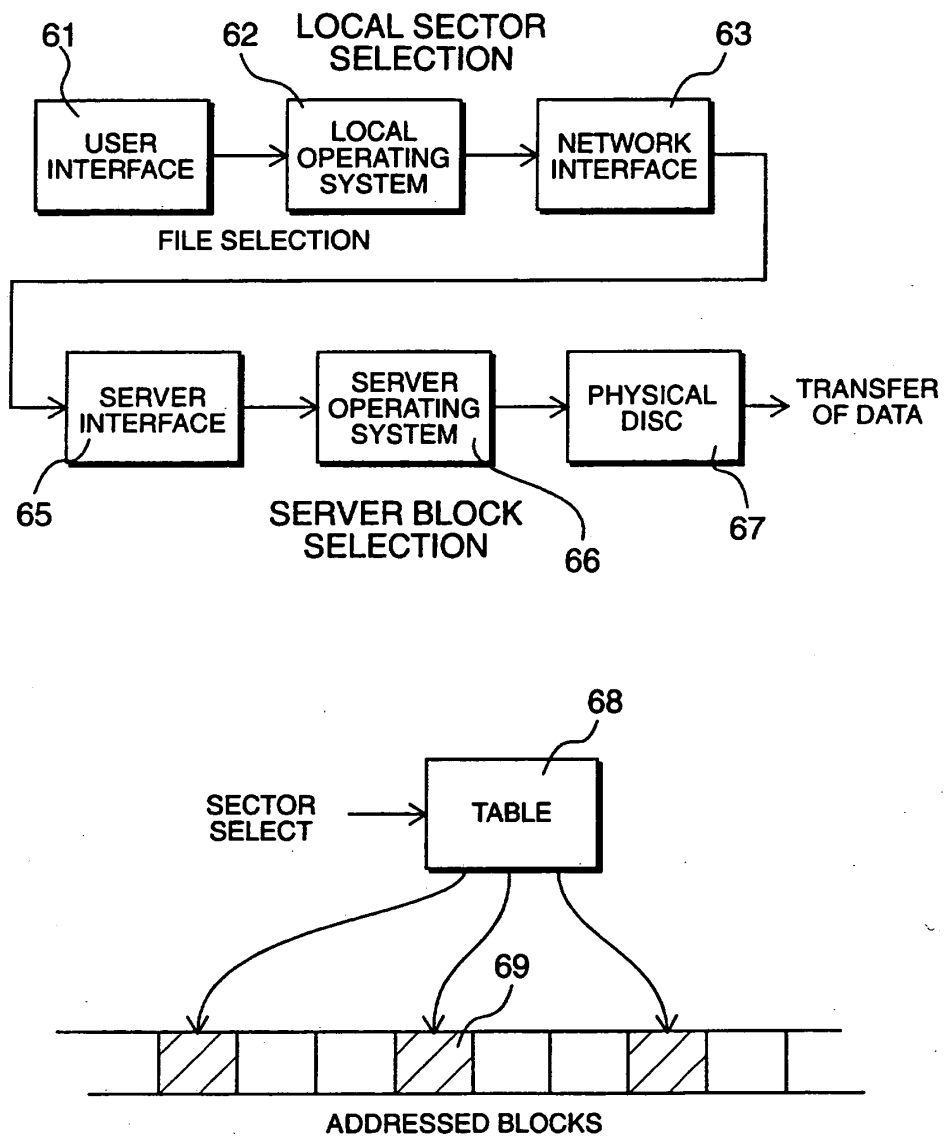

Figure 4

STORING DATA

The present invention relates to storing data. In particular, the present invention relates to an environment in which a plurality of user terminals
5 have shared access to a large storage volume.

Systems are known in which data storing devices, often referred to as volumes, are shared amongst a plurality of user terminals or workstations. Typically, the volume is associated with a local workstation, referred to as a server, and the totality of the workstations are interconnected by a network,
10 such as an ethernet. Such an arrangement provides efficient shared access to files provided that the amount of data contained within each file is small compared to the transmission bandwidth provided by the network. In operation, given that many users may be sharing the network bandwidth, the bandwidth allocated to any one particular user will be significantly less than
15 the theoretical maximum provided by the network. Thus, as files get larger, it is preferable for the workstations to be given direct access to a storage volume such that operational time is not lost while waiting for data to be transferred. For example, an A4 full colour image may consist of a total of 30 Mbytes of data. When transmitted over typical networks, a transfer
20 duration of several minutes may take place before the totality of the data has been received.

A problem with providing direct access to discs is that only one workstation may be given access to the data and in order for the data to be loaded into another machine, it may be necessary to physically move
25 transferrable discs, such as SCSI optical discs. Systems also exist under which a plurality of users may share direct access to a data storage device

and, consequently, measures must be implemented to remove the risk of contention problems. Thus, a particular workstation must release access to a particular file or disc partition before any of the other workstations may be allowed to write to that file.

5 In known systems, system specific software must be loaded into each workstation, so that each workstation is provided with instructions relating to the contention protocols. In addition, a plurality of workstations are given access to the shared volume by effectively dividing the volume into a plurality of partitions. Thus, in this way, a first workstation may write and
10 read data to a first partition of the disc, with a second workstation writing and reading to a second partition of the disc. At a later date, the first workstation may release the first partition, thereby allowing another workstation to be given access to this partition. In this way, a plurality of workstations may each access partitions within the volume without the data needing to be
15 transferred, thereby significantly improving operational performance.

 A problem with the above arrangement is that the partitioning of the disc may result in substantial storage regions being taken up that are only available for one workstation at any one time but do not actually contain valid data. Thus, for example, ten partitions of a very large disc volume may each
20 contain a relatively small amount of data. However, although a substantial amount of empty space remains on the disc, as far as the system is concerned, it would not be possible for this space to be allocated to another workstation, given that, as far as the system is concerned, the storage volume is fully allocated.

25 According to a first aspect of the present invention, there is provided a method of storing data wherein a plurality of user terminals access a large

storage volume, comprising steps of emulating the presence of a logical disc drive having a predetermined capacity; dividing said storage volume into a plurality of storage regions, wherein each of said regions is smaller than the size of an emulated logical disc drive; and mapping physical regions of data to an emulated drive dynamically as additional storage is required, up to said predetermined capacity.

Thus, in accordance with said first aspect, a workstation may be given access to a logical disc drive which it perceives as having a predetermined capacity. For example, the predetermined capacity may be similar to that provided by an optical disc providing 600 Mbytes of storage. However, physical storage locations on the large storage volume are only allocated, region by region, as the workstation demands additional storage through the writing of larger files to the disc.

In a preferred embodiment, a look-up table is associated with each accessible logical drive and a particular look-up table is loaded when its associated logical drive is selected.

According to a second aspect of the present invention, there is provided apparatus for storing data, having a plurality of user terminals and means for each of said terminals to be given access to said stored data, comprising means for emulating the presence of a logical disc drive having a predetermined capacity; means for dividing a storage volume into a plurality of storage regions, wherein each of said regions is smaller than the size of an emulated logical disc drive; and mapping means for mapping said physical regions of data to an emulated drive dynamically as additional storage is required, up to said predetermined capacity.

The system will now be described by way of example only, with reference to the accompanying Figures, in which:

Figure 1 shows an environment in which a plurality of workstations have access to a shared storage volume including a shared file server;

5 Figure 2 details the shared file server identified in Figure 1;

Figure 3 illustrates an application of the system shown in Figure 1; and

Figure 4 shows a schematic representation of the system, including the dynamic allocation of storage regions.

10 An environment in which a plurality of users have access to a shared storage volume is illustrated in Figure 1. In the environment shown in Figure 1, each workstation is provided with a processor 15, a visual display unit 16, an interface device in the form of a keyboard and/or a mouse or trackerball etc. 17 and a local disc drive storage device 18.

15 Each processor 15 is connected to a server interface 19 which allows said processors 15 to communicate with a shared file server 20. The file server 20 is connected to typically five physical hard disc drives 21, 22, 23, 24 and 25. This disc drive combination provides typically thirty-six Gbytes of storage with an access speed of typically 10 Mbytes per second.

20 Disc drives 21 to 25 may be configured as a redundant array, commonly referred to as a redundant array of inexpensive discs (RAID). In the preferred implementation, five discs are provided and the coding used to write data to the disc is commonly referred to as RAID 5. Thus, under this

protocol, redundant data is written to the discs such that if one of the drives becomes inoperable or suffers irretrievable damage, all of the data can be reconstituted from the remaining four drives.

5 Data is written to the drives in the form of identifiable blocks or regions of a predetermined length. The size of these blocks is determined from a trade-off between disc space optimisation and disc fragmentation. However, the system is primarily designed for storing large graphics files, therefore blocks may be quite large and it is proposed that said blocks should have a size between two Mbytes and thirty-two Mbytes. Similarly, it is
10 possible that the block size could be configurable for a particular application.

In operation, a user issues commands under software control which effectively result in a logical drive being made available by the server 20. Communication between the user and the server 20 is effected via the interface 19 and as far as the user is concerned, interface 19 presents a
15 standard small computer serial interface (SCSI) to the processor 15. Once a logical disc has been established, the user may access this drive.

The user's workstation receives data to the effect that it has been given access to a disc of a predetermined size, say 600 Mbytes for example, but in actuality, physical space is only allocated dynamically in regions as storage
20 space for the storage of actual data is required.

Thus, in the system shown in Figure 1 the server does not immediately allocate 600 Mbytes of storage to a user when access to a 600 Mbyte logical drive is requested. Space on drives 21 through 25 is not divided into 600 Mbytes (or similar) partitions. Drives 21 through 25 are divided into blocks

of between two and thirty-two Mbytes and blocks are only written to as data becomes available.

For the benefit of this illustration, it will be assumed that storage space on drives 21 through 25 has been divided into blocks of two Mbytes, thereby making two Mbyte blocks available for data storage purposes. As data is written to the drives, via an interface 19, said data will occupy one of said two Mbyte blocks. As the volume of data increases beyond two Mbytes, the server 20 will identify a new block of two Mbytes and data originating from a user will then continue to be written to this new two Mbyte block. Thus, for example, if a user has written a total of five Mbytes, the server is required to maintain a list of where these five Mbytes actually reside on the drives, in terms of three two-Mbyte blocks. However, as far as the user is concerned, five Mbytes of data have been written to on a logical drive having 600 Mbytes of available capacity.

Data is conventionally written to disc drives in terms of identifiable blocks. As far as the user is concerned, data is written to as blocks on a 600 Mbyte logical drive, which are in turn mapped onto real blocks on the RAID. However, the logical blocks may be written to in a substantially similar way to that in which real drives would be re-written to. Thus, it is not necessary for data to be written to the logical drives in what appears to be a contiguous region of disc space. Although the actual storage allocated for a logical drive is distributed over the RAID, the logical drives may appear, from the user's point of view, to be fragmented themselves. Thus, logical blocks of data may appear displaced over a logical drive, effectively emulating the presence of fragmentation on the logical disc. The system emulates such a situation by providing mapping firstly of blocks to logical drive locations and then mapping from logical drive locations to block locations on the RAID.

Many users may be given access to many virtual drives, allowing data to be accessed via many workstations without actually being transferred over a network. However, when capacity is allocated it is not wasted, in that blocks of two Mbytes are only allocated as actual storage is required.

5 In a preferred embodiment, it is envisaged that a server 20 would allow up to sixteen users to be connected thereto, although provision is made for server boxes to be connected in tandem, thereby providing access to a further 16 users for each box so connected.

10 The server 20 is detailed in Figure 2. Internally, a 32 bit parallel bus 25 provides communication between user interface circuits 26, disc drive interfaces 27, an internal processing unit 28 and internal program and data memory 29.

15 The server 20 is connected to each user interface 19 via a respective interface circuit 26 via two coaxial cables 30, providing a bi-directional link capable of conveying 100 Mbytes per second. Similarly, disc interface circuits 27 provide a parallel access to disc drives 21 through 25 and using connections of this type, it is necessary for disc drives 21 through 25 to be in close proximity to server box 20. In practice, the combination of server 20 along with disc drives 21 through 25 could be housed in a common 20 housing with a shared power supply. However, coaxial cables 30 allow the users to be positioned at a significant distance from the server 20 and the interfaces are such that they will allow runs in excess of 100 metres. Thus, these serial connections are similar or may take advantage of high speed ethernet links.

In an alternative embodiment, user processors 15 are connected to the server 20 via conventional SCSI interfaces which, although reducing the overall complexity of the system, also reduce the maximum distance between the server 20 and the processors 15.

5 An application of the system is illustrated in Figure 3. At step 41 a user identifies a logical disc, either by running server related software or, alternatively, in response to manual operations of a device connected to interface 19. Thus, if it is not possible to embed server software within a user's terminal, it is possible to provide interfaces 19 with additional control
10 devices such that, in response to manual operation of switches etc., commands are sent to server 20 so as to establish a logical disc connection.

 Communication of this type, allowing a user to send commands to the server 20, is achieved using vendor unique command blocks, which are data areas provided for specific proprietary applications within the SCSI standard.
15 Thus, in response to user originating commands, the server is instructed at step 42 to the effect that a user requires access to a logical drive.

 For each logical drive which may be made available to the users, it being noted that once a logical drive has been established by any particular user, other users may be given access to it, it is necessary for the server 20
20 to create a sector mapping table for that particular logical drive. Thus, in response to commands generated by a user's processor, establishing logical sectors of a SCSI disc, it is necessary for the server 20 to map these logical sectors onto physical blocks or groups of physical blocks stored within the physical drives 21 through 25. At the CPU 28, reference is made to a look-
25 up table stored within memory 29 which, as previously stated, identifies physical data blocks held by the redundant disc array. Thus, the CPU is

required to generate the sector instructions relevant for the physical drives 21 through 25, which are issued to respective ones of said drives via respective interface circuits 27.

5 Once a user has requested use of a logical drive, the server identifies the space available to the user at step 44, in response to which the user may identify particular files to be written to or read from the logical drive.

10 At step 46 it is determined whether the user wishes to write data to or read data from a logical drive. If data is being written to the drive, an enquiry is made at step 47 as to whether space is available on the last block to be written to. If space is available, data is written to the next identified block at step 48. Alternatively, if sufficient space is not available on the last block, a new block is selected at step 49 and data is written to this block at step 50.

15 If a read operation is identified at step 46, the physical blocks to be read are identified at step 51, the data is read at step 52 and supplied to the requesting user in a suitable form. Thereafter, the process may be repeated and further identifications may be made at step 41.

20 A schematic representation of the system is illustrated in Figure 4. At a workstation, a user is presented with a user interface, capable of providing an environment for allowing existing logical drives to be selected and providing the capacity for new drives to be defined.

The user interface 61 is in turn supported by a local operating system 62. Thus, an operator makes a file selection via user interface 61 and it is

then necessary for the local operating system 62 to generate commands which may be interpreted by the physical storage system.

As far as the local operating system 62 is concerned, the system is making access to conventional SCSI disc drives. Thus, the local operating system 62 communicates with a network interface, illustrated as 63 and physically consisting of interface 19 shown in Figure 1. The network interface 63 receives standard SCSI commands from the local operating system 62 and in turn generates modulated data for transmission over the serial link, shown as 64, connecting the network interface 63 to a server interface 64. A physical representation of server interface 64 is identified in Figure 2 as 26.

The transmission of data between the local operating system 62 and the network interface 63 conforms to establish SCSI protocols. However, the communication between network interface 63 and server interface 64 is internally defined by the system and is designed, in a preferred embodiment, to provide maximum data transfer rates over substantial lengths of cable, such as coaxial cable. Furthermore, the connection between the network interface 63 and the server interface 65 is bi-directional.

The network interface 63 is primarily concerned with driving signals generated by the local operating system 62 so that they may be transmitted over the serial communication link 64. However, the sector indications generated by the local operating system 62 are conveyed to the server interface 65 and it is the server operating system 66 which is required to convert SCSI sector selections into addresses for physical blocks located on the array of physical drives.

Thus, the server operating system 66 supplies addressing signals to the physical discs, identified as 67 whereafter data transfer is effected.

The server operating system 66 converts SCSI sector definitions into addressable physical data blocks by means of a look-up table, identified as 68.

5 A look-up table is defined for each logical drive and when a logical drive is selected by an operator its associated look-up table is loaded to an operating area of memory 29 within the server 20. Thus, within the operating system 66, a logical drive is identified, resulting in a table 68 being loaded. Thereafter, SCSI sector selections are supplied as inputs to said table, which

10 then results in addresses for physical data blocks being generated as outputs. Thus, as illustrated in Figure 4, the table 68 effectively points to addressable data blocks 69 in the array of physical data storing discs 21 through 25.

CLAIMS

1. A method of storing data wherein a plurality of user terminals access a large storage volume, comprising steps of
emulating the presence of a logical disc drive having a predetermined
5 capacity;
dividing said storage volume into a plurality of storage regions, wherein each of said regions is smaller than the size of an emulated logical disc drive; and
mapping said physical regions of data to an emulated drive
10 dynamically as additional storage is required, up to said predetermined capacity.
2. A method according to claim 1, wherein a plurality of logical drives are accessible to a user.
3. A method according to claim 2, wherein a look-up table is
15 associated with each accessible logical drive and a particular look-up table is loaded when its associated logical drive is selected.
4. A method according to any of claims 1 to 3, wherein the logical drives appear to a user system in a form compatible with a local physical disc drive.
- 20 5. A method according to claim 4, wherein said logical drive is connected via a small computer serial interface (SCSI).
6. A method according to any of claims 1 to 5, wherein the size of said regions is variable and pre-set for a particular application.

7. Apparatus for storing data, having a plurality of user terminals and means for each of said terminals to be given access to said stored data, comprising

5 means for emulating the presence of a logical disc drive having a predetermined capacity;

means for dividing a storage volume into a plurality of storage regions, wherein each of said regions is smaller than the size of an emulated logical disc drive; and

10 mapping means for mapping said physical regions of data to an emulated drive dynamically as additional storage is required, up to said predetermined capacity.

8. Apparatus according to claim 7, including means for defining a plurality of logical drives, each accessible to a user.

15 9. Apparatus according to claim 8, including means for defining a look-up table associated with each of said logical drives and means for loading a particular look-up table when its associated logical drive is selected.

10. Apparatus according to any of claims 7 to 9, including means for presenting a logical drive to a system user in a form compatible with a local physical disc drive.

20 11. Apparatus according to claim 10, wherein said logical disc drive is connectable via a small computer serial interface (SCSI).

12. Apparatus according to any of claims 7 to 11, including means for pre-setting the size of said regions for a particular application.

13. Apparatus according to any of claims 7 to 11, wherein the size of said regions is variable in response to operator requests and said means for emulating the presence of the logical drive is arranged to supply data to a user terminal identifying the size of a logical drive being emulated.

5 14. A method of storing data substantially as herein described with reference to the accompanying Figures.

15. Apparatus for storing data substantially as herein described with reference to the accompanying Figures.



The Patent Office

15

Application No: GB 9500173.1
Claims searched: 1-15

Examiner: Mr S J Probert
Date of search: 6 April 1995

**Patents Act 1977
Search Report under Section 17**

Databases searched:

UK Patent Office collections, including GB, EP, WO & US patent specifications, in:
UK CI (Ed.N): G4A AMX
Int CI (Ed.6): G06F 12/02
Other: Online Databases : WPI, INSPEC

Documents considered to be relevant:

Category	Identity of document and relevant passage	Relevant to claims
	None	

X Document indicating lack of novelty or inventive step	A Document indicating technological background and/or state of the art.
Y Document indicating lack of inventive step if combined with one or more other documents of same category.	P Document published on or after the declared priority date but before the filing date of this invention.
& Member of the same patent family	E Patent document published on or after, but with priority date earlier than, the filing date of this application.

An Executive Agency of the Department of Trade and Industry

This Page Is Inserted by IFW Operations
and is not a part of the Official Record

BEST AVAILABLE IMAGES

Defective images within this document are accurate representations of the original documents submitted by the applicant.

Defects in the images may include (but are not limited to):

- ① BLACK BORDERS
 - TEXT CUT OFF AT TOP, BOTTOM OR SIDES
 - FADED TEXT
 - ILLEGIBLE TEXT
 - SKEWED/SLANTED IMAGES
 - COLORED PHOTOS
- ① BLACK OR VERY BLACK AND WHITE DARK PHOTOS
 - GRAY SCALE DOCUMENTS

IMAGES ARE BEST AVAILABLE COPY.

**As rescanning documents *will not* correct images,
please do not report the images to the
Image Problem Mailbox.**

(12) UK Patent Application (19) GB (11) 2 297 636 (13) A

(43) Date of A Publication 07.08.1996

(21) Application No 9502377.6

(22) Date of Filing 02.02.1995

(71) Applicant(s)
Spring Consultants Limited
 (Incorporated in the United Kingdom)
 Unit 5, Ashbrook Mews, Westbrook Street,
 BLEWBURY, Oxon, OX11 9QA, United Kingdom

(72) Inventor(s)
 Norman Hamilton Burkles
 Andrew Paul George Randall

(74) Agent and/or Address for Service
 Atkinson & Co
 Sixth Floor, High Holborn House, 52-54 High Holborn,
 LONDON, WC1V 6SE, United Kingdom

(51) INT CL⁶
 G06F 3/06

(52) UK CL (Edition O)
 G4A AFS AMX

(56) Documents Cited
 EP 0078683 A2
 Dialog record 01425541 of UNIX Review, vol. 9, No.4,
 April 1991, page 98

(58) Field of Search
 UK CL (Edition N) G4A AFS AMX
 INT CL⁶ G06F 3/06
 ONLINE : WPI, INSPEC, COMPUTER DATABASE

(54) Storing data on emulated, logical, removable, disc drives

(57) Data is stored on a large storage volume implemented as a redundant array of five inexpensive discs (21-25). This volume is controlled so as to emulate the presence of a plurality of logical drives. Workstations (15,16) accessing the drives perceive them as removable SCSI drives. Consequently, when a remote workstation closes access to a previously accessed logical drive, a disc dismount command is generated, as required by a removable disc drive, thereby enabling other workstations to obtain access to that drive.

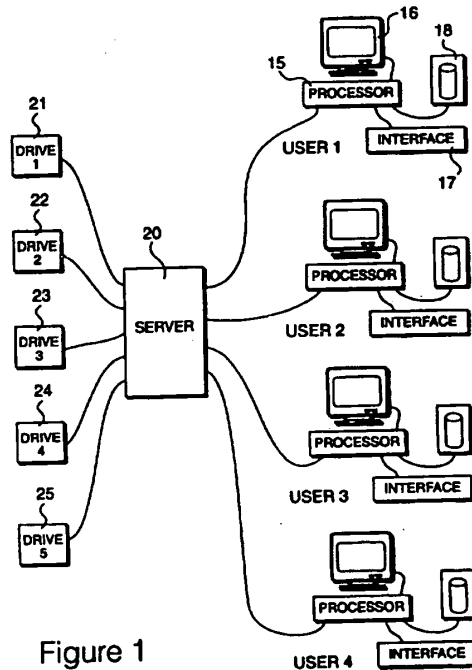

Figure 1

GB 2 297 636 A

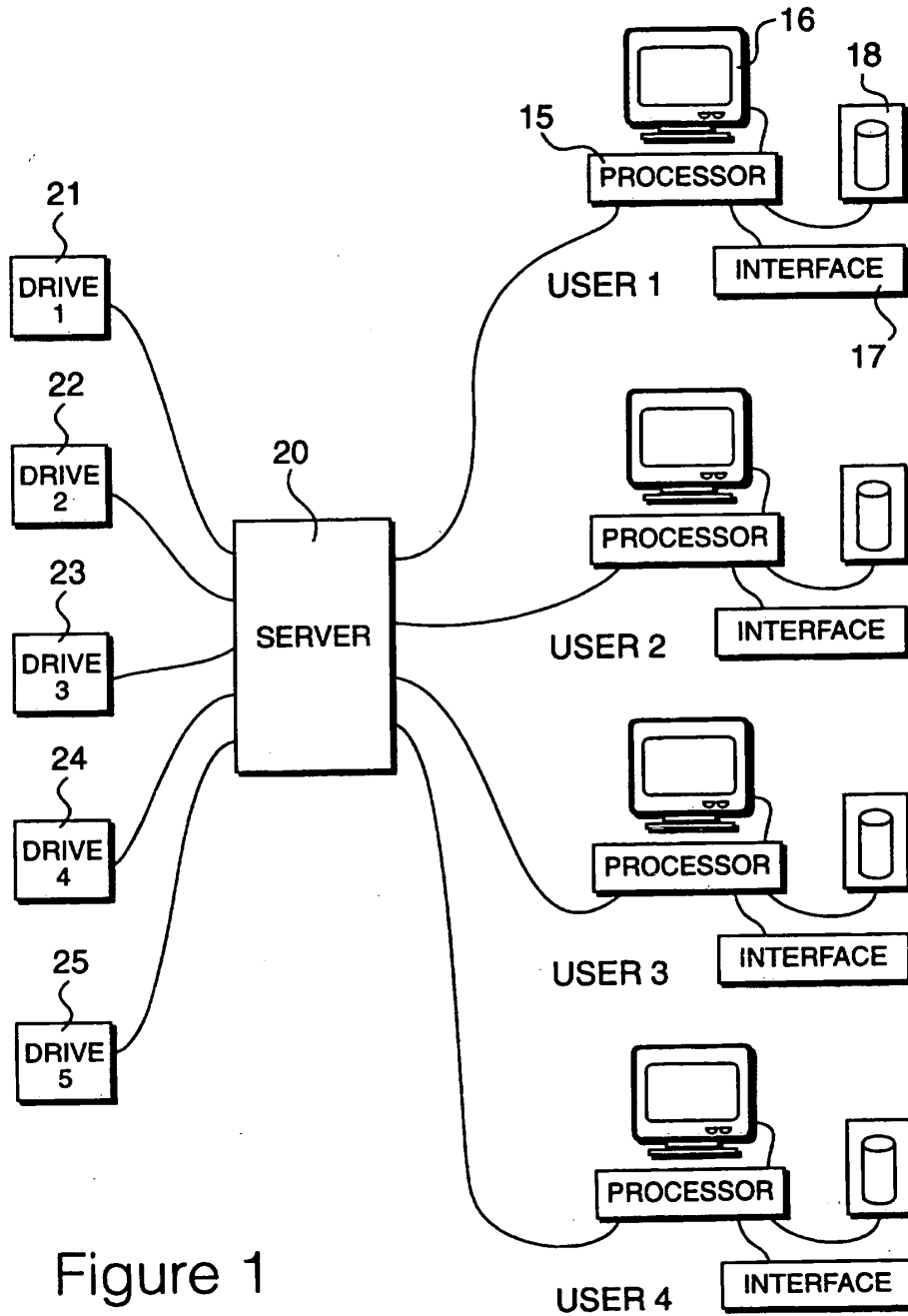

Figure 1

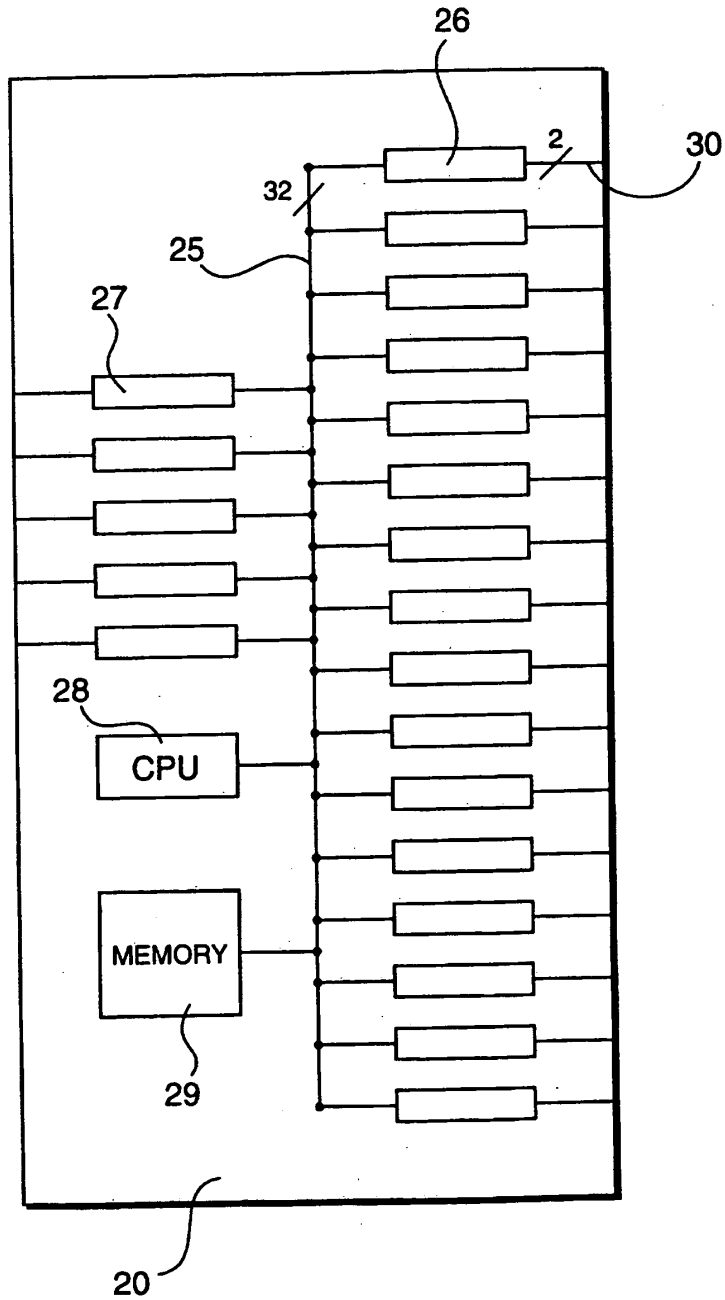

Figure 2

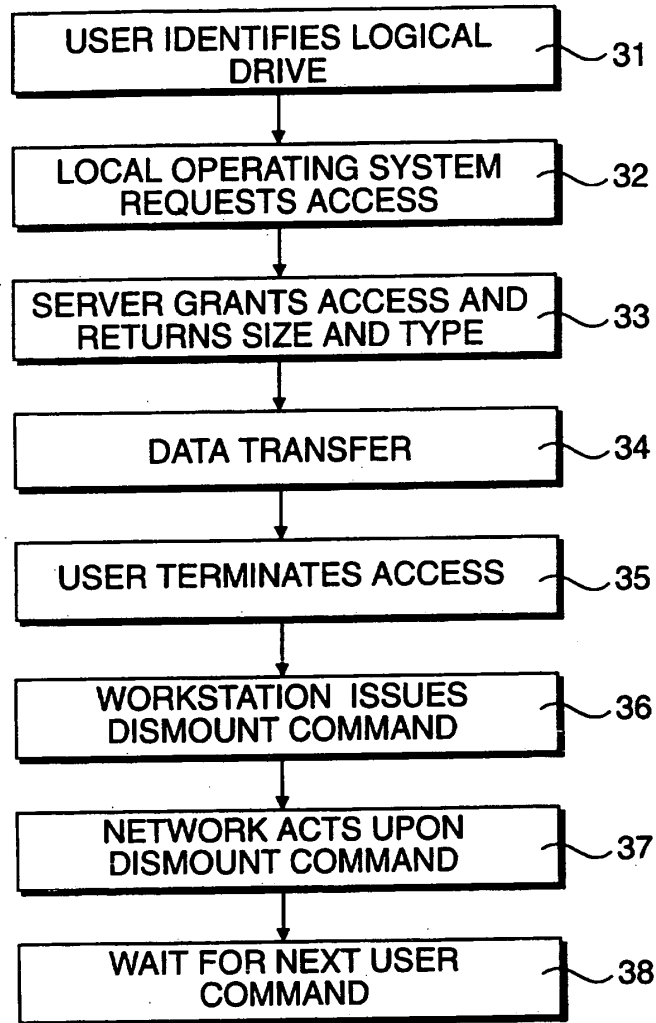

Figure 3

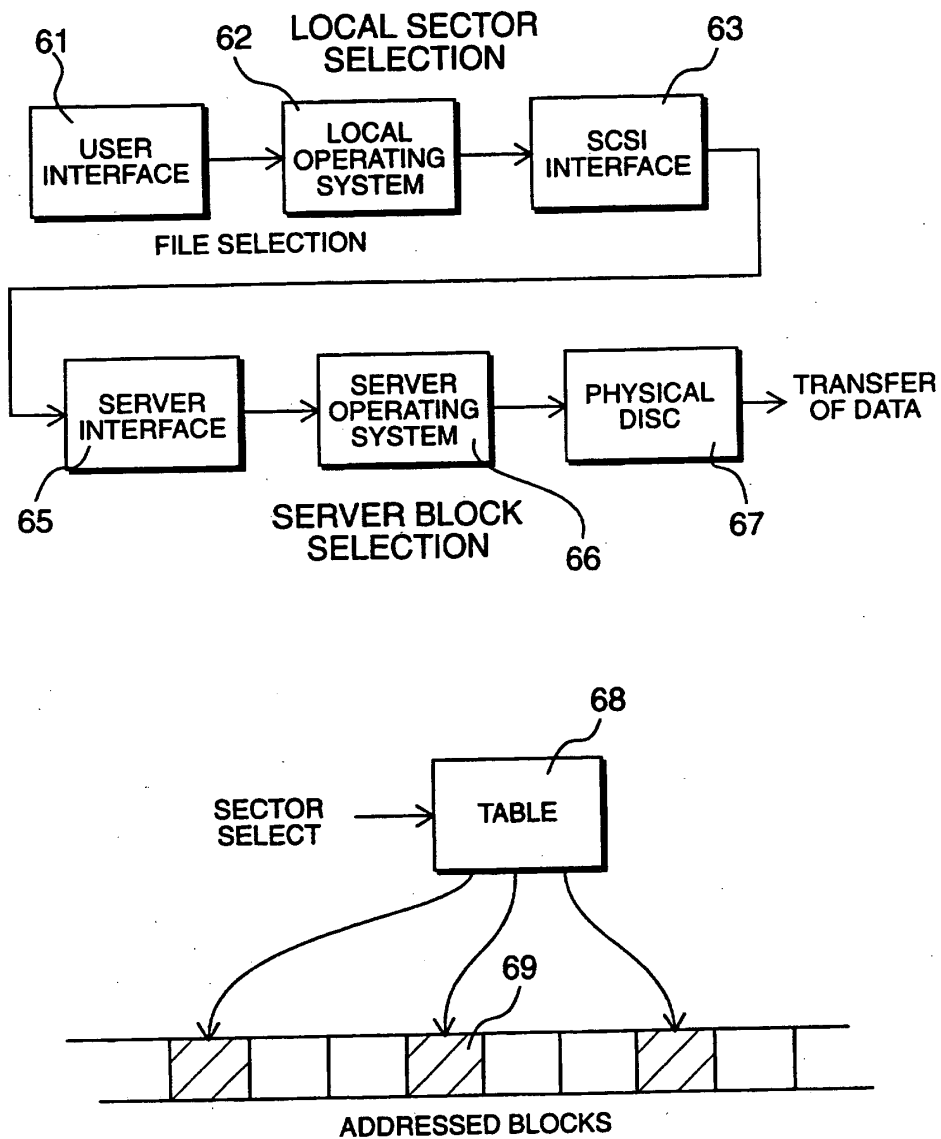

Figure 4

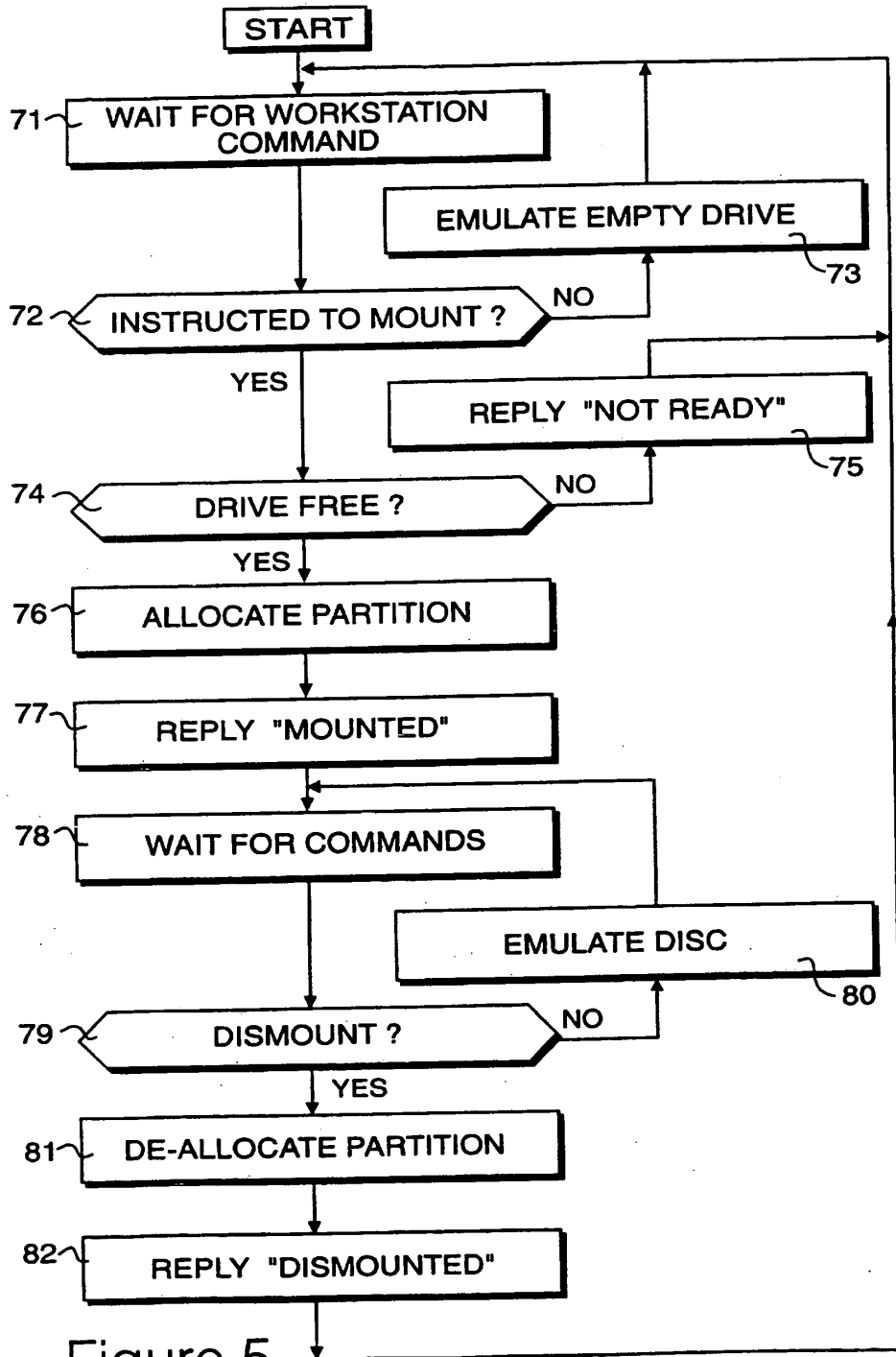

Figure 5

STORING DATA

The present invention relates to storing data. In particular, the present invention relates to large storage volumes controlled so as to emulate the presence of a plurality of logical drives.

Systems are known in which a large storage volume emulates the presence of a plurality of smaller volumes, which in turn may assist a user by facilitating logical arrangement of data, such that data of a first type may be kept separate from data of a second type. As far as an operating system is concerned, it has access to a plurality of drives as an alternative to having access to only one drive. Most operating systems are capable of controlling a plurality of logical drives in this way; within limits.

In more sophisticated environments, it is possible for a plurality of users to be given access to a shared volume divided into a plurality of logical drives. The division of the volume into a plurality of logical drives facilitates the interchange of information between users. Thus, a first user may log onto a logical drive, manipulate data contained within that drive and then log off, so as to allow another user to be given access to the logical drive. Such a procedure is particularly attractive when large data files are being handled, such as data files representing full colour graphic images, where the transfer of data, even over relatively fast networks, may take a considerable amount of time.

In addition, a large shared volume may be constructed first to provide relatively fast access times, along with levels of redundancy, such that a

single destructive event would not result in the whole data being lost, with recovery procedures being included as part of the overall structure.

5 Increasingly, computer workstations are being provided with localised processing capabilities having recognised and well supported operating systems. Examples are Apple Macintosh computers, IBM personal computers and Unix workstations etc. All of these systems have recognised protocols for the transfer of data. Thus, given the abundance of well supported operating systems, it is preferable to take full advantage of these operating systems so as to minimise the degree of bespoke software which needs to be generated and subsequently supported. System designs are restricted if full adherence to existing standards must be maintained, however, in some environments, an established system of operation may already be functional and the extent to which this system may be modified by the addition of new software etc., may be severely restricted. In some situations, the installation of a new suite of networking software may invalidate software agreements relating to primary localised processing.

20 In an environment in which a large storage volume emulates a plurality of discs, contention problems occur and the control processor must ensure that strict housekeeping routines are maintained, such that, for example, a previously accessed logical drive is properly deactivated when a particular user has finished with it, so that said drive may be accessed by other users and the overall integrity of this system is maintained. However, the degree to which network software requires to be embedded within workstation software should be minimised and it is undesirable for the network to place additional constraints on the workstations so as to assist the network's processing devices with their housekeeping tasks.

According to a first aspect of the present invention, there is provided a method of storing data, wherein a large storage volume emulates a plurality of logical drives; said logical drives emulate removable disc drives; and the closing of access to a previously accessed logical drive generates a disc
5 dismount command.

Thus, an advantage of the present invention is that the logical drives emulated by the large storage volume are presented to users in the form of removable disc drives, although in preferred practical realisations, they would actually be embodied within an environment of large fixed drives, so as to
10 optimise data capacity and disc access speed. However, operating systems for the individual workstations are fully conversant with the requirements of removable disc drives and, as required by the present invention, they will issue commands to said drives, informing the drive that access is no longer required.

15 In this way, it is possible to ensure that all necessary housekeeping procedures are effected when control over a logical disc drive is relinquished, either as part of normal operations or due to a software or hardware fault. Thus, for example, it is possible to ensure that directory information, cached in memory, is written back to disc, thereby updating the disc's directory,
20 before releasing access to the logical drive. Thus, by emulating removable drives of this type, workstation software will automatically provide the necessary levels of housekeeping in order to ensure that access to a logical drive is released when no longer required by a particular operator.

The local workstation will interface with a logical drive over standard
25 interfaces, provided for accessing removable disc drives. The workstation software will generate a disc dismount command and as far as the said

software is concerned, a dismount of the removable disc will be effected, thereby releasing the tie between the local workstation and that particular logical disc drive. However, within the network, this command will be interpreted to the effect that the processor no longer requires access to the logical drive, thereby allowing housekeeping procedures to be performed by the network processor.

Preferably, the logical drives emulate removable SCSI drives which may be capable of storing between 200 MBytes and 900 MBytes of data. According to a second aspect of the present invention there is provided apparatus, including a large storage volume; a control device arranged to control data transfer with said storage volume and to provide user terminal access to said storage volume by emulating the presence of a plurality of removable disc drives wherein user terminals generate a disc dismount command when closing access to a previously accessed logical drive; and the control device responds to said disc dismount command by terminating connection to said previously connected logical drive.

In a preferred embodiment, the control device is arranged to read directory information from an access logical drive and said directory information stored on the disc is updated in response to a disc dismount command.

The invention will now be described by way of example only, with reference to the accompanying figures, in which:

Figure 1 shows a system in which a plurality of workstations have access to a shared storage volume, including a file server;

Figure 2 details the file server shown in Figure 1;

Figure 3 details operations performed by the system shown in Figure 1; and

Figure 4 represents the logical operations effected by the system shown in Figure 1, including removable disc emulation;

Figure 5 details the removable disc emulation procedures performed by the file server shown in Figure 1.

A system is shown in Figure 1 in which a plurality of users have access to a shared storage volume. At each user workstation, the user is provided with a processor 15, a visual display unit 16, a keyboard, mouse or similar interface device 17 and a local disc drive 18.

Each processor 15 includes conventional software so as to implement an operating system, allowing data transfer between the processor 15 and the disc drive 18. In addition, the operating system also facilitates data transfer between the processors 15 and a shared file server 20. In this preferred embodiment, the file server 20 is connected to five physical hard disc drives 21, 22, 23, 24 and 25, which in combination provide a total of thirty-six GBytes of storage with an access speed of typically 10 MBytes per second.

Disc drives 21 to 25 are configured as a redundant array, in which actual data is stored on four of the drives, with parity data stored on the fifth. In this way, any one of the physical drives 21 to 25 may be removed from the system, possibly due to operational failure (head crash etc.) whereafter said data may be re-constituted from the data available from the other four.

Thus, data integrity and reliability are assured without the need for implementing regular back-up procedures. The use of a plurality of disc drives in this way is known in the art as a redundant array of inexpensive discs. In the preferred embodiment this is implemented in accordance with the RAID 5 recommendation.

Data is written to the drives in the form of identifiable blocks or regions of a predetermined length. The size of these blocks is determined from a trade-off between disc space optimisation and disc fragmentation. The system is primarily designed for storing large full colour graphics files and blocks have a size of, typically, between two MBytes and thirty-two MBytes, although block size may be configurable so as to suit particular applications. In operation, users issue commands under software control which result in logical drives being made available by the server 20. Communication between users and the server 20 is implemented using established protocols. In the preferred embodiment, the standard small computer systems interface (SCSI) is implemented and suitable interface cards are mounted in association with processor 15 and server 20. Thus, once a logical drive has been established by the server 20, this drive may be accessed by the user who perceives the drive as a conventional SCSI drive, accessed via conventional protocols within the local operating system.

The server 20 is arranged to provide access to a total of sixteen user workstations and a further sixteen workstations may be given access by connecting a similar server in tandem with the first. The server is detailed in Figure 2 and, internally, a thirty-two bit parallel bus 25 provides communication between the user interface circuits 26 and disc drive interfaces 27. The server is controlled in response to commands issued by the central

processing unit 28 which in turn receives programmed instructions from an internal memory device 29.

As previously stated, the server 20 is connected to each processor of a user workstation via a SCSI interface. The range of such interfaces is limited and in alternative embodiments it may be necessary to provide
5 alternative connections, possibly via coaxial cables, so as to increase the distance between the server and the workstations. It is therefore envisaged that systems will be designed specifically for particular applications, so as to optimise connections between workstations and the server. Thus, in some
10 environments, a large number of workstations may be provided relatively close to the server 20, in which case conventional SCSI interfaces may be employed whereas, in alternative arrangements, workstations may be distributed quite widely throughout a building, requiring more robust connections between the processors and the server 20. It is envisaged that
15 connections of this type should allow the workstations to be displaced from the server by distances in excess of 100 metres, having characteristics similar to high speed ethernet links.

Typical operation of the system shown in Figure 1 is detailed in Figure 3. As far as the operating system executable by each user workstation is
20 concerned, the workstation effectively has access to a large number of removable disc drives, although these are actually emulated by the server 20. In some situations, standard operating system software interfaces may be implemented within the user workstations so as to allow users to gain access to these logical drives. However, as the number of logical drives increases,
25 it may be necessary to improve the environment provided for users, so that they are aware of the presence of the disc drives and are provided with an interface which facilitates access to them. However, these user interfaces

would be overlaid over the operating system so that computer generated commands would result in instructions being generated at the operating system level.

5 Referring to Figure 3, a user identifies a logical disc drive to which access is required and identifies this logical disc drive at step 31. In response to the local request made at step 31, the local operating system implements measures to effect a request to access the logical disc drive, using conventional protocols. In particular, the processor 15 issues commands over the SCSI interface connected to the server 20.

10 In response to the request made at step 32, the server 20 will determine whether the logical disc drive is available and if the drive is available, it will grant access to the requesting workstation. As part of the SCSI protocol, the server will return data back to the requesting workstation, identifying the size of the logical drive and the drive type. Data relating to the drive type is very
15 relevant to the present invention. In particular, data is returned back to the requesting workstation identifying the drive type as a removable drive having, in the preferred embodiment, a total of 600 MBytes of available capacity.

20 Thus, it should be appreciated, that the emulated drives differ significantly from the actual physical drives in two respects. Firstly, the emulated drives are significantly smaller than the actual physical drives on which they are being emulated, primarily to ensure that a large number of such drives may be supported by the system. Secondly, the physical drives are actually fixed drives and remain permanently in place. Thus, when the server writes data to a particular physical location, the server is assured that
25 this physical location will remain in place and will not be exchanged for some other data storage medium. However, in the emulated environment, the

requesting processors are informed that the drives to which they are writing should be treated removable drives, effectively warning the processor that these drives may be replaced and that a subsequent data transfer operation to that particular drive would not necessarily result in the same information being available on the storage medium.

In the system itself, the emulated drives are not physically replaced by other recording media and it is not actually necessary for a physical dismounting operation to be performed when data access has been completed. However, by informing the remote processors that they are dealing with removable disc drives, the resulting dismount or unload command issued by the operating systems of the remote processors will ensure that the server has been instructed to the effect that the remote processors have completed their data transfer operations, thereby ensuring that the processor receives sufficient information for it to complete its housekeeping tasks, thereby allowing other workstations to be given access to emulated drives once they have been released from a data transfer operation.

Thus, to summarise, when the server 20 grants access to an emulated logical disc drive, it informs the requesting processor that it has been given access to a removable disc drive having a total capacity of 600 MBytes.

Conventionally, data is written to disc drives as identifiable blocks. In order to optimise available storage space, these blocks would normally reside on physical drives as contiguous regions of storage, effectively reducing fragmentation. However, it is not essential for the data to be perceived as residing in contiguous regions. In the present embodiment, the workstation processors may write data to the logical disc drives as they feel fit. Thus a logical disc drive may be perceived as being fragmented.

Thus, at step 34 data transfer takes place and the workstation's local operating software may read and write to the logical drives as if they were local removable disc drives. However, given the nature of the RAID 5 drives 21 to 25, the rate of data transfer is substantially higher and only restricted by the capabilities of the interface circuits employed. Thus, as far as the workstation processor is concerned, along with its operating software, it is interfacing with a standard removable disc drive. However, as far as the actual operator is concerned, the rate of data transfer is significantly higher and, due to the parallel nature of the array, said transfer rate significantly exceeds that available from fast local hard drives. Thus, the operator is provided with the advantage of fast data access while at the same time allowing data to be shared between a plurality of users as if the data were contained on removable exchangeable drives. Furthermore, the physical removing and exchange of drives is not necessary and only occurs at a logical level.

After data transfer has been completed, a user will normally take measures to terminate access to the logical drive. Thus, at step 35, a user may request access to another drive or implement alternative local processing operations. In either event, the workstation operating system issues a dismount command to the server 20 at step 36. This dismount command is required when the operating system has been given access to real dismountable drives which, as previously stated, is acted upon by the server 20 so as to complete the housekeeping procedures.

At step 37 the server 20 acts upon the dismount command by releasing the logical drive such that it may be accessed by other workstations. Thereafter, at step 38, the server waits for the next user command.

The releasing of a logical drive will include updating the directory for that drive. In order to improve disc access speed, disc directories are cached in memory and directory updates are made locally while the processor has access to the disc. Upon receiving the dismount command, the updated
5 directory information from the cache memory will be rewritten back to the directory on the disc, thereby maintaining the integrity of the directory data stored on the disk.

The system operating the software will be aware of the way in which removable disc directories are handled and the system will include measures
10 for accommodating power failures and program errors etc. Thus, measures can be taken to effect a disc reset, upon detecting that a particular partition has become unavailable or disconnected, whereafter, when access has been regained in that particular drive, information will be read to the effect that no assumptions may be made about the data contained on the disc and it would
15 be necessary to re-assess that data.

Although the system emulates logical drives having, for example, 600 MBytes of available storage, physical space on the RAID 5 drives 21 to 25 is actually allocated dynamically in regions as storage space for the storage of actual data is required. Thus, although users appear to be given access to
20 logical drives having a total of 600 MBytes, space on the actual RAID 5 drives is not divided into 600 MByte partitions. Drives 21 to 25 are divided into blocks of between two and thirty-two MBytes and blocks are allocated dynamically as and when they are required.

The actual size of blocks on the RAID 5 drives may be variable,
25 although it will be assumed herein that, for a particular application, two MByte blocks will be identified. As data is written to a logical drive, via the

server 20, the data will physically occupy an identifiable two MByte block. As the volume of data increases beyond two MBytes, the server 20 will identify a new two MByte data block and data originating from the user will then be directed to this new block. Thus, if a user has created a total of five
5 MBytes, the server is required to maintain a list of where these five MBytes actually reside on the drives, in terms of three two MByte blocks. However, as far as the user is concerned, five MBytes of data have been written to on a removable drive having a total of 600 MBytes of available capacity.

At a workstation, a user is presented with the user interface capable of
10 providing an environment for allowing existing logical drives to be selected and for new logical drives to be defined. The user interface 61 is in turn supported by a local operating system 62, which is responsible for generating commands which are in turn interpreted by the interface.

As far as the local operating system 62 is concerned, access is being
15 made to a conventional SCSI disc drive and communication is effected over a conventional SCSI interface 63, resident at the workstation, to a server SCSI interface 65. This communication conforms to establish SCSI protocols, thereby substantially reducing the need for embedding bespoke software within the local workstation environments.

20 A server operating system 66 converts SCSI sector definitions into addressable physical data blocks by means of a look-up table, identified by reference 68. A look-up table is defined for each logical drive and when a logical drive is selected by an operator, its associated look-up table is loaded to an operating area of memory 28 within the server 20. Thus, within the
25 server operating system 66, a logical drive is identified, resulting in a table 68 being loaded. Thereafter, SCSI sector selections are supplied as inputs to

the table, which then results in addresses for physical data blocks being generated as outputs. Thus, as illustrated in Figure 4, the table 68 effectively points to addressable data blocks 69 in the array of physical data storing discs 21 to 25.

5 The server operating system 66 allows the SCSI environment of the user terminal to interface with the emulated environment of the server. Thus, it is necessary for the server operating system to emulate an SCSI disc drive and procedures for performing this emulation are detailed in Figure 5.

10 The procedures shown in Figure 5 are executed within a multi-tasking environment, such that similar procedures may be performed for each of the user terminals. The procedures shown in Figure 5 therefore represent instructions executed on behalf of a particular workstation.

15 At step 71 the system waits for a workstation command and upon receiving such a command a question is asked at step 72 as to whether this is a "mount" command. A "mount" command instructs the server to mount a selected removable drive and data transfers via the server 20 can only be performed if the server has received such an instruction. Thus, if the question asked at step 72 is answered in the negative, control is directed to step 73, whereupon procedures are performed to emulate an empty drive. Thus, this
20 would include the generation of error messages to the effect that the drive is not ready etc.

25 If an instruction to mount a drive is generated by the workstation, the question asked at step 72 is answered in the affirmative, resulting in control being directed to step 74. At step 74 a question is asked as to whether the drive is free and if another user workstation has been given access to that

particular drive, the question asked at step 74 will be answered in the negative, resulting in a reply being generated at step 75 to the effect that the drive is not ready. Thereafter, control is returned to step 71. However, if the drive is free the question asked at step 74 is answered in the affirmative,
5 resulting in control being directed to step 76.

At step 76 a partition is identified representing the regions within which data for the emulated drive may be read from or written to. Thereafter, control is directed to step 77, whereupon a reply is returned back to the requesting workstation to the effect that the disk has been mounted and
10 control is directed to step 78.

At step 78 the server waits for further commands from the user workstation and in response to receiving such a command, a question is asked at step 79 as to whether this is a dismount command. If the command is not a dismount command further emulation of a removable disc is performed at
15 step 81 and control is returned to step 78.

Upon detecting a dismount command at step 79, control is directed to step 81, whereupon the partition is de-allocated and a reply is issued to the user workstation at step 82 to the effect that the disc has been dismounted. Thereafter control is returned to step 71, whereupon the server waits for the
20 next workstation command.

CLAIMS

1. A method of storing data, wherein a large storage volume emulates a plurality of logical drives; said logical drives emulate removable disc drives; and the closing of access to a previously accessed logical drive
5 generates a disc dismount command.
2. A method according to claim 1, wherein the logical drives emulate removable SCSI drives.
3. A method according to claim 2, wherein each of said logical drives provides between 200 MBytes and 900 MBytes of data storage.
- 10 4. A method according to any of claims 1 to 3, wherein data is written to the physical storage volume in identifiable blocks.
5. A method according to claim 4, wherein each of said blocks provides between one MByte and sixty-four MBytes of storage.
- 15 6. A method according to claim 4 or claim 5, wherein a mapping table maps sectors of an emulated disc onto blocks of the physical volume.
7. A method according to claim 4 or claim 5, wherein blocks are allocated dynamically as storage is required.
8. A method according to any of claims 1 to 7, wherein the storage volume is implemented as an array of disc storage devices.

9. A method according to claim 8, wherein the array has redundant discs.

10. A method according to claim 8 or claim 9, wherein the array has between four and twelve discs.

5 11. A method according to any of claims 1 to 10, wherein directory information stored on an accessed disc is updated in response to a disc dismount command.

10 12. A method according to any of claims 1 to 10, wherein directory information stored on an accessed disc is updated on detecting that a user terminal has been disconnected and can no longer access a previously accessed logical drive.

15 13. Data storage apparatus, including a large storage volume; a control device arranged to control data transfer with said storage volume and to provide user terminal access to said storage volume by emulating the presence of a plurality of removable disc drives, wherein user terminals generate a disc dismount command when closing access to a previously accessed logical drive; and the control device responds to said disc dismount command by terminating connection to said previously connected logical drive.

20 14. Apparatus according to claim 13, wherein the logical drives emulate removable SCSI drives.

15. Apparatus according to claim 14, wherein each of said logical drives provides between 200 MBytes and 900 MBytes of data storage.

16. Apparatus according to any of claims 13 to 15, wherein the control device is arranged to write data to the physical storage volume in the form of identifiable blocks.

5 17. Apparatus according to claim 16, wherein each of blocks provides between 1 MByte and 64 Bytes of storage.

18. Apparatus according to claim 16 or claim 17, wherein the control device is arranged to access mapping tables, mapping sectors of an emulated disc onto blocks of the physical volume.

10 19. Apparatus according to any of claims 16 to 18, wherein the control device is arranged to dynamically allocate blocks as storage is required.

20. Apparatus according to any of claims 13 to 19, where the storage volume is implemented as an array of disc storage devices.

15 21. Apparatus according to claim 20, wherein the array includes redundant discs.

22. Apparatus according to claim 20 or claim 21, wherein the array has between four and 12 discs.

20 23. Apparatus according to any of claims 13 to 22, wherein the control device is arranged to read directory information from an accessed logical drive, and the directory information stored on the disc is updated in response to a disc dismount command.

24. Apparatus according to any of claims 13 to 22, wherein the control device is arranged to read directory information from an accessed logical drive and directory information stored on a logical disc drive is updated by the control device in response to detecting that a user terminal has been disconnected and can no longer access a previously accessed logical drive.

25. A method of storing data substantially as herein described with reference to the accompanying drawings.

26. A data storage apparatus substantially as herein described with reference to the accompanying drawings.



The
Patent
Office

19

Application No: GB 9502377.6
Claims searched: 1-26

Examiner: Geoff Western
Date of search: 3 May 1995

Patents Act 1977
Search Report under Section 17

Databases searched:

UK Patent Office collections, including GB, EP, WO & US patent specifications, in:

UK Cl (Ed.N): G4A (AFS, AMX)

Int Cl (Ed.6): G06F (3/06)

Other: On-line : WPI, INSPEC, COMPUTER DATABASE

Documents considered to be relevant:

Category	Identity of document and relevant passage	Relevant to claims
A	EP-0078683-A2 (FUJITSU) See whole document	-
A	Dialog record 01425541 of UNIX Review, vol 9, No 4, April 1991, page 98	.

X	Document indicating lack of novelty or inventive step	A	Document indicating technological background and/or state of the art.
Y	Document indicating lack of inventive step if combined with one or more other documents of same category.	P	Document published on or after the declared priority date but before the filing date of this invention.
&	Member of the same patent family	E	Patent document published on or after, but with priority date earlier than, the filing date of this application.

An Executive Agency of the Department of Trade and Industry

IN THE UNITED STATES PATENT AND TRADEMARK OFFICE	
INFORMATION DISCLOSURE STATEMENT BY APPLICANT	Atty. Docket No. (Opt.) CROSS1120-13

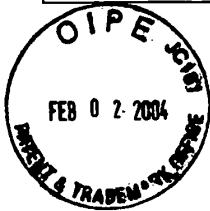

Applicants Geoffrey B. Hoese, et al.	
Application Number 10/658,163	Filed September 9, 2003
For STORAGE ROUTER AND METHOD FOR PROVIDING VIRTUAL LOCAL STORAGE	
Group Art Unit 2186	Examiner Unknown

Commissioner for Patents
P.O. Box 1450
Alexandria, VA 22313-1450

Certificate of Mailing
I hereby certify that this correspondence is being deposited with the U.S. Postal Service as First Class Mail in an envelope addressed to: Commissioner for Patents, P.O. Box 1450, Alexandria, VA 22313-1450 on <u>Jan 30</u> 2004.
 Laura M. McGuire

Applicants respectfully request, pursuant to 37 C.F.R. §§ 1.56, 1.97 and 1.98, that the art listed on the attached SB08A and SB08B forms be considered and cited in the examination of the above-identified application. A copy of the art is enclosed for the convenience of the Examiner. Furthermore, pursuant to 37 C.F.R. §§ 1.97(g) and (h), no representation is made that a search has been made or that this art is material to patentability of the present application.

Applicants respectfully submit that the claims of Applicants' above-referenced patent application are patentably distinguishable from these references.

Respectfully submitted,

Gray Cary Ware & Freidenrich LLP
Attorneys for Applicant

John L. Adair
Reg. No. 48,828

Dated: 1/28/04
1221 S. MoPac Expressway, Suite 400
Austin, Texas 78746
Tel. (512) 457-7142
Fax. (512) 457-7001

AU4121177.1
103671-990004

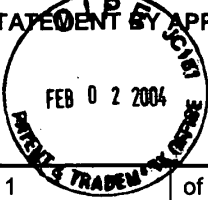
INFORMATION DISCLOSURE STATEMENT BY APPLICANT 		Application Number	10/658,163		
		Filing Date	September 9, 2003		
		First Named Inventor	Geoffrey B. Hoese, et al.		
		Group Art Unit	2186		
		Examiner Name	Unknown		
Sheet	1	of	1	Attorney Docket Number	CROSS1120-13
NON-PATENT LITERATURE DOCUMENTS					
	C1	DIGITAL StorageWorks, Using Your HSZ70 Array Controller in a SCSI Controller Shelf (DS-BA356-M Series), <i>User's Guide</i> , pp. 1-1 through A-5 with index, January 1998.			
	C2	DIGITAL StorageWorks, HSZ70 Array Controller HSOF Version 7.0 (EK-HSZ70-CG.A01) <i>Configuration Manual</i> , pp. 1-2 through G15 with index, July 1997.			
	C3	DIGITAL StorageWorks, HSZ70 Array Controller HSOF Version 7.0, <i>CLI Reference Manual</i> , pp. 1-156, July 1997.			
Examiner Signature				Date Considered	



USPTO COPY OF REFERENCES SUBMITTED IN IDS

Application Number	10/658,163
Filing Date	September 9, 2003
First Named Inventor	Geoffrey B. Hoese, et al.
Group/Art Unit	2186
Examiner Name	Unknown
Attorney Docket Number	CROSS1120-13

Gray Cary\AU4121188.1
103671-990004



11-24-03

\$

IN THE UNITED STATES PATENT AND TRADEMARK OFFICE	
PETITION TO MAKE SPECIAL BECAUSE OF ACTUAL INFRINGEMENT PURSUANT TO 37 C.F.R. § 1.102 AND M.P.E.P. 708.02(II)	Atty. Docket No. (Opt.) CROSS1120-13
Applicant Geoffrey B. Hoese, et al.	
Application Number 10/658,163	Filed September 9, 2003
For Storage Router and Method for Providing Virtual Local Storage	
Group Art Unit Unknown	Examiner Unknown
Confirmation Number: Unknown	

11/26/2003 SDIRETA1 00000013 500456 10658163

01 FC:1051 130.00 DA

Via Facsimile (703) 306-5404 and Express Mail

Commissioner for Patents
P.O. Box 1450
Alexandria, VA 22313-1450

Dear Sir:

<u>Certificate of Mailing Under 37 C.F.R. 1.10</u>
I hereby certify that this correspondence is being deposited with the United States Postal Service as Express Mail No. EV351127304US in an envelope addressed to: Commissioner for Patents, P.O. Box 1450, Alexandria, VA 22313-1450 on November 21, 2003.
 Katherin Cope

SNH0E2PTT5EVA3

Applicants submit this Petition to the Commissioner under 37 C.F.R. § 1.102 and M.P.E.P. 708.02(II) to make special and advance the examination of the above-identified application because of actual infringement. Applicants submit that this Petition meets all of the requirements of 37 C.F.R. § 1.102 and M.P.E.P. 708.02(II) for a grantable petition.

This petition is accompanied by a Declaration by Robert Griswold in Support of the Petition to Make Special Because of Actual Infringement. If a further showing in support of this Petition is deemed necessary, Applicants invite the Examiner to call the undersigned to obtain the required showing.

Applicants hereby file this petition to make special and request that this petition be granted and that the application be allowed.

Applicants point out that the references which are believed to be the most closely related to the subject matter encompassed by the claims are already of record in the parent applications.

Gray Cary\AU4117803.1
103671-990004

Authorization is hereby given to deduct \$130.00 from Deposit Account No. 50-0456 of Gray Cary Ware & Freidenrich LLP representing the filing fee for this petition to make special because of actual infringement, as set forth in 37 C.F.R. § 1.17(h). While no other fees are believed due, authorization is given to charge any additional fees or credit any overpayments in connection with this petition to Deposit Account No. 50-0456.

In view of this petition, in the event that there remain matters to be resolved in this application, the Examiner is invited to call the undersigned so that a prompt disposition of the application can be achieved.

Respectfully submitted,

Gray Cary Ware & Freidenrich LLP



John L. Adair
Registration No. 48,828

Dated: November 21, 2003

1221 South MoPac Expressway, Suite 400
Austin, Texas 78746
Telephone: (512) 457-7142
Facsimile: (512) 457-7001

2182

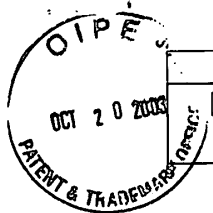

IN THE UNITED STATES PATENT AND TRADEMARK OFFICE

INFORMATION DISCLOSURE STATEMENT BY APPLICANT

Atty. Docket No.
CROSS1120-13

RECEIVED
OCT. 22 2003
Technology Center 2100

Applicants: Geoffrey B. Hoese, et al.	
Application Number 10/658,163	Filed September 9, 2003
For: Storage Router and Method for Providing Virtual Local Storage	
Group Art Unit Unknown	Confirmation Number Unknown
Application No. 10/658,163	Filing Date of Parent September 9, 2003
Group Art Unit of Parent 2182	Examiner of Parent Christopher Shin

Mail Stop: Patent Application
Commissioner for Patents
P.O. Box 1450
Alexandria, VA 22313

Certification Under 37 C.F.R. §1.10

I hereby certify that this document is being deposited with the United States Postal Service as Express Mail to Addressee in an envelope addressed to Commissioner for Patents, P.O. Box 1450, Alexandria, VA 22313 on **October 17, 2003**.

Laura McGuire

Applicants respectfully request, pursuant to 37 C.F.R. §§ 1.56, 1.97 and 1.98, that the art listed on the attached PTO/SB/08A form be considered and cited in the examination of the above-identified continuation application. Pursuant to 37 C.F.R. §§ 1.97(g) and (h), no representation is made that a search has been made or that this art is material to patentability of the present application. Applicants respectfully submit that the claims of Applicants' above-referenced patent application are patentably distinguishable from these references.

In the prosecution of United States Patent Application Serial Number 10/081,110 (the "110 Application"), the parent of the present application, Applicants submitted trial exhibits from *Crossroads Systems, Inc. v. Pathlight Technology, Inc.*, 1:00cv00248 (W.D. Tex.) (the "Pathlight Litigation") and *Crossroads Systems, Inc. v. Chaparral Network Storage, Inc.*, 1:00cv00217 (W.D. Tex.) (the "Chaparral litigation"). Several of these trial exhibits included United States and foreign patents. The Examiner requested that the Applicants separately list patent references from the trial exhibits. Accordingly, the attached PTO/SB/08A form includes, among other references, references that were previously submitted as part of the trial exhibits. To the extent that any of references A1-A16 were separately listed in the prosecution of the '110 Application, Applicants are submitting them again to comply with the Examiner's request to call out patents found the trial exhibits. The following summarizes the listed references for the convenience of the Examiner.

AU4115815.1
103671-990004

References A1-A7 were each included in the exhibits from both the Chaparral litigation and the Pathlight litigation. References A9-11 and B1-B3 were included in the exhibits from the Chaparral litigation. References A8 and A12-A16 were included in the exhibits from the Pathlight litigation. Copies of references A1-A16 are included for the Examiner's convenience. Applicants note that in the Pathlight Litigation and the Chaparral litigation, Crossroads Systems Inc., asserted United States Patent Number 5,941,972 (the "972 Patent") against the respective defendants. The Pathlight Litigation settled with a consent decree that the '972 Patent is valid.

References A19-A30 and A33-A46 were cited in an Office Action mailed January 21, 2003 in related United States Patent Application Serial Number 10/174,720. Copies of references A19-A30 and A33-A46 are enclosed.

Reference A47 was cited in the Notice of Allowance for United States Patent Application Serial Number 10/174,720. A copy of reference A47 is enclosed for the Examiner's convenience.

Additional references include A17-A18, A31-A32, B4, C1-C3. Copies of these references are included for the convenience of the Examiner.

While Applicants believe no fees are due, if any fees are due, the Commissioner is hereby authorized to charge Deposit Account No. 50-0456 of Gray Cary Ware & Freidenrich LLP.

Respectfully submitted,

Gray Cary Ware & Freidenrich LLP
Attorneys for Applicants



John L. Adair
Reg. No. 48,828

Dated: October 16, 2003

1221 S. MoPac Expressway, Suite 400
Austin, Texas 78746
Tel. (512) 457-7142
Fax. (512) 457-7001

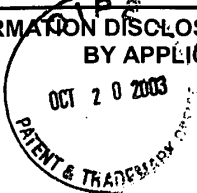
INFORMATION DISCLOSURE STATEMENT BY APPLICANT				Application Number	10/658,163	
				Filing Date	September 9, 2003	
				First Named Inventor	Geoffrey Hoese	
				Group Art Unit	Unknown	
				Examiner Name	Unknown	
Sheet	1	of	3	Attorney Ref. Number	CROSS1120-13 Technology Center 2100	
U.S. PATENT DOCUMENTS						
Examiner Initials	Cite No.	Document Number		Publication Date MM-DD- YYYY	Name of Patentee or Applicant of Cited Document	Pages, Columns, Lines Where Relevant Passages or Figures Appear
		Number	Kind Code (if known)			
	A1	5,748,924	--	05/05/98	Llorens, et al.	
	A2	5,768,623	--	06/16/98	Judd, et al.	
	A3	5,809,328	--	09/15/98	Nogales, et al.	
	A4	5,812,754	--	09/22/98	Lui, et al.	
	A5	5,835,496	--	11/10/98	Yeung, et al.	
	A6	5,848,251	--	12/08/98	Lomelino, et al.	
	A7	5,941,972	--	08/24/99	Hoese, et al.	
	A8	6,041,381	--	03/21/00	Hoese	
	A9	6,145,006	--	11/07/00	Vishlitsky et al.	
	A10	6,219,771	B1	04/17/01	Kikuchi et al.	
	A11	6,260,120	B1	07/10/01	Blumenau et al.	
	A12	3,082,406	--	03/19/63	L.D. Stevens	
	A13	4,092,732	--	05/30/78	Ouchi	
	A14	4,947,367	--	08/07/90	Chang et al.	
	A15	5,072,378	--	12/10/91	Manka	
	A16	5,465,382	--	11/07/95	Day, III et al.	
	A17	5,947,530	--	10/26/99	Young	
	A18	6,529,996	B1	03/04/03	Nguyen et al.	
Examiner Initials	Cite No.	FOREIGN PATENT DOCUMENTS		Publication Date MM-DD- YYYY (Number 43)	Name of Patentee or Applicant of Cited Document	Pages, Columns, Lines Where Relevant Passages or Figures Appear
		Country Code	Number			
	B1	EP 0827059	A2	03/04/98	NEC Corporation	
	B2	JP 8-230895	--	09/10/96	Kikuchi et al.	
	B3	WO 99/34297	A1	07/08/99	Crossroads Systems, Inc.	
	B4	EP 0810 530	A2	12/03/97	Sun Microsystems, Inc.	
Examiner Signature				Date Considered		

INFORMATION DISCLOSURE STATEMENT BY APPLICANT				Application Number	Unknown	
				Filing Date	Herewith	
				First Named Inventor	Geoffrey Hoese	
				Group Art Unit	Unknown	
				Examiner Name	Unknown	
Sheet	2	of	3	Attorney Ref. Number	CROSS1120-1 technology Center 2100	
U.S. PATENT DOCUMENTS						
Examiner Initials	Cite No.	Document Number		Publication Date MM-DD- YYYY	Name of Patentee or Applicant of Cited Document	Pages, Columns, Lines Where Relevant Passages or Figures Appear
		Number	Kind Code (if known)			
	A19	5,864,653	--	01/26/99	Tavallaei et al.	
	A20	6,070,253	--	05/30/00	Tavallaei et al.	
	A21	5,884,027	--	03/16/99	Garbus et al.	
	A22	6,131,119	--	10/10/00	Fukui	
	A23	5,729,705	--	03/17/98	Weber	
	A24	5,751,975	--	05/12/98	Gillespie et al.	
	A25	5,680,556	--	10/21/97	Begun et al.	
	A26	5,581,714	--	12/03/96	Amini et al.	
	A27	5,774,683	--	06/30/98	Gulick	
	A28	6,330,629	B1	12/11/01	Kondo et al.	
	A29	5,845,107	--	12/01/98	Fisch et al.	
	A30	4,695,948	--	09/22/87	Blevins et al.	
	A31	5,598,541	--	01/28/97	Malladi	
	A32	5,163,131	--	11/10/92	Row et al.	
	A33	5,414,820	--	10/09/95	McFarland et al.	
	A34	5,857,080	--	01/05/99	Jander et al.	
	A35	5,941,969	--	08/24/99	Ram et al.	
	A36	6,223,266	B1	04/24/01	Sartore	
	A37	5,991,797	--	11/23/99	Futral et al.	
	A38	5,257,386	--	10/26/93	Saito	
	A39	5,701,491	--	12/23/97	Dunn et al.	
Examiner Signature				Date Considered		

This Page Is Inserted by IFW Operations
and is not a part of the Official Record

BEST AVAILABLE IMAGES

Defective images within this document are accurate representations of the original documents submitted by the applicant.

Defects in the images may include (but are not limited to):

- BLACK BORDERS
- TEXT CUT OFF AT TOP, BOTTOM OR SIDES
- FADED TEXT
- ILLEGIBLE TEXT
- SKEWED/SLANTED IMAGES
- COLORED PHOTOS
- BLACK OR VERY BLACK AND WHITE DARK PHOTOS
- GRAY SCALE DOCUMENTS

IMAGES ARE BEST AVAILABLE COPY.

**As rescanning documents *will not* correct images,
please do not report the images to the
Image Problem Mailbox.**



(12) **EUROPEAN PATENT APPLICATION**

(43) Date of publication:
04.03.1998 Bulletin 1998/10

(51) Int. Cl.⁶: **G06F 1/00, G06F 3/06**

(21) Application number: **97114612.1**

(22) Date of filing: **22.08.1997**

(84) Designated Contracting States:
**AT BE CH DE DK ES FI FR GB GR IE IT LI LU MC
 NL PT SE**
 Designated Extension States:
AL LT LV RO SI

(72) Inventors:
 • **Kikuchi, Yoshihide**
Minato-ku, Tokyo 108-01 (JP)
 • **Akagi, Masanobu**
Minato-ku, Tokyo 108-01 (JP)

(30) Priority: **30.08.1996 JP 230895/96**

(74) Representative:
**von Samson-Himmelstjerna, Friedrich R., Dipl.-
 Phys.**
SAMSON & PARTNER
Widenmayerstrasse 5
80538 München (DE)

(71) Applicant: **NEC Corporation**
Minato-ku, Tokyo 108-01 (JP)

(54) **Disk apparatus**

(57) The apparatus enables access authorization to be assigned solely to specific host devices. A control device (106) comprises: an address registration unit (104), in which the host address of each host device has been registered for authorizing access, a command interpretation and execution unit (102) which on receipt of a command from a host device via a host device interface outputs the host address of the host device based on the command, and an address verification unit (103) for verifying the host address output from a command

interpretation and execution unit (102) against the host address registered in the address registration unit (104), as well as determining whether or not the particular host device has access authorization. The command interpretation and execution unit (102) incorporates an authorization pending function, so that on receipt of a command from a host device, the command is interpreted and executed only after access is authorized by the address verification unit (103).

FIG.1

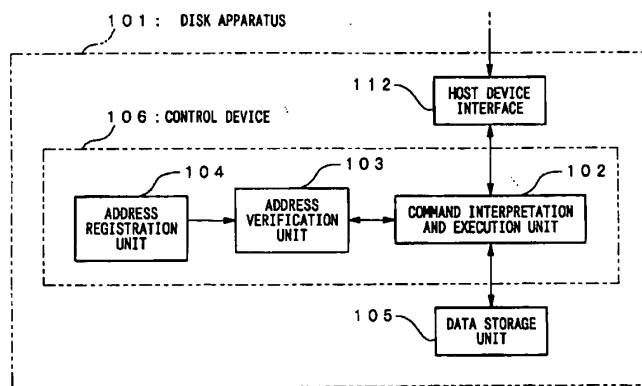

EP 0 827 059 A2

Description**BACKGROUND OF THE INVENTION****Field of the Invention**

The present invention relates to a disk apparatus, and in particular to a disk apparatus which can be accessed by a plurality of host devices.

Description of the Related Art

With conventional disk apparatus, each host controls the disk or disk array directly, and disk security is controlled by the host device to which the disk is connected. File sharing with this type of file server client system is disclosed for example in Japanese Patent Application, First Publication No. Hei-4-58349.

A block diagram showing the configuration of a conventional disk apparatus is shown in Figure 6. A conventional disk apparatus 201 comprises a command interpretation and execution unit 202 which interprets commands from a host device as well as executing those commands, and a data storage unit 203 in which data is stored. The command interpretation and execution unit 202, in the case of a read command for example, interprets the command, and recognizing the command as a read command directs the data storage unit 203 to read. The data storage unit 203 reads the stored data based on the read directions from the command interpretation and execution unit 202, and then transfers the data to the host device.

Common ways of connecting the host device and the disk apparatus include a SCSI (Small Computer System Interface) and Fibre Channel. Consequently, the command interpretation and execution unit 202 interprets commands from the SCSI or Fibre Channel and then outputs commands such as read and/or write, to the disk data storage unit 203.

With this type of conventional disk apparatus, usually a single host device is connected to the disk apparatus. Furthermore, even in those cases where a plurality of host devices are connected to a common disk interface, with current technology it is possible for any of the host devices to access the disk.

With advances in technology relating to the interface between the host device and the disk apparatus however, it has become feasible to connect a plurality of host devices. Using Fibre Channel, it is possible for example to use loops (FC-AL) to connect together more than 100 devices including both host devices and disk apparatus. Moreover, if switching fabric is employed the number of devices which can be connected together increases even further. Utilizing the high speed of interfaces, it is also possible to connect a plurality of host devices and disk apparatus to a single interface. With conventional disk apparatus, a problem arises that in the case where a single disk is able to be accessed by

a plurality of hosts devices, access authorization can not be restricted to specific host devices.

Furthermore, with the move to large volume disk apparatus, it is possible to consider partitioning a single disk and then having each host use a different partition, but with conventional disk apparatus it has not been possible, while using a single interface, to identify a host device and then have each host device use a different partition.

SUMMARY OF THE INVENTION

It is an object of the present invention to improve the deficiencies inherent in the conventional devices discussed above, and in particular to provide a disk apparatus in which each host device can be treated differently, so that for example access authorization can be assigned solely to specific host devices, or furthermore, each host device can gain access to a different partition while using the same interface.

A first apparatus according to the present invention comprises: a host device interface for sending and receiving data to and from a plurality of host devices, a data storage device for storing data to be sent to a host device, and a control device for controlling the writing of data to, and the reading of data from, the data storage device.

The control device comprises an address registration unit, in which the host address of each host device has been registered in advance, for the purpose of authorizing access, a command interpretation and execution unit which on receipt of a command from a host device via the host device interface outputs the host address of the host device based on the command, and an address verification unit for verifying the host address output from the command interpretation and execution unit against the host address registered in the address registration unit, and for determining whether or not the particular host device has access authorization. The command interpretation and execution unit is configured to include an authorization pending function, so that on receipt of a command from a host device, the command is interpreted and executed only after access is authorized by the address verification unit.

With this first apparatus, the host address is extracted from the command sent from a host device and verified against those host addresses registered in the address registration unit for the purpose of determining access authorization. As a result, if access is authorized, the disk apparatus accepts the command which has been sent and disk read/write functions are performed. In this way, only authorized host devices gain access to the data storage unit.

As a second apparatus according to the present invention a construction is adopted where, in addition to the items which characterize the first apparatus, a host information storage unit in which information about the hosts such as host names and passwords is stored, is

incorporated into the address registration unit, and a host check unit which, on receipt of host information from a host, determines whether or not that particular host has access authorization based on the host information received from the host and the host information stored in the host information storage unit, is incorporated into the command interpretation and execution unit, and this host check unit incorporates an address registration function which registers the access authorization based on the host information, and the host address determined for the host device, in the address registration unit.

With this second apparatus, when a host device logs in to the disk apparatus seeking authorization to use the disk, the address is registered in the address registration unit, and subsequently, the host address is extracted from any commands sent from the host device and verified against the host address registered in the address registration unit, and in those cases where access is authorized the command interpretation and execution unit transmits the command from the host device to the data storage unit and executes the command. In this way, any alterations in host address can be easily accommodated.

With a third apparatus, a construction is adopted where in addition to the items which characterize the second apparatus, the host check unit incorporates a startup setting function which requests host information from a plurality of host devices when the control device is activated.

With this third apparatus, host information relating to access authorization is not stored internally beforehand, but rather is sent from the host devices which control the disk at the point of disk startup. Consequently, the amount of non volatile memory set aside for data storage can be reduced.

As a fourth apparatus according to the present invention a construction is adopted where, in addition to the items which characterize the first apparatus, the control device comprises: an offset information generation unit, which on the basis of a host address output from the command interpretation and execution unit generates offset information for the disk partition for that particular host device, and an actual partition address generation unit which on the basis of the address for reading and writing to the disk apparatus, and the offset information, generates an actual disk partition address and then outputs that actual partition address to the command interpretation and execution unit.

With this fourth apparatus, the disk capacity is partitioned amongst the various host devices, and the various host addresses and the offset information for each partition are coordinated beforehand. When a command is received from a host device, the command interpretation and execution unit extracts the host address from the command and sends it to the offset information generation unit. The offset information generation unit then uses a correlation chart of host devices

and offset information which has been stored in advance, and generates offset information which corresponds to the particular host device and sends this information to the actual partition address generation unit. The actual partition address generation unit combines the theoretical disk address included in the command from the host device and the offset information, and generates an actual disk partition address. In this way, the disk partition corresponding to the host device from which the command was sent is accessed.

BRIEF DESCRIPTION OF THE DRAWINGS

Figure 1 is a block diagram showing the configuration of a first embodiment of the present invention;

Figure 2 is an explanatory diagram displaying a phase transition state of a SCSI bus;

Figure 3 is a block diagram showing an example configuration of hardware resources of a disk apparatus according to the first embodiment shown in Figure 1;

Figure 4 is a block diagram showing the configuration of a second embodiment of the present invention;

Figure 5 is a block diagram showing the configuration of a third embodiment of the present invention; and

Figure 6 is a block diagram showing a configuration based on current technology.

DESCRIPTION OF THE PREFERRED EMBODIMENTS

Next is a description of the preferred embodiments of the present invention, with reference to the drawings.

First embodiment

A block diagram showing the configuration of a disk apparatus according to a first embodiment of the present invention is shown in Figure 1. As is shown in Figure 1, a disk apparatus 101 comprises a host device interface 112 for sending and receiving data to and from a plurality of host devices, a data storage device (data storage unit) 105 for storing data to be sent to a host device, and a control device 106 for controlling the writing of data to, and the reading of data from, the data storage device 105.

The control device 106 comprises: an address registration unit 104, in which the host address of each host device has been registered for authorizing access, a command interpretation and execution unit 102 which on receipt of a command from a host device via the host device interface outputs the host address of the host device based on the command, and an address verification unit 103 for verifying the host address output from the command interpretation and execution unit 102 against the host address registered in the address reg-

istration unit 104, and for determining whether or not the particular host device has access authorization.

The command interpretation and execution unit 102 incorporates an authorization pending function, so that on receipt of a command from a host device, the command is interpreted and executed only after access is authorized by the address verification unit 103.

The command interpretation and execution unit 102 first receives a command from a host device, extracts the host address from the command and outputs it to the address verification unit 103. The address verification unit 103 reads the host addresses stored in the address registration unit 104 for the purpose of determining access authorization and verifies the host address sent from the command interpretation and execution unit 102. The access authorization information generated as a result of this verification process is then relayed back to the command interpretation and execution unit 102 by the address verification unit 103.

In those cases where access is authorized, the command interpretation and execution unit 102 sends the command received from the host device to the data storage unit 105, and the disk apparatus command, such as a data read/write command, is carried out in the same manner as for conventional disks.

The technique for determining access authorization could for example involve the registration of the host addresses of those host devices for which access is authorized in the address registration unit 104 and comparison of these address with the host address extracted from each command, with authorization being given in the case of a matching address. Alternatively, the host addresses of those host devices for which access is not authorized could be registered in the address registration unit 104, and authorization given if the host address extracted from the command did not match any of the registered addresses.

With the above example it was assumed that the host address was imbedded in the command, but in practice, the host address can sometimes be identified in exchanges prior to, or after the command. An example is presented in way of an explanation below.

For example in the case of a SCSI, the bus phase can be roughly divided up as shown in Figure 2. With a SCSI generally the host device interface is the initiator and the disk apparatus interface the target. When sending a command to the disk apparatus, the host device interface, the initiator, secures the bus in the arbitration phase, selects the disk apparatus in the selection phase, and then enters the information transfer phase for sending the command or data.

Within this series of phases, the initiator outputs its own ID and the ID of the target it is aiming to select in the selection phase. The specified disk apparatus, namely the target, on confirming it has been selected corresponds by switching the bus BSY signal to "true". At this point, the target samples the data bus and identifies the ID of the initiator.

In this way, the disk apparatus is able to ascertain the SCSI ID, namely the host address, of the other device. Further details are given in "Open design No. 1" (Published by CQ, 1994), pages 4 to 19.

In the case of a Fibre Channel, because communication is serial, the host address is recorded within the frame and so once again the disk apparatus is able to ascertain the host address of the other device.

Furthermore nowadays, in addition to those mentioned above, there are other protocols (such as IP (Internet Protocol)) which although not widely used as disk interfaces, do include a host address which becomes the transmission source.

An example configuration of the above embodiment which uses a general purpose CPU (central processing unit) is shown in Figure 3. A disk apparatus 101 comprises a CPU 106 which performs the centralized function of controlling reading and writing. The CPU 106 is connected to various circuit devices via a bus 107. Of these devices, a ROM (read only memory) 108 is memory solely for reading, and stores various programs and fixed data.

A RAM (random access memory) 109 is memory which is used, as required, for temporarily storing data during execution of a program.

A non volatile memory 110 is memory which can be written to by the CPU, and the content of which is saved when the power is turned off. A disk interface 111 is an interface for exchanging data and commands between the CPU and a data storage unit 105 which will be either a disk or some other storage medium.

A host device interface 112 is an interface for exchanging commands and data from a host device with the disk apparatus 101. In the case of a disk array, a SCSI is used for both the host device interface 112 and for the disk interface 111, but generally it is acceptable for the host device interface 112 and the disk interface 111 to be of different types.

For example, a Fibre Channel could be used for the host device interface 112 and a SCSI used for the disk interface 111. In small apparatus the disk storage medium itself is used as the data storage unit 105, but in large apparatus such as disk arrays the disk drive itself can be used as the data storage unit 105.

Next is a description of the use of the hardware resources shown in Figure 3 to bring to realization the function blocks of Figure 1. The command interpretation and execution unit 102 of Figure 1 is configured using the CPU 106, the bus 107, the ROM 108, the RAM 109, the disk interface 111 and the host device interface 112 of Figure 3. Similarly, the address verification unit 103 is configured using the CPU 106, the bus 107, the ROM 108, and the RAM 109.

The address registration unit 104 can be configured using the non volatile memory 110. Moreover, a read/write capable disk drive can be used as the data storage unit 105. In those instances where a disk drive with a SCSI interface is used as the data storage unit,

the commands which can be sent from the command interpretation and execution unit 102 to the data storage unit 105 are not limited to just read and write commands for data, but can also indicate commands in general retained by the SCSI interface. Furthermore, the disk drive can comprise any form which allows data storage, and can therefore be configured from memory with a power backup function or from non volatile memory.

Next is a description of the operation of a disk apparatus configured as shown in Figure 3. First, host addresses are stored in advance in the non volatile memory 110. The stored host addresses can be rewritten by the CPU 106, but will not be erased when the power is switched off. Consequently, when power is supplied to the disk apparatus 101, the host addresses which have been previously stored are able to be read out.

The command interpretation and execution unit 102 of Figure 1 receives commands from the host devices at the host device interface 112 and stores them temporarily in the RAM 109. The CPU 106 uses the programs stored in the ROM 108 for interpreting a command from a host device and extracting the host address. The thus extracted host address is then verified against the host addresses stored in the non volatile memory 110 by the CPU 106. In the method where the host addresses for those devices which are authorized for access are stored in the non volatile memory 110, access is authorized when the host address extracted from the command from the host device matches one of the host addresses stored in advance in the non volatile memory.

In those cases where access is authorized, the CPU 106 sends a command to the disk interface 111 in order to execute the command from the host device, which had been temporarily stored in the RAM 109. The disk interface 111 executes the command by sending it to the data storage unit 105. In those cases where information needs to be relayed to the host device as a result of the command being executed, the disk interface informs the CPU 106 that it has received a result.

On receiving this notification the CPU 106 receives the result from the disk interface 111, stores it temporarily in the RAM 109, and then transfers the result to the host device interface. In this way, commands from a host device are first judged as to whether access is possible, and then following execution, any result of the execution is returned to the host device.

With the above example, the host address stored temporarily in the RAM 109 and the access authorization determining host addresses stored in the non volatile memory 110 were compared, but in some cases the reading of non volatile memory is time consuming, and so it is possible to imagine a technique where on startup of the disk apparatus the access authorization determining host addresses stored in the non volatile memory 110 are transferred to the RAM 109.

Furthermore as with the invention of the first appa-

ratus, it is possible to imagine a technique where on startup of the disk apparatus the access authorization determining host addresses are transferred from the host device which controls the disk, and then stored in the RAM 109. With this technique, the amount of non volatile memory 110 can be greatly reduced.

Second embodiment

A block diagram showing the configuration of a disk apparatus according to a second embodiment of the present invention is shown in Figure 4. This is an embodiment which allows the setting of the host address afterwards. This embodiment will be explained in terms of the login operation from a host device to obtain authorization for using the disk apparatus, and the normal access operation.

First, in the login operation, the host information sent from a host device is used to determine whether that particular host device should be authorized. A disk apparatus 113 of this embodiment comprises a command interpretation and execution unit 114 for interpreting and executing commands from host devices. The command interpretation and execution unit 114 receives a command from a host device and extracts the necessary host information required to authorize usage of the disk apparatus as well as the host address accompanying that host information, and sends it all to a host check unit 115.

In the host check unit 115, this information is verified against access authorization determining host information which has been stored in advance in a host information storage unit 116. Examples of host information include the host device name, and a password. In those cases where the comparison results in a match, the host address sent from the command interpretation and execution unit 114 is registered in an address registration unit 118 as an access authorization determining address.

Once the host address has been registered in the address registration unit 118 in this way, the remaining operation is the same as for the first embodiment. Upon receiving a command from a host device the command interpretation and execution unit 114 extracts the host address from the command. It then sends this address to an address verification unit 117 and the address verification unit 117 verifies the address against the access authorization determining host addresses stored in the address registration unit 118 and then relays an access authorized or access denied message back to the command interpretation and execution unit 114. In the case where access is authorized, the command interpretation and execution unit 114 sends a command to the data storage unit 105 in order to execute the command.

With the second embodiment, the actual circuit configuration could take the form shown in Figure 3, as was the case with the first embodiment. The command interpretation and execution unit 114 of Figure 4 could

then be configured comprising the CPU 106, the bus 107, the ROM 108, the RAM 109, the disk interface 111, and the host device interface 112 of Figure 3. Similarly, the host check unit 115 and the address verification unit 117 can be configured comprising the CPU 106, the bus 107, the ROM 108, and the RAM 109. Furthermore, the host information unit 116 and the address registration unit 104 can be configured using the non volatile memory 110.

Third embodiment

A block diagram showing the configuration of a disk apparatus according to a third embodiment of the present invention is shown in Figure 5. A disk apparatus 119 of this embodiment comprises a command interpretation and execution unit 120 for interpreting and executing commands from a host device. The command interpretation and execution unit 120 extracts a host address from any disk read/write command sent from a host device and outputs it to an address offset information conversion unit 121, and also outputs a disk partition address extracted from the read/write command to an actual partition address conversion unit 122.

The technique used by the command interpretation and execution unit 120 for extracting a host address is as was outlined for the first embodiment. The host address output from the command interpretation and execution unit 120 is input into the address offset information conversion unit 121. Offset information which indicates a disk partition corresponding to each host device, has been stored in advance in the address offset information conversion unit 121, and the host address input from the command interpretation and execution unit 120 is converted to this offset information.

The actual partition address conversion unit 122 combines the disk partition address output from the command interpretation and execution unit 120 with the offset information output from the address offset information conversion unit 121, and generates an actual disk partition address which it then outputs to the command interpretation and execution unit 120. The command interpretation and execution unit 120 outputs a read/write command to the data storage unit 105 based on the actual disk partition address. The data storage unit 105 executes the command output from the actual partition address conversion unit 122 by, for example, reading out data to the host device, or receiving and storing data from the host device.

The present invention is configured and functions in the manner outlined above, with the invention of the first apparatus enabling the provision of a highly secure and advanced disk apparatus of a type not currently available, wherein determination of access authorization for a host device is based on the host address imbedded in the command sent from that particular host device, thus enabling commands to be accepted only from specified

host devices.

With the invention of the second apparatus, the information registered in advance in the disk apparatus by the user is not host addresses, but rather host information. Each host address is registered prior to that host device using the disk apparatus, so that once registered, subsequent recognition of the host device can be based on the host address imbedded in normal commands. Therefore procedures can be vastly simplified in comparison with the technique where host information is exchanged each time the disk apparatus is accessed. Furthermore, because the information registered in advance in the disk apparatus does not include host addresses, even if the interface configuration or address is changed there is little effect, allowing high security to be maintained.

With the invention of the third apparatus, following disk startup the host addresses relating to access authorization are received from the host device which controls the disk apparatus, and stored internally. This offers the advantage that complicated programming relating to host address registration does not need to be provided on the disk.

With the invention of the fourth apparatus, the disk apparatus is able to identify a host device from the host address imbedded within the command sent from the host device. Moreover because a partition offset information value is stored for each host device, the disk apparatus is able to allocate a different disk partition to each host device. Consequently, a single disk apparatus can essentially appear as a different disk to each host device, enabling the efficient usage of modern large volume disk apparatus.

Claims

1. A disk apparatus comprising, a host device interface (112) for sending and receiving data to and from a plurality of host devices, data storage means (105) for storing data to be sent to said host devices, and control means (106) for controlling the writing of data to, and the reading of data from, said data storage means (105), characterized in that said control device (106) comprises: an address registration unit (104; 118), in which the host address of each host device has been registered in advance, for the purpose of authorizing access, a command interpretation and execution unit (102; 114; 120) which on receipt of a command from a host device via said host device interface (112) outputs the host address of said host device based on said command, and an address verification unit (103) for verifying the host address output from said command interpretation and execution unit (102; 114) against the host address registered in said address registration unit (104; 118), and for determining whether or not the particular host device has access authorization, and said command interpre-

tation and execution unit (102; 114; 120) incorporates an authorization pending function, so that on receipt of a command from a host device, the command is interpreted and executed only after access is authorized by said address verification unit (103). 5

2. A disk apparatus according to claim 1, wherein a host information storage unit (116) in which information about the hosts such as host names and passwords is stored, is incorporated into said address registration unit (104; 118), and a host check unit (115) which, on receipt of host information from a host, determines whether or not that particular host has access authorization based on the host information received from the host and the host information stored in said host information storage unit (116), is incorporated into said command interpretation and execution unit (102; 114; 120), and said host check unit (115) incorporates an address registration function which registers the access authorization based on the host information, and the host address determined for the host device, in said address registration unit (104; 118). 10
3. A disk apparatus according to claim 2, wherein said host check unit (115) incorporates a startup setting function which requests host information from a plurality of host devices when said control means (106) is activated. 15
4. A disk apparatus according to claim 2, wherein said control means (106) comprises: an offset information generation unit (121), which on the basis of a host address output from said command interpretation and execution unit (102; 114; 120) generates offset information for the disk partition for that particular host device, and an actual partition address generation unit (122) which on the basis of the address for reading and writing to the disk apparatus, and the offset information, generates an actual disk partition address and then outputs that actual partition address to said command interpretation and execution unit (102; 114; 120). 20
5. A disk apparatus according to claim 1, wherein said command interpretation and execution unit (102; 114; 120) extracts said host address from said command received from said host device. 25

30

35

40

45

50

55

7

FIG.1

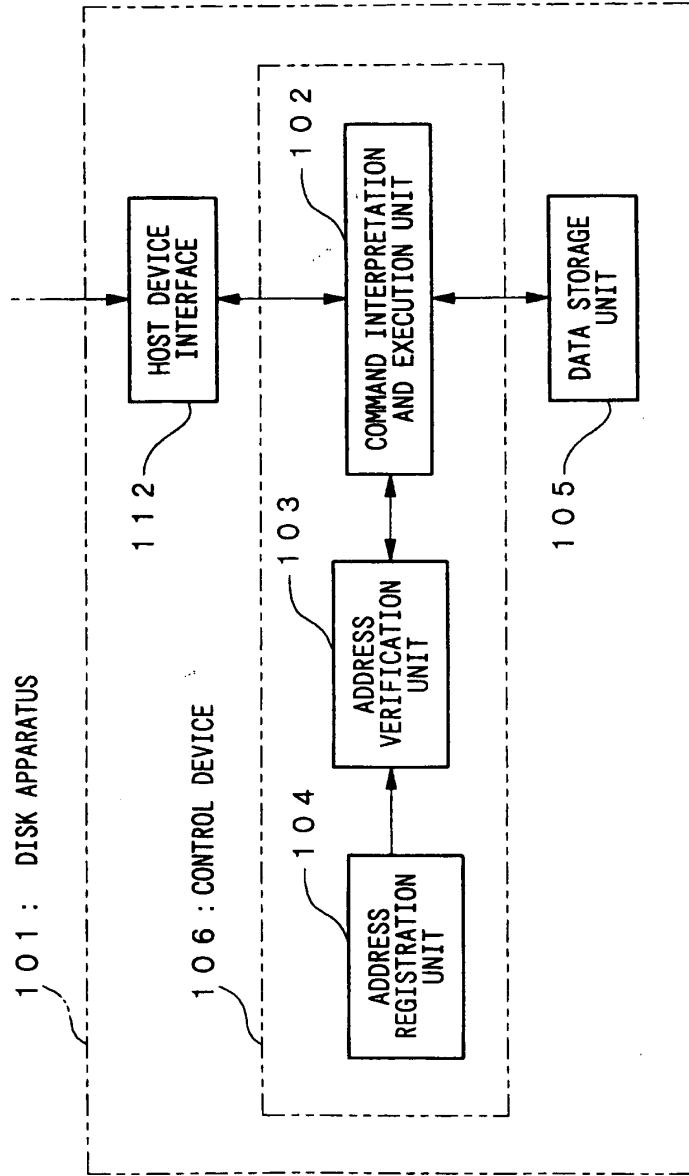

FIG.2

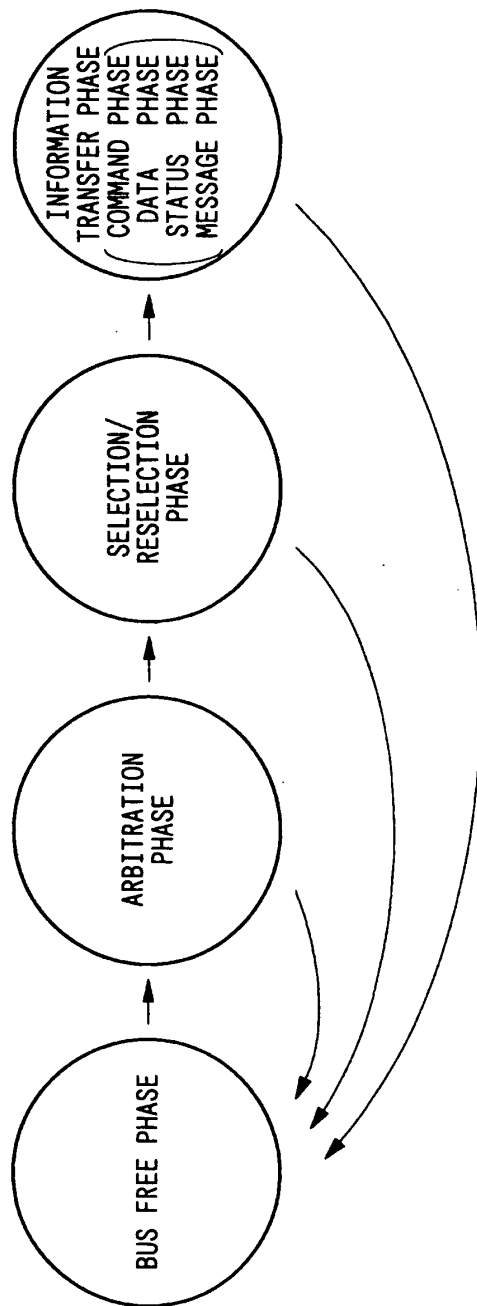

FIG.3

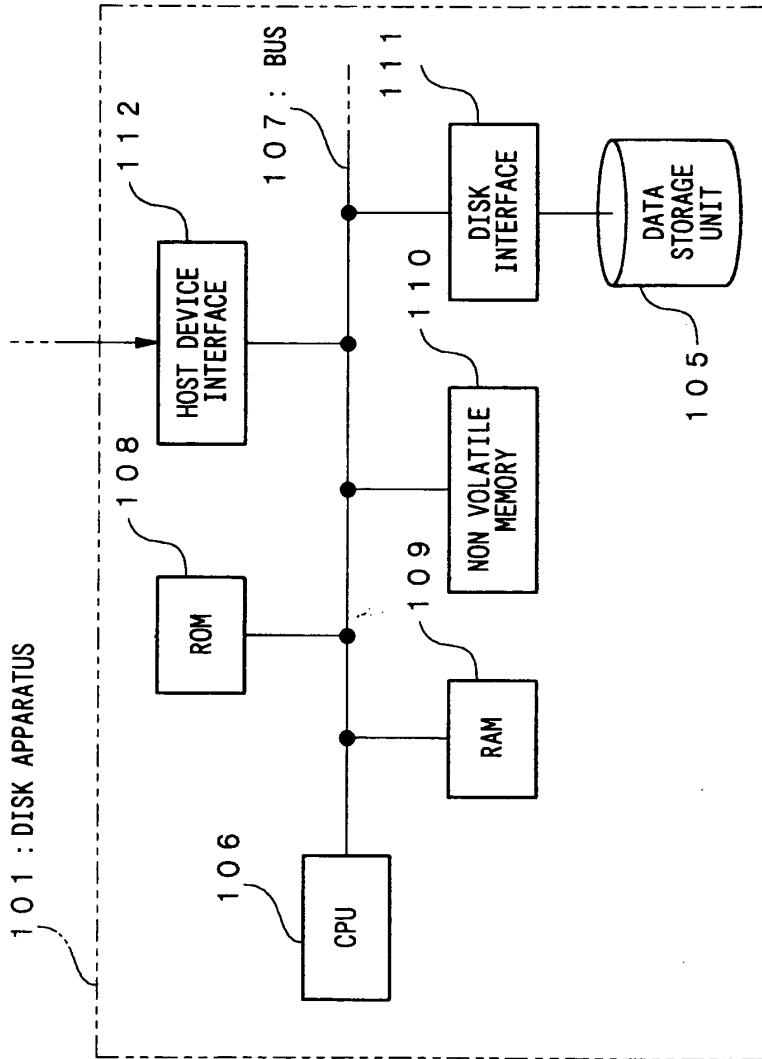

FIG.4

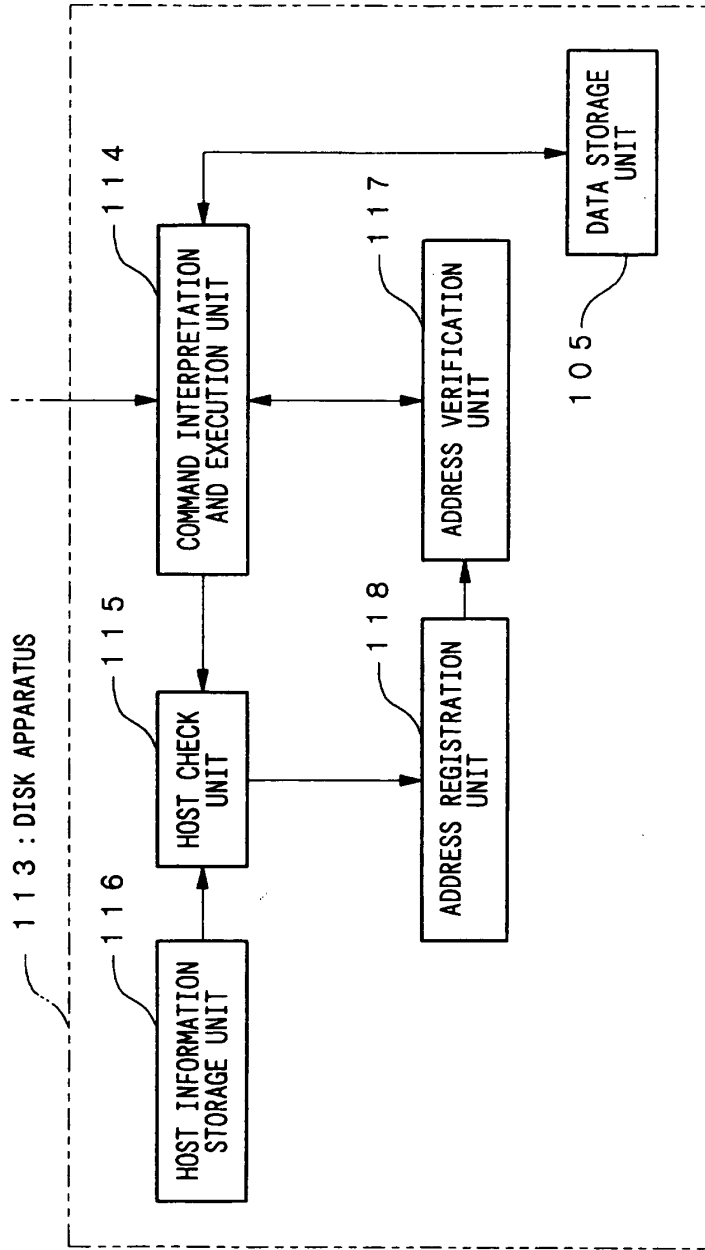

FIG.5

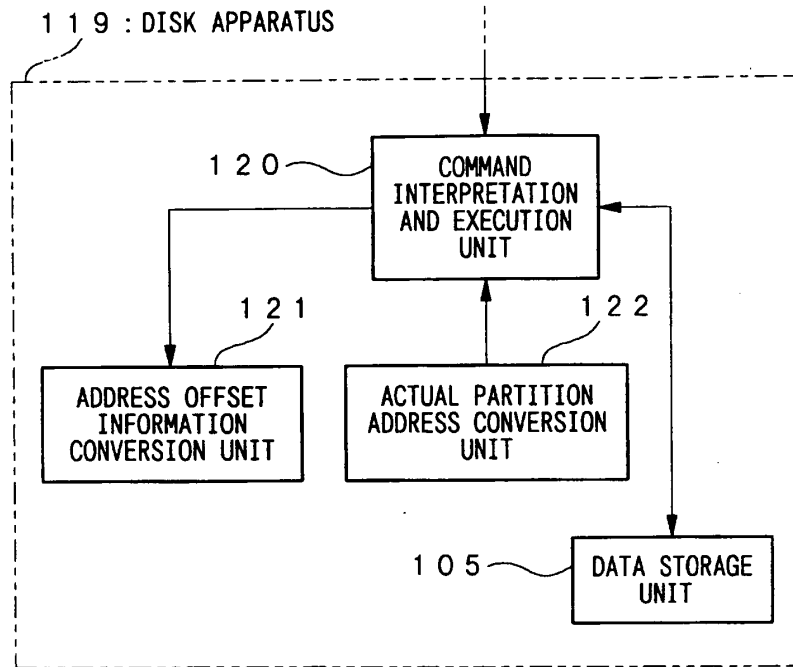
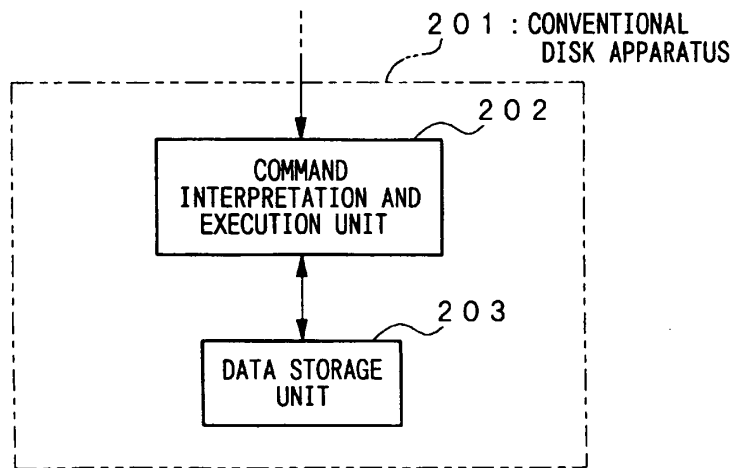

FIG.6



This Page Is Inserted by IFW Operations
and is not a part of the Official Record

BEST AVAILABLE IMAGES

Defective images within this document are accurate representations of the original documents submitted by the applicant.

Defects in the images may include (but are not limited to):

- BLACK BORDERS
- TEXT CUT OFF AT TOP, BOTTOM OR SIDES
- FADED TEXT
- ILLEGIBLE TEXT
- SKEWED/SLANTED IMAGES
- COLORED PHOTOS
- BLACK OR VERY BLACK AND WHITE DARK PHOTOS
- GRAY SCALE DOCUMENTS

IMAGES ARE BEST AVAILABLE COPY.

**As rescanning documents *will not* correct images,
please do not report the images to the
Image Problem Mailbox.**

(19) 日本国特許庁 (J P)

(12) 公開特許公報 (A)

(11) 特許出願公開番号

特開平8-230895

(43) 公開日 平成8年(1996)9月10日

(51) Int.Cl. ⁶	識別記号	庁内整理番号	F I	技術表示箇所
B 6 5 D	30/10		B 6 5 D	B
	81/20		81/20	B

審査請求 有 請求項の数 3 O L (全 3 頁)

(21) 出願番号 特願平7-39844

(22) 出願日 平成7年(1995)2月28日

(71) 出願人 595029554

樋口 秀一

新潟県三島郡与板町大字本与板3504番地

(72) 発明者 樋口 秀一

新潟県三島郡与板町大字本与板3504番地

(74) 代理人 弁理士 吉井 昭榮 (外 2 名)

(54) 【発明の名称】 穀類貯蔵用の袋体

(57) 【要約】

【目的】 本発明は米の長期貯蔵を簡単に行い得る穀類貯蔵用の袋体を提供することを目的とする。

【構成】 米、麦、大豆等の穀類を貯蔵する穀類貯蔵用の袋体であって、一側に開口部 1 a を形成した袋体 1 を設け、該開口部 1 a を適宜な手段により密封可能に構成し、公知の掃除機 2 により内部の空気を吸引する吸引部 3 を該袋体 1 に設けたものである。

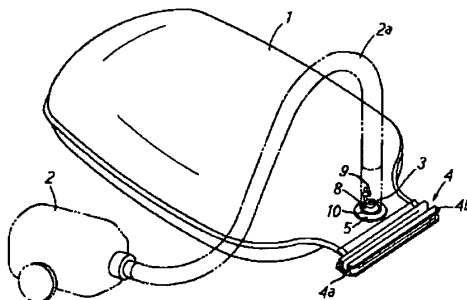

【特許請求の範囲】

【請求項1】 米、麦、大豆等の穀類を貯蔵する穀類貯蔵用の袋体であって、一側に開口部を形成した袋体を設け、該開口部を適宜な手段により密封可能に構成し、公知の掃除機により内部の空気を吸引する吸引部を該袋体に設けたことを特徴とする穀類貯蔵用の袋体。

【請求項2】 請求項1記載の穀類貯蔵用の袋体において、袋体の開口部を基部に対して巾細に形成したことを特徴とする穀類貯蔵用の袋体。

【請求項3】 請求項1、2いずれか1項に記載の穀類貯蔵用の袋体において、袋体の開口部を挟持する挟持体を設けたことを特徴とする穀類貯蔵用の袋体。

【発明の詳細な説明】

【0001】

【産業上の利用分野】本発明は、米、麦、大豆等の穀類を長期間貯蔵するに便利な穀類貯蔵用の袋体に関するものである。

【0002】

【従来の技術及び発明が解決しようとする課題】従来、米、麦、大豆等の穀類を長期間貯蔵する袋体として、袋体内に脱酸素剤を配設する穀類貯蔵専用の袋体（以下、従来例）が提案されている。

【0003】この従来例は、袋体の下方に透明なフィルムを貼着して内部が視認できる窓部を形成し、この袋体の中に米等の穀類を収納したら脱酸素剤を当該窓部位置に配設し、脱酸素剤の変色（酸素を吸着すると変色する。）を視認しながら米等を長期間貯蔵するものである。

【0004】しかしながら、脱酸素剤は酸素の吸着作用が所定期間しか発揮されず、よって、当該従来例の場合、適宜脱酸素剤を交換しなければならない。

【0005】ところで、この脱酸素剤の交換には当然袋体の開け閉めが伴うことになるが、この袋体の開け閉めにより酸素が少なくなっている袋体内に再び酸素が流入し、従って、また、一から酸素の吸着除去をしなければならず、結局、この穀物貯蔵専用の袋体は無駄が多く、非効率的である。

【0006】本発明は問題を解決した穀類貯蔵用の袋体を提供するものである。

【0007】

【課題を解決するための手段】添付図面を参照して本発明の要旨を説明する。

【0008】米、麦、大豆等の穀類を貯蔵する穀類貯蔵用の袋体であって、一側に開口部1aを形成した袋体1を設け、該開口部1aを適宜な手段により密封可能に構成し、公知の掃除機2により内部の空気を吸引する吸引部3を該袋体1に設けたことを特徴とする穀類貯蔵用の袋体に係るものである。

【0009】請求項1記載の穀類貯蔵用の袋体において、袋体1の開口部1aを基部に対して巾細に形成した

ことを特徴とする穀類貯蔵用の袋体に係るものである。

【0010】請求項1、2いずれか1項に記載の穀類貯蔵用の袋体において、袋体1の開口部1aを挟持する挟持体4を設けたことを特徴とする穀類貯蔵用の袋体に係るものである。

【0011】

【作用】袋体1に米等の穀類を収納し、開口部1aを適宜な手段で密封し、吸引部3に公知の掃除機2を連結して袋体1内の空気を吸引する。

【0012】

【実施例】図面は本発明の一実施例を図示したもので、以下に説明する。

【0013】本実施例の袋体1は適度に強度を有する透明な合成樹脂部材で成形する。該袋体1の上部は先細り状に形成され、この先細り部の端部が開口部1aに設定される。

【0014】この開口部1aは適宜な合成樹脂で成形した挟持凹体4aと挟持凸体4bからなる公知の挟持体4により挟持する。具体的には挟持凹体4aの凹条に挟持凸体4bの凸条を嵌入して両者により開口部1aを閉塞する。

【0015】袋体1の上端側には吸引部3が形成されている。この吸引部3は袋体1に付設される合成樹脂製の止着体8に突設されている。この止着体8は袋体1に穿設された窓孔位置に止着されるものであって、止着体8の外周に繞設した止着板5で窓孔周縁を挟持して袋体1に止着される。符号6は弁、7は米等が吸引されることを防止するフィルター、9は栓、10は掃除機2の吸引ホース2aを隙間なく可及的に密着状態にする為の柔軟板である。

【0016】本実施例は上述のように構成したから、袋体1内に例えば米を収納し、該袋体1の開口部1aを挟持体4で挟持して袋体1を密封する（開口部1aは折り返して挟持する。）この密封された状態で袋体1の吸引部3に掃除機2の吸引ホース2aを被嵌してその下端を柔軟板10に当接せしめ、掃除機2を動作させて袋体1内の空気を吸引すると、袋体1内は排気され可及的に真空状態となる。

【0017】よって、米を長期間貯蔵する場合には適宜掃除機2で袋体1内を排気するという簡単な作業で済むことになる。

【0018】また、本実施例の吸引部3は弁6が設けられている為、袋体1内の真空状態が不良となって再吸引する際、栓9を開放しても袋体1内に空気が流入することは確実に防止され、前記した従来例に比し効率的に米の貯蔵を行い得ることになる。

【0019】更に、本実施例は酸素のみを消失させる従来例とは異なり、空気を消失させ、真空状態を作出するものであるから、袋体1の容積が減少し、それだけ袋体1の保管スペースが少なくて済むことになるとともに袋

3
体1内の水分も除去され、この点においても米の良好な長期貯蔵が可能となる。

【0020】

【発明の効果】本発明は上述のように構成したから、米等の穀類の長期貯蔵を且つ良好簡単に行い得る秀れた穀類貯蔵用の袋体となる。

【図面の簡単な説明】

【図1】本実施例の斜視図である。

4
*【図2】本実施例の要部の断面図である。

【図3】本実施例の使用状態を示す斜視図である。

【符号の説明】

- 1 袋体
- 1a 開口部
- 2 掃除機
- 3 吸引部
- 4 挟持体

【図1】

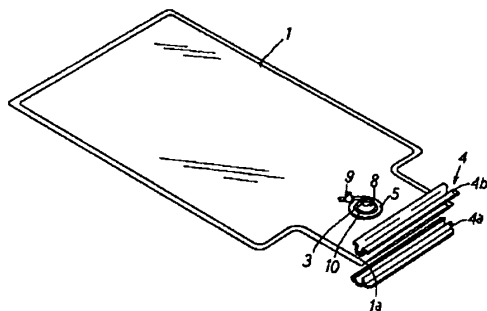

【図3】

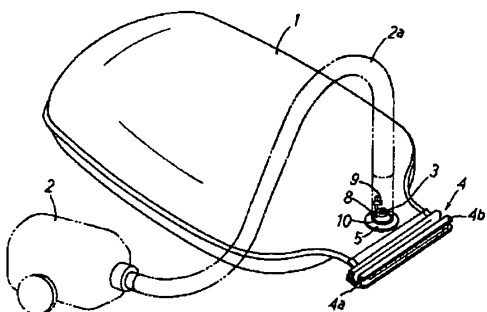

【図2】

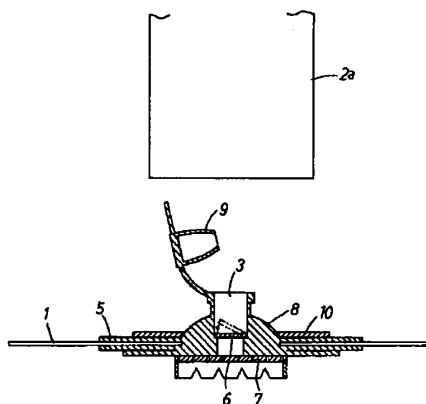

This Page Is Inserted by IFW Operations
and is not a part of the Official Record

BEST AVAILABLE IMAGES

Defective images within this document are accurate representations of the original documents submitted by the applicant.

Defects in the images may include (but are not limited to):

- BLACK BORDERS
- TEXT CUT OFF AT TOP, BOTTOM OR SIDES
- FADED TEXT
- ILLEGIBLE TEXT
- SKEWED/SLANTED IMAGES
- COLORED PHOTOS
- BLACK OR VERY BLACK AND WHITE DARK PHOTOS
- GRAY SCALE DOCUMENTS

IMAGES ARE BEST AVAILABLE COPY.

As rescanning documents *will not* correct images,
please do not report the images to the
Image Problem Mailbox.



INTERNATIONAL APPLICATION PUBLISHED UNDER THE PATENT COOPERATION TREATY (PCT)

<p>(51) International Patent Classification ⁶ : G06F 13/00</p>	<p>A1</p>	<p>(11) International Publication Number: WO 99/34297 (43) International Publication Date: 8 July 1999 (08.07.99)</p>
<p>(21) International Application Number: PCT/US98/27689 (22) International Filing Date: 28 December 1998 (28.12.98) (30) Priority Data: 09/001,799 31 December 1997 (31.12.97) US (71) Applicant: CROSSROADS SYSTEMS, INC. [US/US]; Suite II-300, 9390 Research Boulevard, Austin, TX 78759 (US). (72) Inventors: HOESE, Geoffrey, B.; 1904 Ann Arbor Avenue, Austin, TX 78704 (US). RUSSELL, Jeffry, T.; 205 Kariba Cove, Cibolo, TX 78108 (US). (74) Agent: HULSEY, William, R., III; Gray Cary Ware & Freidenrich LLP, Suite 1440, 100 Congress Avenue, Austin, TX 78701 (US).</p>		<p>(81) Designated States: CA, JP, European patent (AT, BE, CH, CY, DE, DK, ES, FI, FR, GB, GR, IE, IT, LU, MC, NL, PT, SE). Published With international search report.</p>

(54) Title: STORAGE ROUTER AND METHOD FOR PROVIDING VIRTUAL LOCAL STORAGE

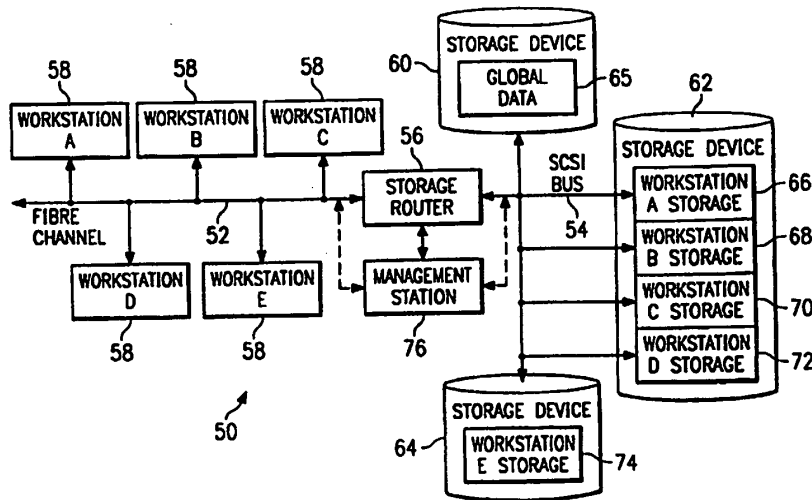

(57) Abstract

A storage router (56) and storage network (50) provide virtual local storage on remote SCSI storage devices (60, 62, 64) to Fibre Channel devices. A plurality of Fibre Channel devices, such as workstations (58), are connected to a Fibre Channel transport medium (52), and a plurality of SCSI storage devices (60, 62, 64) are connected to a SCSI bus transport medium (54). The storage router (56) interfaces between the Fibre Channel transport medium (52) and the SCSI bus transport medium (54). The storage router (56) maps between the workstations (58) and the SCSI storage devices (60, 62, 64) and implements access controls for storage space on the SCSI storage devices (60, 62, 64). The storage router (56) then allows access from the workstations (58) to the SCSI storage devices (60, 62, 64) using native low level, block protocol in accordance with the mapping and the access controls.

FOR THE PURPOSES OF INFORMATION ONLY

Codes used to identify States party to the PCT on the front pages of pamphlets publishing international applications under the PCT.

AL	Albania	ES	Spain	LS	Lesotho	SI	Slovenia
AM	Armenia	FI	Finland	LT	Lithuania	SK	Slovakia
AT	Austria	FR	France	LU	Luxembourg	SN	Senegal
AU	Australia	GA	Gabon	LV	Latvia	SZ	Swaziland
AZ	Azerbaijan	GB	United Kingdom	MC	Monaco	TD	Chad
BA	Bosnia and Herzegovina	GE	Georgia	MD	Republic of Moldova	TG	Togo
BB	Barbados	GH	Ghana	MG	Madagascar	TJ	Tajikistan
BE	Belgium	GN	Guinea	MK	The former Yugoslav Republic of Macedonia	TM	Turkmenistan
BF	Burkina Faso	GR	Greece			TR	Turkey
BG	Bulgaria	HU	Hungary	ML	Mali	TT	Trinidad and Tobago
BJ	Benin	IE	Ireland	MN	Mongolia	UA	Ukraine
BR	Brazil	IL	Israel	MR	Mauritania	UG	Uganda
BY	Belarus	IS	Iceland	MW	Malawi	US	United States of America
CA	Canada	IT	Italy	MX	Mexico	UZ	Uzbekistan
CF	Central African Republic	JP	Japan	NE	Niger	VN	Viet Nam
CG	Congo	KE	Kenya	NL	Netherlands	YU	Yugoslavia
CH	Switzerland	KG	Kyrgyzstan	NO	Norway	ZW	Zimbabwe
CI	Côte d'Ivoire	KP	Democratic People's Republic of Korea	NZ	New Zealand		
CM	Cameroon			PL	Poland		
CN	China	KR	Republic of Korea	PT	Portugal		
CU	Cuba	KZ	Kazakstan	RO	Romania		
CZ	Czech Republic	LC	Saint Lucia	RU	Russian Federation		
DE	Germany	LI	Liechtenstein	SD	Sudan		
DK	Denmark	LK	Sri Lanka	SE	Sweden		
EE	Estonia	LR	Liberia	SG	Singapore		

STORAGE ROUTER AND METHOD FOR PROVIDING VIRTUAL LOCAL
STORAGE

TECHNICAL FIELD OF THE INVENTION

This invention relates in general to network storage devices, and more particularly to a storage router and method for providing virtual local storage on remote SCSI storage devices to Fibre Channel devices

BACKGROUND OF THE INVENTION

Typical storage transport mediums provide for a relatively small number of devices to be attached over relatively short distances. One such transport medium is a Small Computer System Interface (SCSI) protocol, the structure and operation of which is generally well known as is described, for example, in the SCSI-1, SCSI-2 and SCSI-3 specifications. High speed serial interconnects provide enhanced capability to attach a large number of high speed devices to a common storage transport medium over large distances. One such serial interconnect is Fibre Channel, the structure and operation of which is described, for example, in *Fibre Channel Physical and Signaling Interface (FC-PH)*, ANSI X3.230 *Fibre Channel Arbitrated Loop (FC-AL)*, and ANSI X3.272 *Fibre Channel Private Loop Direct Attach (FC-PLDA)*.

Conventional computing devices, such as computer workstations, generally access storage locally or through network interconnects. Local storage typically consists of a disk drive, tape drive, CD-ROM drive or other storage device contained within, or locally connected to the workstation. The workstation provides a file system structure, that includes security controls, with access to the local storage device through native low level, block protocols. These protocols map directly to the mechanisms used by the storage device and consist of data requests without security controls. Network interconnects typically provide access for a large number of computing

devices to data storage on a remote network server. The remote network server provides file system structure, access control, and other miscellaneous capabilities that include the network interface. Access to data through
5 the network server is through network protocols that the server must translate into low level requests to the storage device. A workstation with access to the server storage must translate its file system protocols into network protocols that are used to communicate with the
10 server. Consequently, from the perspective of a workstation, or other computing device, seeking to access such server data, the access is much slower than access to data on a local storage device.

SUMMARY OF THE INVENTION

In accordance with the present invention, a storage router and method for providing virtual local storage on remote SCSI storage devices to Fibre Channel devices are disclosed that provide advantages over conventional network storage devices and methods.

According to one aspect of the present invention, a storage router and storage network provide virtual local storage on remote SCSI storage devices to Fibre Channel devices. A plurality of Fibre Channel devices, such as workstations, are connected to a Fibre Channel transport medium, and a plurality of SCSI storage devices are connected to a SCSI bus transport medium. The storage router interfaces between the Fibre Channel transport medium and the SCSI bus transport medium. The storage router maps between the workstations and the SCSI storage devices and implements access controls for storage space on the SCSI storage devices. The storage router then allows access from the workstations to the SCSI storage devices using native low level, block protocol in accordance with the mapping and the access controls.

According to another aspect of the present invention, virtual local storage on remote SCSI storage devices is provided to Fibre Channel devices. A Fibre Channel transport medium and a SCSI bus transport medium are interfaced with. A configuration is maintained for SCSI storage devices connected to the SCSI bus transport medium. The configuration maps between Fibre Channel

devices and the SCSI storage devices and implements access controls for storage space on the SCSI storage devices. Access is then allowed from Fibre Channel initiator devices to SCSI storage devices using native
5 low level, block protocol in accordance with the configuration.

A technical advantage of the present invention is the ability to centralize local storage for networked workstations without any cost of speed or overhead. Each
10 workstation access its virtual local storage as if it work locally connected. Further, the centralized storage devices can be located in a significantly remote position even in excess of ten kilometers as defined by Fibre Channel standards.

15 Another technical advantage of the present invention is the ability to centrally control and administer storage space for connected users without limiting the speed with which the users can access local data. In addition, global access to data, backups, virus scanning
20 and redundancy can be more easily accomplished by centrally located storage devices.

A further technical advantage of the present invention is providing support for SCSI storage devices as local storage for Fibre Channel hosts. In addition,
25 the present invention helps to provide extended capabilities for Fibre Channel and for management of storage subsystems.

BRIEF DESCRIPTION OF THE DRAWINGS

A more complete understanding of the present invention and the advantages thereof may be acquired by referring to the following description taken in
5 conjunction with the accompanying drawings, in which like reference numbers indicate like features, and wherein:

FIGURE 1 is a block diagram of a conventional network that provides storage through a network server;

10 FIGURE 2 is a block diagram of one embodiment of a storage network with a storage router that provides global access and routing;

FIGURE 3 is a block diagram of one embodiment of a storage network with a storage router that provides virtual local storage;

15 FIGURE 4 is a block diagram of one embodiment of the storage router of FIGURE 3; and

FIGURE 5 is a block diagram of one embodiment of data flow within the storage router of FIGURE 4.

DETAILED DESCRIPTION OF THE INVENTION

FIGURE 1 is a block diagram of a conventional network, indicated generally at 10, that provides access to storage through a network server. As shown, network 10 includes a plurality of workstations 12 interconnected with a network server 14 via a network transport medium 16. Each workstation 12 can generally comprise a processor, memory, input/output devices, storage devices and a network adapter as well as other common computer components. Network server 14 uses a SCSI bus 18 as a storage transport medium to interconnect with a plurality of storage devices 20 (tape drives, disk drives, etc.). In the embodiment of FIGURE 1, network transport medium 16 is an network connection and storage devices 20 comprise hard disk drives, although there are numerous alternate transport mediums and storage devices.

In network 10, each workstation 12 has access to its local storage device as well as network access to data on storage devices 20. The access to a local storage device is typically through native low level, block protocols. On the other hand, access by a workstation 12 to storage devices 20 requires the participation of network server 14 which implements a file system and transfers data to workstations 12 only through high level file system protocols. Only network server 14 communicates with storage devices 20 via native low level, block protocols. Consequently, the network access by workstations 12 through network server 14 is slow with respect to their

access to local storage. In network 10, it can also be a logistical problem to centrally manage and administer local data distributed across an organization, including accomplishing tasks such as backups, virus scanning and redundancy.

5

FIGURE 2 is a block diagram of one embodiment of a storage network, indicated generally at 30, with a storage router that provides global access and routing. This environment is significantly different from that of

10

FIGURE 1 in that there is no network server involved. In FIGURE 2, a Fibre Channel high speed serial transport 32 interconnects a plurality of workstations 36 and storage devices 38. A SCSI bus storage transport medium interconnects workstations 40 and storage devices 42. A

15

storage router 44 then serves to interconnect these mediums and provide devices on either medium global, transparent access to devices on the other medium. Storage router 44 routes requests from initiator devices on one medium to target devices on the other medium and

20

routes data between the target and the initiator. Storage router 44 can allow initiators and targets to be on either side. In this manner, storage router 44 enhances the functionality of Fibre Channel 32 by providing access, for example, to legacy SCSI storage

25

devices on SCSI bus 34. In the embodiment of FIGURE 2, the operation of storage router 44 can be managed by a management station 46 connected to the storage router via a direct serial connection.

In storage network 30, any workstation 36 or workstation 40 can access any storage device 38 or storage device 42 through native low level, block protocols, and vice versa. This functionality is enabled
5 by storage router 44 which routes requests and data as a generic transport between Fibre Channel 32 and SCSI bus 34. Storage router 44 uses tables to map devices from one medium to the other and distributes requests and data across Fibre Channel 32 and SCSI bus 34 without any
10 security access controls. Although this extension of the high speed serial interconnect provided by Fibre Channel 32 is beneficial, it is desirable to provide security controls in addition to extended access to storage devices through a native low level, block protocol.

15 FIGURE 3 is a block diagram of one embodiment of a storage network, indicated generally at 50, with a storage router that provides virtual local storage. Similar to that of FIGURE 2, storage network 50 includes a Fibre Channel high speed serial interconnect 52 and a
20 SCSI bus 54 bridged by a storage router 56. Storage router 56 of FIGURE 3 provides for a large number of workstations 58 to be interconnected on a common storage transport and to access common storage devices 60, 62 and 64 through native low level, block protocols.

25 According to the present invention, storage router 56 has enhanced functionality to implement security controls and routing such that each workstation 58 can have access to a specific subset of the overall data

stored in storage devices 60, 62 and 64. This specific subset of data has the appearance and characteristics of local storage and is referred to herein as virtual local storage. Storage router 56 allows the configuration and modification of the storage allocated to each attached workstation 58 through the use of mapping tables or other mapping techniques.

As shown in FIGURE 3, for example, storage device 60 can be configured to provide global data 65 which can be accessed by all workstations 58. Storage device 62 can be configured to provide partitioned subsets 66, 68, 70 and 72, where each partition is allocated to one of the workstations 58 (workstations A, B, C and D). These subsets 66, 68, 70 and 72 can only be accessed by the associated workstation 58 and appear to the associated workstation 58 as local storage accessed using native low level, block protocols. Similarly, storage device 64 can be allocated as storage for the remaining workstation 58 (workstation E).

Storage router 56 combines access control with routing such that each workstation 58 has controlled access to only the specified partition of storage device 62 which forms virtual local storage for the workstation 58. This access control allows security control for the specified data partitions. Storage router 56 allows this allocation of storage devices 60, 62 and 64 to be managed by a management station 76. Management station 76 can connect directly to storage router 56 via a direct

connection or, alternately, can interface with storage
router 56 through either Fibre Channel 52 or SCSI bus 54.
In the latter case, management station 76 can be a
workstation or other computing device with special rights
5 such that storage router 56 allows access to mapping
tables and shows storage devices 60, 62 and 64 as they
exist physically rather than as they have been allocated.

The environment of FIGURE 3 extends the concept of a
single workstation having locally connected storage
10 devices to a storage network 50 in which workstations 58
are provided virtual local storage in a manner
transparent to workstations 58. Storage router 56
provides centralized control of what each workstation 58
sees as its local drive, as well as what data it sees as
15 global data accessible by other workstations 58.
Consequently, the storage space considered by the
workstation 58 to be its local storage is actually a
partition (i.e., logical storage definition) of a
physically remote storage device 60, 62 or 64 connected
20 through storage router 56. This means that similar
requests from workstations 58 for access to their local
storage devices produce different accesses to the storage
space on storage devices 60, 62 and 64. Further, no
access from a workstation 58 is allowed to the virtual
25 local storage of another workstation 58.

The collective storage provided by storage devices
60, 62 and 64 can have blocks allocated by programming
means within storage router 56. To accomplish this

function, storage router 56 can include routing tables and security controls that define storage allocation for each workstation 58. The advantages provided by implementing virtual local storage in centralized storage devices include the ability to do collective backups and other collective administrative functions more easily. This is accomplished without limiting the performance of workstations 58 because storage access involves native low level, block protocols and does not involve the overhead of high level protocols and file systems required by network servers.

FIGURE 4 is a block diagram of one embodiment of storage router 56 of FIGURE 3. Storage router 56 can comprise a Fibre Channel controller 80 that interfaces with Fibre Channel 52 and a SCSI controller 82 that interfaces with SCSI bus 54. A buffer 84 provides memory work space and is connected to both Fibre Channel controller 80 and to SCSI controller 82. A supervisor unit 86 is connected to Fibre Channel controller 80, SCSI controller 82 and buffer 84. Supervisor unit 86 comprises a microprocessor for controlling operation of storage router 56 and to handle mapping and security access for requests between Fibre Channel 52 and SCSI bus 54.

FIGURE 5 is a block diagram of one embodiment of data flow within storage router 56 of FIGURE 4. As shown, data from Fibre Channel 52 is processed by a Fibre Channel (FC) protocol unit 88 and placed in a FIFO queue

90. A direct memory access (DMA) interface 92 then takes data out of FIFO queue 90 and places it in buffer 84. Supervisor unit 86 processes the data in buffer 84 as represented by supervisor processing 93. This processing
5 involves mapping between Fibre Channel 52 and SCSI bus 54 and applying access controls and routing functions. A DMA interface 94 then pulls data from buffer 84 and places it into a buffer 96. A SCSI protocol unit 98
10 pulls data from buffer 96 and communicates the data on SCSI bus 54. Data flow in the reverse direction, from SCSI bus 54 to Fibre Channel 52, is accomplished in a reverse manner.

The storage router of the present invention is a bridge device that connects a Fibre Channel link directly
15 to a SCSI bus and enables the exchange of SCSI command set information between application clients on SCSI bus devices and the Fibre Channel links. Further, the storage router applies access controls such that virtual
20 local storage can be established in remote SCSI storage devices for workstations on the Fibre Channel link. In one embodiment, the storage router provides a connection for Fibre Channel links running the SCSI Fibre Channel Protocol (FCP) to legacy SCSI devices attached to a SCSI
25 bus. The Fibre Channel topology is typically an Arbitrated Loop (FC_AL).

In part, the storage router enables a migration path to Fibre Channel based, serial SCSI networks by providing connectivity for legacy SCSI bus devices. The storage

router can be attached to a Fibre Channel Arbitrated Loop and a SCSI bus to support a number of SCSI devices. Using configuration settings, the storage router can make the SCSI bus devices available on the Fibre Channel
5 network as FCP logical units. Once the configuration is defined, operation of the storage router is transparent to application clients. In this manner, the storage router can form an integral part of the migration to new Fibre Channel based networks while providing a means to
10 continue using legacy SCSI devices.

In one implementation (not shown), the storage router can be a rack mount or free standing device with an internal power supply. The storage router can have a Fibre Channel and SCSI port, and a standard, detachable
15 power cord can be used, the FC connector can be a copper DB9 connector, and the SCSI connector can be a 68-pin type. Additional modular jacks can be provided for a serial port and a 802.3 10BaseT port, i.e. twisted pair Ethernet, for management access. The SCSI port of the
20 storage router can support SCSI direct and sequential access target devices and can support SCSI initiators, as well. The Fibre Channel port can interface to SCSI-3 FCP enabled devices and initiators.

To accomplish its functionality, one implementation
25 of the storage router uses: a Fibre Channel interface based on the HEWLETT-PACKARD TACHYON HPFC-5000 controller and a GLM media interface; an Intel 80960RP processor, incorporating independent data and program memory spaces,

and associated logic required to implement a stand alone processing system; and a serial port for debug and system configuration. Further, this implementation includes a SCSI interface supporting Fast-20 based on the SYMBIOS
5 53C8xx series SCSI controllers, and an operating system based upon the WIND RIVERS SYSTEMS VXWORKS or IXWORKS kernel, as determined by design. In addition, the storage router includes software as required to control basic functions of the various elements, and to provide
10 appropriate translations between the FC and SCSI protocols.

The storage router has various modes of operation that are possible between FC and SCSI target and initiator combinations. These modes are: FC Initiator to
15 SCSI Target; SCSI Initiator to FC Target; SCSI Initiator to SCSI Target; and FC Initiator to FC Target. The first two modes can be supported concurrently in a single storage router device are discussed briefly below. The third mode can involve two storage router devices
20 back to back and can serve primarily as a device to extend the physical distance beyond that possible via a direct SCSI connection. The last mode can be used to carry FC protocols encapsulated on other transmission technologies (e.g. ATM, SONET), or to act as a bridge
25 between two FC loops (e.g. as a two port fabric).

The FC Initiator to SCSI Target mode provides for the basic configuration of a server using Fibre Channel to communicate with SCSI targets. This mode requires

that a host system have an FC attached device and associated device drivers and software to generate SCSI-3 FCP requests. This system acts as an initiator using the storage router to communicate with SCSI target devices.

5 The SCSI devices supported can include SCSI-2 compliant direct or sequential access (disk or tape) devices. The storage router serves to translate command and status information and transfer data between SCSI-3 FCP and SCSI-2, allowing the use of standard SCSI-2 devices in a

10 Fibre Channel environment.

The SCSI Initiator to FC Target mode provides for the configuration of a server using SCSI-2 to communicate with Fibre Channel targets. This mode requires that a host system has a SCSI-2 interface and driver software to

15 control SCSI-2 target devices. The storage router will connect to the SCSI-2 bus and respond as a target to multiple target IDs. Configuration information is required to identify the target IDs to which the bridge will respond on the SCSI-2 bus. The storage router then

20 translates the SCSI-2 requests to SCSI-3 FCP requests, allowing the use of FC devices with a SCSI host system. This will also allow features such as a tape device acting as an initiator on the SCSI bus to provide full support for this type of SCSI device.

25 In general, user configuration of the storage router will be needed to support various functional modes of operation. Configuration can be modified, for example, through a serial port or through an Ethernet port via

SNMP (simple network management protocol) or a Telnet session. Specifically, SNMP manageability can be provided via an 802.3 Ethernet interface. This can provide for configuration changes as well as providing
5 statistics and error information. Configuration can also be performed via TELNET or RS-232 interfaces with menu driven command interfaces. Configuration information can be stored in a segment of flash memory and can be retained across resets and power off cycles. Password
10 protection can also be provided.

In the first two modes of operation, addressing information is needed to map from FC addressing to SCSI addressing and vice versa. This can be 'hard'
15 configuration data, due to the need for address information to be maintained across initialization and partial reconfigurations of the Fibre Channel address space. In an arbitrated loop configuration, user configured addresses will be needed for AL_PAs in order to insure that known addresses are provided between loop
20 reconfigurations.

With respect to addressing, FCP and SCSI 2 systems employ different methods of addressing target devices. Additionally, the inclusion of a storage router means that a method of translating device IDs needs to be
25 implemented. In addition, the storage router can respond to commands without passing the commands through to the opposite interface. This can be implemented to allow all generic FCP and SCSI commands to pass through the storage

router to address attached devices, but allow for configuration and diagnostics to be performed directly on the storage router through the FC and SCSI interfaces.

Management commands are those intended to be
5 processed by the storage router controller directly.
This may include diagnostic, mode, and log commands as well as other vendor-specific commands. These commands can be received and processed by both the FCP and SCSI interfaces, but are not typically bridged to the opposite
10 interface. These commands may also have side effects on the operation of the storage router, and cause other storage router operations to change or terminate.

A primary method of addressing management commands though the FCP and SCSI interfaces can be through
15 peripheral device type addressing. For example, the storage router can respond to all operations addressed to logical unit (LUN) zero as a controller device. Commands that the storage router will support can include INQUIRY as well as vendor-specific management commands. These
20 are to be generally consistent with SCC standard commands.

The SCSI bus is capable of establishing bus connections between targets. These targets may internally address logical units. Thus, the prioritized
25 addressing scheme used by SCSI subsystems can be represented as follows: BUS:TARGET:LOGICAL UNIT. The BUS identification is intrinsic in the configuration, as a SCSI initiator is attached to only one bus. Target

addressing is handled by bus arbitration from information provided to the arbitrating device. Target addresses are assigned to SCSI devices directly, though some means of configuration, such as a hardware jumper, switch setting, or device specific software configuration. As such, the SCSI protocol provides only logical unit addressing within the Identify message. Bus and target information is implied by the established connection.

Fibre Channel devices within a fabric are addressed by a unique port identifier. This identifier is assigned to a port during certain well-defined states of the FC protocol. Individual ports are allowed to arbitrate for a known, user defined address. If such an address is not provided, or if arbitration for a particular user address fails, the port is assigned a unique address by the FC protocol. This address is generally not guaranteed to be unique between instances. Various scenarios exist where the AL-PA of a device will change, either after power cycle or loop reconfiguration.

The FC protocol also provides a logical unit address field within command structures to provide addressing to devices internal to a port. The FCP_CMD payload specifies an eight byte LUN field. Subsequent identification of the exchange between devices is provided by the FQXID (Fully Qualified Exchange ID).

FC ports can be required to have specific addresses assigned. Although basic functionality is not dependent on this, changes in the loop configuration could result

in disk targets changing identifiers with the potential risk of data corruption or loss. This configuration can be straightforward, and can consist of providing the device a loop-unique ID (AL_PA) in the range of "01h" to "EFh." Storage routers could be shipped with a default value with the assumption that most configurations will be using single storage routers and no other devices requesting the present ID. This would provide a minimum amount of initial configuration to the system administrator. Alternately, storage routers could be defaulted to assume any address so that configurations requiring multiple storage routers on a loop would not require that the administrator assign a unique ID to the additional storage routers.

Address translation is needed where commands are issued in the cases FC Initiator to SCSI Target and SCSI Initiator to FC Target. Target responses are qualified by the FQXID and will retain the translation acquired at the beginning of the exchange. This prevents configuration changes occurring during the course of execution of a command from causing data or state information to be inadvertently misdirected. Configuration can be required in cases of SCSI Initiator to FC Target, as discovery may not effectively allow for FCP targets to consistently be found. This is due to an FC arbitrated loop supporting addressing of a larger number of devices than a SCSI bus and the possibility of FC devices changing their AL-PA due to device insertion

or other loop initialization.

In the direct method, the translation to
BUS:TARGET:LUN of the SCSI address information will be
direct. That is, the values represented in the FCP LUN
5 field will directly map to the values in effect on the
SCSI bus. This provides a clean translation and does not
require SCSI bus discovery. It also allows devices to be
dynamically added to the SCSI bus without modifying the
address map. It may not allow for complete discovery by
10 FCP initiator devices, as gaps between device addresses
may halt the discovery process. Legacy SCSI device
drivers typically halt discovery on a target device at
the first unoccupied LUN, and proceed to the next target.
This would lead to some devices not being discovered.
15 However, this allows for hot plugged devices and other
changes to the loop addressing.

In the ordered method, ordered translation requires
that the storage router perform discovery on reset, and
collapses the addresses on the SCSI bus to sequential FCP
20 LUN values. Thus, the FCP LUN values 0-N can represent
N+1 SCSI devices, regardless of SCSI address values, in
the order in which they are isolated during the SCSI
discovery process. This would allow the FCP initiator
discovery process to identify all mapped SCSI devices
25 without further configuration. This has the limitation
that hot-plugged devices will not be identified until the
next reset cycle. In this case, the address may also be
altered as well.

In addition to addressing, according to the present invention, the storage router provides configuration and access controls that cause certain requests from FC Initiators to be directed to assigned virtual local storage partitioned on SCSI storage devices. For example, the same request for LUN 0 (local storage) by two different FC Initiators can be directed to two separate subsets of storage. The storage router can use tables to map, for each initiator, what storage access is available and what partition is being addressed by a particular request. In this manner, the storage space provided by SCSI storage devices can be allocated to FC initiators to provide virtual local storage as well as to create any other desired configuration for secured access.

Although the present invention has been described in detail, it should be understood that various changes, substitutions, and alterations can be made hereto without departing from the spirit and scope of the invention as defined by the appended claims.

WHAT IS CLAIMED IS:

1. A storage router for providing virtual local storage on remote SCSI storage devices to Fibre Channel devices, comprising:

5 a buffer providing memory work space for the storage router;

a Fibre Channel controller operable to connect to and interface with a Fibre Channel transport medium;

10 a SCSI controller operable to connect to and interface with a SCSI bus transport medium; and

a supervisor unit coupled to the Fibre Channel controller, the SCSI controller and the buffer, the supervisor unit operable:

15 to maintain a configuration for SCSI storage devices connected to the SCSI bus transport medium that maps between Fibre Channel devices and SCSI storage devices and that implements access controls for storage space on the SCSI storage devices; and

20 to process data in the buffer to interface between the Fibre Channel controller and the SCSI controller to allow access from Fibre Channel initiator devices to SCSI storage devices using native low level, block protocol in accordance with the configuration.

2. The storage router of Claim 1, wherein the configuration maintained by the supervisor unit includes an allocation of subsets of storage space to associated Fibre Channel devices, wherein each subset is only
5 accessible by the associated Fibre Channel device.

3. The storage router of Claim 2, wherein the Fibre Channel devices comprise workstations.

10 4. The storage router of Claim 2, wherein the SCSI storage devices comprise hard disk drives.

5. The storage router of Claim 1, wherein the Fibre Channel controller comprises:
15 a Fibre Channel (FC) protocol unit operable to connect to the Fibre Channel transport medium;
a first-in-first-out queue coupled to the Fibre Channel protocol unit; and
a direct memory access (DMA) interface coupled to
20 the first-in-first-out queue and to the buffer.

6. The storage router of Claim 1, wherein the SCSI controller comprises:
a SCSI protocol unit operable to connect to the SCSI
25 bus transport medium;
an internal buffer coupled to the SCSI protocol unit; and
a direct memory access (DMA) interface coupled to

the internal buffer and to the buffer of the storage router.

- 5 7. A storage network, comprising:
a Fibre Channel transport medium;
a SCSI bus transport medium;
a plurality of workstations connected to the Fibre Channel transport medium;
a plurality of SCSI storage devices connected to the
10 SCSI bus transport medium; and
a storage router interfacing between the Fibre Channel transport medium and the SCSI bus transport medium, the storage router providing virtual local storage on the SCSI storage devices to the workstations
15 and operable:
to map between the workstations and the SCSI storage devices;
to implement access controls for storage space on the SCSI storage devices; and
20 to allow access from the workstations to the SCSI storage devices using native low level, block protocol in accordance with the mapping and access controls.

- 25 8. The storage network of Claim 7, wherein the access controls include an allocation of subsets of storage space to associated workstations, wherein each subset is only accessible by the associated workstation.

9. The storage network of Claim 7, wherein the SCSI storage devices comprise hard disk drives.

5 10. The storage network of Claim 7, wherein the storage router comprises:

a buffer providing memory work space for the storage router;

10 a Fibre Channel controller operable to connect to and interface with a Fibre Channel transport medium, the Fibre Channel controller further operable to pull outgoing data from the buffer and to place incoming data into the buffer;

15 a SCSI controller operable to connect to and interface with a SCSI bus transport medium, the SCSI controller further operable to pull outgoing data from the buffer and to place incoming data into the buffer; and

20 a supervisor unit coupled to the Fibre Channel controller, the SCSI controller and the buffer, the supervisor unit operable:

25 to maintain a configuration for the SCSI storage devices that maps between Fibre Channel devices and SCSI storage devices and that implements the access controls for storage space on the SCSI storage devices; and

to process data in the buffer to interface between the Fibre Channel controller and the SCSI

controller to allow access from workstations to SCSI storage devices in accordance with the configuration.

5 11. A method for providing virtual local storage on remote SCSI storage devices to Fibre Channel devices, comprising:

interfacing with a Fibre Channel transport medium;
interfacing with a SCSI bus transport medium;
maintaining a configuration for SCSI storage devices
10 connected to the SCSI bus transport medium that maps between Fibre Channel devices and the SCSI storage devices and that implements access controls for storage space on the SCSI storage devices; and

allowing access from Fibre Channel initiator devices
15 to SCSI storage devices using native low level, block protocol in accordance with the configuration.

12. The method of Claim 11, wherein maintaining the configuration includes allocating subsets of storage
20 space to associated Fibre Channel devices, wherein each subset is only accessible by the associated Fibre Channel device.

13. The method of Claim 12, wherein the Fibre
25 Channel devices comprise workstations.

14. The method of Claim 12, wherein the SCSI storage devices comprise hard disk drives.

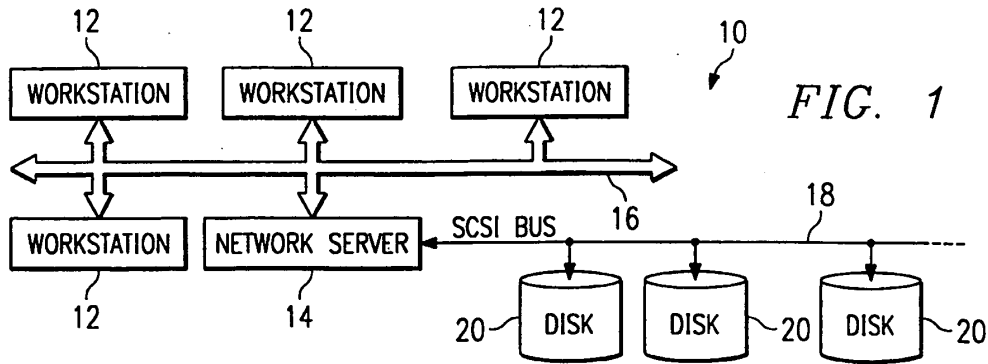

FIG. 1

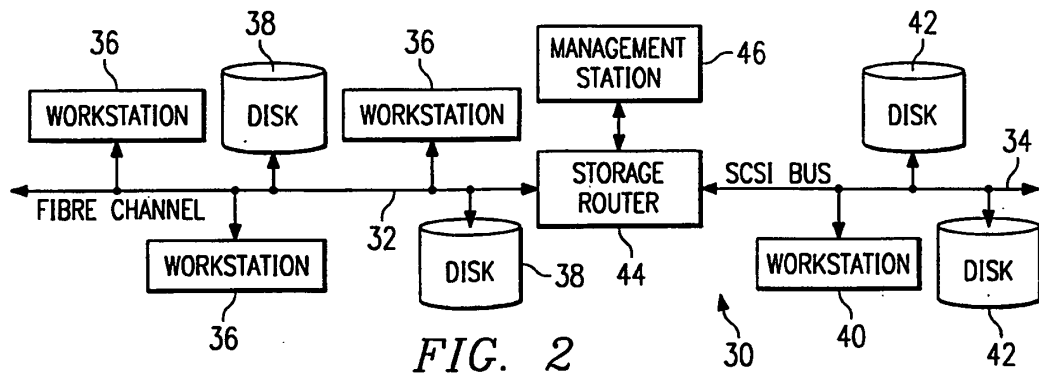

FIG. 2

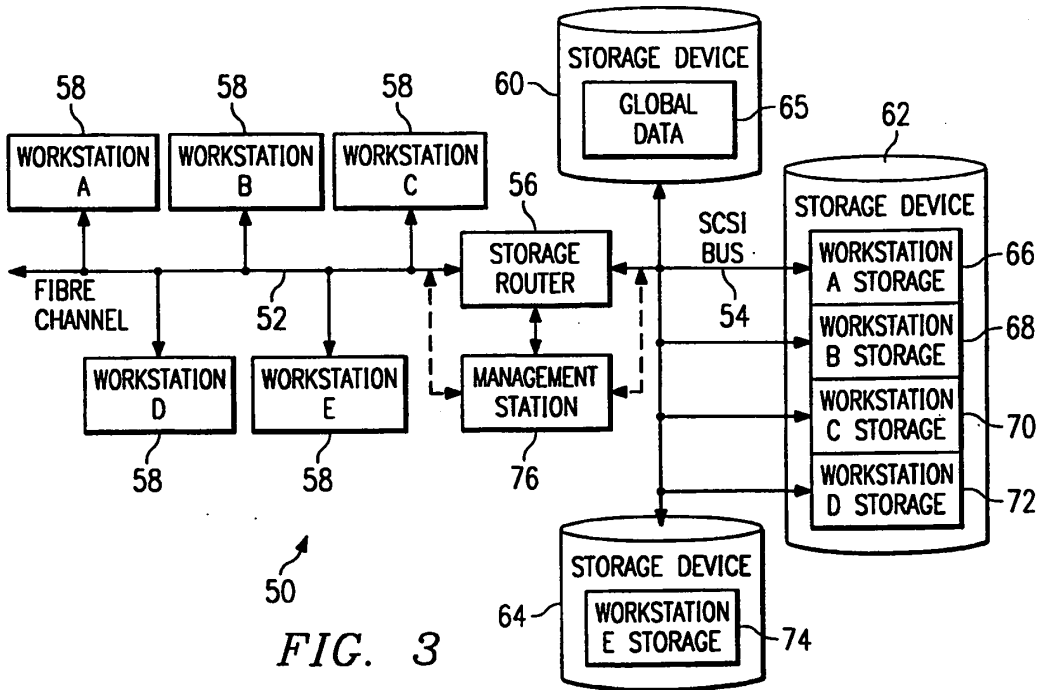
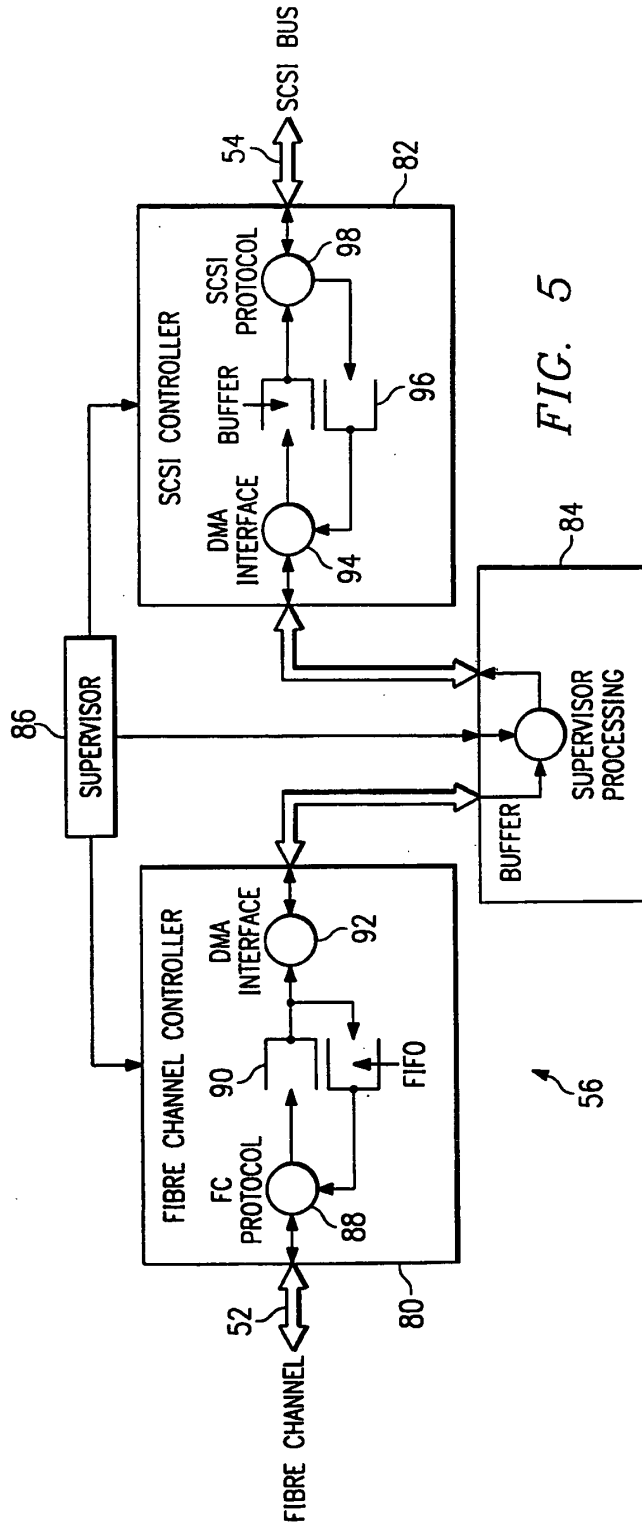
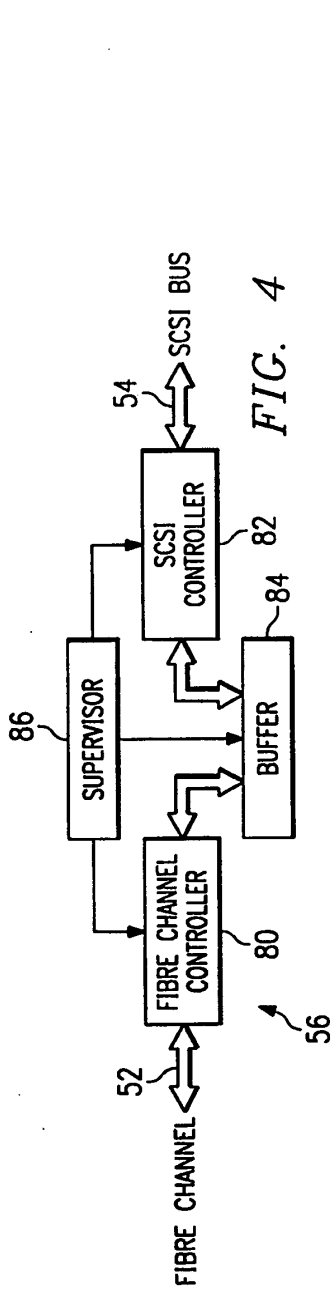

FIG. 3



INTERNATIONAL SEARCH REPORT

International application No.
PCT/US98/27689

<p>A. CLASSIFICATION OF SUBJECT MATTER IPC(6) : G06F 13/00 US CL : 710/129, 128, 2 According to International Patent Classification (IPC) or to both national classification and IPC</p>																				
<p>B. FIELDS SEARCHED Minimum documentation searched (classification system followed by classification symbols) U.S. : 710/129, 128, 2</p> <p>Documentation searched other than minimum documentation to the extent that such documents are included in the fields searched</p> <p>Electronic data base consulted during the international search (name of data base and, where practicable, search terms used) STN, APS, DIALOG</p>																				
<p>C. DOCUMENTS CONSIDERED TO BE RELEVANT</p> <table border="1"> <thead> <tr> <th>Category*</th> <th>Citation of document, with indication, where appropriate, of the relevant passages</th> <th>Relevant to claim No.</th> </tr> </thead> <tbody> <tr> <td>A</td> <td>US 5,748,924 A (LLORENS et al.) 05 May 1998, entire document</td> <td>1-14</td> </tr> <tr> <td>A</td> <td>US 5,835,496 A (YEUNG et al.) 10 November 1998, entire document</td> <td>1-14</td> </tr> <tr> <td>A</td> <td>US 5,768,623 A (JUDD et al.) 16 June 1998, entire document</td> <td>1-14</td> </tr> <tr> <td>A</td> <td>US 5,809,328 A (NOGALES et al.) 15 September 1998, entire document</td> <td>1-14</td> </tr> <tr> <td>A</td> <td>US 5,812,754 A (LUI et al.) 22 September 1998, entire document</td> <td>1-14</td> </tr> </tbody> </table>			Category*	Citation of document, with indication, where appropriate, of the relevant passages	Relevant to claim No.	A	US 5,748,924 A (LLORENS et al.) 05 May 1998, entire document	1-14	A	US 5,835,496 A (YEUNG et al.) 10 November 1998, entire document	1-14	A	US 5,768,623 A (JUDD et al.) 16 June 1998, entire document	1-14	A	US 5,809,328 A (NOGALES et al.) 15 September 1998, entire document	1-14	A	US 5,812,754 A (LUI et al.) 22 September 1998, entire document	1-14
Category*	Citation of document, with indication, where appropriate, of the relevant passages	Relevant to claim No.																		
A	US 5,748,924 A (LLORENS et al.) 05 May 1998, entire document	1-14																		
A	US 5,835,496 A (YEUNG et al.) 10 November 1998, entire document	1-14																		
A	US 5,768,623 A (JUDD et al.) 16 June 1998, entire document	1-14																		
A	US 5,809,328 A (NOGALES et al.) 15 September 1998, entire document	1-14																		
A	US 5,812,754 A (LUI et al.) 22 September 1998, entire document	1-14																		
<p><input type="checkbox"/> Further documents are listed in the continuation of Box C. <input type="checkbox"/> See patent family annex.</p>																				
<p>* Special categories of cited documents:</p> <table border="0"> <tr> <td>*A* document defining the general state of the art which is not considered to be of particular relevance</td> <td>*T* later document published after the international filing date or priority date and not in conflict with the application but cited to understand the principle or theory underlying the invention</td> </tr> <tr> <td>*E* earlier document published on or after the international filing date</td> <td>*X* document of particular relevance; the claimed invention cannot be considered novel or cannot be considered to involve an inventive step when the document is taken alone</td> </tr> <tr> <td>*L* document which may throw doubts on priority claim(s) or which is cited to establish the publication date of another citation or other special reason (as specified)</td> <td>*Y* document of particular relevance; the claimed invention cannot be considered to involve an inventive step when the document is combined with one or more other such documents, such combination being obvious to a person skilled in the art</td> </tr> <tr> <td>*O* document referring to an oral disclosure, use, exhibition or other means</td> <td>*G* document member of the same patent family</td> </tr> <tr> <td>*P* document published prior to the international filing date but later than the priority date claimed</td> <td></td> </tr> </table>			*A* document defining the general state of the art which is not considered to be of particular relevance	*T* later document published after the international filing date or priority date and not in conflict with the application but cited to understand the principle or theory underlying the invention	*E* earlier document published on or after the international filing date	*X* document of particular relevance; the claimed invention cannot be considered novel or cannot be considered to involve an inventive step when the document is taken alone	*L* document which may throw doubts on priority claim(s) or which is cited to establish the publication date of another citation or other special reason (as specified)	*Y* document of particular relevance; the claimed invention cannot be considered to involve an inventive step when the document is combined with one or more other such documents, such combination being obvious to a person skilled in the art	*O* document referring to an oral disclosure, use, exhibition or other means	*G* document member of the same patent family	*P* document published prior to the international filing date but later than the priority date claimed									
A document defining the general state of the art which is not considered to be of particular relevance	*T* later document published after the international filing date or priority date and not in conflict with the application but cited to understand the principle or theory underlying the invention																			
E earlier document published on or after the international filing date	*X* document of particular relevance; the claimed invention cannot be considered novel or cannot be considered to involve an inventive step when the document is taken alone																			
L document which may throw doubts on priority claim(s) or which is cited to establish the publication date of another citation or other special reason (as specified)	*Y* document of particular relevance; the claimed invention cannot be considered to involve an inventive step when the document is combined with one or more other such documents, such combination being obvious to a person skilled in the art																			
O document referring to an oral disclosure, use, exhibition or other means	*G* document member of the same patent family																			
P document published prior to the international filing date but later than the priority date claimed																				
Date of the actual completion of the international search 12 MARCH 1999		Date of mailing of the international search report 05 APR 1999																		
Name and mailing address of the ISA/US Commissioner of Patents and Trademarks Box PCT Washington, D.C. 20231 Facsimile No. (703) 305-3230		Authorized officer CHRISTOPHER SHIN <i>Christopher Shin</i> Telephone No. (703) 305-9600																		

This Page Is Inserted by IFW Operations
and is not a part of the Official Record

BEST AVAILABLE IMAGES

Defective images within this document are accurate representations of the original documents submitted by the applicant.

Defects in the images may include (but are not limited to):

- BLACK BORDERS
- TEXT CUT OFF AT TOP, BOTTOM OR SIDES
- FADED TEXT
- ILLEGIBLE TEXT
- SKEWED/SLANTED IMAGES
- COLORED PHOTOS
- BLACK OR VERY BLACK AND WHITE DARK PHOTOS
- GRAY SCALE DOCUMENTS

IMAGES ARE BEST AVAILABLE COPY.

**As rescanning documents *will not* correct images,
please do not report the images to the
Image Problem Mailbox.**



Europäisches Patentamt
 European Patent Office
 Office européen des brevets



(11) EP 0 810 530 A2

(12) **EUROPEAN PATENT APPLICATION**

(43) Date of publication:
 03.12.1997 Bulletin 1997/49

(51) Int. Cl.⁶: G06F 13/368

(21) Application number: 97107935.5

(22) Date of filing: 15.05.1997

(84) Designated Contracting States:
 DE FR GB NL SE

(30) Priority: 31.05.1996 US 656641

(71) Applicant:
 SUN MICROSYSTEMS, INC.
 Mountain View, CA 94043 (US)

(72) Inventors:
 • Schmahl, Kenneth A.
 San Jose, CA 95136 (US)
 • Tedone, Matthew J.
 Sunnyvale, CA 94087 (US)

• Schell, John C.
 Sunnyvale, CA 94087 (US)
 • Kaminsky, Igor
 San Jose, CA 95129 (US)
 • Chan, Ray P.
 Cupertino, CA 95014 (US)

(74) Representative:
 Zangs, Rainer E., Dipl.-Ing. et al
 Hoffmann Eitle,
 Patent- und Rechtsanwälte,
 Arabellastrasse 4
 81925 München (DE)

(54) **A method and apparatus for passing bus mastership**

(57) A method for passing mastership of a bus is described. According to the method, it is determined whether to use the bus. If the bus is to be used, it is determined whether the bus is available. If the bus is available, the bus is accessed and a signal is generated to indicate that the bus is being accessed. A timer is also started and access to the bus is yielded when the timer expires. A processor that passes mastership to a shared resource is also described. The processor comprises a resource accessing unit. The resource accessing unit allows the processor to access a resource upon receiving a first signal from a component coupled to the resource. The resource accessing unit yields access of the resource to the component upon receiving a second signal from the component.

FIG. 7

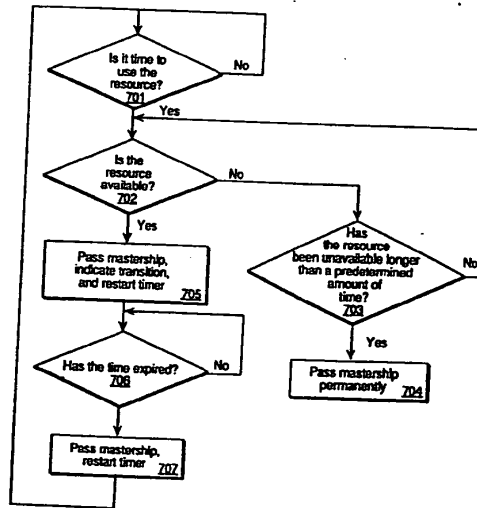

EP 0 810 530 A2

Description**FIELD OF THE INVENTION**

The present invention pertains to the field of bus regulation. More specifically, the present invention relates to an apparatus and method for passing bus mastership between multiple devices.

BACKGROUND OF THE INVENTION

When multiple devices reside on a bus, coordination of access to the bus is necessary. Coordination of access to the bus insures that multiple devices desiring to communicate will not assert control and data lines for different transfers at the same time and cause bus contention.

One approach to coordinating bus access is the use of one or more bus masters in the system. A bus master controls access to the bus. It initiates and controls all bus requests. A processor must be able to initiate a bus request for access to a memory device and thus is always a bus master. A memory device is usually a slave since it will respond to read and write requests but never generate its own requests.

A bus has multiple masters when there are multiple central processing units (CPUs) or when input/output (I/O) devices can initiate a bus transaction. If there are multiple masters, an arbitration scheme is required among the masters to decide who gets the bus next. A bus arbiter is typically used to implement the arbitration scheme. In a bus arbitration scheme, a device wanting to use the bus signals a bus request and is later granted the bus. After a grant, the device can use the bus, later signaling to the bus arbiter that the bus is no longer required. The bus arbiter can then grant the bus to another device. Most multiple-master buses have a set of bus signals for performing requests and grants. A bus release line is also needed if each device does not use its own request line to release the bus. Sometimes the signals used for bus arbitration have physically separate lines, while in other systems the data lines of the bus are used for this function. Arbitration is often a fixed priority, as is the case with daisy-chained devices or an approximately fair scheme that randomly chooses which master gets the bus.

The use of a bus arbiter has several drawbacks. The addition of a bus arbiter requires additional power to operate. This is a problem for computer systems operating under tight power constraints. Implementing a bus arbiter also requires additional space in the computer system. Thus, depending upon the environment of the computer system, the availability of physical space may not permit the implementation of a bus arbiter. Perhaps most importantly, the use of an additional component for the purpose of arbitration adds an undesirable cost to the overall computer system.

Thus, what is needed is an apparatus that passes ownership of a resource between a plurality of devices

without using an external arbiter.

SUMMARY OF THE INVENTION

A method for passing mastership of a resource is described. According to the method, it is determined whether to use the bus. If the bus is to be used, it is determined whether the bus is available. If the bus is available, the bus is accessed and a signal is generated to indicate that the bus is being accessed. A timer is also started and access to the bus is yielded when the timer expires.

A processor that passes mastership of a shared resource is described. The processor comprises a resource accessing unit. The resource accessing unit allows the processor to access a resource upon receiving a first signal from a component coupled to the resource. The resource accessing unit yields access of the resource to the component upon receiving a second signal from the component. The processor further comprises a signal generation unit. The signal generation unit is coupled to the resource accessing unit. The signal generation unit generates a third signal when the processor has gained access to the resource and generates a fourth signal when the processor has yielded access to the resource.

BRIEF DESCRIPTION OF THE DRAWINGS

The present invention is illustrated by way of example and not by way of limitation in the figures of the accompanying drawings, in which like references indicate similar elements and in which:

Figure 1 illustrates a multi-processor computer system implementing an embodiment of the invention; Figures 2 illustrates processors from two different computer systems implementing an embodiment of the invention;

Figures 3 illustrates the present invention as implemented in a mass storage system;

Figure 4 is a table illustrating the mastership states in one embodiment of the present invention;

Figure 5 is a state diagram illustrating the transition order of the states illustrated in Figure 4;

Figure 6 illustrates a block diagram of one embodiment of a processor implementing the present invention; and

Figure 7 is a flow chart illustrating a method of passing mastership of a shared resource.

DETAILED DESCRIPTION

A method and apparatus for accessing data in a memory is described. In the following description, for the purposes of explanation, numerous specific details are set forth in order to provide a thorough understanding of the present invention. It will be apparent, however, to one skilled in the art that the present invention may

be practiced without these specific details. In other instances, well-known structures and devices are shown in block diagram form in order to avoid unnecessarily obscuring the present invention.

Referring to Figure 1, the computer system upon which the preferred embodiment of the present invention can be implemented is shown as 100. Computer system 100 comprises a bus or other communication means 101 for communicating information, and processors 102 and 103 coupled with bus 101 for processing information. System 100 further comprises a random access memory (RAM) or other dynamic storage device 104 (referred to as main memory), coupled to bus 101 for storing information and instructions to be executed by processors 102 and 103. Main memory 104 also may be used for storing temporary variables or other intermediate information during execution of instructions by processors 102 and 103. Computer system 100 also comprises a read only memory (ROM) and/or other static storage device 106 coupled to bus 101 for storing static information and instructions for processors 102 and 103. Data storage device 107 is coupled to bus 101 for storing information and instructions. Instructions from a computer readable media which are executable by processors 102 or 103 may be stored onto data storage device 107. A data storage device 107 such as a magnetic disk or optical disk and its corresponding disk drive can be coupled to computer system 100.

Computer system 100 can also be coupled via bus 101 to a display device 121, such as a cathode ray tube (CRT), for displaying information to a computer user. An alphanumeric input device 122, including alphanumeric and other keys, is typically coupled to bus 101 for communicating information and command selections to processors 102 and 103. Another type of user input device is cursor control 123, such as a mouse, a trackball, or cursor direction keys for communicating direction information and command selections to processor 102 and for controlling cursor movement on display 121. This input device typically has two degrees of freedom in two axes, a first axis (e.g., x) and a second axis (e.g., y), which allows the device to specify positions in a plane.

Alternatively, other input devices such as a stylus or pen can be used to interact with the display. A displayed object on a computer screen can be selected by using a stylus or pen to touch the displayed object. The computer detects the selection by implementing a touch sensitive screen. Similarly, a light pen and a light sensitive screen can be used for selecting a displayed object. Such devices may thus detect selection position and the selection as a single operation instead of the "point and click," as in a system incorporating a mouse or trackball. Stylus and pen based input devices as well as touch and light sensitive screens are well known in the art. Such a system may also lack a keyboard such as 122 wherein all interface is provided via the stylus as a writing instrument (like a pen) and the written text is interpreted using optical character recognition (OCR)

techniques.

Figure 1 illustrates one embodiment of the present invention where bus 101 is shared between two processors 102 and 103 in the same computer system 100. In order to prevent bus contention, only one of processors 102 or 103 may access bus 101 at one time. Processor 102 is only allowed to access bus 101 during its designated bus mastership state. Similarly, processor 103 is only allowed to access bus 101 during its designated bus mastership state. The bus mastership state of the system is determined by tokens or signals that processors 102 and 103 generate. In one embodiment of the present invention, processors 102 and 103 generate a signal on line 130 each time they gain access to bus 101, relinquish access to bus 101 or wish to gain access to bus 101. In another embodiment of the present invention, the signal generated by one of the processors on line 130 may be a single signal or a plurality of signals. The signals generated by processor 102 are sent to processor 103 via line 130 and the signals generated by processor 103 are sent to processor 102 via line 130. Each processor has a copy of the signals generated by itself and the signals generated by the other processor. Each processor is aware of the current bus mastership state of the system 100.

Figure 2 illustrates an embodiment of the present invention where a processor 102 from a first computer system 250 and a second processor 202 from a second computer system 251 share access to a shared resource 210. Shared resource 210 is a resource which may be accessed by only one of either processor 102 or processor 202 at one time. Shared resource 210 may be, for example, a bus or a memory. Shared resource 210 may be directly coupled to processor 102 and 202 or coupled to processors 102 and 202 via other buses or components. Processor 102 is only allowed to access shared resource 210 during its designated resource mastership state. Processor 202 is only allowed to access shared resource 210 during its designated resource mastership state. The resource mastership state of the systems is determined by tokens or signals that the processors 102 and 202 generate. In one embodiment of the present invention, processors 102 and 202 generate a signal each time they gain access to shared resource 210, relinquish access to shared resource 210 or wish to gain access to shared resource 210. In one embodiment of the present invention, the signal generated by the processor 102 or 210 may be a single signal or a plurality of signals. The signals generated by processor 102 are sent to processor 202 on line 230 and the signals generated by processor 202 are sent to processor 102 on line 230. Each processor has a copy of the signals generated by itself and the other processor. Each processor is aware of the current bus mastership state of the computer systems.

Figure 3 illustrates an embodiment of the present invention as implemented in a mass storage system 300. Mass storage system 300 comprises a first array of storage elements 335 coupled to a hard disk assembly

331 and a second array of storage elements 345 coupled to a hard disk assembly 341. The first and second array of storage elements 335 and 345 are accessed by a host (not shown) via one of the host interface units 304 or 314 and one of buses 301 or 311. Buses 301 and 311 maybe implemented, for example, by a conventional fiber channel interface, a serial storage architecture interface, a small computer system interface (SCSI), a P1394 interface, or other well known interfaces. Hard disk assembly 331 comprises to interface the first array of storage elements 335 with bus 301. Hard disk assembly 341 includes a register 332 which is used for storing data to be read by processors 302 and 312. Hard disk assembly 341 operates to interface the second array of storage elements 345 with bus 311. Hard disk assembly 341 includes a register 342 which is used for storing data to be read by processors 302 and 312.

An environmental service center 325 provides environmental services such as temperature control and power to mass storage system 300. Environmental service center 325 also provides data regarding the environmental services of mass storage system 300. Environmental service center 325 may be implemented by any known circuitry. Processor 302 is coupled to bus 301 and shared bus 320. Processor 302 polls the environmental service center 325 by reading environmental service data from environmental service center 325 via shared bus 320. Processor 302 stores the environmental service data in memory unit 303. Processor 302 operates to monitor the environment of mass storage system 300 and maintains the system's integrity when the environment is out of tolerance range. Similarly, processor 312 is coupled to bus 311 and shared bus 320. Processor 312 polls the environmental service center 325 by reading environmental service data from environmental service center 325 via shared bus 320. Processor 312 stores the environmental service data in memory unit 313. Processor 312 operates to monitor the environment of mass storage system 300 and maintains the system's integrity when the environment is out of tolerance range.

Environmental service data from environmental service center 325 may only be accessed by one of processors 302 and 312 via shared bus 320 at a time. Processor 302 is only allowed to access shared bus 320 during its designated bus mastership state. Processor 312 is only allowed to access shared bus 320 during its designated bus mastership state. The bus mastership state of the system 300 is determined by tokens or signals that processors 302 and 312 generate. In one embodiment of the present invention, the bus mastership state is changed by signals generated by processors 302 or 312 when one of the processors gains access to bus 320, relinquishes access to bus 320, or wishes to gain access to bus 320. In another embodiment of the present invention, the signal generated by each processor 302 or 312 may be a single signal or a plurality of signals. In still another embodiment of the

present invention, a timer 355 in processor 302 and a timer 356 in processor 312 is set each time mastership of shared bus 320 is taken by a new master. The mastership of shared bus 320 is passed each time the timers 355 and 356 time out. The signals generated by processor 302 are sent to processor 312 via line 350 and the signals generated by processor 312 are sent to processor 302 via line 350. Each processor has a copy of the signals generated by itself and the other processor. Each processor 302 or 312 is aware of the current bus mastership state of the system 300.

In one embodiment of the present invention, there are four bus mastership states recognized by processors 302 and 312 of system 300. Figure 4 is a table illustrating the four states. At state 1, processor 302 (Device 1) has mastership of shared bus 320. State 1 occurs when processor 302 generates a 0 signal and processor 312 (Device 2) generates a 0 signal on line 350. At state 2, bus mastership is to be transferred from processor 302 to processor 312. State 2 occurs when processor 302 generates a 1 signal and processor 312 generates a 0 signal on line 350. At state 3, processor 312 has mastership of shared bus 320. State 3 occurs when processor 302 generates a 1 signal and processor 312 generates a 1 signal on line 350. At state 4, bus mastership is to be transferred from processor 312 to processor 302. State 4 occurs when processor 302 generates a 0 signal and processor 312 generates a 1 signal on line 350. Figure 5 is a state diagram illustrating the order in which states 1-4 shown in Figure 4 are executed. It should be appreciated that the number of states, the order in which the states are executed, and the number of signals used to represent the states may change depending on the implementation of the present invention.

Figure 6 illustrates one embodiment of processor 302. Processor 302 includes computation and control unit 610. In one embodiment of the present invention, computation and control unit 610 includes two fiber channel arbitrated loop ports, a block of embedded RAM, a host bus interface, and a processing unit. Computation and control unit 610 operate to poll environmental service data from the environmental service center and to control the environment of computer system 300.

Processor 302 further includes resource accessing unit 620, timer 355, and signal generation unit 631. Resource accessing unit 620 keeps track of the bus mastership states of memory storage system 300 and signals computation and control units 610 to poll the environmental service center 325 when processor 302 receives mastership of shared bus 320. Resource accessing unit 620 receives signals from processor 312 via line 350 which indicate when processor 320 is ready to transition into a next state. Resource accessing unit 620 is coupled to timer 355. Resource accessing unit 620 resets timer 355 when mastership of bus 320 is taken by a new master. After a predetermined amount of time, timer 355 times out. This informs resource

accessing unit 620 that shared bus 320 is to be passed to another master. Resource accessing unit 620 instructs signal generation unit 630 to generate a signal on line 631 to indicate that processor 302 is ready to transition into the next state. The bus mastership state of system 300 is determined by the signals generated by processors 302 and 312. Resource accessing unit 620, timer 355 and signal generation unit 630 may be implemented in hardware, software or a combination of hardware and software. In the embodiment of the invention shown in Figure 6, resource accessing unit 620, timer 355, and signal generation unit 630 are implemented in hardware external to computation and control unit 610. In an alternate embodiment of the present invention, resource accessing unit 620 and signal generation unit 630 are software modules implemented by a set of instructions executed by processor 302. Processor 312 operates similarly to processor 302 and may be implemented by the same components which may be used to implement processor 302.

The present invention allows arbitration of mastership to a shared resource between two devices where neither is master of the other without the use of an external arbiter. In a preferred embodiment of the present invention where the resource accessing unit and signal generation unit is implemented in software, arbitration is achieved without requiring additional power or space from the system.

Although Figure 6 illustrates an embodiment of the present invention where resource accessing unit 620, signal generation unit 630 and timer 355 reside inside processor 302, it should be appreciated that these components may reside in any agent sharing access to a shared resource to arbitrate access to the shared resource.

In one embodiment of the present invention, processor 302 updates the environmental service data in main memory 313 after processor 302 has polled environmental service data from environmental service center 325 and while system 300 is in a state where processor 302 has bus mastership of shared bus 320. In this embodiment of the present invention, processor 312 also updates the environmental service data in main memory 303 after processor 312 has polled environmental service data from environmental service center 325 and while system 300 is in a state where processor 312 has bus mastership of shared bus 320.

Processor 302 updates the environmental service data in main memory 313 through a data exchange. A second line (not shown) is used to communicate mastership of shared bus 320 between processors 302 and 312 during the data exchange in a manner similar to which line 350 communicates mastership of shared bus 320 during data polling. Processor 302 writes environmental service data into registers 332 and 342 of hard disk assembly 332 and 342 when it has mastership of shared bus 320 during data exchange. Processor 312 reads the environmental system data from registers 332 and 342 when it has mastership of shared bus 320 dur-

ing data exchange and stores the data into memory unit 313. Processor 302 continues to write new data into registers 332 and 342 until all the environmental service data in memory unit 303 has been written into registers 332 and 342 and transferred into main memory 313. Processor 312 operates similarly to processor 302 in updating the environmental service data in memory unit 303 when system 300 is in a state where processor 312 has mastership of shared bus 320. In an alternate embodiment of the present invention, a single line and a single set of signals are used by processors 302 and 312 to pass mastership of shared bus 320 during polling and exchange of environmental service data.

In a situation where processor 302 becomes inoperable and fails to generate a signal to processor 312 indicating that it is ready to transition into the next bus mastership state within a predetermined period of time, a timer in processor 312 will time out. This will indicate to processor 312 that processor 302 is inoperable. In response, processor 312 will take exclusive bus mastership of shared bus 320. Similarly, in a situation where processor 312 inoperable and fails to generate a signal to processor 312 indicating that it is ready to transition into the next bus generation state within a predetermined period of time, a timer in processor 302 will time out. This will indicate to processor 302 that processor 312 is inoperable. In response, processor 302 will take exclusive bus mastership of shared bus 320.

Figure 7 is a flow chart illustrating a method for passing mastership of a shared resource between two devices. At step 701, it is determined whether to use the shared resource. This determination may be made by checking a timer which records the time a first device has had access to the resource. After a first predetermined amount of time, the timer times out indicating that it is time for the second device to access the shared resource. If it is not time to use the shared resource, control returns to step 701. If it is time to use the shared resource, control proceeds to step 702.

At step 702, it is determined whether the shared resource is available. This determination may be made by checking a resource accessing unit for the current resource mastership state. If the resource mastership state is one where the first device has mastership, the shared resource is unavailable and control proceeds to step 703. If the shared resource is available, control proceeds to step 705.

At step 703, it is determined whether the first device has had mastership of the shared resource for over a second predetermined amount of time. This determination may be made by checking the timer which records the time when the first device had access to the shared resource. If the first device did not have mastership of the shared resource for over the second predetermined period of time, control returns to step 702. If the first device did have mastership of the shared resource for over the second predetermined amount of time, control proceeds to step 704.

At step 704, exclusive mastership of the shared

resource is given to the second device and the first device is excluded from being considered a possible master of the shared resource in the future.

At step 705, mastership of the shared resource is given to the second device. A signal is generated indicating that the shared resource has been accessed by the second device and the timer is reset.

At step 706, determine whether mastership of the shared resource should be passed to a different device. This determination can be made by checking to see if the timer has timed out past the first predetermined period of time. If the timer has timed out past the first predetermined period of time, it is time to pass mastership of the shared resource to a different resource and control proceeds to step 707. If the timer has not timed out past the first predetermined period of time, control returns to step 706.

At step 707, a signal is generated by the second device indicating that the second device is ready to transition to the next state of resource mastership where it is not the master of the shared resource. Control proceeds to step 701.

In the foregoing specification, the invention has been described with reference to specific embodiments thereof. It will, however, be evident that various modifications and changes may be made thereto without departing from the broader spirit and scope of the invention. The specification and drawings are, accordingly, to be regarded in an illustrative rather than a restrictive sense.

Claims

1. A method for passing bus mastership, comprising:

determining whether a bus is available;
accessing the bus and generating a signal indicating that the bus is being accessed if the bus is available;
starting a timer in response to accessing the bus; and
yielding access to the bus when the timer expires.

2. The method of claim 1 further comprising the step of restarting the timer after yielding access to the bus.

3. The method of claim 1 further comprising the step of generating a signal indicating that access to the bus has been yielded.

4. The method of claim 1 further comprising the step of determining whether the bus has been accessed longer than a predetermined amount of time if the bus is unavailable and gaining access to the bus if the bus has been accessed longer than the predetermined amount of time.

5. The method of claim 1, wherein determining whether the bus is available comprises the step of checking to see whether a bus agent has generated a signal indicating that it is accessing the bus.

6. A computer-readable medium having stored thereon sequences of instructions, the sequences of instructions including instructions which, when executed by a processor, cause the processor to perform the steps of:

determining whether a bus is available;
accessing the bus and generating a signal indicating that the bus is being accessed if the bus is available;
starting a timer in response to accessing the bus; and
yielding access to the bus when the timer expires.

7. The computer-readable medium of claim 6 further comprising instructions which, when executed by the processor, would cause the processor to perform the step of restarting the timer after yielding access to the bus.

8. The computer-readable medium of claim 6 further comprising instructions which, when executed by the processor, would cause the processor to perform the step of generating a signal indicating that access to the bus has been yielded.

9. The computer-readable medium of claim 6 further comprising instructions which, when executed by the processor, would cause the processor to perform the step of determining whether the bus has been accessed longer than a predetermined amount of time if the bus is unavailable and gaining access to the bus if the bus has been accessed longer than the predetermined amount of time.

10. The computer-readable medium of claim 6, wherein the step of determining whether the bus is available comprises the step of checking to see whether a bus agent has generated a signal indicating that it is accessing the bus.

11. A processor, comprising:

a resource accessing unit allowing the processor to access a resource upon receiving a first signal from a component coupled to the resource and yielding access of the resource to the component upon receiving a second signal from the component.

12. The processor of claim 11 further comprising:

a signal generation unit, coupled to the

resource accessing unit, generating a third signal when the processor has gained access to the resource and generating a fourth signal when the processor has yielded access to the resource.

13. The apparatus of claim 11 further comprising a timer, coupled to the signal generation unit, allocating a time period when the third and fourth signals are generated.

14. The apparatus of claim 11, wherein the component is a second processor.

15. The apparatus of claim 11, wherein the component is a plurality of processors.

16. The apparatus of claim 11, wherein the resource is a bus.

17. The apparatus of claim 11, wherein the resource is a memory.

18. A computer system, comprising

- (A) a bus;
- (B) a first processor, coupled to the bus, having

(1) a first signal generation unit generating a first signal when the first processor has gained access to the bus and generating a second signal when the first processor has yielded access to the bus; and

(2) a first bus accessing unit allowing the first processor to access the bus upon receiving a third signal and yielding access to the bus upon receiving a fourth signal;

- (C) a second processor, coupled to the bus and the first processor, having

(1) a second signal generation unit generating the fourth signal when the second processor has gained access to the bus and generating the third signal when the second processor has yielded access to the bus; and

(2) a second bus accessing unit allowing the second processor to access the bus upon receiving the second signal and yielding access to the bus upon receiving the first signal.

19. The computer system of claim 18 further comprising an array of storage devices coupled to the first and second processors.

20. The computer system of claim 18 further comprising an environmental service center coupled to the

bus.

21. A bus arbitrating apparatus residing in a bus agent configured to communicate with a processor based system including a memory, bus, and display, comprising:

a resource accessing unit allowing the bus agent to access the bus upon receiving a first signal from a component coupled to the bus and yielding access of the bus to the component upon receiving a second signal from the component.

22. The bus arbitrating apparatus of claim 21, further comprising:

a signal generation unit, coupled to the resource accessing unit, generating a third signal when the bus agent has gained access to the resource and generating a fourth signal when the bus agent has yielded access to the resource.

23. A system for arbitrating a bus between a first bus agent and a second bus agent comprising:

a first signal generation unit generating a first signal when the first bus agent has gained access to the bus and generating a second signal when the first bus agent has yielded access to the bus;

a first bus accessing unit allowing the first bus agent to access the bus upon receiving a third signal and yielding access to the bus upon receiving a fourth signal, wherein the first signal generation unit and the first bus accessing unit reside inside the first bus agent;

a second signal generation unit generating the fourth signal when the second bus agent has gained access to the bus and generating the third signal when the second bus agent has yielded access to the bus; and

a second bus accessing unit allowing the second bus agent to access the bus upon receiving the second signal and yielding access to the bus upon receiving the first signal, wherein the second signal generation unit and second bus accessing unit reside inside the second bus agent.

24. The system of claim 23 further comprising an array of storage devices coupled to the first and second bus agents.

25. The system of claim 23 further comprising an environmental service center coupled to the bus.

FIG. 1

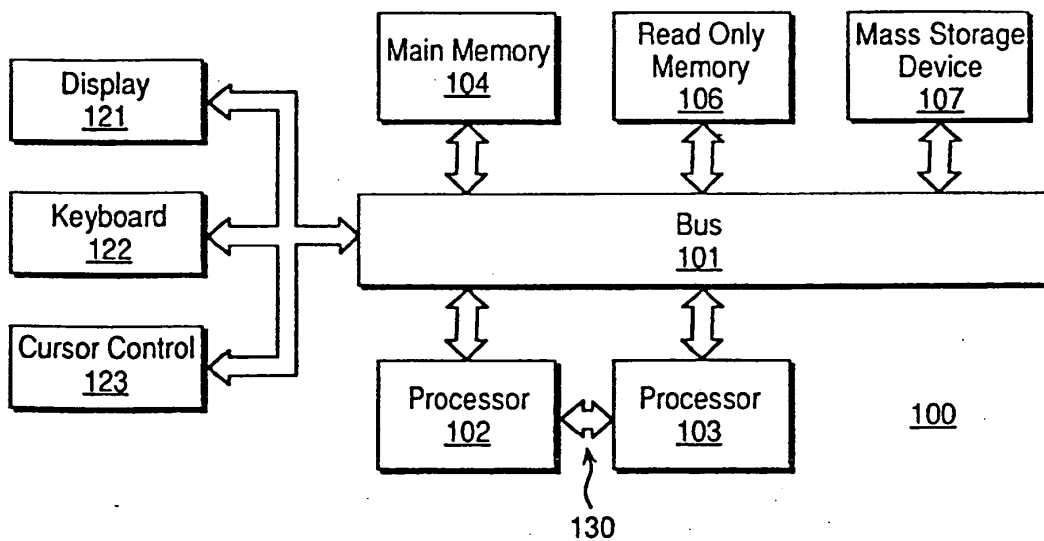

FIG. 2

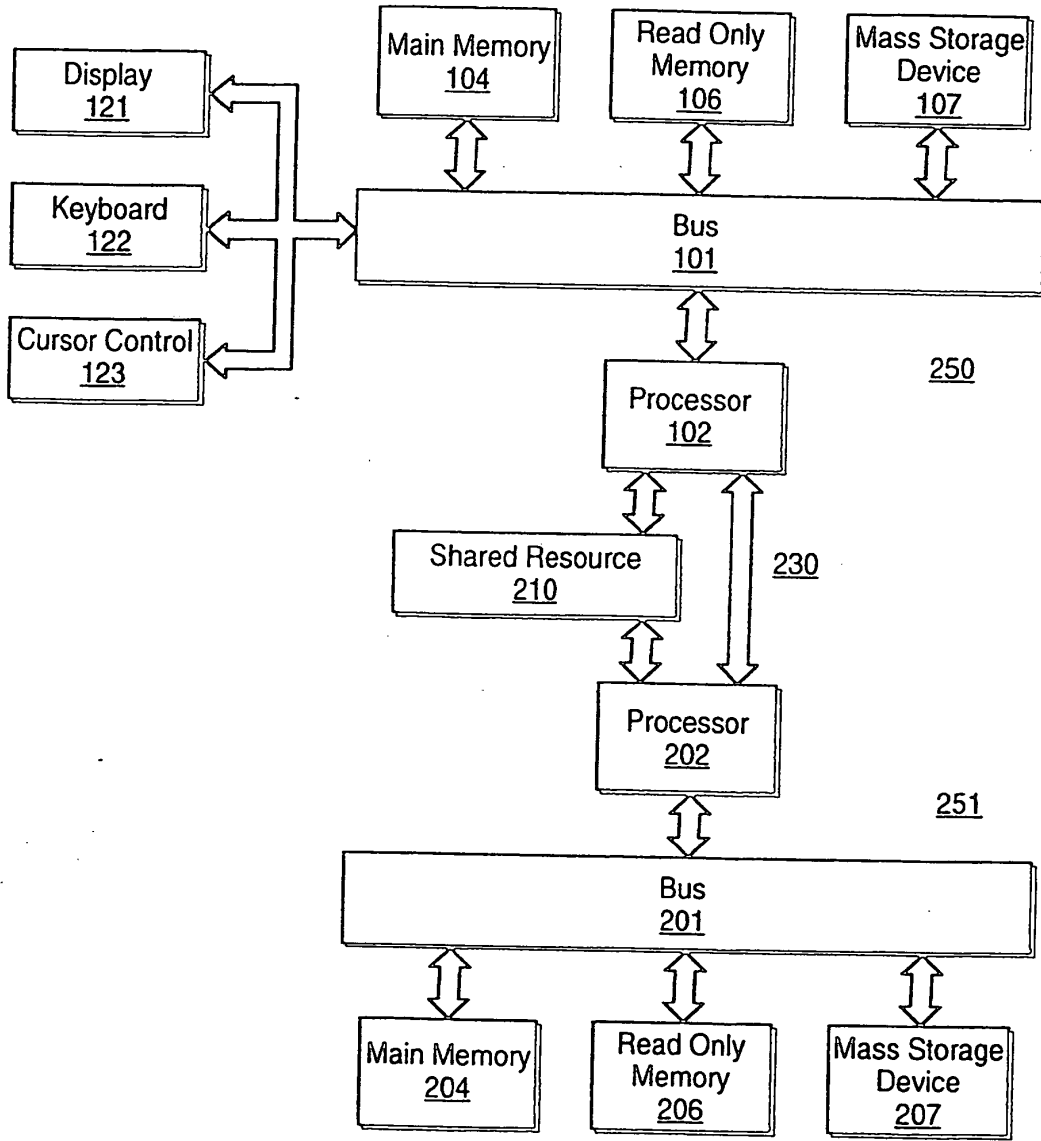

FIG. 3

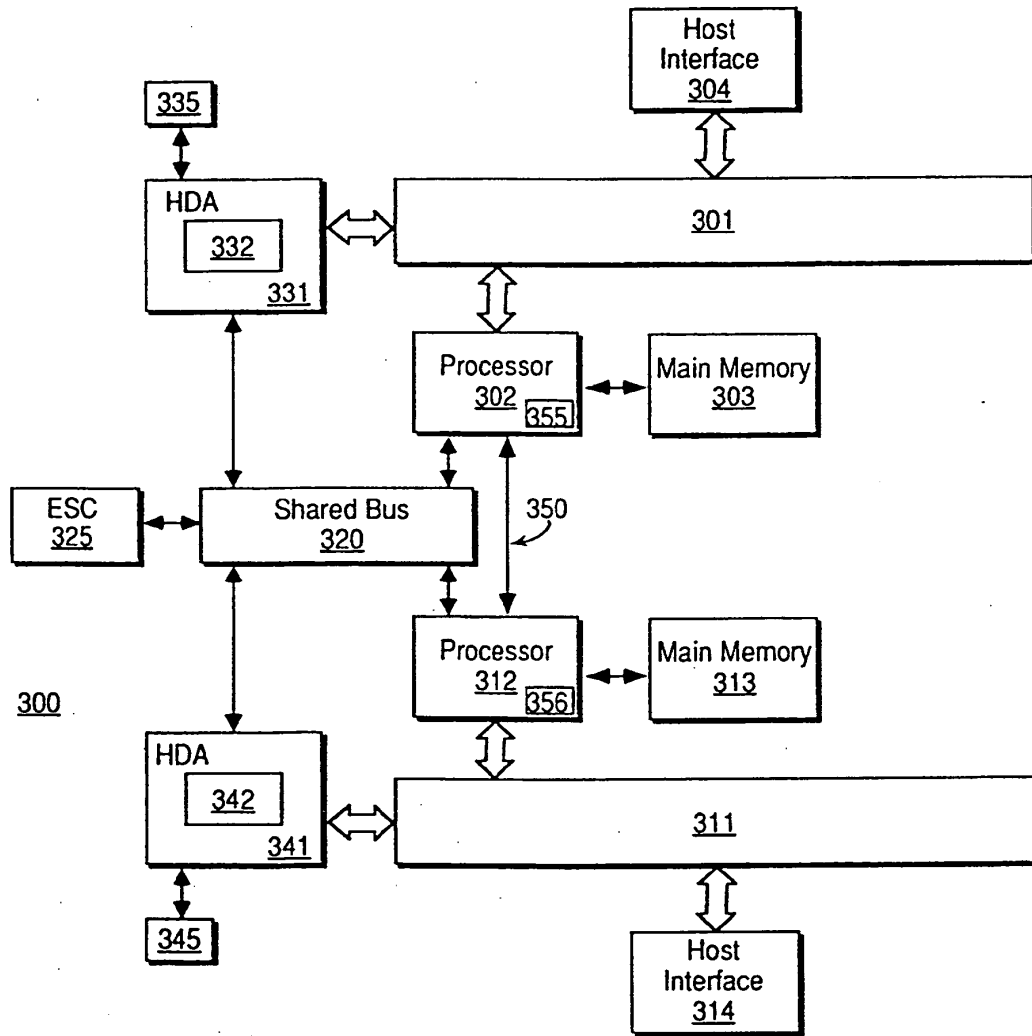

FIG. 4

State	Device 1	Device 2	Mastership
1	0	0	Device 1 is master
2	1	0	Mastership is to be passed from Device 1 to Device 2
3	1	1	Device 2 is master
4	0	1	Mastership is to be passed from Device 2 to Device 1

FIG. 5

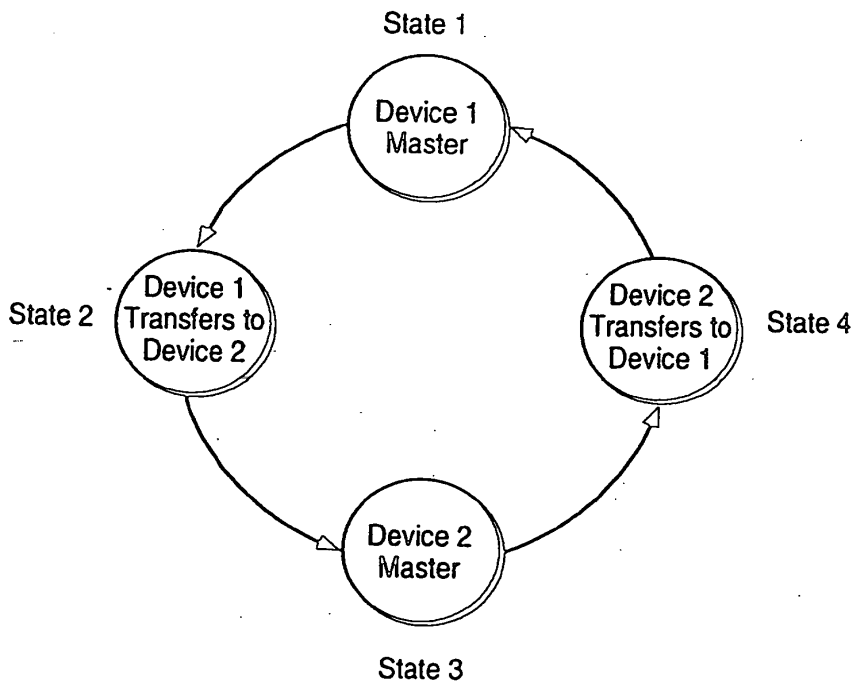

FIG. 6

302

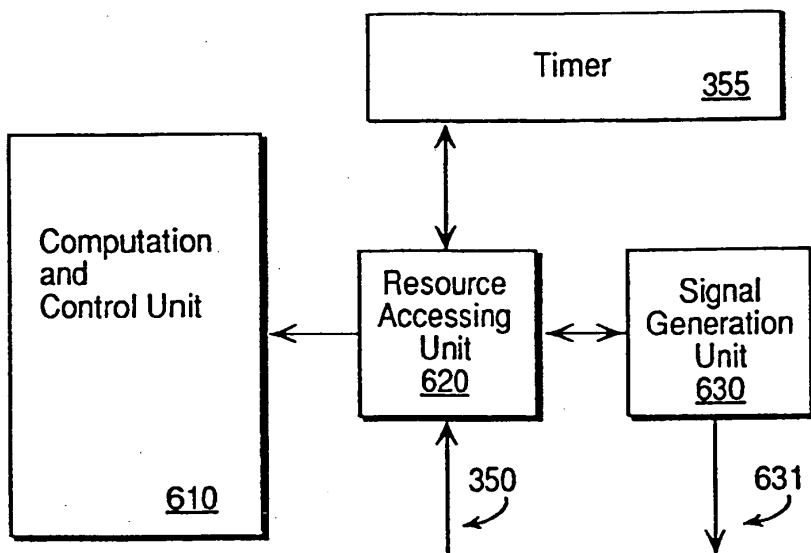
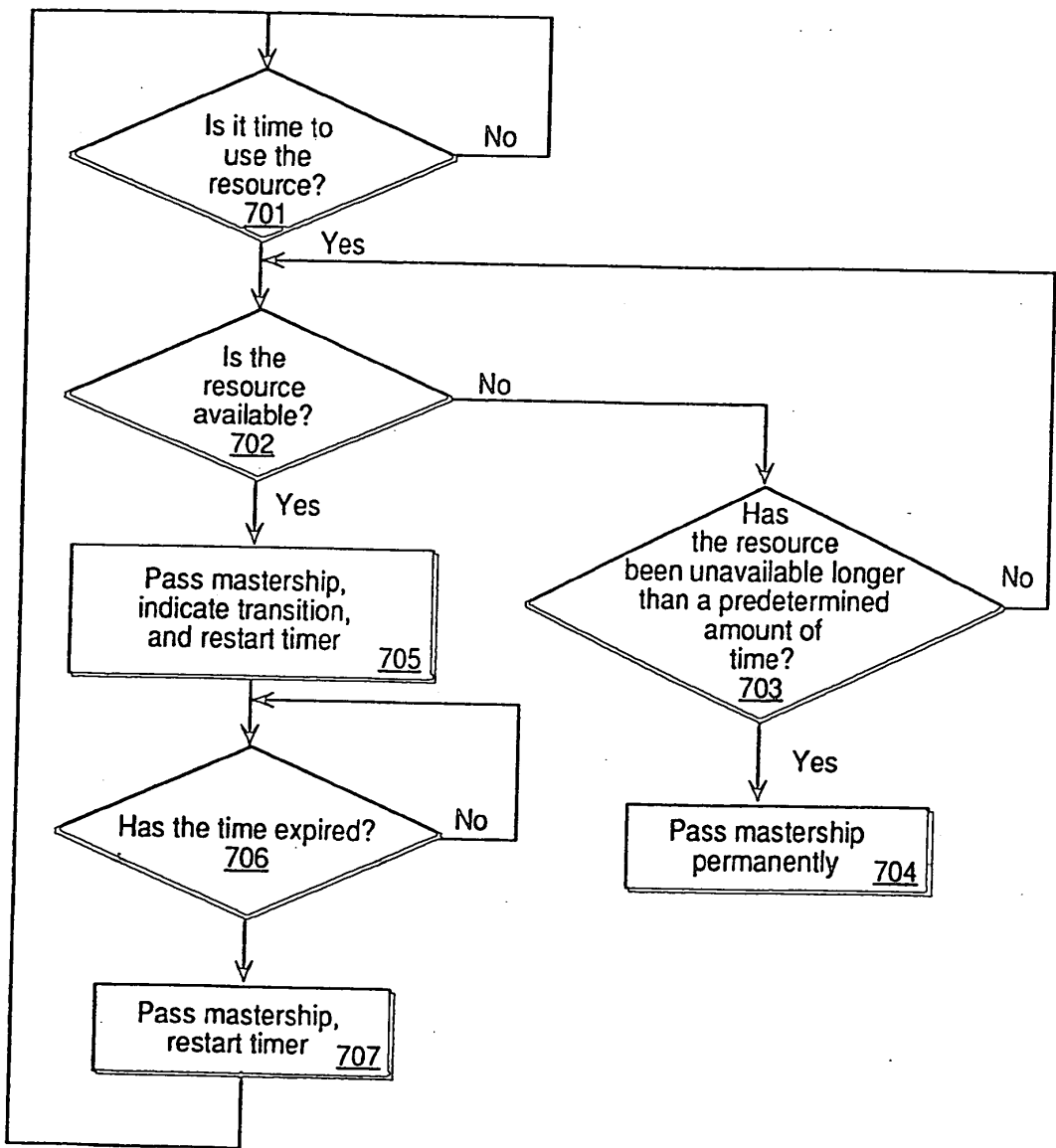

FIG. 7



Please type a plus sign (+) inside this box

+

PTO/SB/05 (2/98)

UTILITY PATENT APPLICATION TRANSMITTAL <small>(Only for nonprovisional applications under 37 CFR § 1.53(b))</small>	Attorney Docket No.	CROSS1120-13	
	First Inventor or Application Identifier	Geoffrey B. Hoese	
	Title	Storage Router and Method for Providing Virtual Local Storage	
	Express Mail Label No.	EV351125056US	
APPLICATION ELEMENTS <small>See MPEP chapter 600 concerning utility patent application contents.</small>		ADDRESS TO: Box Patent Application Assistant Commissioner for Patents Washington, D.C. 20231	
1. <input checked="" type="checkbox"/> Fee Transmittal for FY 2003 <small>(Submit an original and a duplicate for fee processing)</small>	6. <input type="checkbox"/> Microfiche Computer Program (Appendix)	03940 U.S. PTO 107656163 09/09/03	
2. <input checked="" type="checkbox"/> Specification [Total Pages] 28 <small>(preferred arrangement set forth below)</small> <input checked="" type="checkbox"/> Descriptive Title of the Invention <input type="checkbox"/> Cross References to Related Applications <input type="checkbox"/> Statement Regarding Fed Sponsored R & D <input checked="" type="checkbox"/> Description of Related Art <input checked="" type="checkbox"/> Field of the Invention <input checked="" type="checkbox"/> Summary of the Invention <input checked="" type="checkbox"/> Brief Description of the Drawings (if filed) <input checked="" type="checkbox"/> Claim(s) <input checked="" type="checkbox"/> Abstract of the Disclosure	7. Nucleotide and Amino Acid Sequence Submission <small>(if applicable, all necessary)</small> a. <input type="checkbox"/> Computer-Readable Copy b. <input type="checkbox"/> Paper Copy (identical to computer copy) c. <input type="checkbox"/> Statement verifying identity of above copies		
3. <input checked="" type="checkbox"/> Drawing(s) (35 USC 113) [Total Sheets] 2	ACCOMPANYING APPLICATION PARTS		
4. <input checked="" type="checkbox"/> Oath or Declaration (executed) 4 <small>[Total Pages]</small> a. <input type="checkbox"/> Newly executed (original or copy) b. <input checked="" type="checkbox"/> Copy from a prior application (37 CFR 1.63(d)) <small>(for continuation/divisional with Box 17 completed)</small> i. <input type="checkbox"/> DELETION OF INVENTOR(S) <small>Signed statement attached deleting inventor(s) named in the prior application, see 37 CFR 1.63(d)(2) and 1.33(b)</small>	8. <input checked="" type="checkbox"/> Assignment Papers (cover sheet & document(s)) 9. <input type="checkbox"/> 37 CFR 3.73(b) Statement <input checked="" type="checkbox"/> Power of Attorney <small>(when there is an assignee)</small> 10. <input type="checkbox"/> English Translation Document (if applicable) 11. <input type="checkbox"/> Information Disclosure Statement (IDS)/PTO-1449 <input type="checkbox"/> Copies of IDS Citations 12. <input checked="" type="checkbox"/> Preliminary Amendment 13. <input checked="" type="checkbox"/> Return Receipt Postcard 14. <input checked="" type="checkbox"/> Small Entity <input type="checkbox"/> Statement filed in prior application, Status still proper and desired 15. <input type="checkbox"/> Certified Copy of Priority Document(s) <small>(if foreign priority is claimed)</small> 16. <input checked="" type="checkbox"/> Other: Certificate of Mailing; Revocation and Power of Attorney; Acceptance of Revocation and POA		
5. <input checked="" type="checkbox"/> Incorporation By Reference (useable if box 4b is checked). <small>The entire disclosure of the prior application, from which a copy of the oath or declaration is supplied under Box 4b, is considered to be part of the disclosure of the accompanying application and is hereby incorporated by reference therein.</small>	17. If a CONTINUING APPLICATION, check appropriate box and supply the requisite information below and in a preliminary amendment <input checked="" type="checkbox"/> Continuation <input type="checkbox"/> Divisional <input type="checkbox"/> Continuation-In-Part (CIP) of prior Application No.: 10/081,110 <small>Prior application information: Examiner Christopher B. Shin Group / Art Unit 2182</small>		
<input type="checkbox"/> Claims the benefit of Provisional Application No. _____			
CORRESPONDENCE ADDRESS:			
Gray Cary Ware & Freidenrich LLP 1221 South MoPac Expressway, Suite 400 Austin, TX 78746-6875 Tel. (512) 457-7142 Fax. (512) 457-7001	Customer No. : 25094		

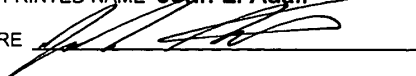
TYPED or PRINTED NAME **John L. Adair**
 SIGNATURE 

REGISTRATION NO. **48,828**
 DATE: **September 9, 2003**

Gray Cary\AU4113226.1
 103671-990000

IN THE UNITED STATES PATENT AND TRADEMARK OFFICE	
CERTIFICATE OF MAILING BY "EXPRESS MAIL"	Atty Docket No. CROSS1120-13
Mail Stop: Patent Application Commissioner for Patents P.O. Box 1450 Alexandria, VA 22313 Sir:	In the Application of: Geoffrey B. Hoese, et al.
	Date Filed: September 9, 2003
	Title: Storage Router and Method for Providing Virtual Local Storage

I hereby certify that the Preliminary Amendment, Utility Patent Application Transmittal Form, Fee Transmittal, Utility Patent Application from Parent Case, Declaration and Power of Attorney from Parent Case, Revocation and Power of Attorney from Parent Case, Acceptance of Revocation and Power of Attorney from Parent, Assignment and Recordation Cover Sheet from Parent, two (2) pages of Formal Drawings from Parent, filing fee and Postcard are being deposited with the United States Postal Service "EXPRESS MAIL Post Office to Addressee" service under 37 C.F.R. § 1.10, Mailing Label Certificate No. EV351125056US, on **September 9, 2003**, addressed to: Mail Stop: Patent Application, Commissioner for Patents, Alexandria, VA 22313.

Respectfully submitted,
Gray Cary Ware & Freidenrich LLP

 Janice Pampell

17264 U.S. PTO
09/09/03

Under the Paperwork Reduction Act of 1995, no persons are required to respond to a collection of information unless it displays a valid OMB control number.

**FEE TRANSMITTAL
for FY 2003**

Effective 01/01/2003. Patent fees are subject to annual revision.

Applicant claims small entity status. See 37 CFR 1.27

TOTAL AMOUNT OF PAYMENT (\$) 714.00

Complete if Known

Application Number	Unknown
Filing Date	September 9, 2003
First Named Inventor	Geoffrey B. Hoese
Examiner Name	Unknown
Art Unit	Unknown
Attorney Docket No.	CROSS1120-13

METHOD OF PAYMENT (check all that apply)		FEE CALCULATION (continued)																																																																																																																						
<input checked="" type="checkbox"/> Check <input type="checkbox"/> Credit Card <input type="checkbox"/> Money Order <input type="checkbox"/> Other <input type="checkbox"/> None		3. ADDITIONAL FEES																																																																																																																						
Deposit Account Number: 50-0456 Deposit Account Name: Gray Cary Ware & Freidenrich LLP	<table border="1"> <thead> <tr> <th>Large Entity</th> <th>Small Entity</th> <th>Fee Description</th> <th>Fee Paid</th> </tr> </thead> <tbody> <tr><td>1051</td><td>130</td><td>2051 65 Surcharge - late filing fee or oath</td><td></td></tr> <tr><td>1052</td><td>50</td><td>2052 25 Surcharge - late provisional filing fee or cover sheet</td><td></td></tr> <tr><td>1053</td><td>130</td><td>1053 130 Non-English specification</td><td></td></tr> <tr><td>1812</td><td>2,520</td><td>1812 2,520 For filing a request for ex parte reexamination</td><td></td></tr> <tr><td>1804</td><td>920*</td><td>1804 920* Requesting publication of SIR prior to Examiner action</td><td></td></tr> <tr><td>1805</td><td>1,840*</td><td>1805 1,840* Requesting publication of SIR after Examiner action</td><td></td></tr> <tr><td>1251</td><td>110</td><td>2251 55 Extension for reply within first month</td><td></td></tr> <tr><td>1252</td><td>410</td><td>2252 205 Extension for reply within second month</td><td></td></tr> <tr><td>1253</td><td>930</td><td>2253 465 Extension for reply within third month</td><td></td></tr> <tr><td>1254</td><td>1,450</td><td>2254 725 Extension for reply within fourth month</td><td></td></tr> <tr><td>1255</td><td>1,970</td><td>2255 985 Extension for reply within fifth month</td><td></td></tr> <tr><td>1401</td><td>320</td><td>2401 160 Notice of Appeal</td><td></td></tr> <tr><td>1402</td><td>320</td><td>2402 160 Filing a brief in support of an appeal</td><td></td></tr> <tr><td>1403</td><td>280</td><td>2403 140 Request for oral hearing</td><td></td></tr> <tr><td>1451</td><td>1,510</td><td>1451 1,510 Petition to institute a public use proceeding</td><td></td></tr> <tr><td>1452</td><td>110</td><td>2452 55 Petition to revive - unavoidable</td><td></td></tr> <tr><td>1453</td><td>1,300</td><td>2453 650 Petition to revive - unintentional</td><td></td></tr> <tr><td>1501</td><td>1,300</td><td>2501 650 Utility issue fee (or reissue)</td><td></td></tr> <tr><td>1502</td><td>470</td><td>2502 235 Design issue fee</td><td></td></tr> <tr><td>1503</td><td>630</td><td>2503 315 Plant issue fee</td><td></td></tr> <tr><td>1460</td><td>130</td><td>1460 130 Petitions to the Commissioner</td><td></td></tr> <tr><td>1807</td><td>50</td><td>1807 50 Processing fee under 37 CFR 1.17(c)</td><td></td></tr> <tr><td>1806</td><td>180</td><td>1806 180 Submission of Information Disclosure Stmt</td><td></td></tr> <tr><td>8021</td><td>40</td><td>8021 40 Recording each patent assignment per property (times number of properties)</td><td></td></tr> <tr><td>1809</td><td>750</td><td>2809 375 Filing a submission after final rejection (37 CFR § 1.129(a))</td><td></td></tr> <tr><td>1810</td><td>750</td><td>2810 375 For each additional invention to be examined (37 CFR § 1.129(b))</td><td></td></tr> <tr><td>1801</td><td>750</td><td>2801 375 Request for Continued Examination (RCE)</td><td></td></tr> <tr><td>1802</td><td>900</td><td>1802 900 Request for expedited examination of a design application</td><td></td></tr> </tbody> </table>		Large Entity	Small Entity	Fee Description	Fee Paid	1051	130	2051 65 Surcharge - late filing fee or oath		1052	50	2052 25 Surcharge - late provisional filing fee or cover sheet		1053	130	1053 130 Non-English specification		1812	2,520	1812 2,520 For filing a request for ex parte reexamination		1804	920*	1804 920* Requesting publication of SIR prior to Examiner action		1805	1,840*	1805 1,840* Requesting publication of SIR after Examiner action		1251	110	2251 55 Extension for reply within first month		1252	410	2252 205 Extension for reply within second month		1253	930	2253 465 Extension for reply within third month		1254	1,450	2254 725 Extension for reply within fourth month		1255	1,970	2255 985 Extension for reply within fifth month		1401	320	2401 160 Notice of Appeal		1402	320	2402 160 Filing a brief in support of an appeal		1403	280	2403 140 Request for oral hearing		1451	1,510	1451 1,510 Petition to institute a public use proceeding		1452	110	2452 55 Petition to revive - unavoidable		1453	1,300	2453 650 Petition to revive - unintentional		1501	1,300	2501 650 Utility issue fee (or reissue)		1502	470	2502 235 Design issue fee		1503	630	2503 315 Plant issue fee		1460	130	1460 130 Petitions to the Commissioner		1807	50	1807 50 Processing fee under 37 CFR 1.17(c)		1806	180	1806 180 Submission of Information Disclosure Stmt		8021	40	8021 40 Recording each patent assignment per property (times number of properties)		1809	750	2809 375 Filing a submission after final rejection (37 CFR § 1.129(a))		1810	750	2810 375 For each additional invention to be examined (37 CFR § 1.129(b))		1801	750	2801 375 Request for Continued Examination (RCE)		1802	900	1802 900 Request for expedited examination of a design application		Fee Code Fee (\$) Fee Code Fee (\$)	
Large Entity	Small Entity	Fee Description	Fee Paid																																																																																																																					
1051	130	2051 65 Surcharge - late filing fee or oath																																																																																																																						
1052	50	2052 25 Surcharge - late provisional filing fee or cover sheet																																																																																																																						
1053	130	1053 130 Non-English specification																																																																																																																						
1812	2,520	1812 2,520 For filing a request for ex parte reexamination																																																																																																																						
1804	920*	1804 920* Requesting publication of SIR prior to Examiner action																																																																																																																						
1805	1,840*	1805 1,840* Requesting publication of SIR after Examiner action																																																																																																																						
1251	110	2251 55 Extension for reply within first month																																																																																																																						
1252	410	2252 205 Extension for reply within second month																																																																																																																						
1253	930	2253 465 Extension for reply within third month																																																																																																																						
1254	1,450	2254 725 Extension for reply within fourth month																																																																																																																						
1255	1,970	2255 985 Extension for reply within fifth month																																																																																																																						
1401	320	2401 160 Notice of Appeal																																																																																																																						
1402	320	2402 160 Filing a brief in support of an appeal																																																																																																																						
1403	280	2403 140 Request for oral hearing																																																																																																																						
1451	1,510	1451 1,510 Petition to institute a public use proceeding																																																																																																																						
1452	110	2452 55 Petition to revive - unavoidable																																																																																																																						
1453	1,300	2453 650 Petition to revive - unintentional																																																																																																																						
1501	1,300	2501 650 Utility issue fee (or reissue)																																																																																																																						
1502	470	2502 235 Design issue fee																																																																																																																						
1503	630	2503 315 Plant issue fee																																																																																																																						
1460	130	1460 130 Petitions to the Commissioner																																																																																																																						
1807	50	1807 50 Processing fee under 37 CFR 1.17(c)																																																																																																																						
1806	180	1806 180 Submission of Information Disclosure Stmt																																																																																																																						
8021	40	8021 40 Recording each patent assignment per property (times number of properties)																																																																																																																						
1809	750	2809 375 Filing a submission after final rejection (37 CFR § 1.129(a))																																																																																																																						
1810	750	2810 375 For each additional invention to be examined (37 CFR § 1.129(b))																																																																																																																						
1801	750	2801 375 Request for Continued Examination (RCE)																																																																																																																						
1802	900	1802 900 Request for expedited examination of a design application																																																																																																																						
1. BASIC FILING FEE		Other fee (specify) _____		SUBTOTAL (3) (\$)																																																																																																																				
<table border="1"> <thead> <tr> <th>Large Entity</th> <th>Small Entity</th> <th>Fee Description</th> <th>Fee Paid</th> </tr> </thead> <tbody> <tr><td>1001</td><td>750</td><td>2001 375 Utility filing fee</td><td>375.00</td></tr> <tr><td>1002</td><td>330</td><td>2002 165 Design filing fee</td><td></td></tr> <tr><td>1003</td><td>520</td><td>2003 260 Plant filing fee</td><td></td></tr> <tr><td>1004</td><td>750</td><td>2004 375 Reissue filing fee</td><td></td></tr> <tr><td>1005</td><td>160</td><td>2005 80 Provisional filing fee</td><td></td></tr> </tbody> </table>		Large Entity	Small Entity	Fee Description	Fee Paid	1001	750	2001 375 Utility filing fee	375.00	1002	330	2002 165 Design filing fee		1003	520	2003 260 Plant filing fee		1004	750	2004 375 Reissue filing fee		1005	160	2005 80 Provisional filing fee		2. EXTRA CLAIM FEES FOR UTILITY AND REISSUE		SUBTOTAL (1) (\$) 375.00																																																																																												
Large Entity	Small Entity	Fee Description	Fee Paid																																																																																																																					
1001	750	2001 375 Utility filing fee	375.00																																																																																																																					
1002	330	2002 165 Design filing fee																																																																																																																						
1003	520	2003 260 Plant filing fee																																																																																																																						
1004	750	2004 375 Reissue filing fee																																																																																																																						
1005	160	2005 80 Provisional filing fee																																																																																																																						
<table border="1"> <thead> <tr> <th>Total Claims</th> <th>Extra Claims</th> <th>Fee from below</th> <th>Fee Paid</th> </tr> </thead> <tbody> <tr> <td>39</td> <td>-20** = 19</td> <td>9</td> <td>171.00</td> </tr> <tr> <td>Independent Claims</td> <td>7</td> <td>-3** = 4</td> <td>42 = 168.00</td> </tr> <tr> <td>Multiple Dependent</td> <td></td> <td>X</td> <td>=</td> </tr> </tbody> </table>		Total Claims	Extra Claims	Fee from below	Fee Paid	39	-20** = 19	9	171.00	Independent Claims	7	-3** = 4	42 = 168.00	Multiple Dependent		X	=	<table border="1"> <thead> <tr> <th>Large Entity</th> <th>Small Entity</th> <th>Fee Description</th> <th>Fee Paid</th> </tr> </thead> <tbody> <tr><td>1202</td><td>18</td><td>2202 9 Claims in excess of 20</td><td></td></tr> <tr><td>1201</td><td>84</td><td>2201 42 Independent claims in excess of 3</td><td></td></tr> <tr><td>1203</td><td>280</td><td>2203 140 Multiple dependent claim, if not paid</td><td></td></tr> <tr><td>1204</td><td>84</td><td>2204 42 ** Reissue independent claims over original patent</td><td></td></tr> <tr><td>1205</td><td>18</td><td>2205 9 ** Reissue claims in excess of 20 and over original patent</td><td></td></tr> </tbody> </table>		Large Entity	Small Entity	Fee Description	Fee Paid	1202	18	2202 9 Claims in excess of 20		1201	84	2201 42 Independent claims in excess of 3		1203	280	2203 140 Multiple dependent claim, if not paid		1204	84	2204 42 ** Reissue independent claims over original patent		1205	18	2205 9 ** Reissue claims in excess of 20 and over original patent		SUBTOTAL (2) (\$) 339.00																																																																												
Total Claims	Extra Claims	Fee from below	Fee Paid																																																																																																																					
39	-20** = 19	9	171.00																																																																																																																					
Independent Claims	7	-3** = 4	42 = 168.00																																																																																																																					
Multiple Dependent		X	=																																																																																																																					
Large Entity	Small Entity	Fee Description	Fee Paid																																																																																																																					
1202	18	2202 9 Claims in excess of 20																																																																																																																						
1201	84	2201 42 Independent claims in excess of 3																																																																																																																						
1203	280	2203 140 Multiple dependent claim, if not paid																																																																																																																						
1204	84	2204 42 ** Reissue independent claims over original patent																																																																																																																						
1205	18	2205 9 ** Reissue claims in excess of 20 and over original patent																																																																																																																						
**or number previously paid, if greater; For Reissues, see above		*Reduced by Basic Filing Fee Paid		SUBTOTAL (3) (\$)																																																																																																																				

SUBMITTED BY		<i>Complete (if applicable)</i>	
Name (Print/Type)	John L. Adair	Registration No. (Attorney/Agent)	48,828
Signature		Telephone	512-457-7142
		Date	September 9, 2003

WARNING: Information on this form may become public. Credit card information should not be included on this form. Provide credit card information and authorization on PTO-2038.

This collection of information is required by 37 CFR 1.17 and 1.27. The information is required to obtain or retain a benefit by the public which is to file (and by the USPTO to process) an application. Confidentiality is governed by 35 U.S.C. 122 and 37 CFR 1.14. This collection is estimated to take 12 minutes to complete, including gathering, preparing, and submitting the completed application form to the USPTO. Time will vary depending upon the individual case. Any comments on the amount of time you require to complete this form and/or suggestions for reducing this burden, should be sent to the Chief Information Officer, U.S. Patent and Trademark Office, U.S. Department of Commerce, Washington, DC 20231. DO NOT SEND FEES OR COMPLETED FORMS TO THIS ADDRESS. SEND TO: Commissioner for Patents, Washington, DC 20231.

Gray Cary/AU4113227.1

ATTORNEYS DOCKET
064113.0103

PATENT APPLICATION

1

Copy from Prior Application

STORAGE ROUTER AND METHOD FOR
PROVIDING VIRTUAL LOCAL STORAGE

TECHNICAL FIELD OF THE INVENTION

This invention relates in general to network storage devices, and more particularly to a storage router and method for providing virtual local storage on remote SCSI storage devices to Fibre Channel devices.

5

AUS01:110067

BACKGROUND OF THE INVENTION

Typical storage transport mediums provide for a relatively small number of devices to be attached over relatively short distances. One such transport medium is a Small Computer System Interface (SCSI) protocol, the structure and operation of which is generally well known as is described, for example, in the SCSI-1, SCSI-2 and SCSI-3 specifications. High speed serial interconnects provide enhanced capability to attach a large number of high speed devices to a common storage transport medium over large distances. One such serial interconnect is Fibre Channel, the structure and operation of which is described, for example, in *Fibre Channel Physical and Signaling Interface (FC-PH)*, ANSI X3.230 *Fibre Channel Arbitrated Loop (FC-AL)*, and ANSI X3.272 *Fibre Channel Private Loop Direct Attach (FC-PLDA)*.

Conventional computing devices, such as computer workstations, generally access storage locally or through network interconnects. Local storage typically consists of a disk drive, tape drive, CD-ROM drive or other storage device contained within, or locally connected to the workstation. The workstation provides a file system structure, that includes security controls, with access to the local storage device through native low level, block protocols. These protocols map directly to the mechanisms used by the storage device and consist of data requests without security controls. Network interconnects typically provide access for a large number of computing

devices to data storage on a remote network server. The remote network server provides file system structure, access control, and other miscellaneous capabilities that include the network interface. Access to data through
5 the network server is through network protocols that the server must translate into low level requests to the storage device. A workstation with access to the server storage must translate its file system protocols into network protocols that are used to communicate with the
10 server. Consequently, from the perspective of a workstation, or other computing device, seeking to access such server data, the access is much slower than access to data on a local storage device.

SUMMARY OF THE INVENTION

In accordance with the present invention, a storage router and method for providing virtual local storage on remote SCSI storage devices to Fibre Channel devices are disclosed that provide advantages over conventional network storage devices and methods.

According to one aspect of the present invention, a storage router and storage network provide virtual local storage on remote SCSI storage devices to Fibre Channel devices. A plurality of Fibre Channel devices, such as workstations, are connected to a Fibre Channel transport medium, and a plurality of SCSI storage devices are connected to a SCSI bus transport medium. The storage router interfaces between the Fibre Channel transport medium and the SCSI bus transport medium. The storage router maps between the workstations and the SCSI storage devices and implements access controls for storage space on the SCSI storage devices. The storage router then allows access from the workstations to the SCSI storage devices using native low level, block protocol in accordance with the mapping and the access controls.

According to another aspect of the present invention, virtual local storage on remote SCSI storage devices is provided to Fibre Channel devices. A Fibre Channel transport medium and a SCSI bus transport medium are interfaced with. A configuration is maintained for SCSI storage devices connected to the SCSI bus transport medium. The configuration maps between Fibre Channel

devices and the SCSI storage devices and implements
access controls for storage space on the SCSI storage
devices. Access is then allowed from Fibre Channel
initiator devices to SCSI storage devices using native
5 low level, block protocol in accordance with the
configuration.

A technical advantage of the present invention is
the ability to centralize local storage for networked
workstations without any cost of speed or overhead. Each
10 workstation access its virtual local storage as if it
work locally connected. Further, the centralized storage
devices can be located in a significantly remote position
even in excess of ten kilometers as defined by Fibre
Channel standards.

15 Another technical advantage of the present invention
is the ability to centrally control and administer
storage space for connected users without limiting the
speed with which the users can access local data. In
addition, global access to data, backups, virus scanning
20 and redundancy can be more easily accomplished by
centrally located storage devices.

A further technical advantage of the present
invention is providing support for SCSI storage devices
as local storage for Fibre Channel hosts. In addition,
25 the present invention helps to provide extended
capabilities for Fibre Channel and for management of
storage subsystems.

BRIEF DESCRIPTION OF THE DRAWINGS

A more complete understanding of the present invention and the advantages thereof may be acquired by referring to the following description taken in
5 conjunction with the accompanying drawings, in which like reference numbers indicate like features, and wherein:

FIGURE 1 is a block diagram of a conventional network that provides storage through a network server;

10 FIGURE 2 is a block diagram of one embodiment of a storage network with a storage router that provides global access and routing;

FIGURE 3 is a block diagram of one embodiment of a storage network with a storage router that provides virtual local storage;

15 FIGURE 4 is a block diagram of one embodiment of the storage router of FIGURE 3; and

FIGURE 5 is a block diagram of one embodiment of data flow within the storage router of FIGURE 4.

DETAILED DESCRIPTION OF THE INVENTION

FIGURE 1 is a block diagram of a conventional network, indicated generally at 10, that provides access to storage through a network server. As shown, network 5 10 includes a plurality of workstations 12 interconnected with a network server 14 via a network transport medium 16. Each workstation 12 can generally comprise a processor, memory, input/output devices, storage devices and a network adapter as well as other common computer 10 components. Network server 14 uses a SCSI bus 18 as a storage transport medium to interconnect with a plurality of storage devices 20 (tape drives, disk drives, etc.). In the embodiment of FIGURE 1, network transport medium 16 is an network connection and storage devices 20 15 comprise hard disk drives, although there are numerous alternate transport mediums and storage devices.

In network 10, each workstation 12 has access to its local storage device as well as network access to data on storage devices 20. The access to a local storage device 20 is typically through native low level, block protocols. On the other hand, access by a workstation 12 to storage devices 20 requires the participation of network server 14 which implements a file system and transfers data to workstations 12 only through high level file system 25 protocols. Only network server 14 communicates with storage devices 20 via native low level, block protocols. Consequently, the network access by workstations 12 through network server 14 is slow with respect to their

access to local storage. In network 10, it can also be a logistical problem to centrally manage and administer local data distributed across an organization, including accomplishing tasks such as backups, virus scanning and redundancy.

FIGURE 2 is a block diagram of one embodiment of a storage network, indicated generally at 30, with a storage router that provides global access and routing. This environment is significantly different from that of FIGURE 1 in that there is no network server involved. In FIGURE 2, a Fibre Channel high speed serial transport 32 interconnects a plurality of workstations 36 and storage devices 38. A SCSI bus storage transport medium interconnects workstations 40 and storage devices 42. A storage router 44 then serves to interconnect these mediums and provide devices on either medium global, transparent access to devices on the other medium. Storage router 44 routes requests from initiator devices on one medium to target devices on the other medium and routes data between the target and the initiator. Storage router 44 can allow initiators and targets to be on either side. In this manner, storage router 44 enhances the functionality of Fibre Channel 32 by providing access, for example, to legacy SCSI storage devices on SCSI bus 34. In the embodiment of FIGURE 2, the operation of storage router 44 can be managed by a management station 46 connected to the storage router via a direct serial connection.

In storage network 30, any workstation 36 or workstation 40 can access any storage device 38 or storage device 42 through native low level, block protocols, and vice versa. This functionality is enabled
5 by storage router 44 which routes requests and data as a generic transport between Fibre Channel 32 and SCSI bus 34. Storage router 44 uses tables to map devices from one medium to the other and distributes requests and data across Fibre Channel 32 and SCSI bus 34 without any
10 security access controls. Although this extension of the high speed serial interconnect provided by Fibre Channel 32 is beneficial, it is desirable to provide security controls in addition to extended access to storage devices through a native low level, block protocol.

15 FIGURE 3 is a block diagram of one embodiment of a storage network, indicated generally at 50, with a storage router that provides virtual local storage. Similar to that of FIGURE 2, storage network 50 includes a Fibre Channel high speed serial interconnect 52 and a
20 SCSI bus 54 bridged by a storage router 56. Storage router 56 of FIGURE 3 provides for a large number of workstations 58 to be interconnected on a common storage transport and to access common storage devices 60, 62 and 64 through native low level, block protocols.

25 According to the present invention, storage router 56 has enhanced functionality to implement security controls and routing such that each workstation 58 can have access to a specific subset of the overall data

stored in storage devices 60, 62 and 64. This specific subset of data has the appearance and characteristics of local storage and is referred to herein as virtual local storage. Storage router 56 allows the configuration and modification of the storage allocated to each attached workstation 58 through the use of mapping tables or other mapping techniques.

As shown in FIGURE 3, for example, storage device 60 can be configured to provide global data 65 which can be accessed by all workstations 58. Storage device 62 can be configured to provide partitioned subsets 66, 68, 70 and 72, where each partition is allocated to one of the workstations 58 (workstations A, B, C and D). These subsets 66, 68, 70 and 72 can only be accessed by the associated workstation 58 and appear to the associated workstation 58 as local storage accessed using native low level, block protocols. Similarly, storage device 64 can be allocated as storage for the remaining workstation 58 (workstation E).

Storage router 56 combines access control with routing such that each workstation 58 has controlled access to only the specified partition of storage device 62 which forms virtual local storage for the workstation 58. This access control allows security control for the specified data partitions. Storage router 56 allows this allocation of storage devices 60, 62 and 64 to be managed by a management station 76. Management station 76 can connect directly to storage router 56 via a direct

connection or, alternately, can interface with storage
router 56 through either Fibre Channel 52 or SCSI bus 54.
In the latter case, management station 76 can be a
workstation or other computing device with special rights
5 such that storage router 56 allows access to mapping
tables and shows storage devices 60, 62 and 64 as they
exist physically rather than as they have been allocated.

The environment of FIGURE 3 extends the concept of a
single workstation having locally connected storage
10 devices to a storage network 50 in which workstations 58
are provided virtual local storage in a manner
transparent to workstations 58. Storage router 56
provides centralized control of what each workstation 58
sees as its local drive, as well as what data it sees as
15 global data accessible by other workstations 58.
Consequently, the storage space considered by the
workstation 58 to be its local storage is actually a
partition (i.e., logical storage definition) of a
physically remote storage device 60, 62 or 64 connected
20 through storage router 56. This means that similar
requests from workstations 58 for access to their local
storage devices produce different accesses to the storage
space on storage devices 60, 62 and 64. Further, no
access from a workstation 58 is allowed to the virtual
25 local storage of another workstation 58.

The collective storage provided by storage devices
60, 62 and 64 can have blocks allocated by programming
means within storage router 56. To accomplish this

function, storage router 56 can include routing tables and security controls that define storage allocation for each workstation 58. The advantages provided by implementing virtual local storage in centralized storage devices include the ability to do collective backups and other collective administrative functions more easily. This is accomplished without limiting the performance of workstations 58 because storage access involves native low level, block protocols and does not involve the overhead of high level protocols and file systems required by network servers.

FIGURE 4 is a block diagram of one embodiment of storage router 56 of FIGURE 3. Storage router 56 can comprise a Fibre Channel controller 80 that interfaces with Fibre Channel 52 and a SCSI controller 82 that interfaces with SCSI bus 54. A buffer 84 provides memory work space and is connected to both Fibre Channel controller 80 and to SCSI controller 82. A supervisor unit 86 is connected to Fibre Channel controller 80, SCSI controller 82 and buffer 84. Supervisor unit 86 comprises a microprocessor for controlling operation of storage router 56 and to handle mapping and security access for requests between Fibre Channel 52 and SCSI bus 54.

FIGURE 5 is a block diagram of one embodiment of data flow within storage router 56 of FIGURE 4. As shown, data from Fibre Channel 52 is processed by a Fibre Channel (FC) protocol unit 88 and placed in a FIFO queue

90. A direct memory access (DMA) interface 92 then takes data out of FIFO queue 90 and places it in buffer 84. Supervisor unit 86 processes the data in buffer 84 as represented by supervisor processing 93. This processing
5 involves mapping between Fibre Channel 52 and SCSI bus 54 and applying access controls and routing functions. A DMA interface 94 then pulls data from buffer 84 and places it into a buffer 96. A SCSI protocol unit 98
10 pulls data from buffer 96 and communicates the data on SCSI bus 54. Data flow in the reverse direction, from SCSI bus 54 to Fibre Channel 52, is accomplished in a reverse manner.

The storage router of the present invention is a bridge device that connects a Fibre Channel link directly
15 to a SCSI bus and enables the exchange of SCSI command set information between application clients on SCSI bus devices and the Fibre Channel links. Further, the storage router applies access controls such that virtual
20 local storage can be established in remote SCSI storage devices for workstations on the Fibre Channel link. In one embodiment, the storage router provides a connection for Fibre Channel links running the SCSI Fibre Channel
25 Protocol (FCP) to legacy SCSI devices attached to a SCSI bus. The Fibre Channel topology is typically an Arbitrated Loop (FC_AL).

In part, the storage router enables a migration path to Fibre Channel based, serial SCSI networks by providing connectivity for legacy SCSI bus devices. The storage

router can be attached to a Fibre Channel Arbitrated Loop and a SCSI bus to support a number of SCSI devices. Using configuration settings, the storage router can make the SCSI bus devices available on the Fibre Channel
5 network as FCP logical units. Once the configuration is defined, operation of the storage router is transparent to application clients. In this manner, the storage router can form an integral part of the migration to new Fibre Channel based networks while providing a means to
10 continue using legacy SCSI devices.

In one implementation (not shown), the storage router can be a rack mount or free standing device with an internal power supply. The storage router can have a Fibre Channel and SCSI port, and a standard, detachable
15 power cord can be used, the FC connector can be a copper DB9 connector, and the SCSI connector can be a 68-pin type. Additional modular jacks can be provided for a serial port and a 802.3 10BaseT port, i.e. twisted pair Ethernet, for management access. The SCSI port of the
20 storage router can support SCSI direct and sequential access target devices and can support SCSI initiators, as well. The Fibre Channel port can interface to SCSI-3 FCP enabled devices and initiators.

To accomplish its functionality, one implementation
25 of the storage router uses: a Fibre Channel interface based on the HEWLETT-PACKARD TACHYON HPFC-5000 controller and a GLM media interface; an Intel 80960RP processor, incorporating independent data and program memory spaces,

and associated logic required to implement a stand alone processing system; and a serial port for debug and system configuration. Further, this implementation includes a SCSI interface supporting Fast-20 based on the SYMBIOS
5 53C8xx series SCSI controllers, and an operating system based upon the WIND RIVERS SYSTEMS VXWORKS or IXWORKS kernel, as determined by design. In addition, the storage router includes software as required to control basic functions of the various elements, and to provide
10 appropriate translations between the FC and SCSI protocols.

The storage router has various modes of operation that are possible between FC and SCSI target and initiator combinations. These modes are: FC Initiator to
15 SCSI Target; SCSI Initiator to FC Target; SCSI Initiator to SCSI Target; and FC Initiator to FC Target. The first two modes can be supported concurrently in a single storage router device are discussed briefly below. The third mode can involve two storage router devices
20 back to back and can serve primarily as a device to extend the physical distance beyond that possible via a direct SCSI connection. The last mode can be used to carry FC protocols encapsulated on other transmission technologies (e.g. ATM, SONET), or to act as a bridge
25 between two FC loops (e.g. as a two port fabric).

The FC Initiator to SCSI Target mode provides for the basic configuration of a server using Fibre Channel to communicate with SCSI targets. This mode requires

that a host system have an FC attached device and associated device drivers and software to generate SCSI-3 FCP requests. This system acts as an initiator using the storage router to communicate with SCSI target devices.

5 The SCSI devices supported can include SCSI-2 compliant direct or sequential access (disk or tape) devices. The storage router serves to translate command and status information and transfer data between SCSI-3 FCP and SCSI-2, allowing the use of standard SCSI-2 devices in a
10 Fibre Channel environment.

The SCSI Initiator to FC Target mode provides for the configuration of a server using SCSI-2 to communicate with Fibre Channel targets. This mode requires that a host system has a SCSI-2 interface and driver software to
15 control SCSI-2 target devices. The storage router will connect to the SCSI-2 bus and respond as a target to multiple target IDs. Configuration information is required to identify the target IDs to which the bridge will respond on the SCSI-2 bus. The storage router then
20 translates the SCSI-2 requests to SCSI-3 FCP requests, allowing the use of FC devices with a SCSI host system. This will also allow features such as a tape device acting as an initiator on the SCSI bus to provide full support for this type of SCSI device.

25 In general, user configuration of the storage router will be needed to support various functional modes of operation. Configuration can be modified, for example, through a serial port or through an Ethernet port via

SNMP (simple network management protocol) or a Telnet session. Specifically, SNMP manageability can be provided via an 802.3 Ethernet interface. This can provide for configuration changes as well as providing
5 statistics and error information. Configuration can also be performed via TELNET or RS-232 interfaces with menu driven command interfaces. Configuration information can be stored in a segment of flash memory and can be retained across resets and power off cycles. Password
10 protection can also be provided.

In the first two modes of operation, addressing information is needed to map from FC addressing to SCSI addressing and vice versa. This can be 'hard' configuration data, due to the need for address
15 information to be maintained across initialization and partial reconfigurations of the Fibre Channel address space. In an arbitrated loop configuration, user configured addresses will be needed for AL_PAs in order to insure that known addresses are provided between loop
20 reconfigurations.

With respect to addressing, FCP and SCSI 2 systems employ different methods of addressing target devices. Additionally, the inclusion of a storage router means that a method of translating device IDs needs to be
25 implemented. In addition, the storage router can respond to commands without passing the commands through to the opposite interface. This can be implemented to allow all generic FCP and SCSI commands to pass through the storage

router to address attached devices, but allow for configuration and diagnostics to be performed directly on the storage router through the FC and SCSI interfaces.

Management commands are those intended to be
5 processed by the storage router controller directly. This may include diagnostic, mode, and log commands as well as other vendor-specific commands. These commands can be received and processed by both the FCP and SCSI interfaces, but are not typically bridged to the opposite
10 interface. These commands may also have side effects on the operation of the storage router, and cause other storage router operations to change or terminate.

A primary method of addressing management commands though the FCP and SCSI interfaces can be through
15 peripheral device type addressing. For example, the storage router can respond to all operations addressed to logical unit (LUN) zero as a controller device. Commands that the storage router will support can include INQUIRY as well as vendor-specific management commands. These
20 are to be generally consistent with SCC standard commands.

The SCSI bus is capable of establishing bus connections between targets. These targets may internally address logical units. Thus, the prioritized
25 addressing scheme used by SCSI subsystems can be represented as follows: BUS:TARGET:LOGICAL UNIT. The BUS identification is intrinsic in the configuration, as a SCSI initiator is attached to only one bus. Target

addressing is handled by bus arbitration from information provided to the arbitrating device. Target addresses are assigned to SCSI devices directly, though some means of configuration, such as a hardware jumper, switch setting, or device specific software configuration. As such, the SCSI protocol provides only logical unit addressing within the Identify message. Bus and target information is implied by the established connection.

Fibre Channel devices within a fabric are addressed by a unique port identifier. This identifier is assigned to a port during certain well-defined states of the FC protocol. Individual ports are allowed to arbitrate for a known, user defined address. If such an address is not provided, or if arbitration for a particular user address fails, the port is assigned a unique address by the FC protocol. This address is generally not guaranteed to be unique between instances. Various scenarios exist where the AL-PA of a device will change, either after power cycle or loop reconfiguration.

The FC protocol also provides a logical unit address field within command structures to provide addressing to devices internal to a port. The FCP_CMD payload specifies an eight byte LUN field. Subsequent identification of the exchange between devices is provided by the FQXID (Fully Qualified Exchange ID).

FC ports can be required to have specific addresses assigned. Although basic functionality is not dependent on this, changes in the loop configuration could result

in disk targets changing identifiers with the potential risk of data corruption or loss. This configuration can be straightforward, and can consist of providing the device a loop-unique ID (AL_PA) in the range of "01h" to "EFh." Storage routers could be shipped with a default value with the assumption that most configurations will be using single storage routers and no other devices requesting the present ID. This would provide a minimum amount of initial configuration to the system administrator. Alternately, storage routers could be defaulted to assume any address so that configurations requiring multiple storage routers on a loop would not require that the administrator assign a unique ID to the additional storage routers.

Address translation is needed where commands are issued in the cases FC Initiator to SCSI Target and SCSI Initiator to FC Target. Target responses are qualified by the FQXID and will retain the translation acquired at the beginning of the exchange. This prevents configuration changes occurring during the course of execution of a command from causing data or state information to be inadvertently misdirected. Configuration can be required in cases of SCSI Initiator to FC Target, as discovery may not effectively allow for FCP targets to consistently be found. This is due to an FC arbitrated loop supporting addressing of a larger number of devices than a SCSI bus and the possibility of FC devices changing their AL-PA due to device insertion

or other loop initialization.

In the direct method, the translation to
BUS:TARGET:LUN of the SCSI address information will be
direct. That is, the values represented in the FCP LUN
5 field will directly map to the values in effect on the
SCSI bus. This provides a clean translation and does not
require SCSI bus discovery. It also allows devices to be
dynamically added to the SCSI bus without modifying the
address map. It may not allow for complete discovery by
10 FCP initiator devices, as gaps between device addresses
may halt the discovery process. Legacy SCSI device
drivers typically halt discovery on a target device at
the first unoccupied LUN, and proceed to the next target.
This would lead to some devices not being discovered.
15 However, this allows for hot plugged devices and other
changes to the loop addressing.

In the ordered method, ordered translation requires
that the storage router perform discovery on reset, and
collapses the addresses on the SCSI bus to sequential FCP
20 LUN values. Thus, the FCP LUN values 0-N can represent
N+1 SCSI devices, regardless of SCSI address values, in
the order in which they are isolated during the SCSI
discovery process. This would allow the FCP initiator
discovery process to identify all mapped SCSI devices
25 without further configuration. This has the limitation
that hot-plugged devices will not be identified until the
next reset cycle. In this case, the address may also be
altered as well.

In addition to addressing, according to the present invention, the storage router provides configuration and access controls that cause certain requests from FC Initiators to be directed to assigned virtual local storage partitioned on SCSI storage devices. For
5 example, the same request for LUN 0 (local storage) by two different FC Initiators can be directed to two separate subsets of storage. The storage router can use tables to map, for each initiator, what storage access is
10 available and what partition is being addressed by a particular request. In this manner, the storage space provided by SCSI storage devices can be allocated to FC initiators to provide virtual local storage as well as to create any other desired configuration for secured
15 access.

Although the present invention has been described in detail, it should be understood that various changes, substitutions, and alterations can be made hereto without departing from the spirit and scope of the invention as
20 defined by the appended claims.

WHAT IS CLAIMED IS:

1. A storage router for providing virtual local storage on remote SCSI storage devices to Fibre Channel devices, comprising:

5 a buffer providing memory work space for the storage router;

a Fibre Channel controller operable to connect to and interface with a Fibre Channel transport medium;

10 a SCSI controller operable to connect to and interface with a SCSI bus transport medium; and

a supervisor unit coupled to the Fibre Channel controller, the SCSI controller and the buffer, the supervisor unit operable:

15 to maintain a configuration for SCSI storage devices connected to the SCSI bus transport medium that maps between Fibre Channel devices and SCSI storage devices and that implements access controls for storage space on the SCSI storage devices; and

20 to process data in the buffer to interface between the Fibre Channel controller and the SCSI controller to allow access from Fibre Channel initiator devices to SCSI storage devices using native low level, block protocol in accordance with the configuration.

2. The storage router of Claim 1, wherein the configuration maintained by the supervisor unit includes an allocation of subsets of storage space to associated Fibre Channel devices, wherein each subset is only
5 accessible by the associated Fibre Channel device.

3. The storage router of Claim 2, wherein the Fibre Channel devices comprise workstations.

10 4. The storage router of Claim 2, wherein the SCSI storage devices comprise hard disk drives.

5. The storage router of Claim 1, wherein the Fibre Channel controller comprises:

15 a Fibre Channel (FC) protocol unit operable to connect to the Fibre Channel transport medium;

a first-in-first-out queue coupled to the Fibre Channel protocol unit; and

20 a direct memory access (DMA) interface coupled to the first-in-first-out queue and to the buffer.

6. The storage router of Claim 1, wherein the SCSI controller comprises:

25 a SCSI protocol unit operable to connect to the SCSI bus transport medium;

an internal buffer coupled to the SCSI protocol unit; and

a direct memory access (DMA) interface coupled to

the internal buffer and to the buffer of the storage router.

7. A storage network, comprising:

5 a Fibre Channel transport medium;
a SCSI bus transport medium;
a plurality of workstations connected to the Fibre Channel transport medium;
a plurality of SCSI storage devices connected to the
10 SCSI bus transport medium; and

a storage router interfacing between the Fibre Channel transport medium and the SCSI bus transport medium, the storage router providing virtual local storage on the SCSI storage devices to the workstations
15 and operable:

to map between the workstations and the SCSI storage devices;

to implement access controls for storage space on the SCSI storage devices; and

20 to allow access from the workstations to the SCSI storage devices using native low level, block protocol in accordance with the mapping and access controls.

25 8. The storage network of Claim 7, wherein the access controls include an allocation of subsets of storage space to associated workstations, wherein each subset is only accessible by the associated workstation.

9. The storage network of Claim 7, wherein the SCSI storage devices comprise hard disk drives.

5 10. The storage network of Claim 7, wherein the storage router comprises:

a buffer providing memory work space for the storage router;

10 a Fibre Channel controller operable to connect to and interface with a Fibre Channel transport medium, the Fibre Channel controller further operable to pull outgoing data from the buffer and to place incoming data into the buffer;

15 a SCSI controller operable to connect to and interface with a SCSI bus transport medium, the SCSI controller further operable to pull outgoing data from the buffer and to place incoming data into the buffer; and

20 a supervisor unit coupled to the Fibre Channel controller, the SCSI controller and the buffer, the supervisor unit operable:

25 to maintain a configuration for the SCSI storage devices that maps between Fibre Channel devices and SCSI storage devices and that implements the access controls for storage space on the SCSI storage devices; and

to process data in the buffer to interface between the Fibre Channel controller and the SCSI

controller to allow access from workstations to SCSI storage devices in accordance with the configuration.

11. A method for providing virtual local storage on
5 remote SCSI storage devices to Fibre Channel devices,
comprising:

interfacing with a Fibre Channel transport medium;
interfacing with a SCSI bus transport medium;
maintaining a configuration for SCSI storage devices
10 connected to the SCSI bus transport medium that maps
between Fibre Channel devices and the SCSI storage
devices and that implements access controls for storage
space on the SCSI storage devices; and

allowing access from Fibre Channel initiator devices
15 to SCSI storage devices using native low level, block
protocol in accordance with the configuration.

12. The method of Claim 11, wherein maintaining the
configuration includes allocating subsets of storage
20 space to associated Fibre Channel devices, wherein each
subset is only accessible by the associated Fibre Channel
device.

13. The method of Claim 12, wherein the Fibre
25 Channel devices comprise workstations.

14. The method of Claim 12, wherein the SCSI
storage devices comprise hard disk drives.

STORAGE ROUTER AND METHOD FOR
PROVIDING VIRTUAL LOCAL STORAGE

5 ABSTRACT OF THE DISCLOSURE

 A storage router (56) and storage network (50) provide virtual local storage on remote SCSI storage devices (60, 62, 64) to Fibre Channel devices. A plurality of Fibre Channel devices, such as workstations
10 (58), are connected to a Fibre Channel transport medium (52), and a plurality of SCSI storage devices (60, 62, 64) are connected to a SCSI bus transport medium (54). The storage router (56) interfaces between the Fibre
15 Channel transport medium (52) and the SCSI bus transport medium (54). The storage router (56) maps between the workstations (58) and the SCSI storage devices (60, 62, 64) and implements access controls for storage space on the SCSI storage devices (60, 62, 64). The storage
20 router (56) then allows access from the workstations (58) to the SCSI storage devices (60, 62, 64) using native low level, block protocol in accordance with the mapping and the access controls.

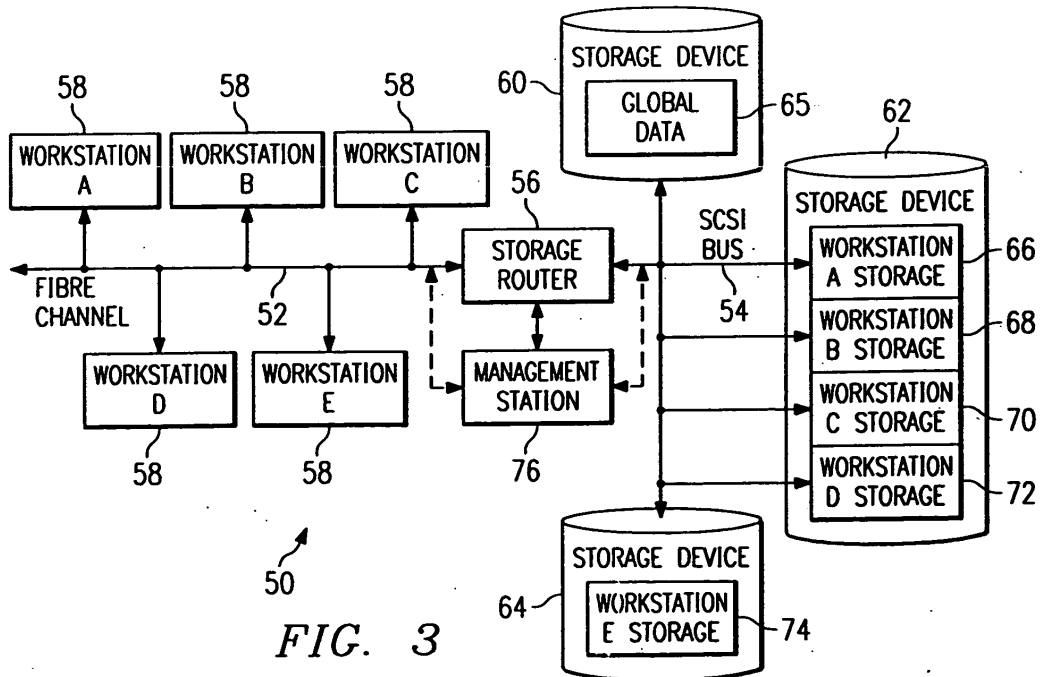
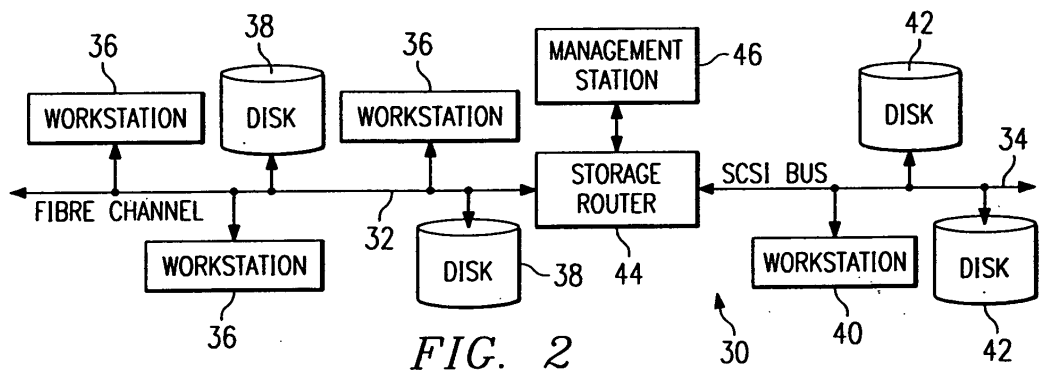
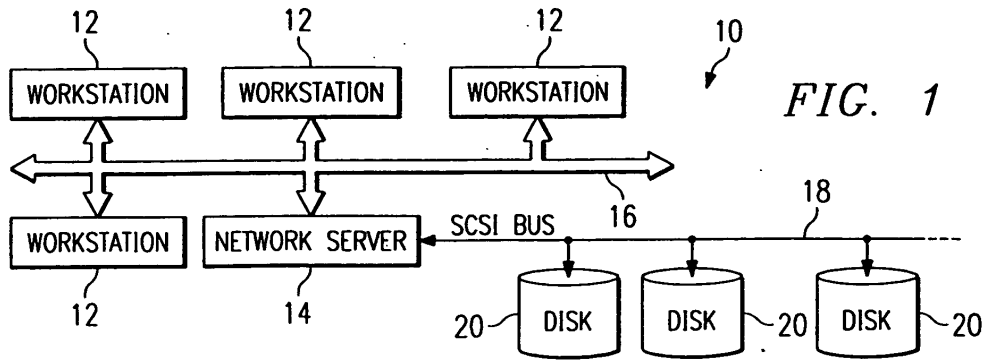

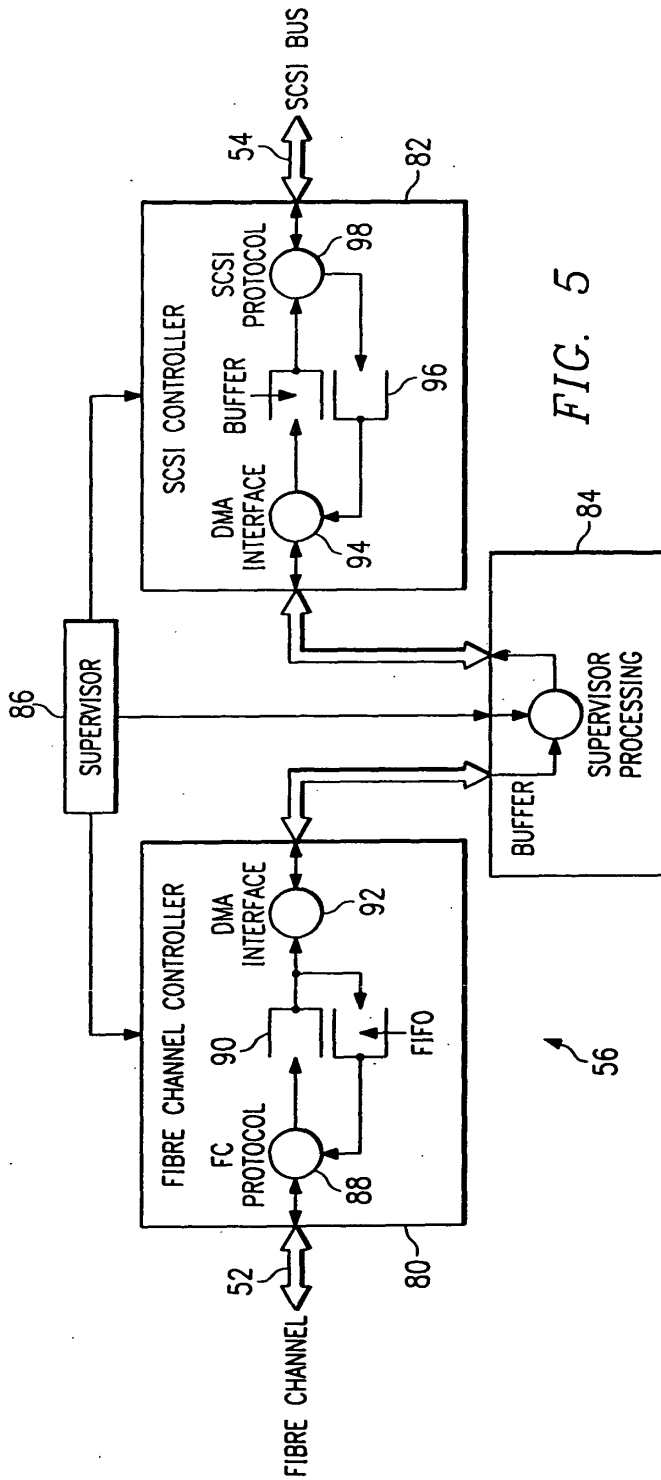
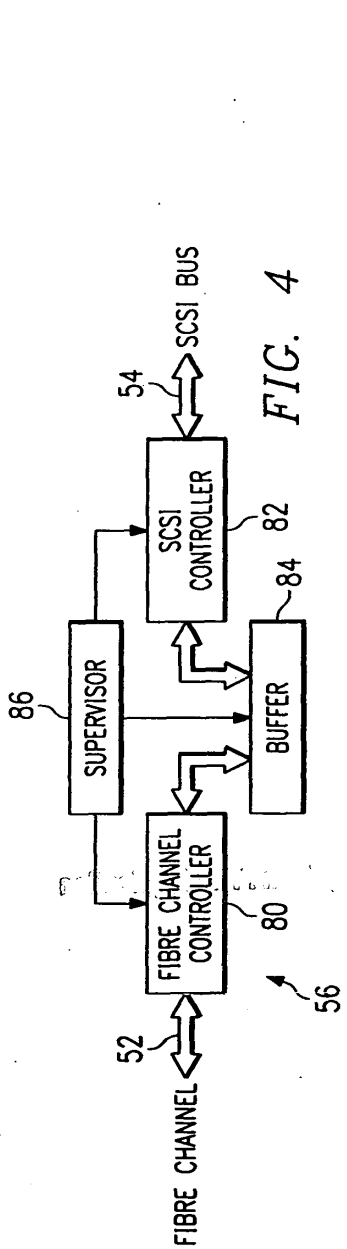

Copy from Prior Application

DECLARATION AND POWER OF ATTORNEY

As the below named inventor, I declare that:

My residence, post office address and citizenship are as stated below next to my name, that I believe I am the original, first and joint inventor of the subject matter which is claimed and for which a patent is sought on the invention or design entitled STORAGE ROUTER AND METHOD FOR PROVIDING VIRTUAL LOCAL STORAGE, the specification of which (check one):

 X is attached hereto; or

 was filed on as

Application Serial No. and was

amended on (if applicable);

that I have reviewed and understand the contents of the above-identified specification, including the claims, as amended by any amendment referred to above; and that I acknowledge the duty to disclose to the U.S. Patent and Trademark Office all information known to me to be material to patentability as defined in 37 C.F.R. § 1.56.

I hereby claim foreign priority benefits under 35 U.S.C. § 119 of any foreign application(s) for patent or inventor's certificate listed below and have also identified below any foreign application(s) for patent or inventor's certificate having a filing date before that of the application on which priority is claimed:

<u>Number</u>	<u>Country</u>	<u>Date Filed</u>	<u>Priority Claimed (Yes) (No)</u>
None.			

I hereby claim the benefit under 35 U.S.C. § 120 of any United States application(s) listed below and, insofar as the subject matter of each of the claims of this application is not disclosed in the prior United States application(s) in the manner provided by the first paragraph of 35 U.S.C. § 112, I acknowledge the duty to disclose to the U.S. Patent and Trademark Office all information known to me to be material to patentability as defined in 37 C.F.R. § 1.56 which became available between the filing date of the prior application(s) and the national or PCT international filing date of this application:

<u>Application</u> <u>Serial Number</u>	<u>Date Filed</u>	<u>Status</u>
--	-------------------	---------------

None.

I hereby appoint:

Jerry W. Mills	Reg. No. 23,005
Robert M. Chiaviello, Jr.	Reg. No. 32,461
Ann C. Livingston	Reg. No. 32,479
William N. Hulsey III	Reg. No. 33,402
Thomas R. Felger	Reg. No. 28,842
Charles S. Fish	Reg. No. 35,870
Wei Wei Jeang	Reg. No. 33,305
Kevin J. Meek	Reg. No. 33,738
Anthony E. Peterman	Reg. No. 38,270
Barton E. Showalter	Reg. No. 38,302
David G. Wille	Reg. No. 38,363
Philip W. Woo	Reg. No. 39,880
Bradley P. Williams	Reg. No. 40,227
Terry J. Stalford	Reg. No. 39,522
Christopher W. Kennerly	Reg. No. 40,675
Daniel P. Stewart	Reg. No. 41,332
Roger J. Fulghum	Reg. No. 39,678
Rodger L. Tate	Reg. No. 27,399
Scott F. Partridge	Reg. No. 28,142
James B. Arpin	Reg. No. 33,470
James Remenick	Reg. No. 36,902

Jay B. Johnson	Reg. No. 38,193
Christopher C. Campbell	Reg. No. 37,291
Stacy B. Margolies	Reg. No. 39,760
Robert W. Holland	Reg. No. 40,020
Steven R. Sprinkle	Reg. No. 40,825

all of the firm of Baker & Botts, L.L.P., my attorneys with full power of substitution and revocation, to prosecute this application and to transact all business in the United States Patent and Trademark Office connected therewith, and to file and prosecute any international patent applications filed thereon before any international authorities.

Send Correspondence To:

Baker & Botts, L.L.P.
2001 Ross Avenue
Dallas, Texas 75201-2980

Direct Telephone Calls To:

Anthony E. Peterman
at (512) 322-2599
Atty. Docket No.064113.0103

I declare that all statements made herein of my own knowledge are true and that all statements made on information and belief are believed to be true; and further that these statements were made with the knowledge that willful false statements and the like so made are punishable by fine or imprisonment, or both, under Section 1001 of Title 18 of the United States Code, and that such willful false statements may jeopardize the validity of the application or any patent issuing thereon.

Full name of the first inventor

Geoffrey B. Hoese

Inventor's signature

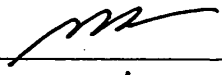

Date

12/22/97

Residence (City, County, State)

Austin, Travis County,
Texas

Citizenship

United States of America

Post Office Address

1904 Ann Arbor Avenue
Austin, Texas 78704

Full name of the second inventor

Jeffry T. Russell

Inventor's signature

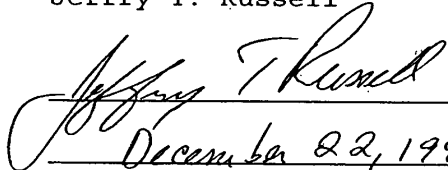

Date

December 22, 1997

Residence (City, County, State)

Cibolo, Guadalupe County,
Texas

Citizenship

United States of America

Post Office Address

205 Kariba Cove
Cibolo, Texas 78108

FORM PTO-1595
1-31-92

RECORDATION FORM COVER SHEET
PATENTS ONLY

U.S. DEPARTMENT OF COMMERCE
Patent and Trademark Office

To the Honorable Commissioner of Patents and Trademarks. Please record the attached original documents or copy thereof.

1. Name and Address of Conveying Party(ies):
Geoffrey B. Hoese
1904 Ann Arbor Avenue
Austin, Texas 78704
 Individual/Citizenship: United States of America
Additional name(s) of conveying party(ies) attached?
 Yes No

2. Name and Address of receiving Party(ies):
Name: Crossroads Systems, Inc.
Internal Address: Suite II-300
Street Address: 9390 Research Blvd.
City: Austin
State/Zip: Texas 78759
 Corporation/State Texas
Additional name(s) & address(es) attached? Yes No

3. Nature of conveyance:
 Assignment Merger
 Security Agreement Change of Name
 Other
Execution Date: December 22, 1997

4. Application number(s) or patent number(s):
If this document is being filed together with a new application, the execution date of the application is: December 22, 1997
A. Additional Numbers attached? Yes No
B. Patent No.(s) Yes No

5. Name and address of party to whom correspondence concerning document should be mailed:
Name: Anthony E. Peterman
Internal Address: Baker & Botts, L.L.P.
Street Address: 2001 Ross Avenue
City/State/Zip: Dallas, Texas 75201-2980

6. Total number of applications and patents involved: 1
7. Total Fee (37 CFR 3.41): \$40.00
 Enclosed
 Authorized to be charged to deposit account
8. Deposit account number:
(Attach Duplicate Copy of this page if paying by deposit account)

DO NOT USE THIS SPACE

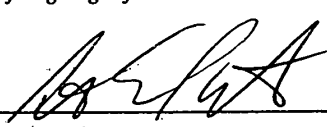
9. Statement and signature.
To the best of my knowledge and belief, the foregoing information is true and correct and any attached copy is a true copy of the original document.
Anthony E. Peterman  December 31, 1997
Name of Person Signing Signature Date
Total number of pages including cover sheet 4

OMB No. 0651-0011 (exp.4/94)
Do not detach this portion

Mail documents to be recorded with required cover sheet information:
Commissioner of Patent and Trademarks **Copy from Prior Application**
Box Assignments
Washington, D.C. 20231
Public burden reporting for this sample cover sheet is estimated to average about 30 minutes per document to be recorded, including time for reviewing the document and gathering the data needed, and completing and reviewing the sample cover sheet. Send comments regarding this burden estimate to the U.S. Patent and Trademark Office, Office of Information Systems, PK2-1000C, Washington, D.C. 20231, and to the Office of Management and Budget, Paperwork Reduction Project, (0651-0011), Washington, D.C. 20503.

U.S. Patent and Trademark Office

Recordation Form Cover Sheet -Form PTO-1595 (01/31/92)

Patents Only

Page 2

Attorneys Docket: 064113.0103

Section 1 -Name of conveying parties

Additional names (individual)

Jeffry T. Russell

205 Kariba Cove

Cibolo, Texas 78108

United States of America

ASSIGNMENT

WHEREAS, we, the undersigned inventors of residence as listed, have invented certain new and useful improvements as below entitled, for which application for United States Letters Patent is made, said application having been executed on the date set forth below; and

WHEREAS, Crossroads Systems, Inc. (hereinafter referred to as "Assignee"), a Texas corporation, with its principal address at 9390 Research Blvd., Suite II-300, Austin, Texas 78759, desires to acquire our entire right, title and interest in and to the invention, and in and to the said application and any Letters Patent that may issue thereon;

NOW, THEREFORE, for good and valuable consideration, the receipt and sufficiency of which is hereby acknowledged, we assign to Assignee, all right, title and interest in and to the said invention and in and to the said application and all patents which may be granted therefor, and all divisions, reissues, continuations, continuations-in-part and extensions thereof; and we authorize and request the Commissioner of Patents and Trademarks to issue all patents for said invention, or patents resulting therefrom, insofar as our interests are concerned, to Assignee.

We also assign to Assignee, all right, title and interest in and to the invention disclosed in said application throughout the world, including the right to file applications and obtain patents, utility models, industrial models and designs for said invention in its own name throughout the world, including all rights to publish cautionary notices reserving ownership of said invention and all rights to register said invention in appropriate registries; and we further agree to execute any and all powers of attorney, applications, assignments, declarations, affidavits, and any other papers in connection therewith necessary to perfect such right, title and interest in Assignee.

We will communicate to Assignee any facts known to us respecting any improvements; and, at the expense of Assignee, we will testify in any legal proceedings, sign all lawful papers, execute all divisional, continuation, continuation-in-part, reissue and substitute applications, make lawful oaths and declarations, and generally do everything possible to vest title in Assignee and to aid Assignee to obtain and enforce proper protection for said invention in all countries.

This Assignment shall be binding on the parties' successors, assigns and legal representatives.

Title of Invention: STORAGE ROUTER AND METHOD FOR PROVIDING VIRTUAL LOCAL STORAGE

Signature of first Inventor:
Inventor's Name:



Geoffrey B. Hoese

Residence (City, County, State)

Austin, Travis County,
Texas

Date:

12/22/97

Date Application Executed:

12/22/97

Signature of second Inventor:
Inventor's Name:

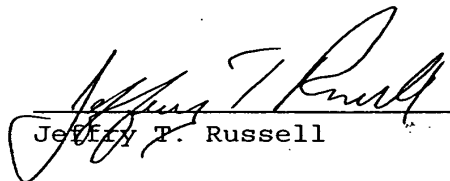

Jeffrey P. Russell

Residence (City, County, State)

Cibolo, Guadalupe County,
Texas

Date:

December 22, 1997

Date Application Executed:

December 22, 1997

IN THE UNITED STATES PATENT AND TRADEMARK OFFICE

In the Application of: Geoffrey B. Hoese, et al.
Serial No. 09/001,799
Filing Date: December 31, 1997
Group Art No. Unknown
Title STORAGE ROUTER AND METHOD FOR PROVIDING
VIRTUAL LOCAL STORAGE

Copy from Prior Application

Assistant Commissioner of Patents
Washington, D.C. 20231

CERTIFICATION UNDER 37 CFR §1.8

I hereby certify that this documents is being deposited in the United States Postal Service as first class mail on the date identified below in an envelope addressed to: Assistant Commissioner for Patents, Washington, D.C. 20231

Rebecca Morrison

Rebecca Morrison

4-15-98

Date

REVOCATION OF POWER OF ATTORNEYS

AND

POWER OF ATTORNEY AND CHANGE OF MAILING ADDRESS

Sir:

Crossroads Systems, Inc., which is the assignee of record of 100% of the right, title and interest in the above-identified application, as evidenced by the Assignment enclosed herewith, hereby revokes all previous Powers of Attorney and appoints the following attorneys, all of the firm of Gray Cary Ware & Freidenrich, LLP, to prosecute the above-identified patent application and to transact all business in the Patent and Trademark Office connected therewith.

WILLIAM N. HULSEY III
STEPHEN E. REITER
GREGORY P. RAYMER
DAVID F. KLEINSMITH
BARRY N. YOUNG
TIMOTHY W. LOHSE
STANLEY H. KIM

Registration No. 33,402
Registration No. 31,192
Registration No. 36,647
Registration No. 40,050
Registration No. 27,774
Registration No. 35,255
Registration No. 40,047

Applicant(s): Geoffrey B. Hoese, et al.
Serial No.: 09/001799
Filed: December 31, 1997
Page 2

PATENT
Attorney Docket No.: 103671.991120
(formerly 064113.0103)

MARNIE WRIGHT BARNHORST
DARLENE W. HAYES
RAMSEY R. STEWART
STEVEN R. SPRINKLE
MICHAEL A. HOFF

Registration No. 36,740
Registration No. 33,899
Registration No. 38,322
Registration No. 40,825
Registration No. 40,018

We hereby state that we have reviewed and understand the contents of the above-identified specification, including the claims, as amended by any amendment(s) referred to above.

We acknowledge the duty to disclose information which is material to the examination of this application in accordance with Title 37, Code of Federal Regulations, § 1.56(a).

Direct all telephone calls to WILLIAM N. HULSEY III at (512)
457-7040.

Address all correspondence to:

William N. Hulsey III
GARY CARY WARE & FREIDENRICH, LLP
100 Congress Avenue, Suite 1440
Austin, Texas 78701

Respectfully submitted,

CROSSROADS SYSTEMS, INC.

By: 

Brian R. Smith

Chief Technical Officer

Date: 

AU4001078.1
103671-991120

FORM PTO-1595
1-31-92

RECORDATION FORM COVER SHEET
PATENTS ONLY

U.S. DEPARTMENT OF COMMERCE
Patent and Trademark Office

To the Honorable Commissioner of Patents and Trademarks. Please record the attached original documents or copy thereof.

1. Name and Address of Conveying Party(ies):
Geoffrey B. Hoese
1904 Ann Arbor Avenue
Austin, Texas 78704
 Individual/Citizenship: United States of America
Additional name(s) of conveying party(ies) attached?
 Yes No

2. Name and Address of receiving Party(ies):
Name: Crossroads Systems, Inc.
Internal Address: Suite II-300
Street Address: 9390 Research Blvd.
City: Austin
State/Zip: Texas 78759
 Corporation/State Texas
Additional name(s) & address(es) attached? Yes No

3. Nature of conveyance:
 Assignment Merger
 Security Agreement Change of Name
 Other
Execution Date: December 22, 1997

4. Application number(s) or patent number(s):
If this document is being filed together with a new application, the execution date of the application is: December 22, 1997
A. Additional Numbers attached? Yes No
B. Patent No.(s) Yes No

5. Name and address of party to whom correspondence concerning document should be mailed:
Name: Anthony E. Peterman
Internal Address: Baker & Botts, L.L.P.
Street Address: 2001 Ross Avenue
City/State/Zip: Dallas, Texas 75201-2980

6. Total number of applications and patents involved: 1
7. Total Fee (37 CFR 3.41): \$40.00
 Enclosed
 Authorized to be charged to deposit account
8. Deposit account number:
(Attach Duplicate Copy of this page if paying by deposit account)

DO NOT USE THIS SPACE

9. Statement and signature.
To the best of my knowledge and belief, the foregoing information is true and correct and any attached copy is a true copy of the original document.

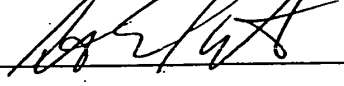
Anthony E. Peterman  December 31, 1997
Name of Person Signing Signature Date

Total number of pages including cover sheet 4

OMB No. 0651-0011 (exp.4/94)

Do not detach this portion

Mail documents to be recorded with required cover sheet information:
Commissioner of Patent and Trademarks
Box Assignments
Washington, D.C. 20231

Public burden reporting for this sample cover sheet is estimated to average about 30 minutes per document to be recorded, including time for reviewing the document and gathering the data needed, and completing and reviewing the sample cover sheet. Send comments regarding this burden estimate to the U.S. Patent and Trademark Office, Office of Information Systems, PK2-1000C, Washington, D.C. 20231, and to the Office of Management and Budget, Paperwork Reduction Project, (0651-0011), Washington, D.C. 20503.

U.S. Patent and Trademark Office

Recordation Form Cover Sheet -Form PTO-1595 (01/31/92)

Patents Only

Page 2

Attorneys Docket: 064113.0103

Section 1 -Name of conveying parties

Additional names (individual)

Jeffry T. Russell
205 Kariba Cove
Cibolo, Texas 78108

United States of America

ASSIGNMENT

WHEREAS, we, the undersigned inventors of residence as listed, have invented certain new and useful improvements as below entitled, for which application for United States Letters Patent is made, said application having been executed on the date set forth below; and

WHEREAS, Crossroads Systems, Inc. (hereinafter referred to as "Assignee"), a Texas corporation, with its principal address at 9390 Research Blvd., Suite II-300, Austin, Texas 78759, desires to acquire our entire right, title and interest in and to the invention, and in and to the said application and any Letters Patent that may issue thereon;

NOW, THEREFORE, for good and valuable consideration, the receipt and sufficiency of which is hereby acknowledged, we assign to Assignee, all right, title and interest in and to the said invention and in and to the said application and all patents which may be granted therefor, and all divisions, reissues, continuations, continuations-in-part and extensions thereof; and we authorize and request the Commissioner of Patents and Trademarks to issue all patents for said invention, or patents resulting therefrom, insofar as our interests are concerned, to Assignee.

We also assign to Assignee, all right, title and interest in and to the invention disclosed in said application throughout the world, including the right to file applications and obtain patents, utility models, industrial models and designs for said invention in its own name throughout the world, including all rights to publish cautionary notices reserving ownership of said invention and all rights to register said invention in appropriate registries; and we further agree to execute any and all powers of attorney, applications, assignments, declarations, affidavits, and any other papers in connection therewith necessary to perfect such right, title and interest in Assignee.

We will communicate to Assignee any facts known to us respecting any improvements; and, at the expense of Assignee, we will testify in any legal proceedings, sign all lawful papers, execute all divisional, continuation, continuation-in-part, reissue and substitute applications, make lawful oaths and declarations, and generally do everything possible to vest title in Assignee and to aid Assignee to obtain and enforce proper protection for said invention in all countries.

This Assignment shall be binding on the parties' successors, assigns and legal representatives.

Title of Invention: STORAGE ROUTER AND METHOD FOR PROVIDING VIRTUAL LOCAL STORAGE

Signature of first Inventor:

Inventor's Name:

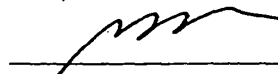

Geoffrey B. Hoese

Residence (City, County, State)

Austin, Travis County,
Texas

Date:

12/22/97

Date Application Executed:

12/22/97

Signature of second Inventor:

Inventor's Name:

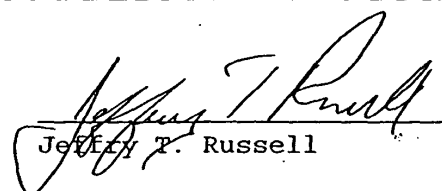

Jeffrey T. Russell

Residence (City, County, State)

Cibolo, Guadalupe County,
Texas

Date:

December 22, 1997

Date Application Executed:

December 22, 1997

IN THE UNITED STATES PATENT AND TRADEMARK OFFICE	
PRELIMINARY AMENDMENT	Atty. Docket No. CROSS1120-13
Applicants: Goeffrey B. Hoese, et al.	
Application Number Unknown	Filed September 9, 2003
For: Storage Router and Method for Providing Virtual Local Storage	
Group Art Unit Unknown	Confirmation Number: Unknown

Mail Stop: Patent Application
 Commissioner for Patents
 Alexandria, VA 22313

<u>Certification Under 37 C.F.R. §1.10</u>
I hereby certify that this document is being deposited with the United States Postal Service as Express Mail to Addressee in an envelope addressed to: Mail Stop: Patent Application, Commissioner for Patents, Alexandria, VA 22313 on September 9, 2003 .
<i>Janice Pampell</i> Janice Pampell

Dear Sir:

Please amend the application as follows:

IN THE SPECIFICATION

Following the title, please insert the following paragraph:

RELATED APPLICATIONS

This application is a continuation of and claims the benefit of the filing dates of U.S. Patent Application Serial No. 10/081,110 by inventors Geoffrey B. Hoese and Jeffry T. Russell, entitled "Storage Router and Method for Providing Virtual Local Storage" filed on February 22, 2002 which in turn is a continuation of U.S. Application No. 09/354,682 by inventors Geoffrey B. Hoese and Jeffry T. Russell, entitled "Storage Router and Method for Providing Virtual Local Storage" filed on July 15, 1999, now U.S. Patent No. 6,421,753, which in turn is a continuation of U.S. Patent Application Serial No. 09/001,799, filed on December 31, 1997, now U.S. Patent No. 5,941,972, and hereby incorporates these applications by reference in their entireties as if they had been fully set forth herein.

IN THE CLAIMS

1-14 Cancelled

15. (New) A storage router for providing virtual local storage on remote storage devices to a device, comprising:
a buffer providing memory work space for the storage router;
a first Fibre Channel controller operable to connect to and interface with a first Fibre Channel transport medium;
a second Fibre Channel controller operable to connect to and interface with a second Fibre Channel transport medium; and
a supervisor unit coupled to the first and second Fibre Channel controllers and the buffer, the supervisor unit operable:
to maintain a configuration for remote storage devices connected to the second Fibre Channel transport medium that maps between the device and the remote storage devices and that implements access controls for storage space on the remote storage devices; and
to process data in the buffer to interface between the first Fibre Channel controller and the second Fibre Channel controller to allow access from Fibre Channel initiator devices to the remote storage devices using native low level, block protocol in accordance with the configuration.

16. (New) The storage router of claim 15, wherein the configuration maintained by the supervisor unit includes an allocation of subsets of storage space to associated Fibre Channel devices, wherein each subset is only accessible by the associated Fibre Channel device.

17. (New) The storage router of claim 16, wherein the Fibre Channel devices comprise workstations.

18. (New) The storage router of claim 16, wherein the remote storage devices comprise hard disk drives.

19. (New) The storage router of claim 15, wherein each of the first Fibre Channel

controller comprises:

- a Fibre Channel (FC) protocol unit operable to connect to the Fibre Channel transport medium;
- a first-in-first-out queue coupled to the Fibre Channel protocol unit; and
- a direct memory access (DMA) interface coupled to the first-in-first-out queue and to the buffer.

20. (New) A storage network, comprising:
a first Fibre Channel transport medium;
a second Fibre Channel transport medium;
a plurality of workstations connected to the first Fibre Channel transport medium;
a plurality of storage devices connected to the second Fibre Channel transport medium;

and

a storage router interfacing between the first Fibre Channel transport medium and the second Fibre Channel transport medium, the storage router providing virtual local storage on the storage devices to the workstations and operable:

to map between the workstations and the storage devices;
to implement access controls for storage space on the storage devices; and
to allow access from the workstations to the storage devices using native low level, block protocol in accordance with the mapping and access controls.

21. (New) The storage network of claim 20, wherein the access controls include an allocation of subsets of storage space to associated workstations, wherein each subset is only accessible by the associated workstation.

22. (New) The storage network of claim 20, wherein the storage devices comprise hard disk drives.

23. (New) The storage network of claim 20, wherein the storage router comprises:
a buffer providing memory work space for the storage router;
a first Fibre Channel controller operable to connect to and interface with the first Fibre Channel transport medium, the first Fibre Channel controller further operable to pull outgoing data from the buffer and to place incoming data into the buffer;

a second Fibre Channel controller operable to connect to and interface with the second Fibre Channel transport medium, the second Fibre Channel controller further operable to pull outgoing data from the buffer and to place incoming data into the buffer; and

a supervisor unit coupled to the first and second Fibre Channel controllers and the buffer, the supervisor unit operable:

to maintain a configuration for the storage devices that maps between workstations and storage devices and that implements the access controls for storage space on

the storage devices; and

to process data in the buffer to interface between the first Fibre Channel controller and the second Fibre Channel controller to allow access from workstations to storage devices in accordance with the configuration.

24. (New) A method for providing virtual local storage on remote storage devices to Fibre Channel devices, comprising:

interfacing with a first Fibre Channel transport medium;

interfacing with a second Fibre Channel transport medium;

maintaining a configuration for remote storage devices connected to the second Fibre Channel transport medium that maps between Fibre Channel devices and the remote storage devices and that implements access controls for storage space on the remote storage devices; and

allowing access from Fibre Channel initiator devices to the remote storage devices using native low level, block protocol in accordance with the configuration.

25. (New) The method of claim 24, wherein maintaining the configuration includes allocating subsets of storage space to associated Fibre Channel devices, wherein each subset is only accessible by the associated Fibre Channel device.

26. (New) The method of claim 25, wherein the Fibre Channel devices comprise workstations.

27. (New) The method of claim 25, wherein the remote storage devices comprise hard disk drives.

28. (New) An apparatus for providing virtual local storage on a remote storage device to a device operating according to a Fibre Channel protocol, comprising:

a first controller operable to connect to and interface with a first transport medium, wherein the first transport medium is operable according to the Fibre Channel protocol;

a second controller operable to connect to and interface with a second transport medium, wherein the second transport medium is operable according to the Fibre Channel protocol; and

a supervisor unit coupled to the first controller and the second controller, the supervisor unit operable to control access from the device connected to the first transport medium to the remote storage device connected to the second transport medium using native low level, block protocols according to a map between the device and the remote storage device.

29. (New) The apparatus of Claim 28, wherein the supervisor unit is further operable to maintain a configuration wherein the configuration includes the map between the device and the remote storage device, and further wherein the map includes virtual LUNs that provide a representation of the storage device.

30. (New) The apparatus of Claim 29, wherein the map only exposes the device to LUNs that the device may access.

31. (New) The apparatus of Claim 28, wherein the supervisor unit is further operable to maintain a configuration including the map, wherein the map provides a mapping from a host device ID to a virtual LUN representation of the remote storage device to a physical LUN of the remote storage device.

32. (New) The apparatus of Claim 28, wherein the remote storage device further comprises storage space partitioned into virtual local storage for the device connected to the first transport medium.

33. (New) The apparatus of Claim 32, wherein the supervisor unit is further operable to prevent the device from accessing any storage on the remote storage device that is not part of a virtual local storage partition assigned to the device

34. (New) The apparatus of Claim 28, wherein the first controller and the second controller further comprise a single controller.

35. (New) A system for providing virtual local storage on remote storage devices, comprising:

- a first controller operable to connect to and interface with a first transport medium operable according to a Fibre Channel protocol;
- a second controller operable to connect to and interface with a second transport medium operable according to the Fibre Channel protocol;
- at least one device connected to the first transport medium;
- at least one storage device connected to the second transport medium; and
- an access control device coupled to the first controller and the second controller, the access control device operable to:
 - map between the at least one device and a storage space on the at least one storage device; and
 - control access from the at least one device to the at least one storage device using native low level, block protocol in accordance with the map.

36. (New) The system of Claim 35, wherein the access control device is further operable to maintain a configuration wherein the configuration includes the map between the at least one device and the at least one storage device, and further wherein the map includes virtual LUNs that provide a representation of the at least one storage device.

37. (New) The system of Claim 36, wherein the map only exposes the at least one device to LUNs that the at least one device may access.

38. (New) The system of Claim 35, wherein the access control device is further operable to maintain a configuration including the map, wherein the map provides a mapping from a host device ID to a virtual LUN representation of the at least one storage device to a physical LUN of the at least one storage device.

39. (New) The system of Claim 35, wherein the at least one storage device further comprises storage space partitioned into virtual local storage for the at least one device.

40. (New) The system of Claim 39, wherein the access control unit is further operable to prevent at least one device from accessing any storage on the at least one storage device that is not part of a virtual local storage partition assigned to the at least one device.

41. (New) The system of Claim 35, wherein the first controller and the second controller further comprise a single controller.

42. (New) A method for providing virtual local storage on remote storage devices, comprising:

mapping between a device connected to a first transport medium and a storage device connected to a second transport medium, wherein the first transport medium and the second transport medium operate according to a Fibre Channel protocol;

implementing access controls for storage space on the storage device; and

allowing access from the device connected to the first transport medium to the storage device using native low level, block protocols.

43. (New) The method of Claim 42, further comprising maintaining a configuration wherein the configuration includes a map between the device and the one storage device, and further wherein the map includes virtual LUNs that provide a representation of the storage device.

44. (New) The method of Claim 43, wherein the map only exposes the device to LUNs that the device may access.

45. (New) The method of Claim 42, further comprising maintaining a configuration including a map from a host device ID to a virtual LUN representation of the storage device to a physical LUN of the storage device.

46. (New) The method of Claim 42, further comprising partitioning storage space on the storage device into virtual local storage for the device.

47. (New) The method of Claim 46, further comprising preventing the device from accessing any storage on the storage device that is not part of a virtual local storage partition assigned to the device.

48. (New) A system for providing virtual local storage, comprising:
a host device;
a storage device remote from the host device, wherein the storage device has a storage space;
a first controller;

a second controller
a first transport medium operable according to a Fibre Channel protocol, wherein the first transport medium connects the host device to the first controller;
a second transport medium operable according to the Fibre Channel protocol, wherein the second transport medium connects the second controller to the storage device;
a supervisor unit coupled to the first controller and the second controller, the supervisor unit operable to:
maintain a configuration that maps between the host device and at least a portion of the storage space on the storage device; and
implement access controls according to the configuration for the storage space on the storage device using native low level, block protocol.

49. (New) The system of Claim 48, wherein the supervisor unit is further operable to:
maintain a configuration that maps from the host device to a virtual representation of at least a portion of the storage space on the storage device to the storage device; and
allow the host device to access only that portion of the storage space that is contained in the map.

50. (New) The system of Claim 49, wherein the configuration comprises a map from a host device ID to a virtual LUN representation of the storage device to a physical LUN of the storage device.

51. (New) The system of Claim 48, wherein the storage device further comprises storage space partitioned into virtual local storage for the host device.

52. (New) The system of Claim 51, wherein the supervisor unit is further operable to prevent the host device from accessing any storage on the storage device that is not part of a virtual local storage partition assigned to the host device.

53. (New) The apparatus of Claim 48, wherein the first controller and the second controller further comprise a single controller.

REMARKS

Applicants appreciate the time taken by the Examiner to review Applicants' present application.

Applicant has made an earnest attempt to place this case in condition for allowance. For the foregoing reasons, Applicant respectfully requests full allowance of Claims 15-53.

The Director of the USPTO is hereby authorized to charge any deficiencies or credit any overpayment to Deposit Account No. 50-0456 of Gray Cary Ware & Freidenrich LLP.

Respectfully submitted,

Gray Cary Ware & Freidenrich LLP



John L. Adair
Reg. No. 48,828

Dated: September 1, 2003

1221 South MoPac Expressway
Suite 400
Austin, TX 78746-6875
Tel. (512) 457-7142
Fax. (512) 457-7001



Patent and Trademark Office
 Address: COMMISSIONER OF PATENTS AND TRADEMARKS
 Washington, D.C. 20231

SERIAL NUMBER	FILING DATE	FIRST NAMED APPLICANT	ATTORNEY DOCKET NO.
09/001799	12/31/97	HOESE	064113.0103

EXAMINER
 CHAN, EDDIE

BAKER AND BOTTS
 2001 ROSS AVENUE
 DALLAS TX 75201-2980

ART UNIT	PAPER NUMBER
2751	3

DATE MAILED: 07/10/98

This is in response to the Power of Attorney filed 04/20/98

- 1. The Power of Attorney to you in this application **has been revoked** by the applicant. Future correspondence will be mailed to the new address of record. 37 CFR 1.33.
- 2. The Power of Attorney to you in this application **has been revoked** by the assignee who has intervened as provided by 37 CFR 3.71. Future correspondence will be mailed to the new address of record. (37 CFR 1.33).
- 3. The withdrawal as attorney in this application **has been accepted**. Future correspondence will be mailed to the new address of record. 37 CFR 1.33.

Kim Blatton 7133064139
 This is a communication from the
 Patent and Trademark Office

Copy from Prior Application

- 4. The Power of Attorney in this application **is accepted**. Correspondence in this application will be mailed to the below-noted address as provided by 37 CFR 1.33.
- 5. The Power of Attorney in this application **is not accepted** for the reason(s) checked below:
 - a. The Power of Attorney is from an assignee and the Certificate required by 37 CFR 3.73 (b) has not been received.
 - b. The person signing for the assignee has omitted their empowerment to sign on behalf of the assignee.
 - c. The inventor(s) is without authority to appoint attorneys since the assignee has intervened as provided by 37 CFR 3.71.
 - d. The signature of _____, a co-inventor in this application, has been omitted. The Power of Attorney will be entered upon receipt of confirmation signed by said co-inventor.
 - e. The person(s) appointed in the Power of Attorney is not registered to practice before the U. S. Patent & Trademark Office.
 - f. The revocation is not signed by the applicant, the assignee of the entire interest, or one particular principal attorney having the authority to revoke.

WILLIAM N HULSEY III
 GARY CARY WARE & FREIDENRICH LLP
 100 CONGRESS AVENUE
 SUITE 1440
 AUSTIN TX 78701

Kim Blatton
 This is a communication from the
 Patent and Trademark Office

PATENT APPLICATION FEE DETERMINATION RECORD
Effective January 1, 2003

Application or Docket Number

6058103

CLAIMS AS FILED - PART I

	(Column 1)	(Column 2)
TOTAL CLAIMS	39	
FOR	NUMBER FILED	NUMBER EXTRA
TOTAL CHARGEABLE CLAIMS	39 minus 20=	* 19
INDEPENDENT CLAIMS	7 minus 3 =	* 4
MULTIPLE DEPENDENT CLAIM PRESENT <input type="checkbox"/>		

* If the difference in column 1 is less than zero, enter "0" in column 2

CLAIMS AS AMENDED - PART II

	(Column 1)	(Column 2)	(Column 3)
AMENDMENT A	CLAIMS REMAINING AFTER AMENDMENT	HIGHEST NUMBER PREVIOUSLY PAID FOR	PRESENT EXTRA
	Total *	Minus **	=
	Independent *	Minus ***	=
FIRST PRESENTATION OF MULTIPLE DEPENDENT CLAIM <input type="checkbox"/>			

	(Column 1)	(Column 2)	(Column 3)
AMENDMENT B	CLAIMS REMAINING AFTER AMENDMENT	HIGHEST NUMBER PREVIOUSLY PAID FOR	PRESENT EXTRA
	Total *	Minus **	=
	Independent *	Minus ***	=
FIRST PRESENTATION OF MULTIPLE DEPENDENT CLAIM <input type="checkbox"/>			

	(Column 1)	(Column 2)	(Column 3)
AMENDMENT C	CLAIMS REMAINING AFTER AMENDMENT	HIGHEST NUMBER PREVIOUSLY PAID FOR	PRESENT EXTRA
	Total *	Minus **	=
	Independent *	Minus ***	=
FIRST PRESENTATION OF MULTIPLE DEPENDENT CLAIM <input type="checkbox"/>			

* If the entry in column 1 is less than the entry in column 2, write "0" in column 3.
 ** If the "Highest Number Previously Paid For" IN THIS SPACE is less than 20, enter "20."
 *** If the "Highest Number Previously Paid For" IN THIS SPACE is less than 3, enter "3."
 The "Highest Number Previously Paid For" (Total or Independent) is the highest number found in the appropriate box in column 1.

SMALL ENTITY TYPE

OR OTHER THAN SMALL ENTITY

RATE	FEE		RATE	FEE
BASIC FEE	375.00	OR	BASIC FEE	750.00
X\$ 9=	121	OR	X\$18=	
X42=	38	OR	X84=	
+140=		OR	+280=	
TOTAL	214	OR	TOTAL	

SMALL ENTITY OR

OTHER THAN SMALL ENTITY

RATE	ADDITIONAL FEE		RATE	ADDITIONAL FEE
X\$ 9=		OR	X\$18=	
X42=		OR	X84=	
+140=		OR	+280=	
TOTAL ADDIT. FEE		OR	TOTAL ADDIT. FEE	

RATE

ADDITIONAL FEE

RATE

ADDITIONAL FEE

X\$ 9=		OR	X\$18=	
X42=		OR	X84=	
+140=		OR	+280=	
TOTAL ADDIT. FEE		OR	TOTAL ADDIT. FEE	

RATE

ADDITIONAL FEE

RATE

ADDITIONAL FEE

X\$ 9=		OR	X\$18=	
X42=		OR	X84=	
+140=		OR	+280=	
TOTAL ADDIT. FEE		OR	TOTAL ADDIT. FEE	



PATENT APPLICATION SERIAL NO. _____

U.S. DEPARTMENT OF COMMERCE
PATENT AND TRADEMARK OFFICE
FEE RECORD SHEET

09/11/2003 HDEHESS1 00000033 10658163

01 FC:2001	375.00 OP
02 FC:2201	168.00 OP
03 FC:2202	171.00 OP

PTO-1556
(5/87)

*U.S. Government Printing Office: 2002 — 489-267/69033

PATENT APPLICATION SERIAL NO. _____

U.S. DEPARTMENT OF COMMERCE
PATENT AND TRADEMARK OFFICE
FEE RECORD SHEET

Adjustment date: 12/12/2003 UEDUVIJE
11/28/2003 SDIRETA1 00000013 500456 10658163
01 FC:1051 130.00 CR

12/12/2003 UEDUVIJE 00000002 500456 10658163
01 FC:2051 65.00 DA

PTO-1556
(5/87)

*U.S. GPO: 2000-468-987/39595