

Filed on behalf of Innovative Display Technologies LLC  
By: Jeffrey R. Bragalone (jbragalone@bcpc-law.com)  
Bragalone Conroy P.C.  
2200 Ross Ave.  
Suite 4500 – West  
Dallas, TX 75201  
Tel: 214.785.6670  
Fax: 214.786.6680

UNITED STATES PATENT AND TRADEMARK OFFICE  

---

BEFORE THE PATENT TRIAL AND APPEAL BOARD

LG DISPLAY CO., LTD.  
Petitioner

v.

INNOVATIVE DISPLAY TECHNOLOGIES LLC  
Patent Owner

---

Case IPR2014-01362  
U.S. Patent No. 7,384,177  

---

**PATENT OWNER'S PRELIMINARY RESPONSE TO PETITION FOR  
*INTER PARTES* REVIEW OF U.S. PATENT NO. 7,384,177**

Mail Stop PATENT BOARD  
Patent Trial and Appeal Board  
U.S. Patent & Trademark Office  
P.O. Box 1450

## **I. INTRODUCTION**

Patent Owner Innovative Display Technologies LLC (“IDT” or “Patent Owner”) hereby files this preliminary response (“Response”) to the Petition for *Inter Partes* Review of U.S. Patent No. 7,384,177 (the “Petition”) in IPR2014-01362 filed by LG Display Co., LTD (“LGD” or “Petitioner”).

The PTAB should deny the Petition’s request to institute an *inter partes* review (“IPR”) of U.S. Patent No. 7,384,177 (the “’177 patent”) because the grounds in the Petition do not demonstrate a reasonable likelihood of any claims being invalid.

Moreover, the PTAB should deny this Petition or at least revoke its filing date because the Petitioner has failed to comply with 35 U.S.C. 312(a)(2) by failing to name clear real parties-in-interest.

And as further explained at the end of this Response, Patent Owner needs to seek discovery that shows that Petitioner is barred from filing this IPR under 35 U.S.C. 315(b) because its privies were served with a complaint alleging infringement of the ’177 patent more than one year prior to the filing date of the Petition. Patent Owner has outlined its current publicly available evidence on this issue, and if the Board finds that evidence alone sufficient, Patent Owner requests that the Board refuse to institute this IPR due to the Section 315(b) bar.

This Response is timely under 35 U.S.C. § 313 and 37 C.F.R. § 42.107, as it is filed within three months of the September 4, 2014, date of the Notice of Filing Date Accorded to Petition and Time for Filing Patent Owner Preliminary Response. (Paper No. 3.).

Patent Owner does not intend to waive any arguments by not addressing them in this Preliminary Response, and Patent Owner intends to raise additional arguments in the event this IPR is instituted.

To introduce its discussion of why the grounds in the Petition are insufficient, the Preliminary Response first provides an outline of the (1) the Grounds themselves; and (2) the claim construction issues.

**A. *Grounds in Petition***

The Petition includes seven grounds of alleged invalidity – all 103(a) obviousness combinations with the exception of one 102(e) ground – for claims 1-3, 5-7, 9-10, 13-15, 19, 21, and 23-27 of the '177 patent.

*Ground 1: 103(a) - Melby (Claims 1-3, 5-7, 9-10, 13- 15, 19, 21, 23-25, 27)*

*Ground 2: 102(e) - Nakamura (Claims 1, 2, 6, 7, 9, 10, 13-15, 19, 21, 23-24, 26)*

*Ground 3: 103(a) - Baur (Claims 1, 2, 13, 14)*

*Ground 4: 103(a) - Baur and Nakamura (Claims 6, 9, 10, 15, 19, 21, 23)*

*Ground 5: 103(a) - Sasuga and Farchmin (Claims 1, 2, 6, 7, 9, 10, 13, 15, 21)*

*Ground 6: 103(a) Sasuga, Farchmin, and Nakamura (Claims 14 and 19)*

*Ground 7: 103(a) Sasuga, Farchmin, and Pristash Claims 23, 25, and 26)*

For the reasons discussed in Section II below, none of the grounds demonstrate a reasonable likelihood of any claims being invalid.

***B. Claim Construction***

The arguments in this Response stand despite Petitioner’s proposed construction and despite the broadest reasonable construction of the terms. This Preliminary Response does not take a position on claim construction at this point. Patent Owner reserves the right to propose its own construction of any and all claim terms for which an issue arises in the event the PTAB institutes this IPR.

Patent Owner notifies the Board that the district court in *Innovative Display Technologies v. Acer, Inc. et al.*, No. 2:13-cv-522 (E.D. Tex. 2013) (Dkt. No. 101) (“Claim Construction Order”) (Ex. 2003) has ruled on constructions of terms in this patent, including entering an agreed construction of “deformities” that Petitioner adopts in its Petition. (Petition at 8) (Ex. 2003 at 58).

**II. GROUND 1 - 103(a) - Melby (Claims 1-3, 5-7, 9-10, 13- 15, 19, 21, 23-25, 27)**

***A. Claim 1, limitation [1.a] – “hollow cavity or recess completely surrounded by the side walls”***

The Petition alleges that “Melby discloses a housing 30 with continuous side walls 32, 34, 36, and back wall 38, which form a cavity completely surrounded by the side walls.” Petition at 14; *see also id.* at 15 (claim chart identifying the same

elements). But the alleged side walls, 32, 34, and 36 cannot form a cavity completely surrounded by the side walls, because a side wall is missing on one side as shown in the excerpt of Figure 3 below.

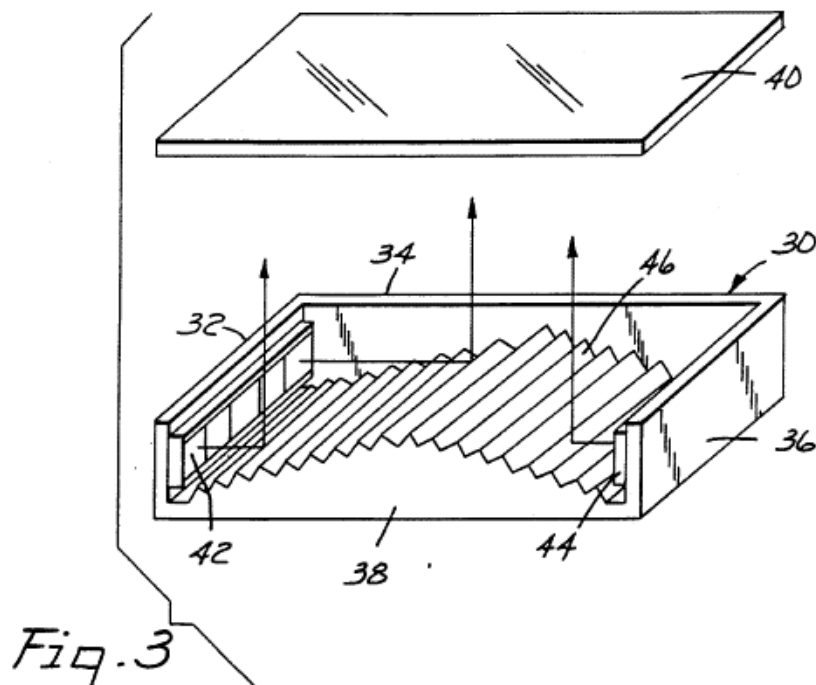

Ex. 1006 at Fig. 3. As seen above, there is no fourth side wall – only side walls 32, 34, and 36 as identified by Petitioner. Moreover, there is no indication that Fig. 3 is a “cross-sectional view” that would otherwise include a “fourth wall” as argued in the Escuti Declaration. Ex. 2004 at 30, ¶ 71. In contrast, the description of Fig. 3 states, “FIG. 3 is a view of a third embodiment of a light fixture according to the invention” (Ex. 1006 at col. 2, ll. 1-2 (emphasis added)) – not a cross-sectional view. Furthermore, the “translucent cover 40” at the top of Fig. 3 is not shown in cross-section, and it would fit in structure below it. Also, the arrowed lines shown in Fig.

# Explore Litigation Insights

Docket Alarm provides insights to develop a more informed litigation strategy and the peace of mind of knowing you're on top of things.

## Real-Time Litigation Alerts



Keep your litigation team up-to-date with **real-time alerts** and advanced team management tools built for the enterprise, all while greatly reducing PACER spend.

Our comprehensive service means we can handle Federal, State, and Administrative courts across the country.

## Advanced Docket Research



With over 230 million records, Docket Alarm's cloud-native docket research platform finds what other services can't. Coverage includes Federal, State, plus PTAB, TTAB, ITC and NLRB decisions, all in one place.

Identify arguments that have been successful in the past with full text, pinpoint searching. Link to case law cited within any court document via Fastcase.

## Analytics At Your Fingertips



Learn what happened the last time a particular judge, opposing counsel or company faced cases similar to yours.

Advanced out-of-the-box PTAB and TTAB analytics are always at your fingertips.

## API

Docket Alarm offers a powerful API (application programming interface) to developers that want to integrate case filings into their apps.

## LAW FIRMS

Build custom dashboards for your attorneys and clients with live data direct from the court.

Automate many repetitive legal tasks like conflict checks, document management, and marketing.

## FINANCIAL INSTITUTIONS

Litigation and bankruptcy checks for companies and debtors.

## E-DISCOVERY AND LEGAL VENDORS

Sync your system to PACER to automate legal marketing.