

The Burstware™ Family of Protocols

Nathaniel Polish, Ph.D.
Director of Technology, Instant Video Technologies
January 1996

1.0 What is "Burstware™"?

Burstware™ is a family of computer network communication protocols embodied in software layers and useful in applications involving multimedia objects. All Burstware™ protocols use substantial amounts of memory on the client system. In most cases, "substantial" means at least a megabyte or more of memory, compared to typical network packet sizes of 1500 bytes or cell sizes of 50 bytes. All Burstware™ protocols involve a close relationship between client and server. Instead of an arrangement in which the client requests what it needs from the server, and hopes that the server has the resources to comply in a timely manner, Burstware™ protocols create a client/server relationship in which the server is aware of each client's needs. The server fills each client's needs in a manner that obtains the most from server and network resources. The environment which best takes advantage of this kind of client/server relationship is one in which the data is video and/or audio, and the network can deliver bandwidths which are greater than necessary for real-time transmission of the media.

1.1 Memory

There are many uses of memory in current network communication systems. The major use of memory on systems such as TCP/IP networks is in the transfer of data packets. On the receiver (client) side, packets must be received completely into memory, decoded, checksummed (checked for errors), and delivered to the addressee. On the transmitter (server) side, packets must be held in memory until receipt of the transmission has been confirmed; in the event of a transmission error, they may have to be re-transmitted. Since packet sizes are relatively small (1500 bytes in most TCP/IP implementations,) the amount of memory on a client protocol stack is fairly small.

On the transmission side, the server's need for memory increases as the network bandwidth increases. This can be seen by examining two important characteristics of a network: bandwidth and latency. Bandwidth is the number of bits delivered per second. Latency is the amount of time that a bit spends in the pipeline between the transmitter and receiver. The speed of light is one component of latency; however, it is common on packet-switched networks (such as the Internet) for a packet to be

received and re-transmitted several times before reaching its addressee. Each transmission adds processing delays that contribute to latency.

On a given network connection, the number of bits in the pipeline is given by the bandwidth times the latency. Latencies tend to be fixed, or at best, shrink slowly with improvements in technology. Local area networks (LANs) have latencies from 1ms to several tens of milliseconds. Wide area networks (WANs) have latencies from 100ms to over 1000ms. Bandwidths however, are growing fast. At 9600 bits per second on a network with 200ms, latency would be less than 2000 bits in the pipeline at any one time. At 155mbps with 100ms, latency would be 15 megabits in the pipeline at any one time. This means that the server must have at least 15 megabits of memory if it needs to, in the event of errors, support re-transmission, and still continuously transmit data. Usually, lack of sufficient memory results in the server slowing its transmission rate.

Use of network file systems for supporting the play of multimedia files adds another set of requirements. Multimedia files (audio and video) are naturally played (consumed) at certain rates. These rates may be constant (constant bit rate, or CBR) or variable (VBR), as in the case of MPEG compressed video. In any event, if the network file system can not guarantee near instantaneous delivery at the consumption rate, then the multimedia file playback will fail. If the latency and bandwidth parameters are constant, then as long as there are no other delays, playback will work. However, as we will see in Section 3, both the latency and the bandwidth available on a network will vary moment-to-moment as a consequence of network traffic and errors. Burstware™ protocols create an environment within the network that enables the network to deal with latency and bandwidth fluctuations in such a way, that multimedia files can be reliably and instantaneously delivered.

1.2 Buckets with Faucets and Open Tops

In general, computer networks are effective at delivering bulk data in correct order, with no errors. The average bandwidth over several seconds can usually be assured, as can the average latency. However, short time scale values for bandwidth and latency usually cannot be guaranteed. In this case, "short time scale" is a relative term that depends on many things; nevertheless, in most current situations, short time scales are on the order of tenths of a second. In a network environment in which the average bandwidth is faster than the real-time demands of multimedia file playback, a burst approach can be used to send multimedia file data.

A metaphor which may be useful in understanding multimedia file transmission is this: Each client has a large bucket into which water (data) is poured. The water is delivered at wide intervals, but when it is delivered, a

large amount is delivered. The server keeps track of how full each of its client's buckets is moment-to-moment, as well as how long it will take to reach each bucket with a new supply of water. The clients are draining the buckets through a faucet at whichever rate suits them. It is the server's job to make sure that all of the buckets are kept as full as possible — to keep track of changes in the time it will take to get to each bucket, and rates at which each client is using its water supply.

The server schedules deliveries to client buckets and clients consume water. The trick is to choose the size of the buckets, and the delivery schedule such that the taps never run dry. Typical client/server relationships can be described as "fill the buckets as fast as possible," or "fill the buckets only as the water is consumed from the tap." A more productive network relationship would be for the server to give preference to buckets that are running close to empty over ones that are more nearly full.

1.3 Client/Server Management

The Burstware™ protocols take the approach that the network system as a whole, not just individual client/server relationships, needs to be managed. The typical assumption in network computing is that the clients are greedy. This is certainly the case, for example, with the FTP protocol. In this protocol, the client program takes as much as it can, as fast as it can, from the server. It is left to both the server and the network operating environment to deliver some level of service that is "equitable" to the rest of the network. This works fine for situations such as FTP, where the semantics of the user's request is: "get me this entire file as soon as you can."

In multimedia file playback environments, the semantics of the client's requests are different from the traditional file transfer semantics. Further, the consequences of applying greedy scheduling to a network supplying multimedia clients does not result in the best service to the most clients. This can best be seen by considering that a client who is about to run out of content material should receive packets sooner than clients who have extensive buffers. Since clients cannot directly cooperate with each other, the server needs to maintain information about their needs and deliver service based on need, rather than on who has the bigger pipe, or who was first at the trough.

When using Burstware™ protocols, the clients regularly inform the server as to their status, the server regularly probes the network to keep track of the prevailing conditions on the network, and the server is constantly updating its schedule of transmission activity to properly serve the clients.

2.0 How it Works

Typical digital video flow is frame by frame at 30 frames per second. This characterizes 601-type video streams. This is known as CBR because each frame holds the same amount of data, and each frame is transmitted at a constant, predictable rate. (See Figure 1 below.)

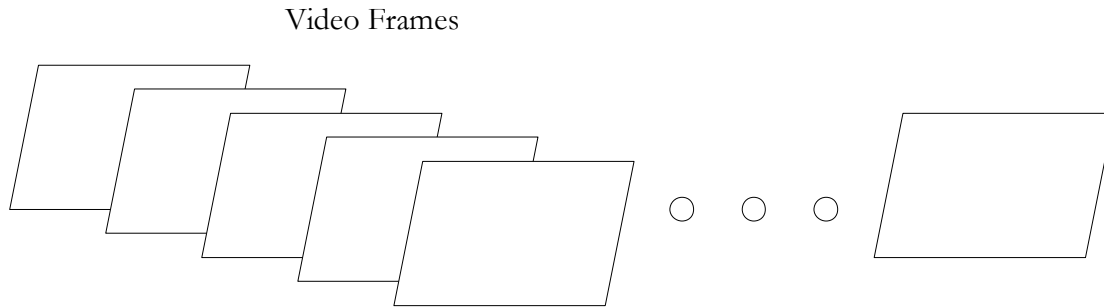

Figure 1. CBR video frames. Each frame contains the same amount of data, and frames are transmitted at a constant rate of frames per second.

This sort of coding takes no advantage of redundancy in the frames; successive frames are rarely very different from each other. Compression techniques such as MPEG cause varying size frames, depending upon the difference from one frame to the next.

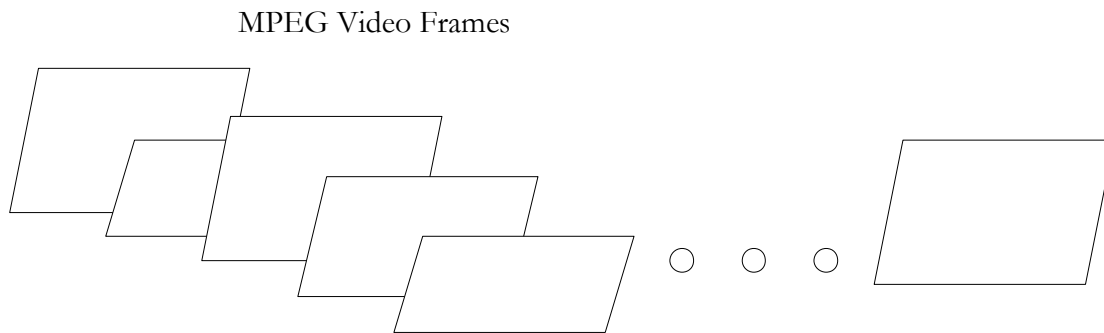

Figure 2. VBR video frames. Each frame contains a different amount of data, usually representing differences from the prior frame. The number of frames transmitted per second can also vary depending upon the complexity of the video stream.

This technique reduces the storage space of the video. However, the number of bits needed to encode the video varies over time. This is known as VBR coding because the number of bits per second varies. (See Figure 2 above.)

Typical state-of-the-art approaches do very little in the way of buffering at the receiver (client) computer. This means that any loss on the network will result in failure to maintain the frame rate. On small local area networks this is rarely a problem. However, as networks are layered, and made larger (e.g., the Internet) it becomes very difficult to provide meaningful service guarantees.

Burstware™ goes beyond typical state-of-the-art approaches to solving these problems, and takes a much more active approach. Our first step is to equip the video clients with several seconds worth of buffer. We then use a network channel with a bit capacity greater than the average video consumption rate. In addition, we use a server with enough capacity to monitor and anticipate the needs of the clients that it is serving.

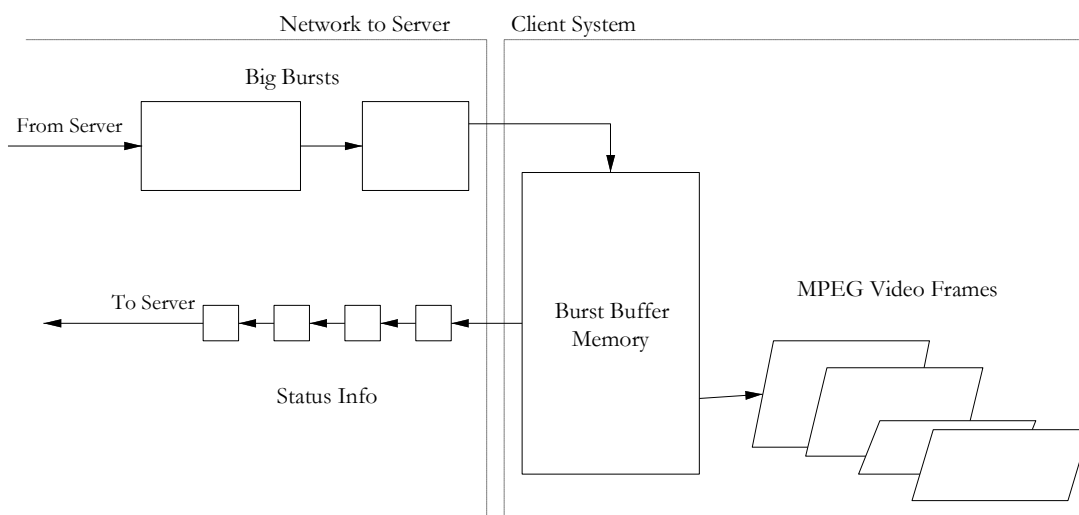

Figure 3. Small status information packets are sent from the client (right) to the server (left) to indicate the state of the Burst Buffer Memory. The server sends bursts of data to the Burst Buffer Memory based on client needs. The client delivers VBR video frames from the Burst Buffer Memory as needed to support video playback.

The Burstware™ client sends the Burstware™ server a series of status packets at regular intervals. (See Figure 3 above.) These packets inform the server as to the fullness of the client's buffer. From this information the server can derive the following:

1. network latency to the client
2. bandwidth to the client
3. how much space the client has for new data
4. the client's average data consumption rate
5. how long the client can run before it has no more video to display

Explore Litigation Insights

Docket Alarm provides insights to develop a more informed litigation strategy and the peace of mind of knowing you're on top of things.

Real-Time Litigation Alerts



Keep your litigation team up-to-date with **real-time alerts** and advanced team management tools built for the enterprise, all while greatly reducing PACER spend.

Our comprehensive service means we can handle Federal, State, and Administrative courts across the country.

Advanced Docket Research



With over 230 million records, Docket Alarm's cloud-native docket research platform finds what other services can't. Coverage includes Federal, State, plus PTAB, TTAB, ITC and NLRB decisions, all in one place.

Identify arguments that have been successful in the past with full text, pinpoint searching. Link to case law cited within any court document via Fastcase.

Analytics At Your Fingertips



Learn what happened the last time a particular judge, opposing counsel or company faced cases similar to yours.

Advanced out-of-the-box PTAB and TTAB analytics are always at your fingertips.

API

Docket Alarm offers a powerful API (application programming interface) to developers that want to integrate case filings into their apps.

LAW FIRMS

Build custom dashboards for your attorneys and clients with live data direct from the court.

Automate many repetitive legal tasks like conflict checks, document management, and marketing.

FINANCIAL INSTITUTIONS

Litigation and bankruptcy checks for companies and debtors.

E-DISCOVERY AND LEGAL VENDORS

Sync your system to PACER to automate legal marketing.