

【図10】

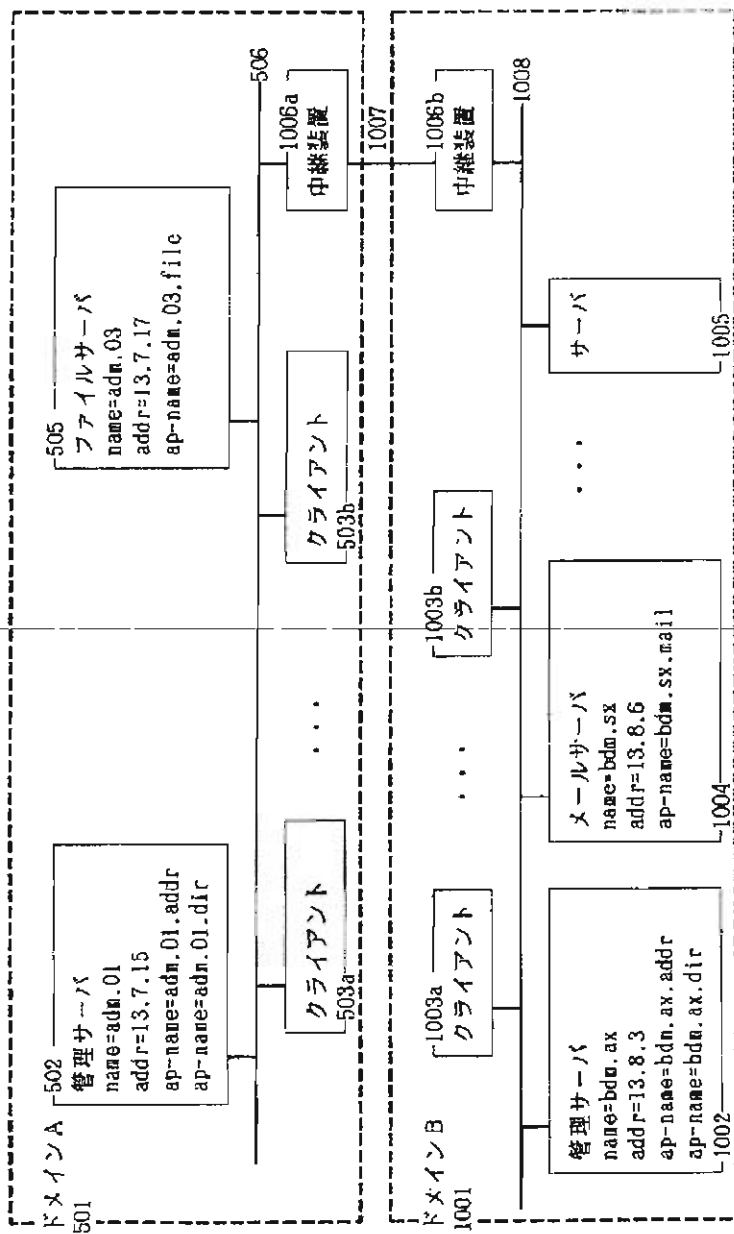

【図10】

【図11】

L I	タイプ	宛先サーバ名称	送信元サーバ名称	変更情報 1108	
				履歴情報	論理アドレス
1101	UPDATE	adm.01.addr	bdm.ax.addr	adm.02	13.8.6
1102		1103	1104	1105	1106
					1107

【図11】

【図12】

【図12】

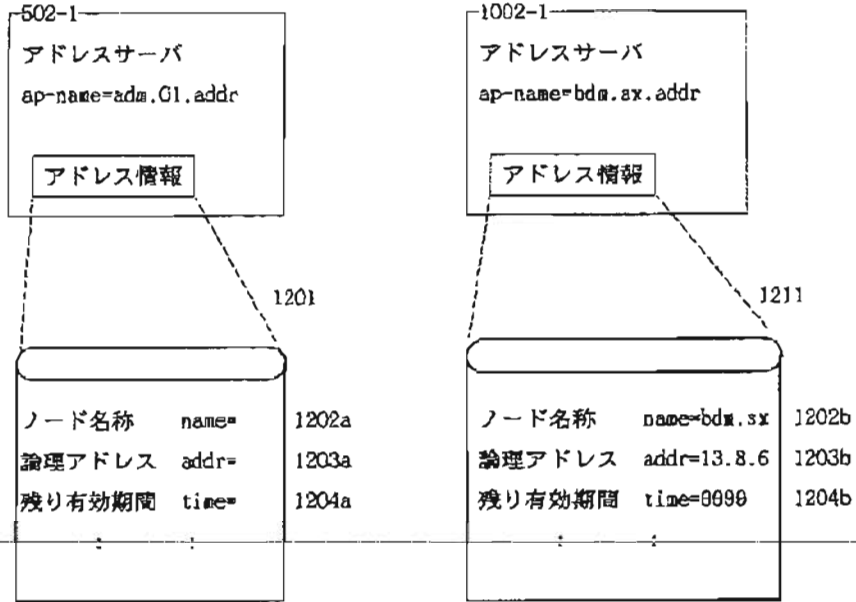

【図14】

【図14】

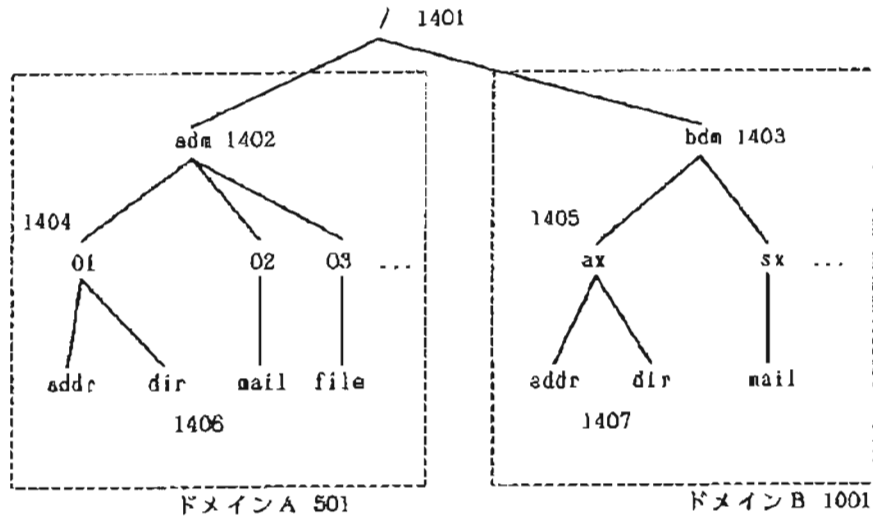

【図13】

【図13】

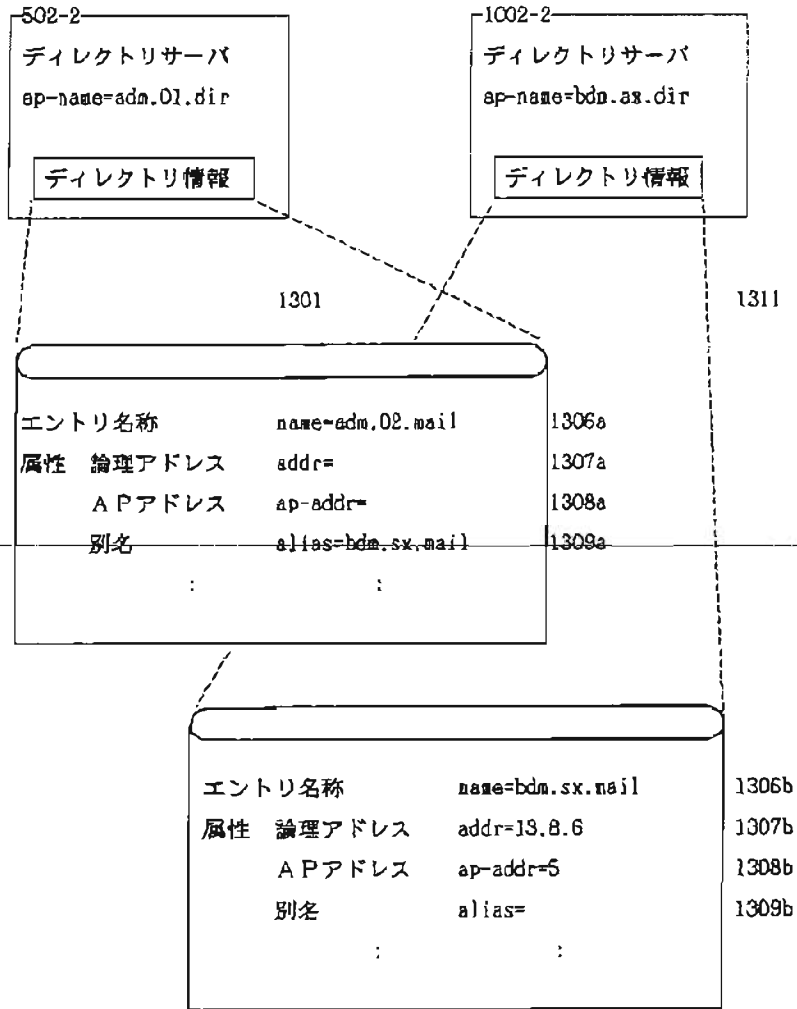

## Electronic Acknowledgement Receipt

<b>EFS ID:</b>	6626107
<b>Application Number:</b>	90010416
<b>International Application Number:</b>	
<b>Confirmation Number:</b>	1061
<b>Title of Invention:</b>	Point-to-Point Internet Protocol
<b>First Named Inventor/Applicant Name:</b>	6108704
<b>Customer Number:</b>	42624
<b>Filer:</b>	Michael R. Casey
<b>Filer Authorized By:</b>	
<b>Attorney Docket Number:</b>	2655-0188
<b>Receipt Date:</b>	14-DEC-2009
<b>Filing Date:</b>	17-FEB-2009
<b>Time Stamp:</b>	11:22:44
<b>Application Type:</b>	Reexam (Third Party)

### Payment information:

Submitted with Payment	no
------------------------	----

### File Listing:

Document Number	Document Description	File Name	File Size(Bytes)/ Message Digest	Multi Part /.zip	Pages (if appl.)
1	NPL Documents	F0057_ISR_US9615504.pdf	396157 <small>e27eccddcd4a00e46c5474618b0320ce804ee73</small>	no	10

### Warnings:

### Information:

2	NPL Documents	F0058_gitman_economic_analysis.pdf	1874599	no	22
			ee5113be03ddc6271d488165e869732cbadd8df5		
<b>Warnings:</b>					
<b>Information:</b>					
3	NPL Documents	F0059_huelamo_end_user_premises.pdf	712273	no	11
			6bafdfc025cd5f1a9069bdc68730628aae79d6ca		
<b>Warnings:</b>					
<b>Information:</b>					
4	NPL Documents	F0060_RFC978.pdf	102320	no	5
			21210c20d1270e7c861516a43079c6e0e80ff401		
<b>Warnings:</b>					
<b>Information:</b>					
5	NPL Documents	F0061_RFC1055.pdf	202556	no	6
			4200eae0048197a08bb15b27455eee7761c31a37		
<b>Warnings:</b>					
<b>Information:</b>					
6	NPL Documents	F0062_james_mills_data_voice.pdf	223076	no	6
			99e23fe5b7fc3074fe2a3c50b94bc2a9f6dc87c		
<b>Warnings:</b>					
<b>Information:</b>					
7	NPL Documents	F0063_james_forgie_speech.pdf	527034	no	8
			da96c67c7acc4ba18886900554b9727f97330cb3		
<b>Warnings:</b>					
<b>Information:</b>					
8	NPL Documents	F0064_james_forgie_voice_conferencing.pdf	500690	no	8
			a64174568406c29dfe7865ab66ec3a5fa4ba6cda		
<b>Warnings:</b>					
<b>Information:</b>					
9	NPL Documents	F0065_Janes_1979_80.pdf	154076	no	3
			9aed6ddfad82f64d8bec6a9194a15c938e7bbf67f		
<b>Warnings:</b>					
<b>Information:</b>					
10	NPL Documents	F0066_Janes_1985.pdf	421297	no	5
			e446be3eb5d4585d956eb7002290badf407b9504		
<b>Warnings:</b>					
<b>Information:</b>					

11	NPL Documents	F0067_Janes_1989.pdf	617418	no	5
			b157df49070abeda57d8c608f714d6688678297		
<b>Warnings:</b>					
<b>Information:</b>					
12	NPL Documents	F0068_Janes_1990_91.pdf	2431238	no	17
			42a97bed6d324612d63934db84cb77220d5c5fec		
<b>Warnings:</b>					
<b>Information:</b>					
13	NPL Documents	F0069_Janes_1992_93.pdf	628193	no	6
			21d4e5f3edaf3a02e9efb3aca1c85067d0cbac48		
<b>Warnings:</b>					
<b>Information:</b>					
14	NPL Documents	F0070_Jim_stevens_Much_more.pdf	262071	no	9
			50b7e1f91c1cb105e4c051099e671685fa777489b		
<b>Warnings:</b>					
<b>Information:</b>					
15	NPL Documents	F0071_John_bellamy_Digital_Telephony.pdf	428289	no	7
			d4118e2dd0b29ce876e901d342c492025712356f		
<b>Warnings:</b>					
<b>Information:</b>					
16	Foreign Reference	F0072_JP-63-131637.pdf	183914	no	6
			c3613862827a91f19076ae80574921c36bce9cee		
<b>Warnings:</b>					
<b>Information:</b>					
17	Foreign Reference	F0073_JP_6-62020.pdf	2765194	no	20
			414e1cc6f9741c12c8db57735f1d3be644d83841		
<b>Warnings:</b>					
<b>Information:</b>					
18	NPL Documents	F0074_JP2008163825_Office_Action_Translation.pdf	487599	no	3
			edbec99254ef68b683d933ac13ebd36e6c0010		
<b>Warnings:</b>					
<b>Information:</b>					
19	NPL Documents	F0075_JP-59-44140.pdf	1272933	no	36
			cb52899aaa212045567f925588a887a5511354ba		
<b>Warnings:</b>					
<b>Information:</b>					

20	NPL Documents	F0076_k_sohraby_ISDN_Primary.pdf	507873 55f133f30db6a34d6cb4023d0e10662a97281ad0	no	9
<b>Warnings:</b>					
<b>Information:</b>					
21	NPL Documents	F0077_ken_sherman_data_communications.pdf	752769 a08045a19608085c077e9ce8d9e66883981b751	no	19
<b>Warnings:</b>					
<b>Information:</b>					
22	NPL Documents	F0078_kevin_jefay_kernel_support.pdf	803713 7cd5cc4ac2748ca37fe3c4c370396da382f6abbcc	no	13
<b>Warnings:</b>					
<b>Information:</b>					
23	NPL Documents	F0079_kyuta_saito_voice_packet_comm.pdf	300668 d249d6607b52412521bb1d75c95d3d19f9f8485	no	6
<b>Warnings:</b>					
<b>Information:</b>					
24	NPL Documents	F0080_lawrence_roberts_evolution_of_packet.pdf	543758 5322ac107dc3164a74af2da29ce1b1b946110e21	no	7
<b>Warnings:</b>					
<b>Information:</b>					
25	NPL Documents	F0081_lin_hwachun_dynamic_load_balancing.pdf	837781 75b8198609e325cf913a2fc40059c640dd383ad7	no	11
<b>Warnings:</b>					
<b>Information:</b>					
26	NPL Documents	F0082_m_e_ulug_Statistical_Multiplexing.pdf	378989 7877617c3d09815a3c55b75fc187620d82b31af5	no	8
<b>Warnings:</b>					
<b>Information:</b>					
27	NPL Documents	F0083_m_gopalakrishnan_integrating_voice_and_data.pdf	748795 ae2a1d3b0f16a57f4409cd4b6e9a3e58384fd0d	no	11
<b>Warnings:</b>					
<b>Information:</b>					
28	NPL Documents	F0084_m_j_ross_alternatives_for_integrating.pdf	504497 77a8d73e1decc48d75853a92cfcf4ee10ee3ab	no	9
<b>Warnings:</b>					
<b>Information:</b>					

29	NPL Documents	F0085_natesa_janakiraman_ove rview_of_recent.pdf	1075971 d414c99a51bd0e8c7e6535564b723d53db 79d492	no	15
<b>Warnings:</b>					
<b>Information:</b>					
30	NPL Documents	F0086_p_borgnis-desbordes. pdf	75088 611bd0e1747e84778c4d1934932595fa064 844e0	no	2
<b>Warnings:</b>					
<b>Information:</b>					
31	NPL Documents	F0087_p_venkat_rangan_softw are_architecture.pdf	817899 0777202a3b6656b761727a4b6648b51bd 9d43b1	no	11
<b>Warnings:</b>					
<b>Information:</b>					
32	NPL Documents	F0088_francis94inet.pdf	2166322 e0eebbd5ade45782f85be64dff45d634ded a645	no	10
<b>Warnings:</b>					
<b>Information:</b>					
33	NPL Documents	F0089_Internet_Navigator_wit h_SOR.pdf	1454997 204999c81ac17d62216ff7dabeebb8f0bb6b 964c	no	13
<b>Warnings:</b>					
<b>Information:</b>					
34	NPL Documents	F0090_Extending_the_IP_Inter net_Through_Address_Reuse. pdf	80075 dea6f7364cb74432a61b08c7a74983fba46a a846	no	18
<b>Warnings:</b>					
<b>Information:</b>					
35	NPL Documents	F0091_philip_h_regan_is_it_th e_PBX.pdf	468795 8187f13bd1f687164c86901826f9c2e364eb ccea	no	6
<b>Warnings:</b>					
<b>Information:</b>					
36	NPL Documents	F0092_polle_t_zellweger_An_ove rview_of_the_etherphone. pdf	972784 efd62ad5ca7c8d116fcd9d7c22bfe879e0d 1187	no	12
<b>Warnings:</b>					
<b>Information:</b>					
37	NPL Documents	F0093_r_braudes_Requirement s_for_Multicast.pdf	904401 75a9dfd492a76d6718ef838d7e4d45314a7f 0c1f	no	18
<b>Warnings:</b>					
<b>Information:</b>					



38	NPL Documents	F0094_r_w_meba_Experiments_in_Wideband.pdf	233947 d37bd24e9482b32dd1ac11c1e925b45a56301c9d	no	7
<b>Warnings:</b>					
<b>Information:</b>					
39	NPL Documents	F0095_r_p_mcNamara_some_considerations.pdf	292918 5a0807f235f0a2a9d5b567add8774601dda7914c2	no	5
<b>Warnings:</b>					
<b>Information:</b>					
40	NPL Documents	F0096_randy_cole_packet_voice_when.pdf	662089 2ef3af18d193b013e58d9dbb1aa29715601a7a07	no	10
<b>Warnings:</b>					
<b>Information:</b>					
41	NPL Documents	F0097_scott_flinn_coordinating_heterogeneous.pdf	1104908 160e963fe632bd1247d97276df6bc2551297bfb8	no	16
<b>Warnings:</b>					
<b>Information:</b>					
42	NPL Documents	F0098_shimmi_hattori_integrated_digital_switching.pdf	656025 5701ee25e31d8c6161e49a8e118ed6fb46c7494	no	7
<b>Warnings:</b>					
<b>Information:</b>					
<b>Total Files Size (in bytes):</b>				30535989	
<p>This Acknowledgement Receipt evidences receipt on the noted date by the USPTO of the indicated documents, characterized by the applicant, and including page counts, where applicable. It serves as evidence of receipt similar to a Post Card, as described in MPEP 503.</p> <p><b><u>New Applications Under 35 U.S.C. 111</u></b>  If a new application is being filed and the application includes the necessary components for a filing date (see 37 CFR 1.53(b)-(d) and MPEP 506), a Filing Receipt (37 CFR 1.54) will be issued in due course and the date shown on this Acknowledgement Receipt will establish the filing date of the application.</p> <p><b><u>National Stage of an International Application under 35 U.S.C. 371</u></b>  If a timely submission to enter the national stage of an international application is compliant with the conditions of 35 U.S.C. 371 and other applicable requirements a Form PCT/DO/EO/903 indicating acceptance of the application as a national stage submission under 35 U.S.C. 371 will be issued in addition to the Filing Receipt, in due course.</p> <p><b><u>New International Application Filed with the USPTO as a Receiving Office</u></b>  If a new international application is being filed and the international application includes the necessary components for an international filing date (see PCT Article 11 and MPEP 1810), a Notification of the International Application Number and of the International Filing Date (Form PCT/RO/105) will be issued in due course, subject to prescriptions concerning national security, and the date shown on this Acknowledgement Receipt will establish the international filing date of the application.</p>					



INTERNATIONAL APPLICATION PUBLISHED UNDER THE PATENT COOPERATION TREATY (PCT)

<p>(51) International Patent Classification 5 : G06F 13/00</p>	<p>A1</p>	<p>(11) International Publication Number: WO 94/22087 (43) International Publication Date: 29 September 1994 (29.09.94)</p>
<p>(21) International Application Number: PCT/US94/00004 (22) International Filing Date: 3 January 1994 (03.01.94) (30) Priority Data: 08/033,914 19 March 1993 (19.03.93) US (71) Applicant: 3COM CORPORATION [US/US]; 5400 Bayfront Plaza, P.O. Box 58145, Santa Clara, CA 95052-8145 (US). (72) Inventors: NILAKANTAN, Chandrasekharan; 3774 Woodbark Court, San Jose, CA 95117 (US). LOL, Ly; 34852 Winchester Plaza, Fremont, CA 94555 (US). ARUNKUMAR, Nagaraj; 3041 Cedar Ridge Court, San Jose, CA 95148 (US). SEAMAN, Michael, John; 350 Elan Village Lane, #206, San Jose, CA 95134 (US). (74) Agent: HAYNES, Mark, A.; Haynes &amp; Davis, Suite 170, 2180 Sand Hill Road, Menlo Park, CA 94025-6935 (US).</p>		<p>(81) Designated States: AU, CA, JP, KR, European patent (AT, BE, CH, DE, DK, ES, FR, GB, GR, IE, IT, LU, MC, NL, PT, SE).  Published With international search report.</p>

(54) Title: SYSTEM FOR REVERSE ADDRESS RESOLUTION FOR REMOTE NETWORK DEVICE

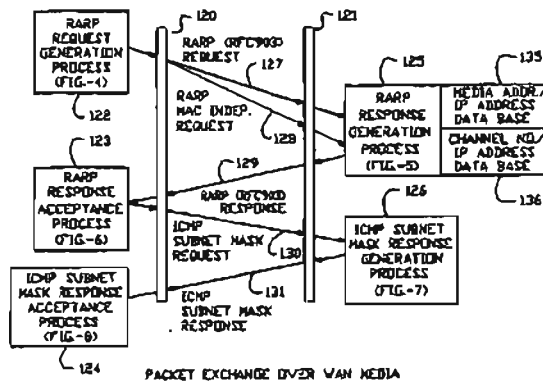

(57) Abstract

A reverse address resolution protocol for use in a communication network which allows resolution logic to provide a higher level protocol information (such as an IP address) to a source of a request (127) for such information (122), independent of the physical network address of such source. The protocol is used in a processor having a plurality of ports, at least one of such ports connected by a point-to-point channel to a remote network device. Reverse address resolution protocol is responsive (129) to a resolution request from the remote network device across the point-to-point channel to supply the higher level protocol information based upon the port through which the resolution request is received (125), rather than the physical network address of the requesting device. Thus, a remote device may be coupled to a network, and connected to a central management site across a point-to-point communication link, in a "plug and play" mode. The person connecting the device to the remote network does not need to determine the physical network address of the device or configure the device with a higher level address protocol.

*FOR THE PURPOSES OF INFORMATION ONLY*

Codes used to identify States party to the PCT on the front pages of pamphlets publishing international applications under the PCT.

AT	Austria	GB	United Kingdom	MR	Mauritania
AU	Australia	GE	Georgia	MW	Malawi
BB	Barbados	GN	Guinea	NR	Niger
BE	Belgium	GR	Greece	NL	Netherlands
BF	Burkina Faso	HU	Hungary	NO	Norway
BG	Bulgaria	IE	Ireland	NZ	New Zealand
BJ	Benin	IT	Italy	PL	Poland
BR	Brazil	JP	Japan	PT	Portugal
BY	Belarus	KE	Kenya	RO	Romania
CA	Canada	KG	Kyrgyzstan	RU	Russian Federation
CF	Central African Republic	KP	Democratic People's Republic of Korea	SD	Sudan
CG	Congo	KR	Republic of Korea	SE	Sweden
CH	Switzerland	KZ	Kazakhstan	SI	Slovenia
CI	Côte d'Ivoire	LI	Liechtenstein	SK	Slovakia
CM	Cameroon	LK	Sri Lanka	SN	Senegal
CN	China	LU	Luxembourg	TD	Chad
CS	Czechoslovakia	LV	Latvia	TG	Togo
CZ	Czech Republic	MC	Monaco	TJ	Tajikistan
DE	Germany	MD	Republic of Moldova	TT	Trinidad and Tobago
DK	Denmark	MG	Madagascar	UA	Ukraine
ES	Spain	ML	Mali	US	United States of America
FI	Finland	MN	Mongolia	UZ	Uzbekistan
FR	France			VN	Viet Nam
GA	Gabon				

**SYSTEM FOR REVERSE ADDRESS RESOLUTION  
FOR REMOTE NETWORK DEVICE**

FIELD OF THE INVENTION

The present invention relates to start up protocols for devices in communication networks; and more particularly to systems which allow a machine without a configured higher level protocol address to obtain such  
5 address without a unique machine identifier.

DESCRIPTION OF RELATED ART

A widely accepted series of international standards describing network architectures is known as the OSI reference model. See, generally,  
10 Tannenbaum, Computer Networks, 2nd Ed., 1988, Prentice-Hall. According to this model, network communications are divided into a plurality of protocols within layers of the model. Local Area Networks (LANs) operate using medium access protocols within the lower layers, layers 1 and 2, of the OSI model, such as the carrier sense multiple access with collision detection  
15 CSMA/CD, IEEE Standard 802.3, also known as ETHERNET, and the token ring access ring method of IEEE Standard 802.5. These two lower layers are typically broken down into the physical layer and the data link layer, with the data link layer being further broken down into a media access control (MAC) layer, and a logical link layer.

20 Systems, such as personal computers, workstations, and mainframe computers, attached to the LANs each have a distinct lower level protocol identifier known as the physical network address or MAC address. LAN frames forwarded to a destination system on the network under these lower level protocols contain the destination system MAC address, or other  
25 physical network address, as a destination. LAN frames forwarded from a source system on the network contain the source system MAC address, or other physical network address, as a source address. Systems

communicate by encapsulating additional protocols (OSI layers 3-7) within the lower layer LAN frames. These higher level protocols are grouped into suites such as the TCP/IP protocol suite and the XNS protocol suite. Many LANs contain groups of end systems that use different higher level protocol  
5 suites. These higher level protocol suites also assign unique higher level protocol identifiers to systems which transmit or receive frames in the network.

For instance, an internet protocol IP address is assigned to each system operating within an internet protocol network. The internet protocol  
10 address includes a network address portion and a host address portion. The network address portion identifies a network within which the system resides, and the host address portion uniquely identifies the system in that network. Processors routing packets in an internet protocol network rely on the network address portion of the IP address in a frame to find the local area  
15 network of the destination machine. Once the local area network of the destination is located, the frame is forwarded to that network where the host address portion is relied upon to assign a MAC address for the destination machine to the packet. Thus, higher level protocol address places the device in a particular network or subnetwork, so that the higher level protocol  
20 can effectively manage the routing of packets among the networks, without maintaining a table of the unique physical access layer identifiers for all of the terminals in the network.

In order to communicate in such a network, the machine must first obtain its higher level protocol address. This address is typically assigned  
25 by a central authority, such as the Internet Activities Board, or by a network manager. Normally, a particular machine learns its IP address by a configure operation, in which a technician uses a local terminal to configure the machine. In a centrally managed network, this could be a cumbersome task, involving travel of skilled personnel away from the central management  
30 location. However, a reverse address resolution protocol RARP has been

developed for networks such as TCP/IP or SNMP protocols. The RARP allows a machine without a configured IP address to obtain an IP address from a remote server. The machine broadcasts a request and waits until an RARP server responds. In the request, the requesting machine must provide  
5 its physical network address (MAC address) to uniquely identify itself, allowing the server to map it into an IP address.

This RARP protocol works fine, so long as the central management site is aware of the physical network address of the devices being added to the network. In order to find out the physical network address, all of the  
10 system being added to the network must be passed through the central management site so that the address can be read from these machines, or a local technician must read the physical network address from the machine and telephone the central site. This process makes connecting a new device to a network difficult. Further, this process of physically reading the physical  
15 network address from the box is prone to human errors. Such addresses are typically very long (MAC addresses are 48 bits long), and can be misread or typed in erroneously.

It is desirable to have so-called "plug and play" network devices. Such devices can be plugged in and turned on by unskilled personnel.  
20 However, the need to find out the physical network address of the box detracts from this ability.

Accordingly, it is desirable to provide a technique for resolving higher level protocol addresses, without reliance on the lower level protocol addresses.  
25

#### SUMMARY OF THE INVENTION

The present invention provides a reverse address resolution protocol for use in a communication network which allows resolution logic to provide a higher level protocol address, or other information, to a source of a request  
30 for such address, independent of the physical network address of such

source. The protocol according to the present invention is used in a processor having a plurality of ports, at least one of such ports connected by a point-to-point channel to a remote network device. The reverse address resolution protocol is responsive to a resolution request from the remote  
5 network device across the point-to-point channel to supply the higher level protocol address based upon the port through which the resolution request is received, rather than the physical network address of the requesting device. Thus, a remote device may be coupled to a network, and connected to a central management site across a point-to-point communication link in  
10 a "plug and play" mode. The person connecting the device to the remote network does not need to determine the physical network address of the device or configure the device with a higher level address protocol. All this can be handled automatically.

Thus, the present invention can be characterized as an apparatus for  
15 resolving higher level protocol addresses in response to resolution requests from a source of resolution requests in a communication network. The apparatus comprises a central processor having a plurality of ports for connection to the communication network, and resolution logic which is coupled to the communication network and in communication with the central  
20 processor. The resolution logic provides a higher level protocol identifier in response to a particular port in the plurality of ports through which the resolution request is received by the central processor, independent of the lower level protocol identifier of the source of the resolution request. The resolution logic may be a routine executed by the central processor, or a  
25 routine executed by a network management processor coupled to the communication network, and in communication with the central processor.

The resolution logic, according to one aspect, includes a resolution  
table that is configurable independent of the lower level protocol identifiers, which assigns higher level protocol identifiers to particular ports of the central  
30 processor through which the resolution requests may be received.

The higher level protocol identifier may comprise an internet protocol IP address, which includes a network address for the source of the resolution request, and a host address for the source of the resolution request. Further, the higher level protocol may be utilized by a network management system, which communicates network-wide, while the lower level protocol comprises a medium access protocol.

The resolution logic, according to the present invention, relies on the source of the resolution request being coupled across a point-to-point communication channel to the particular port of the processor receiving the request. In this way, the port serves as a virtual identifier for the source of the request.

Thus, the present invention can also be characterized as an apparatus for connecting a first network and a second network. This apparatus includes a communication link, a first processor, and a second processor. The first processor has a first interface coupled to the first network and a second interface coupled to the communication link. The second processor has a lower level protocol identifier and is coupled to the second network and to the communication link. Resolution logic is coupled to the first network to provide a higher level protocol identifier to the second processor in response to a resolution request through the second interface of the first processor, independent of the lower level protocol identifier of the second processor. In this manner, the first processor can configure the higher level protocol addresses for devices in the system, independent of the lower level protocol addresses.

According to another aspect of the invention, the first processor includes resources to provide network services to frames of data in the first and second networks through the first and second interfaces, and the second processor includes resources to extend the second interface of the first processor transparently to the second network.



The resolution logic may comprise a routine executed by the first processor, or a routine executed by a network management processor located in the first network.

5 Accordingly, a technique which greatly improves the "plug and play" capability of a network device has been provided. Remote networks may be set up using this system, without requiring error prone and cumbersome techniques to acquire the physical network address of each device being added to the network.

10 Other aspects and advantages of the present invention can be seen upon review of the figures, the detailed description, and the claims which follow.

#### BRIEF DESCRIPTION OF THE FIGURES

15 Fig. 1 is a schematic diagram of a system including the reverse address resolution logic according to the present invention.

Fig. 2 illustrates a prior art packet exchange sequence for reverse address resolution over LAN media.

Fig. 3 illustrates a packet exchange sequence over a WAN medium as extended according to the present invention.

20 Fig. 4 illustrates the resolution request generation process used in the sequence of Fig. 3.

Fig. 5 illustrates the resolution request response generation process used in the sequence of Fig. 3.

25 Fig. 6 illustrates the resolution request response acceptance process used in the sequence of Fig. 3, which results in a request for a subnet mask in IP networks.

Fig. 7 is a diagram of the subnet mask response generation process used in the sequence of Fig. 3.

30 Fig. 8 is a diagram of the subnet mask response acceptance process used in the sequence of Fig. 3.

Fig. 9 is a schematic diagram illustrating one network environment in which the present invention may be used.

#### DETAILED DESCRIPTION OF THE PREFERRED EMBODIMENTS

5 A detailed description of preferred embodiments of the present invention is provided with respect to Figs. 1-9. Fig. 1 illustrates application of the present invention in a preferred embodiment. Figs. 2-8 illustrate the extended protocol for reverse address resolution used in a preferred embodiment of the present invention. Fig. 9 provides an overview of a  
10 network in which the present invention may be applied.

Fig. 1 provides a schematic diagram of an apparatus for connecting a first network 10 to a second network 11 using address resolution logic 25 according to the present invention. The first network 10 includes a first LAN 9 which includes a plurality of end systems and a server, and may be  
15 interconnected to other LANs using intermediate systems (not shown) known in the art. Coupled to the LAN 9 is a boundary router 12. The boundary router 12 is an intermediate system in the network which provides network resources serving higher level protocol suites which, in one unique embodiment, constitute routing resources. As such, the boundary router 12  
20 maintains end system directories 13 for the local LAN 9 and global routing information 14 to serve the routing functions according to the higher level protocol suites. Thus, the end system directories will include DEC end system tables, IPX end system tables, IP end system tables, and others to serve other protocol suites that are operating in the network 10. The  
25 boundary router 12 may also be coupled to other portions of the corporate data network as schematically illustrated at arrow 15.

The boundary router 12 includes a local interface 16 which serves the local LAN 9 providing access to the network resources within the boundary router to end systems on LAN 9. The boundary router could also have  
30 interfaces to other local LANs as well. In addition, the boundary router 12

includes a remote routing interface 17, which provides an interface to the network resources for end systems in the remote network 11. In support of the remote interface 17, the boundary router maintains end system directories 18 serving the higher level protocol suites in the remote network

5 11.

As illustrated schematically by the hatched symbol 19, the remote network 11 appears to the end systems in the local LAN 9 as if it were a LAN connected locally to the boundary router 12. This appearance is maintained across a communication link 20, which may use telephone or

10 other dial up lines, leased lines, satellites, wireless systems, or other communication media configured as a point-to-point channel, to a routing adapter 21, which is coupled to the remote network 11. The remote network 11 includes a remote LAN 22 to which a plurality of end systems and servers may be connected as known in the art. In addition, the LAN 22 may be

15 coupled to other LANs in the remote network 11 through intermediate systems (not shown) as known in the art. The routing adapter 21 provides resources for extending the remote routing interface 17 transparently to the remote network 11 across the communication link 20. From the perspective of the remote network 11, the routing adapter 21 provides the same

20 functionality as a router, while the routing adapter itself operates independent of the higher level protocol suites.

The system thus provides efficient communication between remote networks, and a corporate network, through a boundary router (e.g., net 11, routing adaptor 21, link 20, boundary router 12, net 9).

25 The routing adapter 21 includes hardware performing physical network access protocols for connection to the network 22. Also, such hardware is assigned a physical network address, or MAC address, to uniquely identify the system for the lower level protocol suites. However, in order to participate in the higher level protocol suites managed by the boundary

30 router 12 or elsewhere in the central network 10, an identifier which serves

such higher level protocols is needed for the routing adapter 21. Thus, the boundary router 12 includes resolution logic 25 to provide such identifier in response to the interface 17 across which a request for such identifier is received.

5 Figs. 2-8 illustrate the reverse address resolution protocol executed by the resolution logic 25 in the boundary router of Fig. 1 according to a preferred embodiment, in which the higher level protocol address comprises an internet protocol IP address, such as used by SNMP (Simple Network Management Protocol) standard network management servers.

10 Fig. 2 illustrates the prior art mechanism which is utilized in the preferred system on ports of the routing adaptor coupled to LAN media. The structure of Fig. 2 includes a first interface 100 corresponding to the RARP client port of the routing adapter 21, and a second interface 101 corresponding to an RARP server in the local network 11. The routing  
15 adaptor includes RARP request generation process 102, an RARP response acceptance process 103, and an ICMP subnet mask response acceptance process 104. The resolution logic 25 in the RARP server includes an RARP response generation process 105, and an ICMP subnet mask response generation process 106.

20 Using the industry standard RARP request generation process, as specified in RFC 903 dated June, 1984, the RARP request generation process 102 in the client generates an RARP RFC 903 request 107, which includes the client's MAC address. This request 107 is received at the server interface 101 and the RARP response generation process 105  
25 generates a response 108 by accessing a database or other logic which assigns an IP address based upon the MAC address in the request 107. The RARP response acceptance process 103 in the client receives the IP address from the response 108, stores it as appropriate in the client, and generates an ICMP subnet mask request 109. The server 101 receives the  
30 request 109 and the ICMP subnet mask response generation process 106

supplies a subnet mask response 110 to the client 100. The ICMP subnet mask response acceptance process 104 then configures the client with the IP address and the subnet mask, and assigns the address of the server 101 as the default gateway address.

5           Fig. 3 illustrates this process as extended according to the present invention for reverse address resolution independent of the physical network address of the client. In this aspect, the interface 120 corresponds to the routing adapter 21 operating as an RARP client. The interface 121 corresponds to the interface 17 of the boundary router 12 operating as an RARP server. The RARP server 121 need not be located in the boundary router 12. Rather, it can be located in any in system or intermediate system coupled to the networks served by the boundary router 12.

10           In the extended sequence, as illustrated in Fig. 3, the routing adapter also includes an RARP request generation process 122 (Fig. 4), an RARP response acceptance process 123 (Fig. 6), and an ICMP subnet mask response acceptance process 124 (Fig. 8). The RARP server in the boundary router includes an RARP response generation process 125 (Fig. 5) and an ICMP subnet mask response generation process 126 (Fig. 7).

15           As in the prior art system, the RARP request generation process 122 in the client 120 generates an RARP RFC 903 request 127. Also, the process 122 generates an extended request 128, which indicates to the receiver that the address resolution must be conducted independent of the MAC address.

20           The RARP response generation process 125 receives both the RFC 903 request 127 and the MAC independent request 128. If the response can be served with the RFC 903 request, then the response generation process 125 proceeds that way. However, if the MAC address of the client 120 has not been previously communicated to the response generation process 125, then the MAC independent request 128 must be utilized.

The RARP response generation process 125 is coupled to a media address/IP address database 135 and to a channel number/IP address database 136. These databases are configured by the network manager to assign IP addresses throughout the network. The channel number/IP address database is relied upon when the media address (MAC address) of the client 120 is not available at the time the IP address is configured.

In either event, the RARP response generation process 125 generates an RARP RFC 903 response 129 which includes an IP address. The RARP response acceptance process 123 in the client 120 accepts the IP address and generates an ICMP subnet mask request 130. In the server 121, the ICMP subnet mask response generation process 126 supplies an ICMP subnet mask response 131. The client 120 receives that response and executes the ICMP subnet mask acceptance process 124.

Fig. 4 shows the RARP request generation process corresponding to block 122 of Fig. 3. This routine loops through all of the interfaces or ports on the remote node, also called a leaf node, to determine its IP address. The algorithm starts with an interface up message 400. After an interface up message, the algorithm tests whether the IP address is available in local storage (step 401). If the address is available in local storage, then the routine is done, as indicated at step 402. If the IP address is not available, then an index for the interfaces is set to the first interface (step 403). Next, the algorithm tests whether the interface is up (step 404). If the interface is up, then the RFC 903 RARP request is sent through the interface (step 405). Next, the algorithm tests whether the interface is wide area network WAN interface (step 406). If it is a WAN interface, then the extended RARP request is sent which requires response independent of the MAC address (step 407).

If at step 404, the interface is not up, or if at step 406, the interface is not a WAN interface, or after the extended RARP request is sent in step 407, the algorithm loops to step 408. In step 408, the algorithm tests

whether the index indicates that the last interface has been tested. If not, the index is incremented in step 409 and the algorithm returns to step 404. If the last interface has been served, then the algorithm tests whether any requests have been successfully sent out and are still pending (step 410).  
5 If there are no requests pending because no request was successfully sent, then a send request alarm is set (step 411) and the algorithm is done. If there are requests pending in step 410 because one or more requests were successfully sent, then a request retransmission alarm is set in step 412, and the algorithm is done.

10 The request retransmission alarm results in re-execution of the loop beginning at step 413 which proceeds directly to step 401. The send request alarm set by step 411 results in re-execution of the loop beginning with step 414. After step 414, the algorithm tests whether any requests are still pending in step 415. If there are pending requests, the algorithm is  
15 done, if there are no pending requests, then the loop is entered by proceeding to step 401.

Thus, the RARP request generation process 122, as shown in Fig. 4, sends both the standard RFC 903 RARP request, which requires response based on the MAC address, and an extended RARP request, which requires  
20 response independent of the MAC address, across WAN interfaces. The WAN interface in the preferred system is the point-to-point communication channel 120 between the boundary router and the routing adapter of Fig. 1.

Thus, the extended RARP interface composes a message using the standard message format according to RFC 903. The message is sent in  
25 the data portion of an ethernet frame. An Ethernet frame carrying an RARP request has the usual preamble, ethernet source and destination addresses, and packet type fields in front of the frame. The frame type contains the value 0x8035 to identify the contents as an RARP message. The data portion of the frame contains the 28-octet RARP message.

The RARP client obtains the physical network address of the interface on which the RARP request will be sent out according to the standard techniques known in the art. The RARP request contains the RARP client's physical network address (MAC address) as the source hardware address field, and 0xFFFFFFFF as the destination hardware address. Both the source and destination higher level protocol addresses are undefined, thus, 0. The RARP request opcode is 3 for the standard RARP RFC 903. The protocol according to the present invention uses opcode 16 for the extended request requiring MAC address independent resolution. Of course, any other available opcode could be used.

When the RARP client sends out its first broadcast request for address resolution, it also sets a retransmission timer at 5 seconds according to one embodiment (step 412). This large delay ensures that the server has ample time to satisfy the request and return an answer. When the timer expires, if the client already has an IP address, it cancels the timer and the RARP client goes idle. Otherwise, for each interface which is up, it broadcasts another request and sets the timer again. It will retransmit indefinitely until it receives a response. At each retransmission, the timer will double until it reaches a maximum value 15 minutes. From then on, it will continue using this value.

The RARP client accepts only one response and discards any duplicate responses. Thus, before accepting any response, the client first ensures that no IP address has already been assigned to it.

Fig. 5 illustrates the RARP response generation process corresponding to block 125 of Fig. 3. This algorithm begins with receiving the RARP request 127 or 128 in step 500. After step 500, the algorithm tests whether it is a standard RFC 903 request (step 501).

If the request is the standard RFC 903 format request at step 501, then the algorithm searches the media address/IP address database 135 in step 502.



If the request was not in the standard RFC 903 format, then the algorithm tests whether it is in the extended format (e.g. opcode 16) in step 503. If it is in the extended format, then the channel number/IP address database is searched in step 504. If the request is not in either format, then  
5 the algorithm is done as indicated at step 505.

After searching the database in step 502 or in step 505, the algorithm tests whether a matching entry was found in step 506. If no matching entry was found, then the algorithm is done in block 505. If a matching entry was found, then the algorithm formats and sends an RFC 903 RARP response  
10 packet which provides an IP address to the client (step 507).

Fig. 6 illustrates the RARP response acceptance process 123 of Fig. 3. This algorithm begins with receiving the RARP response in step 600 which was generated in step 507 of Fig. 5. First, the algorithm determines whether the response is expected in step 601. If it is not expected, then the  
15 RARP response is discarded in step 602, and the algorithm is done in step 603. If the response is expected, then the algorithm tests whether an IP address is already available in local storage (step 604). If the address is already available, then the process loops to step 602. If the IP address is not available in step 604, then the IP address from the RARP response is  
20 saved in local storage (step 605). After step 605, all pending alarms in the client are cancelled (step 606), and an ICMP subnet mask request is sent across the interface (block 607). After sending the subnet mask request in step 607, an ICMP subnet mask request retransmission alarm is set in step 608, and the algorithm is done.

25 Thus, once the client or leaf node has obtained the IP address, it initiates an ICMP address mask request to the responder, and sets a retransmission timer of 5 seconds (step 608). The request specifies the RARP server which provided the IP address as the destination. If the leaf node does not obtain a successful response, and its retransmission timer  
30 expires, it will broadcast another ICMP subnet mask request on all available

interfaces and reset the timer to 5 seconds. The maximum number of retransmissions is 10 in one embodiment. If the tenth retransmission fails, it assigns the natural subnet mask to the IP address class. This ensures that the software does not flood the network indefinitely with unnecessary traffic.

5 Fig. 7 illustrates the ICMP subnet mask response generation process corresponding to block 126 of Fig. 3. This process begins with receiving the ICMP subnet mask request in step 700. After receipt of the request, a response is generated and sent to the client in step 701. After sending the response, which includes a subnet mask for the previously sent IP address, the algorithm is done (step 702).

10 Fig. 8 illustrates the ICMP subnet mask response acceptance process corresponding to block 124 of Fig. 3. This algorithm is initiated upon receipt of the ICMP response in step 800. When the response is received, the subnet mask is saved in step 801. Next, any pending alarms are cancelled in step 802. After cancelling the alarms in step 802, the RARP server which supplied the responses to the earlier request is defined as the default gateway in step 803. After defining the default gateway, the algorithm is done as indicated at step 804.

15 If an ICMP retransmission alarm is asserted, this routine receives an indication in step 805. First, the algorithm determines in response to this alarm whether a maximum number of retries has been exceeded in step 806. If it has been exceeded, then the natural mask is utilized for the IP address as indicated at step 807, and the RARP server is set as the default gateway in step 803. If the maximum number of retries has not been exceeded, then an ICMP subnet mask request is generated in step 807, and the ICMP request retransmission alarm is reset in step 808. Finally, the algorithm is done as indicated at step 804.

20 Thus, a preferred embodiment of the present invention extends the RARP standard reverse address resolution protocol to provide for a special

request independent of the MAC address of the client. The RARP server uses the standard ARP table for mapping network physical addresses to IP addresses. It also includes a port-to-IP address table (channel number/IP address) which is used to respond to the extended RARP requests for MAC  
5 independent resolution. This table maps a port number or channel number to an IP address. This method of assigning IP addresses avoids the hassle of having to know the MAC address of the RARP client in advance.

This technique may be extended to other types of protocols, such as the BootP protocol which provides for vendor extensions. In this aspect, the  
10 vendor extensions may also be used for other functions that can be initialized based on the channel number or port upon which request is received by the server. Thus, the BootP request may request an IP address, a configuration manager ID, and configuration information independent of its MAC or physical network address.

15 Fig. 9 illustrates a network configuration in which the present invention may be utilized. According to the configuration of Fig. 9, a central node 900 includes a plurality of ports labelled 1, 2, 3, 4, 5, and 6. Ports 2, 4, and 5 are coupled to respective LANs 901, 902, and 903. LAN 903 includes a system operating as a network management processor 904, which may be  
20 executing such protocols as the SNMP or a Telnet protocol relying on IP addresses to access end systems and intermediate systems in the network.

Port 1 is coupled across a point-to-point communication link 905 to a leaf node 906. Leaf node 906 is coupled to LAN 907.

25 Similarly, node 3 is coupled across point-to-point channel 908 to leaf node 909. Leaf node 909 is coupled to a LAN 910.

Port 6 is coupled across point-to-point channel 911 to leaf node 912. Leaf node 912 is coupled to LAN 913.

30 As illustrated in the figure, LAN 913, link 911, LAN 903, and LAN 902 are all managed as a single IPX network, IPX 1. LAN 907 and LAN 901 are managed as a single IPX network, IPX 2. LAN 910 is managed as an

AppleTalk network. The entire configuration is managed as a single IP network for the purposes of the network management processor 904. Thus, all of the leaf nodes 906, 909, 912 need an IP address for the purposes of the network management processor 904. These IP addresses may be  
5 assigned according to the present invention independent of the physical network address of the leaf node using the MAC address independent IP address resolution logic 914 according to the present invention.

Also, the network management processor 904 may include a server to manage the IP address configuration according to the present invention.  
10 For instance, a BootP protocol vendor extension could be used to tag a request packet requesting an IP address for a leaf node (e.g., node 906) with a channel number for link 905 and node number for central node 900. The central node 900 would then pass the tagged request packet to the remote network management processor 904. The network management processor  
15 904 could then service the request packet with a database based upon the channel number and node number in the tagged request packet.

In the implementation described above based on the modified RARP protocol, the point-to-point channels were implemented using a PPP link, such that the physical port on the central node 900 could be used as a basis  
20 for configuring IP addresses. This node number is passed along with the packet to the processor in the central node according to standard techniques.

Other systems may implement more than one channel on a given physical port on the central node. For instance, a frame relay system may  
25 be used on a given link. In such a system, the DLCI (Data Link Communication Identifier) is carried with every packet on every logical connection between two points in the network. An X.25 type network which uses switched virtual circuits may also be coupled through a particular physical port on the central node 900. In such system, the X.25 address of  
30 the calling device could be used as a basis for specifying the point-to-point

channel. Similarly, an ISDN port could use the unique Identifier for the calling node (Q.931 address) which is used for call set up.

Accordingly, the present invention provides the ability to add new leaf nodes to a network, without requiring the network manager to know the physical network address of the leaf node before it is connected to the network. This greatly simplifies the process of adding new leaf nodes to the network, minimizes the chance of error in communicating the physical network addresses to the network manager, and otherwise contributes to the desired "plug and play" aspect of leaf node hardware.

The foregoing description of preferred embodiments of the present invention has been provided for the purposes of illustration and description. It is not intended to be exhaustive or to limit the invention to the precise forms disclosed. Obviously, many modifications and variations will be apparent to practitioners skilled in this art. The embodiments were chosen and described in order to best explain the principles of the invention and its practical application, thereby enabling others skilled in the art to understand the invention for various embodiments and with various modifications as are suited to the particular use contemplated. It is intended that the scope of the invention be defined by the following claims and their equivalents.

## CLAIMS

What is claimed is:

- 1           1.     An apparatus for resolving higher level protocol identifiers in  
2 response to resolution requests from a source of resolution requests in a  
3 communication network, the source having a lower level protocol identifier,  
4 comprising:  
5           a processor having a plurality of channels for connection to the  
6 communication network; and  
7           resolution logic, coupled with the communication network and in  
8 communication with the processor, to provide a higher level protocol  
9 information in response to a particular channel in the plurality of channels  
10 through which a resolution request is received by the processor independent  
11 of the lower level protocol identifier of the source of the resolution request.
- 1           2.     The apparatus of claim 1, wherein the resolution logic  
2 comprises a routine executed by the processor.
- 1           3.     The apparatus of claim 1, wherein the communication network  
2 includes a network management processor in communication with the  
3 processor, and the resolution logic comprises a routine executed by the  
4 network management processor.
- 1           4.     The apparatus of claim 1, wherein the resolution logic includes  
2 a resolution table configurable independent of lower level protocol identifiers,  
3 for assigning the higher level protocol information to particular channels of  
4 the processor through which resolution requests may be received.

1           5.     The apparatus of claim 1, wherein the higher level protocol  
2 information comprises a network address for the source of the resolution  
3 request.

1           6.     The apparatus of claim 5, wherein the lower level protocol  
2 information comprises a physical network address for the source of the  
3 resolution request.

1           7.     The apparatus of claim 6, wherein the higher level protocol  
2 information comprises an internet protocol IP address.

1           8.     The apparatus of claim 1, wherein the higher level protocol  
2 information comprises a network address for the source of the resolution  
3 request, and a host address for the source of the resolution request.

1           9.     The apparatus of claim 1, wherein the higher level protocol  
2 comprises a network management protocol, and the lower level protocol  
3 comprises a medium access protocol.

1           10.    The apparatus of claim 1, wherein the processor includes  
2 resources to provide network services to frames of data in the  
3 communication network through the plurality of channels.

1           11. An apparatus for connecting a first network and a second  
2 network, comprising:  
3           a communication link;  
4           a first processor, having a first interface coupled to the first network  
5 and a second interface coupled to the communication link;  
6           a second processor having a lower level protocol identifier and  
7 coupled to a second network and to the communication link; and  
8           resolution logic, coupled with the first network, to provide a higher  
9 level protocol information to the second processor in response to a resolution  
10 request through the second interface of the first processor independent of the  
11 lower level protocol identifier of the second processor.

1           12. The apparatus of claim 11, wherein the higher level protocol  
2 information comprises a network address for the second network.

1           13. The apparatus of claim 12, wherein the lower level protocol  
2 identifier comprises a physical network address for the second processor.

1           14. The apparatus of claim 13, wherein the higher level protocol  
2 information comprises an internet protocol IP address.

1           15. The apparatus of claim 11, wherein the higher level protocol  
2 information comprises a network address for the second network, and a host  
3 address for the second processor.

1           16. The apparatus of claim 11, wherein the higher level protocol  
2 comprises a network management protocol, and the lower level protocol  
3 comprises a medium access protocol.



1           17. The apparatus of claim 11, wherein the first processor includes  
2 resources to provide network services to frames of data in the first and  
3 second networks through the first and second interfaces, and the second  
4 processor includes resources to extend the second interface of the first  
5 processor transparently to the second network.

1           18. The apparatus of claim 11, wherein the resolution logic  
2 comprises a routine executed by the first processor.

1           19. The apparatus of claim 11, wherein the first network includes  
2 a network management processor, and the resolution logic comprises a  
3 routine executed by the network management processor.

1           20. The apparatus of claim 11, wherein the resolution logic includes  
2 a resolution table configurable independent of the lower level protocol  
3 identifier of the second processor, for assigning the higher level protocol  
4 information to the second processor in response to the interface through  
5 which the resolution request is received by the first processor.

1           21. The apparatus of claim 11, wherein the communication link  
2 comprises a point-to-point channel, connecting the second interface of the  
3 first processor and the second processor.

1           22. An apparatus for connecting a first local area network and a  
2 second local area network, comprising:  
3           a communication link including a point-to-point channel;  
4           a first processor, having a first interface coupled to the first local area  
5 network and a second interface coupled to the point-to-point channel of the  
6 communication link;

7           a second processor having a physical network identifier and coupled  
8           to the second local area network and to the point-to-point channel of the  
9           communication link; and

10           network management resources, coupled with the first local area  
11           network, operating according to a network management protocol, and  
12           including resolution logic to provide a network management protocol  
13           information to the second processor in response to a resolution request  
14           through the second interface of the first processor, independent of the  
15           physical network identifier of the second processor.

1           23.    The apparatus of claim 22, wherein the resolution logic includes  
2           a resolution table configurable independent of the physical network identifier  
3           of the second processor, for assigning the network management protocol  
4           information to the second processor in response to the interface through  
5           which the resolution request is received by the first processor.

1           24.    The apparatus of claim 22, wherein the network management  
2           protocol information comprises an internet protocol IP address.

1           25.    The apparatus of claim 22, wherein the resolution logic  
2           comprises a routine executed by the first processor.

1           26.    The apparatus of claim 22, wherein the first network includes  
2           a network management processor controlling the network management  
3           resources, and the resolution logic comprises a routine executed by the  
4           network management processor.

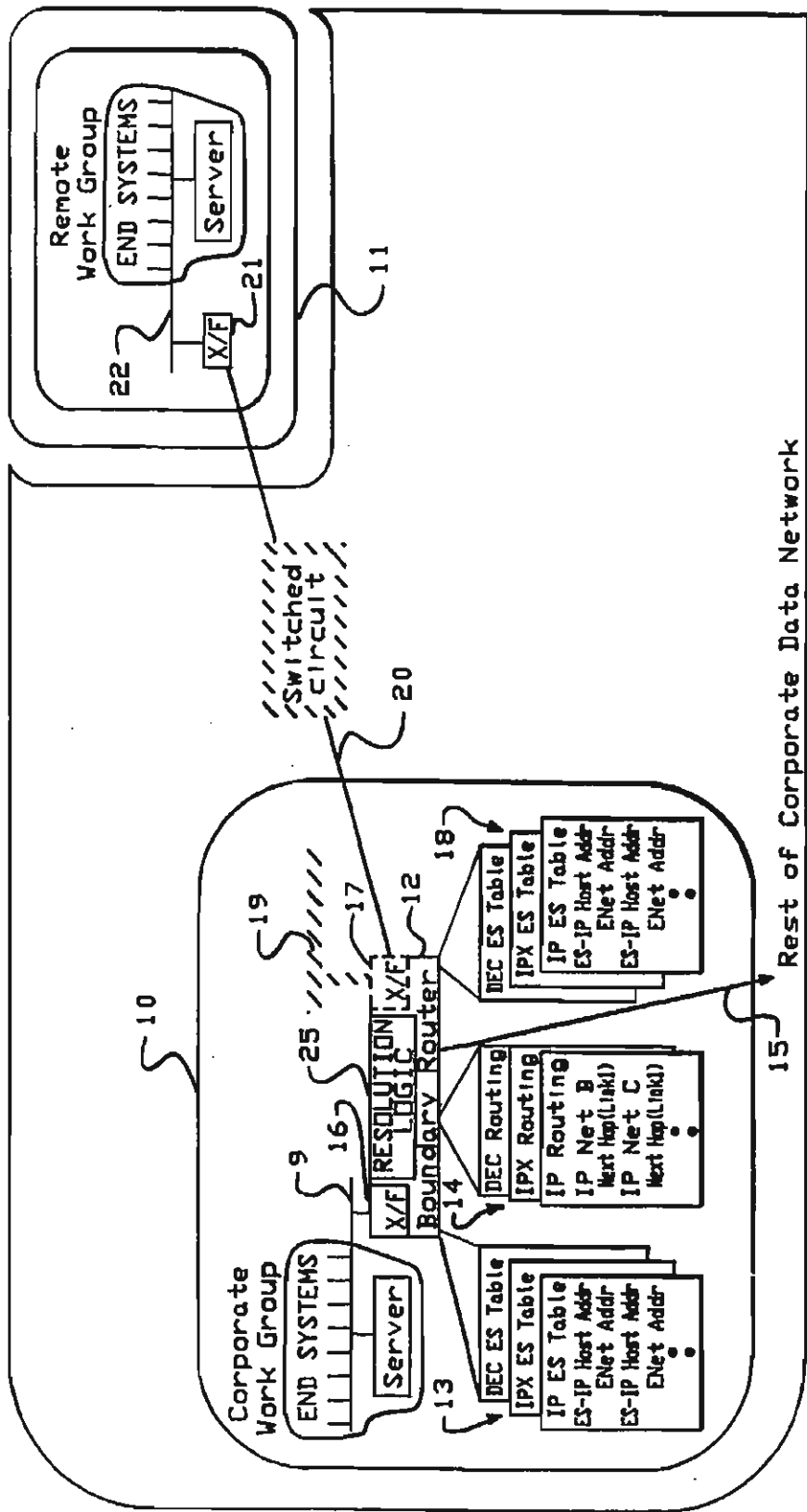

FIG.-1

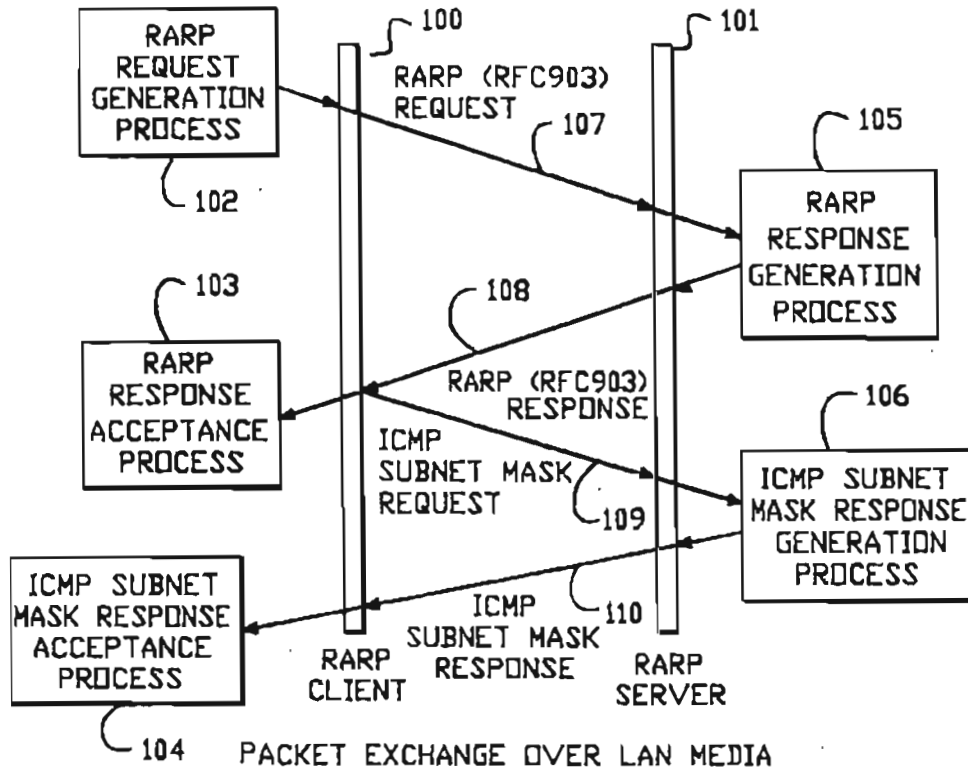

FIG.-2  
(PRIOR ART)

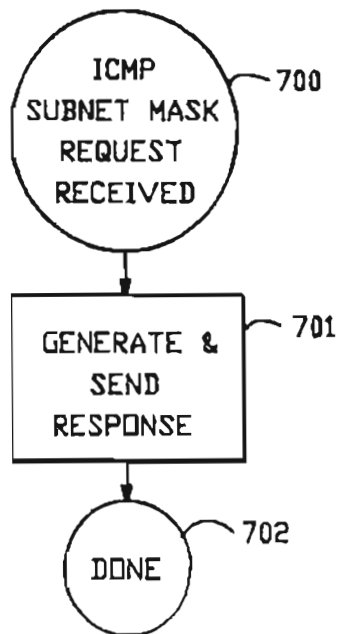

FIG.-7  
2/8.

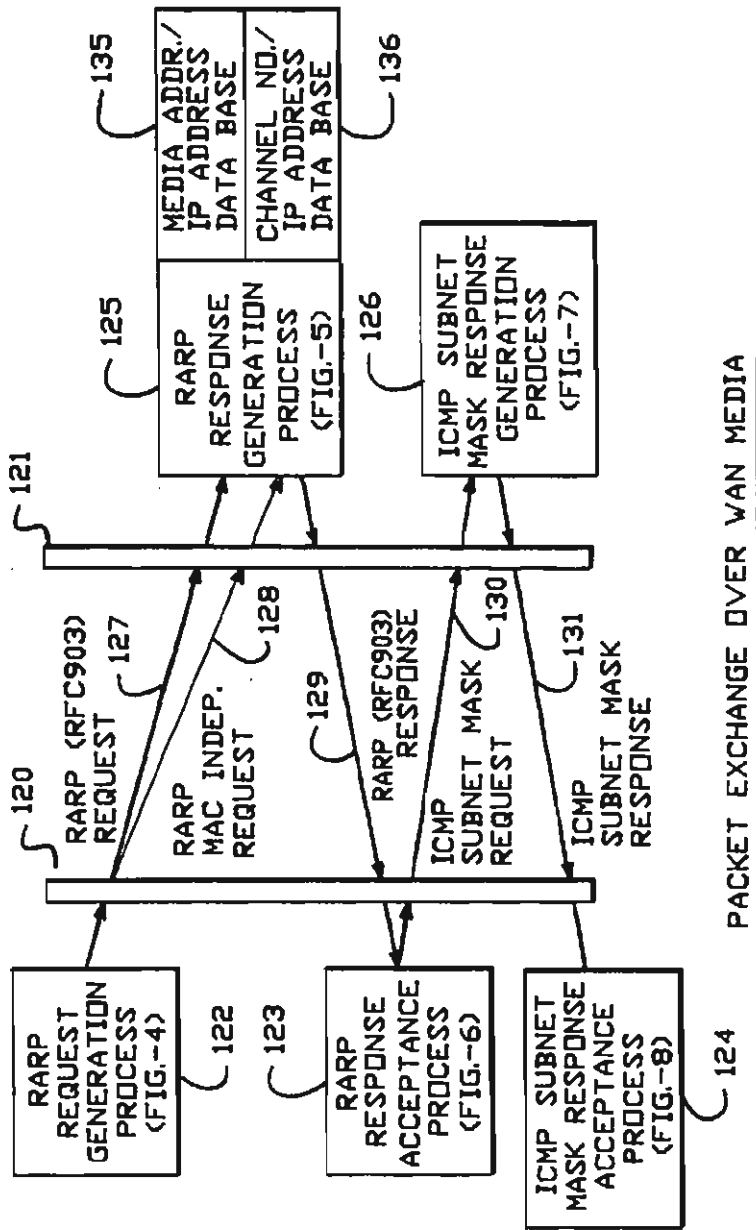

FIG.-3

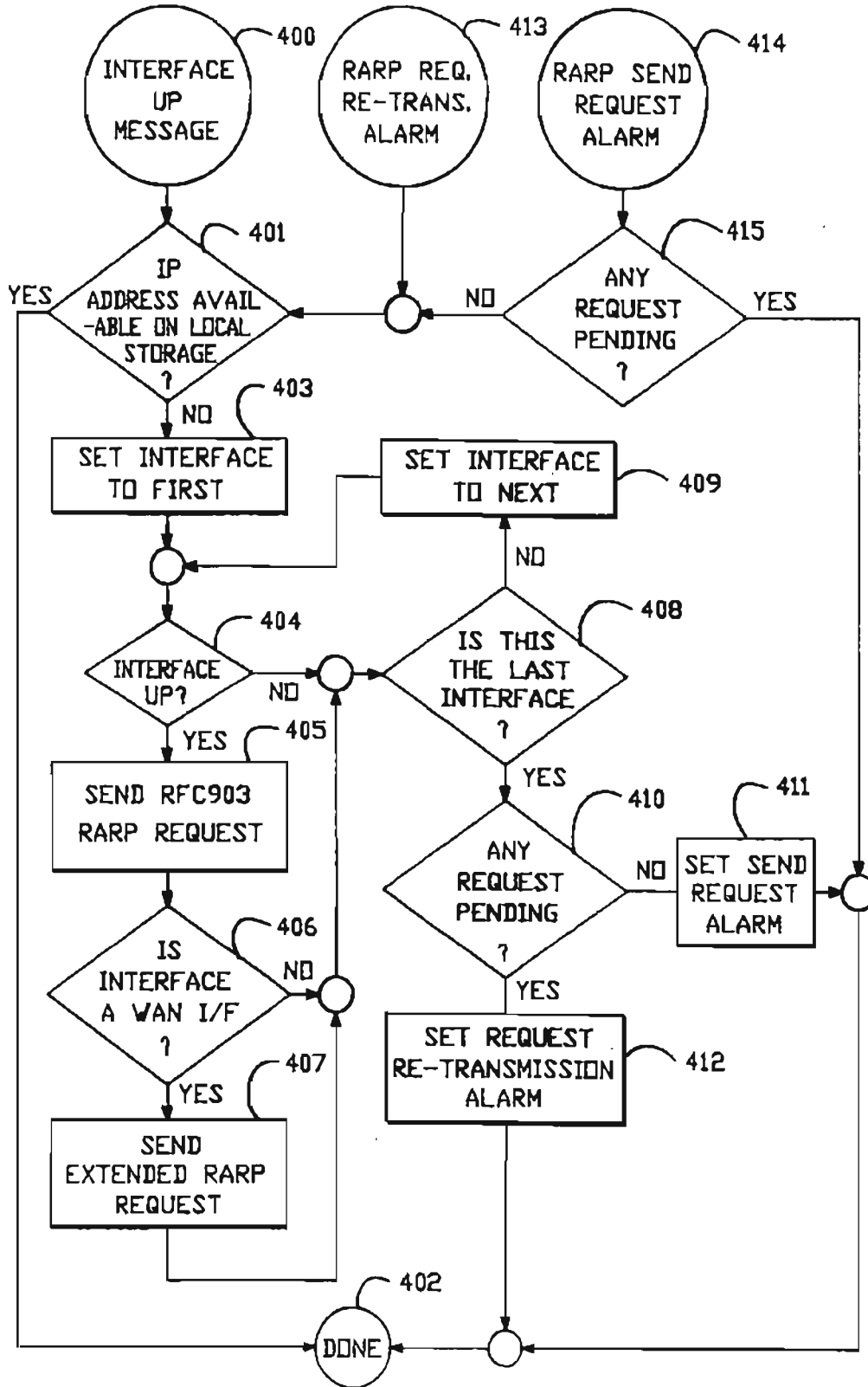

FIG. -4  
4 / 8

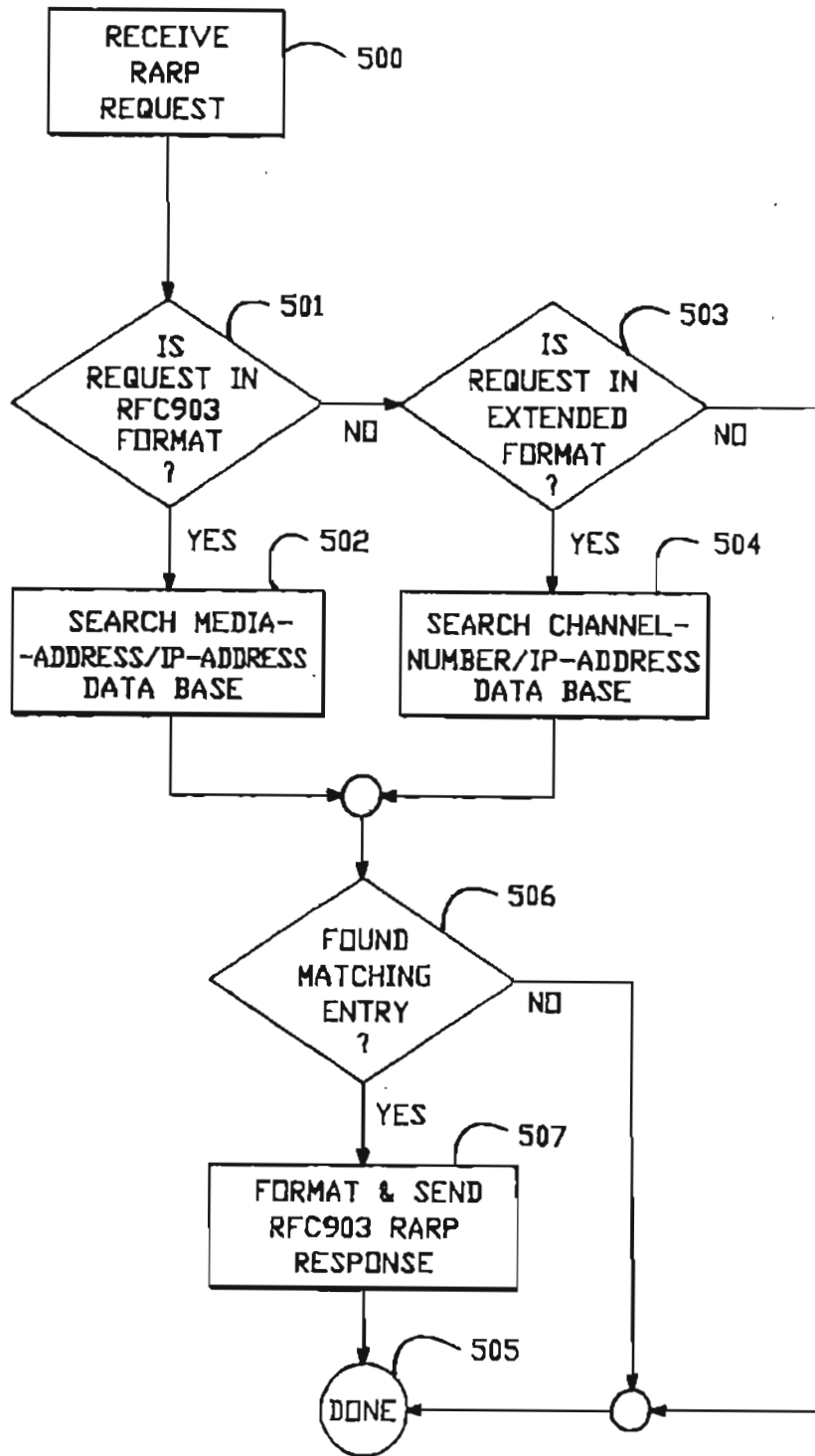

FIG.-5

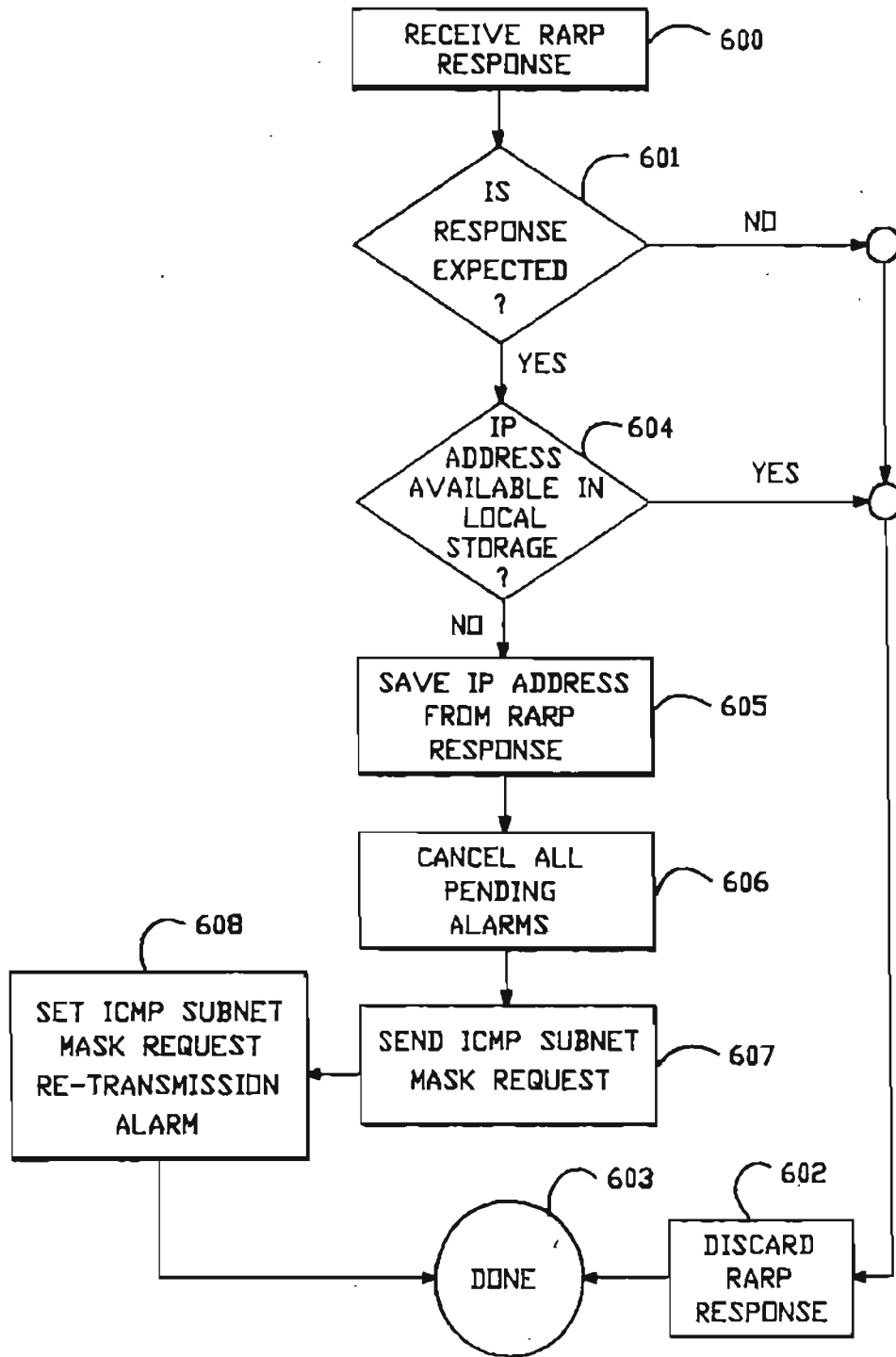

FIG. -6



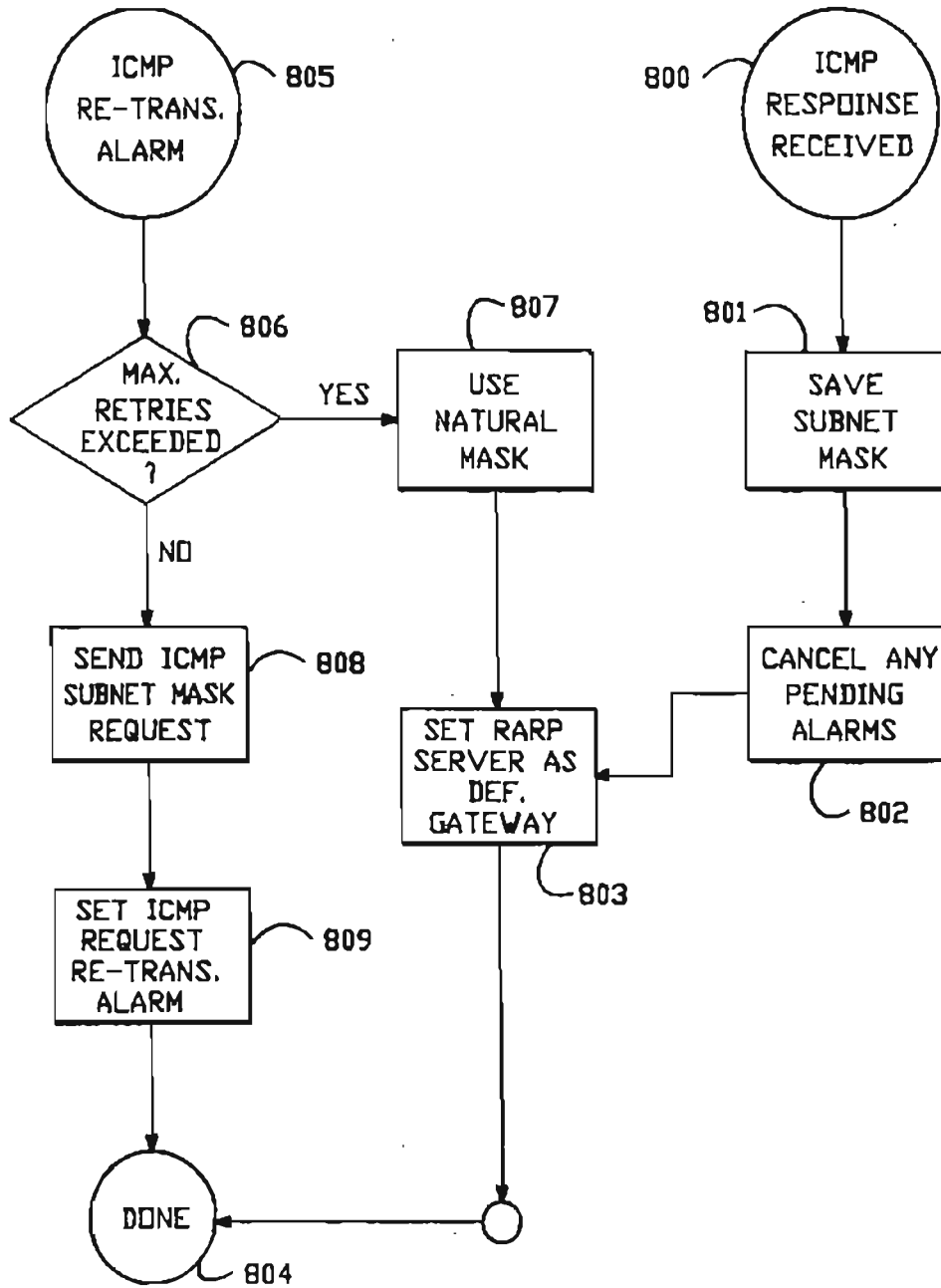

FIG. -8

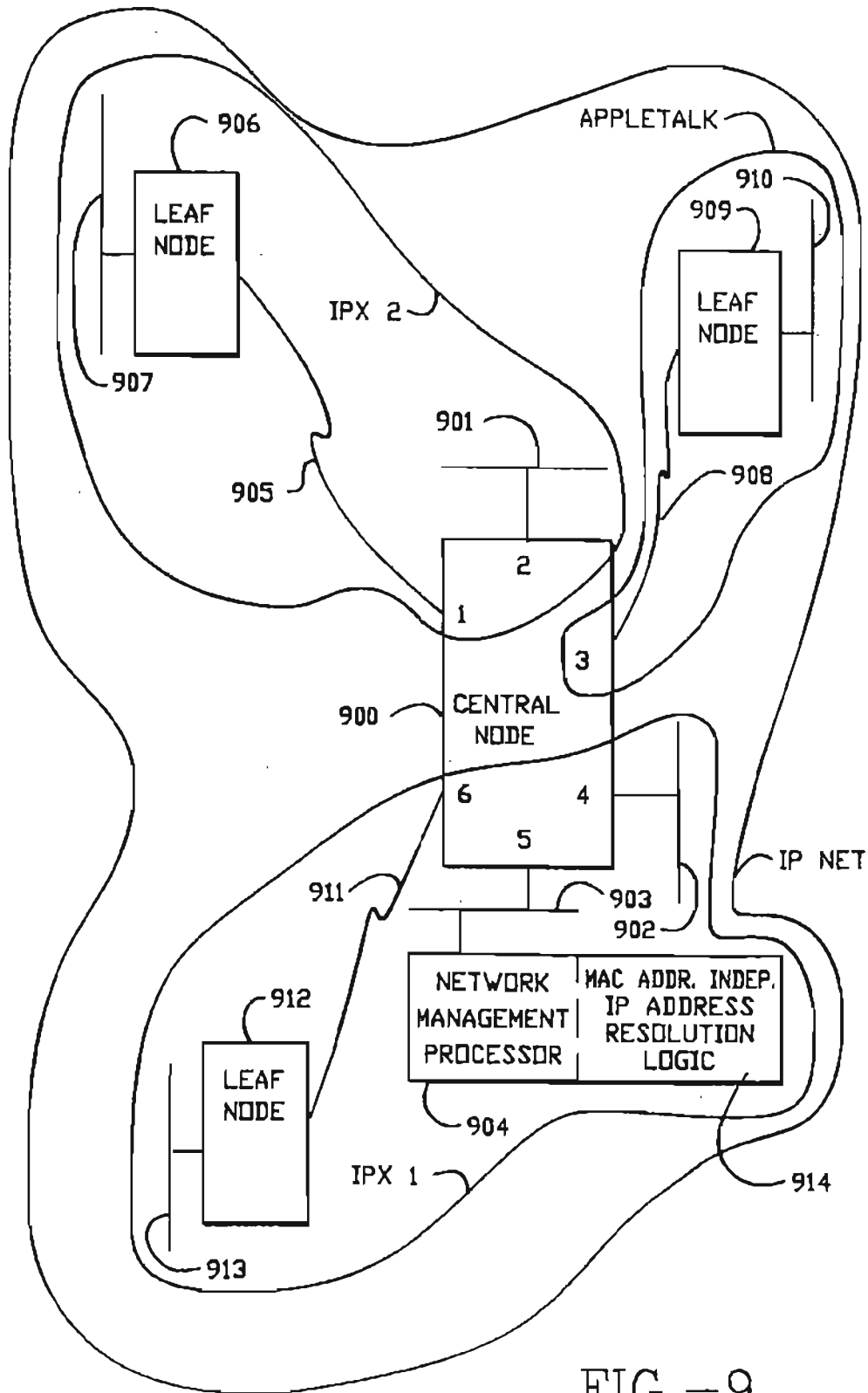

FIG.-9

**INTERNATIONAL SEARCH REPORT**

International application No.  
PCT/US94/00004

<p><b>A. CLASSIFICATION OF SUBJECT MATTER</b>                  IPC(5) :G06F 13/00                  US CL :395/200                  According to International Patent Classification (IPC) or to both national classification and IPC</p>																				
<p><b>B. FIELDS SEARCHED</b></p> <p>Minimum documentation searched (classification system followed by classification symbols)                  U.S. : 395/200</p> <p>Documentation searched other than minimum documentation to the extent that such documents are included in the fields searched</p> <p>Electronic data base consulted during the international search (name of data base and, where practicable, search terms used)                  Please See Extra Sheet.</p>																				
<p><b>C. DOCUMENTS CONSIDERED TO BE RELEVANT</b></p> <table border="1"> <thead> <tr> <th>Category*</th> <th>Citation of document, with indication, where appropriate, of the relevant passages</th> <th>Relevant to claim No.</th> </tr> </thead> <tbody> <tr> <td>A, E</td> <td>US, A, 5,289,579 (PUNJ) 22 February 1994, col. 2 lines 48-56.</td> <td>1-26</td> </tr> <tr> <td>X, E</td> <td>US, A, 5,287,103 (KASPRZYK ET AL) 15 February 1994, col. 2 lines 15-25, col. 4 lines 45-51, 67-68.</td> <td>1-26</td> </tr> <tr> <td>X, P</td> <td>US, A, 5,251,300 (HALLIWELL ET AL) 5 October 1993, col. 1 lines 32-43, 46-50, 55-56, col. 2 lines 21-24.</td> <td>1-5, 11, 12, 18-23, 25, 26</td> </tr> <tr> <td>X</td> <td>US, A, 5,113,495 (UEHARA) 12 May 1992, col. 1 lines 16-19, col. 2 lines 34-37, col. 6 lines 8-10, 22-25, col. 7 lines 16-34, 59-67.</td> <td>1-5, 11-12, 17-23, 25-26</td> </tr> </tbody> </table>			Category*	Citation of document, with indication, where appropriate, of the relevant passages	Relevant to claim No.	A, E	US, A, 5,289,579 (PUNJ) 22 February 1994, col. 2 lines 48-56.	1-26	X, E	US, A, 5,287,103 (KASPRZYK ET AL) 15 February 1994, col. 2 lines 15-25, col. 4 lines 45-51, 67-68.	1-26	X, P	US, A, 5,251,300 (HALLIWELL ET AL) 5 October 1993, col. 1 lines 32-43, 46-50, 55-56, col. 2 lines 21-24.	1-5, 11, 12, 18-23, 25, 26	X	US, A, 5,113,495 (UEHARA) 12 May 1992, col. 1 lines 16-19, col. 2 lines 34-37, col. 6 lines 8-10, 22-25, col. 7 lines 16-34, 59-67.	1-5, 11-12, 17-23, 25-26			
Category*	Citation of document, with indication, where appropriate, of the relevant passages	Relevant to claim No.																		
A, E	US, A, 5,289,579 (PUNJ) 22 February 1994, col. 2 lines 48-56.	1-26																		
X, E	US, A, 5,287,103 (KASPRZYK ET AL) 15 February 1994, col. 2 lines 15-25, col. 4 lines 45-51, 67-68.	1-26																		
X, P	US, A, 5,251,300 (HALLIWELL ET AL) 5 October 1993, col. 1 lines 32-43, 46-50, 55-56, col. 2 lines 21-24.	1-5, 11, 12, 18-23, 25, 26																		
X	US, A, 5,113,495 (UEHARA) 12 May 1992, col. 1 lines 16-19, col. 2 lines 34-37, col. 6 lines 8-10, 22-25, col. 7 lines 16-34, 59-67.	1-5, 11-12, 17-23, 25-26																		
<p><input checked="" type="checkbox"/> Further documents are listed in the continuation of Box C.      <input type="checkbox"/> See patent family annex.</p>																				
<table border="0"> <tr> <td>* Special categories of cited documents:</td> <td>"T"</td> <td>later documents published after the international filing date or priority date and not in conflict with the application but cited to underscore the principle or theory underlying the invention</td> </tr> <tr> <td>*A* document defining the general state of the art which is not considered to be part of particular relevance</td> <td>"X"</td> <td>document of particular relevance; the claimed invention cannot be considered novel or cannot be considered to involve an inventive step when the document is taken alone</td> </tr> <tr> <td>*E* earlier document published on or after the international filing date</td> <td>"Y"</td> <td>document of particular relevance; the claimed invention cannot be considered to involve an inventive step when the document is combined with one or more other such documents, such combination being obvious to a person skilled in the art</td> </tr> <tr> <td>*L* document which may throw doubts on priority claim(s) or which is cited to establish the publication date of another citation or other special reason (as specified)</td> <td>"Z"</td> <td>document member of the same patent family</td> </tr> <tr> <td>*O* document referring to an oral disclosure, use, exhibition or other means</td> <td></td> <td></td> </tr> <tr> <td>*P* document published prior to the international filing date but later than the priority date claimed</td> <td></td> <td></td> </tr> </table>			* Special categories of cited documents:	"T"	later documents published after the international filing date or priority date and not in conflict with the application but cited to underscore the principle or theory underlying the invention	*A* document defining the general state of the art which is not considered to be part of particular relevance	"X"	document of particular relevance; the claimed invention cannot be considered novel or cannot be considered to involve an inventive step when the document is taken alone	*E* earlier document published on or after the international filing date	"Y"	document of particular relevance; the claimed invention cannot be considered to involve an inventive step when the document is combined with one or more other such documents, such combination being obvious to a person skilled in the art	*L* document which may throw doubts on priority claim(s) or which is cited to establish the publication date of another citation or other special reason (as specified)	"Z"	document member of the same patent family	*O* document referring to an oral disclosure, use, exhibition or other means			*P* document published prior to the international filing date but later than the priority date claimed		
* Special categories of cited documents:	"T"	later documents published after the international filing date or priority date and not in conflict with the application but cited to underscore the principle or theory underlying the invention																		
*A* document defining the general state of the art which is not considered to be part of particular relevance	"X"	document of particular relevance; the claimed invention cannot be considered novel or cannot be considered to involve an inventive step when the document is taken alone																		
*E* earlier document published on or after the international filing date	"Y"	document of particular relevance; the claimed invention cannot be considered to involve an inventive step when the document is combined with one or more other such documents, such combination being obvious to a person skilled in the art																		
*L* document which may throw doubts on priority claim(s) or which is cited to establish the publication date of another citation or other special reason (as specified)	"Z"	document member of the same patent family																		
*O* document referring to an oral disclosure, use, exhibition or other means																				
*P* document published prior to the international filing date but later than the priority date claimed																				
<p>Date of the actual completion of the international search 29 March 1994</p>		<p>Date of mailing of the international search report <b>04 MAY 1994</b></p>																		
<p>Name and mailing address of the ISA/US                  Commissioner of Patents and Trademarks                  Box PCT                  Washington, D.C. 20231                  Facsimile No. NOT APPLICABLE</p>		<p>Authorized officer                  DALE SHAW <i>B. Nanda</i>                  Telephone No. (703) 305-9717</p>																		

**INTERNATIONAL SEARCH REPORT**

International application No.  
PCT/US94/00004

C (Continuation). DOCUMENTS CONSIDERED TO BE RELEVANT

Category*	Citation of document, with indication, where appropriate, of the relevant passages	Relevant to claim No.
A	Loi, "RARP Design Specification"-Draft, 21 August 1992 3Com Corp-Network Systems Div., pages 1-11.	1-26
A	Arunkumar, "Boundary Routing Design Specification"-Draft, 14 September 1992 3Com Corp-Network Systems Div., pages 1-13.	1-26
A	Plummer, "An Ethernet Address Resolution Protocol -or- Converting Network Protocol Address to 48.bit Ethernet Address for Transmission on Ethernet Hardware", November 1982 Symbolics, Inc.	1-26
A	Finlayson et al., "A Reverse Address Resolution Protocol", June 1984 Stanford University.	1-26

Form PCT/ISA/210 (continuation of second sheet)(July 1992)\*

# INTERNATIONAL SEARCH REPORT

International application No.  
PCT/US94/00004

## B. FIELDS SEARCHED

Electronic data bases consulted (Name of data base and where practicable terms used):

APS

search terms: reverse address resolution protocol, RARP, processor, channels, communication network, resolution logic, logic, table, internet protocol, IP address



INTERNATIONAL APPLICATION PUBLISHED UNDER THE PATENT COOPERATION TREATY (PCT)

<p>(51) International Patent Classification <sup>6</sup> : <b>H04L</b></p>	<p><b>A2</b></p>	<p>(11) International Publication Number: <b>WO 97/14234</b>  (43) International Publication Date: 17 April 1997 (17.04.97)</p>
<p>(21) International Application Number: PCT/US96/15504 (22) International Filing Date: 25 September 1996 (25.09.96) (30) Priority Data: 08/533,115 25 September 1995 (25.09.95) US (71) Applicant: NETSPEAK CORPORATION [US/US]; Suite 104, 902 Clint Moore Road, Boca Raton, FL 33487 (US). (72) Inventor: HUTTON, Glenn, W.; Apartment 206, 9725 Hammocks Boulevard, Miami, FL 33196 (US). (74) Agent: JOBSE, Bruce, D.; Bookstein &amp; Kudirka, P.C., One Beacon Street, Boston, MA 02108 (US).</p>		<p>(81) Designated States: AU, BR, CA, CN, JP, KR, MX, RU, SG, European patent (AT, BE, CH, DE, DK, ES, FI, FR, GB, GR, IE, IT, LU, MC, NL, PT, SE).  Published <i>Without international search report and to be republished upon receipt of that report.</i></p>

(54) Title: POINT-TO-POINT INTERNET PROTOCOL

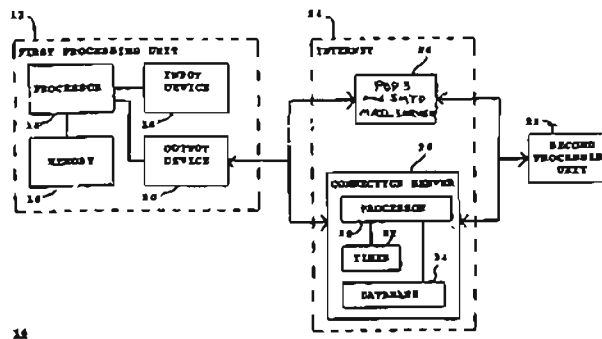

(57) Abstract

A point-to-point Internet protocol exchanges Internet Protocol (IP) addresses between units to establish a point-to-point communication link between the processing units through the Internet. In accordance with the disclosed protocol, a method of locating a user process over a computer network, the user process having a dynamically assigned network protocol address comprises the steps of (a) maintaining in a computer memory a compilation of entries, each entry comprising a network protocol address of a user process connected to the computer network; and (b) in response to identification of one of the entries by a requesting user processor, providing the network protocol address of the identified entry to the requesting user process. In accordance with another embodiment of the invention, a computer system having an audio transducer and a display device and being operatively coupled to other computers and a server over a computer network comprises (a) means for transmitting an E-mail signal containing a network protocol address of a first process to a second process over the computer network; (b) means for receiving a second network protocol address from the second process over the computer network; and (c) means, for responsive to the second network protocol address for establishing a communication link between the first process and the second process over the computer network.

*FOR THE PURPOSES OF INFORMATION ONLY*

Codes used to identify States party to the PCT on the front pages of pamphlets publishing international applications under the PCT.

AM	Armenia	GB	United Kingdom	MW	Malawi
AT	Austria	GE	Georgia	MX	Mexico
AU	Australia	GN	Guinea	NE	Niger
BB	Barbados	GR	Greece	NL	Netherlands
BE	Belgium	HU	Hungary	NO	Norway
BF	Burkina Faso	IE	Ireland	NZ	New Zealand
BG	Bulgaria	IT	Italy	PL	Poland
BJ	Benin	JP	Japan	PT	Portugal
BR	Brazil	KE	Kenya	RO	Romania
BY	Belarus	KG	Kyrgyzstan	RU	Russian Federation
CA	Canada	KP	Democratic People's Republic of Korea	SD	Sudan
CF	Central African Republic	KR	Republic of Korea	SE	Sweden
CG	Congo	KZ	Kazakhstan	SG	Singapore
CH	Switzerland	LI	Liechtenstein	SI	Slovenia
CI	Côte d'Ivoire	LK	Sri Lanka	SK	Slovakia
CM	Cameroon	LR	Liberia	SN	Senegal
CN	China	LT	Lithuania	SZ	Swaziland
CS	Czechoslovakia	LU	Luxembourg	TD	Chad
CZ	Czech Republic	LV	Latvia	TG	Togo
DE	Germany	MC	Monaco	TJ	Tajikistan
DK	Denmark	MD	Republic of Moldova	TT	Trinidad and Tobago
EE	Estonia	MG	Madagascar	UA	Ukraine
ES	Spain	ML	Mali	UG	Uganda
FI	Finland	MN	Mongolia	US	United States of America
FR	France	MR	Mauritania	UZ	Uzbekistan
GA	Gabon			VN	Viet Nam

## POINT-TO-POINT INTERNET PROTOCOL

### FIELD OF THE INVENTION

The present invention relates, in general, to data processing systems, and more specifically, to a method and apparatus for facilitating audio communications over computer networks.

5

### BACKGROUND OF THE INVENTION

The increased popularity of on-line services such as AMERICA ONLINE™, COMPUSERVE®, and other services such as Internet gateways have spurred applications to provide multimedia, including video and voice clips, to online users. An example of an online voice clip application is VOICE E-MAIL FOR WINCIM and VOICE E-MAIL FOR AMERICA ONLINE™, available from Bonzi Software, as described in "Simple Utilities Send Voice E-Mail Online", MULTIMEDIA WORLD, VOL. 2, NO. 9, August 1995, p. 52. Using such Voice E-Mail software, a user may create an audio message to be sent to a predetermined E-mail address specified by the user.

Generally, devices interfacing to the Internet and other online services may communicate with each other upon establishing respective device addresses. One type of device address is the Internet Protocol (IP) address, which acts as a pointer to the device associated with the IP address. A typical device may have a Serial Line Internet Protocol or Point-to-Point Protocol (SLIP/PPP) account with a permanent IP address for receiving E-mail, voicemail, and the like over the Internet. E-mail and voicemail is generally intended to convey text, audio, etc., with any routing information such as an IP address and routing headers generally



being considered an artifact of the communication, or even gibberish to the recipient.

Devices such as a host computer or server of a company may include multiple modems for connection of users to the Internet, with a temporary IP address allocated to each user. For example, the host computer may have a general IP address "XXX.XXX.XXX," and each user may be allocated a successive IP address of XXX.XXX.XXX.10, XXX.XXX.XXX.11, XXX.XXX.XXX.12, etc. Such temporary IP addresses may be reassigned or recycled to the users, for example, as each user is successively connected to an outside party. For example, a host computer of a company may support a maximum of 254 IP addresses which are pooled and shared between devices connected to the host computer.

Permanent IP addresses of users and devices accessing the Internet readily support point-to-point communications of voice and video signals over the Internet. For example, realtime video teleconferencing has been implemented using dedicated IP addresses and mechanisms known as reflectors. Due to the dynamic nature of temporary IP addresses of some devices accessing the Internet, point-to-point communications in realtime of voice and video have been generally difficult to attain.

### SUMMARY OF THE INVENTION

The above deficiencies in the prior art and the previously described needs are fulfilled by the present invention which provides, a directory server utility for providing the dynamically assigned network protocol addresses of client processes currently coupled to the computer network. Accordingly to one embodiment of the present invention, a method of locating users having dynamically assigned network protocol addresses comprises the steps of

maintaining a compilation of entries, each entry comprising a network protocol address of a client process connected to the computer network, and, in response to identification of one of the entries by a requesting client process, providing the network protocol address of the identified entry to the requesting client process.

In accordance with another embodiment of the invention, a computer system having an audio transducer and a display device and being operatively coupled to other computers and a server over a computer network comprises (a) means for transmitting an E-mail signal containing a network protocol address of a first process to a second process over the computer network; (b) means for receiving a second network protocol address from the second process over the computer network; and (c) means, for responsive to the second network protocol address for establishing a communication link between the first process and the second process over the computer network.

#### BRIEF DESCRIPTION OF THE DRAWINGS

The features of the invention will become more readily apparent and may be better understood by referring to the following detailed description of an illustrative embodiment of the present invention, taken in conjunction with the accompanying drawings, in which:

FIG. 1 illustrates, in block diagram format, a system for the disclosed point-to-point Internet protocol;

FIG. 2 illustrates, in block diagram format, the system using a secondary point-to-point Internet protocol;

FIG. 3 illustrates, in block diagram format, the system of FIGS. 1-2 with the point-to-point Internet protocol established;

FIG. 4 is another block diagram of the system of FIGS 1-2 with audio communications being conducted;

FIG. 5 illustrates a display screen for a processing unit;

FIG. 6 illustrates another display screen for a processing unit;

FIG. 7 illustrates a flowchart of the initiation of the point-to-point  
Internet protocols;

5           FIG. 8 illustrates a flowchart of the performance of the primary  
point-to-point Internet protocols; and

          FIG. 9 illustrates a flowchart of the performance of the secondary  
point-to-point Internet protocol.

### DETAILED DESCRIPTION

Referring now in specific detail to the drawings, with like reference numerals identifying similar or identical elements, as shown in FIG. 1, the present disclosure describes a point-to-point network protocol and system  
5 10 for using such a protocol.

In an exemplary embodiment, the system 10 includes a first processing unit 12 for sending at least a voice signal from a first user to a second user. The first processing unit 12 includes a processor 14, a memory 16, an input device 18, and an output device 20. The output  
10 device 20 includes at least one modem capable of, for example, 14.4 kbaud communications and operatively connected via wired and/or wireless communication connections to the Internet or other computer networks such as an Intranet, i.e., a private computer network. One skilled in the art would understand that the input device 18 may be  
15 implemented at least in part by the modem of the output device 20 to allow input signals from the communication connections to be received. The second processing unit 22 may have a processor, memory, and input and output devices, including at least one modem and associated communication connections, as described above for the first processing  
20 unit 12. In an exemplary embodiment, each of the processing units 12, 22 may execute the WEBPHONE™ Internet telephony application available from NetSpeak Corporation, Boca Raton, FL, which is capable of performing the disclosed point-to-point Internet protocol and system 10, as described herein.

25 The first processing unit 12 and the second processing unit 22 are operatively connected to the Internet 24 by communication devices and software known in the art, such as an Internet Service Provider (ISP) or an Internet gateway. The processing units 12, 22 may be operatively interconnected through the Internet 24 to a connection server 26, and

may also be operatively connected to a mail server 28 associated with the Internet 24.

The connection server 26 includes a processor 30, a timer 32 for generating time stamps, and a memory such as a database 34 for storing, for example, E-mail and Internet Protocol (IP) addresses of logged-in units. In an exemplary embodiment, the connection server 26 may be a SPARC 5 server or a SPARC 20 server, available from SUN MICROSYSTEMS, INC., Mountain View, CA, having a central processing unit (CPU) as processor 30, an operating system (OS) such as UNIX, for providing timing operations such as maintaining the timer 32, a hard drive or fixed drive, as well as dynamic random access memory (DRAM) for storing the database 34, and a keyboard and display and/or other input and output devices (not shown in FIG. 1). The database 34 may be an SQL database available from ORACLE or INFORMIX.

In an exemplary embodiment, the mail server 28 may be a Post Office Protocol (POP) Version 3 mail server including a processor, memory, and stored programs operating in a UNIX environment, or, alternatively, another OS, to process E-mail capabilities between processing units and devices over the Internet 24.

The first processing unit 12 may operate the disclosed point-to-point Internet protocol by a computer program described hereinbelow in conjunction with FIG. 6, which may be implemented from compiled and/or interpreted source code in the C++ programming language and which may be downloaded to the first processing unit 12 from an external computer. The operating computer program may be stored in the memory 16, which may include about 8 MB RAM and/or a hard or fixed drive having about 8 MB. Alternatively, the source code may be implemented in the first processing unit 12 as firmware, as an erasable read only memory (EPROM), etc. It is understood that one skilled in the

art would be able to use programming languages other than C++ to implement the disclosed point-to-point network protocol and system 10.

The processor 14 receives input commands and data from a first user associated with the first processing unit 12 through the input device 18, which may be an input port connected by a wired, optical, or a wireless connection for electromagnetic transmissions, or alternatively may be transferable storage media, such as floppy disks, magnetic tapes, compact disks, or other storage media including the input data from the first user.

The input device 18 may include a user interface (not shown) having, for example, at least one button actuated by the user to input commands to select from a plurality of operating modes to operate the first processing unit 12. In alternative embodiments, the input device 18 may include a keyboard, a mouse, a touch screen, and/or a data reading device such as a disk drive for receiving the input data from input data files stored in storage media such as a floppy disk or, for example, an 8 mm storage tape. The input device 18 may alternatively include connections to other computer systems to receive the input commands and data therefrom.

The first processing unit 12 may include a visual interface for use in conjunction with the input device 18 and output device 20 similar to those screens illustrated in FIGS. 5-6, discussed below. It is also understood that alternative devices may be used to receive commands and data from the user, such as keyboards, mouse devices, and graphical user interfaces (GUI) such as WINDOWS™ 3.1 available from MICROSOFT Corporation, Redmond, WA., and other operating systems and GUIs, such as OS/2 and OS/2 WARP, available from IBM CORPORATION, Boca Raton, FL. Processing unit 12 may also include microphones and/or telephone handsets for receiving audio voice data

and commands, speech or voice recognition devices, dual tone multi-frequency (DTMF) based devices, and/or software known in the art to accept voice data and commands and to operate the first processing unit 12.

5           In addition, either of the first processing unit 12 and the second processing unit 22 may be implemented in a personal digital assistant (PDA) providing modem and E-mail capabilities and Internet access, with the PDA providing the input/output screens for mouse interactions or for touchscreen activation as shown, for example, in FIGS. 5-6, as a  
10           combination of the input device 18 and output device 20.

          For clarity of explanation, the illustrative embodiment of the disclosed point-to-point Internet protocol and system 10 is presented as having individual functional blocks, which may include functional blocks labeled as "processor" and "processing unit". The functions represented  
15           by these blocks may be provided through the use of either shared or dedicated hardware, including, but not limited to, hardware capable of executing software. For example, the functions of each of the processors and processing units presented herein may be provided by a shared processor or by a plurality of individual processors. Moreover, the use of  
20           the functional blocks with accompanying labels herein is not to be construed to refer exclusively to hardware capable of executing software. Illustrative embodiments may include digital signal processor (DSP) hardware, such as the AT&T DSP16 or DSP32C, read-only memory (ROM) for storing software performing the operations discussed below,  
25           and random access memory (RAM) for storing DSP results. Very large scale integration (VLSI) hardware embodiments, as well as custom VLSI circuitry in combination with a general purpose DSP circuit, may also be provided. Any and all of these embodiments may be deemed to fail within the meaning of the labels for the functional blocks as used herein.

The processing units 12, 22 are capable of placing calls and connecting to other processing units connected to the Internet 24, for example, via dialup SLIP/PPP lines. In an exemplary embodiment, each processing unit assigns an unsigned long session number, for example, a  
5 32-bit long sequence in a \*.ini file for each call. Each call may be assigned a successive session number in sequence, which may be used by the respective processing unit to associate the call with one of the SLIP/PPP lines, to associate a <ConnectOK> response signal with a <Connect Request> signal, and to allow for multiplexing and  
10 demultiplexing of inbound and outbound conversations on conference lines, as explained hereinafter.

For callee (or called) processing units with fixed IP addresses, the caller (or calling) processing unit may open a "socket", i.e. a file handle or address indicating where data is to be sent, and transmit a <Call>  
15 command to establish communication with the callee utilizing, for example, datagram services such as Internet Standard network layering as well as transport layering, which may include a Transport Control Protocol (TCP) or a User Datagram Protocol (UDP) on top of the IP. Typically, a processing unit having a fixed IP address may maintain at  
20 least one open socket and a called processing unit waits for a <Call> command to assign the open socket to the incoming signal. If all lines are in use, the callee processing unit sends a BUSY signal or message to the callee processing unit. As shown in FIG. 1, the disclosed point-to-point Internet protocol and system 10 operate when a callee processing  
25 unit does not have a fixed or predetermined IP address. In the exemplary embodiment and without loss of generality, the first processing unit 12 is the caller processing unit and the second processing unit 22 is the called processing unit. When either of processing units 12, 22 logs on to the Internet via a dial-up connection, the respective unit is provided a



dynamically allocated IP address by the a connection service provider.

Upon the first user initiating the point-to-point Internet protocol when the first user is logged on to the Internet 24, the first processing unit 12 automatically transmits its associated E-mail address and its  
5 dynamically allocated IP address to the connection server 26. The connection server 26 then stores these addresses in the database 34 and time stamps the stored addresses using timer 32. The first user operating the first processing unit 12 is thus established in the database 34 as an active on-line party available for communication using the  
10 disclosed point-to-point Internet protocol. Similarly, a second user operating the second processing unit 22, upon connection to the Internet 24 through the a connection service provider, is processed by the connection server 26 to be established in the database 34 as an active on-line party.

15 The connection server 26 may use the time stamps to update the status of each processing unit; for example, after 2 hours, so that the on-line status information stored in the database 34 is relatively current. Other predetermined time periods, such as a default value of 24 hours, may be configured by a systems operator.

20 The first user with the first processing unit 12 initiates a call using, for example, a Send command and/or a command to speeddial an N<sup>TH</sup> stored number, which may be labeled [SND] and [SPD] [N], respectively, by the input device 18 and/or the output device 20, such as shown in FIGS. 5-6. In response to either the Send or speeddial commands, the  
25 first processing unit 12 retrieves from memory 16 a stored E-mail address of the callee corresponding to the N<sup>TH</sup> stored number. Alternatively, the first user may directly enter the E-mail address of the callee.

The first processing unit 12 then sends a query, including the E-mail address of the callee, to the connection server 26. The connection

11

server 26 then searches the database 34 to determine whether the callee is logged-in by finding any stored information corresponding to the callee's E-mail address indicating that the callee is active and on-line. If the callee is active and on-line, the connection server 26 then performs  
5 the primary point-to-point Internet protocol; i.e. the IP address of the callee is retrieved from the database 34 and sent to the first processing unit 12. The first processing unit 12 may then directly establish the point-to-point Internet communications with the callee using the IP address of the callee.

10 If the callee is not on-line when the connection server 26 determines the callee's status, the connection server 26 sends an OFF-LINE signal or message to the first processing unit 12. The first processing unit 12 may also display a message such as "Called Party Off-Line" to the first user.

15 When a user logs off or goes off-line from the Internet 24, the connection server 26 updates the status of the user in the database 34; for example, by removing the user's information, or by flagging the user as being off-line. The connection server 26 may be instructed to update the user's information in the database 34 by an off-line message, such as  
20 a data packet, sent automatically from the processing unit of the user prior to being disconnected from the connection server 26. Accordingly, an off-line user is effectively disabled from making and/or receiving point-to-point Internet communications.

25 As shown in FIGS. 2-4, the disclosed secondary point-to-point Internet protocol may be used as an alternative to the primary point-to-point Internet protocol described above, for example, if the connection server 26 is non-responsive, inoperative, and/or unable to perform the primary point-to-point Internet protocol, as a non-responsive condition. Alternatively, the disclosed secondary point-to-point Internet protocol may

be used independent of the primary point-to-point Internet protocol. In the disclosed secondary point-to-point Internet protocol, the first processing unit 12 sends a <ConnectRequest> message via E-mail over the Internet 24 to the mail server 28. The E-mail including the  
5 <ConnectRequest> message may have, for example, the subject

[\*wp#XXXXXXXXX#nnn.nnn.nnn.#emailAddr]

where nnn.nnn.nnn.nnn. is the current (i.e. temporary or permanent) IP address of the first user, and XXXXXXXX is a session number, which may be unique and associated with the request of the first user to initiate  
10 point-to-point communication with the second user.

As described above, the first processing unit 12 may send the <ConnectRequest> message in response to an unsuccessful attempt to perform the primary point-to-point Internet protocol. Alternatively, the first processing unit 12 may send the <ConnectRequest> message in  
15 response to the first user initiating a SEND command or the like.

After the <ConnectRequest> message via E-mail is sent, the first processing unit 12 opens a socket and waits to detect a response from the second processing unit 22. A timeout timer, such as timer 32, may be set by the first processing unit 12, in a manner known in the art, to wait  
20 for a predetermined duration to receive a <ConnectOK> signal. The processor 14 of the first processing unit 12 may cause the output device 20 to output a Ring signal to the user, such as an audible ringing sound, about every 3 seconds. For example, the processor 14 may output a \*.wav file, which may be labeled RING.WAV, which is processed by the  
25 output device 20 to output an audible ringing sound.

The mail server 28 then polls the second processing unit 22, for example, every 3-5 seconds, to deliver the E-mail. Generally, the second processing unit 22 checks the incoming lines, for example, at regular intervals to wait for and to detect incoming E-mail from the mail server 28

through the Internet 24.

Typically, for sending E-mail to users having associated processing units operatively connected to a host computer or server operating an Internet gateway, E-mail for a specific user may be sent  
5 over the Internet 24 and directed to the permanent IP address or the SLIP/PPP account designation of the host computer, which then assigns a temporary IP address to the processing unit of the specified user for properly routing the E-mail. The E-mail signal may include a name or other designation such as a user name which identifies the specific user  
10 regardless of the processing unit assigned to the user; that is, the host computer may track and store the specific device where a specific user is assigned or logged on, independent of the IP address system, and so the host computer may switch the E-mail signal to the device of the specific user. At that time, a temporary IP address may be generated or assigned  
15 to the specific user and device.

Upon detecting and/or receiving the incoming E-mail signal from the first processing unit 12, the second processing unit 22 may assign or may be assigned a temporary IP address. Therefore, the delivery of the E-mail through the Internet 24 provides the second processing unit 22  
20 with a session number as well as IP addresses of both the first processing unit 12 and the second processing unit 22.

Point-to-point communication may then be established by the processing unit 22 processing the E-mail signal to extract the <ConnectRequest> message, including the IP address of the first  
25 processing unit 12 and the session number. The second processing unit 22 may then open a socket and generate a <ConnectOK> response signal, which includes the temporary IP address of the second processing unit 22 as well as the session number of the first processing unit.

The second processing unit 22 sends the <ConnectOK> signal

directly over the Internet 24 to the IP address of the first processing unit 12 without processing by the mail server 28, and a timeout timer of the second processing unit 22 may be set to wait and detect a <Call> signal expected from the first processing unit 12.

5           Realtime point-to-point communication of audio signals over the Internet 24, as well as video and voicemail, may thus be established and supported without requiring permanent IP addresses to be assigned to either of the users or processing units 12, 22. For the duration of the realtime point-to-point link, the relative permanence of the current IP  
10 addresses of the processing units 12, 22 is sufficient, whether the current IP addresses were permanent (i.e. predetermined or preassigned) or temporary (i.e. assigned upon initiation of the point-to-point communication).

In the exemplary embodiment, a first user operating the first  
15 processing unit 12 is not required to be notified by the first processing unit 12 that an E-mail is being generated and sent to establish the point-to-point link with the second user at the second processing unit 22. Similarly, the second user is not required to be notified by the second processing unit 22 that an E-mail has been received and/or a temporary  
20 IP address is associated with the second processing unit 22. The processing units 12, 22 may perform the disclosed point-to-point Internet protocol automatically upon initiation of the point-to-point communication command by the first user without displaying the E-mail interactions to either user. Accordingly, the disclosed point-to-point Internet protocol  
25 may be transparent to the users. Alternatively, either of the first and second users may receive, for example, a brief message of "CONNECTION IN PROGRESS" or the like on a display of the respective output device of the processing units 12, 22.

After the initiation of either the primary or the secondary point-to-

point Internet protocols described above in conjunction with FIGS. 1-2, the point-to-point communication link over the Internet 24 may be established as shown in FIGS. 3-4 in a manner known in the art. For example, referring to FIG. 3, upon receiving the <ConnectorOK> signal from the second processing unit 22, the first processing unit 12 extracts the IP address of the second processing unit 22 and the session number, and the session number sent from the second processing unit 22 is then checked with the session number originally sent from the first processing unit 12 in the <ConnectRequest> message as E-mail. If the session numbers sent and received by the processing unit 12 match, then the first processing unit 12 sends a <Call> signal directly over the Internet 24 to the second processing unit 22; i.e. using the IP address of the second processing unit 22 provided to the first processing unit 12 in the <ConnectOK> signal.

Upon receiving the <Call> signal, the second processing unit 22 may then begin a ring sequence, for example, by indicating or annunciating to the second user that an incoming call is being received. For example, the word "CALL" may be displayed on the output device of the second processing unit 22. The second user may then activate the second processing unit 22 to receive the incoming call.

Referring to FIG. 4, after the second processing unit 22 receives the incoming call, realtime audio and/or video conversations may be conducted in a manner known in the art between the first and second users through the Internet 24, for example, by compressed digital audio signals. Each of the processing units 12, 22 also display to each respective user the words "IN USE" to indicate that the point-to-point communication link is established and audio or video signals are being transmitted.

In addition, either user may terminate the point-to-point

communication link by, for example, activating a termination command, such as by activating an [END] button or icon on a respective processing unit, causing the respective processing unit to send an <End> signal which causes both processing units to terminate the respective sockets, as well as to perform other cleanup commands and functions known in the art.

FIGS. 5-6 illustrate examples of display screens 36 which may be output by a respective output device of each processing unit 12, 22 of FIGS. 1-4 for providing the disclosed point-to-point Internet protocol and system 10. Such display screens may be displayed on a display of a personal computer (PC) or a PDA in a manner known in the art.

As shown in FIG. 5, a first display screen 36 includes a status area 38 for indicating, for example, a called user by name and/or by IP address or telephone number; a current function such as C2; a current time; a current operating status such as "IN USE", and other control icons such as a down arrow icon 40 for scrolling down a list of parties on a current conference line. The operating status may include such annunciators as "IN USE," "IDLE," "BUSY," "NO ANSWER," "OFFLINE," "CALL," "DIALING," "MESSAGES," and "SPEEDDIAL."

Other areas of the display screen 36 may include activation areas or icons for actuating commands or entering data. For example, the display screen 36 may include a set of icons 42 arranged in columns and rows including digits 0-9 and commands such as END, SND, HLD, etc. For example, the END and SND commands may be initiated as described above, and the HLD icon 44 may be actuated to place a current line on hold. Such icons may also be configured to substantially simulate a telephone handset or a cellular telephone interface to facilitate ease of use, as well as to simulate function keys of a keyboard. For example, icons labeled L1-L4 may be mapped to function keys F1-F4 on standard

PC keyboards, and icons C1-C3 may be mapped to perform as combinations of function keys, such as CTRL-F1, CTRL-F2, and CTRL-F3, respectively. In addition, the icons labeled L1-L4 and C1-C3 may include circular regions which may simulate light emitting diodes (LEDs) which indicate that the function or element represented by the respective icon is active or being performed.

Icons L1-L4 may represent each of 4 lines available to the caller, and icons C1-C3 may represent conference calls using at least one line to connect, for example, two or more parties in a conference call. The icons L1-L4 and C1-C3 may indicate the activity of each respective line or conference line. For example, as illustrated in FIG. 5, icons L1-L2 may have lightly shaded or colored circles, such as a green circle, indicating that each of lines 1 and 2 are in use, while icons L3-L4 may have darkly shaded or color circles, such as a red or black circle, indicating that each of lines 3 and 4 are not in use. Similarly, the lightly shaded circle of the icon labeled C2 indicates that the function corresponding to C2 is active, as additionally indicated in the status area 38, while darkly shaded circles of icons labeled C1 and C3 indicate that such corresponding functions are not active.

The icons 42 are used in conjunction with the status area 38. For example, using a mouse for input, a line that is in use, as indicated by the lightly colored circle of the icon, may be activated to indicate a party's name by clicking a right mouse button for 5 seconds until another mouse click is actuated or the [ESC] key or icon is actuated. Thus, the user may switch between multiple calls in progress on respective lines.

Using the icons as well as an input device such as a mouse, a user may enter the name or alias or IP address, if known, of a party to be called by either manually entering the name, by using the speedial feature, or by double clicking on an entry in a directory stored in the



memory, such as the memory 16 of the first processing unit 12, where the directory entries may be scrolled using the status area 38 and the down arrow icon 40.

Once a called party is listed in the status area 38 as being active  
5 on a line, the user may transfer the called party to another line or a conference line by clicking and dragging the status area 38, which is represented by a reduced icon 46. Dragging the reduced icon 46 to any one of line icons L1-L4 transfers the called party in use to the selected line, and dragging the reduced icon 46 to any one of conference line  
10 icons C1-C3 adds the called party to the selected conference call.

Other features may be supported, such as icons 48-52, where icon 48 corresponds to, for example, an ALT-X command to exit the communication facility of a processing unit, and icon 50 corresponds to, for example, an ALT-M command to minimize or maximize the display  
15 screen 36 by the output device of the processing unit. Icon 52 corresponds to an OPEN command, which may, for example, correspond to pressing the O key on a keyboard, to expand or contract the display screen 36 to represent the opening and closing of a cellular telephone. An "opened" configuration is shown in FIG. 5, and a "closed"  
20 configuration is shown in FIG. 6. In the "opened" configuration, additional features such as output volume (VOL) controls, input microphone (MIC) controls, waveform (WAV) sound controls, etc.

The use of display screens such as those shown in FIGS. 5-6 provided flexibility in implementing various features available to the user.  
25 It is to be understood that additional features such as those known in the art may be supported by the processing units 12, 22.

Alternatively, it is to be understood that one skilled in the art may implement the processing units 12, 22 to have the features of the display screens in FIGS. 5-6 in hardware; i.e. a wired telephone or wireless

cellular telephone may include various keys, LEDs, liquid crystal displays (LCDs), and touchscreen actuators corresponding to the icons and features shown in FIGS. 5-6. In addition, a PC may have the keys of a keyboard and mouse mapped to the icons and features shown in FIGS. 5-6.

Referring to FIG. 7, the disclosed point-to-point Internet protocol and system 10 is illustrated. First processing unit 12 initiates the point-to-point Internet protocol in step 56 by sending a query from the first processing unit 12 to the connection server 26. If connection server 26 is operative to perform the point-to-point Internet protocol, in step 58, first processing unit 12 receives an on-line status signal from the connection server 26, such signal may include the IP address of the callee or a "Callee Off-Line" message. Next, first processing unit 12 performs the primary point-to-point Internet protocol in step 60, which may include receiving, at the first processing unit 12, the IP address of the callee if the callee is active and on-line. Alternatively, processing unit 60 may initiate and perform the secondary point-to-point Internet protocol in step 62, if the called party is not active and/or on-line.

Referring to FIG. 8, in conjunction with FIGS. 1 and 3-4, the disclosed point-to-point Internet protocol and system 10 is illustrated. Connection server 26 starts the point-to-point Internet protocol, in step 64, and timestamps and stores E-mail and IP addresses of logged-in users and processing units in the database 34 in step 66. Connection server 26 receives a query from a first processing unit 12 in step 68 to determine whether a second user or second processing unit 22 is logged-in to the Internet 24, with the second user being specified, for example, by an E-mail address. Connection server 26 retrieves the IP address of the specified user from the database 34 in step 70, if the specified user is logged-in to the Internet, and sends the retrieved IP address to the first

cellular telephone may include various keys, LEDs, liquid crystal displays (LCDs), and touchscreen actuators corresponding to the icons and features shown in FIGS. 5-6. In addition, a PC may have the keys of a keyboard and mouse mapped to the icons and features shown in FIGS.

5 5-6.

Referring to FIG. 7, the disclosed point-to-point Internet protocol and system 10 is illustrated. First processing unit 12 initiates the point-to-point Internet protocol in step 56 by sending a query from the first processing unit 12 to the connection server 26. If connection server 26 is operative to perform the point-to-point Internet protocol, in step 58, first processing unit 12 receives an on-line status signal from the connection server 26, such signal may include the IP address of the callee or a "Callee Off-Line" message. Next, first processing unit 12 performs the primary point-to-point Internet protocol in step 60, which may include receiving, at the first processing unit 12, the IP address of the callee if the callee is active and on-line. Alternatively, processing unit 60 may initiate and perform the secondary point-to-point Internet protocol in step 62, if the called party is not active and/or on-line.

Referring to FIG. 8, in conjunction with FIGS. 1 and 3-4, the disclosed point-to-point Internet protocol and system 10 is illustrated. Connection server 26 starts the point-to-point Internet protocol, in step 64, and timestamps and stores E-mail and IP addresses of logged-in users and processing units in the database 34 in step 66. Connection server 26 receives a query from a first processing unit 12 in step 68 to determine whether a second user or second processing unit 22 is logged-in to the Internet 24, with the second user being specified, for example, by an E-mail address. Connection server 26 retrieves the IP address of the specified user from the database 34 in step 70, if the specified user is logged-in to the Internet, and sends the retrieved IP address to the first

processing unit 12 in step 72 to enable first processing unit 12 to establish point-to-point communications with the specified second user.

The disclosed secondary point-to-point Internet protocol operates as shown in FIG. 9. First processing unit 12 generates an E-mail signal, including a session number and a first IP address corresponding to a first processing unit in step 76. First processing unit 12 transmits the E-mail signal as a <ConnectRequest> signal to the Internet 24 in step 78. The E-mail signal is delivered through the Internet 24 using a mail server 28 to the second processing unit 22 in step 80. Second processing unit 22 extracts the session number and the first IP address from the E-mail signal in step 82 and transmits or sends the session number and a second IP address corresponding to the second processing unit 22, back to the first processing unit 12 through the Internet 24, in step 84. First processing unit 12 verifies the session number received from the second processing unit 22 in step 86, and establishes a point-to-point Internet communication link between the first processing unit 12 and second processing unit 22 using the first and second IP addresses in step 88.

While the disclosed point-to-point Internet protocols and system have been particularly shown and described with reference to the preferred embodiments, it is understood by those skilled in the art that various modifications in form and detail may be made therein without departing from the scope and spirit of the invention. Accordingly, modifications such as those suggested above, but not limited thereto, are to be considered within the scope of the invention.

What is claimed is:

- 1 1. A method of locating a user over a computer network comprising  
2 the steps of :
  - 3 A. maintaining a list having a plurality of entries, each entry  
4 comprising the current Internet protocol address for a user  
5 connected to the Internet; and
  - 6 B. in response to selection of one of the list entries by a  
7 requesting user, providing the corresponding Internet  
8 protocol address of the selected entry to the requesting user.
  
- 1 2. A method for locating users having dynamically assigned network  
2 protocol addresses over a computer network, the method  
3 comprising the steps of:
  - 4 A. maintaining in a computer memory, a compilation of entries,  
5 each entry comprising a network protocol address of a user  
6 process connected to the computer network;
  - 7 B. in response to identification of one of the entries by a  
8 requesting user process, providing the network protocol  
9 address of the identified entry to the requesting user  
10 process.
  
- 1 3. The method of claim 2 wherein the network protocol address is an  
2 Internet protocol address.
  
- 1 4. The method of claim 2 further comprising the step of:  
2 C. modifying the compilation of entries.
  
- 1 5. The method of claim 4 wherein step C further comprises:

- 1 C.1 modifying an entry of the compilation upon the occurrence of  
2 a predetermined event.
- 1 6. The method of claim 5 wherein the predetermined event  
2 comprises notification from a user process that the user process is  
3 coupled to the network.
- 1 7. The method of claim 5 wherein the predetermined event  
2 comprises expiration of a predefined time interval since notification  
3 from the user process.
- 1 8. In a computer system having a display and audio transducer, the  
2 computer system coupled to other computers and a server over a  
3 computer network, the apparatus for establishing a point-to-point  
4 communication link comprising:  
5 a. means for transmitting, from the first process to a server, a  
6 query as to whether a second process is connected to the  
7 computer network;  
8 b. means for receiving a network protocol address of the  
9 second process from the server when the second process is  
10 connected to the computer network; and  
11 c. means, responsive to the network protocol address of the  
12 second process, for establishing a point-to-point  
13 communication link between the first process and the second  
14 process over the computer network.
- 1 9. The computer apparatus of claim 8 further comprising:  
2 d. means for receiving audio data and transmitting the audio  
3 data to the second processor over the established point-to-

1 point communication link.

- 1 10. In a computer system, the computer system having an audio  
2 transducer and a display device and being operatively coupled to  
3 other computer system and a server over a computer network,  
4 apparatus for establishing a point-to-point communication link  
5 comprising:
- 6 a. means for transmitting an E-mail signal containing a network  
7 protocol address from the first process to a second client  
8 process over the computer network;
  - 9 b. means for receiving a second network protocol address from  
10 the second process over the computer network; and
  - 11 c. means, responsive to the second network protocol address,  
12 for establishing a point-to-point communication link between  
13 the first process and the second process over the computer  
14 network.

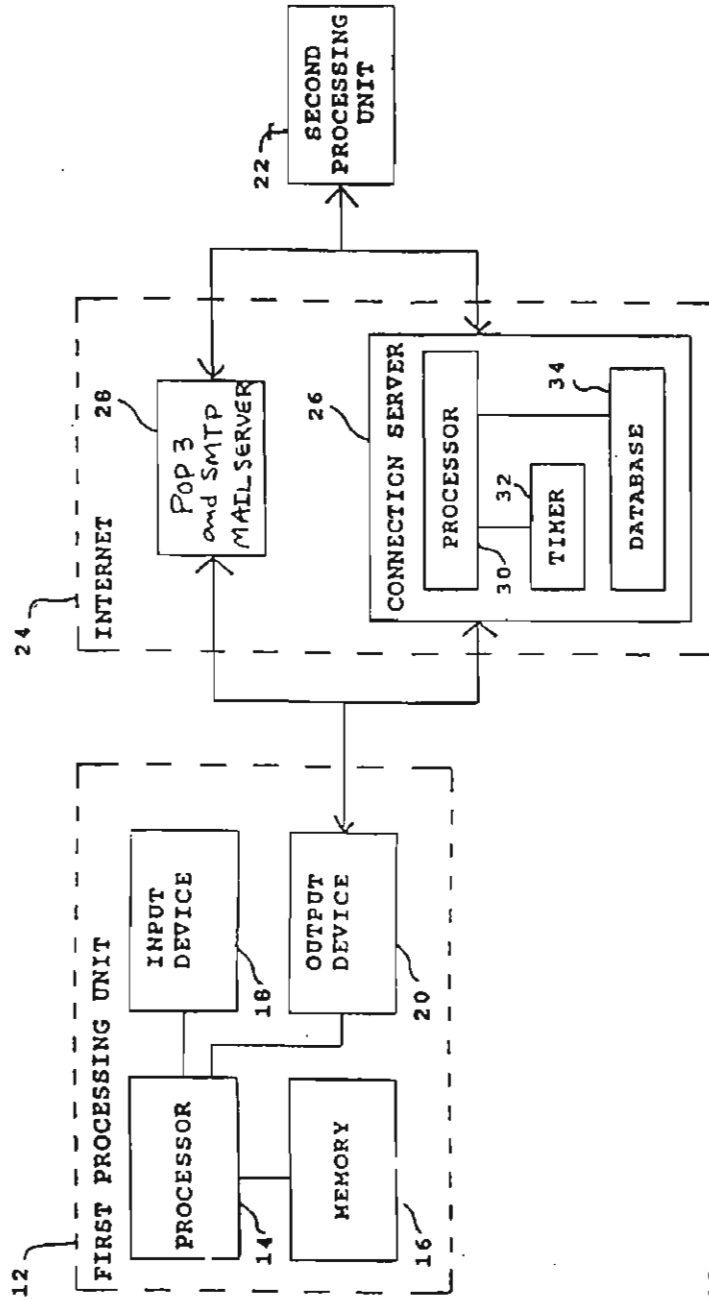

10

FIG. 1



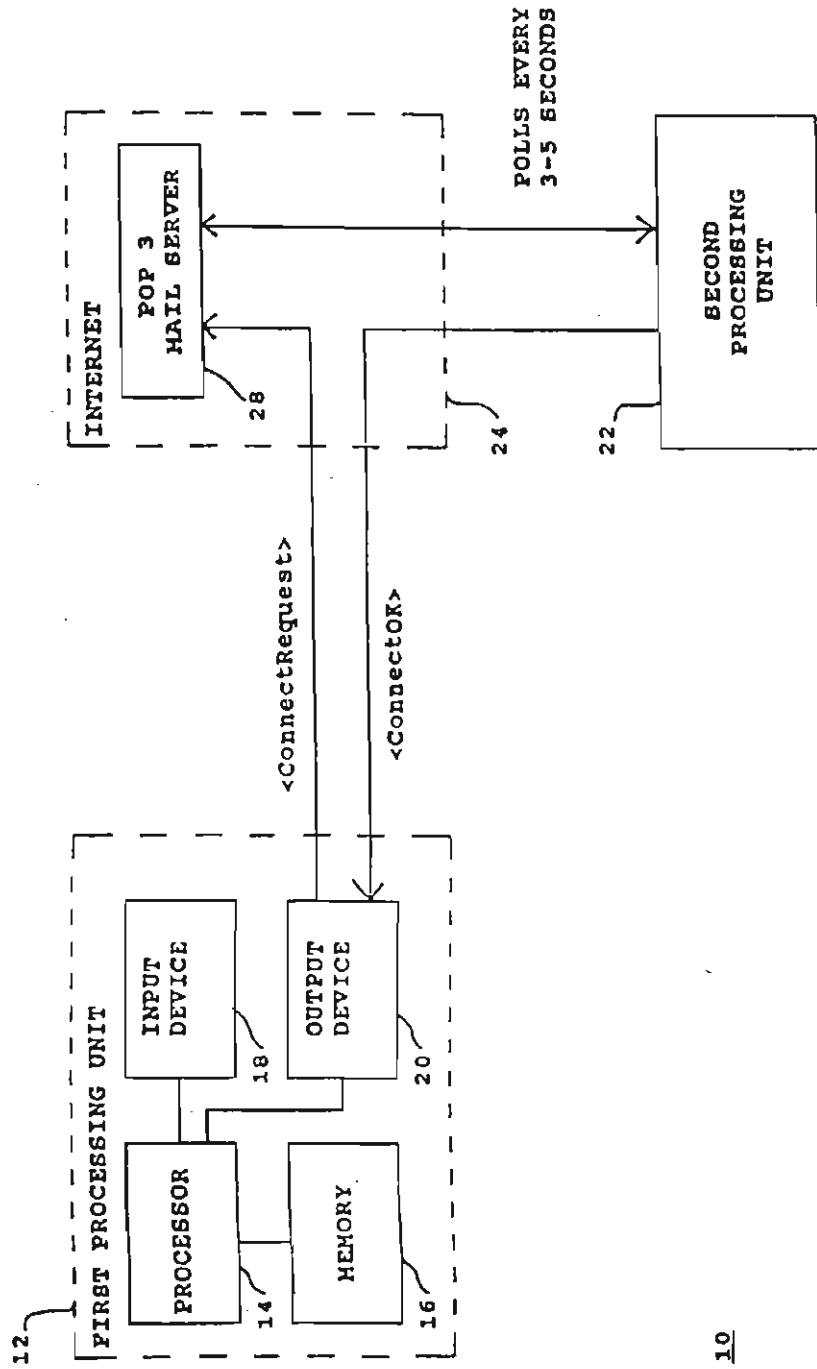

10

FIG. 2

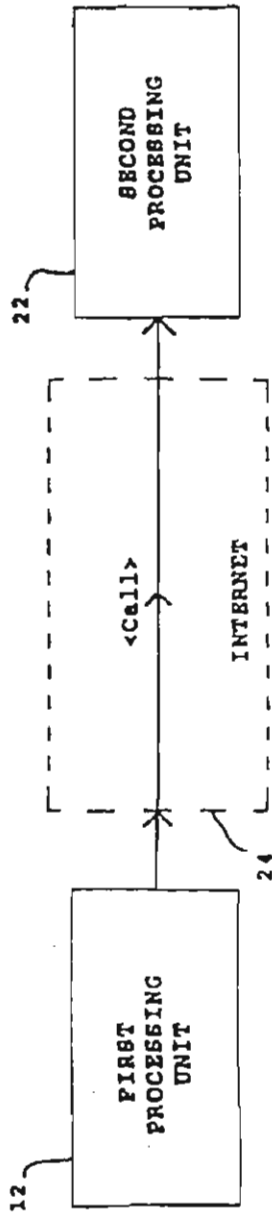

FIG. 3

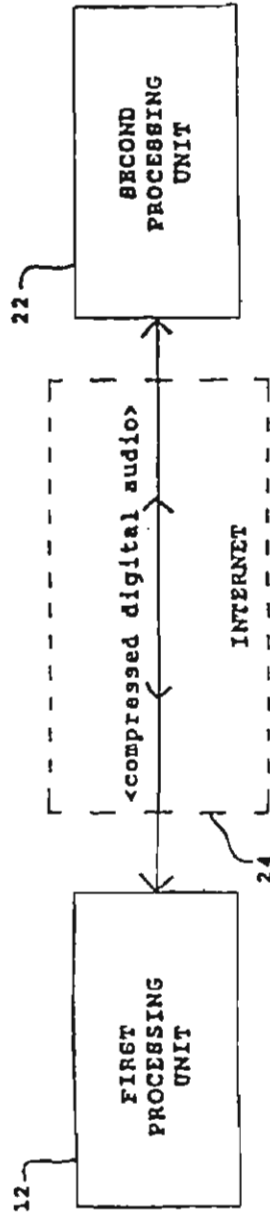

FIG. 4

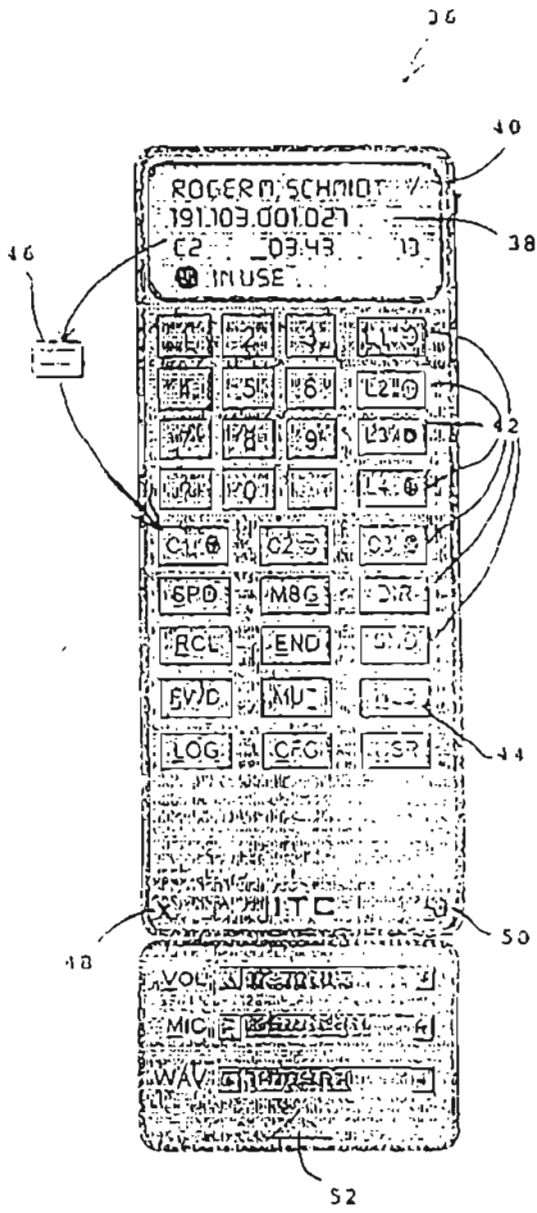

FIG. 5

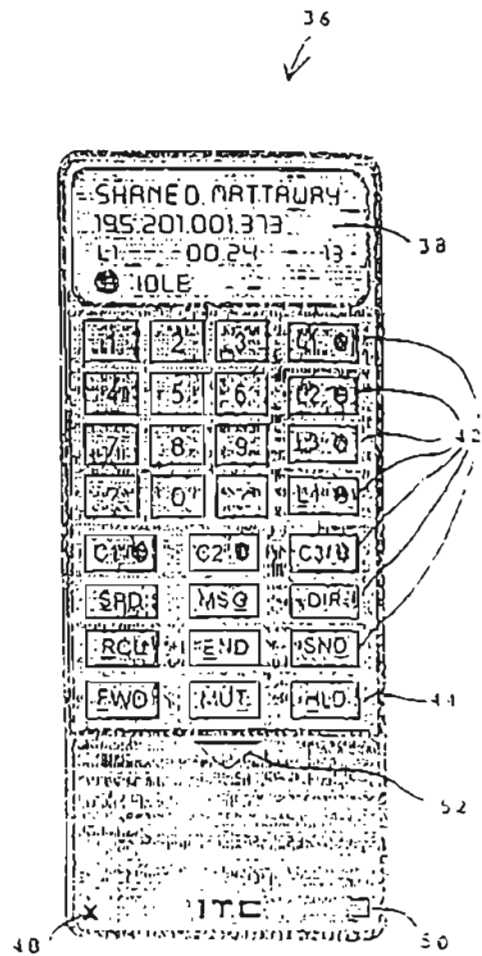

FIG. 6

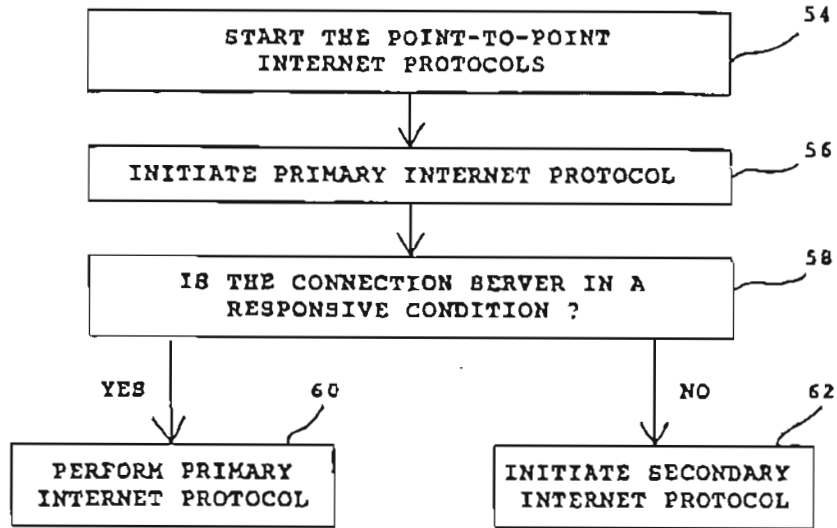

FIG. 7

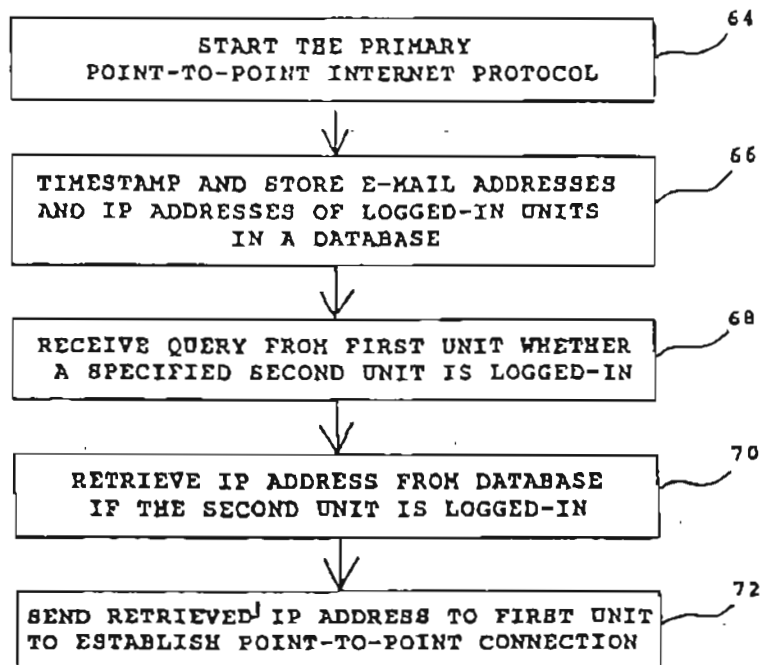

FIG. 8

6/6

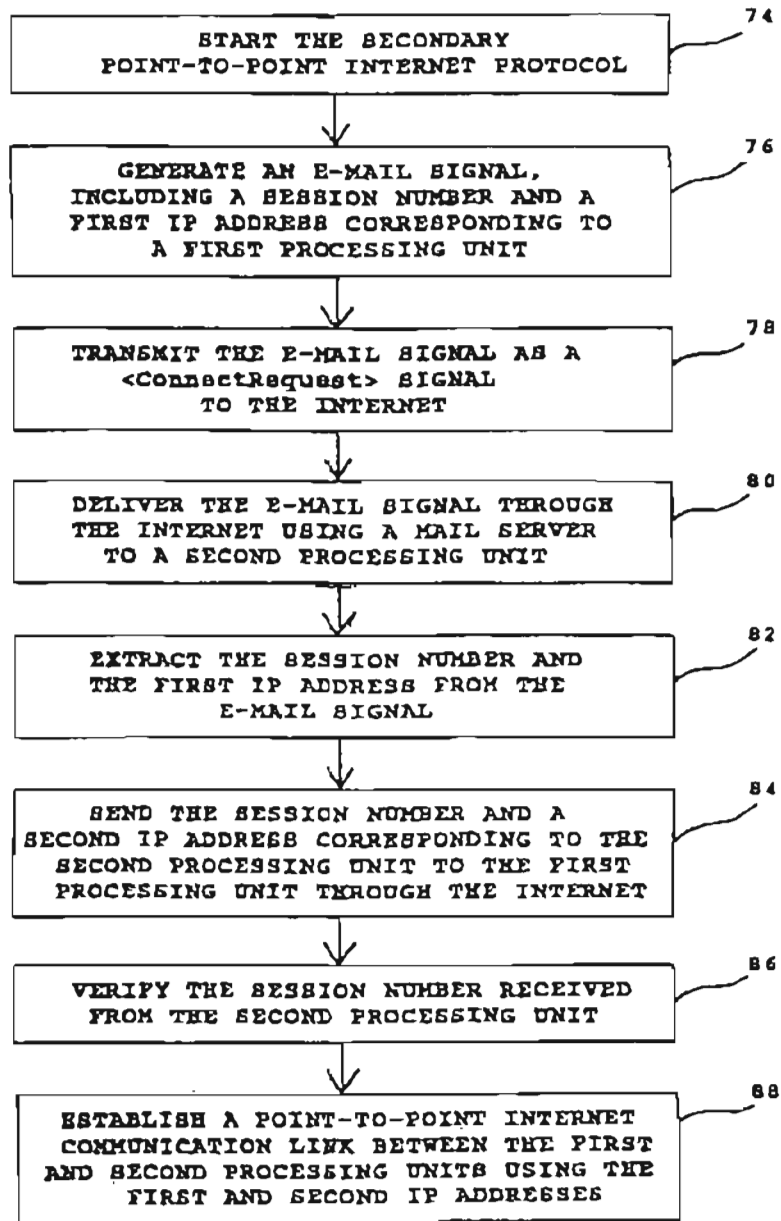

FIG. 9



INTERNATIONAL APPLICATION PUBLISHED UNDER THE PATENT COOPERATION TREATY (PCT)

<p>(51) International Patent Classification <sup>6</sup> : <b>H04M</b></p>	<p>A2</p>	<p>(11) International Publication Number: <b>WO 98/11704</b> (43) International Publication Date: 19 March 1998 (19.03.98)</p>
<p>(21) International Application Number: PCT/US97/16504 (22) International Filing Date: 12 September 1997 (12.09.97) (30) Priority Data: 08/713,077 12 September 1996 (12.09.96) US 08/832,709 11 April 1997 (11.04.97) US Not furnished 27 August 1997 (27.08.97) US (71) Applicant: DIALNET, INC. [US/US]; 148 Allston Street, Cambridge, MA 02139 (US). (72) Inventors: LEE, Don, Joon; 148 Allston Street #2, Cambridge, MA 02139 (US). YAN, Charles; 29 Knollwood Court, Burlington, MA 01803 (US). (74) Agent: GORDON, Peter, J.; Wolf, Greenfield &amp; Sacks, P.C., 600 Atlantic Avenue, Boston, MA 02210 (US).</p>		<p>(81) Designated States: AL, AM, AT, AU, AZ, BA, BB, BG, BR, BY, CA, CH, CN, CU, CZ, DE, DK, EE, ES, FI, GB, GE, GH, HU, IL, IS, JP, KE, KG, KP, KR, KZ, LC, LK, LR, LS, LT, LU, LV, MD, MO, MK, MN, MW, MX, NO, NZ, PL, PT, RO, RU, SD, SE, SG, SI, SK, SL, TJ, TM, TR, TT, UA, UG, UZ, VN, YU, ZW, ARIPO patent (GH, KE, LS, MW, SD, SZ, UG, ZW), Eurasian patent (AM, AZ, BY, KG, KZ, MD, RU, TJ, TM), European patent (AT, BE, CH, DE, DK, ES, FI, FR, GB, GR, IE, IT, LU, MC, NL, PT, SE), OAPI patent (BF, BJ, CF, CG, CI, CM, GA, GN, ML, MR, NE, SN, TD, TG).</p> <p>Published Without international search report and to be republished upon receipt of that report.</p>

(54) Title: DEDICATED SYSTEM AND PROCESS FOR DISTRIBUTED COMMUNICATION ON A PACKET-SWITCHED NETWORK

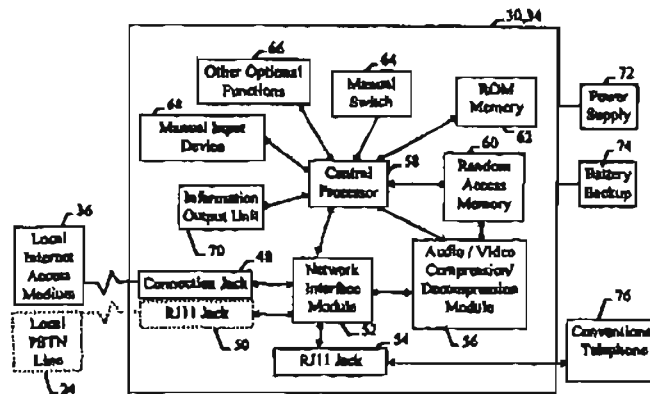

(57) Abstract

A dedicated appliance for packet-switched voice communication is provided with a mechanism to ensure that both the caller and a recipient of voice communication having a similar appliance have a connection to the packet-switched network. Such an appliance eliminates the need for complex and expensive multimedia computer systems and Internet telephony software which requires a pre-existing network connection for both parties prior to initiating communication. In one embodiment of the invention, a caller's appliance may cause a recipient's appliance to connect to the packet-switched network through the access medium of the recipient. Another mechanism which enables switching between circuit-switched and packet-switched voice communication allows for both kinds of communication to be used by the same appliance. Once connected to the network, the caller and recipient may establish a connection therebetween over the packet-switched network to permit communication. Network service providers (NSP) which provide access to the packet-switched networks for users do not need to dedicate connection ports to voice communication and therefore can allow use of any connection port for any purpose with the existing infrastructure.

*FOR THE PURPOSES OF INFORMATION ONLY*

Codes used to identify States party to the PCT on the front pages of pamphlets publishing international applications under the PCT.

AL	Albania	ES	Spain	LS	Lesotho	SI	Slovenia
AM	Armenia	FI	Finland	LT	Lithuania	SK	Slovakia
AT	Austria	FR	France	LU	Luxembourg	SN	Senegal
AU	Australia	GA	Gabon	LV	Latvia	SZ	Swaziland
AZ	Azerbaijan	GB	United Kingdom	MC	Monaco	TD	Chad
BA	Bosnia and Herzegovina	GE	Georgia	MD	Republic of Moldova	TG	Togo
BB	Barbados	GH	Ghana	MG	Madagascar	TJ	Tajikistan
BE	Belgium	GN	Guinea	MK	The former Yugoslav Republic of Macedonia	TM	Turkmenistan
BF	Burkina Faso	GR	Greece	ML	Mali	TR	Turkey
BG	Bulgaria	HU	Hungary	MN	Mongolia	TT	Trinidad and Tobago
BJ	Benin	IE	Ireland	MR	Mauritania	UA	Ukraine
BR	Brazil	IL	Israel	MW	Malawi	UG	Uganda
BY	Belarus	IS	Iceland	MX	Mexico	US	United States of America
CA	Canada	IT	Italy	NE	Niger	UZ	Uzbekistan
CF	Central African Republic	JP	Japan	NL	Netherlands	YN	Yan Nam
CG	Congo	KE	Kenya	NO	Norway	YU	Yugoslavia
CH	Switzerland	KG	Kyrgyzstan	NZ	New Zealand	ZW	Zimbabwe
CI	Côte d'Ivoire	KP	Democratic People's Republic of Korea	PL	Poland		
CM	Cameroon	KR	Republic of Korea	PT	Portugal		
CN	China	KZ	Kazakhstan	RO	Romania		
CU	Cuba	LC	Saint Lucia	RU	Russian Federation		
CZ	Czech Republic	LJ	Liechtenstein	SD	Sudan		
DE	Germany	LK	Sri Lanka	SE	Sweden		
DK	Denmark	LR	Liberia	SG	Singapore		
EE	Estonia						

**DEDICATED SYSTEM AND PROCESS FOR DISTRIBUTED  
COMMUNICATION ON A PACKET-SWITCHED NETWORK**

**Field of the Invention**

5           The present invention is related to communication over packet-switched networks. The present invention is more particularly related to voice communication using such networks.

**Background of the Invention**

          Voice communication typically uses a circuit-switched network. Such a network is  
10 maintained by regional and long distance telecommunication carriers, and typically provides a dedicated channel for each connection established between subscribers for voice communication. A circuit-switched network is expensive to operate, which in turn causes users to incur significant charges, particularly for long distance calls. Additionally, each connection requires a direct path between two locations, typically determined using a complex algorithm.  
15 Additionally, each connection is recorded for billing purposes. The overhead incurred for billing is a substantial portion of the cost in maintaining the network.

          Recently there has been an increased interest in the use of packet-switched networks for voice communication. In particular, a global network of computers using a packet-switched network, commonly known as the Internet, has been the platform for some computer software  
20 that allows for voice communication between two or more individuals connected to the Internet.

          Because packet-switched networks are less expensive to use and more versatile than circuit-switched networks, there is an increasing interest in developing their use for voice and video communication. However, there are some drawbacks to packet-switched networks. First, packet-switched networks are used primarily for general data communication. At present, it  
25 generally does not guarantee reliable real-time performance, particularly for voice communication. The lack of reliable real-time communication results in degradation of the quality of voice data transmitted over the network. These problems will eventually be overcome as technology and communication standards develop. A second problem is that both users who wish to communicate by voice over a packet-switched network have to have operative  
30 connections to the network. It is not possible at the present time to initiate voice communication over the packet-switched network without each party establishing their own connection to the network prior to communication being initiated by one of the parties. This requirement is in stark contrast to the circuit-switched networks where the recipient of a conventional telephone



call is notified, for example, by ringing of a telephone.

Some current proposals for using packet-switched networks for telephone communication either are computer software (e.g., the Internet Phone software from VocalTec of Northvale, New Jersey and the WebPhone software by Netspeak of Boca Raton, Florida) which are loaded onto a general purpose multimedia computer system with a modem or use centralized systems known as "hop-off" servers which translate between packet-switched data packets and electronic voice signals expected by a circuit-switched network and which generate outgoing phone calls through a regular telephone network (also called a plain old telephone system (POTS)). Some of the problems with the first kind of computer software are that the cost, complexity, and inconvenience of using the computer and the software is significant. To receive incoming calls, the computer system needs to be continuously, on wasting much electricity, and needs to have a continuous link to the Internet which can incur online charges from an access provider. Furthermore, the computer system uses much of the computer's central processor power that could otherwise be used for increasing performance on other software applications. The problem with the second kind of system is that it has operations costs similar to those associated with circuit-switched networks for general-purpose consumer and business use. In particular, current service providers to the Internet might have to dedicate bandwidth and connection ports for the sole purpose of providing voice communication and these dedicated servers are not useful for other kinds of data communication. Additionally, it is becoming increasingly likely that individual consumers may have one or more means to access the packet-switched network via various media such as cable television lines, optical fibers, wireless, digital subscriber lines, other than telephone lines. Having such versatility to easily switch among several options to conduct voice communication through any of these media would benefit consumers and businesses.

25

#### Summary of the Invention

A dedicated appliance for packet-switched voice communication is provided with a mechanism to ensure that both the caller and a recipient of voice communication having a similar appliance has a connection to the packet-switched network. Such an appliance eliminates the need for complex and expensive multimedia computer systems and Internet telephony software which requires a pre-existing network connection for both parties prior to initiating communication. In one embodiment of the invention, a caller's appliance may cause a

30

recipient's appliance to connect to the packet-switched network through the access medium of the recipient. Another mechanism which enables switching between circuit-switched and packet-switched voice communication allows for both kinds of communication to be used by the same appliance.

5           Once connected to the network, the caller and recipient may establish a connection therebetween over the packet-switched network to permit communication. Network service providers (NSP) which provides access to the packet-switched networks for users do not need to dedicate connection ports to voice communication and therefore can allow use of any connection port for any purpose with the existing infrastructure.

10           Accordingly, one aspect of the invention is a communication system using a packet-switched network. The communication system includes a first network access system for providing access to the packet-switched network. A second network access system also provides access to the packet-switched network. A first appliance has a mechanism for connecting to the first network access system through a first access medium, and sends and receives packets  
15 through this connection to the packet-switched network. A second user appliance has similar capabilities. In addition, the second user appliance has mechanisms for causing the first appliance to connect to the packet-switched network through the first network access system. The first and second appliances then can send and receive packets to and from one another through the packet-switched network.

20           Another aspect of the invention is an appliance for communication using a packet-switched network. The appliance connects to a first access medium, and in turn connects to a first network access system connected to the packet-switched network using the access medium. The appliance includes a mechanism for causing another appliance to be connected, through a second access medium, to a second network access system connected to the packet-switched  
25 network. After the connection of the other appliance is made, the two appliances may send and receive packets through the packet-switched network to each other.

          In one embodiment of the invention, the first appliance is caused to connect to the packet-switched network by first connecting with the first appliance using a public switched telephone network (PSTN) encompassing a local exchange carriers (LEC) and an inter-exchange carrier  
30 (IXC) then instructing the first appliance to connect to the first network access system using its access medium. In another embodiment of the invention, the first appliance is caused to connect to the packet-switched network by the second appliance dialing the first appliance using PSTN

and then having the first appliance use the caller identification service of the LEC to connect to the first network access system using its access medium. In another embodiment of the invention, the first appliance is caused to connect to the packet-switched network by the second appliance identifying the first network access system and then by instructing the first network access system to connect with the first appliance through the access medium connected to the first appliance. In another embodiment of the invention, the first appliance is caused to connect to the packet-switched network by the second appliance identifying and instructing the first network dial-out service provider to inform the first appliance to connect through the access medium connected to the first appliance. In yet another embodiment, the first appliance is continuously connected to the first network access system and is caused to connect to the packet-switched network by the second appliance. In any embodiment of the invention, the appliance also way initiate any conventional calls using the PSTN.

Another aspect of the invention, which may be used in combination with other aspects of the invention, is a database system for storing information supporting a communication system using a packet-switched network, wherein first and second appliances are connected through first and second access media to first and second network access systems which are connected to the packet-switched network. The database stores user information for each of the first and second appliances, such as a first unique identifier indicating an address for the appliance accessible using the packet-switched network and a second unique identifier indicating an access mechanism for establishing a connection over an access medium between the first and second network access systems and the first and second appliances. The database responds to queries to return one of the first and second unique identifiers as well as any other pertinent user information.

In another aspect of the invention, an appliance selects whether a conventional telephone call is made or whether the call is made over the packet-switched network. In another aspect of the invention, the connection to the packet-switched networks made after the identifier of the recipient is input to the appliance by the caller.

#### **Brief Description of the Drawings**

In the drawings,

Fig. 1 is a block diagram of a voice communication system in accordance with the present invention:

Fig. 2a is a more detailed block diagram of one embodiment of the telephone appliance shown in Fig. 1;

Fig. 2b is a more detailed block diagram of another embodiment of the telephone appliance shown in Fig. 1;

5 Fig. 3 is a more detailed block diagram of the central database (CBD) shown in Fig. 1;

Fig. 4 is a more detailed diagram of the dedicated communication facility (DCF) as shown in Fig. 1;

Fig. 5a is a flow chart of one embodiment of a process for making an Internet telephone call using the voice communication system of the present invention;

10 Fig. 5b is a flow chart of another embodiment of a process for making an Internet telephone call using the LEC caller identification service with the voice communication system of the present invention;

Fig. 6a is a flow chart of an embodiment of a process for using the voice communication system of the present invention using dial-out possibilities with existing network service  
15 providers;

Fig. 6b is a flow chart of another embodiment of a process for using the voice communication system of the with dedicated dial-out service providers;

Fig.7 is a flow chart of an embodiment of a process for using the voice communication system of the present system with a continuous link to a packet-switched network;

20 Fig. 8 is a flow chart describing the process to check if a recipient's telephone number has an appliance.

Fig. 9 is a flow chart describing how the telephone appliance contacts a local Internet service provider to establish a PPP/SLIP link;

Fig. 10 is a flow chart describing how the central database is updated;

25 Fig. 11 is a flow chart describing how the recipient's dedicated communication facility makes an outgoing telephone call;

Fig. 12 is a flow chart describing query processing in the central database;

Fig. 13 illustrates an example information packet for the central database; and

30 Fig. 14 is a diagram illustrating an example data portion of a packet containing one or more type length and value entities.

### Detailed Description

The present invention will be more completely understood through the following detailed description which should be read in conjunction with the attached drawing in which similar reference numbers indicate similar structures.

5 Referring now to Fig. 1, the voice communication system of the present invention is shown in comparison to a conventional voice communication system. A conventional system includes a conventional telephone 20 connected to a telephone network 22. The telephone network 22 includes a local exchange carrier (LEC) 24 connected to an inter-exchange carrier 26 (IXC) (i.e., long distance carrier) and a second LEC 28. The network 22 allows users of  
10 conventional phone 20 to contact a recipient using conventional telephone 20' over long distances. In one embodiment of the present invention, an appliance 30, described in more detail below, is used to access a packet-switched network 32, such as the Internet, to contact a recipient having another similar appliance 34 or any compatible systems abiding to International  
15 Telecommunications Union (ITU) multimedia communications standards for packet-switched communication, such as H.320, H.323 and H.324. While the invention is described herein with reference to the Internet, it should be understood that it is generally applicable to any packet-switched protocols and networks that allow for packet-switching capabilities, included but not limited to, TCP/IP, IPX, ATM, Ethernet, ISDN, and PSTN, using a variety of communications standards, including, but not limited to, ITU standards H.320, H.323 and H.324. The network  
20 32 is accessed by appliances 30 and 34 via network access media 36 and 38. Such access may be provided over several possible access media. Such access media include, but are not limited to POTS, cable television cable lines, electric power lines, optical fibers, wireless, satellite, digital subscriber lines, etc. The term "access media" as used herein is intended to mean any mechanism for access to the network, whether analog, digital, optical or wireless. The access  
25 media allow access to a public or private network service provider 40 or 42 such as an Internet service provider, which may be local to each user. The network service providers 40 and 42 access a packet-switched network 44, such as a large global network, commonly called the Internet, and have access to a central database 46, described in more detail below, of users of the appliances 30 and 34 or an otherwise compatible system which may utilize such a database.

30 Using the conventional communications network 22, the user 20 typically has access charges incurred for access to the local telephone company, and per call access charges due to a long distance carrier that supports the public switched telephone network. In the present

invention, the users of appliances 30 and 34 typically incur charges for obtaining access through a local network access medium 36 and 38 such as the local telephone company and/or a network service provider 40 and 42.

The appliance 30, 34 will now be described in connection with Figs. 2a and 2b. One form of packaging of the appliance may be a separate box that connects between a connector to the network access medium and a conventional telephone 76 for which the circuitry is shown in Fig 2a. This form of packaging may be integrated with other appliances such as cable television converter boxes and high-definition digital televisions to provide integrated telephony services using cable Internet access or video telephony using a small window image on a high-definition television (HDTV) set.

Another form of packaging of the appliance may be like a conventional telephone for which the circuitry shown in Fig. 2b is same as in Fig. 2a except for numeric keypad 66', handset with a transmitter 78 (e.g., microphone) and receiver 80 (e.g., speaker), and an integrated conventional telephone interface electronics 77. Yet another form of packaging could be a single household model for allowing all phones connected to the main household phone line to use Internet telephony.

The appliance has an Internet access jack 48 to permit connection to a network service provider. The Internet access jack can also accommodate other network connections depending on the network access medium such as coaxial cable connector for cable access or a conventional phone jack such as an RJ-11 connector if connecting to an LEC via a POTS modem. If the connection jack 48 is not a conventional phone jack, a conventional phone jack 50 such as an RJ11 jack can be made available for connection to the PSTN line for making conventional calls. Such means of network and phone connection allows the appliance to function just like a regular phone for local phone calls, but for long-distance phone calls, which may be detected by examining the telephone number of the appliance users from the central database 46, it may connect automatically into the network, if there is an appliance user corresponding to the telephone number, or into an IXC if there is no appliance user corresponding to the telephone number.

The appliance does not require both parties to be already linked to the network to initiate communication. At least five modes of operation may be provided for establishing a connection with the recipient. One mode uses a conventional long-distance telephone call to cause the recipient's appliance 34 to initiate a connection with its own network service provider, as

described in more detail below. A second mode causes the recipient's appliance to connect with its own network service provider by using caller identification of the caller as described in more detail below. A third mode causes the network service provider local to the recipient to initiate the connection with the recipient, as described in more detail below. A fourth mode causes a  
5 network dial-out service provider local to the recipient to initiate the connection with the recipient as described in more detail below. A fifth mode causes the caller's appliance to directly connect to the recipient's appliance with a continuous connection to the network service provider as described in more detail below. These modes of operation may be compatible with each other depending on the available type of network access by each of the calling parties. The software  
10 for causing these operation modes can also be adapted for running on conventional computer systems running on various operating systems for example Unix, Microsoft's Windows, IBM OS/2, and Apple operating system.

The appliance 30, 34 in Fig.2a and 2b shows two possible embodiments of the invention. The appliance 30, 34 includes a network interface module 50 and 50' such as a POTS modem for  
15 establishing communication with the network access medium 36 through connection jack or port 48, a central processor, a random access memory 60 and 60', digital signal processor chip 56 and 56' to conduct dedicated audio and/or video compression and decompression, a manual input device 68 and 68' such as a keypad, and an information output unit 70 and 70' such as an LCD display and/or voice messaging software system directly to a receiver 80' or to the handset of a  
20 conventional telephone 76 to inform the appliance user of any necessary status or decision requests.

A power supply 72 and 72' provides power to the appliance 30 and a back-up battery 74 and 74' maintains operation during a power outage. Other features 66 and 66' may also be included such as those for data encryption and decryption, speaker phone, caller ID, call waiting,  
25 conferencing, and voice mail. A manual switch 64 and 64' or software setup change allows for switching between operation modes, of which three are described in more detail below. The appliance operates in full-duplex mode to allow both parties to talk at once.

The central processor unit 58 and 58' may be a microprocessor such as Motorola 68000 or Intel 486 chip. The central processor performs all high-level controls such as providing a  
30 point-to-point protocol (PPP) or Serial Line Internet Protocol (SLIP) for TCP/IP (Transmission Control Protocol/Internet Protocol) communications, protocols of ITU standards such as H.323 for real-time multi-media communications, and may also conduct encryption/decryption

functions. The appliance uses the random access memory 60 and 60' to temporarily store operation code and data during operation. The network interface module 52 and 52' may be a stand-alone chip, chipsets, and/or other means that provide communication between the local communication medium 36 such as but not limited to POTS, ISDN, wireless such as satellite or cellular, or cable television networks. A POTS modem may be implemented using a commercially available modem chipset such as those produced by Rockwell which are prevalent in the market. For cable Internet access, a cable modem by Motorola and an Ethernet interface chipset can be used as the network interface module. These network interface modules may be designed to be modular such as using the PCMCIA standard so that the appliance can be easily modified for interfacing to the desired choice of network access.

A read only memory (ROM) chip 62 and 62', such as programmable erasable read only memory (EPROM) chip or Flash ROM chip, contains high-level control computer program code to manage all the other devices and deal with network protocols and standards. Flash ROMs provide the added benefit for automatic field upgradability for quick and easy software updates and patches which can be easily performed by the user. Such control code is described in more detail below by the flowcharts describing the appliance operation. The memory chip 62 and 62' may also be programmed to contain a unique network address, a phone number of a local network access provider, memory cache to store information such as recipients' network addresses and telephone numbers, long-distance calling codes that are currently serviced by network service providers for communication with such an appliance, and networking information such as gateway and authentication information. These user setups will be discussed in detail.

Audio compression and decompression may be provided by the central processor 58 and 58' or by dedicated audio/video compressors/decompressors 56 and 56' such as the TrueSpeech CT8020 Digital Signal Processor (DSP) chip available from DSP Group, Inc. of California or by general purpose DSP chips such as Analog Devices' AD21xx family of DSP chips or Texas Instruments' TMS320 family of DSP chips that can be programmed with audio or video compressors and decompressors (codecs) licensed or sold by numerous vendors, such as Lucent Technologies, Intel, and DSP Group. Audio codecs can comply to the following International Telecommunications Union (ITU) standard such as G.711, G.722, G.728, G.723, G.723.1, and G.729. G.723 and G.723.1 standards are preferred for low bit-rate voice communications on low bandwidth network access medium such as POTS. Video compression and decompression may



comply to the following ITU standard such as H.261 and H.263. H.263 is preferred for low bit-rate video communications on low bandwidth network access media.

Both the audio and video codec standards mentioned support ITU H.32x multimedia communication standards. The use of these ITU standards allow the appliance to be  
5 interoperable with other computer systems or software that use the same standards.

The central processor in connection with the network interface module operate to establish a network connection such as TCP/IP through the network access medium. The multimedia communications standard used for network communications can include ITU standards such as H.320, H.323, and H.324.

10 When the connection is established, incoming packets are processed by the DSP chip as directed by the central processor to convert analog audio signals from the transmitter 78 usually a microphone for voice, a charge coupled display (CCD) camera, or the handset of a conventional phone 76 and output digital audio and/or video information to the network. The DSP chip also converts the digital audio information to an analog signal to be output to the receiver 70 such as a  
15 speaker or an LCD or television video display or to the handset of a conventional phone 76. The central processor 58 and 58' and the DSP chip can produce packets abiding by a specific communication and network protocols to be transferred via the network interface module 52 and 52' and the local network access medium 36 to the other party. It is also possible to integrate the voice compression & decompression, the high-level central processing functions, and modem  
20 functions controlled by a single DSP chip applications specific integrated circuit (ASIC) chip eliminating the need for dedicated chips.

The central database (CDB) 46 will now be described in more detail in connection with Fig. 3. This database is directly connected to a packet-switched network with a static network address as a place of information reference to allow lookup of appliance users or compatible  
25 system users as part of the call connection process. A dedicated CDB comprises of a server 80, such as a Digital Alpha server and a fast database 82, such as those commercially-available from Oracle Corporation. The dedicated database also should include a router 84, such as those available from Cisco Systems or Bay Networks, which connects to the network using a high-speed access medium such as a T1 or T3 line connection to network backbones. Duplicates 80'  
30 and 82' of the server and database located physically in a geographically different location provides for redundancy for fast access or in case one system becomes inoperative. Databases also may reside at any available network service provider.

The information stored in both the primary and redundant databases are synchronized at regular intervals using standard coherency techniques to maintain the same information. The user information stored in the database includes a unique identifier such as the user's telephone number. The slot for this value in the database is generally permanent for all users of appliances or a compatible appliance or system that is allowed to use this communication system. The value  
5 may be modified for example, if a user changes location. The database also includes for each user an identifier which indicates an address for the user when the user's appliance is connected to the packet-switched network. This identifier may be dynamic or fixed, depending on how the addresses are assigned by the network. These network identifiers are used to establish call  
10 connection between two or more users. The database may also include other useful or pertinent information for each user such as a subscriber's name, residential address, e-mail address, network service provider's IP address, and billing information.

As the user base increases, the CDBs may be distributed geographically to maximize the efficiency of CDB access and for redundancy. Multiple CDBs can be synchronized to make sure  
15 that the databases contain the same information for redundancy. It is also possible to have distinct databases with respective redundant databases for separate groups of users in different locations especially as subscriptions increase. Queries can be processed, for example, by multicasting or broadcasting them to each database.

The following is a scenario of using distinct databases for specific regions. Each  
20 database, wherever located world-wide, contains the network addresses of every CDB and the information of every appliance user in that local region. If a new CDB is installed, all existing CDBs are updated with the new CDB's IP address. If a caller in one location calls a recipient at a remote location and the recipient's information is unavailable when the caller's appliance contacts the local CDB, the CDB associates the long-distance dialing codes (e.g. country and  
25 area code) with the remote CDB's network address to allow the caller's appliance to establish a link with the remote CDB at the recipient's location. The remote CDB may then take over to continue the process of linking the communication channel between the caller and recipient. In instances where some other recipient's information is used which does not provide sufficient locale information such as the recipient's Internet username or domain name, the CDB can  
30 multicast or broadcast the recipient's information to all other CDBs in order to identify the locale of the recipient. Once the remote CDB has been identified, it can then take over to continue the process of establishing the communication channel between the caller and the recipient.

The central database responds to queries from dedicated communication facilities (described below), individual appliances, or any otherwise compatible system that complies to a database query protocol. The response includes packets of stored user data when a match is found. The database permits users with dynamically assigned network addresses to be located. 5 Additionally, this database allows one person to request a connection with another person who is not presently connected to the network. The database also can identify a phone number that allows the network service provider of the individual to make an outgoing phone call from the network to the local individual.

Referring now to Fig. 4, each network service provider supporting this voice 10 communication system also should include functions of a dedicated communication facility (DCF) in order to support a mode of operation where a connection to a recipient appliance is initiated by the service provider. Each DCF may be comprised of a router 90 which may be connected via a high speed access medium (e.g., T1 or T3) to the network, a server 92, remote and network access hardware 94, switch 96 to access the access medium used by the user of 15 appliance, such as a telephone switch, and POTS modem pools 98.

The construction of the system shown in Fig. 4 is very similar to systems used by conventional network service providers. However, most of such network service providers are not programmed to allow outgoing dial-out to subscribers using a network access medium such as POTS, ISDN or Cable. Generally, they are programmed only to respond to incoming 20 telephone calls. However, many systems may have the capability to make such outgoing phone calls. By providing additional functionality to identify an available access line, such capability may be used to initiate a telephone call with a recipient appliance 30. Such capability is useful in the second mode of operation to be described in more detail below.

A first mode of operation of this system uses a conventional long distance call via PSTN 25 for initiating a connection between the recipient and its network service provider. The process of establishing a communication channel between two appliances using this mode of operation will now be described in connection with Fig. 5a using the Internet as an example. First, the caller dials the recipient's telephone number into the appliance using a conventional telephone connected to the appliance or directly into an appliance that is integrated with a conventional 30 telephone in step 100. The appliance then determines, in step 101, whether the telephone call is long distance. If the telephone call is not a long distance call, the appliance allows for a conventional local telephone call over a plain old telephone system (POTS), in step 102. For

example, in the U.S., if the call is determined to be a long distance call from the standard telephone number prefix such as a "1" for inter-state or intra-state long-distance call or "011 + country code" for international long-distance call, the caller's appliance then checks its internal phonebook to see if the recipient's number is present (step 103) as described in detail with Fig. 8.

5 If the recipient's number is found in the phonebook, the calling process continues to step 104. The appliance establishes in step 104 a connection with the recipient's appliance by a conventional circuit-switched network call. If the call is not answered, as determined in step 105, and if no retry is to be performed (step 106), the user may hang up (step 108) by placing the phone handset on-hook. If the call is answered, the caller informs the recipient that a call with

10 this appliance is being made. For example, the caller may request that the recipient press a key on the telephone handset, such as the "\*" key or pressing a button the appliance. If the recipient cannot be connected via the appliance for any reason (step 112), a conventional toll call may be continued (step 114) and eventually terminated (step 116); the phonebook check of step 103 helps to minimize this occurrence but it is conceivable that the recipient's appliance could be

15 malfunctioning or has been disconnected. If the recipient has a properly functioning appliance, both appliances hang up (in step 118) and both parties' appliances automatically connect with their network service providers, as described in more detail below in connection with Fig. 8. They may obtain an IP address (steps 120 and 122) dynamically or may already have a static IP address assigned by their network service provider.

20 With an IP address, each party's appliance then contacts a centralized database to exchange the network addresses to each party (steps 124 and 126) referencing each party's unique identifier such as their respective telephone numbers, as described in more detail below in connection with Fig. 10. In particular, the central database is updated with the recipient's IP address in step 124 and the central database is updated with the caller's IP address in step 126.

25 The caller then queries the central database to receive the recipient's IP address in step 128, as described in more detail below in connection with Fig. 12. If the address is not found, as determined in step 130, the caller's appliance continuously tries to identify the recipient's IP address as indicated by 130 in the loop back to step 128. If one minute or other time limit. has passed, the attempts to access an IP address are terminated and the caller is informed in step 134.

30 The telephone call then may be terminated. If the IP address is found, the caller may establish contact and make a TCP connection with the recipient as indicated at step 136. Also, if the recipient is using the telephone line for general Internet access and the recipient's computer

system has a software that is compatible with the appliance running, a connection also may be attempted. If the connection is not obtained as determined in step 138, and if a retry operation is not to be performed as determined in step 140, the caller may be informed of the lack of connection in step 142 and the phone hangs up in step 144. For example, if the recipient is using  
5 a telephone line and receives a busy signal or is already on the phone with an Internet call in progress, the recipient's DCF will send a packet to the caller's appliance of the busy signal. However, upon establishing network access and a connection, the two parties may begin talking as indicated in step 146. When the call is terminated by either party by placing the handset on-hook, the TCP/IP connection is terminated in step 148 and the appliance hangs up in step 150.

10 One benefit to the first mode of operation is that it uses the existing services available from most POTS network service providers without modifying their software or hardware. Another benefit to this mode is that the caller may call from any compatible communication system rather than an appliance if the caller somehow knows that the recipient has this appliance or the caller's appliance is provided with the protocol to contact the central database and conduct  
15 outgoing PSTN toll calls to the recipient.

There are a couple of minor drawbacks with this first mode of operation. First, there could be delays possibly from one-half to around five minutes depending on distance and network traffic conditions to establish a connection. Second, every time a long-distance call is initiated, the caller may incur charges for this initial connection making frequent calls somewhat  
20 costly and reducing the freedom to call as frequently as desired. In order to minimize costs for these initial toll-calls, third-party conventional long-distance service providers may be used to allow the caller to be charged on a fraction of a second segments (e.g. one-sixth of a minute) rather than for a full minute.

A second mode of distributed operation is similar to the first mode which requires an  
25 initiating conventional long-distance call, however, the toll charge can be eliminated using a local caller identification (Caller ID) service as shown in Fig. 5b. The caller dials the recipient's number using the telephone handset in step 430. The appliance will determine if the call is local or long-distance by counting the digits and checking the calling area code. If the call is long-distance, the caller's appliance automatically looks up the internal phonebook in step 432 to  
30 check if the telephone number is associated with an appliance user. If the telephone number is determined to be associated with an appliance user, the caller's appliance will request if an Internet call is desired. The caller's appliance may be set-up to automatically select the Internet

call mode if the number dialed checks with the internal phonebook. If an Internet call is not desired, the appliance will just continue with PSTN toll call (step 436). If an Internet call is desired, the caller's appliance will dial the number and will make sure to allow for a maximum of only two or three rings (usually two) to let the recipient's appliance identify the caller's

5 telephone number (step 440). If the recipient has not yet picked up the phone and the appliance detects that the caller is an appliance user by checking its internal phonebook in step 442, the recipient's appliance will wait until the ringing stops in step 446. If the recipient picks up the phone before the appliance has had a chance to identify the caller, the operation reverts back to the first mode. If the caller is identified not to be an appliance user as determined by the internal

10 phone book, then the recipient's appliance will let the call process as a conventional one (step 444) and let the phone ring. After waiting for two or three rings, the caller's appliance will then automatically hang up in step 448 and continue with the rest of the first mode of operation beginning with step 122'. If the recipient has not yet picked up the phone and the caller has been identified as an appliance user by the recipient's appliance, the recipient's appliance will then

15 continue to establish an Internet connection with steps 120' and 124'. While the appliance attempts to establish an Internet call connection and the recipient picks up the phone, the appliance will so inform the recipient that an Internet call is in progress with the caller identified on, for example, an LCD display. The recipient will have control to cancel an Internet call in progress if so desired by pressing a button on the appliance or a button on the handset such as the

20 "\*" or "#."

Benefits to the second mode of operation is that it uses the existing services available from most POTS network service providers without modifying their software or hardware just like the first mode of operation. Another same benefit to this mode is that the caller may call from any compatible communication system rather than an appliance if the caller somehow

25 knows that the recipient has this appliance or the caller's appliance is provided with the protocol to contact the central database and conduct outgoing PSTN toll calls to the recipient. However, one major disadvantage of the caller being charged for the initial PSTN toll call associated with the first mode of operation is reduced or eliminated. The second mode of operation also eliminates the need for the recipient to intervene by picking up the handset and pressing a button

30 to initiate an Internet call as in the first mode of operation. The second mode of operation increases the ease of establishing an Internet call and also helps to reduce PSTN long-distance charges even further.

A third mode of distributed operation is used when network service providers have the ability to call out to the recipient via its network access medium, with similar capabilities of a DCF, for example, as shown in Fig. 4. This mode of operation will now be described in connection with Fig. 6. With this embodiment, the appliance is configured with a local DCF  
5 telephone number, however assigned, or other mechanism to access the network. The customer information including at least the subscriber's telephone number and DCF's network address may then be transferred to the central database (CDB) of subscribers and/or maintained on a DCF database.

The flow of information in the third mode of operation will first be described using the  
10 Internet protocol as an example. When a caller attempts to make a long-distance call, the appliance automatically accesses a local DCF or an NSP (since an outgoing call to the caller is unnecessary) by means of the local network access medium to gain network access to the packet-switched network via for example a standard PPP/SLIP and authentication. When connection to the DCF/NSP is established, the caller's appliance sends a query packet (described below)  
15 containing the recipient's telephone number or other distinct identification information such as a residential address, IP address, electronic mail address, to initiate a long-distance call.

Upon determining at least the recipient's DCF network address, the caller's appliance, caller's DCF/NSP, or the CDB contacts the recipient's DCF to transmit an information packet (described below) that contains the recipient's local telephone number or other information such  
20 as the caller's network address. To minimize delays, one method is to have the CDB directly send the recipient's telephone number and caller's network address directly to the recipient's DCF. However, selected information, its point of origin and its transfer method may vary among different implementations.

With the recipient's local telephone number, the recipient's DCF then makes an outgoing  
25 call to authenticate and to establish network access via PPP/SLIP if using POTS with the recipient's appliance. Authentication may be made by the DCF prior to making the outgoing call if the recipient's information received is sufficient for such pre-authentication in order to minimize delays.

The following will describe a few methods of initiating a communication channel through  
30 a packet-switched network. In one method, if the recipient answers the call and the recipient's appliance is provided with the caller's network address by a CDB or its DCF, the recipient's appliance may directly contact the caller's appliance with the caller's network address to initiate

a communication channel. In another method, the recipient's appliance or DCF sends an information packet containing the recipient's network address to the caller's appliance upon which the caller's appliance initiates the communications channel using the recipient's network address. Whichever way, a communication link between the caller and the recipient may be  
5 established to begin transmitting information packets over the network.

One embodiment of the data flow associated with the third mode of operation will now be described in more detail in connection with the flow chart of Fig. 6a. In particular, the caller dials the recipient's telephone number into the appliance using a conventional telephone connected to the appliance or directly into the appliance integrated with a conventional telephone  
10 in step 200. The appliance then determines whether the telephone call is long distance, as determined in step 202. If the telephone call is not a long distance call, the appliance makes a local telephone call over a plain old telephone system (POTS), in step 204. If the call is determined to be a long distance call, the caller's appliance checks its internal phonebook to see if the recipient's number is present (step 205) as described in detail with Fig. 8. If the recipient's  
15 number is found in the phonebook, the calling process continues to step 206. The caller's appliance automatically dials a local network service provider (NSP) or DCF to establish a PPP/SLIP link (step 206), as described in more detail below in connection with Fig. 9. If a PPP/SLIP link is not established as determined in step 208, a retry may be performed in steps 210 and 206 or the appliance or caller may hang up in step 212. If a PPP/SLIP link is  
20 established, the caller's appliance sends a packet with the recipient's access information to the local central database (step 214) and queries the central database for the IP address of the recipient's dedicated communication facility step 216. This step is described in more detail below in connection with Fig. 12. If the IP address of the recipient's dedicated communication facility is not found, as determined in step 218, the caller may be given an option to make a  
25 conventional toll call in step 220. If no toll call is to be made, the appliance or caller hangs up in step 222. Otherwise, a toll call may be made through a conventional public switched telephone network in step 224. When the call is completed, the caller hangs up in step 226.

If the caller connects to the network and identifies the IP address of the recipient's dedicated communication facility, the appliance then sends a packet with a caller's IP address and  
30 the recipient's access information, e.g., its telephone number, to the recipient's dedicated communication facility in step 228. This information allows the recipient's DCF to connect with the recipient's appliance over the recipient's network access medium, for example, by making a



DOSP is not found, as determined in step 518, the caller may be given an option to make a conventional toll call in step 520. If no toll call is to be made, the appliance or caller hangs up in step 524. Otherwise, a toll call may be made through a conventional public switched telephone network in step 522. When the call is completed, the caller hangs up in step 514.

5           If the caller connects to the network and identifies the IP address of the recipient's DOSP, the caller's appliance then sends a packet with the recipient's access information, e.g., its telephone number, to the recipient's DOSP in step 526. This information allows the recipient's DOSP to connect with the recipient's appliance over the recipient's network access medium, for example, by making a telephone call, to establish a point-to-point protocol link in step 528.

10          During this process, the caller may be informed of the call status with phone ringing sounds on the recipient's telephone. This process is described in more detail below in connection with Fig. 11. If a link is established, the DOSP requests the recipient to indicate acceptance of the network phone call by, for example, pressing the "\*" button on the handset in step 530. Steps 530 through 566 is essentially the same as that of the first and second modes of operation shown in

15          Fig. 5a from steps 110 through 144.

          A benefit of the fourth mode of operation is that initial long distance toll calls over the public switched telephone network for establishing an network connection between the caller and the recipient are completely eliminated. Another benefit of the fourth mode is that it does not involve modification to network service providers but rather uses less expensive (compared to

20          network service providers) dedicated dial-out service providers to allow the outgoing telephone calls to be made to the recipient. However, the delay in making a connection may be twice as long in comparison to the first mode.

          The fifth mode of operation will now be described with reference to Fig. 7. If continuous network access such as cable Internet access is used by the caller, a continuous

25          network link is provided so that there will not be a need to dial into the service provider nor conduct authentication. If the recipient has such continuous Internet access, the caller automatically dials the recipient via packet-switched means without the need for conducting a short long-distance call as associated with the first mode of operation; the caller could have accessed the Internet via any means. This is similar to the third mode of operation described

30          above using POTS Internet access however, using a continuous Internet access such as cable does not require any modifications to the cable service provider. This operation mode is also much faster for connection than the first, second, or third mode of operation.

telephone call, to establish a point-to-point protocol link in step 230. During this process, the caller may be informed of the call status with phone ringing sounds on the recipient's telephone. This process is described in more detail below in connection with Fig. 11. If a link is established, the recipient's DCF sends a packet with a recipient's appliance IP address to the caller's appliance in step 232. The caller's appliance then connects to the recipient's appliance via a TCP/IP connection in step 236. Also, if the recipient is using the telephone line for Internet access and the recipient's computer system has a software that is compatible with the appliance running, a connection also may be attempted. If a connection is not achieved as determine in step 238, a retry operation may be performed in steps 240 and 236. Otherwise, the caller may be informed that no connection is established in step 242 and the appliance hangs up in step 244. For example, if the recipient is using a telephone line and receives a busy signal or is already on the phone with an Internet call in progress, the recipient's DCF sends a packet to the caller's appliance of the busy signal. If a TCP/IP connection is made, the two parties may begin talking as indicated in step 246. When the call is terminated, the TCP/IP connection is terminated in step 248 and the parties may hang up as indicated at 244.

A benefit of the third mode of operation is that initial long distance toll calls over the public switched telephone network for establishing an network connection between the caller and the recipient are completely eliminated. The delay in making a connection may be reduced in comparison to the first mode as well. This third mode does involve modification to network service providers to allow the outgoing telephone calls to be made.

The fourth mode of operation is similar to the third mode by using dial-out service providers (DOSP) that could be located at many locations world-wide where there are large concentrations of appliance users rather than depending on network service providers to provide dial-out service. These dial-out service providers would be connected to the Internet and have dial-out capability using modem banks to inform the recipient's appliance of an incoming Internet call. This operation eliminates the need to modify existing network service providers for dial-out capability. Figure 6b shows the operation and will be described.

Steps 500 through 514 is the same as the third mode of operation described previously. If a PPP/SLIP link is established in step 510, the caller's appliance sends a packet with the recipient's access information to the local central database (step 516) and queries the central database for the IP address of the recipient's dial-out service provider in step 518. This step is described in more detail below in connection with Fig. 12. If the IP address of the recipient's

An example of using the appliance with a continuous cable television Internet access will be described. The appliance may be equipped with a network interface module comprising an Ethernet interface card connected to a cable modem such as those manufactured by Motorola. The appliance may be connected to both the cable Internet access line and the local exchange carrier. The unique MAC address that comes with each Ethernet interface card is registered with the cable Internet access provider for authentication. If static IP address is not assigned, the cable Internet access provider will automatically assign a dynamic IP address to the user whenever a connection is established using the Ethernet interface card's unique MAC address. If dynamic IP addressing is used, the appliance updates the central database upon obtaining a new IP address.

Fig. 7 shows an example of a task flow for establishing a connection using a continuous Internet link. Caller dials the recipient's number (step 450) and the appliance determines if the call is a long-distance call in step 452. If it is not a long-distance call, a local POTS call may be made. Otherwise, the caller's appliance may check the phonebook (step 455) as an option and if the recipient's telephone number is found, it sends a packet with the recipient's phone number to the central database (CDB) in step 456. Regardless of whether the phonebook function is used or not used, a CDB query is made (step 458) with the recipient's phone number and if the recipient's IP address is found (step 460) the caller's appliance attempts to establish a connection with the recipient's appliance in step 470. If the recipient's IP address is not found, then the caller is notified to decide on making a conventional toll call in step 462. After a conventional toll call is made in step 464, the caller then hangs up (step 466). If a conventional call is not made, the caller simply hangs up (step 468). If the recipient's IP address is found, the caller's appliance attempts to connect in step 472. If a connection is not made, the caller's appliance attempts to retry in step 474. If after several retries the connection could not be established, the caller is informed (step 480) and the caller hangs up in step 482. If a connection is made, the call is initiated in step 476 via TCP. Upon call completion, the TCP connection is closed with the recipient's appliance (step 478) and the call is terminated in step 482. The continuous connection to the network such as those with cable Internet access provider simplifies and speeds up the network call connection process.

Fig. 8 describes in more detail how a caller's appliance or compatible system checks and updates the phonebook of a recipient such as performed in step 101 of Fig. 5a and step 205 of Fig. 6a. The process of looking up a phone book eliminates the requirement of establishing a

long-distance call and incurring toll charges to determine if a recipient is capable of receiving a network call via the Internet and also provides the caller an option to cancel the call without establishing a toll connection with the recipient. If the recipient's phone number is found in its internal phonebook, the processes in Fig. 5 or Fig. 6 continue. However, if the recipient's phone number is not found, the caller is informed of this status (step 404) and requests the caller to decide if the appliance or compatible system should check if the recipient is a subscriber (step 406). If the caller decides not to conduct the check, the caller is given the option to continue with a PSTN toll call (step 408). If the caller decides not to continue with a toll call, the appliance hangs-up (step 414). Otherwise, a conventional long-distance call is made (step 410) and upon call completion, the appliance hangs-up. If the caller decides to check if a recipient is a subscriber, the caller's appliance dials into the local network service provider to establish a PPP/SLIP link (step 416). Upon establishing the PPP/SLIP link, the caller's appliance queries a central database server with the recipient's telephone number to check the status of the recipient's subscriber status (step 418). If the recipient is determined to be not a subscriber, i.e., not in the database at the decision step 420, then the procedure for a request to continue with a PSTN toll call (steps 408-414) is carried out. Otherwise, the central database sends a confirmation packet to the caller's appliance with the telephone number and any other pertinent information (step 422). The caller's appliance automatically updates the phonebook with the recipient's information (step 424) and the caller is informed of the update (step 426). Upon completion the subsequent steps are then continued. The appliance's user interface will allow any telephone number in the phonebook to be added, deleted, or edited.

How the appliance dials into a network service provider or dedicated communication facility to establish PPP/SLIP link will now be described in more detail in connection with Fig. 9. This example assumes that the network service providers are accessed using a regular telephone line (i.e. POTS). It is possible to make such a connection via a cable television modern or by connection through electrical power lines, among other mechanisms. In this embodiment, the appliance makes a regular telephone call to a network service provider to make a connection as indicated at step 250. If a connection is not made, as determined in step 252, the appliance may retry this operation as indicated at 254 and 250. Otherwise, the caller may be informed that connection was not made in step 256 and the appliance hangs up in step 258. If a connection to the network service provider is made, authentication information is sent to the provider in step 260. If authentication is not achieved, as determined in step 262, a retry of the

authentication operation may be performed as indicated at 264 and 260. Otherwise, the caller may be informed that authentication was not achieved in step 266 and the appliance hangs up in step 268. If authentication is achieved, a PPP/SLIP link may be established in step 270.

Successful establishment of this link, as determined in step 272 results in the appliance being  
5 successfully connected to the network. Otherwise, a retry operation may need to be performed in step 274 and 250.

Referring now to Fig. 10, the process of updating the central database with a network address will now be described in more detail. Each appliance has a CDB network address already encoded. If the appliance happens to have a CDB network address not in its locale,  
10 during initial setup when the user inputs the telephone number and other calling codes, the remote CDB automatically assigns an network address of a CDB in the appliance's locale and updates the appliance with the new CDB network address. Using a local CDB should help decrease connection time for calling. It also may help increase the connection speed for someone who wants to call the appliance because the recipient's local CDB may be directly contacted  
15 rather than by multicasting or broadcasting.

The CDB updating process involves sending information which comprise of the current network address and any other correlating unique information such as a telephone number for updating to the central database server in step 280. This information is sent in a packet, of which example formats will be described in more detail below in connection with Figs. 13 and 14. The  
20 appliance then awaits for a reply from the central database in step 282. If a reply does not indicate that data has been successfully updated, as determined in step 284, an attempt to update the information is retried in step 280. It may be desirable to put a time out operation in this loop, as indicated at 283. If a time out occurs, the caller is informed and may hang up as indicated at 285.

Referring now to Fig. 12, the logic flow of the central database will now be described in more detail. In particular, the central database server receives a request in step 290 that indicates the recipient's telephone number or other means for access that provides a unique identification of how the recipient connects to the network. This may be, for example, a telephone number. The database is then searched by the server for the recipient's unique identification information in  
25 step 292. If it is not found, a "not found" packet is then sent in step 294. If the information is found, the recipient's data, such as the network address of the dedicated communication facility used by the recipient and its personal network address and any other pertinent information, are  
30

packaged in a packet which is then sent to the caller's appliance in step 298.

The CDB request may be substituted by broadcasting and multicasting for any mode of operation. In such an embodiment, the caller's appliance processes the information packet and broadcast/multicast it to the world-wide Internet or other "white-page" services such as the "People Find" service from Lycos, or the "Big Yellow" Internet business yellow pages to obtain the recipient's individual information. The CDB or the recipient's DCF answers with at least the DCF network address when a matching recipient is found. After establishing contact with the CDB or recipient's DCF, the caller's appliance has the option to store and maintain the recipient's information in a local cache, i.e., phonebook for future use to minimize continual connections with CDB in an effort to reduce delays in establishing contact with the recipient for subsequent phone calls. If the recipient's or recipient's DCF network address is unavailable, the caller's appliance is informed and may be provided with an option to make a conventional long-distance phone call or automatically switch to the first mode of operation if the recipient was determined to be a subscriber as described above.

Example packet types which may be used by the system are shown in Figs. 13 and 14. These packets are transmission control protocol (TCP) packets that communicate over dedicated ports. The TCP packet shown in Fig. 13 includes a first byte of data indicating a type which may include a central database query, phone query, dedicated communication facility update, phone update, additions and deletions, or message indicating the party is ready to talk. The next four bytes of data indicate a length which represents the length of the data field 304 which follows. The data portion of the packet may contain one or more type, length and value entities, such as shown in Fig. 14. The type field 306 indicates a type such as whether the data includes a phone number. The length field 308 indicates the length of the value field 310. By using such packets, each of the central database, dedicated communication facility and the appliance readily may identify information which it needs to process, and how that information should be processed.

How a recipient's dedicated communication facility dials a recipient's appliance to establish a PPP/SLIP link, such as performed in step 230 of Fig. 6, will now be described in more detail in connection with Fig. 11. This operation is performed in manner similar to how a computer generally contacts a network server provider via a modem. In particular, the dedicated communication facility dials out to the recipient via the plain old telephone system (POTS) or other access media used by the appliance, in step 320. After step 320, if the caller hangs up

during the outgoing call step 328, the caller's appliance will inform the recipient's DCF to cancel the call before disconnecting from TCP/IP connection in step 330. In step 322, upon being informed of the caller appliance's on-hook status, the recipient's DCF cancels the outgoing call to the recipient. If the call is answered in step 322, authentication is performed in step 323. If authentication is not achieved, the appliance hangs up in step 328. If authentication is achieved, then an IP address is set in 324 and a PPP/SLIP link is established in 326. If the call is not answered, the dedicated communication facility hangs up in step 328 and informs the caller.

A user interface also may be provided for call status notification and setting up the appliance for initial and continual use. The user may be presented with menu items or call status such as by visual means with a liquid crystal display, audible means with voice messages to the speaker, or a combination thereof. The user may interact with the appliance via one or more means such as with a numeric keypad found on a conventional phone attached to the appliance, pushbuttons, dials, or by voice commands to the handset that may be recognized by the appliance.

A set of main menu items for the appliance may include (a) phonebook, (b) Internet access setup, (c) dialing setup, and (d) auto upgrade. When the phone book menu item is selected, phone numbers may be displayed and scrolled using an electro-mechanical thumb-dial interface attached to a potentiometer. Push buttons for deleting and editing a telephone number may be provided. New telephone numbers might be added, edited, or deleted manually using the numeric dialing keypad on the conventional telephone connected to the appliance. The Internet access setup if using POTS might include an Internet service provider's telephone number, username, and password. ASCII or foreign characters may be entered into the appliance by, for example, using the same thumb-nail dial described previously to select a character, the numeric dialing keypad on the conventional telephone attached to the appliance, or a dedicated keypad. The dialing setup might include the user's telephone number with area code and country code, call waiting cancel, and other dial-out prefixes. The auto upgrade menu item, which may be used with Flash ROM for field upgradability, may be executed with a single command from the user. Upon receiving the user command, the appliance automatically upgrades the appliance's software by auto-dialing into the network service provider, establishing a networking link such as PPP and TCP/IP, contacting a pre-programmed network address supporting a software download, uploading to the network address the model and version of the appliance, receiving the updated software or patches, hanging up, and executing the downloaded software in the

appliance.

By using the mechanisms described above, a caller's appliance ensures that a connection is made between the packet-switched network and the recipient of a telephone call. At least three modes of operation may be used in order to ensure that this connection is made. Additionally, with these appliances the network service providers of the caller and recipient do not require dedicated ports for voice communication. Accordingly, the cost of long distance calls may be reduced without substantially increasing the cost of maintenance of specialized voice communication hardware on the part of the network access providers. By providing a dedicated appliance such telephony is not limited to computer users and owners. With these features this telephony appliance may be used in the same manner as a conventional telephone.

Having now described a few embodiments of the invention, it should be apparent to those skilled in the art that the foregoing is merely illustrative and not limiting, having been presented by way of example and practice. Numerous modifications and other embodiments are within the scope of one of ordinary skill in the art.

For example, other communication protocols over a packet-switched network may be used such as TCP/IP, Frame Relay, ISDN, and IPX providing for reliable transmission or User Datagram Protocol (UDP) that uses Real-Time Protocol (RTP) to handle streaming audio and video and which is a part of the ITU H.323 standard for unreliable transmission. Wireless and asynchronous transfer mode (ATM) networks operating using packet or cell switching also may be used.

Additional functionality also may be provided, such as video and wireless capabilities. An example of video and wireless capability might include a mobile appliance that functions in a vehicle such as an automobile where the outgoing packet-switched communications signals such as video signals are sent by processing video images of the sender using a charge-coupled display (CCD) area sensors such as those sold by Sony Corporation and audio signals are sent by processing voice or audio from the sender using a microphone with active acoustical error cancellation circuitry for full-duplex hands-free speakerphone operation. The incoming packet-switched communication signals are also processed and delivered to the recipient via same wireless means. The incoming processed audio may be transmitted, for example, through the automobile's speakers via radio frequency (RF) signals sent directly to a radio's antenna inside the vehicle. The incoming processed video may be transmitted via a high-resolution liquid crystal display (LCD) such as those sold by Fujitsu or a miniature cathode ray tube (CRT) such



as those found on small television sets for which the image of the recipient can be seen directly from a visual display or viewed, for example, reflected off the front windshield of an automobile so that the driver quickly can focus in and out of the visual image while driving.

Flowing fax transmissions to conventional fax machines or storing fax transmissions also  
5 may be added by using standard fax and reliable network transmission protocols. Capability commonly found in conventional telephones also may be added, such as number memory, a mute button, a redial button, speed dial, alphanumeric keypad, answering service, caller identification, call-waiting option, calling capability without using telephone number, caller identification  
10 memory, teleconferencing, full duplex speaker phone, cordless handset, voice mail, etc. These functions may be integrated using telephony application programming interfaces (TAPI) developed by Microsoft and Intel for computer telephony application development such as those for PBX systems.

An appliance also may be constructed so as to accommodate different telephony  
standards such as telephone jacks and various POTS transmission laws such as A-law and Mu-  
15 law.

These and other modifications are contemplated as falling within the scope of the invention as defined by the appended claims and equivalents thereto.

CLAIMS

1. A communication system for communication using a packet switched network, comprising:  
a first network access system for providing access to the packet switched network;  
a second network access system for providing access to the packet switched network;  
5 a first appliance having means for connecting to the first network access system through a first access medium, and means for sending and receiving packets through the means for connecting to the packet switched network;  
a second user appliance having means for connecting to the second network access system through a second access medium, wherein the second appliance includes means for causing the first  
10 appliance to connect to the packet switched network through the first network access system using the means for connecting to the first network access system, and means for sending and receiving packets to and from the first appliance through the means for connecting and the packet switched network.
- 15 2. The communication system of claim 1, wherein the means for causing the first appliance to connect to the packet switched network in the second appliance comprises:  
means for connecting with the first appliance using a public switched telephone network; and  
means for instructing the first appliance to connect to the first network access system using the means for connecting of the first appliance.
- 20 3. The communication system of claim 1, wherein the means for causing the first appliance to connect to the packet switched network in the second appliance comprises:  
means for identifying the first network access system; and  
means for instructing the first network access system to connect with the first appliance  
25 through the means for connecting in the first appliance.
4. The communication system of claim 1, further comprising:  
a central database of user information including, for each of the first and second appliances,  
a first unique identifier indicating an address for the appliance accessible using the packet switched  
30 network and a second unique identifier indicating an access mechanism for establishing a connection over an access medium between the first and second network access systems and the first and second appliances, and comprising means, operative in response to a query, for returning one of the first and

second unique identifiers.

5. An appliance for communication using a packet switched network,  
means for connecting the appliance to a first access medium;  
5 means for connecting to a first network access system connected to the packet switched  
network using the access medium;  
means for causing another appliance to be connected through a second access medium to a  
second network access system connected to the packet switched network; and  
means for sending communication packets through the packet switched network to the other  
10 appliance after connection of the other appliance to the packet switched network is established.
6. A database system for storing information supporting a communication system using a  
packet switched network, wherein first and second appliances are connected through first and second  
access media to first and second network access systems which are connected to the packet switched  
15 network, comprising:  
means for storing user information including, for each of the first and second appliances, a  
first unique identifier indicating an address for the appliance accessible using the packet switched  
network and a second unique identifier indicating an access mechanism for establishing a connection  
over an access medium between the first and second network access systems and the first and second  
20 appliances; and  
means, operative in response to a query, for returning one of the first and second unique  
identifiers.
7. The database system of claim 6, further comprising means for adding user information to the  
25 database.
8. The database system of claim 6, further comprising means for deleting user information from  
the database.
- 30 9. The database system of claim 6, further comprising means for updating user information in  
the database.

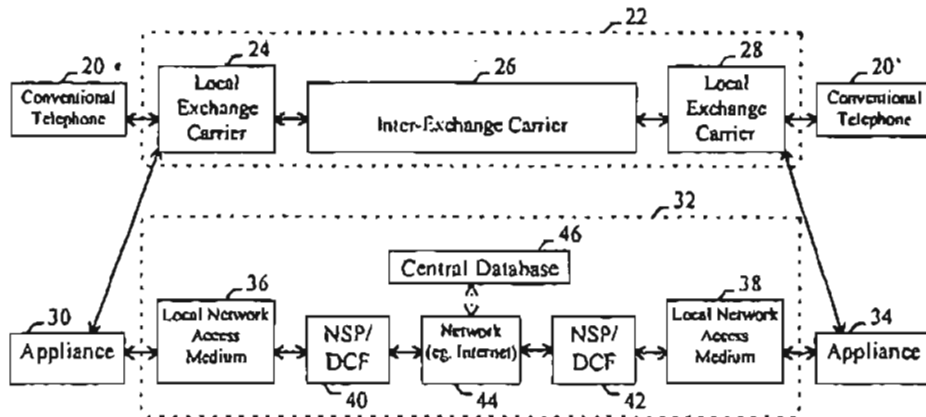

FIG. 1

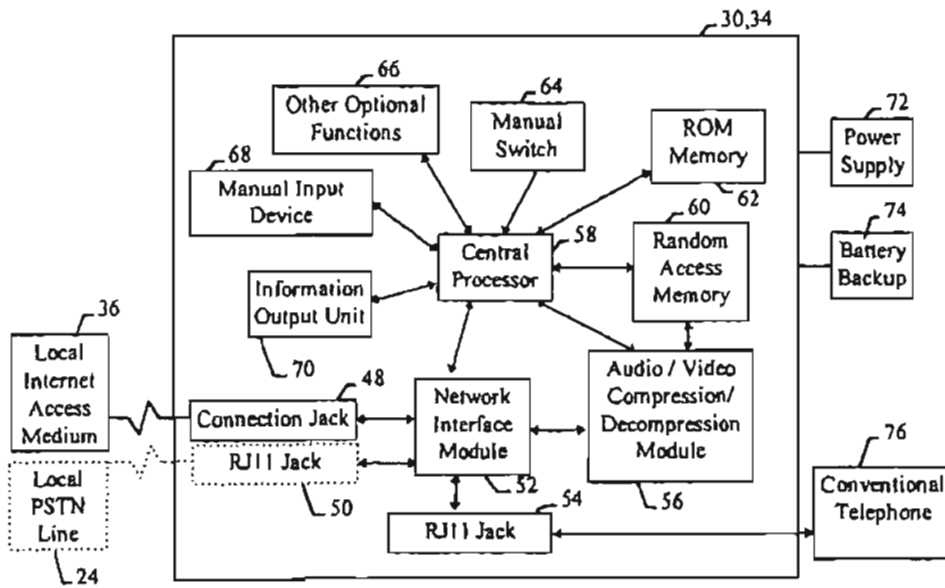

FIG. 2a

2/12

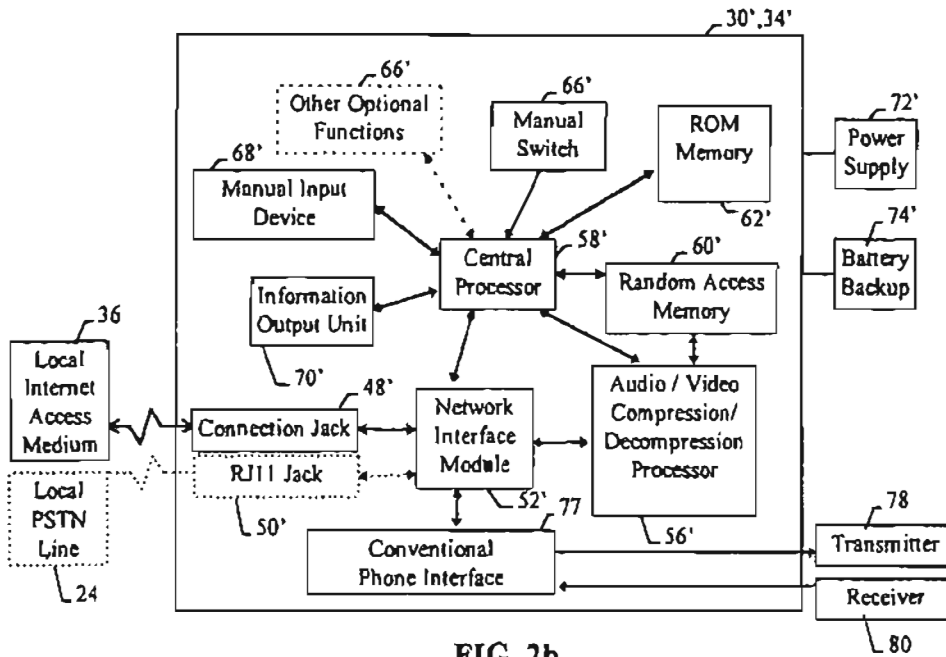

FIG. 2b

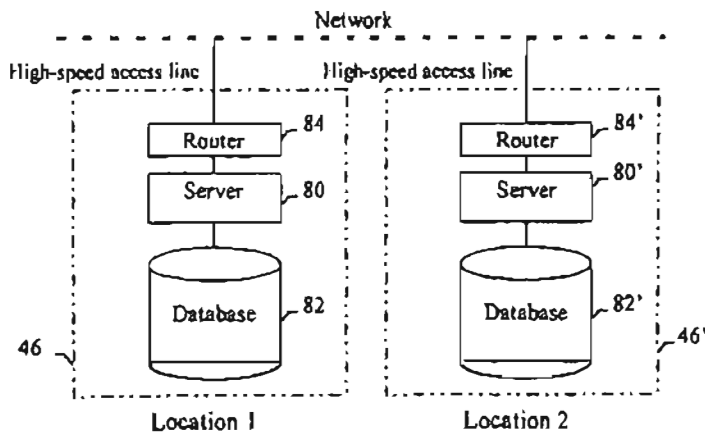

FIG. 3

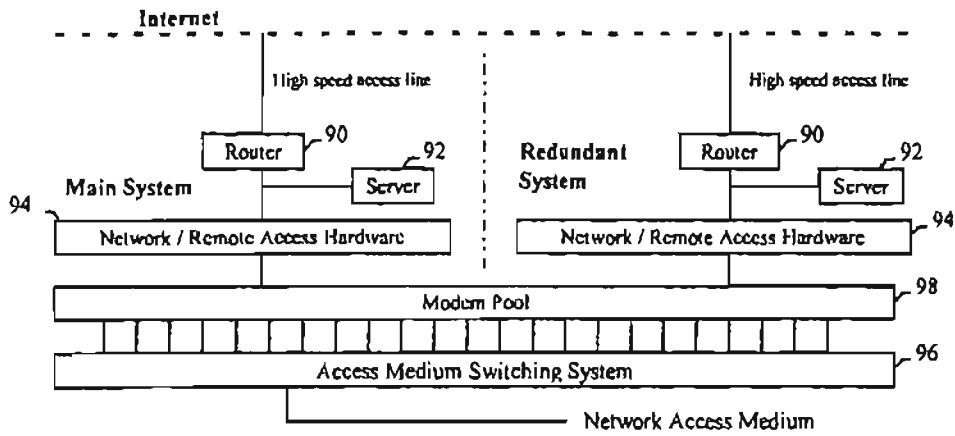

FIG. 4

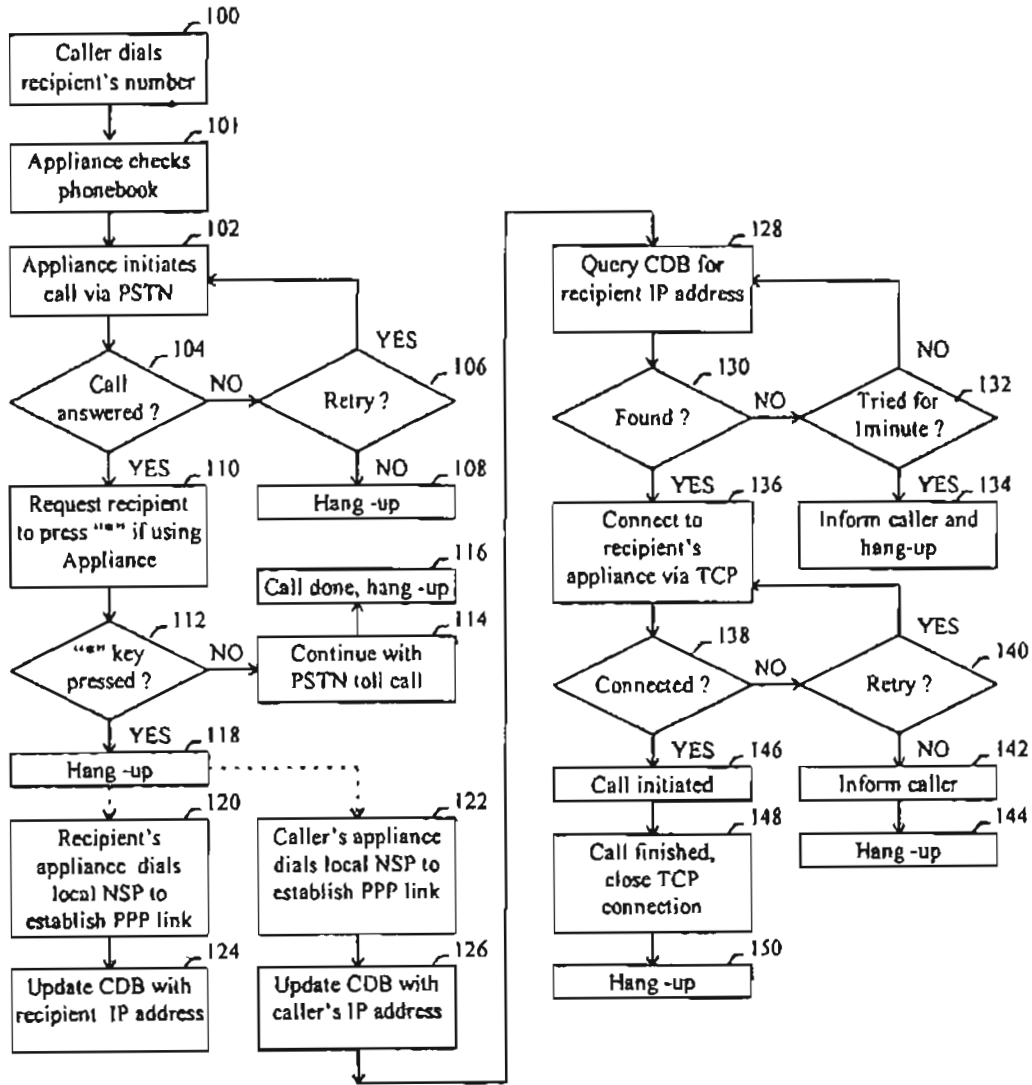

FIG. 5a

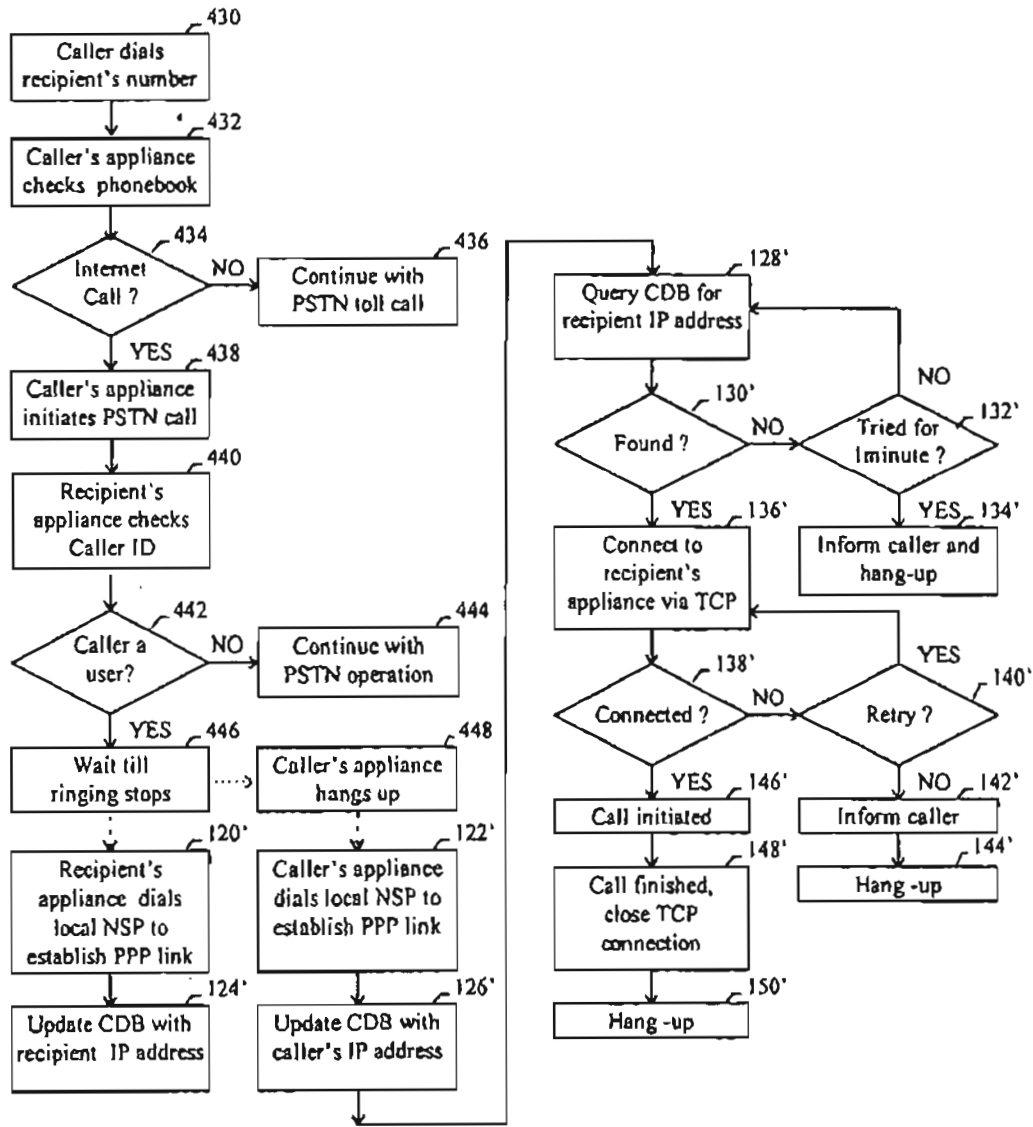

FIG. 5b



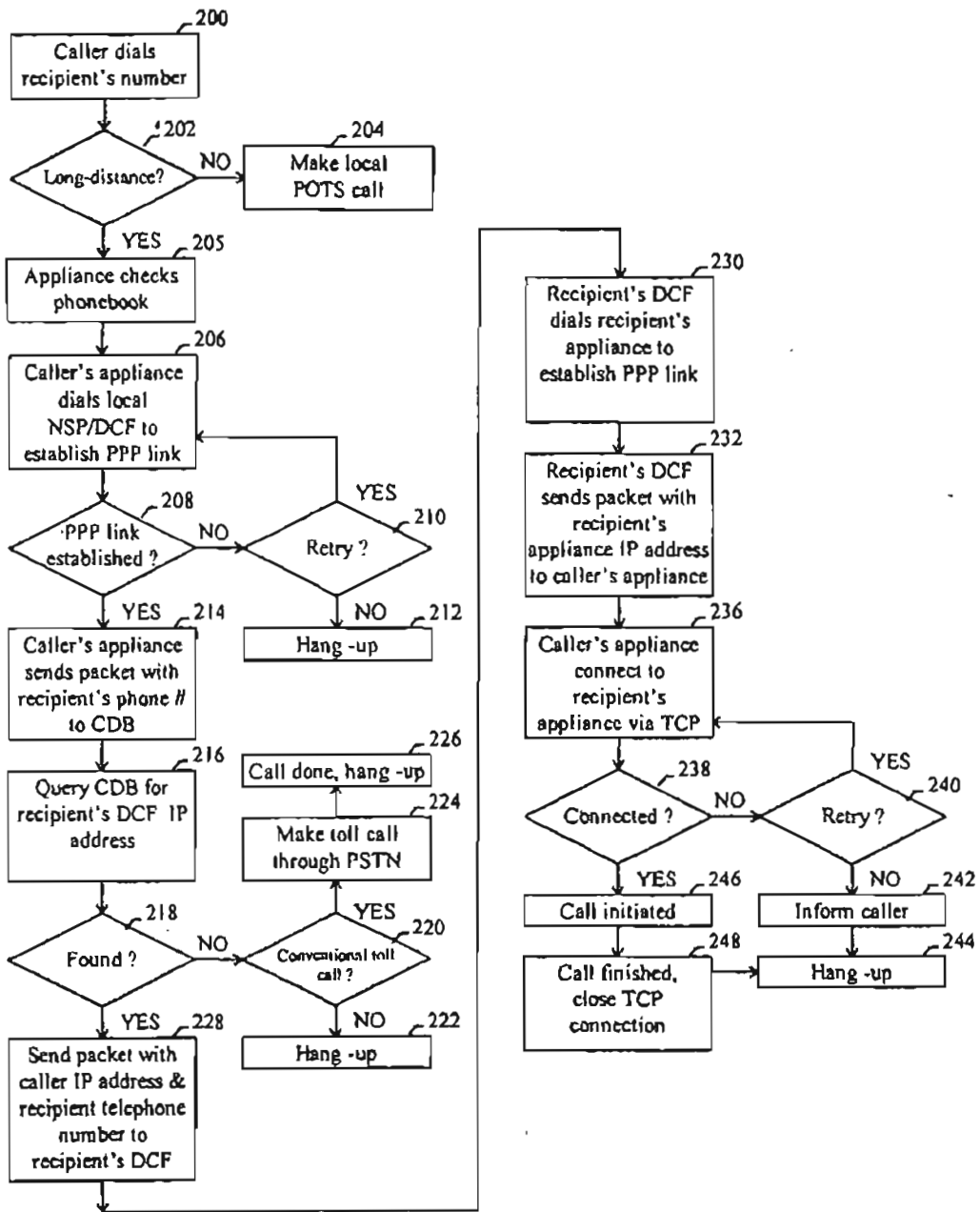

FIG. 6a

7/12

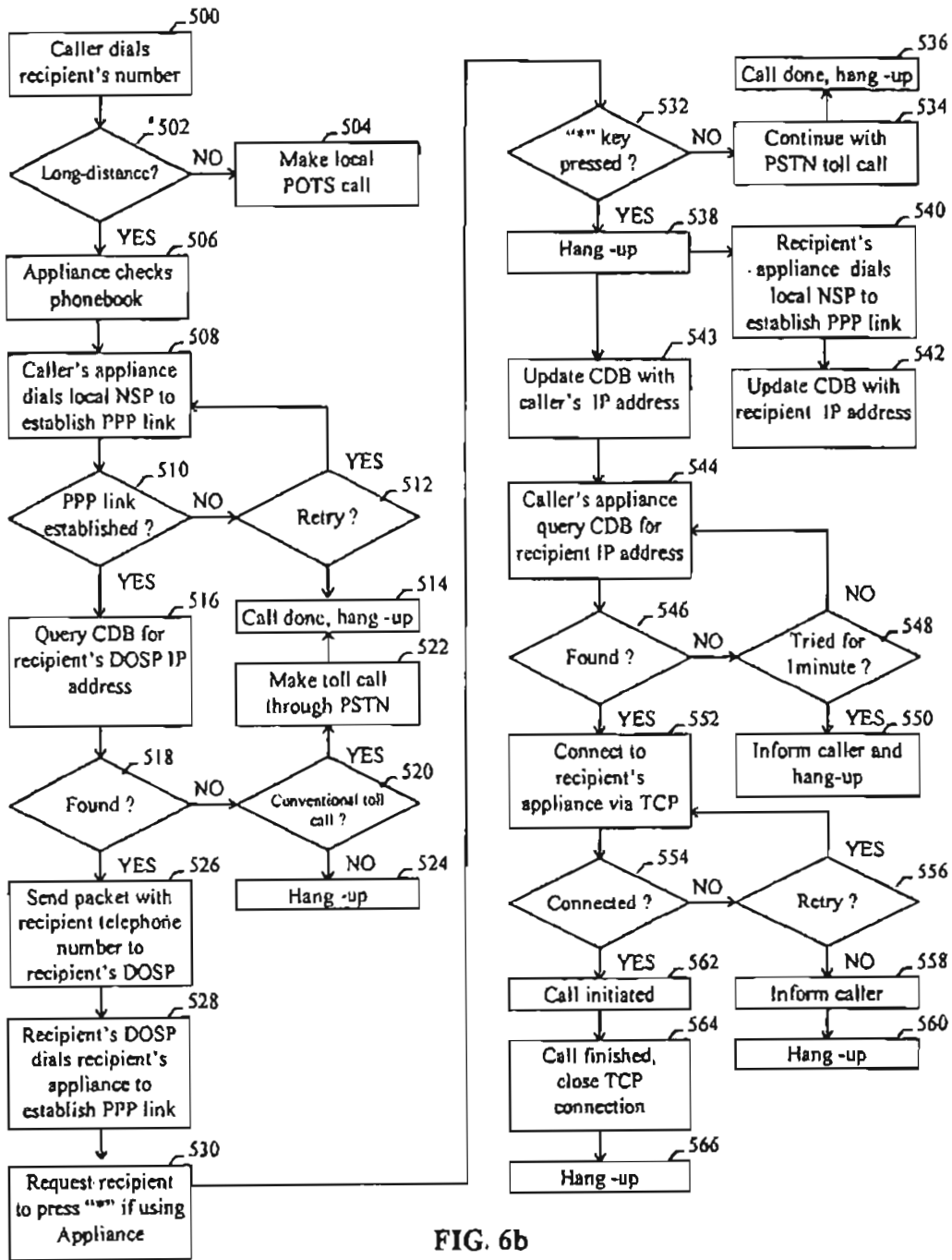

FIG. 6b

8/12

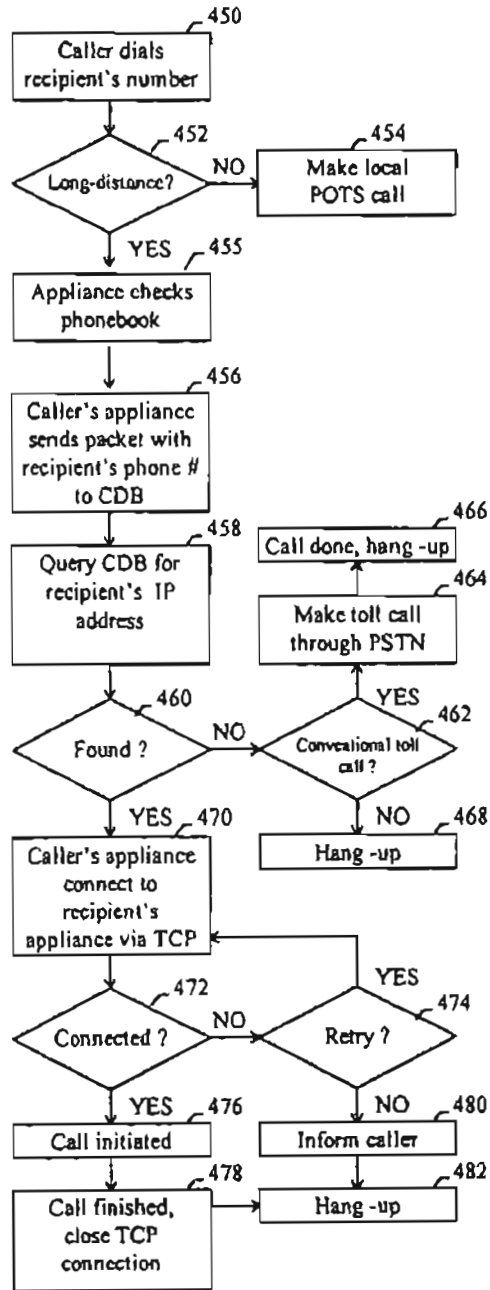

FIG. 7

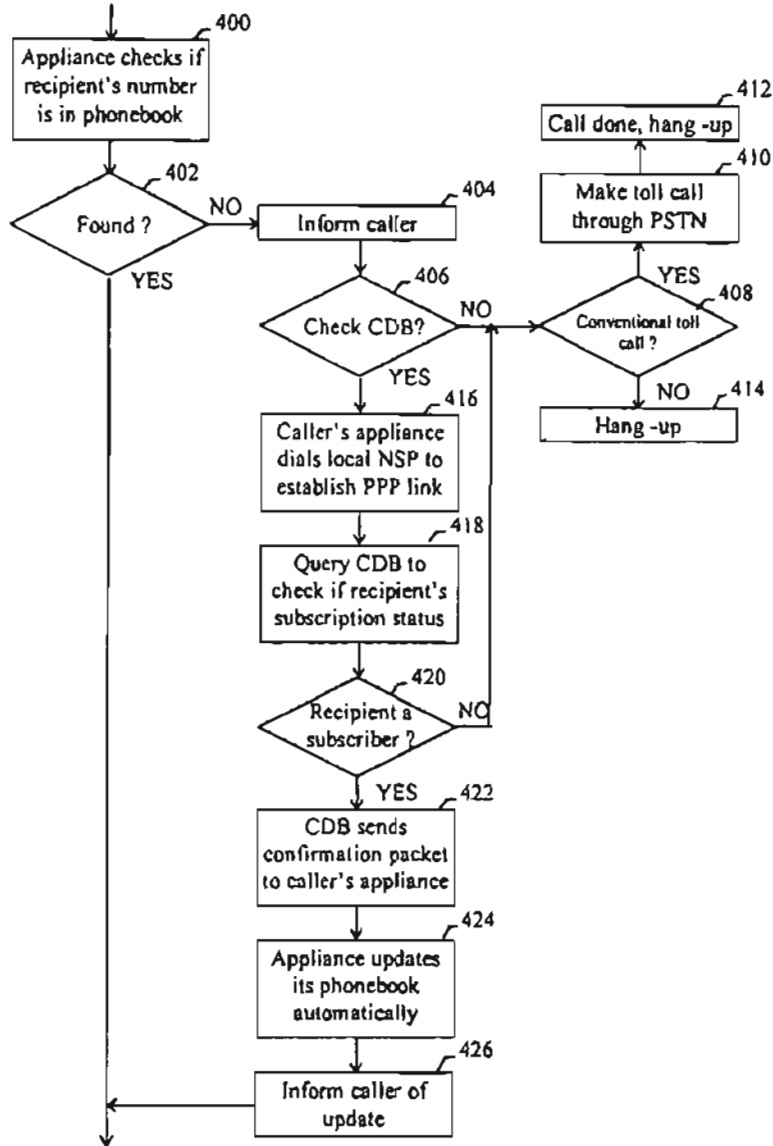

FIG. 8

10/12

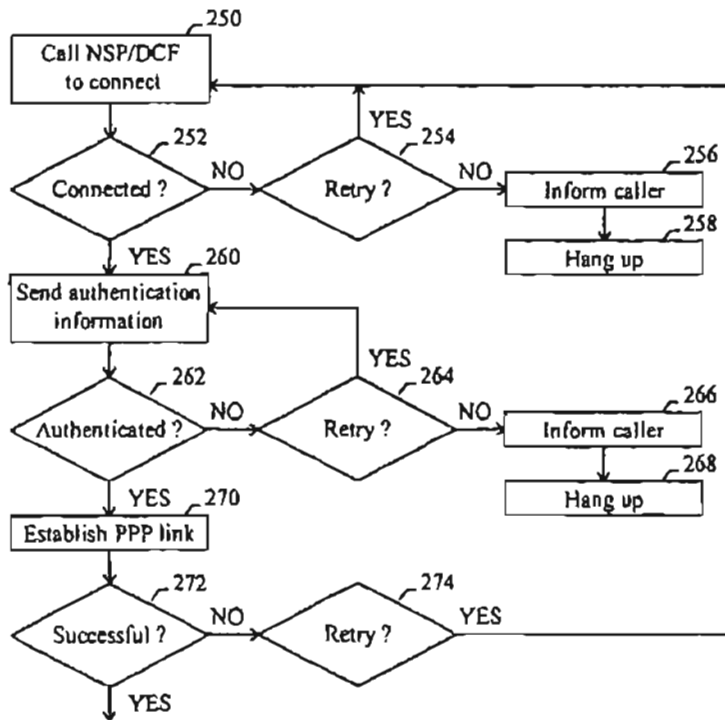

FIG. 9

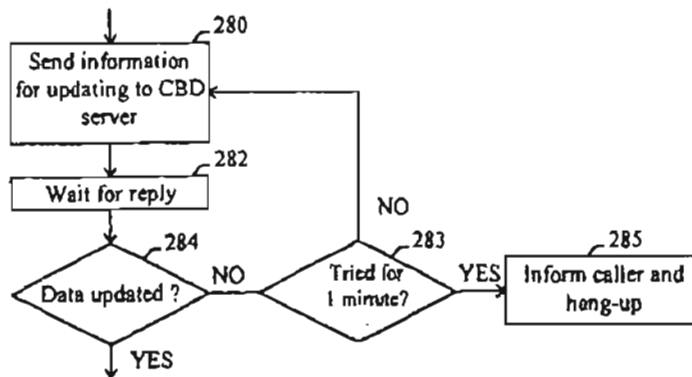

FIG. 10

11/12

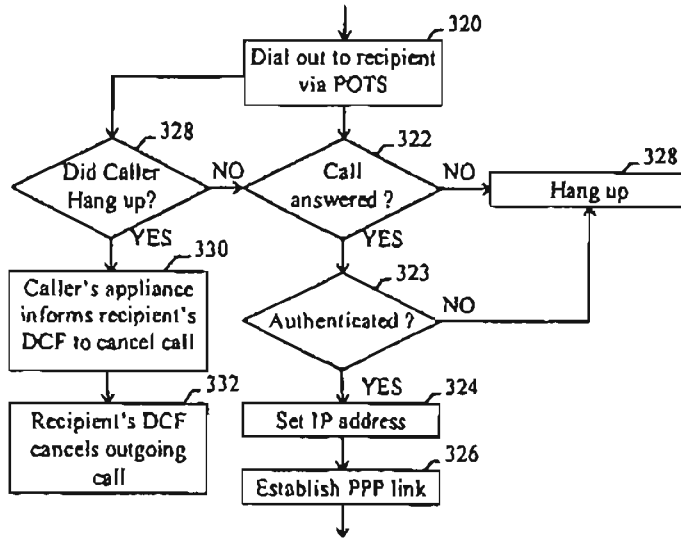

FIG. 11

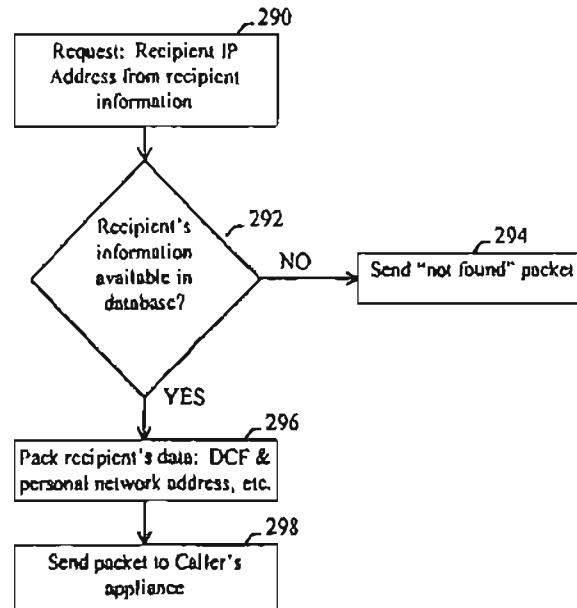

FIG. 12

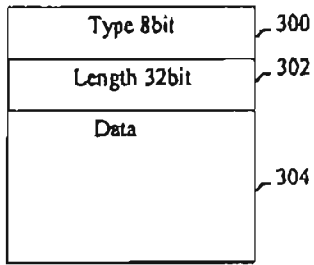

FIG. 13

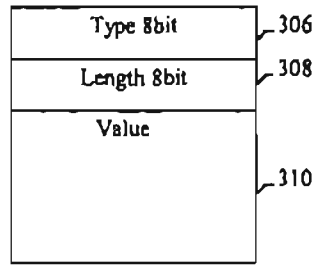

FIG. 14

## Electronic Acknowledgement Receipt

<b>EFS ID:</b>	6626285
<b>Application Number:</b>	90010416
<b>International Application Number:</b>	
<b>Confirmation Number:</b>	1061
<b>Title of Invention:</b>	Point-to-Point Internet Protocol
<b>First Named Inventor/Applicant Name:</b>	6108704
<b>Customer Number:</b>	42624
<b>Filer:</b>	Michael R. Casey
<b>Filer Authorized By:</b>	
<b>Attorney Docket Number:</b>	2655-0188
<b>Receipt Date:</b>	14-DEC-2009
<b>Filing Date:</b>	17-FEB-2009
<b>Time Stamp:</b>	11:37:54
<b>Application Type:</b>	Reexam (Third Party)

### Payment information:

Submitted with Payment	no
------------------------	----

### File Listing:

Document Number	Document Description	File Name	File Size(Bytes)/ Message Digest	Multi Part /.zip	Pages (if appl.)
1	NPL Documents	F0099_steve_oltmanns_voice_and_comm.pdf	391732 <small>e05641632275c8278bca8ad63a144a10f0d4d8d4</small>	no	6

### Warnings:



2	NPL Documents	F0100_stuart_cheshire_Internet_mobility.pdf	1104263 b67c0f0d22d61e1a7ccc95e7e9696c099634b4a1	no	12
<b>Warnings:</b>					
<b>Information:</b>					
3	NPL Documents	F0101_susan_angebrannt_integrating_audio.pdf	1090942 c89e79c6ba015c7db698853b501db619f0a7232	no	19
<b>Warnings:</b>					
<b>Information:</b>					
4	NPL Documents	F0102_t_kamae_visualTerminals.pdf	1251355 28397972aedc3a141e144c7ab154040e8ee36bed	no	22
<b>Warnings:</b>					
<b>Information:</b>					
5	NPL Documents	F0103_t_kamae_voiceData.pdf	584972 3d0b694d2ab6027a3d62fa97b31231ccf7545b34	no	9
<b>Warnings:</b>					
<b>Information:</b>					
6	NPL Documents	F0104_t7540_digital_codec.pdf	2473859 715431ab20d6feb3620ca90b50b937620204304	no	66
<b>Warnings:</b>					
<b>Information:</b>					
7	NPL Documents	F0105_takashi_yamada_new_technologies.pdf	218690 9633e561853595444d287cdd1d2677db5c8bd5b6	no	7
<b>Warnings:</b>					
<b>Information:</b>					
8	NPL Documents	F0106_talk_description.pdf	290918 dcf7e75689b55455926a136a53fafa11483aefb	no	2
<b>Warnings:</b>					
<b>Information:</b>					
9	NPL Documents	F0107_Nikkei_Communications_with_SOR.pdf	1297348 c4a382f4c31e75666d1280d416785c8b58d9071	no	7
<b>Warnings:</b>					
<b>Information:</b>					
10	NPL Documents	F0108_theodore_bially_voice_communication.pdf	1047412 2c36160bba3c6376e069ec3e6885a0bb52439c19	no	14
<b>Warnings:</b>					
<b>Information:</b>					

11	NPL Documents	F0109_tov_tsuda_approach_t o_multi-service.pdf	420528 e13729eeaf92c9ca69e3892bca4dd454dc 364a	no	7
<b>Warnings:</b>					
<b>Information:</b>					
12	NPL Documents	F0110_Translation_Kokai_H7-1 29488.pdf	1380439 93da8abe700310a96bc5f681c173d1d234e 7f94a	no	7
<b>Warnings:</b>					
<b>Information:</b>					
13	NPL Documents	F0111_90010421_20090814_O ffice_Action.pdf	12999628 d0da6e7900357cd059953740c3a3b1792ffa d1e6	no	89
<b>Warnings:</b>					
<b>Information:</b>					
14	NPL Documents	F0112_90010422_20090825_O ffice_Action.pdf	15356967 402adcf630e544c67c1219a6568f72b80aff d5b	no	103
<b>Warnings:</b>					
<b>Information:</b>					
15	NPL Documents	F0113_90010424_20090825_O ffice_Action.pdf	12997272 86911051265915b30d1121b6a8b6bde881a b7d1f	no	87
<b>Warnings:</b>					
<b>Information:</b>					
16	NPL Documents	F0114_v_jacobson_rfc1185.pdf	664872 0624db5bd5c7bd08fce1d2d3d94916429a b2c805	no	20
<b>Warnings:</b>					
<b>Information:</b>					
17	NPL Documents	F0115_v_jacobson_rfc1323.pdf	1169785 247de0bb795a6e552126558b785cd21a869 92559	no	35
<b>Warnings:</b>					
<b>Information:</b>					
18	NPL Documents	F0116_vinton_cerf_packet_sat ellite.pdf	185290 18850c4eb7091f475750bad637d51083fb7 f5fa	no	5
<b>Warnings:</b>					
<b>Information:</b>					
19	NPL Documents	F0117_vocaltec_internet_phon e.pdf	946693 89a0631dbb1477a904b2c38f3a041c91070 b944a	no	5
<b>Warnings:</b>					
<b>Information:</b>					

20	Foreign Reference	F0118_WO-94-22087.pdf	1152846 92391f87f9a32fdfe9fd61b1807309bb2244 edee	no	36
<b>Warnings:</b>					
<b>Information:</b>					
21	Foreign Reference	F0119_WO-97-14234.pdf	1135850 2e57db3d957190c4e5d1bbf6d9f9cd6a1fa 4ec01	no	32
<b>Warnings:</b>					
<b>Information:</b>					
22	Foreign Reference	F0120_WO-98-11704.pdf	1721918 d0b89d65d64480fa15abe7af93f510dedfd7 8777	no	42
<b>Warnings:</b>					
<b>Information:</b>					
23	NPL Documents	F0121_written_opinion_in_PCT US9615504.pdf	227005 8d4e06cf9e7b33fa0d2c65c78dc585b248e9 2e9f	no	7
<b>Warnings:</b>					
<b>Information:</b>					
24	Reexam Certificate of Service	20091214_COS_0188.pdf	57596 794e6ee4ed14c945ae9b28bd62c77b73cd ed528	no	1
<b>Warnings:</b>					
<b>Information:</b>					
<b>Total Files Size (in bytes):</b>				60168180	
<p>This Acknowledgement Receipt evidences receipt on the noted date by the USPTO of the indicated documents, characterized by the applicant, and including page counts, where applicable. It serves as evidence of receipt similar to a Post Card, as described in MPEP 503.</p> <p><b><u>New Applications Under 35 U.S.C. 111</u></b>  If a new application is being filed and the application includes the necessary components for a filing date (see 37 CFR 1.53(b)-(d) and MPEP 506), a Filing Receipt (37 CFR 1.54) will be issued in due course and the date shown on this Acknowledgement Receipt will establish the filing date of the application.</p> <p><b><u>National Stage of an International Application under 35 U.S.C. 371</u></b>  If a timely submission to enter the national stage of an international application is compliant with the conditions of 35 U.S.C. 371 and other applicable requirements a Form PCT/DO/EO/903 indicating acceptance of the application as a national stage submission under 35 U.S.C. 371 will be issued in addition to the Filing Receipt, in due course.</p> <p><b><u>New International Application Filed with the USPTO as a Receiving Office</u></b>  If a new international application is being filed and the international application includes the necessary components for an international filing date (see PCT Article 11 and MPEP 1810), a Notification of the International Application Number and of the International Filing Date (Form PCT/RO/105) will be issued in due course, subject to prescriptions concerning national security, and the date shown on this Acknowledgement Receipt will establish the international filing date of the application.</p>					

**INFORMATION DISCLOSURE  
STATEMENT BY APPLICANT**  
FORM PTO-1449 (modified)

Sheet 1 of 10

Reexam number	90/010,416
First Named Inventor	Hufton
Patent Under Re-Exam	6108704
Issue Date	2000/08/22
Group Art Unit	3992
Examiner Name	KOSOWSKI, ALEXANDER J
Attorney Docket No.	2655-0188
Confirmation No.	1061

**FOREIGN PATENT DOCUMENTS**

Examiner Initials*	Cite No.	Document No.	Publication Date	Name of Patentee or Applicant of Cited Document	Notes
	1-1	WO-9003074	03-22-1990	LE CLERCQ, Patrick	
	1-2				
	1-3				
	1-4				
	1-5				
	1-6				
	1-7				
	1-8				
	1-9				
	1-10				
	1-11				
	1-12				
	1-13				
	1-14				
	1-15				
	1-16				
	1-17				
	1-18				
	1-19				
	1-20				
	1-21				
	1-22				
	1-23				
	1-24				

Examiner Signature		Date Considered	
--------------------	--	-----------------	--

\*Examiner: Initial if reference was considered, whether or not citation is in conformance with MPEP 609. Draw a line through citation if not in conformance and not considered. Include a copy of this form with next communication to applicant. Notes: If identified, the following is provided: EA = English Abstract, T = Translation, PF = Patent Family.

<b>INFORMATION DISCLOSURE STATEMENT BY APPLICANT</b> FORM PTO-1449 (modified)	Reexam number	90/010,416
	First Named Inventor	Hutton
	Patent Under Re-Exam	6108704
	Issue Date	2000/08/22
	Group Art Unit	3992
	Examiner Name	KOSOWSKI, ALEXANDER J
	Attorney Docket No.	2655-0188
	Confirmation No.	1061
Sheet 2 of 10		

NON-PATENT REFERENCES			
Examiner Initials*	Cite No.	Non-patent Reference bibliographic information, where available	Notes
	2-1	About NetPhone (undated)	
	2-2	After Downsizing: Overcoming Client-Server Chaos (May 21, 1994)	
	2-3	Barrow Street Research report on New Paradigm Software Corp. (dated sep. 20, 1995)	
	2-4	Camelot 10-Q for quarter ending January 31, 1995	
	2-5	Camelot Corporation 10-K, 1994	
	2-6	Camelot Corps Shining Internet Dream Draws Skeptics (Aug. 95)	
	2-7	Completed Beta Tester Agreements (May 1995)	

Examiner Signature		Date Considered	
--------------------	--	-----------------	--

\*Examiner. Initial if reference was considered, whether or not citation is in conformance with MPEP 609. Draw a line through citation if not in conformance and not considered. Include a copy of this form with next communication to applicant. Notes: If identified, the following is provided: EA = English Abstract, T = Translation, PF = Patent Family.

<b>INFORMATION DISCLOSURE STATEMENT BY APPLICANT</b> FORM PTO-1449 (modified)	Reexam number	90/010,416
	First Named Inventor	Hutton
	Patent Under Re-Exam	6108704
	Issue Date	2000/08/22
	Group Art Unit	3992
	Examiner Name	KOSOWSKI, ALEXANDER J
	Attorney Docket No.	2655-0188
	Confirmation No.	1061
Sheet 3 of 10		

NON-PATENT REFERENCES			
Examiner Initials*	Cite No.	Non-patent Reference bibliographic information, where available	Notes
	3-1	Correspondence with MacZone (Aug.-Sept. 1995)	
	3-2	DigiPhone and Camelot Documents	
	3-3	DigiPhone Documents (including Q and A) (prior to Sept. 1995)	
	3-4	DigiPhone Documents (prior to Sept. 1995)	
	3-5	DigiPhone for Mac (1996)	
	3-6	Electric Magic and Jabra Correspondence relating to new products (prior to 9/1995)	
	3-7	Electric Magic and PSINet License Negotiation Documentation (prior to Sept. 1995)	

Examiner Signature		Date Considered	
--------------------	--	-----------------	--

\*Examiner: Initial if reference was considered, whether or not citation is in conformance with MPEP 609. Draw a line through citation if not in conformance and not considered. Include a copy of this form with next communication to applicant. Notes: If identified, the following is provided: EA = English Abstract, T = Translation, PF = Patent Family.

<b>INFORMATION DISCLOSURE STATEMENT BY APPLICANT</b> FORM PTO-1449 (modified)	Reexam number	90/010,416
	First Named Inventor	Hutton
	Patent Under Re-Exam	6108704
	Issue Date	2000/08/22
	Group Art Unit	3992
	Examiner Name	KOSOWSKI, ALEXANDER J
	Attorney Docket No.	2655-0188
	Confirmation No.	1061
Sheet 4 of 10		

NON-PATENT REFERENCES			
Examiner Initials*	Cite No.	Non-patent Reference bibliographic information, where available	Notes
	4-1	Electric Magic Beta Tester Agreement dated July 21, 1995 (SKYPE-N2P01609523)	
	4-2	Electric Magic Company Releases NetPhone 1.2 and NetPub Server (dated June 8, 1995)	
	4-3	Electric Magic Information (May 1995)	
	4-4	Electric Magic Notebooks (prior to Sept. 1995)	
	4-5	Electric Magic Notes (including references to 4/18/95) and patent pending	
	4-6	Electric Magic Notes (including references to DigiPhone) (prior to Sept. 1995)	
	4-7	Electric Magic Notes (undated)	

Examiner Signature		Date Considered	
--------------------	--	-----------------	--

\*Examiner: Initial if reference was considered, whether or not citation is in conformance with MPEP 609. Draw a line through citation if not in conformance and not considered. Include a copy of this form with next communication to applicant. Notes: If identified, the following is provided: EA = English Abstract, T = Translation, PF = Patent Family.

<b>INFORMATION DISCLOSURE STATEMENT BY APPLICANT</b> FORM PTO-1449 (modified)	Reexam number	90/010,416
	First Named Inventor	Hutton
	Patent Under Re-Exam	6108704
	Issue Date	2000/08/22
	Group Art Unit	3992
	Examiner Name	KOSOWSKI, ALEXANDER J
	Attorney Docket No.	2655-0188
	Confirmation No.	1061
Sheet 5 of 10		

NON-PATENT REFERENCES			
Examiner Initials*	Cite No.	Non-patent Reference bibliographic information, where available	Notes
	5-1	Electric Magic Press Release (dated Mar. 13, 1995)	
	5-2	ElectricMagic and WebKat Licensing Documents (Sept. 1995 and prior)	
	5-3	E-mail dated May 9, 1995 re NetPhone Development with Jabra R/D	
	5-4	Fax dated 5/31/95 to IVP including press releases	
	5-5	Google Groups comp.dcom.videoconf posting (dated Jul. 5, 1995)	
	5-6	intern.tex (dated Aug. 30, 1994)	
	5-7	Jabra - Corporate and Product Backgrounder (April 19, 1995)	

Examiner Signature		Date Considered	
--------------------	--	-----------------	--

\*Examiner: Initial if reference was considered, whether or not citation is in conformance with MPEP 609. Draw a line through citation if not in conformance and not considered. Include a copy of this form with next communication to applicant. Notes: If identified, the following is provided: EA = English Abstract, T = Translation, PF = Patent Family



<b>INFORMATION DISCLOSURE STATEMENT BY APPLICANT</b> FORM PTO-1449 (modified)  Sheet 6 of 10	Reexam number	90/010,416
	First Named Inventor	Hutton
	Patent Under Re-Exam	6108704
	Issue Date	2000/08/22
	Group Art Unit	3992
	Examiner Name	KOSOWSKI, ALEXANDER J
	Attorney Docket No.	2655-0188
	Confirmation No.	1061

NON-PATENT REFERENCES			
Examiner Initials*	Cite No.	Non-patent Reference bibliographic information, where available	Notes
	6-1	Jabra Ear Phone Common Questions and Answers	
	6-2	Jabra Ear phone PC, 1995	
	6-3	Jabra Streamline Ear Phone, 1993	
	6-4	Letter of Intent including target dates (dated 19 Sept 95) (7 pgs)	
	6-5	List of source modules in NetPhone (dated Oct. 10, 1995)	
	6-6	MagicPhone Distribution Agreement (Aug. 1995)	
	6-7	Maven README (including 1994 copyright notice)	

Examiner Signature		Date Considered	
--------------------	--	-----------------	--

\*Examiner. Initial if reference was considered, whether or not citation is in conformance with MPEP 609. Draw a line through citation if not in conformance and not considered. Include a copy of this form with next communication to applicant. Notes: If identified, the following is provided. EA = English Abstract, T = Translation, PF = Patent Family.

<b>INFORMATION DISCLOSURE STATEMENT BY APPLICANT</b> FORM PTO-1449 (modified)	Reexam number	90/010,416
	First Named Inventor	Hutton
	Patent Under Re-Exam	6108704
	Issue Date	2000/08/22
	Group Art Unit	3992
	Examiner Name	KOSOWSKI, ALEXANDER J
	Attorney Docket No.	2655-0188
	Confirmation No.	1061
Sheet 7 of 10		

NON-PATENT REFERENCES			
Examiner Initials*	Cite No.	Non-patent Reference bibliographic information, where available	Notes
	7-1	Net as Phone (Internet World July 1995)	
	7-2	NET phone ad (with Jabra fax line) (May 95)	
	7-3	NetPhone 1.1 User Manual (including date 95-01-09)	
	7-4	NetPhone Advertisement (Aug. 1995)	
	7-5	NetPhone Correspondence (Jun.-July 1995)	
	7-6	NetPhone Development Plan (SKYPE-N2P01610487)	
	7-7	NetPhone Development Plan with time charts (including reference to 5/9/1995)	

Examiner Signature		Date Considered	
--------------------	--	-----------------	--

\*Examiner: Initial if reference was considered, whether or not citation is in conformance with MPEP 609. Draw a line through citation if not in conformance and not considered. Include a copy of this form with next communication to applicant. Notes: If identified, the following is provided: EA = English Abstract, T = Translation, PF = Patent Family.

**INFORMATION DISCLOSURE  
STATEMENT BY APPLICANT**  
FORM PTO-1449 (modified)

Sheet 8 of 10

Reexam number	90/010,416
First Named Inventor	Hutton
Patent Under Re-Exam	6108704
Issue Date	2000/08/22
Group Art Unit	3992
Examiner Name	KOSOWSKI, ALEXANDER J
Attorney Docket No.	2655-0188
Confirmation No.	1061

**NON-PATENT REFERENCES**

Examiner Initials*	Cite No.	Non-patent Reference bibliographic information, where available	Notes
	8-1	NetPhone Digital User Manual (dated 95-02-26)	
	8-2	NetPhone gives your Mac voice over the Internet (Inside the Internet - June 1995)	
	8-3	Netphone invoices (including invoices prior to 9/1995)	
	8-4	NetPhone Make Free Calls over the Internet (undated)	
	8-5	NetPhone Screenshots (undated)	
	8-6	NetPhone Tasks and Plans (dated Jan.-Feb. 1995)	
	8-7	New Paradigm Software Agreement (dated Oct. 9, 1995) referencing existing software as of that date	

Examiner Signature		Date Considered	
--------------------	--	-----------------	--

\*Examiner: Initial if reference was considered, whether or not citation is in conformance with MPEP 609. Draw a line through citation if not in conformance and not considered. Include a copy of this form with next communication to applicant. Notes: If identified, the following is provided. EA = English Abstract, T = Translation, PF = Patent Family.

<b>INFORMATION DISCLOSURE STATEMENT BY APPLICANT</b> FORM PTO-1449 (modified)	Reexam number	90/010,416
	First Named Inventor	Hutton
	Patent Under Re-Exam	6108704
	Issue Date	2000/08/22
	Group Art Unit	3992
	Examiner Name	KOSOWSKI, ALEXANDER J
	Attorney Docket No.	2655-0188
	Confirmation No.	1061
Sheet 9 of 10		

NON-PATENT REFERENCES			
Examiner Initials*	Cite No.	Non-patent Reference bibliographic information, where available	Notes
	9-1	Open Systems Today, Feb. 20, 1995	
	9-2	Order for NetPhone version 1.2 labels (dated 6 June 95)	
	9-3	Phoneless Phoning April 2, 1995	
	9-4	PowWow Chunked Protocol Specification, Last edited 3/12/1999	
	9-5	PowWow Native Protocols, last updated Dec. 8, 1998	
	9-6	Roadmap for the Internet (March 1995)	
	9-7	SlipMagic Ad for MacZone (dated 9/28/1995) for selling product	

Examiner Signature		Date Considered	
--------------------	--	-----------------	--

\*Examiner: Initial if reference was considered, whether or not citation is in conformance with MPEP 609. Draw a line through citation if not in conformance and not considered. Include a copy of this form with next communication to applicant. Notes: If identified, the following is provided: EA = English Abstract, T = Translation, PF = Patent Family.

<b>INFORMATION DISCLOSURE STATEMENT BY APPLICANT</b> FORM PTO-1449 (modified)	Reexam number	90/010,416
	First Named Inventor	Hutton
	Patent Under Re-Exam	6108704
	Issue Date	2000/08/22
	Group Art Unit	3992
	Examiner Name	KOSOWSKI, ALEXANDER J
	Attorney Docket No.	2655-0188
	Confirmation No.	1061
Sheet 10 of 10		

NON-PATENT REFERENCES			
Examiner Initials*	Cite No.	Non-patent Reference bibliographic information, where available	Notes
	10-1	The Mac Zone (Catalog) dated 1995	
	10-2	Two-way voice calls over the Internet (11/21/94)	
	10-3	Ubique documents relating to Virtual Places Products (dated 1995 and March, 1995)	
	10-4	Ubique Ships Virtual Places Client and Server (dated March 20, 1995)	
	10-5	Ubique, Ltd. Fact Sheet (referencing NetPhone codecs and Vocaltec) (date unknown)	
	10-6	Undated Technical document	
	10-7	Welcome to NetPhone Demo (includes copyright date 1994)	

Examiner Signature		Date Considered	
--------------------	--	-----------------	--

\*Examiner: Initial if reference was considered, whether or not citation is in conformance with MPEP 609. Draw a line through citation if not in conformance and not considered. Include a copy of this form with next communication to applicant. Notes: If identified, the following is provided: EA = English Abstract, T = Translation, PF = Patent Family.



## DEMANDE INTERNATIONALE PUBLIÉE EN VERTU DU TRAITE DE COOPÉRATION EN MATIÈRE DE BREVETS (PCT)

(51) Classification internationale des brevets <sup>4</sup> : <b>H04L 11/20, H04M 11/08</b>	A1	(11) Numéro de publication internationale: <b>WO 90/03074</b> (43) Date de publication internationale: 22 mars 1990 (22.03.90)
<p>(21) Numéro de la demande internationale: PCT/EP88/00814</p> <p>(22) Date de dépôt international: 6 septembre 1988 (06.09.88)</p> <p>(71) Déposant (pour tous les Etats désignés sauf US): CAPRICOM S.A. [LU/LU]; 40, boulevard Joseph II, L-1840 Luxembourg (LU).</p> <p>(72) Inventeur; et</p> <p>(75) Inventeur/Déposant (US seulement): LE CLERCQ, Patrick [BE/BE]; 381, avenue de la Forêt-de-Soignes, B-1640 Rhode-Saint-Genèse (BE).</p> <p>(74) Mandataires: VANDERPERRE, Robert etc.; Bureau Vander Haeghen, 63, avenue de la Toison d'Or, B-1060 Bruxelles (BE).</p>	<p>(81) Etats désignés: AT (brevet européen), BE (brevet européen), CH (brevet européen), DE (brevet européen), FR (brevet européen), GB (brevet européen), IT (brevet européen), JP, LU (brevet européen), NL (brevet européen), SE (brevet européen), US.</p> <p>Publiée avec rapport de recherche internationale.</p>	
<p>(54) Title: SYSTEM FOR THE AUTOMATIC NOTIFICATION OF MESSAGE RECEPTION IN AN ELECTRONIC MESSAGING SYSTEM</p>		
<p>(54) Titre: SYSTEME D'AVERTISSEMENT AUTOMATIQUE DE LA RECEPTION DE MESSAGES DANS UN SYSTEME DE MESSAGERIE ELECTRONIQUE</p>		
<p>(57) Abstract</p> <p>A microprocessor (12) is connected to the electronic messaging system for receiving the information identifying the messages in stand-by. A random access memory (16) is organized so as to constitute a file (FIL) containing codes (<math>u_1, u_2 \dots u_n</math>) identifying the addressees of predetermined messages and information (<math>n_1, n_2 \dots n_n</math>) representing the telephone numbers of said addressees. A modem (17) connected to a telephone line (6) is organized for extracting from said file (FIL) the information relating to telephone numbers and for automatically dialling the telephone numbers of the addressees in order to transmit call signals to them over the telephone line. The microprocessor (12) is organized for reading the queue of messages received in the electronic messaging system, for detecting therein the presence of identification codes (<math>u_1, u_2 \dots u_n</math>) contained in the file (FIL), for extracting from the file the telephone number information corresponding with each identification code detected, and for instructing the modem (7) to automatically dial the corresponding telephone numbers in order to emit a call signal over the telephone line (6) for a predetermined time interval.</p>		
<p>(57) Abrégé</p> <p>Un microprocesseur (12) est relié au système de messagerie électronique pour recevoir les informations qui identifient les messages en attente et une mémoire vive (16) est organisée pour constituer un fichier (FIL) contenant des codes (<math>u_1, u_2 \dots u_n</math>) qui identifient des destinataires de messages prédéterminés et des informations (<math>n_1, n_2 \dots n_n</math>) représentant les numéros de téléphone de ces destinataires. Un modem (17) connecté à une ligne téléphonique (6) est organisé pour extraire les informations de numéros de téléphone dudit fichier (FIL) et composer automatiquement les numéros de téléphone des destinataires afin de leur transmettre des signaux d'appel sur la ligne téléphonique. Le microprocesseur (12) est organisé pour lire la file d'attente des messages reçus dans le système de messagerie électronique, pour y détecter la présence des codes d'identification (<math>u_1, u_2 \dots u_n</math>) résidant dans le fichier (FIL), pour extraire du fichier l'information de numéro de téléphone correspondant à chaque code d'identification détecté, et pour donner ordre au modem (17) de composer automatiquement les numéros d'appel correspondants afin de lancer un signal d'appel sur la ligne téléphonique (6) pendant un intervalle de temps prédéterminé.</p>		

*UNIQUEMENT A TITRE D'INFORMATION*

Codes utilisés pour identifier les Etats parties au PCT, sur les pages de couverture des brochures publiant des demandes internationales en vertu du PCT.

AT	Autriche	ES	Espagne	MG	Madagascar
AU	Australie	FI	Finlande	ML	Mali
BB	Barbade	FR	France	MR	Mauritanie
BE	Belgique	GA	Gabon	MW	Malawi
BF	Burkina Faso	GB	Royaume-Uni	NL	Pays-Bas
BG	Bulgarie	HU	Hongrie	NO	Norvège
BJ	Bénin	IT	Italie	RO	Roumanie
BR	Bresil	JP	Japon	SD	Soudan
CA	Canada	KP	République populaire démocratique de Corée	SE	Suède
CF	République Centrafricaine	KR	République de Corée	SN	Sénégal
CG	Congo	LI	Liechtenstein	SU	Union soviétique
CH	Suisse	LK	Sri Lanka	TD	Tchad
CM	Cameroon	LU	Luxembourg	TG	Togo
DE	Allemagne, République fédérale d'	MC	Monaco	US	Etats-Unis d'Amérique
DK	Danemark				

Systeme d'avertissement automatique de la reception  
de messages dans un systeme de messagerie electronique

DESCRIPTION

Description de l'art anterieur

Un systeme de messagerie electronique tel que le sys-  
teme DISOSS (Distributed Office Support System) de  
5 marque IBM assure l'archivage et la distribution  
automatiques de messages et de documents au sein d'une  
entreprise ou d'une organisation. Un tel systeme  
comprend un ordinateur central sur lequel tourne un  
logiciel de messagerie electronique, un controleur  
10 d'ecran connecte a l'ordinateur et plusieurs terminaux  
connectes au controleur d'ecran. L'arrivee de messages  
ou documents dans l'ordinateur central est signalee  
par l'apparition d'une information dans une liste de  
messages et documents recus (file d'attente). La file  
15 d'attente se trouve transmise en permanence vers les  
divers terminaux et sur l'ecran de ceux-ci, les usa-  
gers peuvent consulter la file d'attente et demander  
la reception d'un message ou consulter un document  
identifie. Un systeme de messagerie electronique de ce  
20 genre rend de grands services en ce sens qu'il permet  
notamment d'ameliorer l'efficacite du travail adminis-  
tratif, d'ameliorer la communication entre decideurs  
et de reduire l'espace necessaire pour les archives.  
Cependant, un tel systeme ne permet pas d'avertir les



destinataires de messages ou de documents de l'arrivée de ces messages et de ces documents. Il s'agit là d'un désavantage universellement reconnu. La présentation d'un message ou d'un document, en effet, nécessite la consultation régulière sinon permanente de la file d'attente des messages reçus, ce qui peut entraîner des délais dans la réception des messages ou la communication des documents et requiert une surveillance quasi-constante des utilisateurs.

10

#### Résumé de l'invention

15

L'invention a pour objet un système électronique automatique qui remédie au désavantage évoqué plus haut et assure que les destinataires de messages ou de documents soient avertis automatiquement de l'arrivée de ces messages ou documents. Les particularités caractéristiques du système selon l'invention sont définies dans les revendications ci-annexées.

20

25

Un microprocesseur est relié au système de messagerie électronique pour recevoir les informations qui identifient les messages en attente et une mémoire vive est organisée pour constituer un fichier contenant des codes qui identifient des destinataires de messages prédéterminés et des informations représentant les numéros de téléphone de ces destinataires. Un modem connecté à une ligne téléphonique est organisé pour extraire les informations de numéros de téléphone dudit fichier et composer automatiquement les numéros de téléphone des destinataires afin de leur transmettre des signaux d'appel sur la ligne téléphonique. Le microprocesseur est organisé pour lire la file d'attente des messages reçus dans le système de messa-

35

gerie électronique, pour y détecter la présence des codes d'identification résidant dans le fichier, pour extraire du fichier l'information de numéro de téléphone correspondant à chaque code d'identification détecté, et pour donner ordre au modem de composer automatiquement les numéros d'appel correspondants afin de lancer un signal d'appel sur la ligne téléphonique pendant un intervalle de temps prédéterminé.

5

10 Le système selon l'invention a pour avantages que les destinataires de messages ou de documents reçus sont avertis immédiatement par téléphone de la réception d'un message ou document qui leur est destiné et que les messages et documents peuvent être réceptionnés plus rapidement par leurs destinataires et cela sans nécessiter de surveillance particulière. De plus, les destinataires peuvent être prévenus non seulement localement par l'intermédiaire d'un réseau téléphonique intérieur mais également à longue distance par l'intermédiaire d'un réseau téléphonique extérieur. Ce système selon l'invention peut également remplacer avec avantage l'utilisation telex en cas d'urgence au sein d'un groupe utilisant un système de messagerie électronique. Enfin, le système selon l'invention est d'un faible coût en matériel et en logiciel.

15

20

25

#### Description des dessins

30 La Fig. 1 représente schématiquement un système de messagerie électronique auquel est intégré un système d'avertissement automatique selon l'invention.

La Fig. 2 représente schématiquement l'architecture générale du système d'avertissement automatique selon l'invention.

35

La Fig. 3 est un organigramme du processus d'avertissement téléphonique mis en oeuvre dans le système selon l'invention.

5

Description d'un mode de réalisation exemplaire

Dans la figure 1 est représenté schématiquement un système de messagerie électronique tel que le système DISOSS. Un système de ce genre comprend un processeur central ou processeur-hôte 1, un contrôleur d'écran 2 et un ensemble de terminaux dont un terminal 4 est représenté. Le processeur-hôte gère la réception et la distribution des messages et documents. La réception d'un message ou document est signalée par l'insertion d'une information dans une liste ou file d'attente (QUEUE). Cette liste d'attente peut être transmise sur la ligne 3 et visualisée sur l'écran de chaque terminal 4 à la demande de l'utilisateur. Un exemple de liste d'attente est reproduit au tableau 1 ci-après.

Tableau 1

25	1	2	3	4	5	6	7	8	9
	QUEUE	IDENTIF	TYPE			DATE	WT	DATE	WT
						(M/D)	(H:M)	(M/D)	(H:M)
30	BXLDIS32	BXLARSIN	RECP	4	0	08/03	332:19	08/03	332:19
	BXLDIS32	BXLPC2EX	RECP	2	0	08/05	284:13	08/05	284:13
	BXLDIS32	EPSPC1GS	RECP	1	0	08/16	24:46	08/16	24:46

Dans cet exemple, chaque rubrique de la liste d'attente contient la référence de la liste (colonne 1), le code d'identification d'un destinataire (colonne 2), le type de liste d'attente (colonne 3), le nombre de messages entrés pour le destinataire (colonne 4), le nombre de tentatives de réception des messages (colonne 5), la date et le temps d'attente du premier message entré (colonnes 6 et 7), la date et le temps d'attente du message le plus ancien (colonnes 8 et 9).  
Lorsqu'un message ou document a été réceptionné par son destinataire, la rubrique correspondante se trouve mise à jour ou effacée selon qu'il reste encore un message à réceptionner par le destinataire en question ou que le dernier message ou document en attente a été réceptionné. Dans ce système connu, chaque usager doit consulter la file d'attente et pour cela manipuler le clavier de son terminal pour savoir si un message ou document lui est destiné.

Suivant l'invention, le système décrit ci-dessus est avantageusement complété par un système d'avertissement automatique 10 destiné à avertir automatiquement le destinataire d'un message ou d'un document par téléphone sitôt qu'un tel message ou document est reçu. Le système d'avertissement automatique selon l'invention est connecté d'une part au contrôleur d'écran 2 au moyen d'un câble coaxial 5 et il est connecté d'autre part à une ligne téléphonique 6 qui peut être reliée à un central téléphonique privé ou à un réseau téléphonique public représenté par le bloc 7.

L'architecture générale du système d'avertissement automatique 10 est représentée schématiquement par blocs à la figure 2. Le câble coaxial 5 est connecté à un circuit de connexion 11 qui sert d'interface avec

le bus 20 reliant entre elles les différentes unités organiques du système. Ces unités sont essentiellement un microprocesseur 12, un écran de contrôle 13 avec son interface 14, une mémoire ROM de grande capacité  
5 15 pour stocker les programmes de commande, une mémoire vive 16 pour constituer un fichier comme on le verra plus loin, et un circuit modem 17 dont la fonction sera décrite ultérieurement.

10 Le microprocesseur 12 est un dispositif bien connu en soi, qui peut être réalisé dans divers modes d'exécution relevant de la compétence normale de l'homme de l'art pour exécuter différentes connexions et tâches fonctionnelles sous la direction de signaux de commande prévus dans un programme d'opération enregistré  
15 dans la mémoire morte 15. Celle-ci a par exemple une capacité d'au moins 10 MB (mégabytes ou méga-octets).

Suivant l'invention, on attribue un code particulier à  
20 chaque destinataire pour lequel un avertissement automatique est demandé et dans la mémoire vive 16 est constitué un fichier d'avertissement FIL. Les codes de destinataires sont appelés dans la suite codes  $u_1, u_2 \dots u_n$ . Dans le fichier FIL sont enregistrés les codes  
25  $u_1, u_2 \dots u_n$  identifiant les destinataires et pour chaque code, des données numériques  $n_1, n_2 \dots n_n$  représentant le numéro de téléphone du destinataire ainsi que des données  $t_1, t_2 \dots t_n$  représentant des paramètres de transmission pour chaque appel téléphonique ainsi qu'on le verra plus loin. Les numéros de  
30 téléphone peuvent être des numéros d'extension dans un réseau intérieur d'un groupe, des numéros d'appel d'une zone téléphonique locale ou des numéros d'appel interzonal ou à longue distance. Le modem 17 est un  
35 dispositif connu en soi, organisé pour composer auto-

matiquement des numéros de téléphone à partir de données numériques et produire des signaux propres à la transmission sur la ligne téléphonique 6.

5 Le système d'avertissement automatique selon l'invention fonctionne sous la direction du microprocesseur 12 animé ou organisé par un système de commande résidant dans la mémoire 15. Le fonctionnement du système selon l'invention est illustré par l'organigramme de  
10 la figure 3.

Après démarrage du système (étape 100), la première étape du fonctionnement (étape 101) consiste à établir la liaison avec le processeur-hôte 1 du système de  
15 messagerie électronique par l'intermédiaire du câble 3. Le microprocesseur 12 commande ensuite l'envoi au processeur-hôte 1 d'un signal de requête REQ demandant la présentation des codes d'identification des messages en attente (étape 102). En réponse au signal de  
20 requête REQ, le processeur-hôte 1 envoie les codes d'identification de destinataires figurant dans la liste d'attente QUEUE et le microprocesseur 12 en commande l'affichage sur l'écran de contrôle 14.

25 Le microprocesseur 12 commande alors la lecture du contenu du fichier FIL résidant dans la mémoire 16 et la comparaison de chaque code d'identification  $u_1, u_2 \dots u_n$  du fichier FIL avec les codes d'identification de la liste d'attente QUEUE (étape 103). Lorsque  
30 celle-ci contient un code correspondant à un des codes  $u_1, u_2 \dots u_n$  du fichier FIL, le microprocesseur 12 commande la production d'un signal d'adresse ADR pour adresser la mémoire 16 et extraire du fichier FIL les informations  $n_1$  représentant le numéro d'appel du  
35 destinataire identifié et les données paramétriques  $t_1$

précédemment mentionnées. Ces données servent à fixer les modalités ou conditions de transmission des signaux d'appel sur la ligne téléphonique 6. On peut par exemple fixer la durée de l'appel téléphonique, la tranche horaire durant laquelle l'appel doit être effectué, les jours pendant lesquels un appel peut être effectué, ou d'autres indications éventuelles. Le microprocesseur 12 commande l'affichage de ces informations sur l'écran de contrôle 14 en regard de chaque code d'identification. Sur l'écran de contrôle 14 apparaît par exemple une table du type montré au tableau 2 ci-après.

15 Tableau 2

$u_i$	N	DATE	$t_i$	$n_i$
BXLPC1DI	4	28/04	2:56	3280
BXLPC1RE	2	28/04	2:56	9145
EPSPC1OA	2	27/04	0:25	4302

Dans cette table exemplaire, chaque rubrique contient le code  $u_i$  d'un destinataire, le nombre N de messages ou documents reçus pour ce destinataire, la date de réception, la durée  $t_i$  (minutes et secondes) fixée pour chaque appel téléphonique, le numéro de téléphone  $n_i$  du destinataire. Les informations  $u_i$ ,  $t_i$  et  $n_i$ , ainsi qu'il a été dit plus haut, sont extraites du fichier FIL selon l'invention.

Le microprocesseur 12 commande ensuite le transfert des informations numériques  $n_1$ ,  $n_2$  ...  $n_n$  au modem 17 (étape 104) et le modem répond en composant automatiquement le numéro de téléphone et produisant les im-

pulsions propres à la transmission sur la ligne téléphonique 6 (étape 105), suivant un processus bien connu dans le domaine de l'art.

5       Après un laps de temps correspondant aux informations paramétriques  $t_i$  extraites du fichier FIL, le micro-  
processeur 12 envoie au modem 17 un ordre d'interrup-  
tion en réponse auquel le modem interrompt la trans-  
mission des impulsions sur la ligne téléphonique 6. Le  
10       même processus se déroule pour chacun des codes  
d'identification  $u_1, u_2 \dots u_n$  du fichier FIL. Lorsque  
tous les codes ont été scrutés (étape 106), le proces-  
sus de commande se poursuit (ligne 107) en répétant  
les opérations à partir de l'étape 102 et ce, jusqu'à  
15       ce qu'un ordre de fin soit reçu (étape 108). L'affi-  
chage sur l'écran de contrôle 14 est mis à jour auto-  
matiquement à intervalles réguliers ajustables.

20       Grâce au système selon l'invention, les destinataires  
de messages ou documents reçus dans un système de mes-  
sagerie électronique se trouvent avertis immédiatement  
par téléphone de la réception des messages et docu-  
ments qui leur sont destinés. Ces messages et docu-  
ments peuvent ainsi être réceptionnés très rapidement  
25       par leurs destinataires, ce qui accroît avec avantage  
et optimise l'efficacité du système de messagerie  
électronique. Il est à remarquer que les destinataires  
de messages et documents peuvent être prévenus aussi  
bien localement par l'intermédiaire d'un réseau télé-  
30       phonique intérieur que par communication téléphonique  
à longue distance.

35       Dans un mode de réalisation exemplaire, le système  
d'avertissement électronique 10 est constitué à partir  
d'un appareil disponible sur le marché sous l'appella-



tion d'ordinateur personnel, par exemple un appareil  
PC 3270 de marque IBM. Pour pouvoir communiquer, selon  
l'invention, avec le contrôleur d'écran 2 du système  
de messagerie électronique, l'ordinateur personnel  
5 doit être équipé d'une carte de connexion coaxiale,  
par exemple la carte d'interface 3270 Adapter de mar-  
que IBM. De plus, pour pouvoir convertir les données  
numériques extraites de la mémoire 16 en signaux pro-  
pres à être transmis sur la ligne téléphonique 6,  
10 l'ordinateur personnel doit être équipé d'une carte  
modem, par exemple une carte modem de la firme  
Devlonics Terminals N.V. compatible avec les protoco-  
les de transmission Hayes et CCITT V25bis bien connus  
de l'homme de l'art.

15

La mémoire vive de l'ordinateur personnel est utilisée  
pour contenir le fichier FIL précité et la mémoire  
morte de l'appareil est utilisée pour mémoriser le  
système de commande destiné à diriger le processus  
20 d'avertissement téléphonique automatique décrit dans  
ce qui précède. Il suffit de recopier sur disque dur,  
par exemple, le système de commande d'application en-  
registré préalablement sur une disquette.

25

Dans ce mode d'exécution exemplaire, dans lequel il  
est fait usage d'un ordinateur personnel pour réaliser  
le système selon l'invention, le système d'avertisse-  
ment entre en liaison opérationnelle avec l'équipe-  
ment de l'ordinateur personnel par l'intermédiaire de  
30 logiciels d'interfaçage, par exemple : le logiciel  
d'interfaçage DOS 3.30 pour la gestion d'un fichier et  
le logiciel API pour l'interfaçage avec le logiciel  
d'application (processus d'avertissement téléphonique)  
dans le cas d'un ordinateur personnel PC 3270. La  
35 liaison entre celui-ci et le système de messagerie

électronique peut s'effectuer au moyen d'un logiciel  
d'opération Workstation Program 1.00. Tous ces logi-  
ciels d'interfaçage, ainsi qu'il est clair pour l'hom-  
me de l'art, sont démarrés avant le démarrage du  
5 processus d'avertissement téléphonique selon l'inven-  
tion.

L'homme de l'art reconnaîtra que l'invention n'est  
nullement limitée au mode d'exécution exemplaire  
10 décrit à titre illustratif. Toute variante, modifica-  
tion ou tout agencement équivalent doit être consi-  
déré comme compris dans le cadre de l'invention.

## REVENDICATIONS

1. Système d'avertissement automatique de la réception d'un message dans un système de messagerie électronique, comprenant un microprocesseur (12) relié pour recevoir du système de messagerie électronique, les informations identifiant les messages en attente, une mémoire vive (16) organisée pour constituer un fichier (FIL) contenant les codes d'identification ( $u_1, u_2 \dots u_n$ ) de destinataires de messages prédéterminés et leurs numéros d'appel téléphonique ( $n_1, n_2 \dots n_n$ ), et un circuit modem (17) connecté à une ligne téléphonique (6), ce circuit modem étant agencé et organisé pour convertir les informations d'appel numériques ( $n_1, n_2 \dots n_n$ ) résidant dans ledit fichier (FIL) en signaux analogiques propres à la transmission sur la ligne téléphonique (6), le microprocesseur (12) étant organisé pour lire la file d'attente des messages (Queue) dans le système de messagerie électronique, pour y détecter la présence de codes d'identification ( $u_1, u_2 \dots u_n$ ), pour extraire du fichier (FIL) l'information d'appel numérique correspondant à chaque code d'identification ( $u_1, u_2 \dots u_n$ ) détecté, et pour donner ordre au circuit modem (17) de composer automatiquement les numéros d'appel correspondants pour leur transmission sur la ligne téléphonique (6).

2. Système selon la revendication 1, caractérisé en ce que le fichier (FIL) constitué dans la mémoire vive (16) contient en outre pour chaque numéro d'appel enregistré, des données fixant la durée de transmission de chaque appel téléphonique et/ou d'autres données de transmission.

3. Système selon la revendication 1 ou 2, caractérisé en ce qu'il est organisé pour afficher les données résidant dans le fichier (FIL) sur un écran de contrôle.
- 5 4. Système selon l'une quelconque des revendications précédentes, caractérisé en ce que la ligne téléphonique (6) est connectée à un central téléphonique privé.
- 10 5. Système selon l'une quelconque des revendications précédentes, caractérisé en ce que la ligne téléphonique (6) est connectée à un central téléphonique public.
- 15 6. Système selon l'une quelconque des revendications précédentes, caractérisé en ce qu'il est réalisé à partir d'un ordinateur personnel équipé d'une carte de connexion pour la connexion avec la ligne (5) allant vers le contrôleur d'écran (2), et d'une carte modem (17) pour la connexion avec la ligne téléphonique (6),
- 20 la mémoire vive de l'ordinateur personnel étant utilisée pour contenir le fichier (FIL) précité et la mémoire morte étant utilisée pour mémoriser le système de commande d'avertissement automatique.

1/2

FIG. 1

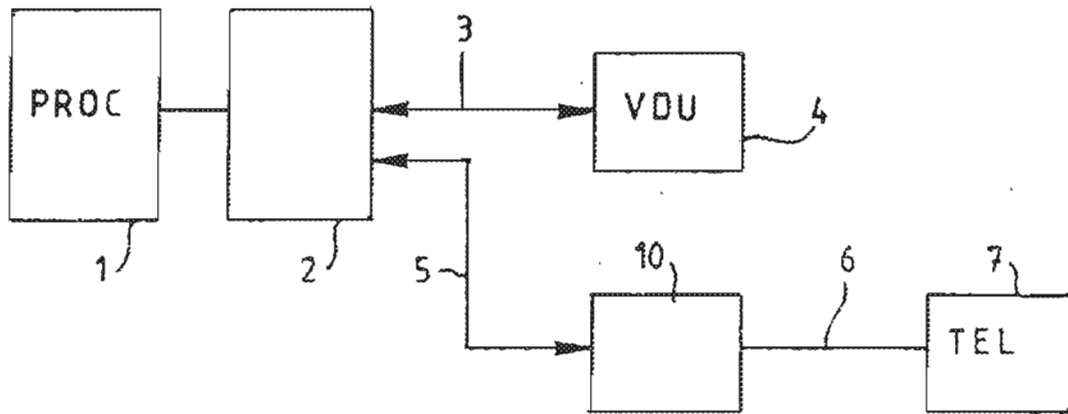

FIG. 2

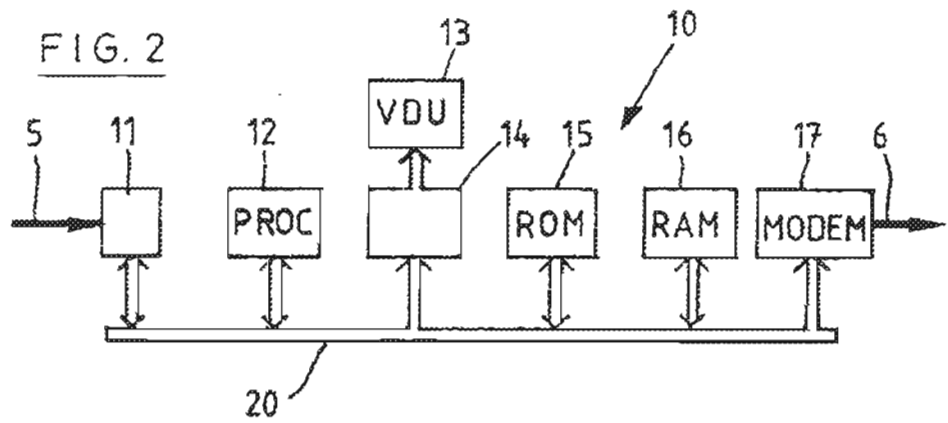
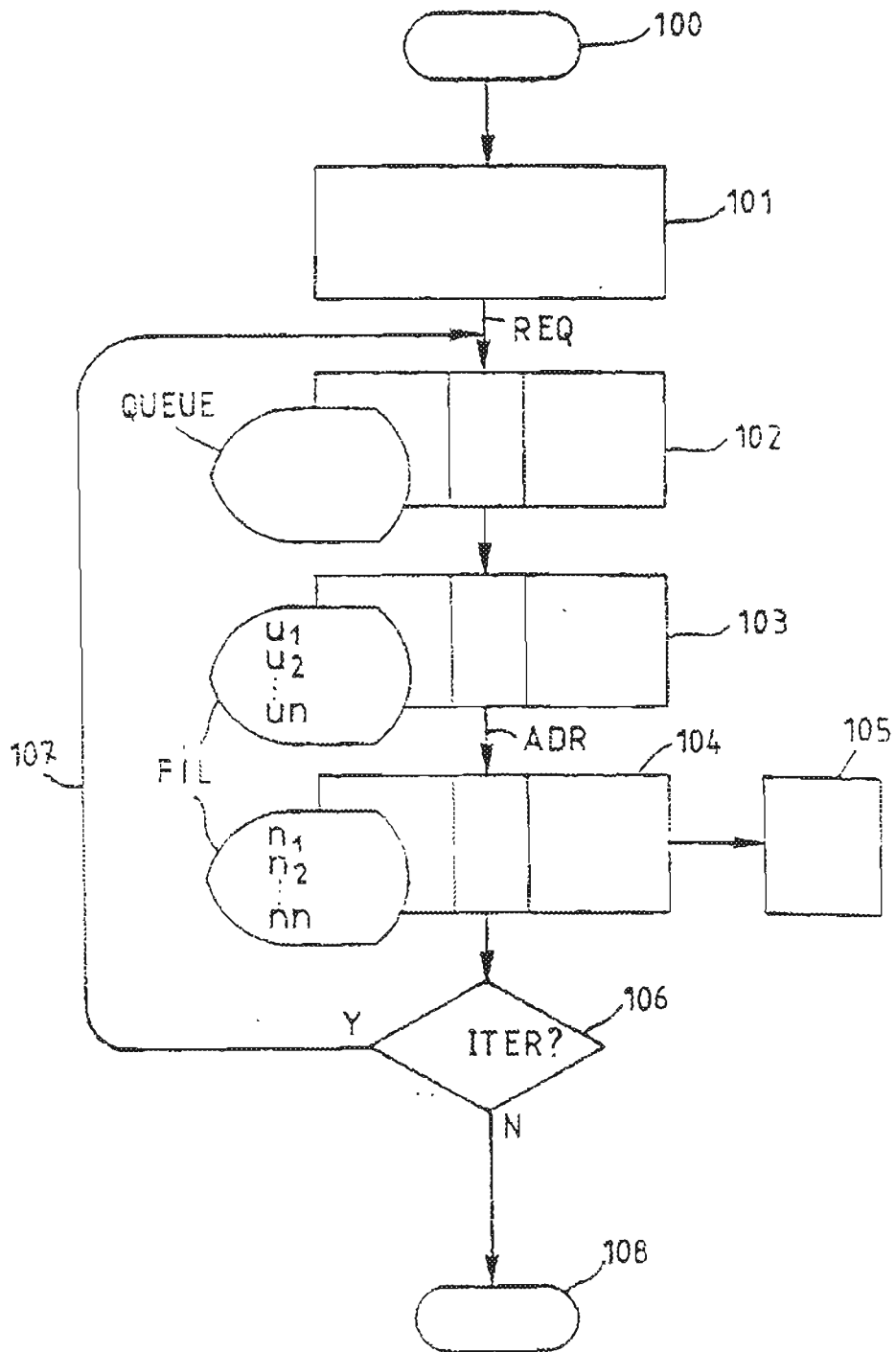

FIG. 3



# INTERNATIONAL SEARCH REPORT

International Application No PCT/EP88/00814

I. CLASSIFICATION OF SUBJECT MATTER (in several classification symbols apply, indicate all) <sup>1</sup>		
According to International Patent Classification (IPC) or to both National Classification and IPC		
Int.Cl.4	H04L 11/20 ; H04M 11/08	
II. FIELDS SEARCHED		
Minimum Documentation Searched <sup>1</sup>		
Classification System:	Classification Symbols	
Int.Cl.4	H04L ; H04M	
Documentation Searched other than Minimum Documentation to the Extent that such Documents are Included in the Fields Searched <sup>4</sup>		
III. DOCUMENTS CONSIDERED TO BE RELEVANT <sup>3</sup>		
Category <sup>5</sup>	Citation of Document, <sup>11</sup> with indication, where appropriate, of the relevant passages <sup>12</sup>	Relevant to Claim No. <sup>13</sup>
Y	US, A, 4506111 (TAKENOUCI) 19 March 1985 see column 1, lines 30-45; column 2, lines 47-51; column 4, lines 61-65; column 5, lines 9-17, column 5, line 64- column 6, line 8; column 8, lines 23-28; column 9, lines 4-12; column 10, lines 31-36; column 12, lines 42-45; figures 1, 5A	1
A	---	2, 3, 5
Y	IBM Technical Disclosure Bulletin, Vol. 27, Nr. 11, April 1985, (New York, US), "Beeper-electronic mail and reminder paging system" , page 6367 see the whole document	1
X	EP, A, 0087849 (VMX INC) 7 September 1983 see page 7, lines 13-28; page 9, lines 5-19 ; page 45, lines 19-33; page 54, lines 16-35; page 66, lines 27-31	1-3
.../...		
<div style="display: flex; justify-content: space-between;"> <div style="width: 45%;"> <p><sup>14</sup> Special categories of cited documents: <sup>15</sup></p> <p>"A" document defining the general state of the art which is not considered to be of particular relevance</p> <p>"E" earlier document but published on or after the international filing date</p> <p>"L" document which may throw doubts on priority claim(s) or which is cited to establish the publication date of another citation or other special reason (as specified)</p> <p>"O" document referring to an oral disclosure, use, exhibition or other means</p> <p>"P" document published prior to the international filing date but later than the priority date claimed</p> </div> <div style="width: 45%;"> <p>"I" later document published after the international filing date or priority date and not in conflict with the application but cited to understand the principle of theory underlying the invention</p> <p>"X" document of particular relevance: the claimed invention cannot be considered novel or cannot be considered to involve an inventive step</p> <p>"Y" document of particular relevance: the claimed invention cannot be considered to involve an inventive step when the document is combined with one or more other such documents, such combination being obvious to a person skilled in the art</p> <p>"S" document member of the same patent family</p> </div> </div>		
IV. CERTIFICATION		
Date of the Actual Completion of the International Search	Date of Mailing of this International Search Report	
2 May 1989 (02.05.89)	5 June 1989 (05.06.89)	
International Searching Authority: European Patent Office	Signature of Authorized Officer	

Form PCT/ISA/210 (second sheet) (January 1985)

III. DOCUMENTS CONSIDERED TO BE RELEVANT (CONTINUED FROM THE SECOND SHEET)		
Category*	Citation of Document, with indication, where appropriate, of the relevant passages	Relevant to Claim No
A		4-6
A	<p style="text-align: center;">---</p> Patent Abstracts of Japan, Vol. 9, Nr. 325 (E-368) (2048), 20 December 1985, & JP, A, 60157363 (FUJITSU K.K.) 17 August 1985 see the whole document	1
A	<p style="text-align: center;">---</p> Patent Abstracts of Japan, Vol. 4, Nr 181 (E-37) (663), 13 December 1980; & JP, A, 55123268 (FUJITSU K.K.) 22 September 1980 see the whole document	1-4
	-----	



ANNEX TO THE INTERNATIONAL SEARCH REPORT  
ON INTERNATIONAL PATENT APPLICATION NO.

EP 8800814

SA 24136

This annex lists the patent family members relating to the patent documents cited in the above-mentioned international search report. The members are as contained in the European Patent Office EDP file on 26/05/89. The European Patent Office is in no way liable for these particulars which are merely given for the purpose of information.

Patent document cited in search report	Publication date	Patent family member(s)	Publication date
US-A- 4506111	19-03-85	JP-A- 58040965	10-03-83
EP-A- 0087849	07-09-83	US-A- 4371752	01-02-83
		CA-A- 1157551	22-11-83
		EP-A, B 0029938	10-06-81
		US-A- 4581486	08-04-86
		US-A- 4602129	22-07-86
		US-A- 4640991	03-02-87
		US-A- 4585906	29-04-86
		US-A- 4580012	01-04-86
		US-A- 4652700	24-03-87

EP 1 183 100 2/82

For more details about this annex : see Official Journal of the European Patent Office, No. 12/82

# RAPPORT DE RECHERCHE INTERNATIONALE

Demande internationale N°

PCT/EP 88/00814

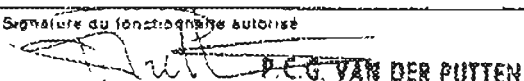
<b>I. CLASSEMENT DE L'INVENTION</b> (si plusieurs symboles de classification sont applicables, les indiquer tous) <sup>7</sup>		
Selon la classification internationale des brevets (CIB) ou à la fois selon la classification nationale et la CIB		
CIB <sup>4</sup> :        H 04 L 11/20; H 04 M 11/08		
<b>II. DOMAINES SUR LESQUELS LA RECHERCHE A PORTÉ</b>		
Documentation minimale consultée <sup>8</sup>		
Système de classification	Symboles de classification	
CIB <sup>4</sup>	H 04 L; H 04 M	
Documentation consultée outre que la documentation minimale dans la mesure où de tels documents font partie des domaines sur lesquels la recherche a porté <sup>9</sup>		
<b>III. DOCUMENTS CONSIDÉRÉS COMME PERTINENTS</b> <sup>10</sup>		
Catégorie <sup>*</sup>	Identification des documents cités, <sup>11</sup> avec indication, si nécessaire, des passages pertinents <sup>12</sup>	N° des revendications visées <sup>13</sup>
Y	US, A, 4506111 (TAKENOUCHI) 19 mars 1985 voir colonne 1, lignes 30-45; colonne 2, lignes 47-51; colonne 4, lignes 61-65; colonne 5, lignes 9-17, colonne 5, ligne 64 - colonne 6, ligne 8; colonne 8, lignes 23-28; colonne 9, lignes 4-12; colonne 10, lignes 31-36; colonne 12, lignes 42-45; figures 1,5A	1
A	--	2,3,5
Y	IBM Technical Disclosure Bulletin, volume 27, no. 11, avril 1985, (New York, US), "Beeper - electronic mail and reminder paging system", page 6367 voir le document en entier	1
X	EP, A, 0087849 (VMX INC.) 7 septembre 1983 voir page 7, lignes 13-28; page 9, lignes 5-19; page 45, lignes 19-33;	1-3.
<p><sup>*</sup> Catégories spéciales de documents cités <sup>11</sup></p> <p>« A » document définissant l'état général de la technique, non considéré comme particulièrement pertinent</p> <p>« E » document antérieur, mais publié à la date de dépôt international ou après cette date</p> <p>« L » document pouvant jeter un doute sur une revendication de priorité ou cité pour déterminer la date de publication d'une autre citation ou pour une raison spéciale (telle qu'indiquée)</p> <p>« O » document se référant à une divulgation orale, à un usage, à une exposition ou tous autres moyens</p> <p>« P » document publié avant la date de dépôt international, mais postérieurement à la date de priorité revendiquée</p> <p>« T » document ultérieur publié postérieurement à la date de dépôt international ou à la date de priorité et n'appartenant pas à l'état de la technique définissant, mais cité pour comprendre le principe ou la théorie constituant la base de l'invention</p> <p>« X » document particulièrement pertinent: l'invention revendiquée ne peut être considérée comme nouvelle ou comme impliquant une activité inventive</p> <p>« Y » document particulièrement pertinent: l'invention revendiquée ne peut être considérée comme impliquant une activité inventive lorsque le document est associé à un ou plusieurs autres documents de même nature, cette combinaison étant évidente pour une personne du métier.</p> <p>« Z » document qui fait partie de la même famille de brevets</p>		
<b>IV. CERTIFICATION</b>		
Date à laquelle la recherche internationale a été effectivement achevée 2 mai 1989	Date d'expédition du présent rapport de recherche internationale 05.05.89	
Administration chargée de la recherche internationale <b>OFFICE EUROPEEN DES BREVETS</b>	Signature du fonctionnaire autorisé  <b>P.C.G. VAN DER PUTTEN</b>	

III. DOCUMENTS CONSIDÉRÉS COMME PERTINENTS		(SUITE DES RENSEIGNEMENTS INDICUÉS SUR LA DEUXIÈME FEUILLE)
Catégorie *	Identification des documents cités, avec indication, si nécessaire, des passages pertinents	N° des revendications visées
	page 54, lignes 16-35; page 66, lignes 27-31	
A	--	4-6
A	Patent Abstracts of Japan, volume 9, no. 325 (E-368)(2048), 20 décembre 1985, & JP, A, 60157363 (FUJITSU K.K.) 17 août 1985 voir le document en entier	1
A	--	1,4
A	Patent Abstracts of Japan, volume 4, no. 181 (E-37)(663), 13 décembre 1980, & JP, A, 55123268 (FUJITSU K.K.) 22 septembre 1980 voir le document en entier	

ANNEXE AU RAPPORT DE RECHERCHE INTERNATIONALE  
RELATIF A LA DEMANDE INTERNATIONALE NO.

EP 8800814  
SA 24135

La présente annexe indique les membres de la famille de brevets relatifs aux documents brevets cités dans le rapport de recherche internationale visé ci-dessus.  
Lesdits membres sont contenus au fichier informatique de l'Office européen des brevets à la date du 26/05/89  
Les renseignements fournis sont donnés à titre indicatif et n'engagent pas la responsabilité de l'Office européen des brevets.

Document brevet cité au rapport de recherche	Date de publication	Membre(s) de la famille de brevets)	Date de publication
US-A- 4506111	19-03-85	JP-A- 58040965	10-03-83
EP-A- 0087849	07-09-83	US-A- 4371752	01-02-83
		CA-A- 1157551	22-11-83
		EP-A, B 0029938	10-06-81
		US-A- 4581486	08-04-86
		US-A- 4602129	22-07-86
		US-A- 4640991	03-02-87
		US-A- 4585906	29-04-86
		US-A- 4580012	01-04-86
		US-A- 4652700	24-03-87

EPPO FORM 100471

Pour tout renseignement concernant cette annexe : voir Journal Officiel de l'Office européen des brevets, No.12/82

## Electronic Acknowledgement Receipt

<b>EFS ID:</b>	6679060
<b>Application Number:</b>	90010416
<b>International Application Number:</b>	
<b>Confirmation Number:</b>	1061
<b>Title of Invention:</b>	Point-to-Point Internet Protocol
<b>First Named Inventor/Applicant Name:</b>	6108704
<b>Customer Number:</b>	42624
<b>Filer:</b>	Michael R. Casey
<b>Filer Authorized By:</b>	
<b>Attorney Docket Number:</b>	2655-0188
<b>Receipt Date:</b>	21-DEC-2009
<b>Filing Date:</b>	17-FEB-2009
<b>Time Stamp:</b>	14:46:31
<b>Application Type:</b>	Reexam (Third Party)

### Payment information:

Submitted with Payment	no
------------------------	----

### File Listing:

Document Number	Document Description	File Name	File Size(Bytes)/ Message Digest	Multi Part /.zip	Pages (if appl.)
1	Transmittal Letter	20091221_IDS_0188.pdf	119097 <small>131ae576d9ad4d158ac5abf34d1e8d5ba49f1cb0</small>	no	2

### Warnings:

### Information:

2	Information Disclosure Statement (IDS) Filed (SB/08)	20091221_1449_0188.pdf	1339303	no	10
			53ff4929f1108d21ec0adfc6ea48c214289e a86		
<b>Warnings:</b>					
<b>Information:</b>					
This is not an USPTO supplied IDS fillable form					
3	Foreign Reference	F0000.pdf	5776244	no	23
			50b55d4ed8a0d2f0196d6f6864d30cd61 3945d		
<b>Warnings:</b>					
<b>Information:</b>					
4	NPL Documents	NP0000.pdf	838513	no	12
			66a00754dc0d285ad4ae2a16eb29ca5535e 7e21e		
<b>Warnings:</b>					
<b>Information:</b>					
5	NPL Documents	NP0001.pdf	1241879	no	10
			818dbd15bedf8fb9a16d81693660208beb 586e2		
<b>Warnings:</b>					
<b>Information:</b>					
6	NPL Documents	NP0002.pdf	3422190	no	10
			688985d625e78fd99ff3116cd6b41act1b9 a1c		
<b>Warnings:</b>					
<b>Information:</b>					
7	NPL Documents	NP0003.pdf	526182	no	13
			629622e18272de514a8b523c8c558d727e 27251		
<b>Warnings:</b>					
<b>Information:</b>					
8	NPL Documents	NP0004.pdf	4227094	no	79
			d64e00a142a7bd72a370ba0d27aa633753a fd920		
<b>Warnings:</b>					
<b>Information:</b>					
9	NPL Documents	NP0005.pdf	208083	no	4
			31eca1a7e09cc7b2cc282768adb8614ede8 9ac91		
<b>Warnings:</b>					
<b>Information:</b>					
10	NPL Documents	NP0006.pdf	425889	no	8
			6ae5def5036f84cfae5ffbb37fb62bac02050 75b		

<b>Warnings:</b>					
<b>Information:</b>					
11	NPL Documents	NP0007.pdf	302525 f1bc0d9816e9f047696df85bb96a2152572d46a	no	5
<b>Warnings:</b>					
<b>Information:</b>					
12	NPL Documents	NP0008.pdf	1330198 2bd474421abf934b7ca1311c58fd96c845560c	no	6
<b>Warnings:</b>					
<b>Information:</b>					
13	NPL Documents	NP0009.pdf	833351 19f45b96990ce8af408921cca17030759a5c19b	no	17
<b>Warnings:</b>					
<b>Information:</b>					
14	NPL Documents	NP0010.pdf	2368381 9fa3e1672017796e58e317584fd708dab333c69f	no	16
<b>Warnings:</b>					
<b>Information:</b>					
15	NPL Documents	NP0011.pdf	46655 097bb5fe01f7fd3f9596a67cb1f4eae95ed2cea	no	1
<b>Warnings:</b>					
<b>Information:</b>					
16	NPL Documents	NP0012.pdf	3918575 42e0839f8342ede5abb6ee1591af94e229f5820c9	no	63
<b>Warnings:</b>					
<b>Information:</b>					
17	NPL Documents	NP0013.pdf	1730069 ab452329d457eda501aea323e0e225d0ea2cfff95d	no	38
<b>Warnings:</b>					
<b>Information:</b>					
18	NPL Documents	NP0014.pdf	159215 419d8fd36ca8c8d9945917caa2e880b48e46ff67	no	4
<b>Warnings:</b>					
<b>Information:</b>					
19	NPL Documents	NP0015.pdf	112236	no	2

<b>Warnings:</b>					
<b>Information:</b>					
20	NPL Documents	NP0016.pdf	746742 ee6d3da204e570c757b7a88be05d667d0c d85a89	no	13
<b>Warnings:</b>					
<b>Information:</b>					
21	NPL Documents	NP0017.pdf	10192099 8bb5837e3483404a7764d5d6129a613537 c04cd6	no	137
<b>Warnings:</b>					
<b>Information:</b>					
22	NPL Documents	NP0018.pdf	1252953 e46b8e3413a412002c26041b8382cc75ff2d 3f05	no	2
<b>Warnings:</b>					
<b>Information:</b>					
23	NPL Documents	NP0019.pdf	355718 89ec17b41322acbb71f1318051e0c7b7303 28ce	no	6
<b>Warnings:</b>					
<b>Information:</b>					
24	NPL Documents	NP0020.pdf	2283804 86055346dfaed7d63f86617a14c5ae674498 2192	no	3
<b>Warnings:</b>					
<b>Information:</b>					
25	NPL Documents	NP0021.pdf	99080 fa8c39ed19be2d96019a536e215676703b7 9914a	no	2
<b>Warnings:</b>					
<b>Information:</b>					
26	NPL Documents	NP0022.pdf	1260193 20aa9df94b1c44010bd829d2b76133ca794f 4673	no	21
<b>Warnings:</b>					
<b>Information:</b>					
27	NPL Documents	NP0023.pdf	232340 2854ffc648d5a18610d8be922f9c18299cf9a 1e2	no	3
<b>Warnings:</b>					
<b>Information:</b>					
28	NPL Documents	NP0024.pdf	1118134	no	13



<b>Warnings:</b>					
<b>Information:</b>					
29	NPL Documents	NP0025.pdf	370243 4377b41ad1bc96ad25df31ad0ca994ddfbc63252	no	7
<b>Warnings:</b>					
<b>Information:</b>					
30	NPL Documents	NP0026.pdf	625297 dfd75e8b176ecd1a9f0dd5b7b72084a1c7eb5b	no	8
<b>Warnings:</b>					
<b>Information:</b>					
31	NPL Documents	NP0027.pdf	357801 9a7f7033503854ca9e5b7f7f34c5f58a5a8cb037	no	9
<b>Warnings:</b>					
<b>Information:</b>					
32	NPL Documents	NP0028.pdf	108767 146881b1059f216b875725260702c177b64445e	no	2
<b>Warnings:</b>					
<b>Information:</b>					
33	NPL Documents	NP0029.pdf	51345 0e0f4c96aa529db610cae76b8413382fa7f3332b	no	1
<b>Warnings:</b>					
<b>Information:</b>					
34	NPL Documents	NP0030.pdf	126229 361e07da86ba0c2f56897ae94e3e404db308ddfef	no	2
<b>Warnings:</b>					
<b>Information:</b>					
35	NPL Documents	NP0031.pdf	334366 31ca9e4e27adcf8ec2531972138dc0412f41895	no	7
<b>Warnings:</b>					
<b>Information:</b>					
36	NPL Documents	NP0032.pdf	283557 334be481ef41bd1f01d2d682d1ed3367a91fd5a1	no	6
<b>Warnings:</b>					
<b>Information:</b>					
37	NPL Documents	NP0033.pdf	984086	no	28

<b>Warnings:</b>					
<b>Information:</b>					
38	NPL Documents	NP0034.pdf	622455 5aac29f9118eae3b35dc4e22539675a85771dcd0	no	6
<b>Warnings:</b>					
<b>Information:</b>					
39	NPL Documents	NP0035.pdf	328173 0b3488e7ceb550715aee21189ae20323db9063b56	no	3
<b>Warnings:</b>					
<b>Information:</b>					
40	NPL Documents	NP0036.pdf	82042 68eac526727b55011a0d49ba2f44c23d974ed13	no	1
<b>Warnings:</b>					
<b>Information:</b>					
41	NPL Documents	NP0037.pdf	794823 0aea74a46b1b246ff8949464e562d047a43e2953	no	15
<b>Warnings:</b>					
<b>Information:</b>					
42	NPL Documents	NP0038.pdf	188253 7efb6563a12913ab6f1381e2382a625bd2c2d9954	no	4
<b>Warnings:</b>					
<b>Information:</b>					
43	NPL Documents	NP0039.pdf	1341931 a5f927cfc575f2babac8eb0642029cd227bd98	no	7
<b>Warnings:</b>					
<b>Information:</b>					
44	NPL Documents	NP0040.pdf	270279 0b1197f971354d7c09150aae4b4e789a8b60b30	no	4
<b>Warnings:</b>					
<b>Information:</b>					
45	NPL Documents	NP0041.pdf	515282 992f0ab171da4e34fe9e929239dfe14ca8a4730b	no	8
<b>Warnings:</b>					
<b>Information:</b>					
46	NPL Documents	NP0042.pdf	1374917	no	9

<b>Warnings:</b>					
<b>Information:</b>					
47	NPL Documents	NP0043.pdf	129364 25894fd723151278a66d67669a5ce131f418da9	no	2
<b>Warnings:</b>					
<b>Information:</b>					
48	NPL Documents	NP0044.pdf	4559066 556cac20bf65237c7450cbed0c1da914e34b0330	no	60
<b>Warnings:</b>					
<b>Information:</b>					
49	NPL Documents	NP0045.pdf	1125310 1d1a599b89fbfedb3d13523b9636e1bf453580783	no	2
<b>Warnings:</b>					
<b>Information:</b>					
50	NPL Documents	NP0046.pdf	129444 bfb6ec075e0838ae77053709645285863d22f668	no	1
<b>Warnings:</b>					
<b>Information:</b>					
51	NPL Documents	NP0047.pdf	372034 04829c731f16636e5bc5b0153ce0fbee08ba4fd4	no	6
<b>Warnings:</b>					
<b>Information:</b>					
52	NPL Documents	NP0048.pdf	1632756 c039f09efedcc08f0922b5349b1f9eb53b8fcf88	no	40
<b>Warnings:</b>					
<b>Information:</b>					
53	NPL Documents	NP0049.pdf	106160 811171af7c20d05a7ab94ff31f00955da707a10	no	1
<b>Warnings:</b>					
<b>Information:</b>					
54	NPL Documents	NP0050.pdf	84902 53e340b1c19c6f28b25adf24422de815645c5d38	no	2
<b>Warnings:</b>					
<b>Information:</b>					
55	NPL Documents	NP0051.pdf	34224	no	1

<b>Warnings:</b>					
<b>Information:</b>					
56	NPL Documents	NP0052.pdf	449807	no	14
			84918706614b66bf75d5ca17574df2a6d57da5a		
<b>Warnings:</b>					
<b>Information:</b>					
<b>Total Files Size (in bytes):</b>				63849655	
<p>This Acknowledgement Receipt evidences receipt on the noted date by the USPTO of the indicated documents, characterized by the applicant, and including page counts, where applicable. It serves as evidence of receipt similar to a Post Card, as described in MPEP 503.</p> <p><b><u>New Applications Under 35 U.S.C. 111</u></b>  If a new application is being filed and the application includes the necessary components for a filing date (see 37 CFR 1.53(b)-(d) and MPEP 506), a Filing Receipt (37 CFR 1.54) will be issued in due course and the date shown on this Acknowledgement Receipt will establish the filing date of the application.</p> <p><b><u>National Stage of an International Application under 35 U.S.C. 371</u></b>  If a timely submission to enter the national stage of an international application is compliant with the conditions of 35 U.S.C. 371 and other applicable requirements a Form PCT/DO/EO/903 indicating acceptance of the application as a national stage submission under 35 U.S.C. 371 will be issued in addition to the Filing Receipt, in due course.</p> <p><b><u>New International Application Filed with the USPTO as a Receiving Office</u></b>  If a new international application is being filed and the international application includes the necessary components for an international filing date (see PCT Article 11 and MPEP 1810), a Notification of the International Application Number and of the International Filing Date (Form PCT/RO/105) will be issued in due course, subject to prescriptions concerning national security, and the date shown on this Acknowledgement Receipt will establish the international filing date of the application.</p>					

IN THE UNITED STATES PATENT AND TRADEMARK OFFICE

In re PATENT APPLICATION OF:  
Net2Phone, Inc. (Patent No. 6,108,704)  
Control No.: 90/010,416  
Issue Date: August 22, 2000  
Title: **POINT-TO-POINT INTERNET  
PROTOCOL**

Attorney Docket: 2655-0188  
Group Art Unit: 3992  
Examiner: KOSOWSKI, Alexander  
Date: December 21, 2009  
Confirmation No.: 1061

INFORMATION DISCLOSURE STATEMENT

Hon. Commissioner of Patents  
P.O. Box 1450  
Alexandria, VA 22313-1450

Sir:

Pursuant to 37 C.F.R. § 1.56, the attention of the Patent and Trademark Office is hereby directed to the reference(s) listed on the attached PTO-1449. One copy of each non-U.S. Patent reference is attached. It is respectfully requested that the information be expressly considered during the prosecution of this application, and that the reference(s) be made of record therein and appear among the "References Cited" on any patent to issue therefrom.

The submission of any document herewith, which is not a statutory bar, is not intended that any such document constitutes prior art against any of the claims of the present application or is considered to be material to patentability as defined in 37 C.F.R. § 1.56(b). Applicants do not waive any rights to take any action which would be appropriate to antedate or otherwise remove as a competent reference against the claims of the present application.

In re Application of: Net2Phone, Inc.  
Control No.: 90/010,416  
Information Disclosure Statement dated December 21, 2009  
Page 2 of 2

**CHARGE STATEMENT: Deposit Account No. 501860, order no. 2655-0188.**

The Commissioner is hereby authorized to charge any fee specifically authorized hereafter, or any missing or insufficient fee(s) filed, or asserted to be filed, or which should have been filed herewith or concerning any paper filed hereafter, and which may be required under Rules 16-18 (missing or insufficiencies only) now or hereafter relative to this application and the resulting Official Document under Rule 20, or credit any overpayment, to our Accounting/Order Nos. shown above, for which purpose a duplicate copy of this sheet is attached

**This CHARGE STATEMENT does not authorize charge of the issue fee until/unless an issue fee transmittal sheet is filed.**

CUSTOMER NUMBER

**42624**

Respectfully submitted,

Davidson Berquist Jackson & Gowdey LLP  
4300 Wilson Blvd., 7th Floor,  
Arlington Virginia 22203  
Main: (703) 894-6400 • FAX: (703) 894-6430

By: /Michael R. Casey /

Michael R. Casey, Ph.D. (Reg. No.: 40,294)

CERTIFICATE OF SERVICE

The undersigned hereby certifies that, on December 21, 2009, the Information Disclosure Statement filed in Re-examination Control No. 90/010,416 was served by U.S. Priority Mail on Requestor as follows:

Blakely, Sokoloff, Taylor & Zafman LLP  
1279 Oakmead Parkway  
Sunnyvale, CA 94085-4040

Per agreement with the requester, copies of the references were included in electronic format on CD-ROM.

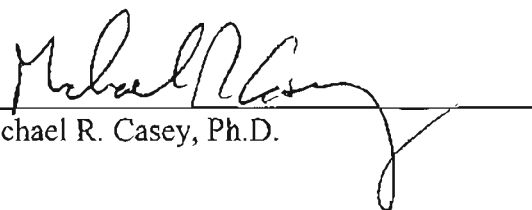
  
Michael R. Casey, Ph.D.

## Electronic Acknowledgement Receipt

<b>EFS ID:</b>	6679159
<b>Application Number:</b>	90010416
<b>International Application Number:</b>	
<b>Confirmation Number:</b>	1061
<b>Title of Invention:</b>	Point-to-Point Internet Protocol
<b>First Named Inventor/Applicant Name:</b>	6108704
<b>Customer Number:</b>	42624
<b>Filer:</b>	Michael R. Casey
<b>Filer Authorized By:</b>	
<b>Attorney Docket Number:</b>	2655-0188
<b>Receipt Date:</b>	21-DEC-2009
<b>Filing Date:</b>	17-FEB-2009
<b>Time Stamp:</b>	14:52:00
<b>Application Type:</b>	Reexam (Third Party)

### Payment information:

Submitted with Payment	no
------------------------	----

### File Listing:

Document Number	Document Description	File Name	File Size(Bytes)/ Message Digest	Multi Part /.zip	Pages (if appl.)
1	NPL Documents	NP0053.pdf	2382021 <small>54973552c2d219244652826c3b0a1338c806d616</small>	no	76

### Warnings:



2	NPL Documents	NP0054.pdf	332973	no	3
			9d15ea65e334ad7aceef41bf4937a511d7a53b58		
<b>Warnings:</b>					
<b>Information:</b>					
3	NPL Documents	NP0055.pdf	245043	no	2
			167884b41767a116e0ac7d9d647da9028132eb4		
<b>Warnings:</b>					
<b>Information:</b>					
4	NPL Documents	NP0056.pdf	20293336	no	120
			f8a2b73d5f4ed0a13f19c778f4462f02d3eaa6a7		
<b>Warnings:</b>					
<b>Information:</b>					
5	NPL Documents	NP0057.pdf	198007	no	2
			7c6dac2f326fa5d9b2e26d9bdcbfd9ae64a2f4f		
<b>Warnings:</b>					
<b>Information:</b>					
6	NPL Documents	NP0058.pdf	152156	no	4
			9a4f71e8c0868a24856b96ce159a37f83c1e553d		
<b>Warnings:</b>					
<b>Information:</b>					
7	NPL Documents	NP0059.pdf	714939	no	11
			4237ad09b674a5185893aee4f1389bad416ca699		
<b>Warnings:</b>					
<b>Information:</b>					
8	NPL Documents	NP0060.pdf	319167	no	8
			41e0bb0e0eaaad80560b1c62412d523dbc1b1a8		
<b>Warnings:</b>					
<b>Information:</b>					
9	NPL Documents	NP0061.pdf	1432267	no	21
			425b51cc4725a08491d4a2c62betad16186ac3d2		
<b>Warnings:</b>					
<b>Information:</b>					
10	NPL Documents	NP0062.pdf	1044072	no	9
			ebe3c41605b1878ac51b4d7d0bc9a04bd547544f		
<b>Warnings:</b>					
<b>Information:</b>					

11	Reexam Certificate of Service	20091221_COS_0188.pdf	57764	no	1
			65c7aa06bf9aac1893df9ded351d377dfc71383		

**Warnings:**

**Information:**

<b>Total Files Size (in bytes):</b>	27171745
-------------------------------------	----------

This Acknowledgement Receipt evidences receipt on the noted date by the USPTO of the indicated documents, characterized by the applicant, and including page counts, where applicable. It serves as evidence of receipt similar to a Post Card, as described in MPEP 503.

**New Applications Under 35 U.S.C. 111**

If a new application is being filed and the application includes the necessary components for a filing date (see 37 CFR 1.53(b)-(d) and MPEP 506), a Filing Receipt (37 CFR 1.54) will be issued in due course and the date shown on this Acknowledgement Receipt will establish the filing date of the application.

**National Stage of an International Application under 35 U.S.C. 371**

If a timely submission to enter the national stage of an international application is compliant with the conditions of 35 U.S.C. 371 and other applicable requirements a Form PCT/DO/EO/903 indicating acceptance of the application as a national stage submission under 35 U.S.C. 371 will be issued in addition to the Filing Receipt, in due course.

**New International Application Filed with the USPTO as a Receiving Office**

If a new international application is being filed and the international application includes the necessary components for an international filing date (see PCT Article 11 and MPEP 1810), a Notification of the International Application Number and of the International Filing Date (Form PCT/RO/105) will be issued in due course, subject to prescriptions concerning national security, and the date shown on this Acknowledgement Receipt will establish the international filing date of the application.

<b>INFORMATION DISCLOSURE STATEMENT BY APPLICANT</b> FORM PTO-1449 (modified)  Sheet 1 of 4	Reexam number	90/010,416
	First Named Inventor	Hutton
	Patent Under Re-Exam	6108704
	Issue Date	2000/08/22
	Group Art Unit	3992
	Examiner Name	KOSOWSKI, ALEXANDER J
	Attorney Docket No.	2655-0188
	Confirmation No.	1061

NON-PATENT REFERENCES			
Examiner Initials*	Cite No.	Non-patent Reference bibliographic information, where available	Notes
	1-1	David STROM, "Talking Telephony", Windows Sources, Ziff-Davis Publishing Company, September 1996, Vol. 4, No. 9, pages 6, 7, 10, 150-152, 157, 158, 163, 167, 169, 171, 174, 181, 184, 186, 195, 203, 208.	
	1-2	Deposition transcript of Andrew Green (dated Aug. December 30, 2008) in Net2Phone v. Skype et al. (Civil Action No. 06-2469-KSH-PS) in DCNJ	
	1-3	Deposition transcript of Daniel Mayer (dated Aug. 26, 2008) in Net2Phone v. Skype et al. (Civil Action No. 06-2469-KSH-PS) in DCNJ	
	1-4	Deposition transcript of Daniel Zwanziger (dated July 9, 2008) in Net2Phone v. Skype et al. (Civil Action No. 06-2469-KSH-PS) in DCNJ	
	1-5	Deposition transcript of expert Bruce Maggs (dated May 30, 2008) in Net2Phone v. Skype et al. (Civil Action No. 06-2469-KSH-PS) in DCNJ	
	1-6	Deposition transcript of expert Kevin Jeffay (dated May 20, 2008) in Net2Phone v. Skype et al. (Civil Action No. 06-2469-KSH-PS) in DCNJ	
	1-7	Deposition transcript of expert Stephen Kunin (dated June 3, 2008) in Net2Phone v. Skype et al. (Civil Action No. 06-2469-KSH-PS) in DCNJ	

Examiner Signature		Date Considered	
--------------------	--	-----------------	--

\*Examiner Initial if reference was considered, whether or not citation is in conformance with MPEP 609. Draw a line through citation if not in conformance and not considered. Include a copy of this form with next communication to applicant. Notes: If identified, the following is provided: EA = English Abstract, T = Translation, PT = Partial Translation, SOR = Statement of Relevancy, PF = Patent Family.

<b>INFORMATION DISCLOSURE STATEMENT BY APPLICANT</b> FORM PTO-1449 (modified)	Reexam number	90/010,416
	First Named Inventor	Hutton
	Patent Under Re-Exam	6108704
	Issue Date	2000/08/22
	Group Art Unit	3992
	Examiner Name	KOSOWSKI, ALEXANDER J
	Attorney Docket No.	2655-0188
	Confirmation No.	1061

Sheet 2 of 4

NON-PATENT REFERENCES			
Examiner Initials*	Cite No.	Non-patent Reference bibliographic information, where available	Notes
	2-1	Deposition transcript of former Tribal Voice employee and PowWow designer Paul Peterson (dated Apr. 9, 2008) in Net2Phone v. Skype et al. (Civil Action No. 06-2469-KSH-PS) in DCNJ	
	2-2	Deposition transcript of former VocalTec employee Alon Cohen (dated Mar. 11, 2008) in Net2Phone v. Skype et al. (Civil Action No. 06-2469-KSH-PS) in DCNJ	
	2-3	Deposition transcript of former VocalTec employee Lior Haramaty (dated Mar. 6, 2008) in Net2Phone v. Skype et al. (Civil Action No. 06-2469-KSH-PS) in DCNJ	
	2-4	Deposition transcript of inventor Craig Strickland (dated Sep. 19, 2007) in Net2Phone v. Skype et al. (Civil Action No. 06-2469-KSH-PS) in DCNJ	
	2-5	Deposition transcript of inventor Glenn Hutton (dated Aug. 24, 2007) (vol. 1) in Net2Phone v. Skype et al. (Civil Action No. 06-2469-KSH-PS) in DCNJ	
	2-6	Deposition transcript of inventor Glenn Hutton (dated Aug. 24, 2007) (vol. 2) in Net2Phone v. Skype et al. (Civil Action No. 06-2469-KSH-PS) in DCNJ	
	2-7	Deposition transcript of inventor Shane Mattaway (dated Sep. 10, 2007) (vol. 1) in Net2Phone v. Skype et al. (Civil Action No. 06-2469-KSH-PS) in DCNJ	

Examiner Signature		Date Considered	
--------------------	--	-----------------	--

\*Examiner: Initial if reference was considered, whether or not citation is in conformance with MPEP 609. Draw a line through citation if not in conformance and not considered. Include a copy of this form with next communication to applicant. Notes: If identified, the following is provided: EA = English Abstract, T = Translation, PT = Partial Translation, SOR = Statement of Relevancy, PF = Patent Family

<b>INFORMATION DISCLOSURE STATEMENT BY APPLICANT</b> FORM PTO-1449 (modified)	Reexam number	90/010,416
	First Named Inventor	Hutton
	Patent Under Re-Exam	6108704
	Issue Date	2000/08/22
	Group Art Unit	3992
	Examiner Name	KOSOWSKI, ALEXANDER J
	Attorney Docket No.	2655-0188
	Confirmation No.	1061

Sheet 3 of 4

NON-PATENT REFERENCES			
Examiner Initials*	Cite No.	Non-patent Reference bibliographic information, where available	Notes
	3-1	Deposition transcript of inventor Shane Mattaway (dated Sep. 10, 2007) (vol. 2) in Net2Phone v. Skype et al. (Civil Action No. 06-2469-KSH-PS) in DCNJ	
	3-2	Deposition transcript of prosecuting attorney Bruce Jobse (dated Jan. 1, 2008) in Net2Phone v. Skype et al. (Civil Action No. 06-2469-KSH-PS) in DCNJ	
	3-3	Deposition transcript of Sheldon Glashow (dated July 16, 2008) in Net2Phone v. Skype et al. (Civil Action No. 06-2469-KSH-PS) in DCNJ	
	3-4	Emad FARAG et al., "Structure and network control of a hierarchical mobile network architecture", IEEE Fourteenth Annual International Phoenix Conference on Computers and Communications, 03/1995, ISBN: 0-7803-2492-7, pp 671-677.	
	3-5	English translation of JP-06-62020 (dated 1994-03-04)	
	3-6	Huanxu PAN et al., "Analysis of a CCSS#7 Network supporting database services", IEEE International Conference on Information Engineering, 09/1993, ISBN: 0-7803-1445-X, pp. 193-197, vol. 1.	
	3-7	John E. GOODWIN, Project Gutenberg Alpha Edition of EMAIL 101, <a href="http://metalab.unc.edu/pub/docs/books/gutenberg/etext93/email025.txt">http://metalab.unc.edu/pub/docs/books/gutenberg/etext93/email025.txt</a> , July 1993.	

Examiner Signature		Date Considered	
--------------------	--	-----------------	--

\*Examiner: Initial if reference was considered, whether or not citation is in conformance with MPEP 609. Draw a line through citation if not in conformance and not considered. Include a copy of this form with next communication to applicant. Notes: If identified, the following is provided: EA = English Abstract, T = Translation, PT = Partial Translation, SOR = Statement of Relevancy, PF = Patent Family.

<b>INFORMATION DISCLOSURE STATEMENT BY APPLICANT</b> FORM PTO-1449 (modified)  Sheet 4 of 4	Reexam number	90/010,416
	First Named Inventor	Hutton
	Patent Under Re-Exam	6108704
	Issue Date	2000/08/22
	Group Art Unit	3992
	Examiner Name	KOSOWSKI, ALEXANDER J
	Attorney Docket No.	2655-0188
	Confirmation No.	1061

NON-PATENT REFERENCES			
Examiner Initials*	Cite No.	Non-patent Reference bibliographic information, where available	Notes
	4-1	Junichi Kimura, et al. "Voice/Data Multiplexing Transmission Methods", Kokai Japanese Patent, Kokai Sho 59-44140, pages 205-215, with English Abstract, English Translation, pages 1-24	
	4-2	Mark R. BROWN et al. "Special Edition: Using Netscape 2", Que Publishing, 1995, ISBN 0-7897-0612-1, pages 7-35, 37-56, 78, 83, 176, 301-320, 393, 395-467, 469-506.	
	4-3	Preston GRALLA, "How the Internet Works", Ziff-Davis Press, Emeryville, CA, c1997, pp. 34-37, 202-205, 214-215 and 272-275, ISBN 1-56276-552-3.	
	4-4		
	4-5		
	4-6		
	4-7		

Examiner Signature		Date Considered	
--------------------	--	-----------------	--

\*Examiner: Initial if reference was considered, whether or not citation is in conformance with MPEP 609. Draw a line through citation if not in conformance and not considered. Include a copy of this form with next communication to applicant. Notes: If identified, the following is provided: EA = English Abstract, T = Translation, PT = Partial Translation, SOR = Statement of Relevancy, PF = Patent Family.

**CERTIFICATE OF SERVICE**

The undersigned hereby certifies that, on January 26, 2010, the Information Disclosure Statement filed in Re-examination Control No. 90/010,416 was served by U.S. Priority Mail on Requestor as follows:

Blakely, Sokoloff, Taylor & Zafman LLP  
1279 Oakmead Parkway  
Sunnyvale, CA 94085-4040

Per agreement with the requester, copies of the references were included in electronic format on CD-ROM.

/ Michael R. Casey /

\_\_\_\_\_  
Michael R. Casey, Ph.D.

## Electronic Acknowledgement Receipt

<b>EFS ID:</b>	6885798
<b>Application Number:</b>	90010416
<b>International Application Number:</b>	
<b>Confirmation Number:</b>	1061
<b>Title of Invention:</b>	Point-to-Point Internet Protocol
<b>First Named Inventor/Applicant Name:</b>	6108704
<b>Customer Number:</b>	42624
<b>Filer:</b>	Michael R. Casey
<b>Filer Authorized By:</b>	
<b>Attorney Docket Number:</b>	2655-0188
<b>Receipt Date:</b>	26-JAN-2010
<b>Filing Date:</b>	17-FEB-2009
<b>Time Stamp:</b>	18:00:54
<b>Application Type:</b>	Reexam (Third Party)

### Payment information:

Submitted with Payment	no
------------------------	----

### File Listing:

Document Number	Document Description	File Name	File Size(Bytes)/ Message Digest	Multi Part /.zip	Pages (if appl.)
1	Transmittal Letter	20100126_IDS_0188.pdf	119112 <small>1e03e4b4c6c552016fa80447d8c943ceb9d a8e5</small>	no	2

### Warnings:

### Information:



2	Information Disclosure Statement (IDS) Filed (SB/08)	20100126_1449_0188.pdf	664089	no	4
			9a4a8091af9d89d71649e858dd386c135e542b1e		
<b>Warnings:</b>					
<b>Information:</b>					
This is not an USPTO supplied IDS fillable form					
3	Reexam Certificate of Service	20100126_COS_0188.pdf	51652	no	1
			0fc10a5793bc07722409dc9089b124da9474f9cd		
<b>Warnings:</b>					
<b>Information:</b>					
4	NPL Documents	NP0000.pdf	2849230	no	21
			fccf70e1c7a75070c48a44ce952700a979470617		
<b>Warnings:</b>					
<b>Information:</b>					
5	NPL Documents	NP0001.pdf	324894	no	165
			0d4e7d18798d0547ab9f7217bf438d32d4aca151		
<b>Warnings:</b>					
<b>Information:</b>					
6	NPL Documents	NP0002.pdf	158137	no	76
			9d019ba52ea92885a4de182f3a26e8340797d17		
<b>Warnings:</b>					
<b>Information:</b>					
7	NPL Documents	NP0003.pdf	197976	no	97
			e77951235711e2e7a11a53c2103667cbcc87ee4b		
<b>Warnings:</b>					
<b>Information:</b>					
8	NPL Documents	NP0004.pdf	536699	no	296
			a5f42c11f6a61da6ed373eb9beeafcb1cdbe410		
<b>Warnings:</b>					
<b>Information:</b>					
9	NPL Documents	NP0005.pdf	538883	no	310
			775254c12e40277ca609e2e4917ac10603dd77e1		
<b>Warnings:</b>					
<b>Information:</b>					
10	NPL Documents	NP0006.pdf	143967	no	30
			8dd5cd21d27fba76870157d2f1e035809b8f680		

<b>Warnings:</b>					
<b>Information:</b>					
11	NPL Documents	NP0007.pdf	234922 c54976a90b5f782a7b5261f39ab45e67de3 0392	no	123
<b>Warnings:</b>					
<b>Information:</b>					
12	NPL Documents	NP0008.pdf	243217 de51ab6bd3717584d8f259603d52b1b9fc1 b5a20	no	120
<b>Warnings:</b>					
<b>Information:</b>					
13	NPL Documents	NP0009.pdf	191407 64f22007d6f00c2d952577a5ee4b78103cd9 ed69	no	89
<b>Warnings:</b>					
<b>Information:</b>					
14	NPL Documents	NP0010.pdf	406575 d5366a0e76b1b131fe8198023425bc00052 85cc3	no	216
<b>Warnings:</b>					
<b>Information:</b>					
15	NPL Documents	NP0011.pdf	293003 11de56d0b56ce15be91de574e37335118ac e03bc	no	153
<b>Warnings:</b>					
<b>Information:</b>					
16	NPL Documents	NP0012.pdf	356895 f67059d2cddaef30c8b7315cdc87819a30f554 bb3	no	194
<b>Warnings:</b>					
<b>Information:</b>					
17	NPL Documents	NP0013.pdf	341088 ddb8b7e2ed765fd5b656445eddcc34b9b3e 3cb689	no	177
<b>Warnings:</b>					
<b>Information:</b>					
18	NPL Documents	NP0014.pdf	237011 efbc987cfb2c3e70586f860117db5267e9ed 47a0	no	116
<b>Warnings:</b>					
<b>Information:</b>					
19	NPL Documents	NP0015.pdf	390203	no	225

<b>Warnings:</b>					
<b>Information:</b>					
20	NPL Documents	NP0016.pdf	246519 7abb73e5f0bbdf6ca112d1b438a981bd59187d9	no	122
<b>Warnings:</b>					
<b>Information:</b>					
21	NPL Documents	NP0017.pdf	557280 bd59240ef179ad7b550b46e2e3e6987513ede89c	no	8
<b>Warnings:</b>					
<b>Information:</b>					
22	NPL Documents	NP0018.pdf	488130 b78dc26c39196504962b62c2554d073552db1348	no	28
<b>Warnings:</b>					
<b>Information:</b>					
23	NPL Documents	NP0019.pdf	381732 b7b1d0ed5f2041102da896eb14363c17bb22de6	no	5
<b>Warnings:</b>					
<b>Information:</b>					
24	NPL Documents	NP0020.pdf	2436121 78a7093d4c5233498053bdffd13ec7fa32915ed7	no	44
<b>Warnings:</b>					
<b>Information:</b>					
25	NPL Documents	NP0021.pdf	1315455 0599b13ab1c7fc807f2612c5d47ea8b8fd78d6	no	36
<b>Warnings:</b>					
<b>Information:</b>					
26	NPL Documents	NP0022.pdf	12867743 1b175ba39ec382d8eb4a37187275a4eff099ecc8	no	187
<b>Warnings:</b>					
<b>Information:</b>					
27	NPL Documents	NP0023.pdf	710975 182d26e9f78b2d565d519aadcd049bd3a98a69f	no	5
<b>Warnings:</b>					
<b>Information:</b>					
<b>Total Files Size (in bytes):</b>					27282915

This Acknowledgement Receipt evidences receipt on the noted date by the USPTO of the indicated documents, characterized by the applicant, and including page counts, where applicable. It serves as evidence of receipt similar to a Post Card, as described in MPEP 503.

**New Applications Under 35 U.S.C. 111**

If a new application is being filed and the application includes the necessary components for a filing date (see 37 CFR 1.53(b)-(d) and MPEP 506), a Filing Receipt (37 CFR 1.54) will be issued in due course and the date shown on this Acknowledgement Receipt will establish the filing date of the application.

**National Stage of an International Application under 35 U.S.C. 371**

If a timely submission to enter the national stage of an international application is compliant with the conditions of 35 U.S.C. 371 and other applicable requirements a Form PCT/DO/EO/903 indicating acceptance of the application as a national stage submission under 35 U.S.C. 371 will be issued in addition to the Filing Receipt, in due course.

**New International Application Filed with the USPTO as a Receiving Office**

If a new international application is being filed and the international application includes the necessary components for an international filing date (see PCT Article 11 and MPEP 1810), a Notification of the International Application Number and of the International Filing Date (Form PCT/RO/105) will be issued in due course, subject to prescriptions concerning national security, and the date shown on this Acknowledgement Receipt will establish the international filing date of the application.

IN THE UNITED STATES PATENT AND TRADEMARK OFFICE

In re PATENT APPLICATION OF:  
Net2Phone, Inc. (Patent No. 6,108,704)  
Control No.: 90/010,416  
Issue Date: August 22, 2000  
Title: **POINT-TO-POINT INTERNET  
PROTOCOL**

Attorney Docket: 2655-0188  
Group Art Unit: 3992  
Examiner: KOSOWSKI, Alexander  
Date: January 26, 2010  
Confirmation No.: 1061

INFORMATION DISCLOSURE STATEMENT

Hon. Commissioner of Patents  
P.O. Box 1450  
Alexandria, VA 22313-1450

Sir:

Pursuant to 37 C.F.R. § 1.56, the attention of the Patent and Trademark Office is hereby directed to the reference(s) listed on the attached PTO-1449. One copy of each non-U.S. Patent reference is attached. It is respectfully requested that the information be expressly considered during the prosecution of this application, and that the reference(s) be made of record therein and appear among the "References Cited" on any patent to issue therefrom.

The submission of any document herewith, which is not a statutory bar, is not intended that any such document constitutes prior art against any of the claims of the present application or is considered to be material to patentability as defined in 37 C.F.R. § 1.56(b). Applicants do not waive any rights to take any action which would be appropriate to antedate or otherwise remove as a competent reference against the claims of the present application.

In re Application of: Net2Phone, Inc.  
Control No.: 90/010,416  
Information Disclosure Statement dated January 26, 2010  
Page 2 of 2

**CHARGE STATEMENT: Deposit Account No. 501860, order no. 2655-0188.**

The Commissioner is hereby authorized to charge any fee specifically authorized hereafter, or any missing or insufficient fee(s) filed, or asserted to be filed, or which should have been filed herewith or concerning any paper filed hereafter, and which may be required under Rules 16-18 (missing or insufficiencies only) now or hereafter relative to this application and the resulting Official Document under Rule 20, or credit any overpayment, to our Accounting/Order Nos. shown above, for which purpose a duplicate copy of this sheet is attached

**This CHARGE STATEMENT does not authorize charge of the issue fee until/unless an issue fee transmittal sheet is filed.**

CUSTOMER NUMBER

**42624**

Respectfully submitted,

Davidson Berquist Jackson & Gowdey LLP  
4300 Wilson Blvd., 7th Floor,  
Arlington Virginia 22203  
Main: (703) 894-6400 • FAX: (703) 894-6430

By: /Michael R. Casey /

Michael R. Casey, Ph.D. (Reg. No.: 40,294)

**INFORMATION DISCLOSURE  
STATEMENT BY APPLICANT**  
FORM PTO-1449 (modified)

Sheet 1 of 1

Reexam number	90/010,416
First Named Inventor	Hutton
Patent Under Re-Exam	6108704
Issue Date	2000/08/22
Group Art Unit	3992
Examiner Name	KOSOWSKI, ALEXANDER J
Attorney Docket No.	2655-0188
Confirmation No.	1061

**NON-PATENT REFERENCES**

Examiner Initials*	Cite No.	Non-patent Reference bibliographic information, where available	Notes
	1-1	(Redacted) Expert Report of Professor Bruce M. Maggs (as Supplemented Sept. 9, 2008) in Net2Phone v. Skype et al. (Civil Action No. 06-2469-KSH-PS) in DCNJ	
	1-2	(Redacted) Responsive Expert Report of Kevin Jeffay, Ph D. in Net2Phone v. Skype et al. (Civil Action No. 06-2469-KSH-PS) in DCNJ, Aug. 7, 2008	
	1-3	VocalChat GTI Information file, believed to be included with VocalChat GTI version 2.12 dated September, 1994	
	1-4	VocalChat GTI README.TXT for Version 2.12 Beta, dated September, 1994	
	1-5	VocalChat GTI Troubleshooting.Inf, believed to be included with VocalChat GTI version 2.12 dated September, 1994	
	1-6		
	1-7		

Examiner Signature		Date Considered	
--------------------	--	-----------------	--

\*Examiner: Initial if reference was considered, whether or not citation is in conformance with MPEP 609. Draw a line through citation if not in conformance and not considered. Include a copy of this form with next communication to applicant. Notes: If identified, the following is provided: EA = English Abstract, T = Translation, PF = Patent Family.

**CERTIFICATE OF SERVICE**

The undersigned hereby certifies that, on February 24, 2010, the Information Disclosure Statement filed in Re-examination Control No. 90/010,416 was served by U.S. Priority Mail on Requestor as follows:

Blakely, Sokoloff, Taylor & Zafman LLP  
1279 Oakmead Parkway  
Sunnyvale, CA 94085-4040

Per agreement with the requester, copies of the references were included in electronic format on CD-ROM.

/ Michael R. Casey /

---

Michael R. Casey, Ph.D.



## Electronic Acknowledgement Receipt

<b>EFS ID:</b>	7080096
<b>Application Number:</b>	90010416
<b>International Application Number:</b>	
<b>Confirmation Number:</b>	1061
<b>Title of Invention:</b>	Point-to-Point Internet Protocol
<b>First Named Inventor/Applicant Name:</b>	6108704
<b>Customer Number:</b>	42624
<b>Filer:</b>	Michael R. Casey
<b>Filer Authorized By:</b>	
<b>Attorney Docket Number:</b>	2655-0188
<b>Receipt Date:</b>	24-FEB-2010
<b>Filing Date:</b>	17-FEB-2009
<b>Time Stamp:</b>	16:34:30
<b>Application Type:</b>	Reexam (Third Party)

### Payment information:

Submitted with Payment	no
------------------------	----

### File Listing:

Document Number	Document Description	File Name	File Size(Bytes)/ Message Digest	Multi Part /.zip	Pages (if appl.)
1	Transmittal Letter	20100224_IDS_0188.pdf	122003 <small>78fc751f07b54266ab864520e65d7048e4f e07d</small>	no	2

### Warnings:

### Information:

2	Information Disclosure Statement (IDS) Filed (SB/08)	20100224_0188_1449.pdf	145487	no	1
			2f755ced96462a53a048dd398cc46ce20b5ba618		
<b>Warnings:</b>					
<b>Information:</b>					
This is not an USPTO supplied IDS fillable form					
3	NPL Documents	NP0000.pdf	1979901	no	555
			a449a91e441753b8056cd6c68a2596713f56a7e8		
<b>Warnings:</b>					
<b>Information:</b>					
4	NPL Documents	NP0001.pdf	19102486	no	379
			44db3a22520e559a2aa39b3ab3a6d2d99f77c3acb9		
<b>Warnings:</b>					
<b>Information:</b>					
5	NPL Documents	NP0002.pdf	459371	no	14
			1487bd49c03d60e47137272cc06b82f35b1425		
<b>Warnings:</b>					
<b>Information:</b>					
6	NPL Documents	NP0003.pdf	31729	no	2
			3c3fa76b6f608e01672697686901d4f92bb7cc47		
<b>Warnings:</b>					
<b>Information:</b>					
7	NPL Documents	NP0004.pdf	1920797	no	33
			31dd0b006d48147ce4ed2f5ce4a54e94b15e2bb		
<b>Warnings:</b>					
<b>Information:</b>					
8	Reexam Certificate of Service	20100224_COS_0188.pdf	52456	no	1
			b13179ad41104556ce0621a669cf296af8d4dda		
<b>Warnings:</b>					
<b>Information:</b>					
<b>Total Files Size (in bytes):</b>			23814230		

This Acknowledgement Receipt evidences receipt on the noted date by the USPTO of the indicated documents, characterized by the applicant, and including page counts, where applicable. It serves as evidence of receipt similar to a Post Card, as described in MPEP 503.

**New Applications Under 35 U.S.C. 111**

If a new application is being filed and the application includes the necessary components for a filing date (see 37 CFR 1.53(b)-(d) and MPEP 506), a Filing Receipt (37 CFR 1.54) will be issued in due course and the date shown on this Acknowledgement Receipt will establish the filing date of the application.

**National Stage of an International Application under 35 U.S.C. 371**

If a timely submission to enter the national stage of an international application is compliant with the conditions of 35 U.S.C. 371 and other applicable requirements a Form PCT/DO/EO/903 indicating acceptance of the application as a national stage submission under 35 U.S.C. 371 will be issued in addition to the Filing Receipt, in due course.

**New International Application Filed with the USPTO as a Receiving Office**

If a new international application is being filed and the international application includes the necessary components for an international filing date (see PCT Article 11 and MPEP 1810), a Notification of the International Application Number and of the International Filing Date (Form PCT/RO/105) will be issued in due course, subject to prescriptions concerning national security, and the date shown on this Acknowledgement Receipt will establish the international filing date of the application.

IN THE UNITED STATES PATENT AND TRADEMARK OFFICE

In re PATENT APPLICATION OF:  
Net2Phone, Inc. (Patent No. 6,108,704)  
Control No.: 90/010,416  
Issue Date: August 22, 2000  
Title: **POINT-TO-POINT INTERNET  
PROTOCOL**

Attorney Docket: 2655-0188  
Group Art Unit: 3992  
Examiner: KOSOWSKI, Alexander  
Date: February 24, 2010  
Confirmation No.: 1061

INFORMATION DISCLOSURE STATEMENT

Hon. Commissioner of Patents  
P.O. Box 1450  
Alexandria, VA 22313-1450

Sir:

Pursuant to 37 C.F.R. § 1.56, the attention of the Patent and Trademark Office is hereby directed to the reference(s) listed on the attached PTO-1449. One copy of each non-U.S. Patent reference is attached. It is respectfully requested that the information be expressly considered during the prosecution of this application, and that the reference(s) be made of record therein and appear among the "References Cited" on any patent to issue therefrom.

The submission of any document herewith, which is not a statutory bar, is not intended that any such document constitutes prior art against any of the claims of the present application or is considered to be material to patentability as defined in 37 C.F.R. § 1.56(b). Applicants do not waive any rights to take any action which would be appropriate to antedate or otherwise remove as a competent reference against the claims of the present application.

It is noted that References 1-1 and 1-2 are Redacted expert reports. Those reports have been redacted to protect third party confidential information.

References 1-3 and 1-5 are printed copies of “.inf” files that are alleged to have been distributed with the VocalChat GTI version 2.12 Beta which is referenced in Reference 1-4.

**CHARGE STATEMENT: Deposit Account No. 501860, order no. 2655-0188.**

The Commissioner is hereby authorized to charge any fee specifically authorized hereafter, or any missing or insufficient fee(s) filed, or asserted to be filed, or which should have been filed herewith or concerning any paper filed hereafter, and which may be required under Rules 16-18 (missing or insufficiencies only) now or hereafter relative to this application and the resulting Official Document under Rule 20, or credit any overpayment, to our Accounting/Order Nos. shown above, for which purpose a duplicate copy of this sheet is attached

**This CHARGE STATEMENT does not authorize charge of the issue fee until/unless an issue fee transmittal sheet is filed.**

CUSTOMER NUMBER

**42624**

Davidson Berquist Jackson & Gowdey LLP  
4300 Wilson Blvd., 7th Floor,  
Arlington Virginia 22203  
Main: (703) 894-6400 • FAX: (703) 894-6430

Respectfully submitted,

By: /Michael R. Casey /

Michael R. Casey, Ph.D. (Reg. No.: 40,294)

RECEIVED

MAR 05 2010

COMMUNICATIONS SECTION

In re PATENT APPLICATION OF:  
Net2Phone, Inc. (Patent No. 6,108,704)  
Control No.: 90/010,416  
Issue Date: August 22, 2000  
Title: **POINT-TO-POINT INTERNET  
PROTOCOL**

Attorney Docket: 2655-0188  
Group Art Unit: 3992  
Examiner: KOSOWSKI, Alexander  
Date: March 5, 2010  
Confirmation No.: 1061

**TRANSMITTAL LETTER**

This compact disc is in the IBM-PC format and compatible with MS-Windows-based systems. The files contained on the compact disc are:

File Date	File Time	File Size (bytes)	File Name
03/05/2010	02:47 PM	574	files.txt
02/02/2010	11:28 AM	23,886	info.hlp
03/05/2010	01:55 PM	1,517	README.TXT
03/05/2010	01:55 PM	233,282	setup.exe
02/02/2010	11:28 AM	125,066	trouble.hlp
03/05/2010	01:55 PM	885,233	VOCLCHAT.001

The text of this file is contained in the file: files.txt.

CUSTOMER NUMBER

**42624**

Davidson Berquist Jackson & Gowdey LLP  
4300 Wilson Blvd., 7th Floor,  
Arlington Virginia 22203  
Main: (703) 894-6400 • FAX: (703) 894-6430

Respectfully submitted,

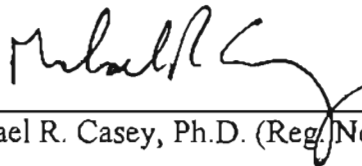
By: 

Michael R. Casey, Ph.D. (Reg. No.: 40,294)

RECEIVED

MAR 05 2010

CERTIFICATE OF SERVICE

CENTRAL INTELLIGENCE AGENCY

The undersigned hereby certifies that, on March 5, 2010, the Information Disclosure Statement filed in Re-examination Control No. 90/010,416 was served by U.S. Priority Mail on Requestor as follows:

Blakely, Sokoloff, Taylor & Zafman LLP  
1279 Oakmead Parkway  
Sunnyvale, CA 94085-4040

Per agreement with the requester, copies of the references were included in electronic format on CD-ROM.

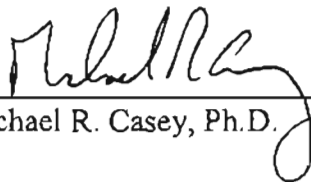
  
\_\_\_\_\_  
Michael R. Casey, Ph.D.

RECEIVED

MAR 05 2010

*Reexam*



**IN THE UNITED STATES PATENT AND TRADEMARK OFFICE**

In re PATENT APPLICATION OF:

Net2Phone, Inc. (Patent No. 6,108,704)

Control No.: 90/010,416

Issue Date: August 22, 2000

Title: **POINT-TO-POINT INTERNET  
PROTOCOL**

Attorney Docket: 2655-0188

Group Art Unit: 3992

Examiner: KOSOWSKI, Alexander

Date: March 5, 2010

Confirmation No.: 1061

**INFORMATION DISCLOSURE STATEMENT**

Hon. Commissioner of Patents  
P.O. Box 1450  
Alexandria, VA 22313-1450

Sir:

Pursuant to 37 C.F.R. § 1.56, the attention of the Patent and Trademark Office is hereby directed to the reference(s) listed on the attached PTO-1449. One copy of each non-U.S. Patent reference is attached. It is respectfully requested that the information be expressly considered during the prosecution of this application, and that the reference(s) be made of record therein and appear among the "References Cited" on any patent to issue therefrom.

The submission of any document herewith, which is not a statutory bar, is not intended that any such document constitutes prior art against any of the claims of the present application or is considered to be material to patentability as defined in 37 C.F.R. § 1.56(b). Applicants do not waive any rights to take any action which would be appropriate to antedate or otherwise remove as a competent reference against the claims of the present application.



The enclosed CD-ROM includes electronic copies of the help files (.hlp files) filed in the IDS submitted February 24, 2010 (as References 1-3 and 1-5) which were inadvertently referred to as “.inf” files in that IDS. The enclosed CD-ROM further includes a copy of the VocalChat GTI installation program (setup.exe) and its corresponding data file (vocchat.001). As described in the Redacted expert reports (References 1-1 and 1-2 of the IDS dated February 24, 2010), the VocalChat GTI software (including the .hlp files and the README.TXT file) is alleged to have been distributed more than one year prior to the effective filing date of this application.

**CHARGE STATEMENT: Deposit Account No. 501860, order no. 2655-0188.**

The Commissioner is hereby authorized to charge any fee specifically authorized hereafter, or any missing or insufficient fee(s) filed, or asserted to be filed, or which should have been filed herewith or concerning any paper filed hereafter, and which may be required under Rules 16-18 (missing or insufficiencies only) now or hereafter relative to this application and the resulting Official Document under Rule 20, or credit any overpayment, to our Accounting/Order Nos. shown above, for which purpose a duplicate copy of this sheet is attached

**This CHARGE STATEMENT does not authorize charge of the issue fee until/unless an issue fee transmittal sheet is filed.**

CUSTOMER NUMBER

**42624**

Davidson Berquist Jackson & Gowdey LLP  
4300 Wilson Blvd., 7th Floor,  
Arlington Virginia 22203  
Main: (703) 894-6400 • FAX: (703) 894-6430

Respectfully submitted,

By:



Michael R. Casey, Ph.D. (Reg. No.: 40,294)

MAR 05 2010

CENTRAL

<b>INFORMATION DISCLOSURE STATEMENT BY APPLICANT</b> FORM PTO-1449 (modified)  Sheet 1 of 1	Reexam number	90/010,416
	First Named Inventor	Hutton
	Patent Under Re-Exam	6108704
	Issue Date	2000/08/22
	Group Art Unit	3992
	Examiner Name	KOSOWSKI, ALEXANDER J
	Attorney Docket No.	2655-0188
	Confirmation No.	1061

NON-PATENT REFERENCES			
Examiner Initials*	Cite No.	Non-patent Reference bibliographic information, where available	Notes
	1-1	CD-ROM including VocalChat GTI Version 2.12 Software (including .hlp files and README.TXT file), alleged to be dated September, 1994	
	1-2		
	1-3		
	1-4		
	1-5		
	1-6		
	1-7		

Examiner Signature		Date Considered	
--------------------	--	-----------------	--

\*Examiner: Initial if reference was considered, whether or not citation is in conformance with MPEP 609. Draw a line through citation if not in conformance and not considered. Include a copy of this form with next communication to applicant. Notes: If identified, the following is provided: EA = English Abstract, T = Translation, PT = Partial Translation, SOR = Statement of Relevancy, PF = Patent Family.

# ARTIFACT SHEET

Enter artifact number below. Artifact number is application number + artifact type code (see list below) + sequential letter (A, B, C ...). The first artifact folder for an artifact type receives the letter A, the second B, etc..  
Examples: 59123456PA, 59123456PB, 59123456ZA, 59123456ZB

90/0104165A

Indicate quantity of a single type of artifact received but not scanned. Create individual artifact folder/box and artifact number for each Artifact Type.



CD(s) containing:

computer program listing  
Doc Code: Computer  
pages of specification  
and/or sequence listing  
and/or table

Artifact Type Code: P



Doc Code: Artifact  
content unspecified or combined  
Doc Code: Artifact

Artifact Type Code: S

Artifact Type Code: U

Stapled Set(s) Color Documents or B/W Photographs

Doc Code: Artifact    Artifact Type Code: C

Microfilm(s)

Doc Code: Artifact    Artifact Type Code: F

Video tape(s)

Doc Code: Artifact    Artifact Type Code: V

Model(s)

Doc Code: Artifact    Artifact Type Code: M

Bound Document(s)

Doc Code: Artifact    Artifact Type Code: B

Confidential Information Disclosure Statement or Other Documents  
marked Proprietary, Trade Secrets, Subject to Protective Order,  
Material Submitted under MPEP 724.02, etc.

Doc Code: Artifact    Artifact Type Code X

Other, description: \_\_\_\_\_

Doc Code: Artifact    Artifact Type Code: Z

March 8, 2004

# Litigation Search Report CRU 3999

Reexam Control No. 90/010,416

**TO: Alexander Kosowski**  
**Location: CRU**  
**Art Unit: 3992**  
**Date: 05/03/10**

**From: Shanette Brown**  
**Location: CRU 3999**  
**MDW 07C71**  
**Phone: (571) 272-6632**  
**Shanett.Brown@uspto.gov**

## Search Notes

RE: 90/010,416 - Litigation was found for US Patent Number: 6,108,704

Status (**OPEN**) 2:06cv2469 *Net2phone, Inc v. Ebay, Inc et al*

### Sources:

- 1) I performed a KeyCite Search in Westlaw, which retrieves all history on the patent including any litigation.
- 2) I performed a search on the patent in Lexis CourtLink for any open dockets or closed cases.
- 3) I performed a search in Lexis in the Federal Courts and Administrative Materials databases for any cases found.
- 4) I performed a search in Lexis in the IP Journal and Periodicals database for any articles on the patent.
- 5) I performed a search in Lexis in the news databases for any articles about the patent or any articles about litigation on this patent.

Date of Printing: May 03, 2010

**KEYCITE****C US PAT 6108704 POINT-TO-POINT INTERNET PROTOCOL, Assignee: NetSpeak Corporation (Aug 22, 2000)****History****Direct History**=> 1 **POINT-TO-POINT INTERNET PROTOCOL, US PAT 6108704, 2000 WL 1193732 (U.S. PTO Utility Aug 22, 2000) (NO. 08/533115)****Patent Family**2 **COMPUTER PROGRAM FOR ENABLING POINT-TO-POINT COMMUNICATION IN COMPUTER NETWORK, ESTABLISHES POINT-TO-POINT COMMUNICATION LINK BETWEEN PROCESSES OVER COMPUTER NETWORK, Derwent World Patents Legal 2000-685834****Assignments**

- 3 Action: ASSIGNMENT OF ASSIGNORS INTEREST (SEE DOCUMENT FOR DETAILS). Number of Pages: 032, (DATE RECORDED: Sep 12, 2005)
- 4 ACTION: ASSIGNMENT OF ASSIGNORS INTEREST (SEE DOCUMENT FOR DETAILS). NUMBER OF PAGES: 004, (DATE RECORDED: Jun 07, 1999)
- 5 Action: ASSIGNMENT OF ASSIGNORS INTEREST (SEE DOCUMENT FOR DETAILS). Number of Pages: 004, (DATE RECORDED: Feb 22, 1999)
- 6 ASSIGNEE(S): INTERNET TELEPHONE COMPANY, (DATE RECORDED: May 30, 1996)
- 7 ASSIGNEE(S): NETSPEAK CORPORATION, (DATE RECORDED: May 30, 1996)
- 8 ASSIGNEE(S): INTERNET TELEPHONE COMPANY, (DATE RECORDED: Jan 08, 1996)

**Patent Status Files**

.. Request for Re-Examination, (OG DATE: Apr 14, 2009)

**Docket Summaries**

10 "NET2PHONE, INC. v. EBAY, INC. ET AL", (D.N.J. Jun 01, 2006) (NO. 2:06CV02469), (35 USC 271 PATENT INFRINGEMENT)

© 2010 Thomson Reuters. All rights reserved.

**Prior Art (Coverage Begins 1976)**

- C** 11 ASYNCHRONOUS TRANSFER MODE COMMUNICATION SYSTEM, US PAT 5452296 Assignee: NEC Corporation, (U.S. PTO Utility 1995)
- C** 12 AUDIO COMMUNICATION SYSTEM FOR A COMPUTER NETWORK, US PAT 5434797 (U.S. PTO Utility 1995)
- C** 13 AUTOMATIC STATION IDENTIFICATION WHERE FUNCTION MODULES AUTOMATICALLY INITIALIZE, US PAT 5204669 Assignee: DataCard Corporation, (U.S. PTO Utility 1993)
- C** 14 BRIDGE-LIKE INTERNET PROTOCOL ROUTER, US PAT 5309437 Assignee: Digital Equipment Corporation, (U.S. PTO Utility 1994)
- C** 15 COMMUNICATIONS NETWORK DYNAMIC ADDRESSING ARRANGEMENT, US PAT 5166931 Assignee: AT&T Bell Laboratories, (U.S. PTO Utility 1992)
- C** 16 COMMUNICATIONS SYSTEM FOR AN ISDN AND A LAN, AND AN ISDN-LAN CONNECTION TERMINAL, US PAT 5400335 Assignee: Ricoh Company, Ltd., (U.S. PTO Utility 1995)
- C** 17 CONFERENCING OVER MULTIPLE TRANSPORTS, US PAT 5524110 Assignee: Intel Corporation, (U.S. PTO Utility 1996)
- C** 18 EXTENSION OF TWO PHASE COMMIT PROTOCOL TO DISTRIBUTED PARTICIPANTS, US PAT 5546582 Assignee: International Business Machines, (U.S. PTO Utility 1996)
- C** 19 HIGH PERFORMANCE MACHINE FOR SWITCHED COMMUNICATIONS IN A HETEROGENEOUS DATA PROCESSING NETWORK GATEWAY, US PAT 5463625 Assignee: International Business Machines, (U.S. PTO Utility 1995)
- C** 20 HUMAN MACHINE INTERFACE FOR TELEPHONE FEATURE INVOCATION, US PAT 5533110 Assignee: Mitel Corporation, (U.S. PTO Utility 1996)
- C** 21 LINK AND DISCOVERY PROTOCOLS FOR A RING INTERCONNECT ARCHITECTURE, US PAT 5457683 Assignee: Apple Computer, Inc., (U.S. PTO Utility 1995)
- C** 22 MESSAGE ROUTING SYSTEM FOR SHARED COMMUNICATION MEDIA NETWORKS, US PAT 5095480 (U.S. PTO Utility 1992)
- C** 23 METHOD AND APPARATUS FOR DELIVERING CALLING SERVICES, US PAT 5469500 Assignee: Voiceplex Corporation, (U.S. PTO Utility 1995)
- C** 24 METHOD AND SYSTEM OF MULTICAST ROUTING FOR GROUPS WITH A SINGLE TRANSMITTER, US PAT 5517494 Assignee: Apple Computer, Inc., (U.S. PTO Utility 1996)
- C** 25 METHOD FOR CONFIGURING AND OPERATING A TELECOMMUNICATION APPARATUS, US PAT 5544303 Assignee: International Business Machines, (U.S. PTO Utility 1996)
- C** 26 METHOD FOR POINT-TO-POINT COMMUNICATIONS WITHIN SECURE COMMUNICATION SYSTEMS, US PAT 5357571 Assignee: Motorola, Inc., (U.S. PTO Utility 1994)
- C** 27 METHODS AND APPARATUS FOR ROUTING PACKETS IN PACKET TRANSMISSION NETWORKS, US PAT 5309433 Assignee: International Business Machines Corp., (U.S. PTO Utility 1994)
- C** 28 MULTI-MEDIA INTEGRATED MESSAGE ARRANGEMENT, US PAT 5479411 Assignee: AT&T Corp., (U.S. PTO Utility 1995)

© 2010 Thomson Reuters. All rights reserved.

- C 29 MULTIMEDIA SERVER, US PAT 5581552 Assignee: AT&T, (U.S. PTO Utility 1996)
- P 30 MULTIPLE PROTOCOL ROUTING, US PAT 5430727 Assignee: Digital Equipment Corporation, (U.S. PTO Utility 1995)
- C 31 NETWORK-BASED MULTIMEDIA COMMUNICATIONS AND DIRECTORY SYSTEM AND METHOD OF OPERATION, US PAT 5740231 Assignee: Octel Communications Corporation, (U.S. PTO Utility 1998)
- C 32 NETWORK CONTROL SYSTEM AND METHOD, US PAT 5224095 Assignee: Johnson Service Company, (U.S. PTO Utility 1993)
- C 33 NETWORK MONITORING METHOD AND APPARATUS, US PAT 5430709 Assignee: Hewlett-Packard Company, (U.S. PTO Utility 1995)
- C 34 OBJECT-ORIENTED TELEPHONY SYSTEM, US PAT 5455854 Assignee: Taligent, Inc., (U.S. PTO Utility 1995)
- C 35 PROTOCOL SELECTION AND ADDRESS RESOLUTION FOR PROGRAMS RUNNING IN HETEROGENEOUS NETWORKS, US PAT 5425028 Assignee: International Business Machines, (U.S. PTO Utility 1995)
- C 36 RECONFIGURABLE, FAULT TOLERANT, MULTISTAGE INTERCONNECT NETWORK AND PROTOCOL, US PAT 5321813 Assignee: Teradata Corporation, (U.S. PTO Utility 1994)
- C 37 SCHEME FOR INTERLOCKING LINE CARD TO AN ADDRESS RECOGNITION ENGINE TO SUPPORT PLURALITY OF ROUTING AND BRIDGING PROTOCOLS BY USING NETWORK INFORMATION LOOK-UP DATABASE, US PAT 5524254 Assignee: Digital Equipment Corporation, (U.S. PTO Utility 1996)
- C 38 SHARED-PRICE CUSTOM VIDEO RENTALS VIA INTERACTIVE TV, US PAT 5291554 Assignee: TV Answer, Inc., (U.S. PTO Utility 1994)
- C 39 SHORTCUT NETWORK LAYER ROUTING FOR MOBILE HOSTS, US PAT 5442633 Assignee: International Business Machines, (U.S. PTO Utility 1995)
- C 40 SYSTEM FOR REVERSE ADDRESS RESOLUTION FOR REMOTE NETWORK DEVICE INDEPENDENT OF ITS PHYSICAL ADDRESS, US PAT 5526489 Assignee: 3Com Corporation, (U.S. PTO Utility 1996)
- C 41 UNIFIED MESSAGING SYSTEM AND METHOD, US PAT 5608786 Assignee: Alphanet Telecom Inc., (U.S. PTO Utility 1997)
- C 42 UTILIZATION OF REDUNDANT LINKS IN BRIDGED NETWORKS, US PAT 5150360 Assignee: Digital Equipment Corporation, (U.S. PTO Utility 1992)

---

**US District Court Civil Docket**

U.S. District - New Jersey  
(Newark)

**2:06cv2469**

**Net2phone, Inc v. Ebay, Inc et al**

This case was retrieved from the court on Monday, May 03, 2010

---

Date Filed: 06/01/2006	Class Code:
Assigned To: Judge Katharine S Hayden	Closed: No
Referred To: Magistrate Judge Patty Shwartz	Statute: 35:271
Nature of suit: Patent (830)	Jury Demand: Both
Cause: Patent Infringement	Demand Amount: \$0
Lead Docket: None	NOS Description: Patent
Other Docket: None	
Jurisdiction: Federal Question	

**Litigants****Attorneys**

Howard S Jonas  
Movant

Joseph P Lasala  
[COR LD NTC]  
McElroy, Deutsch, Mulvaney & Carpenter, LLP  
1300 Mount Kemble Avenue  
PO Box 2075  
Morristown, NJ 07962-2075  
USA  
(973) 993-8100  
Email: Jlasala@mdmc-Law.com

Ronald J Hedges  
Mediator  
[Term: 03/19/2009]

Ronald J Hedges  
[COR LD NTC]  
484 Washington Avenue  
Hackensack, NJ 07601  
USA  
Email: R\_HEDGES@LIVE.COM

Ronald J Hedges  
Special Master  
[Term: 03/19/2009]

Ronald J Hedges  
[COR LD NTC]  
484 Washington Avenue  
Hackensack, NJ 07601  
USA  
Email: R\_HEDGES@LIVE.COM

Net2phone, Inc  
Plaintiff

Joseph P Lasala  
[COR LD NTC]  
McElroy, Deutsch, Mulvaney & Carpenter, LLP  
1300 Mount Kemble Avenue  
PO Box 2075  
Morristown, NJ 07962-2075  
USA  
(973) 993-8100  
Email: Jlasala@mdmc-Law.com

William F O'Connor, Jr  
[COR LD NTC]  
McElroy, Deutsch Mulvaney & Carpenter, LLP  
1300 Mount Kemble Avenue  
PO Box 2075



Morristown , NJ 07962-2075  
USA  
973 993-8100  
Email: WOCONNOR@MDMC-Law.com

Maria A Savio  
[COR LD NTC]  
Gottlieb Rackman & Reisman  
270 Madison Avenue  
New York , NY 10016  
USA  
212-684-3900  
Email: Msavio@grr.com

Ebay, Inc  
Defendant

Kathleen M Fennelly  
[COR LD NTC]  
Graham, Curtin, PA  
4 Headquarters Plaza  
PO Box 1991  
Morristown , NJ 07962-1991  
USA  
(973) 292-1700  
Fax: (973) 292-1767  
Email: KFENNELLY@GRAHAMCURTIN.COM

Thomas R Curtin  
[COR LD NTC]  
Graham Curtin, PA  
4 Headquarters Plaza  
PO Box 1991  
Morristown , NJ 07962-1991  
USA  
(973) 292-1700  
Fax: (973) 292-1767  
Email: TCURTIN@GRAHAMCURTIN.COM

George C Jones  
[COR LD NTC]  
Graham Curtin, PA  
4 Headquarters Plaza  
PO Box 1991  
Morristown , NJ 07962  
USA  
(973) 292-1700  
Fax: (973) 292-1767  
Email: GJONES@GRAHAMCURTIN.COM

Skype Technologies SA  
Defendant

Kathleen M Fennelly  
[COR LD NTC]  
Graham, Curtin, PA  
4 Headquarters Plaza  
PO Box 1991  
Morristown , NJ 07962-1991  
USA  
(973) 292-1700  
Fax: (973) 292-1767  
Email: KFENNELLY@GRAHAMCURTIN.COM

Thomas R Curtin  
[COR LD NTC]  
Graham Curtin, PA  
4 Headquarters Plaza  
PO Box 1991  
Morristown , NJ 07962-1991  
USA  
(973) 292-1700  
Fax: (973) 292-1767  
Email: TCURTIN@GRAHAMCURTIN.COM

George C Jones

[COR LD NTC]  
Graham Curtin, PA  
4 Headquarters Plaza  
PO Box 1991  
Morristown , NJ 07962  
USA  
(973) 292-1700  
Fax: (973) 292-1767  
Email: GJONES@GRAHAMCURTIN.COM

Skype, Inc  
Defendant

Kathleen M Fennelly  
[COR LD NTC]  
Graham, Curtin, PA  
4 Headquarters Plaza  
PO Box 1991  
Morristown , NJ 07962-1991  
USA  
(973) 292-1700  
Fax: (973) 292-1767  
Email: KFENNELLY@GRAHAMCURTIN.COM

Thomas R Curtin  
[COR LD NTC]  
Graham Curtin, PA  
4 Headquarters Plaza  
PO Box 1991  
Morristown , NJ 07962-1991  
USA  
(973) 292-1700  
Fax: (973) 292-1767  
Email: TCURTIN@GRAHAMCURTIN.COM

George C Jones  
[COR LD NTC]  
Graham Curtin, PA  
4 Headquarters Plaza  
PO Box 1991  
Morristown , NJ 07962  
USA  
(973) 292-1700  
Fax: (973) 292-1767  
Email: GJONES@GRAHAMCURTIN.COM

John Does 1-10  
Defendant

Ebay, Inc  
Counter Claimant

Thomas R Curtin  
[COR LD NTC]  
Graham Curtin, PA  
4 Headquarters Plaza  
PO Box 1991  
Morristown , NJ 07962-1991  
USA  
(973) 292-1700  
Fax: (973) 292-1767  
Email: TCURTIN@GRAHAMCURTIN.COM

Kathleen M Fennelly  
[COR LD NTC]  
Graham, Curtin, PA  
4 Headquarters Plaza  
PO Box 1991  
Morristown , NJ 07962-1991  
USA  
(973) 292-1700  
Fax: (973) 292-1767  
Email: KFENNELLY@GRAHAMCURTIN.COM

Skype Technologies SA

Thomas R Curtin

Counter Claimant

[COR LD NTC]  
Graham Curtin, PA  
4 Headquarters Plaza  
PO Box 1991  
Morristown , NJ 07962-1991  
USA  
(973) 292-1700  
Fax: (973) 292-1767  
Email: TCURTIN@GRAHAMCURTIN.COM

Kathleen M Fennelly  
[COR LD NTC]  
Graham, Curtin, PA  
4 Headquarters Plaza  
PO Box 1991  
Morristown , NJ 07962-1991  
USA  
(973) 292-1700  
Fax: (973) 292-1767  
Email: KFENNELLY@GRAHAMCURTIN.COM

Skype, Inc  
Counter Claimant

Thomas R Curtin  
[COR LD NTC]  
Graham Curtin, PA  
4 Headquarters Plaza  
PO Box 1991  
Morristown , NJ 07962-1991  
USA  
(973) 292-1700  
Fax: (973) 292-1767  
Email: TCURTIN@GRAHAMCURTIN.COM

Kathleen M Fennelly  
[COR LD NTC]  
Graham, Curtin, PA  
4 Headquarters Plaza  
PO Box 1991  
Morristown , NJ 07962-1991  
USA  
(973) 292-1700  
Fax: (973) 292-1767  
Email: KFENNELLY@GRAHAMCURTIN.COM

Net2phone, Inc  
Counter Defendant

Joseph P Lasala  
[COR LD NTC]  
McElroy, Deutsch, Mulvaney & Carpenter, LLP  
1300 Mount Kemble Avenue  
PO Box 2075  
Morristown , NJ 07962-2075  
USA  
(973) 993-8100  
Email: Jlasala@mdmc-Law.com

Ebay, Inc  
Counter Claimant

Thomas R Curtin  
[COR LD NTC]  
Graham Curtin, PA  
4 Headquarters Plaza  
PO Box 1991  
Morristown , NJ 07962-1991  
USA  
(973) 292-1700  
Fax: (973) 292-1767  
Email: TCURTIN@GRAHAMCURTIN.COM

Kathleen M Fennelly  
[COR LD NTC]  
Graham, Curtin, PA  
4 Headquarters Plaza  
PO Box 1991

Morristown , NJ 07962-1991  
 USA  
 (973) 292-1700  
 Fax: (973) 292-1767  
 Email: KFENNELLY@GRAHAMCURTIN.COM

Skype Technologies SA  
 Counter Claimant

Thomas R Curtin  
 [COR LD NTC]  
 Graham Curtin, PA  
 4 Headquarters Plaza  
 PO Box 1991  
 Morristown , NJ 07962-1991  
 USA  
 (973) 292-1700  
 Fax: (973) 292-1767  
 Email: TCURTIN@GRAHAMCURTIN.COM

Kathleen M Fennelly  
 [COR LD NTC]  
 Graham, Curtin, PA  
 4 Headquarters Plaza  
 PO Box 1991  
 Morristown , NJ 07962-1991  
 USA  
 (973) 292-1700  
 Fax: (973) 292-1767  
 Email: KFENNELLY@GRAHAMCURTIN.COM

Skype, Inc  
 Counter Claimant

Thomas R Curtin  
 [COR LD NTC]  
 Graham Curtin, PA  
 4 Headquarters Plaza  
 PO Box 1991  
 Morristown , NJ 07962-1991  
 USA  
 (973) 292-1700  
 Fax: (973) 292-1767  
 Email: TCURTIN@GRAHAMCURTIN.COM

Kathleen M Fennelly  
 [COR LD NTC]  
 Graham, Curtin, PA  
 4 Headquarters Plaza  
 PO Box 1991  
 Morristown , NJ 07962-1991  
 USA  
 (973) 292-1700  
 Fax: (973) 292-1767  
 Email: KFENNELLY@GRAHAMCURTIN.COM

Net2phone, Inc  
 Counter Defendant

Date	#	Proceeding Text
06/01/2006	1	COMPLAINT against EBAY, INC., SKYPE TECHNOLOGIES SA, SKYPE, INC., JOHN DOES 1-10 ( Filing fee \$ 350 receipt number 987250.) JURY DEMAND, filed by NET2PHONE, INC.. (Attachments: # 1 Exhibit A# 2 7.1) (lm2, ) (Entered: 06/02/2006)
06/02/2006	--	Summons Issued as to SKYPE TECHNOLOGIES SA, SKYPE, INC..Days Due - 20. (counsel picked up 6/2/06) (lm2, ) (Entered: 06/02/2006)
06/02/2006	--	Summons Issued as to EBAY, INC..Days Due - 20. (counsel picked up 6/2/06) (lm2, ) (Entered: 06/02/2006)
06/07/2006	2	AMENDED COMPLAINT against all defendants all defendants., filed by NET2PHONE, INC..(LASALA, JOSEPH) (Entered: 06/07/2006)
06/09/2006	3	AMENDED COMPLAINT against EBAY, INC., SKYPE TECHNOLOGIES SA, SKYPE, INC., JOHN DOES 1-10, filed by NET2PHONE, INC.. (Attachments: # 1 Exhibit A to amended complaint)(LASALA, JOSEPH) (Entered: 06/09/2006)

06/21/2006	4	MOTION for Leave to Appear Pro Hac Vice of Allen Rubenstein and Steven Stern by NET2PHONE, INC.. (Attachments: # 1 Affidavit of Joseph P. LaSala# 2 Affidavit of Steven Stern# 3 Affidavit of Allen Rubenstein# 4 Text of Proposed Order # 5 Certificate of Service)(LASALA, JOSEPH) (Entered: 06/21/2006)
06/21/2006	--	Set Deadlines as to 4 MOTION for Leave to Appear Pro Hac Vice of Allen Rubenstein and Steven Stern . Motion Hearing set for 7/24/2006 10:00 AM before Judge Katharine S. Hayden. (nr, ) (PLEASE BE ADVISED THAT THIS MOTION WILL BE DECIDED ON THE PAPERS UNLESS OTHERWISE NOTIFIED BY THE COURT) (Entered: 06/22/2006)
06/26/2006	5	NOTICE of Appearance by MARIA A. SAVIO on behalf of all plaintiffs (SAVIO, MARIA) (Entered: 06/26/2006)
06/26/2006	6	ORDER granting 4 Motion for Allen I. Rubenstein & Steven Stern to Appear Pro Hac Vice . Signed by Judge S. D. Wigenton on 06/22/06. (nr, ) Modified on 6/27/2006 (nr, ). (Entered: 06/27/2006)
06/28/2006	7	AMENDED COMPLAINT against all defendants all defendants., filed by NET2PHONE, INC.. (Attachments: # 1) (LASALA, JOSEPH) (Entered: 06/28/2006)
07/11/2006	8	MOTION for Leave to Appear Pro Hac Vice by NET2PHONE, INC.. (Attachments: # 1 Affidavit of J. LaSala# 2 Affidavit of J. Alan Galbraith# 3 Affidavit of B. Sullivan# 4 Affidavit of M. Stern# 5 Text of Proposed Order # 6 Certificate of Service)(LASALA, JOSEPH) (Entered: 07/11/2006)
07/11/2006	--	Set Deadlines as to 8 MOTION for Leave to Appear Pro Hac Vice. Motion Hearing set for 9/11/2006 10:00 AM before Judge Katharine S. Hayden. (nr, ) (PLEASE BE ADVISED THAT THIS MOTION WILL BE DECIDED ON THE PAPERS UNLESS OTHERWISE NOTIFIED BY THE COURT) (Entered: 07/27/2006)
07/25/2006	9	AFFIDAVIT of Service for Summons and Second Amended Complaint served on Carla McCreight on behalf of Ebay on 7/13/06, filed by NET2PHONE, INC.. (LASALA, JOSEPH) (Entered: 07/25/2006)
07/25/2006	10	AFFIDAVIT of Service for Summons, Complaint, Exhibit and First Amended Complaint served on Skype, Inc. on 6/12/06, filed by NET2PHONE, INC.. (LASALA, JOSEPH) (Entered: 07/25/2006)
07/25/2006	11	AFFIDAVIT of Service for Summons, Complaint, Exhibit, First Amended Complaint served on Ebay on 6/12/06, filed by NET2PHONE, INC.. (LASALA, JOSEPH) (Entered: 07/25/2006)
07/25/2006	12	AFFIDAVIT of Service for Summons, Second Amended Complaint served on Carla McCreight on behalf of Skype, Inc. on 7/13/06, filed by NET2PHONE, INC.. (LASALA, JOSEPH) (Entered: 07/25/2006)
08/08/2006	13	ORDER granting 8 Motion for Brendan V. Sullivan, J. Alan Galbraith and Michael K. Stern to Appear Pro Hac Vice . Signed by Judge Patty Shwartz on 08/08/06. (nr, ) (Entered: 08/08/2006)
08/15/2006	14	ORDER directing plaintiff to move for default and default judgment by September 4, 2006. Signed by Judge Katharine S. Hayden on 8/15/06. (RG, ) (Entered: 08/16/2006)
08/17/2006	15	NOTICE of Appearance by THOMAS R. CURTIN on behalf of EBAY, INC., SKYPE, INC. (CURTIN, THOMAS) (Entered: 08/17/2006)
08/17/2006	16	STIPULATION AND ORDER extending deft's time to move or otherwise respond to second amended complt.. Signed by Judge Madeline C. Arleo on 08/14/06. (nr, ) (Entered: 08/18/2006)
09/15/2006	17	ANSWER to Amended Complaint, COUNTERCLAIM against all plaintiffs by EBAY, INC., SKYPE TECHNOLOGIES SA, SKYPE, INC.. (Attachments: # 1 Statement Rule 7.1 Disclosure Statement# 2 Certificate of Service) (FENNELLY, KATHLEEN) (Entered: 09/15/2006)
09/20/2006	18	ANSWER to Counterclaim by NET2PHONE, INC.. (Attachments: # 1)(LASALA, JOSEPH) (Entered: 09/20/2006)
09/22/2006	19	Notice of Request by Pro Hac Vice to receive Notices of Electronic Filings. (LASALA, JOSEPH) (Entered: 09/22/2006)
09/22/2006	20	Notice of Request by Pro Hac Vice to receive Notices of Electronic Filings. (LASALA, JOSEPH) (Entered: 09/22/2006)
09/22/2006	21	Notice of Request by Pro Hac Vice to receive Notices of Electronic Filings. (LASALA, JOSEPH) (Entered: 09/22/2006)
09/22/2006	22	Notice of Request by Pro Hac Vice to receive Notices of Electronic Filings. (LASALA, JOSEPH) (Entered: 09/22/2006)
09/22/2006	23	Notice of Request by Pro Hac Vice to receive Notices of Electronic Filings. (LASALA, JOSEPH) (Entered: 09/22/2006)
10/06/2006	24	ORDER granting application for pro hac vice admission of Andrei Iancu, Morgan Chu, Ted M. Sichelman and Michelle E. Armond . Signed by Judge Patty Shwartz on 10/03/06. (nr, ) (Entered: 10/10/2006)
10/11/2006	25	SCHEDULING ORDER setting Scheduling Conference for 10/27/2006 11:30 AM in Newark - Courtroom 10 before Magistrate Judge Patty Shwartz. Signed by Judge Patty Shwartz on 10/11/06. (aa, ) (Entered: 10/11/2006)
10/12/2006	--	Pro Hac Vice fee: \$ 600.00, receipt number 200341554 re Andrei Iancu, Morgan Chu, Sichel Man, Michelle Armond (nr, ) (Entered: 10/13/2006)
10/16/2006	26	Notice of Request by Pro Hac Vice Andrei Iancu, Esq. to receive Notices of Electronic Filings. (FENNELLY, KATHLEEN) (Entered: 10/16/2006)
10/16/2006	27	Notice of Request by Pro Hac Vice Morgan Chu, Esq. to receive Notices of Electronic Filings. (FENNELLY,

KATHLEEN) (Entered: 10/16/2006)

10/16/2006 28 Notice of Request by Pro Hac Vice Michelle E. Armond, Esq. to receive Notices of Electronic Filings. (FENNELLY, KATHLEEN) (Entered: 10/16/2006)

10/16/2006 29 Notice of Request by Pro Hac Vice Ted M. Sichelman, Esq. to receive Notices of Electronic Filings. (FENNELLY, KATHLEEN) (Entered: 10/16/2006)

10/27/2006 -- Minute Entry for proceedings held before Judge Patty Shwartz : Scheduling Conference held on 10/27/2006. (aa, ) (Entered: 10/30/2006)

10/30/2006 30 PRETRIAL SCHEDULING ORDER: Settlement Conference set for 4/12/2007 01:00 PM before Magistrate Judge Patty Shwartz. Telephone Conference set for 12/4/2006 04:00 PM before Magistrate Judge Patty Shwartz. Final Pretrial Conference set for 6/17/2008 01:00 PM before Magistrate Judge Patty Shwartz. Discovery due by 12/31/2007. Proposed Pretrial Order due by 6/10/2008.. Signed by Judge Patty Shwartz on 10/27/2006. (nr, ) (Entered: 10/31/2006)

11/02/2006 31 Letter from Joseph La Sala. (LASALA, JOSEPH) (Entered: 11/02/2006)

11/03/2006 32 CORRECTED SCHEDULING ORDER: Settlement Conference set for 4/12/2007 01:00 PM before Magistrate Judge Patty Shwartz. Telephone Conference set for 12/4/2006 04:00 PM before Magistrate Judge Patty Shwartz. Final Pretrial Conference set for 6/17/2008 01:00 PM before Magistrate Judge Patty Shwartz. Amended Pleadings due by 3/8/2007.. Signed by Judge Patty Shwartz on 11/2/2006. (mn, ) (Entered: 11/03/2006)

11/03/2006 33 Notice of Request by Pro Hac Vice Andrei Iancu, Esq. to receive Notices of Electronic Filings. (FENNELLY, KATHLEEN) (Entered: 11/03/2006)

11/20/2006 34 Letter from Joseph P. LaSala, Esq. enclosing Plaintiff's Preliminary Identification of Allegedly Infringing Products List and Certification of service. (LASALA, JOSEPH) (Entered: 11/20/2006)

11/30/2006 35 Letter from Joseph La Sala. (LASALA, JOSEPH) (Entered: 11/30/2006)

12/01/2006 36 Letter from Joseph La Sala. (LASALA, JOSEPH) (Entered: 12/01/2006)

12/04/2006 -- Minute Entry for proceedings held before Judge Patty Shwartz : Telephone Conference held on 12/4/2006. (aa, ) (Entered: 12/08/2006)

12/08/2006 37 Letter from Joseph La Sala. (LASALA, JOSEPH) (Entered: 12/08/2006)

12/11/2006 38 Letter from Joseph P. La Sala, Esq. in lieu of formal motion regarding form of protective order re Telephone Conference. (Attachments: # 1 Exhibit 1# 2 Exhibit 2# 3 Exhibit 3# 4 Certificate of Service)(LASALA, JOSEPH) (Entered: 12/11/2006)

01/04/2007 39 DISCOVERY CONFIDENTIALITY ORDER ON INFORMAL APPLICATION . Signed by Judge Patty Shwartz on 12/29/06. (dc, ) (Entered: 01/04/2007)

01/17/2007 40 Letter from Joseph La Sala. (LASALA, JOSEPH) (Entered: 01/17/2007)

01/17/2007 41 ORDER on informal application denying request to impose a patent prosecution bar. Signed by Judge Patty Shwartz on 1/12/2007. (mn, ) (Entered: 01/17/2007)

01/19/2007 42 ORDER ON INFORMAL APPL. that the issue raised in the 1/16/07 letter is deemed resolved by the Order dated 1/12/07.. Signed by Judge Patty Shwartz on 1/17/07. (DD, ) (Entered: 01/19/2007)

01/22/2007 43 TRANSCRIPT of Proceedings held on December 29, 2006 before Judge Shwartz. PLEASE NOTE: The complete transcript of these proceedings is maintained in paper format on file in the Clerks Office. To request copies of this transcript, contact the Official Court Reporter or Transcription Service who prepared the transcript. (ji, ) (Entered: 01/23/2007)

01/30/2007 44 ORDER on informal application mootng the need to file a response to the letter seeking reconsideration of the Discovery Confidentiality order . Signed by Judge Patty Shwartz on 01/30/2007. (nr, ) (Entered: 01/31/2007)

02/05/2007 45 NOTICE by TED M. SICHELMAN, MICHELLE E. ARMOND, EBAY, INC., EBAY, INC., SKYPE TECHNOLOGIES SA, SKYPE, INC., SKYPE TECHNOLOGIES SA, SKYPE, INC. re 24 Order NOTICE OF WITHDRAWAL OF ADMISSIONS PRO HAC VICE OF TED M. SICHELMAN, ESQ., AND MICHELLE E. ARMOND, ESQ. (FENNELLY, KATHLEEN) (Entered: 02/05/2007)

02/06/2007 46 ORDER ON INFORMAL APPLICATION granting pro hac vice admission of counsel etc. Signed by Judge Patty Shwartz on 2/6/07. (cs, ) (Entered: 02/09/2007)

02/06/2007 47 DECLARATION of Kathleen N. Fennelly, Esq.in support of pro hac vice admission on behalf of eBay, Inc and Skype, Inc. (cs, ) (Entered: 02/09/2007)

02/06/2007 48 DECLARATION of Alan J. Heinrich re admission pro hac vice on behalf of dfts., e-Bay Inc. and Skype, Inc. (cs, ) (Entered: 02/09/2007)

02/06/2007 49 DECLARATION of Eric Vandeveldre re admission pro hac vice on behalf of dfts., EBAY, INC., SKYPE, INC.. (cs, ) (Entered: 02/09/2007)

02/06/2007 50 DECLARATION of Andrew D. Weiss re admission pro hac vice on behalf of dfts., EBAY, INC., SKYPE, INC.. (cs, ) (Entered: 02/09/2007)

02/27/2007 -- Minute Entry for proceedings held before Judge Patty Shwartz : Telephone Conference held on 2/27/2007.

- (aa, ) (Entered: 03/05/2007)
- 02/28/2007 51 ORDER on informal application granting request to extend the deadline to commence foreign evidence collection and to file motions to amend the pleadings, SCHEDULING ORDER: Settlement Conference set for 4/12/2007 01:00 PM before Magistrate Judge Patty Shwartz. Telephone Conference set for 6/18/2007 03:00 PM before Magistrate Judge Patty Shwartz. Final Pretrial Conference set for 6/17/2007 01:00 PM before Magistrate Judge Patty Shwartz. Discovery due by 12/31/2007.. Signed by Judge Patty Shwartz on 02/27/2007. (nr, ) (Entered: 03/01/2007)
- 03/02/2007 -- Pro Hac Vice fee: \$ 450.00, receipt number 200344847 alan J. Heinrich, Andrew D. Weiss and Eric Vandevelde (nr, ) (Entered: 03/05/2007)
- 03/05/2007 52 ORDER on informal application granting request to extend the deadline to submit a proposed confidentiality order and clarify the timing for serving interrogatories; SCHEDULING ORDER: Settlement Conference set for 4/12/2007 01:00 PM before Magistrate Judge Patty Shwartz. Telephone Conference set for 2/27/2007 03:00 PM before Magistrate Judge Patty Shwartz. Final Pretrial Conference set for 6/17/2008 01:00 PM before Magistrate Judge Patty Shwartz. Discovery due by 12/31/2007. Proposed Pretrial Order due by 6/10/2008.. Signed by Judge Patty Shwartz on 12/04/2006. (nr, ) (Entered: 03/05/2007)
- 03/08/2007 53 Notice of Request by Pro Hac Vice Alan J. Heinrich to receive Notices of Electronic Filings. (FENNELLY, KATHLEEN) (Entered: 03/08/2007)
- 03/08/2007 54 Notice of Request by Pro Hac Vice Andrew D. Weiss to receive Notices of Electronic Filings. (FENNELLY, KATHLEEN) (Entered: 03/08/2007)
- 03/08/2007 55 Notice of Request by Pro Hac Vice Eric Vandevelde to receive Notices of Electronic Filings. (FENNELLY, KATHLEEN) (Entered: 03/08/2007)
- 03/14/2007 56 ORDER on Informal application that depts' request to bar Professor Bhattacharjee from being designated as an expert witness in this case is denied w/out prejudice, etc.. Signed by Judge Patty Shwartz on 3/14/07. (jd, ) (Entered: 03/14/2007)
- 03/26/2007 57 SCHEDULING LETTER ORDER: Settlement Conference set for 6/18/2007 10:00 AM before Magistrate Judge Patty Shwartz.. Signed by Judge Patty Shwartz on 03/26/2007. (nr, ) (Entered: 03/27/2007)
- 03/28/2007 58 Letter from Thomas R. Curtin, Esq.. (CURTIN, THOMAS) (Entered: 03/28/2007)
- 03/29/2007 59 ORDER denying pltf's request to extend certain deadlines. Signed by Judge Patty Shwartz on 03/29/2007. (nr, ) (Entered: 03/30/2007)
- 03/30/2007 60 NOTICE by NET2PHONE, INC. of Claims Identification (Attachments: # 1)(LASALA, JOSEPH) (Entered: 03/30/2007)
- 04/10/2007 61 Order on informal application granting request to extend pretrial deadlines; & THIRD AMENDED SCHEDULING ORDER: Settlement Conference set for 6/18/2007 10:00 AM before Magistrate Judge Patty Shwartz., Telephone Conference set for 9/25/2007 03:00 PM before Magistrate Judge Patty Shwartz., Final Pretrial Conference set for 6/17/2007 01:00 PM before Magistrate Judge Patty Shwartz.,Discovery due by 12/31/2007.. Signed by Judge Patty Shwartz on 04/09/2007. (nr, ) (Entered: 04/11/2007)
- 04/13/2007 62 MOTION for Leave to Appear Pro Hac Vice on Behalf of Bruce R. Genderson, Esq., Nicholas J. Boyle, Esq., Kevin Hardy, Esq. and Hannah M. Stott-Bumsted, Esq. by NET2PHONE, INC.. (Attachments: # 1 Affidavit of Joseph P. La Sala, Esq.# 2 Affidavit of Kevin Hardy, Esq.# 3 Affidavit of Nicholas J. Boyle, Esq.# 4 Affidavit of Hannah M. Stott-Bumsted, Esq.# 5 Affidavit of Bruce R. Genderson, Esq.# 6 Text of Proposed Order # 7 Certificate of Service)(LASALA, JOSEPH) (Entered: 04/13/2007)
- 04/13/2007 63 ORDER on informal application granting the parties request to extend deadline to raise disputes regarding the designation of Dr. Bhattacharjee as an expert. Signed by Judge Patty Shwartz on 04/12/2007. (nr, ) (Entered: 04/16/2007)
- 04/16/2007 64 ORDER granting 62 Motion for Bruce R. Genderson, Nicholas J. Boyle, Kevin Hardy, and Hannah M. Stott-Bumsted to Appear Pro Hac Vice. Signed by Judge Patty Shwartz on 04/16/2007. (nr, ) (Entered: 04/17/2007)
- 04/18/2007 65 Notice of Request by Pro Hac Vice Kevin Hardy, Esq. to receive Notices of Electronic Filings. (LASALA, JOSEPH) (Entered: 04/18/2007)
- 04/18/2007 66 Notice of Request by Pro Hac Vice Hannah M. Stott-Bumsted, Esq. to receive Notices of Electronic Filings. (LASALA, JOSEPH) (Entered: 04/18/2007)
- 04/18/2007 67 Notice of Request by Pro Hac Vice Nicholas J. Boyle, Esq. to receive Notices of Electronic Filings. (LASALA, JOSEPH) (Entered: 04/18/2007)
- 04/18/2007 68 Notice of Request by Pro Hac Vice Bruce Genderson, Esq. to receive Notices of Electronic Filings. (LASALA, JOSEPH) (Entered: 04/18/2007)
- 04/19/2007 -- Pro Hac Vice fee: \$ 600.00, receipt number 1441831,1441843,1441852,1441856 re Kevin Hardy, Hannah M. Scott Brumsted, Nicholas J. Boyle, Bruce Genderson (nr, ) (Entered: 04/19/2007)
- 04/20/2007 69 MOTION to Withdraw Pro Hac Vice Admission of Michael K. Stern, Esq. by NET2PHONE, INC.. (LASALA, JOSEPH) (Entered: 04/20/2007)
- 04/20/2007 70 First MOTION for Issuance of Letters Rogatory by NET2PHONE, INC.. (Attachments: # 1 Exhibit A - Part 1# 2 Exhibit A - Part 2# 3 Exhibit B - Part 1# 4 Exhibit B - Part 2# 5 Exhibit C - Part 1# 6 Exhibit C - Part 2# 7

Exhibit D - Part 1# 8 Exhibit D - Part 2# 9 Exhibit E - Part 1# 10 Exhibit E - Part 2# 11 Exhibit F - Part 1# 12 Exhibit F - Part 2# 13 Text of Proposed Order # 14 Certificate of Service)(LASALA, JOSEPH) (Entered: 04/20/2007)

04/20/2007 -- Set Deadlines as to 70 First MOTION for Issuance of Letters Rogatory. Motion Hearing set for 5/28/2007 10:00 AM before Judge Katharine S. Hayden. (nr, ) (PLEASE BE ADVISED THAT THIS MOTION WILL BE DECIDED ON THE PAPERS UNLESS OTHERWISE NOTIFIED BY THE COURT) (Entered: 04/24/2007)

04/24/2007 -- Pro Hac Vice fee: \$ 600, receipt number 200344948 re Bruce R. Genderson, Nicholas J. Boyle, Hannah M. Stott-Bumsted, Kevin Hardy (nr, ) (Entered: 04/24/2007)

04/27/2007 71 Letter from Joseph La Sala re 70 First MOTION for Issuance of Letters Rogatory. (LASALA, JOSEPH) (Entered: 04/27/2007)

04/27/2007 72 Amended MOTION for Issuance of Letters Rogatory by NET2PHONE, INC.. (Attachments: # 1 Exhibit A - part 1# 2 Exhibit A - part 2# 3 Exhibit B# 4 Exhibit C# 5 Exhibit D# 6 Exhibit E# 7 Exhibit F# 8 Text of Proposed Order # 9 Certificate of Service)(LASALA, JOSEPH) (Entered: 04/27/2007)

04/27/2007 -- Set Deadlines as to 72 Amended MOTION for Issuance of Letters Rogatory. Motion Hearing set for 5/28/2007 10:00 AM before Judge Katharine S. Hayden. (nr, ) (PLEASE BE ADVISED THAT THIS MOTION WILL BE DECIDED ON THE PAPERS UNLESS OTHERWISE NOTIFIED BY THE COURT) (Entered: 04/30/2007)

04/30/2007 73 NOTICE by NET2PHONE, INC. of Amended Identification of Infringing Products (Attachments: # 1)(LASALA, JOSEPH) (Entered: 04/30/2007)

05/01/2007 75 ORDER withdrawing plt's request for issuance of letters rogatory (Docket No. 71). Signed by Judge Patty Shwartz on 04/27/2007. (nr, ) (Entered: 05/02/2007)

05/02/2007 74 Notice of Request by Pro Hac Vice Steven Stern, Esq. to receive Notices of Electronic Filings. (LASALA, JOSEPH) (Entered: 05/02/2007)

05/07/2007 76 ORDER overruling dfts' objection to the production of responsive discovery based upon a parivate agreement that contains a confidentiality clause. Any and all such responsive information shall be produced no later than 5/26/07 subject to the Discovery Confidentiality Order. Signed by Judge Patty Shwartz on 5/7/07. (cs, ) (Entered: 05/07/2007)

05/07/2007 77 MOTION for Leave to File Third Amended Cmplaint by NET2PHONE, INC.. (Attachments: # 1 Exhibit 1-Third Amended Complaint# 2 Text of Proposed Order # 3 Certificate of Service)(LASALA, JOSEPH) (Entered: 05/07/2007)

05/07/2007 78 ORDER granting 72 Motion for Issuance of Letters Rogatory. Signed by Judge Patty Shwartz on 05/07/20047. (nr, ) (Entered: 05/09/2007)

05/07/2007 -- Set Deadlines as to 77 MOTION for Leave to File Third Amended Complaint . Motion Hearing set for 6/11/2007 10:00 AM before Judge Katharine S. Hayden. (nr, ) (PLEASE BE ADVISED THAT THIS MOTION WILL BE DECIDED ON THE PAPERS UNLESS OTHERWISE NOTIFIED BY THE COURT) (Entered: 05/09/2007)

05/07/2007 -- Minute Entry for proceedings held before Judge Patty Shwartz : Telephone Conference held on 5/7/2007. (aa, ) (Entered: 06/01/2007)

05/11/2007 79 Third MOTION for Issuance of Letters Rogatory by NET2PHONE, INC.. (Attachments: # 1 Exhibit A# 2 Exhibit B# 3 Exhibit C# 4 Exhibit D# 5 Exhibit E# 6 Exhibit F# 7 Text of Proposed Order # 8 Certificate of Service) (LASALA, JOSEPH) (Entered: 05/11/2007)

05/11/2007 -- Set Deadlines as to 79 Third MOTION for Issuance of Letters Rogatory. Motion Hearing set for 6/11/2007 10:00 AM before Judge Katharine S. Hayden. (nr, ) (PLEASE BE ADVISED THAT THIS MOTION WILL BE DECIDED ON THE PAPERS UNLESS OTHERWISE NOTIFIED BY THE COURT) (Entered: 05/15/2007)

05/14/2007 80 TRANSCRIPT of Proceedings held on May 7, 2007 before Judge Shwartz. PLEASE NOTE: The complete transcript of these proceedings is maintained in paper format on file in the Clerks Office. To request copies of this transcript, contact the Official Court Reporter or Transcription Service who prepared the transcript. (jl, ) (Entered: 05/15/2007)

05/21/2007 81 ORDER granting 79 Motion for Issuance of Letters Rogatory. Signed by Judge Patty Shwartz on 05/18/2007. (nr, ) (Entered: 05/21/2007)

05/22/2007 -- Letters Rogatory issued re 81 Order on Motion for Issuance of Letters Rogatory. (mn, ) (Entered: 05/22/2007)

05/29/2007 82 Letter from Thomas R. Curtin, Esq., re 77 MOTION for Leave to File Third Amended Complaint . (CURTIN, THOMAS) (Entered: 05/29/2007)

05/30/2007 83 MOTION for Leave to Appear Pro Hac Vice on behalf of Michael D. Hurwitz, Esq. by NET2PHONE, INC.. (Attachments: # 1 Affidavit of Josphe P. La Sala# 2 Affidavit of Michael D. Hurwitz# 3 Text of Proposed Order # 4 Certificate of Service)(LASALA, JOSEPH) (Entered: 05/30/2007)

05/30/2007 85 ORDER on informal application granting the request to extend deadlines concerning the invalidity disclosures and infringement contentions to address the newly asserted patent; FOURTH AMENDED PRETRIAL SCHEDULING ORDER: Settlement Conference set for 6/18/2007 10:00 PM before Magistrate Judge Patty Shwartz., Telephone Conference set for 9/25/2007 03:00 PM before Magistrate Judge Patty Shwartz., Final Pretrial Conference set for 6/17/2008 01:00 PM before Magistrate Judge Patty Shwartz..Discovery due by 12/31/2007.. Signed by Judge Patty Shwartz on 05/30/2007. (nr, ) (Entered: 05/31/2007)



- 05/30/2007 -- Set Deadlines as to 83 MOTION for Leave to Appear Pro Hac Vice on behalf of Michael D. Hurwitz, Esq. . Motion Hearing set for 6/25/2007 10:00 AM before Judge Katharine S. Hayden. (nr, ) (PLEASE BE ADVISED THAT THIS MOTION WILL BE DECIDED ON THE PAPERS UNLESS OTHERWISE NOTIFIED BY THE COURT) (Entered: 05/31/2007)
- 05/31/2007 84 NOTICE by NET2PHONE, INC. of Withdrawal of Admission Pro Hac Vice of J. Alan Galbraith, Esq. (LASALA, JOSEPH) (Entered: 05/31/2007)
- 05/31/2007 86 ORDER granting 77 Motion for Leave to File third amended complt.. Signed by Judge Patty Shwartz on 05/30/2007. (nr, ) (Entered: 05/31/2007)
- 05/31/2007 87 ORDER granting 83 Motion for Michael D. Hurwitz to Appear Pro Hac Vice. Signed by Judge Patty Shwartz on 05/31/2007. (nr, ) (Entered: 06/01/2007)
- 06/04/2007 88 AMENDED COMPLAINT against all defendants all defendants., filed by NET2PHONE, INC.. (Attachments: # 1) (LASALA, JOSEPH) (Entered: 06/04/2007)
- 06/12/2007 89 Notice of Request by Pro Hac Vice Michael D. Hurwitz, Esq. to receive Notices of Electronic Filings. (LASALA, JOSEPH) (Entered: 06/12/2007)
- 06/12/2007 -- Pro Hac Vice fee: \$ 150, receipt number 200345674 re Michael Hurwitz (nr, ) (Entered: 06/12/2007)
- 06/22/2007 90 LETTER ORDER: resetting Settlement Conference set for 9/6/2007 11:00 AM before Magistrate Judge Patty Shwartz.. Signed by Judge Patty Shwartz on 06/22/2007. (nr, ) (Entered: 06/25/2007)
- 06/25/2007 91 ANSWER to Amended Complaint, COUNTERCLAIM against all plaintiffs by EBAY, INC., SKYPE TECHNOLOGIES SA, SKYPE, INC.. (Attachments: # 1 Certificate of Service)(CURTIN, THOMAS) (Entered: 06/25/2007)
- 06/25/2007 92 Letter from Joseph P. La Sala, Esq. Regarding Joint Request to Change Scheduling Order. (LASALA, JOSEPH) (Entered: 06/25/2007)
- 06/25/2007 93 CONSENT ORDER extending defts' time to answer to 06/25/2007. Signed by Judge Patty Shwartz on 06/22/2007. (nr, ) (Entered: 06/26/2007)
- 06/25/2007 94 ORDER on informal application granting request to extend deadline to raise unresolved discovery, FIFTH AMENDED PRETRIAL SCHEDULING ORDER: Settlement Conference set for 9/6/2007 11:30 AM before Magistrate Judge Patty Shwartz., Telephone Conference set for 9/25/2007 03:00 PM, 12/4/2007 AT 3:00P.M. & 4/29/2008 AT 3:00P.M. before Magistrate Judge Patty Shwartz., Final Pretrial Conference set for 6/17/2008 01:00 PM before Magistrate Judge Patty Shwartz.,Discovery due by 12/31/2007.. Signed by Judge Patty Shwartz on 06/24/2007. (nr, ) (Entered: 06/26/2007)
- 06/27/2007 95 LETTER ORDER: Settlement Conference set for 9/6/2007 11:00 AM before Magistrate Judge Patty Shwartz.. Signed by Judge Patty Shwartz on 06/26/2007. (nr, ) (Entered: 06/27/2007)
- 08/06/2007 96 ORDER on informal application granting the request to extend deadline to submit Markman briefs; SCHEDULING ORDER: Settlement Conference set for 9/6/2007 11:30 AM before Magistrate Judge Patty Shwartz., Telephone Conference set for 9/25/2007 03:00 PM before Magistrate Judge Patty Shwartz., Final Pretrial Conference set for 6/17/2007 01:00 PM before Magistrate Judge Patty Shwartz.,Discovery due by 12/31/2007.. Signed by Judge Patty Shwartz on 08/06/2007. (nr, ) (Entered: 08/07/2007)
- 08/30/2007 97 Platiniff's Net2Phone, Inc's Opening Claim Construction MEMORANDUM by NET2PHONE, INC.. (Attachments: # 1 Declaration of Kevin Hardy# 2 Exhibit 1# 3 Exhibit 2# 4 Exhibit 3# 5 Exhibit 4# 6 Exhibit 5# 7 Exhibit 6# 8 Exhibit 7# 9 Exhibit 8# 10 Exhibit 9# 11 Exhibit 10# 12 Exhibit 11# 13 Exhibit 12# 14 Exhibit 13# 15 Exhibit 14# 16 Exhibit 15# 17 Exhibit 16# 18 Exhibit 17# 19 Certificate of Service)(LASALA, JOSEPH) Modified on 10/11/2007 (rg, ). (Entered: 08/30/2007)
- 08/30/2007 98 Declaration of Alan J. Heinrich in support of Opening Claim Construction MEMORANDUM of SKYBE Tech, SKYPE, Inc. and EBAY by EBAY, INC., SKYPE TECHNOLOGIES SA, SKYPE, INC.. (Attachments: # 1 Exhibit A# 2 Exhibit B# 3 Exhibit C# 4 Exhibit D# 5 Exhibit E# 6 Exhibit F# 7 Exhibit G# 8 Exhibit H# 9 Exhibit I# 10 Exhibit J# 11 Exhibit K# 12 Exhibit L# 13 Exhibit M# 14 Exhibit N# 15 Exhibit O# 16 Exhibit P# 17 Exhibit Q# 18 Exhibit R# 19 Exhibit S# 20 Exhibit T# 21 Exhibit U# 22 Exhibit V# 23 Exhibit W# 24 Brief Skype's Opening Claim Construction Brief# 25 Appendix A# 26 Appendix B# 27 Certificate of Service)(CURTIN, THOMAS) Modified on 10/11/2007 (rg, ). (Entered: 08/30/2007)
- 09/07/2007 99 LETTER ORDER rescheduling Settlement Conference set for 10/29/2007 11:00 AM before Magistrate Judge Patty Shwartz.. Signed by Judge Patty Shwartz on 09/07/2007. (nr, ) (Entered: 09/10/2007)
- 09/11/2007 100 ORDER on informal application granting request that defts. produce hardware, compilers and codes needed to establish a "test". Signed by Judge Patty Shwartz on 09/11/2007. (nr, ) (Entered: 09/12/2007)
- 09/17/2007 101 TRANSCRIPT of Proceedings held on September 11, 2007 before Judge Shwartz. PLEASE NOTE: The complete transcript of these proceedings is maintained in paper format on file in the Clerks Office. To request copies of this transcript, contact the Official Court Reporter or Transcription Service who prepared the transcript. (ji, ) (Entered: 09/18/2007)
- 09/20/2007 102 Letter from Thomas R. Curtin, Esq.. (FENNELLY, KATHLEEN) (Entered: 09/20/2007)
- 09/21/2007 103 Letter from Joseph P. La Sala, Esq. regarding discovery disputes. (LASALA, JOSEPH) (Entered: 09/21/2007)
- 09/24/2007 -- CLERK'S QUALITY CONTROL MESSAGE: ERIC VANDEVELDE, does not have a correct e-mail address listed with the court and is not receiving his/her notices of electronic filing in this case. Pursuant to local rule 10.1 and court procedures, counsel and unrepresented parties are required to notify the court of any mailing or e-mail

address changes. The court has deleted the invalid e-mail address. Attorneys should review the ECF link on our web site for information on maintaining your account and unrepresented parties, or those attorneys without access to maintaining their account, should notice the Clerk. (mem, ) (Entered: 09/24/2007)

- 09/25/2007 -- Text Minute Entry for proceedings held before Judge Patty Shwartz : Telephone Conference held on 9/25/2007. (aa, ) (Entered: 09/28/2007)
- 09/27/2007 104 ORDER on informal application directing the pltf. to submit no later than Oct. 15, 2007 the nonprivileged documents referred to in the Sept. 20, 2007 submissions. Signed by Judge Patty Shwartz on 09/25/2007. (nr, ) (Entered: 09/28/2007)
- 10/02/2007 105 NOTICE by ERIC VANDELDE, EBAY, INC., SKYPE TECHNOLOGIES SA, SKYPE, INC. re 55 Notice of Pro Hac Vice to Receive NEF Withdrawal of Pro Hac Vice Admission and Request for Electronic Notification (FENNELLY, KATHLEEN) (Entered: 10/02/2007)
- 10/04/2007 106 Plaintiff Net2Phone Inc's Response MEMORANDUM on Claim Construction by NET2PHONE, INC.. (Attachments: # 1 Declaration of Kevin Hard (Second)# 2 Exhibit 18# 3 Exhibit 19# 4 Exhibit 20# 5 Exhibit 21# 6 Exhibit 22# 7 Exhibit 23# 8 Exhibit 24# 9 Exhibit 25# 10 Exhibit 26# 11 Exhibit 27# 12 Exhibit 28# 13 Exhibit 29# 14 Certificate of Service)(LASALA, JOSEPH) Modified on 10/11/2007 (rg, ). (Entered: 10/04/2007)
- 10/04/2007 107 Responsive claim Construction MEMORANDUM of SKYPE Tech, SKYPE and EBAY by EBAY, INC., SKYPE TECHNOLOGIES SA, SKYPE, INC.. (Attachments: # 1 Declaration of David Johnson# 2 Exhibit 1# 3 Exhibit 2# 4 Declaration of Alan Heinrich# 5 Exhibit A# 6 Exhibit A part 2# 7 Exhibit B# 8 Exhibit C# 9 Exhibit D# 10 Exhibit E# 11 Exhibit F# 12 Certificate of Service)(CURTIN, THOMAS) Modified on 10/11/2007 (rg, ). (Entered: 10/04/2007)
- 10/11/2007 108 Minute Entry for proceedings held before Judge Katharine S. Hayden : Status Conference held on 10/11/2007. (rg, ) (Entered: 10/12/2007)
- 10/11/2007 111 AMENDED Minute Entry for proceedings held before Judge Katharine S. Hayden : Status Conference held on 10/11/2007. (rg, ) Additional attachment(s) added on 10/19/2007 (rg, ). (Entered: 10/18/2007)
- 10/15/2007 109 Letter from Joseph P. La Sala, Esq.. (LASALA, JOSEPH) (Entered: 10/15/2007)
- 10/15/2007 110 ORDER on informal application directing he parties o produce the supplemental responses to the document demands to include documents that came into existence between April 1, 2007 and Aug. 1, 2007. Signed by Judge Patty Shwartz on 10/13/2007. (nr, ) (Entered: 10/16/2007)
- 10/18/2007 112 AMENDED DOCUMENT by NET2PHONE, INC.. Amendment to 97 Pretrial Memorandum, Supplemental Memorandum Relating to Entry 97 . (Attachments: # 1 Certificate of Service for Supplemental Memorandum Relating to Entry 97)(LASALA, JOSEPH) (Entered: 10/18/2007)
- 10/18/2007 113 AMENDED DOCUMENT by NET2PHONE, INC.. Amendment to 106 Pretrial Memorandum, Supplemental Memorandum Relating to Entry 106 . (Attachments: # 1 Certificate of Service for Supplemental Memorandum Relating to Entry 106)(LASALA, JOSEPH) (Entered: 10/18/2007)
- 10/18/2007 114 AMENDED DOCUMENT by EBAY, INC., SKYPE TECHNOLOGIES SA, SKYPE, INC.. Amendment to 98 Pretrial Memorandum,, Supplemental Memorandum Relating to Entry 98, Attachment 24 . (Attachments: # 1 Appendix A to Reformatted Opening Brief# 2 Appendix B to Reformatted Opening Brief# 3 Certificate of Service)(CURTIN, THOMAS) (Entered: 10/18/2007)
- 10/18/2007 115 AMENDED DOCUMENT by EBAY, INC., SKYPE TECHNOLOGIES SA, SKYPE, INC.. Amendment to 107 Pretrial Memorandum, Supplemental Memorandum Relating to Entry 107 . (Attachments: # 1 Certificate of Service) (CURTIN, THOMAS) (Entered: 10/18/2007)
- 10/19/2007 116 PRETRIAL MEMORANDUM by NET2PHONE, INC.. (Attachments: # 1 Declaration of Kevin Hardy (Third)# 2 Exhibit 30 to Third Declaration of Kevin Hardy# 3 Exhibit 31 to Third Declaration of Kevin Hardy# 4 Exhibit 32 to Third Declaration of Kevin Hardy# 5 Exhibit 33 to Third Declaration of Kevin Hardy# 6 Declaration of Professor Larry L. Peterson# 7 Exhibit 1 to Peterson Declaration# 8 Exhibit 2 to Peterson Declaration# 9 Exhibit 3 to Peterson Declaration# 10 Exhibit 4 to Peterson Declaration# 11 Exhibit 5 to Peterson Declaration# 12 Exhibit 6 to Peterson Declaration# 13 Exhibit 7 to Peterson Declaration# 14 Exhibit 8 to Peterson Declaration# 15 Exhibit 9 to Peterson Declaration# 16 Exhibit 10 to Peterson Declaration# 17 Exhibit 11 to Peterson Declaration# 18 Exhibit 12 to Peterson Declaration# 19 Exhibit 13 to Peterson Declaration# 20 Exhibit 14 to Peterson Declaration# 21 Exhibit 15 to Peterson Declaration# 22 Exhibit 16 to Peterson Declaration# 23 Exhibit 17 to Peterson Declaration# 24 Certificate of Service)(LASALA, JOSEPH) (Entered: 10/19/2007)
- 10/19/2007 117 PRETRIAL MEMORANDUM by EBAY, INC., SKYPE TECHNOLOGIES SA, SKYPE, INC.. (Attachments: # 1 Appendix to Reply Claim Construction Brief# 2 Declaration of Alan Heinrich# 3 Exhibit A to Heinrich Dec.# 4 Exhibit B to Heinrich Dec.# 5 Exhibit D to Heinrich Dec.# 6 Exhibit E to Heinrich Dec.# 7 Exhibit H to Heinrich Dec.# 8 Exhibit I to Heinrich Dec.# 9 Exhibit J to Heinrich Dec.# 10 Exhibit K to Heinrich Dec.# 11 Exhibit L to Heinrich Dec.# 12 Exhibit M to Heinrich Dec.# 13 Exhibit C to Heinrich Dec.# 14 Certificate of Service) (CURTIN, THOMAS) (Entered: 10/19/2007)
- 10/19/2007 118 PRETRIAL MEMORANDUM by EBAY, INC., SKYPE TECHNOLOGIES SA, SKYPE, INC.. (Attachments: # 1 Exhibit F# 2 Exhibit G)(FENNELLY, KATHLEEN) (Entered: 10/19/2007)
- 10/22/2007 119 MOTION to Seal by EBAY, INC., SKYPE TECHNOLOGIES SA, SKYPE, INC.. (Attachments: # 1 Brief # 2 Declaration of Kathleen N. Fennelly# 3 Text of Proposed Order # 4 Certificate of Service)(CURTIN, THOMAS) (Entered: 10/22/2007)

- 10/22/2007 -- Set Deadlines as to 119 MOTION to Seal. Motion Hearing set for 11/26/2007 10:00 AM before Judge Katharine S. Hayden. (nr, ) (PLEASE BE ADVISED THAT THIS MOTION WILL BE DECIDED ON THE PAPERS UNLESS OTHERWISE NOTIFIED BY THE COURT) (Entered: 10/23/2007)
- 10/25/2007 120 ORDER ON INFORMAL APPLICATION directing all parties to produce the supplemental responses to the document demands to include documents that came into existence between April 1, 2007 and August 1, 2007 no later than October 29, 2007, etc. Signed by Judge Patty Schwartz on 10/25/07. (aa, ) (Entered: 10/26/2007)
- 10/29/2007 -- Minute Entry for proceedings held before Judge Patty Schwartz : Settlement Conference held on 10/29/2007. (aa, ) (Entered: 11/05/2007)
- 10/30/2007 121 MOTION for Leave to Appear Pro Hac Vice by NET2PHONE, INC.. (Attachments: # 1 Affidavit Affidavit of Joseph P. La Sala# 2 Affidavit Affidavit of Scott K. Dasovich, Esq.# 3 Text of Proposed Order Proposed Form of Order Pro Hac Vice Dasovich# 4 Certificate of Service Cert of Filing and Service Dasovich)(LASALA, JOSEPH) (Entered: 10/30/2007)
- 10/30/2007 -- Set Deadlines as to 121 MOTION for Leave to Appear Pro Hac Vice. Motion Hearing set for 11/26/2007 10:00 AM before Judge Katharine S. Hayden. (nr, )(PLEASE BE ADVISED THAT THIS MOTION WILL BE DECIDED ON THE PAPERS UNLESS OTHERWISE NOTIFIED BY THE COURT) (Entered: 11/01/2007)
- 10/30/2007 122 ORDER granting in part and denying in part 119 Motion to Seal. Signed by Judge Patty Schwartz on 10/25/2007. (nr, ) (Entered: 11/02/2007)
- 11/02/2007 123 MOTION to Strike 116 Pretrial Memorandum,,,, Specifically the Declaration of Larry Peterson submitted in Support of Reply Claim Constructin Brief by EBAY, INC., SKYPE TECHNOLOGIES SA, SKYPE, INC..Responses due by 11/12/2007 (Attachments: # 1 Brief in Support of Motion to Strike# 2 Exhibit A to Brief in Support of Motion to Strike (Decl.)# 3 Exhibit 1 to Ex. A to Brief# 4 Exhibit 2 to Ex. A to Brief# 5 Exhibit 3 to Ex. A to Brief# 6 Exhibit 4 to Ex. A to Brief# 7 Exhibit 5 to Ex. A to Brief# 8 Exhibit 6 to Ex. A to Brief# 9 Exhibit 7 to Ex. A to Brief# 10 Exhibit 8 to Ex. A to Brief# 11 Exhibit 9 to Ex. A to Brief# 12 Exhibit 10 to Ex. A to Brief# 13 Exhibit 11 to Ex. A to Brief# 14 Exhibit 12 to Ex. A to Brief# 15 Text of Proposed Order # 16 Certificate of Service)(CURTIN, THOMAS) (Entered: 11/02/2007)
- 11/02/2007 124 NOTICE by NET2PHONE, INC. of Filing Redacted Documents (Attachments: # 1)(LASALA, JOSEPH) (Entered: 11/02/2007)
- 11/02/2007 -- Set Deadlines as to 123 MOTION to Strike 116 Pretrial Memorandum,,,, Specifically the Declaration of Larry Peterson submitted in Support of Reply Claim Constructin Brief MOTION to Strike 116 Pretrial Memorandum,,,, Specifically the Declaration of Larry Peterson submitted in Support of Reply Claim Constructin Brief MOTION to Strike 116 Pretrial Memorandum,,,, Specifically the Declaration of Larry Peterson submitted in Support of Reply Claim Constructin Brief MOTION to Strike 116 Pretrial Memorandum,,,, Specifically the Declaration of Larry Peterson submitted in Support of Reply Claim Constructin Brief . Motion Hearing set for 11/26/2007 10:00 AM before Judge Katharine S. Hayden. (PLEASE BE ADVISED THAT THIS MOTION WILL BE DECIDED ON THE PAPERS UNLESS OTHERWISE NOTIFIED BY THE COURT)(nr, ) (Entered: 11/05/2007)
- 11/06/2007 125 AFFIDAVIT of Joseph P. La Sala, Esq. re 121 MOTION for Leave to Appear Pro Hac Vice Amended Affidavit by NET2PHONE, INC.. (LASALA, JOSEPH) (Entered: 11/06/2007)
- 11/06/2007 126 AMENDED DOCUMENT by NET2PHONE, INC.. Amendment to 121 MOTION for Leave to Appear Pro Hac Vice Affidavit Scott K. Dasovich, Esq. . (LASALA, JOSEPH) (Entered: 11/06/2007)
- 11/07/2007 127 ORDER on informal application overruling objection to producing Niklas Zennstrom for deposition; deposition will be completed no later than 12/20/2007. Signed by Judge Patty Schwartz on 11/05/2007. (nr, ) (Entered: 11/08/2007)
- 11/09/2007 128 ORDER granting 121 Motion for Scott K. Dasovich to Appear Pro Hac Vice. Signed by Judge Patty Schwartz on 11/07/2007. (nr, ) (Entered: 11/09/2007)
- 11/13/2007 129 BRIEF in Opposition re 123 MOTION to Strike 116 Pretrial Memorandum,,,, Specifically the Declaration of Larry Peterson submitted in Support of Reply Claim Constructin Brief MOTION to Strike 116 Pretrial Memorandum,,,, Specifically the Declaration of Larry Peterson submitted in Support of Reply Claim Constructin Brief MOTION to Strike 116 Pretrial Memorandum,,,, Specifically the Declaration of Larry Peterson submitted in Support of Reply Claim Constructin Brief MOTION to Strike 116 Pretrial Memorandum,,,, Specifically the Declaration of Larry Peterson submitted in Support of Reply Claim Constructin Brief filed by NET2PHONE, INC.. (Attachments: # 1 # 2)(LASALA, JOSEPH) (Entered: 11/13/2007)
- 11/13/2007 130 Notice of Request by Pro Hac Vice Scott K. Dasovich, Esq. to receive Notices of Electronic Filings. ( Pro Hac Vice fee \$ 150 receipt number 1736940.) (LASALA, JOSEPH) (Entered: 11/13/2007)
- 11/14/2007 -- Pro Hac Vice fee: \$ 150, receipt number 1736940 re Scott K. Dasovich (nr, ) (Entered: 11/14/2007)
- 11/16/2007 131 REPLY to Response to Motion re 123 MOTION to Strike 116 Pretrial Memorandum,,,, Specifically the Declaration of Larry Peterson submitted in Support of Reply Claim Constructin Brief MOTION to Strike 116 Pretrial Memorandum,,,, Specifically the Declaration of Larry Peterson submitted in Support of Reply Claim Constructin Brief MOTION to Strike 116 Pretrial Memorandum,,,, Specifically the Declaration of Larry Peterson submitted in Support of Reply Claim Constructin Brief MOTION to Strike 116 Pretrial Memorandum,,,, Specifically the Declaration of Larry Peterson submitted in Support of Reply Claim Constructin Brief Reply Brief in Support of Motion to Strike filed by EBAY, INC., SKYPE TECHNOLOGIES SA, SKYPE, INC.. (Attachments: # 1 Certificate of Service)(CURTIN, THOMAS) (Entered: 11/16/2007)

- 11/16/2007 -- Minute Entry for proceedings held before Judge Patty Shwartz : Settlement Conference held on 11/16/2007. (drc, ) (Entered: 12/03/2007)
- 11/19/2007 132 ORDER on Informal application granting request to extend deadlines; SEVENTH AMENDED SCHEDULING ORDER: Telephone Conference set for 12/4/2007 03:00 PM before Magistrate Judge Patty Shwartz., Final Pretrial Conference set for 6/17/2008 01:00 PM before Magistrate Judge Patty Shwartz., Proposed Pretrial Order due by 6/10/2008.. Signed by Judge Patty Shwartz on 11/16/2007. (nr, ) (Entered: 11/19/2007)
- 11/19/2007 133 ORDER granting application for pro hac vice admission of Mark M. Kuo and Benjamin T. Wang for pro hac vice admission. Signed by Judge Patty Shwartz on 11/16/2007. (nr, ) (Entered: 11/19/2007)
- 11/19/2007 137 DECLARATION of Minh Z. Kuo in support of pro hac vice admission (Attachments: # 1 Decl. of Kathleen N. Fennelly# 2 Decl. of Benjamin T. Wang)(nr, ) (Entered: 11/26/2007)
- 11/20/2007 136 ORDER on informal application requesting to correct order of 11/19/2007, and SEVENTH AMENDED SCHEDULING ORDER: Telephone Conference set for 12/4/2007 03:00 PM before Magistrate Judge Patty Shwartz., Final Pretrial Conference set for 6/17/2008 01:00 PM before Magistrate Judge Patty Shwartz.. Signed by Judge Patty Shwartz on 11/20/2007. (mn, ) (Entered: 11/26/2007)
- 11/21/2007 134 Letter from Thomas R. Curtin, Esq. (CURTIN, THOMAS) (Entered: 11/21/2007)
- 11/24/2007 135 Letter from Joseph La Sala. (LASALA, JOSEPH) (Entered: 11/24/2007)
- 11/27/2007 138 MOTION for Leave to Appear Pro Hac Vice by NET2PHONE, INC.. (Attachments: # 1 Affidavit JPLS# 2 Affidavit Robert J. Shaughnessy# 3 Certificate of Service # 4 Text of Proposed Order)(LASALA, JOSEPH) (Entered: 11/27/2007)
- 11/27/2007 139 MOTION for Leave to Appear Pro Hac Vice by NET2PHONE, INC.. (Attachments: # 1 Affidavit JPLS# 2 Affidavit Thomas G. Hentoff# 3 Certificate of Service # 4 Text of Proposed Order to appear pro hac vice)(LASALA, JOSEPH) (Entered: 11/27/2007)
- 11/27/2007 140 LETTER ORDER Setting a Telephone Conference for 11/29/2007 11:00 AM before Magistrate Judge Patty Shwartz.. Signed by Judge Patty Shwartz on 11/26/07. (cs, ) (Entered: 11/28/2007)
- 11/27/2007 -- Set Deadlines as to 139 MOTION for Leave to Appear Pro Hac Vice, 138 MOTION for Leave to Appear Pro Hac Vice. Motion Hearing set for 12/24/2007 10:00 AM before Judge Katharine S. Hayden. (nr, )(PLEASE BE ADVISED THAT THIS MOTION WILL BE DECIDED ON THE PAPERS UNLESS OTHERWISE NOTIFIED BY THE COURT) (Entered: 11/29/2007)
- 11/28/2007 142 STIPULATION AND ORDER for issuance of depositions for foreign residents. Signed by Judge Patty Shwartz on 11/28/2007. (nr, ) (Entered: 11/29/2007)
- 11/28/2007 143 ORDER granting 138 Motion for Robert J. Shaughnessy and Thomas G. Hentoff to Appear Pro Hac Vice; granting 139 Motion for Leave to Appear Pro Hac Vice. Signed by Judge Patty Shwartz on 11/28/2007. (nr, ) (Entered: 11/30/2007)
- 11/29/2007 141 TRANSCRIPT of Proceedings held on October 25, 2007 before Judge Shwartz. PLEASE NOTE: The complete transcript of these proceedings is maintained in paper format on file in the Clerks Office. To request copies of this transcript, contact the Official Court Reporter or Transcription Service who prepared the transcript. (ji, ) (Entered: 11/29/2007)
- 11/29/2007 -- Minute Entry for proceedings held before Judge Patty Shwartz : Telephone Status Conference held on 11/29/2007. (drc, ) (Entered: 12/03/2007)
- 11/30/2007 144 NOTICE by NET2PHONE, INC. of Withdrawal of Admission Pro Hac Vice of Michael D. Hurwitz, Esq. (Attachments: # 1 Certificate of Service)(LASALA, JOSEPH) (Entered: 11/30/2007)
- 11/30/2007 145 ORDER on informal application directing the pltf. to report to the Court its position concerning whether or not it would agree to have a special Master review all privilege documents and limit any appeal to legal decisions made concerning the pre-sale documents and limit such appeal to one level of appeal or agreed to have a judicial officer review only a limited sampling of the documents and to waive any appeal of the decisions about the rulings, etc.. Signed by Judge Patty Shwartz on 11/29/2007. (nr, ) (Entered: 11/30/2007)
- 12/10/2007 146 ORDER appointing Ronald J. Hedges as the special master; scheduling a telephone conference with the Special Master for 1/8/2008 at 1:00p.m.; Hearing set for 1/10/2008 10:00 AM & 1/15/2008 at 10:00a.m. before Magistrate Judge Patty Shwartz.. Signed by Judge Patty Shwartz on 12/07/2007. (nr, ) (Entered: 12/10/2007)
- 12/10/2007 147 MOTION for Leave to Appear Pro Hac Vice on behalf of Steven R. Ruby, Esq. by NET2PHONE, INC.. (Attachments: # 1 Affidavit of Joseph P. La Sala in support of motion# 2 Affidavit of Steven R. Ruby, Esq.# 3 Text of Proposed Order # 4 Certification of Service)(LASALA, JOSEPH) (Entered: 12/10/2007)
- 12/10/2007 148 Notice of Request by Pro Hac Vice Robert J. Shaughnessy, Esq. to receive Notices of Electronic Filings. ( Pro Hac Vice fee \$ 150 receipt number 1773820.) (LASALA, JOSEPH) (Entered: 12/10/2007)
- 12/10/2007 149 Letter from Thomas R. Curtin, Esq.. (CURTIN, THOMAS) (Entered: 12/10/2007)
- 12/10/2007 -- Set Deadlines as to 147 MOTION for Leave to Appear Pro Hac Vice on behalf of Steven R. Ruby, Esq. . Motion Hearing set for 1/14/2008 10:00 AM before Judge Katharine S. Hayden. (nr, ) (PLEASE BE ADVISED THAT THIS MOTION WILL BE DECIDED ON THE PAPERS UNLESS OTHERWISE NOTIFIED BY THE COURT) (Entered: 12/11/2007)
- 12/11/2007 150 Notice of Request by Pro Hac Vice Thomas G. Hentoff, Esq. to receive Notices of Electronic Filings. ( Pro Hac

Vice fee \$ 150 receipt number 1776164.) (LASALA, JOSEPH) (Entered: 12/11/2007)

12/12/2007 151 ORDER granting 147 Motion for Steven R. Ruby to Appear Pro Hac Vice. Signed by Judge Patty Shwartz on 12/11/2007. (nr, ) (Entered: 12/12/2007)

12/17/2007 152 MOTION for Leave to Appear Pro Hac Vice by NET2PHONE, INC.. (Attachments: # 1 Affidavit # 2 Affidavit # 3 Certificate of Service # 4)(LASALA, JOSEPH) (Entered: 12/17/2007)

12/17/2007 -- Set Deadlines as to 152 MOTION for Leave to Appear Pro Hac Vice. Motion Hearing set for 1/14/2008 10:00 AM before Judge Katharine S. Hayden. (nr, ) (PLEASE BE ADVISED THAT THIS MOTION WILL BE DECIDED ON THE PAPERS UNLESS OTHERWISE NOTIFIED BY THE COURT) (Entered: 12/18/2007)

12/18/2007 153 ORDER granting 152 Motion for Stephen D. Andrews to Appear Pro Hac Vice. Signed by Judge Patty Shwartz on 12/18/2007. (nr, ) (Entered: 12/19/2007)

12/19/2007 -- Pro Hac Vice fee: \$ 300.00, receipt number 200349723 re Marko Kuo & Benjamin Wang (nr, ) (Entered: 12/19/2007)

12/19/2007 154 AFFIDAVIT of Ronald J. Hedges by RONALD J. HEDGES. (HEDGES, RONALD) (Entered: 12/19/2007)

12/19/2007 155 Letter from Thomas R. Curtin, Esq., to Hon. Ronald Hedges forwarding Skype Privilege Log Submission. (FENNELLY, KATHLEEN) (Entered: 12/19/2007)

12/20/2007 156 Notice of Request by Pro Hac Vice Marko Kuo to receive Notices of Electronic Filings. (FENNELLY, KATHLEEN) (Entered: 12/20/2007)

12/20/2007 157 Notice of Request by Pro Hac Vice Benjamin Wang to receive Notices of Electronic Filings. (FENNELLY, KATHLEEN) (Entered: 12/20/2007)

01/04/2008 158 ORDER on informal application granting Skype's request for deposition of Mr. Oberg. Signed by Judge Patty Shwartz on 01/02/2008. (nr, ) (Entered: 01/07/2008)

01/10/2008 159 ORDER granting application for pro hac vice admission of Perry M. Goldberg. Signed by Judge Patty Shwartz on 01/07/2008. (nr, ) (Entered: 01/10/2008)

01/11/2008 160 Notice of Request by Pro Hac Vice Steven R. Ruby, Esq. to receive Notices of Electronic Filings. ( Pro Hac Vice fee \$ 150 receipt number 1813268.) (LASALA, JOSEPH) (Entered: 01/11/2008)

01/11/2008 161 MOTION for Leave to Appear Pro Hac Vice on Behalf of Amy Mason Saharia, Esq. by NET2PHONE, INC.. (Attachments: # 1 Affidavit # 2 Affidavit of Amy Saharia # 3 Text of Proposed Order # 4 Certificate of Service) (LASALA, JOSEPH) (Entered: 01/11/2008)

01/11/2008 -- Set Deadlines as to 161 MOTION for Leave to Appear Pro Hac Vice on Behalf of Amy Mason Saharia, Esq.. Motion Hearing set for 2/4/2008 10:00 AM before Judge Katharine S. Hayden. (nr, ) (PLEASE BE ADVISED THAT THIS MOTION WILL BE DECIDED ON THE PAPERS UNLESS OTHERWISE NOTIFIED BY THE COURT) (Entered: 01/14/2008)

01/14/2008 162 TRANSCRIPT of Proceedings held on January 2, 2008 before Judge Shwartz. PLEASE NOTE: The complete transcript of these proceedings is maintained in paper format on file in the Clerks Office. To request copies of this transcript, contact the Official Court Reporter or Transcription Service who prepared the transcript. (jl, ) (Entered: 01/14/2008)

01/14/2008 163 ORDER on informal application withdrawing the telephone conference schedule for 1/11/2008. Signed by Judge Patty Shwartz on 01/14/2008. (nr, ) (Entered: 01/14/2008)

01/14/2008 164 STATEMENT Attaching Revised Net2Phone and IDT Privilege Log by NET2PHONE, INC.. (Attachments: # 1 Exhibit A)(LASALA, JOSEPH) (Entered: 01/14/2008)

01/17/2008 165 DECLARATION of PERRY M. GOLDBERG in support of application for pro hac vice admission (nr, ) (Entered: 01/18/2008)

01/17/2008 166 DECLARATION of Kathleen N. Fennelly in support of application for pro hac vice admission (nr, ) (Entered: 01/18/2008)

01/18/2008 167 ORDER on informal application granting application for pro hac vice admission of Perry M. Goldberg. Signed by Judge Patty Shwartz on 01/07/2008. (nr, ) (Entered: 01/18/2008)

01/18/2008 168 AFFIDAVIT of Joseph P. La Sala in Compliance with Court Order by NET2PHONE, INC.. (Attachments: # 1 Certificate of Service)(LASALA, JOSEPH) (Entered: 01/18/2008)

01/22/2008 169 ORDER granting 161 Motion for Amy Mason Sharia to Appear Pro Hac Vice. Signed by Judge Patty Shwartz on 01/18/2008. (nr, ) (Entered: 01/23/2008)

01/22/2008 170 ORDER on informal application advising the parties that if they do not resolve the prior art issue by 1/24/2008 at 5:00p.m. the parties shall then submit their positions concerning the prior art issue via joint letter protocol and be prepared to discuss the issue during the the telephone conference schedule for 1/25/2008 at 5:00p.m.. Signed by Judge Patty Shwartz on 01/18/2008. (nr, ) (Entered: 01/23/2008)

01/24/2008 171 AFFIDAVIT of of Compliance by Andrew D. Weiss by EBAY, INC., SKYPE TECHNOLOGIES SA, SKYPE, INC.. (FENNELLY, KATHLEEN) (Entered: 01/24/2008)

01/24/2008 172 Letter from Thomas R. Curtin, Esq. re: Certifications of Compliance. (CURTIN, THOMAS) (Entered: 01/24/2008)

- 01/24/2008 173 Letter from Kathleen N. Fennelly, Esq., Requesting Extension of Joint Letter Deadline. (FENNELLY, KATHLEEN) (Entered: 01/24/2008)
- 01/28/2008 174 ORDER on informal application regarding production of documents and directing that depositions be completed before the close of fact discovery, etc.. Signed by Magistrate Judge Patty Shwartz on 01/25/2008. (nr, ) (Entered: 01/29/2008)
- 01/30/2008 175 Notice of Request by Pro Hac Vice Amy Mason Saharia, Esq. referred to in the Order Granting Pro Hac Vice as Amy Mason Sharia to receive Notices of Electronic Filings. ( Pro Hac Vice fee \$ 150 receipt number 0312000000001840295.) (LASALA, JOSEPH) (Entered: 01/30/2008)
- 01/30/2008 176 MOTION for Reconsideration re 174 Order on Oral Motion by NET2PHONE, INC.. (Attachments: # 1 Brief, # 2 Certification of Counsel, # 3 Exhibit A, B & C, # 4 Exhibit D, E & F, # 5 Exhibit G, H & I, # 6 Text of Proposed Order, # 7 Certificate of Service)(LASALA, JOSEPH) (Entered: 01/30/2008) ^
- 01/30/2008 --- Pro Hac Vice fee: \$ 150, receipt number 1840295 re Amy Mason Sharia (nr, ) (Entered: 01/31/2008)
- 01/30/2008 -- Set Deadlines as to 176 MOTION for Reconsideration re 174 Order on Oral Motion MOTION for Reconsideration re 174 Order on Oral Motion. Motion Hearing set for 3/3/2008 10:00 AM before Judge Katharine S. Hayden. (nr, ) (PLEASE BE ADVISED THAT THIS MOTION SHALL BE DECIDED ON THE PAPER UNLESS OTHERWISE NOTIFIED BY THE COURT) (Entered: 02/01/2008)
- 02/01/2008 178 ORDER On Informal Application for the deposition of Mr. Cohen to be completed no later than 3/14/08 in either N.J. or California; deposition of the other Vocal Tech shall take place on 2/6/08 and for the resumed deposition of Mr. Oberg shall take place in London during the week of 2/4/08 etc.. Signed by Magistrate Judge Patty Shwartz on 1/31/08(cs, ) (Entered: 02/04/2008)
- 02/01/2008 -- Minute Entry for proceedings held before Magistrate Judge Patty Shwartz: Telephone Conference held on 2/1/2008. (aa, ) (Entered: 02/25/2008)
- 02/04/2008 177 MOTION to Quash Subpoena by HOWARD S. JONAS. (Attachments: # 1 Brief, # 2 Certification of Counsel with Exhibits, # 3 Text of Proposed Order, # 4 Certificate of Service)(LASALA, JOSEPH) (Entered: 02/04/2008)
- 02/04/2008 179 TRANSCRIPT of Proceedings held on September 25, 2007 and January 25, 2008 before Judge Shwartz. PLEASE NOTE: The complete transcript of these proceedings is maintained in paper format on file in the Clerks Office. To request copies of this transcript, contact the Official Court Reporter or Transcription Service who prepared the transcript. (ji, ) (Entered: 02/05/2008)
- 02/04/2008 -- Set Deadlines as to 177 MOTION to Quash Subpoena . Motion Hearing set for 3/3/2008 10:00 AM before Judge Katharine S. Hayden. (PLEASE BE ADVISED THAT THIS MOTION WILL BE DECIDED ON THE PAPERS UNLESS OTHERWISE NOTIFIED BY THE COURT)(nr, ) (Entered: 02/07/2008)
- 02/05/2008 180 STIPULATION (JOINT) TO RESCHEDULE NET2PHONE'S DEPOSITION OF MR. LIOR HARAMATY AND PROPOSED ORDER by NET2PHONE, INC., EBAY, INC., SKYPE TECHNOLOGIES SA, SKYPE, INC.. (Attachments: # 1 Text of Proposed Order)(FENNELLY, KATHLEEN) (Entered: 02/05/2008)
- 02/08/2008 181 Letter from Kathleen N. Fennelly, Esq., Requesting Extension of Time to Oppose Motion to Quash Jonas Subpoena re 177 MOTION to Quash Subpoena . (FENNELLY, KATHLEEN) (Entered: 02/08/2008)
- 02/08/2008 182 STIPULATION Joint Stipulation re: Notice of Deposition of M. Whitman & H. Jonas by NET2PHONE, INC.. (Attachments: # 1 Text of Proposed Order)(LASALA, JOSEPH) (Entered: 02/08/2008)
- 02/08/2008 184 LETTER ORDER granting Skype's request to extend the deadline to oppose pltf's motion to quash to 2/13/2008. Signed by Magistrate Judge Patty Shwartz on 02/08/2008. (nr, ) (Entered: 02/13/2008)
- 02/08/2008 185 ORDER rescheduling Mr. Haramaty's deposition from Feb. 6, 2008 to March 6, 2008. Signed by Magistrate Judge Patty Shwartz on 02/05/2008. (nr, ) (Entered: 02/13/2008)
- 02/11/2008 183 BRIEF in Opposition re 176 MOTION for Reconsideration re 174 Order on Oral Motion MOTION for Reconsideration re 174 Order on Oral Motion filed by EBAY, INC., SKYPE TECHNOLOGIES SA, SKYPE, INC.. (Attachments: # 1 Declaration of Benjamin T. Wang in Support of Opposition to Motion for Reconsideration, # 2 Certificate of Service)(CURTIN, THOMAS) (Entered: 02/11/2008)
- 02/14/2008 189 ORDER denying 176 Motion for Reconsideration. Signed by Magistrate Judge Patty Shwartz on 02/14/2008. (nr, ) Modified on 2/15/2008 (nr, ). (Entered: 02/15/2008)
- 02/15/2008 187 MOTION to Seal by EBAY, INC., SKYPE TECHNOLOGIES SA, SKYPE, INC.. (Attachments: # 1 Brief In Support of Motion to Seal, # 2 Text of Proposed Order to Seal, # 3 Declaration of Kathleen N. Fennelly in Support of Motion to Seal, # 4 Certificate of Service)(FENNELLY, KATHLEEN) (Entered: 02/15/2008)
- 02/15/2008 188 Letter from Kathleen N. Fennelly. (CURTIN, THOMAS) (Entered: 02/15/2008)
- 02/15/2008 190 ORDER terminating/deleting document No. 186 from this docket; terminating 187 Motion to Seal. Signed by Judge Katharine S. Hayden on 02/15/2008. (nr, ) (Entered: 02/15/2008)
- 02/15/2008 191 ORDER on informal application regarding notice of depositions of Margaret Whitman and subpoena for deposition of Howard Jonas. Signed by Magistrate Judge Patty Shwartz on 02/08/2008. (nr, ) (Entered: 02/15/2008)
- 02/19/2008 192 CERTIFICATION in Opposition re 177 MOTION to Quash Subpoena (Including Only Exhibits Not Subject to Motion to Seal) filed by EBAY, INC., SKYPE TECHNOLOGIES SA, SKYPE, INC.. (Attachments: # 1 Exhibit 1 to Kuo Certification, # 2 Exhibit 2 to Kuo Certification, # 3 Exhibit 4 to Kuo Certification, # 4 Exhibit 5 to Kuo

- Certification, # 5 Exhibit 7 to Kuo Certification, # 6 Exhibit 8 to Kuo Certification, # 7 Exhibit 9 to Kuo Certification, # 8 Exhibit 10 to Kuo Certification, # 9 Exhibit 13 to Kuo Certification)(FENNELLY, KATHLEEN) (Entered: 02/19/2008)
- 02/19/2008 193 BRIEF in Opposition re 177 MOTION to Quash Subpoena filed by EBAY, INC., SKYPE TECHNOLOGIES SA, SKYPE, INC.. (Attachments: # 1 Certification of Marko Kuo, # 2 Exhibit 3 to Kuo Certification, # 3 Exhibit 6 to Kuo Certification, # 4 Exhibit 11 to Kuo Certification, # 5 Exhibit 12 to Kuo Certification, # 6 Exhibit 14 to Kuo Certification, # 7 Exhibit 15 to Kuo Certification, # 8 Exhibit 16 to Kuo Certification, # 9 Exhibit 17 to Kuo Certification, # 10 Exhibit 18 to Kuo Certification, # 11 Exhibit 19 to Kuo Certification)(FENNELLY, KATHLEEN) (Entered: 02/19/2008)
- 02/19/2008 194 MOTION to Seal by EBAY, INC., SKYPE TECHNOLOGIES SA, SKYPE, INC.. (Attachments: # 1 Brief In Support of Motion to Seal, # 2 Declaration of Kathleen N. Fennelly In Support of Motion to Seal, # 3 Text of Proposed Order, # 4 Certificate of Service)(FENNELLY, KATHLEEN) (Entered: 02/19/2008)
- 02/22/2008 195 ORDER granting in part and denying in part (187) Motion to seal & 194 Motion to Seal. Signed by Magistrate Judge Patty Shwartz on 02/21/2008. (nr, ) (Entered: 02/25/2008)
- 02/22/2008 198 ORDER denying 177 Motion to Quash and directing Howard Jonas to appear for a deposition lasting no longer than three and one-half hours, etc.. Signed by Magistrate Judge Patty Shwartz on 02/21/2008. (nr, ) (Entered: 02/26/2008)
- 02/25/2008 196 REPLY to Response to Motion re 177 MOTION to Quash Subpoena filed by HOWARD S. JONAS. (Attachments: # 1 Certification, # 2 Certificate of Service)(LASALA, JOSEPH) (Entered: 02/25/2008)
- 02/25/2008 197 MOTION to Seal Document 196 Reply to Response to Motion by HOWARD S. JONAS. (Attachments: # 1 Brief in Support of Motion to Seal, # 2 Text of Proposed Order, # 3 Declaration, # 4 Certificate of Service)(LASALA, JOSEPH) (Entered: 02/25/2008)
- 02/26/2008 199 ORDER finding as moot 197 Motion to Seal Document; striking reply brief and certification. Signed by Magistrate Judge Patty Shwartz on 02/26/2008. (nr, ) (Entered: 02/27/2008)
- 02/27/2008 200 BRIEF In Opposition to Motion to Quash filed by SKYPE TECHNOLOGIES SA, SKYPE, INC.. (Attachments: # 1 Certification of Marko Kuo, # 2 Exhibit 1 to Certification of Marko Kuo, # 3 Exhibit 2 to Certification of Marko Kuo, # 4 Exhibit 3 to Certification of Marko Kuo, # 5 Exhibit 4 to Certification of Marko Kuo, # 6 Exhibit 5 to Certification of Marko Kuo, # 7 Exhibit 6 to Certification of Marko Kuo, # 8 Exhibit 7 to Certification of Marko Kuo, # 9 Exhibit 8 to Certification of Marko Kuo, # 10 Exhibit 9 to Certification of Marko Kuo, # 11 Exhibit 10 to Certification of Marko Kuo, # 12 Exhibit 11 to Certification of Marko Kuo, # 13 Exhibit 12 to Certification of Marko Kuo, # 14 Exhibit 13 to Certification of Marko Kuo, # 15 Exhibit 14 to Certification of Marko Kuo, # 16 Exhibit 15 to Certification of Marko Kuo, # 17 Exhibit 16 to Certification of Marko Kuo, # 18 Exhibit 17 to Certification of Marko Kuo, # 19 Exhibit 18 to Certification of Marko Kuo, # 20 Exhibit 19 to Certification of Marko Kuo, # 21 Certificate of Service)(FENNELLY, KATHLEEN) (Entered: 02/27/2008)
- 02/27/2008 201 BRIEF filed by EBAY, INC., SKYPE TECHNOLOGIES SA, SKYPE, INC.. (Attachments: # 1 Exhibit 14 to Certification of Marko Kuo, # 2 Exhibit 16 to Certification of Marko Kuo, # 3 Certificate of Service)(FENNELLY, KATHLEEN) (Entered: 02/27/2008)
- 02/29/2008 -- Pro Hac Vice fee: \$ 150, receipt number 200350736 re Perry M. Goldberg (nr, ) (Entered: 02/29/2008)
- 02/29/2008 202 Letter from Joseph La Sala. (LASALA, JOSEPH) (Entered: 02/29/2008)
- 02/29/2008 -- CLERKS QUALITY CONTROL MESSAGE - The Brief Doc. #201 submitted by K. FENNELLY on 2/27/2008 did not contain a proper electronic signature (s/). PLEASE RESUBMIT THE DOCUMENT WITH THE PROPER ELECTRONIC SIGNATURE (s/ Attorneys Name.) This submission will remain on the docket unless otherwise ordered by the court. (nr, ) (Entered: 02/29/2008)
- 03/04/2008 203 Notice of Request by Pro Hac Vice Perry Goldberg to receive Notices of Electronic Filings. (FENNELLY, KATHLEEN) (Entered: 03/04/2008)
- 03/04/2008 204 BRIEF In Opposition to Motion to Quash Jonas Subpoena (re-filed under seal with proper signature) filed by EBAY, INC., SKYPE TECHNOLOGIES SA, SKYPE, INC.. (FENNELLY, KATHLEEN) (Entered: 03/04/2008)
- 03/05/2008 205 ORDER granting the application for a protective order to preclude the deposition of Margaret Whitman. Signed by Magistrate Judge Patty Shwartz on 03/05/2008. (nr, ) (Entered: 03/07/2008)
- 03/18/2008 206 Letter from Joseph La Sala. (LASALA, JOSEPH) (Entered: 03/18/2008)
- 03/20/2008 -- Minute Entry for proceedings held before Magistrate Judge Patty Shwartz: Telephone Conference held on 3/20/2008. (aa, ) (Entered: 03/20/2008)
- 03/24/2008 207 Letter from Thomas R. Curtin. (CURTIN, THOMAS) (Entered: 03/24/2008)
- 03/24/2008 208 Letter from Joseph La Sala, Esq. re 207 Letter. (LASALA, JOSEPH) (Entered: 03/24/2008)
- 03/25/2008 209 Letter from Thomas R. Curtin re 208 Letter. (Attachments: # 1 Exhibit A to March 25 Letter, # 2 Exhibit B to March 25 Letter, # 3 Exhibit C to March 25 Letter, # 4 Exhibit D to March 25 Letter)(CURTIN, THOMAS) (Entered: 03/25/2008)
- 03/25/2008 210 ORDER on informal application granting the request to adjust the pretrial schedule; SCHEDULING ORDER: Telephone Conference set for 5/8/2008 03:00 PM before Magistrate Judge Patty Shwartz., Proposed Pretrial Order due by 10/28/2008., Final Pretrial Conference set for 11/7/2008 01:00 PM before Magistrate Judge Patty Shwartz.. Signed by Magistrate Judge Patty Shwartz on 03/24/2008. (nr, ) (Entered: 03/27/2008)

- 03/28/2008 211 ORDER on informal application granting request to extend pretrial schedule; EIGHTH AMENDED PRETRIAL SCHEDULING ORDER: Telephone Conference set for 5/8/2008 03:00 PM before Magistrate Judge Patty Schwartz., Proposed Pretrial Order due by 10/28/2008., Final Pretrial Conference set for 11/7/2008 10:00 AM before Magistrate Judge Patty Schwartz.. Signed by Magistrate Judge Patty Schwartz on 03/27/2008. (nr, ) (Entered: 03/31/2008)
- 03/31/2008 212 TRANSCRIPT of Proceedings held on February 1, 2008 before Judge Schwartz. PLEASE NOTE: The complete transcript of these proceedings is maintained in paper format on file in the Clerks Office. To request copies of this transcript, contact the Official Court Reporter or Transcription Service who prepared the transcript. (ji, ) (Entered: 04/01/2008)
- 04/17/2008 213 Letter from Joseph P. La Sala. (Attachments: # 1 Text of Proposed Order Order Appointing Mediator)(LASALA, JOSEPH) (Entered: 04/17/2008)
- 04/18/2008 214 Letter from Joseph P. La Sala. (Attachments: # 1 Text of Proposed Order Consent Order Appointing Mediator) (LASALA, JOSEPH) (Entered: 04/18/2008)
- 04/21/2008 215 Letter from Ronald J. Hedges, Special Master. (Attachments: # 1 Findings of Fact and Conclusions of Law) (HEDGES, RONALD) (Entered: 04/21/2008)
- 04/22/2008 216 ORDER on informal application denying pltf's application to preclude the deft. from relying on VocalTec's prior art and for the appointment of the Special Master; etc.. Signed by Magistrate Judge Patty Schwartz on 04/22/2008. (nr, ) (Entered: 04/24/2008)
- 04/24/2008 217 Order Appointing Mediator, RONALD J. HEDGES rep by RONALD J. HEDGES appointed.. Signed by Magistrate Judge Patty Schwartz on 04/18/2008. (nr, ) (Entered: 04/25/2008)
- 05/02/2008 -- The telephone status conference set for 5/8/2008 has been adjourned until 5/16/08 at 11:00 AM in Newark before Magistrate Judge Patty Schwartz. Plaintiff's attorney shall initiate the conference call. Signed by Magistrate Judge Patty Schwartz on 5/2/08. (drc, ) (Entered: 05/02/2008)
- 05/02/2008 218 ORDER on informal application directing that any objections to any report of the Special Master shall be filed with the undersigned in accordance with the deadlines set forth in the FRCP. Signed by Magistrate Judge Patty Schwartz on 04/23/2008. (nr, ) (Entered: 05/05/2008)
- 05/05/2008 219 NOTICE by NET2PHONE, INC. re 215 Letter Net2Phone Inc.'s Rule 53(f) Objections and Motion to Modify Findings of Fact and Conclusions of Law of Special Master Dated April 21, 2008 (Attachments: # 1 Brief, # 2 Text of Proposed Order, # 3 Certificate of Service)(LASALA, JOSEPH) (Entered: 05/05/2008)
- 05/05/2008 220 NOTICE by NET2PHONE, INC. re 219 Notice (Other), Notice (Other) Declaration by Hannah Stott-Bumsted concerning documents submitted for in camera review (LASALA, JOSEPH) (Entered: 05/05/2008)
- 05/05/2008 221 NOTICE by NET2PHONE, INC. re 219 Notice (Other), Notice (Other) Declaration of Hannah Stott-Bumsted concerning attached Exhibits (Attachments: # 1 Exhibit Ex. 1, # 2 Exhibit Ex. 2, # 3 Exhibit Ex. 3, # 4 Exhibit Ex. 4, # 5 Exhibit Ex. 5.1, # 6 Exhibit Ex. 5.2, # 7 Exhibit Ex. 6, # 8 Exhibit Ex. 7, # 9 Exhibit Ex. 8, # 10 Exhibit Ex. 9.1, # 11 Exhibit Ex. 9.2, # 12 Exhibit Ex. 10, # 13 Exhibit Ex. 11, # 14 Exhibit Ex. 12, # 15 Exhibit Ex. 13, # 16 Exhibit Ex. 14, # 17 Exhibit Ex. 15, # 18 Exhibit Ex. 16, # 19 Exhibit Ex. 17, # 20 Exhibit Ex. 18, # 21 Exhibit Ex. 19, # 22 Exhibit Ex. 20, # 23 Exhibit Ex. 21, # 24 Exhibit Ex. 22, # 25 Exhibit Ex. 23, # 26 Exhibit Ex. 24, # 27 Exhibit Ex. 25, # 28 Exhibit Ex. 26)(LASALA, JOSEPH) (Entered: 05/05/2008)
- 05/06/2008 222 MOTION to Seal Document 221 Notice (Other), Notice (Other), Notice (Other), Notice (Other), 219 Notice (Other), Notice (Other) by NET2PHONE, INC.. (Attachments: # 1 Brief, # 2 Text of Proposed Order, # 3 Declaration Declaration of Hannah Stott-Bumsted concerning Exhibits to Motion to Seal, # 4 Exhibit Ex. 1, # 5 Exhibit Ex. 2B, # 6 Exhibit Ex. 3B, # 7 Exhibit Ex. 4B, # 8 Exhibit Ex. 5B, # 9 Exhibit Ex. 6B, # 10 Exhibit Ex. 7B, # 11 Exhibit Ex. 8B, # 12 Exhibit Ex. 9B, # 13 Exhibit Ex. 10B, # 14 Exhibit Ex. 12B, # 15 Exhibit Ex. 13B, # 16 Exhibit Ex. 14B, # 17 Exhibit Ex. 15B, # 18 Exhibit Ex. 16B, # 19 Exhibit 17B, # 20 Exhibit Ex. 18B, # 21 Certificate of Service)(LASALA, JOSEPH) (Entered: 05/06/2008)
- 05/06/2008 223 NOTICE by NET2PHONE, INC. re 222 MOTION to Seal Document 221 Notice (Other), Notice (Other), Notice (Other), Notice (Other), 219 Notice (Other), Notice (Other) MOTION to Seal Document 221 Notice (Other), Notice (Other), Notice (Other), Notice (Other), 219 Notice (Other), Notice (Other) MOTION to Seal Document 221 Notice (Other), Notice (Other), Notice (Other), Notice (Other), 219 Notice (Other), Notice (Other) Declaration of Hannah Stott-Bumsted concerning Exhibits in Support of Motion to Seal (Attachments: # 1 Exhibit Ex. 2A, # 2 Exhibit Ex. 3A, # 3 Exhibit Ex. 4A, # 4 Exhibit 5A, # 5 Exhibit Ex. 6A, # 6 Exhibit Ex. 7A, # 7 Exhibit Ex. 8A, # 8 Exhibit 9A, # 9 Exhibit 10A, # 10 Exhibit Ex. 11, # 11 Exhibit Ex. 12A, # 12 Exhibit Ex. 13A, # 13 Exhibit Ex. 14A, # 14 Exhibit Ex. 15A, # 15 Exhibit Ex. 16A, # 16 Exhibit Ex. 17A, # 17 Exhibit Ex. 18A)(LASALA, JOSEPH) (Entered: 05/06/2008)
- 05/06/2008 -- CLERKS QUALITY CONTROL MESSAGE - The Motions & Declarations -Doc. Nos. 219, 220, 221, & 223 filed by JOSEPH LASALA on 5/5/2008 & 5/6/2008 was submitted incorrectly as NOTICES. PLEASE RESUBMIT THE Motions & Declarations using the correct events. This submission will remain on the docket unless otherwise ordered by the court. (nr, ) (Entered: 05/06/2008)
- 05/06/2008 224 MOTION Rule 53(f) Objections and Motion to Modify Findings of Fact and Conclusions of Law of Special Master Dated April 21, 2008 re 222 MOTION to Seal Document 221 Notice (Other), Notice (Other), Notice (Other), Notice (Other), 219 Notice (Other), Notice (Other) MOTION to Seal Document 221 Notice (Other), Notice (Other), Notice (Other), Notice (Other), 219 Notice (Other), Notice (Other) MOTION to Seal Document 221 Notice (Other), Notice (Other), Notice (Other), Notice (Other), 219 Notice (Other), Notice (Other), 220 Notice (Other), 221 Notice (Other), Notice (Other), Notice (Other), Notice (Other), Notice (Other), 215 Letter, 219 Notice (Other),



- Notice (Other) by NET2PHONE, INC.. (Attachments: # 1 Brief Redacted brief, # 2 Text of Proposed Order, # 3 Declaration Decl. of Hannah Stott-Bumsted concerning documents submitted for in camera review, # 4 Declaration Redacted Decl. of Hannah Stott-Bumsted concerning attached Exhibits, # 5 Exhibit Ex. 2, # 6 Exhibit Ex. 5.1, # 7 Exhibit Ex. 5.2, # 8 Exhibit Ex. 7, # 9 Exhibit Ex. 8, # 10 Exhibit Ex. 9.1, # 11 Exhibit Ex. 9.2, # 12 Exhibit Ex. 10, # 13 Exhibit Ex. 13, # 14 Exhibit Ex. 19, # 15 Exhibit Ex. 20, # 16 Exhibit Ex. 21, # 17 Exhibit Ex. 24, # 18 Exhibit Ex. 26, # 19 Certificate of Service)(LASALA, JOSEPH) (Entered: 05/06/2008)
- 05/06/2008 225 BRIEF in Support of Rule 53(f) Objections and Motion to Modify Findings of Fact and Conclusions of Law of Special Master Dated April 21, 2008 filed by NET2PHONE, INC.. (LASALA, JOSEPH) (Entered: 05/06/2008)
- 05/06/2008 226 DECLARATION of Hannah Stott-Bumsted in Support of Rule 53(f) Objections and Motion to Modify Findings of Fact and Conclusions of Law of Special Master Dated April 21, 2008 by NET2PHONE, INC.. (Attachments: # 1 Exhibit Ex. 1, # 2 Exhibit Ex. 3, # 3 Exhibit Ex. 4, # 4 Exhibit Ex. 6, # 5 Exhibit Ex. 11, # 6 Exhibit Ex. 12, # 7 Exhibit Ex. 14, # 8 Exhibit Ex. 15, # 9 Exhibit Ex. 16, # 10 Exhibit Ex. 17, # 11 Exhibit Ex. 18, # 12 Exhibit Ex. 22, # 13 Exhibit Ex. 23, # 14 Exhibit Ex. 25)(LASALA, JOSEPH) (Entered: 05/06/2008)
- 05/06/2008 227 DECLARATION of Hannah Stott-Bumsted re 222 MOTION to Seal Document 221 Notice (Other), Notice (Other), Notice (Other), Notice (Other), 219 Notice (Other), Notice (Other) MOTION to Seal Document 221 Notice (Other), Notice (Other), Notice (Other), Notice (Other), 219 Notice (Other), Notice (Other) MOTION to Seal Document 221 Notice (Other), Notice (Other), Notice (Other), Notice (Other), 219 Notice (Other), Notice (Other), 223 Notice (Other), Notice (Other), Notice (Other), Notice (Other) in support of Motion to Seal by NET2PHONE, INC.. (Attachments: # 1 Exhibit Ex. 2A, # 2 Exhibit Ex. 3A, # 3 Exhibit Ex. 4A, # 4 Exhibit Ex. 5A, # 5 Exhibit Ex. 6A, # 6 Exhibit Ex. 7A, # 7 Exhibit Ex. 8A, # 8 Exhibit Ex. 9A, # 9 Exhibit Ex. 10A, # 10 Exhibit Ex. 11, # 11 Exhibit Ex. 12A, # 12 Exhibit Ex. 13A, # 13 Exhibit Ex. 14A, # 14 Exhibit Ex. 15A, # 15 Exhibit Ex. 16A, # 16 Exhibit Ex. 17A, # 17 Exhibit Ex. 18A)(LASALA, JOSEPH) (Entered: 05/06/2008)
- 05/06/2008 -- Set Deadlines as to 222 MOTION to Seal Document 221 Notice (Other), Notice (Other), Notice (Other), Notice (Other), 219 Notice (Other), Notice (Other) MOTION to Seal Document 221 Notice (Other), Notice (Other), Notice (Other), Notice (Other), 219 Notice (Other), Notice (Other) MOTION to Seal Document 221 Notice (Other), Notice (Other), Notice (Other), Notice (Other), 219 Notice (Other), Notice (Other). Motion Hearing set for 6/2/2008 10:00 AM before Judge Katharine S. Hayden. (PLEASE BE ADVISED THAT THIS MOTION WILL BE DECIDED ON THE PAPERS UNLESS OTHERWISE NOTIFIED BY THE COURT)(nr, ) (Entered: 05/12/2008)
- 05/06/2008 -- Set Deadlines as to 224 Motion Motion Hearing set for 6/2/2008 10:00 AM before Judge Katharine S. Hayden. (nr, ) (PLEASE BE ADVISED THAT THIS MOTION WILL BE DECIDED ON THE PAPERS UNLESS OTHERWISE NOTIFIED BY THE COURT) (Entered: 05/12/2008)
- 05/16/2008 230 ORDER on informal application scheduling a telephone conference on May 21, 2008 at 5:00p.m. to address pltf's application to strike the Vocal Tec evidence; documents identified by pltf. as confidential shall be made available for inspection to Professor Maggs, etc.. Signed by Magistrate Judge Patty Shwartz on 05/16/2008. (nr, ) (Entered: 05/20/2008)
- 05/16/2008 231 ORDER on informal application regarding the special master; Telephone Conference set for 5/19/2008 06:00 PM with the Special Master. Signed by Magistrate Judge Patty Shwartz on 05/16/2008. (nr, ) (Entered: 05/20/2008)
- 05/16/2008 -- Minute Entry for proceedings held before Magistrate Judge Patty Shwartz: Telephone Conference held on 5/16/2008. (aa, ) (Entered: 05/28/2008)
- 05/19/2008 228 APPLICATION/PETITION for by EBAY, INC., SKYPE TECHNOLOGIES SA, SKYPE, INC.. (Attachments: # 1 Text of Proposed Order (Unopposed) To Extend Time for eBay and Skype to Respond to Rule 53 (f) Objections, # 2 Certificate of Service)(FENNELLY, KATHLEEN) (Entered: 05/19/2008)
- 05/19/2008 229 RESPONSE in Opposition re 222 MOTION to Seal Document 221 Notice (Other), Notice (Other), Notice (Other), Notice (Other), 219 Notice (Other), Notice (Other) MOTION to Seal Document 221 Notice (Other), Notice (Other), Notice (Other), Notice (Other), 219 Notice (Other), Notice (Other) MOTION to Seal Document 221 Notice (Other), Notice (Other), Notice (Other), Notice (Other), 219 Notice (Other), Notice (Other) filed by EBAY, INC., SKYPE TECHNOLOGIES SA, SKYPE, INC.. (Attachments: # 1 Certificate of Service)(FENNELLY, KATHLEEN) (Entered: 05/19/2008)
- 05/21/2008 232 RESPONSE in Opposition to Net2Phone's Objections to the Report of the Special Master filed by SKYPE TECHNOLOGIES SA, SKYPE, INC.. (Attachments: # 1 Brief, # 2 Declaration of Andrew D. Weiss, Esq., # 3 Exhibit A, # 4 Exhibit B, # 5 Exhibit C, # 6 Exhibit D, # 7 Exhibit E, # 8 Certificate of Service)(FENNELLY, KATHLEEN) (Entered: 05/21/2008)
- 05/21/2008 233 RESPONSE in Opposition to Net2Phone's Objections to the Report of the Special Master filed by SKYPE TECHNOLOGIES SA, SKYPE, INC.. (Attachments: # 1 Brief, # 2 Declaration of Andrew D. Weiss, Esq., # 3 Exhibit A, # 4 Errata B, # 5 Exhibit C, # 6 Exhibit D, # 7 Exhibit E, # 8 Certificate of Service)(FENNELLY, KATHLEEN) (Entered: 05/21/2008)
- 05/21/2008 234 ORDER on informal application advising that absent a request to reschedule same by May 28, 2008 there shall be an evidentiary hrg. concerning the pltf's request to strike the Vocal Tec documents on June 27, 2008 at 9:30a.m.; etc.. Signed by Magistrate Judge Patty Shwartz on 05/21/2008. (nr, ) (Entered: 05/27/2008)
- 05/21/2008 -- Minute Entry for proceedings held before Magistrate Judge Patty Shwartz: Telephone Conference held on 5/21/2008. (aa, ) (Entered: 05/28/2008)
- 05/23/2008 235 ORDER extending deadline to respond to Net2phone's objection to May 21, 2008;. Signed by Magistrate Judge Patty Shwartz on 05/20/2008. (nr, ) (Entered: 05/27/2008)

- 06/02/2008 236 ORDER on informal application granting pltf's request to submit reply brief. Signed by Magistrate Judge Patty Shwartz on 06/02/2008. (nr, ) (Entered: 06/03/2008)
- 06/02/2008 237 ORDER on informal application denying pltf's request to modify the order dated May 6, 2008. Signed by Magistrate Judge Patty Shwartz on 06/02/2008. (nr, ) (Entered: 06/04/2008)
- 06/05/2008 238 REPLY to Response to Motion Rule 53 Objections and Motion to Modify Findings of Fact and Conclusions of Law of Special Master Dated April 21, 2008 filed by NET2PHONE, INC.. (Attachments: # 1 Declaration Declaration of Steven R. Ruby, # 2 Exhibit Ex. 27, # 3 Exhibit Ex. 28, # 4 Exhibit Ex. 29, # 5 Exhibit Ex. 30, # 6 Exhibit Ex. 31, # 7 Certificate of Service)(LASALA, JOSEPH) (Entered: 06/05/2008)
- 06/05/2008 239 REPLY to Response to Motion Rule 53 Objections and Motion to Modify Findings of Fact and Conclusions of Law of Special Master Dated April 21, 2008 filed by NET2PHONE, INC.. (Attachments: # 1 Declaration Declaration of Steven R. Ruby, # 2 Exhibit Redacted Ex. 27, # 3 Exhibit Redacted Ex. 28, # 4 Exhibit Redacted Ex. 29, # 5 Exhibit Redacted Ex. 30, # 6 Exhibit Redacted Ex. 31, # 7 Certificate of Service)(LASALA, JOSEPH) (Entered: 06/05/2008)
- 06/12/2008 240 NOTICE of Appearance by JOSEPH P. LASALA on behalf of NET2PHONE, INC. (Attachments: # 1 Certificate of Service)(LASALA, JOSEPH) (Entered: 06/12/2008)
- 06/26/2008 241 Letter from Thomas R. Curtin, Esq.. (CURTIN, THOMAS) (Entered: 06/26/2008)
- 06/26/2008 242 Letter from Joseph P. La Sala. (Attachments: # 1 Certificate of Service)(LASALA, JOSEPH) (Entered: 06/26/2008)
- 06/26/2008 243 OPINION. Signed by Magistrate Judge Patty Shwartz on 06/25/2008. (nr, ) (Entered: 06/27/2008)
- 06/26/2008 244 ORDER affirming the Special Master's report in its entirety; denying 222 Motion to Seal Document. Signed by Magistrate Judge Patty Shwartz on 06/25/2008. (nr, ) (Entered: 06/27/2008)
- 06/27/2008 -- Minute Entry for proceedings held before Magistrate Judge Patty Shwartz: Evidentiary Hearing held on 6/27/2008. (Court Reporter Margaret Vollmuth.) (aa, ) (Entered: 07/02/2008)
- 06/30/2008 245 ORDER administratively terminating 123 Motion to Strike. Signed by Judge Katharine S. Hayden on 6/30/08. (rg, ) (Entered: 06/30/2008)
- 06/30/2008 246 ORDER on informal application granting request for an extension of time to produce the documents that are the subject of the Special Master's report and Order dated June 25, 2008. Signed by Magistrate Judge Patty Shwartz on 06/30/2008. (nr, ) (Entered: 07/01/2008)
- 07/03/2008 247 ORDER on informal application denying pltf's request under Fed. R. Civ. P. that the Court preclude reliance on the Vocal Tec prior art and directing the pltf. to issue a supplemental expert report that address the Vocal Tec prior art. Signed by Magistrate Judge Patty Shwartz on 07/03/2008. (nr, ) (Entered: 07/08/2008)
- 07/10/2008 248 MOTION for Leave to Appear Pro Hac Vice by NET2PHONE, INC.. (Attachments: # 1 Affidavit Joseph P. La Sala pro hac vice Russell Shay Glass, # 2 Affidavit of Russell Shay Glass, # 3 Certificate of Service, # 4 Text of Proposed Order)(LASALA, JOSEPH) (Entered: 07/10/2008)
- 07/10/2008 249 MOTION for Leave to Appear Pro Hac Vice by NET2PHONE, INC.. (Attachments: # 1 Affidavit, # 2 Affidavit, # 3 Certificate of Service, # 4 Text of Proposed Order)(LASALA, JOSEPH) (Entered: 07/10/2008)
- 07/10/2008 250 MOTION for Leave to Appear Pro Hac Vice by NET2PHONE, INC.. (Attachments: # 1 Affidavit JPLS in support of motion for an order admitting Victor Aronoff Kubli, Esq. Pro Hac Vice, # 2 Affidavit of Victor Aronoff Kubli, Esq., # 3 Certificate of Service, # 4 Text of Proposed Order)(LASALA, JOSEPH) (Entered: 07/10/2008)
- 07/11/2008 252 ORDER granting 250 Motion for Russell Shay Glass, Sarah Brashears Macatee and Victor Aronoff Kubli to Appear Pro Hac Vice. Signed by Magistrate Judge Patty Shwartz on 07/11/2008. (nr, ) (Entered: 07/15/2008)
- 07/14/2008 251 TRANSCRIPT of Proceedings held on 7/3/08 before Judge Shwartz. PLEASE NOTE: The complete transcript of these proceedings is maintained in paper format on file in the Clerks Office. To request copies of this transcript, contact the Official Court Reporter or Transcription Service who prepared the transcript. (jgb) (Entered: 07/15/2008)
- 07/22/2008 253 APPEAL OF MAGISTRATE JUDGE DECISION to District Court by NET2PHONE, INC. re 247 Order on Oral Motion, (Attachments: # 1 Brief, # 2 Text of Proposed Order, # 3 Certificate of Service)(LASALA, JOSEPH) (Entered: 07/22/2008)
- 07/22/2008 254 DECLARATION re 253 APPEAL OF MAGISTRATE JUDGE DECISION to District Court by NET2PHONE, INC. re 247 Order on Oral Motion, by NET2PHONE, INC.. (Attachments: # 1 Exhibit, # 2 Exhibit, # 3 Exhibit, # 4 Exhibit, # 5 Exhibit, # 6 Exhibit, # 7 Exhibit, # 8 Exhibit, # 9 Exhibit, # 10 Exhibit, # 11 Exhibit, # 12 Exhibit, # 13 Exhibit, # 14 Exhibit, # 15 Exhibit, # 16 Exhibit, # 17 Exhibit, # 18 Exhibit, # 19 Exhibit, # 20 Exhibit, # 21 Exhibit, # 22 Exhibit, # 23 Exhibit, # 24 Exhibit, # 25 Exhibit, # 26 Exhibit, # 27 Exhibit, # 28 Exhibit, # 29 Exhibit)(LASALA, JOSEPH) (Entered: 07/23/2008)
- 07/22/2008 -- Set Deadlines as to 253 APPEAL OF MAGISTRATE JUDGE DECISION to District Court by NET2PHONE, INC. re 247 Order on Oral Motion,. Motion Hearing set for 8/18/2008 10:00 AM before Judge Katharine S. Hayden. (nr, ) (PLEASE BE ADVISED THAT THIS MOTION WILL BE DECIDED ON THE PAPERS UNLESS OTHERWISE NOTIFIED BY THE COURT) (Entered: 07/23/2008)
- 07/24/2008 255 MOTION for Leave to File Amended Reply to Amended Counterclaim by NET2PHONE, INC.. (Attachments: # 1 Exhibit A)(LASALA, JOSEPH) (Entered: 07/24/2008)

- 07/24/2008 256 MOTION for Leave to Appear Pro Hac Vice by NET2PHONE, INC.. (Attachments: # 1 Affidavit JPLS in support of motion to admit Alan M. Fisch, Esq. and Coke Morgan Stewart, Esq. pro hac vice, # 2 Affidavit Alan M. Fisch, Esq., # 3 Affidavit of Coke Morgan Stewart, Esq., # 4 Certificate of Service Certification of Service and Filing, # 5 Text of Proposed Order Proposed Order)(LASALA, JOSEPH) (Entered: 07/24/2008)
- 07/24/2008 257 NOTICE of Appearance by JOSEPH P. LASALA on behalf of NET2PHONE, INC. (Attachments: # 1 Certificate of Service Certification of Service and Filing)(LASALA, JOSEPH) (Entered: 07/24/2008)
- 07/24/2008 -- Set Deadlines as to 255 MOTION for Leave to File Amended Reply to Amended Counterclaim . Motion Hearing set for 8/18/2008 10:00 AM before Judge Katharine S. Hayden. (nr, ) (PLEASE BE ADVISED THAT THIS MOTION WILL BE DECIDED ON THE PAPERS UNLESS OTHERWISE NOTIFIED BY THE COURT) (Entered: 07/25/2008)
- 07/24/2008 -- Set Deadlines as to 256 MOTION for Leave to Appear Pro Hac Vice. Motion Hearing set for 8/18/2008 10:00 AM before Judge Katharine S. Hayden. (nr, )(PLEASE BE ADVISED THAT THIS MOTION WILL BE DECIDED ON THE PAPERS UNLESS OTHERWISE NOTIFIED BY THE COURT) (Entered: 07/25/2008)
- 07/25/2008 258 NOTICE by NET2PHONE, INC. of Withdrawal of Appearance (LASALA, JOSEPH) (Entered: 07/25/2008)
- 07/25/2008 259 Letter from Kathleen Fennelly Re: Motion for Leave to File Amended Reply re 255 MOTION for Leave to File Amended Reply to Amended Counterclaim . (FENNELLY, KATHLEEN) (Entered: 07/25/2008)
- 07/28/2008 260 ORDER granting 255 Motion for Leave to File an amended reply to the counterclaim. Signed by Magistrate Judge Patty Shwartz on 07/25/2008. (nr, ) (Entered: 07/29/2008)
- 07/30/2008 261 Letter from Kathleen N. Fennelly Requesting Extension of Time to Reply to Magistrate Appeal re Set/Reset Motion and R&R Deadlines/Hearings, 254 Declaration,,. (FENNELLY, KATHLEEN) (Entered: 07/30/2008)
- 07/31/2008 262 ORDER granting defendant's letter request dated July 30, 2008. Signed by Judge Katharine S. Hayden on 7/31/08. (rg, ) (Entered: 08/01/2008)
- 08/04/2008 263 AFFIDAVIT of Coke Morgan Stewart, Esq. re 256 MOTION for Leave to Appear Pro Hac Vice by NET2PHONE, INC.. (Attachments: # 1 Affidavit Amended Affidavit of Alan M. Fisch, Esq., # 2 Certificate of Service of JPLS for Amended Affidavit of Alan M. Fisch and Coke Morgan Stewart)(LASALA, JOSEPH) (Entered: 08/04/2008)
- 08/04/2008 -- Minute Entry for proceedings held before Magistrate Judge Patty Shwartz: Telephone Conference held on 8/4/2008. (aa, ) (Entered: 08/05/2008)
- 08/04/2008 268 ORDER granting 256 Motion for Coke Morgan Stewart and Alan M. Fisch to Appear Pro Hac Vice on behalf of plaintiff. Signed by Magistrate Judge Patty Shwartz on 8/4/08. (cs, ) (Entered: 08/07/2008)
- 08/05/2008 264 ORDER on informal application for production of documents and directing depts. to reopen the depositions of Messrs. Jonas, DiGiorgio, Alroy, Skelton, and Greenstein, etc.. Signed by Magistrate Judge Patty Shwartz on 08/04/2008. (nr, ) (Entered: 08/06/2008)
- 08/07/2008 265 Notice of Request by Pro Hac Vice Russell Shay Glass to receive Notices of Electronic Filings. ( Pro Hac Vice fee \$ 150 receipt number 0312000000002128665.) (LASALA, JOSEPH) (Entered: 08/07/2008)
- 08/07/2008 266 Notice of Request by Pro Hac Vice Sarah Brashears Macatee to receive Notices of Electronic Filings. ( Pro Hac Vice fee \$ 150 receipt number 0312000000002128741.) (LASALA, JOSEPH) (Entered: 08/07/2008)
- 08/07/2008 267 Notice of Request by Pro Hac Vice Victor Aronoff Kubli to receive Notices of Electronic Filings. ( Pro Hac Vice fee \$ 150 receipt number 0312000000002128807.) (LASALA, JOSEPH) (Entered: 08/07/2008)
- 08/07/2008 269 MOTION for Leave to Appear Pro Hac Vice by NET2PHONE, INC.. (Attachments: # 1 Affidavit JPLS in support of motion to admit Alan M. Grayson pro hac vice, # 2 Affidavit Alan M Grayson in support of motion pro hac vice, # 3 Certificate of Service JPLS for pro hac vice Alan M. Grayson, # 4 Text of Proposed Order)(LASALA, JOSEPH) (Entered: 08/07/2008)
- 08/07/2008 -- Set Deadlines as to 269 MOTION for Leave to Appear Pro Hac Vice. Motion Hearing set for 9/2/2008 10:00 AM before Judge Katharine S. Hayden. (nr, ) (PLEASE BE ADVISED THAT THIS MOTION WILL BE DECIDED ON THE PAPERS UNLESS OTHERWISE NOTIFIED BY THE COYRT) (Entered: 08/08/2008)
- 08/08/2008 -- Pro Hac Vice fee: \$ 450, receipt number 2128665,2128741,2128807 re Russell Shay Glass, Sarah Brachears Macatee & Victor Aronoff Kubli (nr, ) (Entered: 08/08/2008)
- 08/08/2008 270 STIPULATION re 264 Order on Oral Motion Joint Proposed Order Amending Pretrial Schedule by NET2PHONE, INC., EBAY, INC., SKYPE TECHNOLOGIES SA, SKYPE, INC.. (FENNELLY, KATHLEEN) (Entered: 08/08/2008)
- 08/08/2008 271 ORDER granting 269 Motion for Alan Mark Grayson to Appear Pro Hac Vice. Signed by Magistrate Judge Patty Shwartz on 08/08/2008. (nr, ) (Entered: 08/11/2008)
- 08/12/2008 272 ORDER amending pretrial schedule. Signed by Magistrate Judge Patty Shwartz on 08/08/2008. (nr, ) (Entered: 08/13/2008)
- 08/15/2008 273 Notice of Request by Pro Hac Vice Alan M. Grayson to receive Notices of Electronic Filings. ( Pro Hac Vice fee \$ 150 receipt number 0312000000002140931.) (LASALA, JOSEPH) (Entered: 08/15/2008)
- 08/15/2008 274 Notice of Request by Pro Hac Vice Coke Morgan Stewart to receive Notices of Electronic Filings. ( Pro Hac Vice fee \$ 150 receipt number 0312000000002141440.) (LASALA, JOSEPH) (Entered: 08/15/2008)
- 08/15/2008 275 Notice of Request by Pro Hac Vice Alan M. Fisch to receive Notices of Electronic Filings. ( Pro Hac Vice fee \$ 150 receipt number 0312000000002141576.) (LASALA, JOSEPH) (Entered: 08/15/2008)

- 08/18/2008 276 BRIEF Skype's Opposition to Net2Phone's Rule 72 Objection to the Order of Magistrate Judge Shwartz filed by EBAY, INC., SKYPE TECHNOLOGIES SA, SKYPE, INC.. (Attachments: # 1 Declaration of Benjamin Wang, # 2 Exhibit 1 to Wang Declaration, # 3 Exhibit 2 to Wang Declaration, # 4 Exhibit 3 to Wang Declaration, # 5 Exhibit 4 to Wang Declaration, # 6 Exhibit 5 to Wang Declaration, # 7 Exhibit 6 to Wang Declaration, # 8 Exhibit 7 to Wang Declaration, # 9 Exhibit 8 to Wang Declaration, # 10 Exhibit 9 to Wang Declaration, # 11 Exhibit 10 to Wang Declaration, # 12 Exhibit 11 to Wang Declaration, # 13 Exhibit 12 to Wang Declaration, # 14 Errata 13 to Wang Declaration, # 15 Exhibit 14 to Wang Declaration, # 16 Exhibit 15 to Wang Declaration, # 17 Exhibit 16 to Wang Declaration, # 18 Exhibit 17 to Wang Declaration, # 19 Exhibit 18 to Wang Declaration, # 20 Exhibit 19 to Wang Declaration, # 21 Exhibit 20 to Wang Declaration, # 22 Exhibit 21 to Wang Declaration, # 23 Exhibit 22 to Wang Declaration, # 24 Exhibit 23 to Wang Declaration, # 25 Exhibit 24 to Wang Declaration, # 26 Exhibit 25 to Wang Declaration, # 27 Exhibit 26 to Wang Declaration, # 28 Exhibit 27 to Wang Declaration, # 29 Errata 28 to Wang Declaration, # 30 Exhibit 29 to Wang Declaration, # 31 Exhibit 30 to Wang Declaration, # 32 Exhibit 31 to Wang Declaration, # 33 Exhibit 32 to Wang Declaration, # 34 Exhibit 33 to Wang Declaration, # 35 Exhibit 34 to Wang Declaration, # 36 Certificate of Service)(CURTIN, THOMAS) (Entered: 08/18/2008)
- 08/20/2008 277 Letter from Kathleen N. Fennelly Re: Relaxation of Brief Page Limits. (FENNELLY, KATHLEEN) (Entered: 08/20/2008)
- 08/21/2008 278 Letter from Joseph P. La Sala to Judge Hayden re Summary Judgment Page Extension. (LASALA, JOSEPH) (Entered: 08/21/2008)
- 08/22/2008 279 ORDER denying letter request dated August 20, 2008 by defendants eBay, Inc. and Skype which requested leave to file an over-length brief. Signed by Judge Katharine S. Hayden on 8/22/08. (rg, ) (Entered: 08/22/2008)
- 08/26/2008 -- Pro Hac Vice fee: \$ 450., receipt number 2140931,2141440,2141 576 re Alan Grayson, Coke Morgan Stewart & Alan M. Fisch (nr, ) (Entered: 08/26/2008)
- 08/29/2008 280 Letter from Joseph P. La Sala. (Attachments: # 1 Exhibit Exhibits A through E to Joint Letter, # 2 Exhibit Exhibit F - Part I, # 3 Exhibit Exhibit F - Part 2, # 4 Exhibit Exhibit F - Part 3, # 5 Exhibit Exhibits 1 through 3) (LASALA, JOSEPH) (Entered: 08/29/2008)
- 09/08/2008 281 ORDER on informal application overruling the efforts to limit the pltf's expert access to the source code or test environment; denying pltf's request to modify the terms of access; and mootng def't's request to compel pltf. to provide its portion about Mr. Derwin's deposition. Signed by Magistrate Judge Patty Shwartz on 09/05/2008. (nr, ) (Entered: 09/09/2008)
- 09/08/2008 282 ORDER on informal application granting request to continue Mr. Derwin's deposition; granting request to compel the production of documents from Mr. Derwin. Signed by Magistrate Judge Patty Shwartz on 09/05/2008. (nr, ) (Entered: 09/09/2008)
- 09/10/2008 283 Letter from Joseph P. La Sala to Judge Shwartz. (LASALA, JOSEPH) (Entered: 09/10/2008)
- 09/15/2008 284 TRANSCRIPT of Proceedings held on September 5, 2008 before Judge Shwartz. Court Reporter/Recorder: King Transcription Services. PLEASE NOTE: The complete transcript of these proceedings is maintained in paper format on file in the Clerks Office. To request copies of this transcript, contact the Official Court Reporter or Transcription Service who prepared the transcript. (ji, ) (Entered: 09/15/2008)
- 09/16/2008 285 ORDER on informal application granting requesting to extend deadline to disclose supplemental expert reports; directing that all summary judgment motions be filed no later than 10/10/2008 and setting briefing schedule. Signed by Magistrate Judge Patty Shwartz on 09/15/2008. (nr, ) (Entered: 09/17/2008)
- 09/17/2008 286 MOTION to Seal by NET2PHONE, INC.. (Attachments: # 1 Brief Brief in Support of Notice of Motion to Seal, # 2 Certification of JPLS in support of Motion to Seal, # 3 Exhibit to Certification of JPLS in support of motion to seal, # 4 Exhibit #2 to Certification of JPLS in support of motion to seal, # 5 Text of Proposed Order Propose Order to Seal, # 6 Certificate of Service of Motion to Seal)(LASALA, JOSEPH) (Entered: 09/17/2008)
- 09/17/2008 287 NOTICE by NET2PHONE, INC. Rule 53(f) Objections and Motion to Modify Findings of Fact and Conclusions of Law of Special Master Dated September 4, 2008 (Attachments: # 1 Certification of JPLS in support of Rule 53 (f) objections and motion to modify findings of fact and conclusions of law of Special Master dated September 17, 2008, # 2 Exhibit # 1, # 3 Exhibit #2, # 4 Brief Redacted Brief in support of plaintiff's objectin to the Special Master's Ruling on Privilege Log Entry 9072, # 5 Text of Proposed Order, # 6 Certificate of Service of JPLS)(LASALA, JOSEPH) (Entered: 09/17/2008)
- 09/17/2008 288 AMENDED DOCUMENT by NET2PHONE, INC.. Amendment to 286 MOTION to Seal Amended Certification of JPLS to add Electronic Signature . (LASALA, JOSEPH) (Entered: 09/17/2008)
- 09/17/2008 -- Set Deadlines as to 289 MOTION to Seal. Motion Hearing set for 10/20/2008 10:00 AM before Judge Katharine S. Hayden. (nr, )(PLEASE BE ADVISED THAT THIS MOTION WILL BE DECIDED ON THE PAPERS UNLESS OTHERWISE NOTIFIED BY THE COURT) (Entered: 09/22/2008)
- 09/18/2008 -- CLERK'S NOTE: document #246 was filed without motion. Counsel to file Motion to Seal (only). See doc #246 for supporting papers. (jd, ) (Entered: 09/18/2008)
- 09/18/2008 -- CLERK'S NOTE: Please be advised the correct document # is 286 (motion to seal) not doc #246 (jd, ) (Entered: 09/18/2008)
- 09/18/2008 289 MOTION to Seal by NET2PHONE, INC.. (LASALA, JOSEPH) (Entered: 09/18/2008)
- 09/19/2008 290 AMENDED DOCUMENT by NET2PHONE, INC.. Amendment to 287 Notice (Other), Notice (Other), Notice

- (Other) Redacted Brief in Support of Plaintiff's Objection to the Special Master's Ruling on Privilege Log Entry 9072. (LASALA, JOSEPH) (Entered: 09/19/2008)
- 09/19/2008 291 Letter from Joseph P. La Sala enclosing Proposed Order to Seal. (Attachments: # 1 Proposed Order to Seal Exhibit F attached to Docket Entry #280 in its entirety, # 2 Certificate of Service and Filing)(LASALA, JOSEPH) (Entered: 09/19/2008)
- 09/22/2008 292 ORDER on informal application sealing Exhibit F in it's entirety. Signed by Magistrate Judge Patty Shwartz on 09/19/2008. (nr, ) (Entered: 09/22/2008)
- 09/29/2008 -- CLERKS QUALITY CONTROL MESSAGE - The Motion Doc. 287 filed by JOSEPH LASALA on 9/17/2008 was submitted incorrectly as a Notice. PLEASE RESUBMIT THE MOTION USING MOTION. This submission will remain on the docket unless otherwise ordered by the court. (nr, ) (Entered: 09/29/2008)
- 09/29/2008 293 MOTION Rule 53(f) Objections and Motion to Modify Findings of Fact and Conclusions of Law of Special Master Dated September 4, 2008 (refiling of docket entry #287 pursuant to Clerk's Quality Control Message of 9/29/08) by NET2PHONE, INC.. (Attachments: # 1 Certification of Joseph La Sala, # 2 Certification of Joseph La Sala - Exhibit 1, # 3 Certification of Joseph La Sala - Exhibit 2, # 4 Brief (redacted) in Support of Plaintiff's Objections to the Special Master's Ruling on Privilege Log Entry 9072, # 5 Text of Proposed Order, # 6 Certificate of Service)(LASALA, JOSEPH) (Entered: 09/29/2008)
- 09/29/2008 -- Set Deadlines as to 293 MOTION Rule 53(f) Objections and Motion to Modify Findings of Fact and Conclusions of Law of Special Master Dated September 4, 2008 (refiling of docket entry #287 pursuant to Clerk's Quality Control Message of 9/29/08) MOTION Rule 53(f) Objections and Motion to Modify Findings of Fact and Conclusions of Law of Special Master Dated September 4, 2008. Motion Hearing set for 11/3/2008 10:00 AM before Judge Katharine S. Hayden. (PLEASE BE ADVISED THAT THIS MOTION WILL BE DECIDED ON THE PAPERS UNLESS OTHERWISE NOTIFIED BY THE COURT)(nr, ) (Entered: 10/01/2008)
- 10/03/2008 294 ORDER on informal application denying request to extend the deadlines associated with the preparation of the joint proposed final pretrial order; granting request to extend deadline to serve supplemental expert reports and to file motion for summary judgment. Signed by Magistrate Judge Patty Shwartz on 10/03/2008. (nr, ) (Entered: 10/06/2008)
- 10/07/2008 -- Minute Entry for proceedings held before Magistrate Judge Patty Shwartz: Telephone Conference held on 10/7/2008. (aa, ) (Entered: 10/08/2008)
- 10/08/2008 295 Letter from Thomas R. Curtin and Joseph LaSala requesting conference call. (CURTIN, THOMAS) (Entered: 10/08/2008)
- 10/08/2008 296 ORDER issuing a expedited briefing schedule. Signed by Judge Katharine S. Hayden on 10/8/08. (rg, ) (Entered: 10/08/2008)
- 10/09/2008 297 MOTION for Leave to File Supplemental Claim Construction Brief by EBAY, INC., SKYPE TECHNOLOGIES SA, SKYPE, INC.. (Attachments: # 1 Brief, # 2 Declaration of Benjamin Wang, # 3 Exhibit A to Wang Declaration (Redacted), # 4 Exhibit B to Wang Declaration (Redacted), # 5 Exhibit C to Wang Declaration (Redacted), # 6 Exhibit E to Wang Declaration (Redacted), # 7 Exhibit E to Wang Declaration, # 8 Exhibit F to Wang Declaration, # 9 Exhibit G to Wang Declaration (Redacted), # 10 Exhibit H to Wang Declaration (Redacted), # 11 Exhibit I to Wang Declaration, # 12 Exhibit J to Wang Declaration, # 13 Exhibit K to Wang Declaration, # 14 Exhibit L to Wang Declaration, # 15 Exhibit M to Wang Declaration, # 16 Exhibit N to Wang Declaration, # 17 Exhibit O to Wang Declaration, # 18 Text of Proposed Order, # 19 Certificate of Service)(CURTIN, THOMAS) (Entered: 10/09/2008)
- 10/09/2008 298 Exhibit to 297 Motion for Leave to File,,, by SKYPE TECHNOLOGIES SA, SKYPE, INC.. (Attachments: # 1 Exhibit B to Wang Declaration, # 2 Exhibit C to Wang Declaration, # 3 Exhibit D to Wang Declaration, # 4 Exhibit G to Wang Declaration, # 5 Exhibit H to Wang Declaration, # 6 Exhibit O to Wang Declaration, # 7 Brief in Support of Motion for Leave to File Supplemental Claim Construction Brief)(CURTIN, THOMAS) (Entered: 10/09/2008)
- 10/09/2008 299 MOTION to Seal by SKYPE TECHNOLOGIES SA, SKYPE, INC.. (Attachments: # 1 Brief in Support of Motion to Seal, # 2 Declaration of Kathleen N. Fennelly in Support of Motion to Seal, # 3 Text of Proposed Order Including Proposed Findings of Fact and Conclusions of Law, # 4 Certificate of Service)(CURTIN, THOMAS) (Entered: 10/09/2008)
- 10/09/2008 -- Set Deadlines as to 299 MOTION to Seal, 297 MOTION for Leave to File Supplemental Claim Construction Brief. Motion Hearing set for 11/3/2008 10:00 AM before Judge Katharine S. Hayden. (nr, ) (PLEASE BE ADVISED THAT THIS MOTION WILL BE DECIDED ON THE PAPERS UNLESS OTHERWISE NOTIFIED BY THE COURT) (Entered: 10/10/2008)
- 10/10/2008 300 MOTION for Reconsideration re 294 Order on Oral Motion, Rule 72 Objection to the Order of Magistrate Judge Patty Shwartz Regarding Extension of Filing Deadlines for the Final Joint Pretrial Order by NET2PHONE, INC.. (Attachments: # 1 Brief in Support of Objection, # 2 Certificate of Service, # 3 Text of Proposed Order, # 4 Text of Proposed Order for Alternate Relief)(LASALA, JOSEPH) (Entered: 10/10/2008)
- 10/10/2008 301 MOTION for Reconsideration re 294 Order on Oral Motion, 296 Order by EBAY, INC., SKYPE TECHNOLOGIES SA, SKYPE, INC.. (Attachments: # 1 Declaration of Alan J. Heinrich, # 2 Exhibit 1 to Heinrich Decl., # 3 Exhibit 2 to Heinrich Decl., # 4 Exhibit 3 to Heinrich Decl., # 5 Exhibit 4 to Heinrich Decl., # 6 Certificate of Service)(CURTIN, THOMAS) (Entered: 10/10/2008)
- 10/10/2008 302 Exhibit to 301 Motion for Reconsideration, by EBAY, INC., SKYPE TECHNOLOGIES SA, SKYPE, INC.. (CURTIN, THOMAS) (Entered: 10/11/2008)

- 10/10/2008 304 ORDER on informal application denying request for leave to serve a subpoena upon Kenyon & Kenyon for documents; granting request to reopen the deposition of Mr. Skelton, etc.. Signed by Magistrate Judge Patty Shwartz on 10/10/2008. (nr, ) (Entered: 10/14/2008)
- 10/10/2008 -- Set Deadlines as to 300 MOTION for Reconsideration re 294 Order on Oral Motion, Rule 72 Objection to the Order of Magistrate Judge Patty Shwartz Regarding Extension of Filing Deadlines for the Final Joint Pretrial Order MOTION for Reconsideration re 294 Order on Oral Motion, Rule 72 Objection to the Order of Magistrate Judge Patty Shwartz Regarding Extension of Filing Deadlines for the Final Joint Pretrial Order . Motion Hearing set for 11/3/2008 10:00 AM before Judge Katharine S. Hayden. (nr, )(PLEASE BE ADVISED THAT THIS MOTION WILL BE DECIDED ON THE PAPERS UNLESS OTHERWISE NOTIFIED BY THE COURT) (Entered: 10/14/2008)
- 10/11/2008 303 MOTION to Seal Document 302 Exhibit (to Document) by EBAY, INC., SKYPE TECHNOLOGIES SA, SKYPE, INC.. (Attachments: # 1 Brief, # 2 Declaration of Kathleen N. Fennelly, # 3 Text of Proposed Order, # 4 Certificate of Service)(CURTIN, THOMAS) (Entered: 10/11/2008)
- 10/14/2008 -- CLERKS QUALITY CONTROL MESSAGE - The BRIEF DOC. #301 filed by T. CURTIN on 10/10/2008 was submitted incorrectly as a MOTION. PLEASE RESUBMIT THE BRIEF USING RESPONSES AND REPLIES. This submission will remain on the docket unless otherwise ordered by the court. (nr, ) (Entered: 10/14/2008)
- 10/15/2008 305 BRIEF Defendants' Memorandum in Support of Parties' Expedited Appeal of Magistrate Judge Shwartz's October 3, 2008, Order filed by EBAY, INC., SKYPE TECHNOLOGIES SA, SKYPE, INC.. (CURTIN, THOMAS) (Entered: 10/15/2008)
- 10/20/2008 306 RESPONSE in Opposition re 297 MOTION for Leave to File Supplemental Claim Construction Brief filed by NET2PHONE, INC.. (Attachments: # 1 Certificate of Service, # 2 Text of Proposed Order, # 3 Text of Proposed Order Alternate Proposed Order)(LASALA, JOSEPH) (Entered: 10/20/2008)
- 10/20/2008 307 BRIEF Response to Plaintiff's Objection to the Special Master's Ruling on Privilege Log Entry 9072 filed by EBAY, INC., SKYPE TECHNOLOGIES SA, SKYPE, INC.. (Attachments: # 1 Declaration of Marko Kuo, # 2 Exhibit 1 to Kuo Decl., # 3 Exhibit 2 to Kuo Decl., # 4 Exhibit 3 to Kuo Decl. (Redacted), # 5 Exhibit 4 to Kuo Decl. (Redacted), # 6 Exhibit 5 to Kuo Decl. (Redacted), # 7 Certificate of Service)(CURTIN, THOMAS) (Entered: 10/20/2008)
- 10/20/2008 308 BRIEF Skype's Resopnse to Plaintiff's Objection to the Special Master's Ruling on Privilege Log Entry 9072 filed by SKYPE TECHNOLOGIES SA, SKYPE, INC.. (Attachments: # 1 Declaration of Marko Kuo, # 2 Exhibit 1 to Kuo Decl., # 3 Exhibit 2 to Kuo Decl., # 4 Exhibit 3 to Kuo Decl. (Redacted), # 5 Exhibit 4 to Kuo Decl. (Redacted), # 6 Exhibit 5 to Kuo Decl. (Redacted), # 7 Certificate of Service)(CURTIN, THOMAS) (Entered: 10/20/2008)
- 10/20/2008 309 BRIEF filed by EBAY, INC., SKYPE TECHNOLOGIES SA, SKYPE, INC.. (Attachments: # 1 Brief in Support of Skype's Response to Plaintiff's Objection to the Special Master's Ruling on Privilege Log Entry 9072 (Unredacted), # 2 Exhibit 3 to Kuo Decl. (Unredacted), # 3 Exhibit 4 to Kuo Decl. (Unredacted), # 4 Exhibit 5 to Kuo Decl. (Unredacted))(CURTIN, THOMAS) (Entered: 10/20/2008)
- 10/20/2008 310 MOTION to Seal by EBAY, INC., SKYPE TECHNOLOGIES SA, SKYPE, INC.. (Attachments: # 1 Brief in Support of Motion to Seal, # 2 Declaration of Kathleen N. Fennelly in Support of Motion to Seal, # 3 Text of Proposed Order to Seal Including Proposed Findings of Fact and Conclusions of Law, # 4 Certificate of Service)(CURTIN, THOMAS) (Entered: 10/20/2008)
- 10/22/2008 311 ORDER granting in part and denying in part 299 Motion to Seal certain portions of exhibits and directing the parties to submit by 10/30/2008 a redacted version of these documents. Signed by Magistrate Judge Patty Shwartz on 10/21/2008. (nr, ) (Entered: 10/22/2008)
- 10/27/2008 312 MOTION to Seal by NET2PHONE, INC.. (Attachments: # 1 Declaration J. LaSala, # 2 Brief motion to seal, # 3 Text of Proposed Order order to seal, # 4 Certificate of Service J. LaSala)(LASALA, JOSEPH) (Entered: 10/27/2008)
- 10/27/2008 313 REPLY BRIEF to Opposition to Motion re 253 APPEAL OF MAGISTRATE JUDGE DECISION to District Court by NET2PHONE, INC. re 247 Order on Oral Motion,, 312 MOTION to Seal filed by NET2PHONE, INC.. (Attachments: # 1 Brief Plaintiff's Reply in Further Support of its Objection to the Special Master's Ruling on Privilege Log No: 9072, # 2 Exhibit 1, # 3 Exhibit 2, # 4 Exhibit 3, # 5 Certificate of Service J. LaSala) (LASALA, JOSEPH) (Entered: 10/27/2008)
- 10/27/2008 314 BRIEF filed by EBAY, INC., SKYPE TECHNOLOGIES SA, SKYPE, INC.. (Attachments: # 1 Declaration of Benjamin Wang, # 2 Index A to Wang. Dec. (Redacted), # 3 Exhibit b, # 4 Exhibit C (Redacted), # 5 Exhibit D, # 6 Exhibit E (Redacted), # 7 Exhibit F (Redacted), # 8 Certificate of Service)(CURTIN, THOMAS) (Entered: 10/27/2008)
- 10/27/2008 -- Set Deadlines as to 312 MOTION to Seal. Motion set for 12/1/2008 10:00 AM before Judge Katharine S. Hayden. (nr, )(PLEASE BE ADVISED THAT THIS MOTION WILL BE DECIDED ON THE PAPERS UNLESS OTHERWISE NOTIFIED BY THE COURT) (Entered: 10/28/2008)
- 10/27/2008 317 OPINION & ORDER that the order of Magistrate Judge Shwartz dated 10/3/08 denying the parties' request to delay filing of certain portions of the joint proposed Final Pretrial Order is AFFIRMED; scheduling deadlines set forth by Magistrate Judge Shwartz shall remain intact, etc.. Signed by Judge Katharine S. Hayden on 10/27/08. (rg, ) (Entered: 10/29/2008)
- 10/28/2008 315 DECLARATION of Benjamin Wang in Support of Skype's Reply Brief in Support of Motion to File Supplemental Claim Construction Brief (With Unredacted Copies of Ex. A, C, E and F Attached)(Subject to Motion to Seal) re 314 Brief, by EBAY, INC., SKYPE TECHNOLOGIES SA, SKYPE, INC.. (Attachments: # 1 Exhibit A to Wang Decl.

(Unredacted), # 2 Exhibit B to Wang Decl., # 3 Exhibit C to Wang Decl. (Unredacted), # 4 Exhibit D to Wang Decl., # 5 Exhibit E to Wang Decl. (Unredacted), # 6 Exhibit F to Wang Decl. (Unredacted))(CURTIN, THOMAS) (Entered: 10/28/2008)

- 10/28/2008 316 MOTION to Seal Exhibits A, C, F and G to Declaration of Benjamin Wang In Support of Reply Brief in Support of Motion to File Supplemental Claim Construction Brief by EBAY, INC., SKYPE TECHNOLOGIES SA, SKYPE, INC.. (Attachments: # 1 Brief, # 2 Declaration of Kathleen N. Fennelly, # 3 Text of Proposed Order, # 4 Certificate of Service)(CURTIN, THOMAS) (Entered: 10/28/2008)
- 10/28/2008 -- Set Deadlines as to 316 MOTION to Seal Exhibits A, C, F and G to Declaration of Benjamin Wang In Support of Reply Brief in Support of Motion to File Supplemental Claim Construction Brief . Motion set for 12/1/2008 10:00 AM before Judge Katharine S. Hayden. (nr, ) (PLEASE BE ADVISED THAT THIS MOTION WILL BE DECIDED ON THE PAPERS UNLESS OTHERWISE NOTIFIED BY THE COURT) (Entered: 10/30/2008)
- 10/29/2008 318 ORDER that the unredacted version of Exhibit 1 to the Heinrich Declaration remain under seal. Signed by Judge Katharine S. Hayden on 10/21/2008. (nr, ) (Entered: 10/29/2008)
- 10/30/2008 319 DECLARATION of Benjamin Wang In Support of Motion to File Supplemental Claim Construction Brief (With Redacted Exhibits as Per D.E. 311) re 297 MOTION for Leave to File Supplemental Claim Construction Brief , 311 Order on Motion to Seal by EBAY, INC., SKYPE TECHNOLOGIES SA, SKYPE, INC.. (Attachments: # 1 Exhibit A to Wang Decl., # 2 Exhibit B to Wang Decl., # 3 Exhibit C to Wang Decl. (Redacted Pursuant to D.E. 311), # 4 Exhibit D to Wang Decl. (Redacted Pursuant to D.E. 311), # 5 Exhibit E to Wang Decl., # 6 Exhibit F to Wang Decl., # 7 Exhibit G to Wang Decl. (Redacted Pursuant to D.E. 311), # 8 Exhibit H to Wang Decl. (Redacted Pursuant to D.E. 311), # 9 Exhibit I to Wang Decl., # 10 Exhibit J to Wang Decl., # 11 Exhibit K to Wang Decl., # 12 Exhibit L to Wang Decl., # 13 Exhibit M to Wang Decl., # 14 Exhibit N to Wang Decl., # 15 Exhibit O to Wang Decl. (Redacted Pursuant to D.E. 311))(FENNELLY, KATHLEEN) (Entered: 10/30/2008)
- 10/31/2008 324 Transcript of Proceedings held on October 10, 2008, before Judge Shwartz. Court Reporter/Transcriber King Transcription. (ji, ) Modified on 11/7/2008 (ji, ). (Entered: 11/06/2008)
- 11/03/2008 320 ORDER granting in part and denying in part 316 Motion to Seal certain documents; directing the deft. to file on public docket a version of these items redacted no later than 11/7/2008. Signed by Magistrate Judge Patty Shwartz on 10/31/2008. (nr, ) (Entered: 11/05/2008)
- 11/05/2008 321 NOTICE of Appearance by GEORGE C. JONES on behalf of EBAY, INC., SKYPE TECHNOLOGIES SA, SKYPE, INC. (JONES, GEORGE) (Entered: 11/05/2008)
- 11/05/2008 322 AMENDED DOCUMENT by NET2PHONE, INC.. Amendment to 260 Order on Motion for Leave to File. (Attachments: # 1 Certificate of Service)(LASALA, JOSEPH) (Entered: 11/05/2008)
- 11/05/2008 323 AMENDED DOCUMENT by NET2PHONE, INC.. Amendment to 322 Amended Document Amended Certification of Service . (LASALA, JOSEPH) (Entered: 11/05/2008)
- 11/05/2008 325 ORDER granting in part and denying in part 310 Motion to Seal; denying 312 Motion to Seal; denying 289 Motion to Seal; denying 293 Motion objection to Special Master's ruling and adopting the Special Master's decision; directing the parties to produce no later than 11/10/2008 a redacted version of these documents. Signed by Magistrate Judge Patty Shwartz on 11/03/2008. (nr, ) (Entered: 11/06/2008)
- 11/06/2008 326 DECLARATION of Benjamin Wang in Support of Skype's Reply Brief in Support of Motion to File Supplemental Claim Construction Brief (with redacted and unredacted exhibits per D.E. 320) re 314 Brief, 320 Order on Motion to Seal, 297 MOTION for Leave to File Supplemental Claim Construction Brief by EBAY, INC., SKYPE TECHNOLOGIES SA, SKYPE, INC.. (Attachments: # 1 Exhibit A to Wang Declaration (Unredacted per D.E. 320), # 2 Exhibit B to Wang Declaration, # 3 Exhibit C to Wang Declaration (Unredacted per D.E. 320), # 4 Exhibit D to Wang Declaration, # 5 Exhibit E to Wang Declaration (Redacted per D.E. 320), # 6 Exhibit F to Wang Declaration (Redacted per D.E. 320))(JONES, GEORGE) (Entered: 11/06/2008)
- 11/07/2008 -- Minute Entry for proceedings held before Magistrate Judge Patty Shwartz: Final Pretrial Conference held on the record on 11/7/2008. (CD #S08-23.) (aa, ) (Entered: 11/30/2008)
- 11/10/2008 327 MOTION for Leave to Appear Pro Hac Vice on Behalf of Joseph M. Drayton, Esq., Vandana Koelsch, Esq., Kevin Jakel, Esq. and Gillian T. DiFilippo, Esq. by NET2PHONE, INC.. (Attachments: # 1 Affidavit of Joseph M. Drayton, Esq., # 2 Affidavit of Vandana Koelsch, Esq., # 3 Affidavit of Kevin Jakel, Esq., # 4 Affidavit of Gillian T. DiFilippo, Esq., # 5 Affidavit of Joseph P. La Sala, Esq., # 6 Text of Proposed Order, # 7 Certificate of Service)(LASALA, JOSEPH) (Entered: 11/10/2008)
- 11/10/2008 328 ORDER on informal application directing the parties to submit their revisions to the portions of the revised joint proposed final pretrial order; Proposed Pretrial Order due on 12/9/2008. granting request to depose Mr. Skelton and granting request to allow Professor Maggs and Professor Johnson to supplement expert reports Signed by Magistrate Judge Patty Shwartz on 11/7/2008. (nr, ) (Entered: 11/13/2008)
- 11/12/2008 329 ORDER granting 327 Motion for Joseph M. Drayton, Vandana Koelsch, Kevin Jakel, and Gillian T. DiFilippo to Appear Pro Hac Vice. Signed by Magistrate Judge Patty Shwartz on 11/12/2008. (nr, ) Modified on 11/14/2008 (nr, ). (Entered: 11/14/2008)
- 11/14/2008 330 Notice of Request by Pro Hac Vice Joseph M. Drayton, Esq. to receive Notices of Electronic Filings. ( Pro Hac Vice fee \$ 150 receipt number 0312000000002271582.) (LASALA, JOSEPH) (Entered: 11/14/2008)
- 11/14/2008 331 Notice of Request by Pro Hac Vice Vandana Koelsch, Esq. to receive Notices of Electronic Filings. ( Pro Hac Vice fee \$ 150 receipt number 0312000000002271590.) (LASALA, JOSEPH) (Entered: 11/14/2008)
- 11/14/2008 332 Notice of Request by Pro Hac Vice Kevin Jakel, Esq. to receive Notices of Electronic Filings. ( Pro Hac Vice fee \$

- 150 receipt number 0312000000002271599.) (LASALA, JOSEPH) (Entered: 11/14/2008)
- 11/14/2008 333 Notice of Request by Pro Hac Vice Gillian T. DiFilippo, Esq. to receive Notices of Electronic Filings. ( Pro Hac Vice fee \$ 150 receipt number 0312000000002271610.) (LASALA, JOSEPH) (Entered: 11/14/2008)
- 11/17/2008 334 Transcript of Proceedings (Volume I) held on 11/3/2008, before Judge Patty Shwartz. Court Reporter/Transcriber King Transcription Services, Telephone number 973 237-6080. NOTICE REGARDING REDACTION OF TRANSCRIPTS: The parties have seven (7) calendar days to file with the Court a Notice of Intent to Request Redaction of this Transcript. If no such notice is filed, the transcript will be made remotely available in electronic format to the public without redaction after ninety(90) calendar days. The redaction policy is located on our website at www.njd.uscourts.gov. Transcripts may be viewed at the court public terminal or purchased through the Court Reporter/Transcriber before the deadline for release of transcript restriction. After that date it may be obtained through PACER. Redaction Request due 12/8/2008. Redacted Transcript Deadline set for 12/18/2008. Release of Transcript Restriction set for 2/15/2009. (mn, ) (Entered: 11/17/2008)
- 11/24/2008 335 Letter from Kathleen N. Fennelly (Joint Letter) Regarding Markman Hearing Schedule. (FENNELLY, KATHLEEN) (Entered: 11/24/2008)
- 12/03/2008 336 SCHEDULING ORDER: Status Conference in person set for 12/10/2008 10:00 AM before Judge Katharine S. Hayden.. Signed by Judge Katharine S. Hayden on 12/3/08. (rg, ) (Entered: 12/03/2008)
- 12/10/2008 -- Minute Entry for proceedings held before Judge Katharine S. Hayden: Status Conference held on 12/10/2008; scheduling order to issue. (rg, ) (Entered: 12/10/2008)
- 12/12/2008 337 ORDER setting a Markman Hearing for 3/2/2009 10:00 AM.. Signed by Judge Katharine S. Hayden on 12/10/2008. (nr, ) (Entered: 12/12/2008)
- 01/05/2009 338 NOTICE by NET2PHONE, INC. of change of firm name from Grayson & Kubli, P.C. to Kubli & Associates, P.C. (Attachments: # 1 Certificate of Service)(LASALA, JOSEPH) (Entered: 01/05/2009)
- 01/05/2009 339 NOTICE by NET2PHONE, INC. re 273 Notice of Pro Hac Vice to Receive NEF Notice of Withdrawal of Pro Hac Vice Attorney Alan M. Grayson, Esq. (Attachments: # 1 Certificate of Service)(LASALA, JOSEPH) (Entered: 01/05/2009)
- 01/09/2009 340 Letter from Joseph P. La Sala, Esq. regarding change of contact information for pro hac vice attorneys re 338 Notice (Other). (LASALA, JOSEPH) (Entered: 01/09/2009)
- 01/14/2009 341 FINAL PRETRIAL ORDER. Signed by Magistrate Judge Patty Shwartz on 12/11/2008. (Attachments: # 1 Cont. of Pretrial Order, # 2 Cont. of Pretrial Order, # 3 Cont. of Pretrial Order, # 4 Cont. of Pretrial Order, # 5 Cont. of Pretrial Order)(nr, ) (Entered: 01/14/2009)
- 02/06/2009 342 ORDER on informal application granting def't's request to strike the Oct. 10,2009 "supplemental" report of Kevin Jaffay and "rebuttal" reports of Matthew Lynde and Samrat Bhattacharjee. Signed by Magistrate Judge Patty Shwartz on 02/05/2009. (nr, ) (Entered: 02/09/2009)
- 02/11/2009 343 Transcript of Proceedings (Opinion) held on 2/5/2009, before Judge Patty Shwartz. Court Reporter/Transcriber King Transcription Services, Telephone number 973 237-6080. NOTICE REGARDING REDACTION OF TRANSCRIPTS: The parties have seven (7) calendar days to file with the Court a Notice of Intent to Request Redaction of this Transcript. If no such notice is filed, the transcript will be made remotely available in electronic format to the public without redaction after ninety(90) calendar days. The redaction policy is located on our website at www.njd.uscourts.gov. Transcripts may be viewed at the court public terminal or purchased through the Court Reporter/Transcriber before the deadline for release of transcript restriction. After that date it may be obtained through PACER. Redaction Request due 3/4/2009. Redacted Transcript Deadline set for 3/16/2009. Release of Transcript Restriction set for 5/12/2009. (mn, ) (Entered: 02/17/2009)
- 02/20/2009 344 Letter from Joseph La Sala. (LASALA, JOSEPH) (Entered: 02/20/2009)
- 02/23/2009 345 LETTER ORDER granting Net2Phone's request for a two week extension of time to file objection to Mag. Judge Shwartz's order dated 2/5/2009. Signed by Judge Katharine S. Hayden on 02/20/2009. (nr, ) (Entered: 02/24/2009)
- 02/26/2009 346 Letter from Thomas R. Curtin, Esq.. (CURTIN, THOMAS) (Entered: 02/26/2009)
- 02/26/2009 347 STATEMENT Joint Claim Construction Statement by NET2PHONE, INC.. (Attachments: # 1 Certificate of Service)(LASALA, JOSEPH) (Entered: 02/27/2009)
- 02/27/2009 348 Letter from Joseph P. LaSala. (LASALA, JOSEPH) (Entered: 02/27/2009)
- 02/27/2009 349 Letter from Joseph P. LaSala. (LASALA, JOSEPH) (Entered: 02/27/2009)
- 03/03/2009 350 ORDER denying Mag. appeal of pltf's objection to the order of Mag. Judge Shwartz to the extent it raised an objection under Rule 60(f) of the FRCP; and remanding this matter to Mag. Judge Patty Shwartz for the limited purpose of supplementing her fee award decision. Signed by Judge Katharine S. Hayden on 03/03/2009. (nr, ) (Entered: 03/04/2009)
- 03/10/2009 351 APPEAL OF MAGISTRATE JUDGE DECISION to District Court by NET2PHONE, INC. re 342 Order on Oral Motion, (Attachments: # 1 Brief in Support of Rule 72 Objection, # 2 Declaration Joseph P. LaSala, # 3 Exhibit 1, # 4 Exhibit 2, # 5 Exhibit 3, # 6 Exhibit 4, # 7 Exhibit 5, # 8 Text of Proposed Order, # 9 Certificate of Service) (LASALA, JOSEPH) (Entered: 03/10/2009)
- 03/10/2009 -- Set Deadlines as to 351 APPEAL OF MAGISTRATE JUDGE DECISION to District Court by NET2PHONE, INC. re



- 342 Order on Oral Motion, APPEAL OF MAGISTRATE JUDGE DECISION to District Court by NET2PHONE, INC. re 342 Order on Oral Motion,. Motion set for 4/6/2009 10:00 AM before Judge Katharine S. Hayden. The motion will be decided on the papers. No appearances required unless notified by the court. (nr, ) (Entered: 03/13/2009)
- 03/12/2009 352 MOTION to Stay Litigation Pending Reexamination of the Patents-In-Suit by the Patent and Trademark Office by EBAY, INC., SKYPE TECHNOLOGIES SA, SKYPE, INC.. (Attachments: # 1 Brief, # 2 Declaration of Benjamin Wang, # 3 Exhibit A to Wang Decl., # 4 Exhibit B (Part 1) to Wang Declaration, # 5 Exhibit B (Part 2) to Wang Declaration, # 6 Exhibit B (Part 3) to Wang Decl., # 7 Exhibit C to Wang Decl., # 8 Exhibit D to Wang Decl., # 9 Exhibit E to Wang Decl., # 10 Exhibit F to Wang Decl., # 11 Exhibit G to Wang Decl., # 12 Exhibit H to Wang Decl., # 13 Exhibit I to Wang Decl., # 14 Exhibit J to Wang Decl., # 15 Exhibit K to Wang Decl., # 16 Exhibit L to Wang Decl., # 17 Exhibit M to Wang Decl., # 18 Exhibit N to Wang Decl., # 19 Text of Proposed Order, # 20 Certificate of Service)(CURTIN, THOMAS) (Entered: 03/12/2009)
- 03/12/2009 353 Exhibit to 352 Motion to Stay,,, by SKYPE TECHNOLOGIES SA, SKYPE, INC.. (Attachments: # 1 Brief Unredacted Brief in Support of Motion to Stay)(CURTIN, THOMAS) (Entered: 03/12/2009)
- 03/12/2009 354 MOTION to Seal Case by EBAY, INC., SKYPE TECHNOLOGIES SA, SKYPE, INC.. (Attachments: # 1 Brief in Support of Motion to Seal, # 2 Declaration of Kathleen N. Fennelly in Support of Motion to Seal, # 3 Text of Proposed Order, # 4 Certificate of Service)(CURTIN, THOMAS) (Entered: 03/12/2009)
- 03/12/2009 -- Set Deadlines as to 352 MOTION to Stay Litigation Pending Reexamination of the Patents-In-Suit by the Patent and Trademark Office , 354 MOTION to Seal Case. Motion set for 4/6/2009 10:00 AM before Judge Katharine S. Hayden. The motion will be decided on the papers. No appearances required unless notified by the court. (nr, ) (Entered: 03/17/2009)
- 03/17/2009 355 BRIEF Supplemental Brief in Support of Mot on to Stay Litigation Pending Reexamination of the Patents-In-Suit by the Patent and Trademark Office filed by EBAY, INC., SKYPE TECHNOLOGIES SA, SKYPE, INC.. (Attachments: # 1 Declaration of Benjamin Wang in Support of Supplemental Brief, # 2 Exhibit A to Wang Decl. in Support of Supplemental Brief, # 3 Exhibit B to Wang Decl. in Support of Supplemental Brief, # 4 Exhibit C to Wang Decl. in Support of Supplemental Brief, # 5 Exhibit D to Wang Decl. in Support of Supplemental Brief, # 6 Exhibit E to Wang Decl. in Support of Supplemental Brief, # 7 Certificate of Service) (CURTIN, THOMAS) (Entered: 03/17/2009)
- 03/17/2009 356 Notice to be terminated and withdraw from Notices of Electronic filing as to case. (FENNELLY, KATHLEEN) (Entered: 03/17/2009)
- 03/17/2009 357 Notice to be terminated and withdraw from Notices of Electronic filing as to case. (FENNELLY, KATHLEEN) (Entered: 03/17/2009)
- 03/18/2009 358 ORDER discharging the special Master as mediator. Signed by Magistrate Judge Patty Shwartz on 03/13/2009. (nr, ) (Entered: 03/19/2009)
- 03/18/2009 359 ORDER granting in part and denying in part 354 Motion to Seal Case. Signed by Magistrate Judge Patty Shwartz on 03/18/2009. (nr, ) (Entered: 03/19/2009)
- 03/19/2009 360 Letter from Joseph LaSala. (LASALA, JOSEPH) (Entered: 03/19/2009)
- 03/20/2009 361 ORDER filed. Signed by Judge Katharine S. Hayden on 3/20/09. (rg, ) (Entered: 03/20/2009)
- 03/20/2009 362 Letter from Thomas R. Curtin. (FENNELLY, KATHLEEN) (Entered: 03/20/2009)
- 03/23/2009 363 BRIEF in Response to Plaintiff's Objection to Magistrate Judge Shwartz's Order Striking Plaintiff's October Expert Reports filed by EBAY, INC., SKYPE TECHNOLOGIES SA, SKYPE, INC.. (Attachments: # 1 Declaration of Marko Kuo, # 2 Exhibit 1 to Kuo Declaration, # 3 Exhibit 2 to Kuo Declaration, # 4 Exhibit 3 to Kuo Declaration, # 5 Certificate of Service)(CURTIN, THOMAS) (Entered: 03/23/2009)
- 03/25/2009 364 ORDER denying request for an award of attorneys fees. Signed by Magistrate Judge Patty Shwartz on 03/25/2009. (nr, ) Modified on 3/26/2009 (nr, ). (Entered: 03/26/2009)
- 03/26/2009 366 ORDER granting defts. request for an extension of time to file reply to pltf's opposition until 4/20/2009 and setting oral argument on motion to stay for 5/13/2009 at 10:00a.m.. Signed by Judge Katharine S. Hayden on 03/24/2009. (nr, ) (Entered: 03/27/2009)
- 03/27/2009 365 Letter from Joseph P. La Sala. (LASALA, JOSEPH) (Entered: 03/27/2009)
- 03/27/2009 367 AMENDED DOCUMENT by EBAY, INC., SKYPE TECHNOLOGIES SA, SKYPE, INC.. Amendment to 359 Order on Motion to Seal Case, 352 MOTION to Stay Litigation Pending Reexamination of the Patents-In-Suit by the Patent and Trademark Office Redacted Brief in Support of Motion to Stay as Per D.E.359 . (Attachments: # 1 Exhibit F (Redacted Pursuant to D.E. 359) to Declaration of Benjamin Wang in Support of Skype's Motion to Stay Litigation)(FENNELLY, KATHLEEN) (Entered: 03/27/2009)
- 04/06/2009 368 MOTION to Seal by NET2PHONE, INC.. (Attachments: # 1 Brief In Support of Motion to Seal, # 2 Certification of Joseph LaSala in Support of Motion to Seal, # 3 Text of Proposed Order, # 4 Certificate of Service)(LASALA, JOSEPH) (Entered: 04/06/2009)
- 04/06/2009 369 BRIEF in Opposition re 352 MOTION to Stay Litigation Pending Reexamination of the Patents-In-Suit by the Patent and Trademark Office filed by NET2PHONE, INC.. (Attachments: # 1 Declaration of Liore Alroy in Support of Net2Phone's Opposition Brief, # 2 Certification of Joseph LaSala in Support of Net2Phone's Opposition Brief, # 3 Exhibit 1, # 4 Exhibit 2, # 5 Exhibit 3A, # 6 Exhibit 3B, # 7 Exhibit 4, # 8 Exhibit 5, # 9 Exhibit 6, # 10 Exhibit 7, # 11 Exhibit 8, # 12 Exhibit 9, # 13 Exhibit 10, # 14 Exhibit 11, # 15 Exhibit 12, #

- 16 Exhibit 13, # 17 Exhibit 14, # 18 Exhibit 15, # 19 Exhibit 16, # 20 Exhibit 17, # 21 Exhibit 18, # 22 Exhibit 19, # 23 Exhibit 20, # 24 Exhibit 21, # 25 Exhibit 22, # 26 Text of Proposed Order, # 27 Certificate of Service)(LASALA, JOSEPH) (Entered: 04/06/2009)
- 04/06/2009 -- Set Deadlines as to 368 MOTION to Seal. Motion set for 5/4/2009 10:00 AM before Judge Katharine S. Hayden. The motion will be decided on the papers. No appearances required unless notified by the court. (nr, ) (Entered: 04/08/2009)
- 04/14/2009 370 Letter from Joseph La Sala. (LASALA, JOSEPH) (Entered: 04/14/2009)
- 04/14/2009 371 ORDER granting in part and denying in part 368 Motion to Seal; directing the pltf. to file no later than 4/22/2009 qa readacted version. Signed by Magistrate Judge Patty Shwartz on 04/13/2009. (nr, ) (Entered: 04/14/2009)
- 04/15/2009 372 ORDER denying letter request dated April 13, 2009. Signed by Judge Katharine S. Hayden on 4/14/09. (rg, ) (Entered: 04/15/2009)
- 04/16/2009 373 Letter from Joseph P. La Sala, Esq. re: Net2Phone, Inc. v. eBay, Inc., et als.. (LASALA, JOSEPH) (Entered: 04/16/2009)
- 04/20/2009 374 BRIEF Reply Brief in Support of Motion to Stay Litigation Pending Reexamination of the Patents-In-Suit by the Patent and Trademark Office filed by EBAY, INC., SKYPE TECHNOLOGIES SA, SKYPE, INC.. (Attachments: # 1 Declaration of Lissi Mojica, # 2 Exhibit A to Mojica Decl., # 3 Exhibit B to Mojica Decl., # 4 Exhibit C to Mojica Decl., # 5 Declaration of Benjamin Wang, # 6 Exhibit A to Wang Decl., # 7 Exhibit B to Wang Decl., # 8 Exhibit C to Wang Decl. (Redacted), # 9 Exhibit D to Wang Decl. (Redacted), # 10 Exhibit E to Wang Decl., # 11 Exhibit F to Wang Decl., # 12 Exhibit G to Wang Decl. (Redacted), # 13 Exhibit H to Wang Decl. (Redacted), # 14 Exhibit I to Wang Decl. (Redacted), # 15 Exhibit J to Wang Decl. (Redacted), # 16 Exhibit K to Wang Decl. (Redacted), # 17 Exhibit L to Wang Decl. (Redacted), # 18 Exhibit M to Wang Decl. (Redacted), # 19 Exhibit N to Wang Decl., # 20 Exhibit O to Wang Decl., # 21 Exhibit P to Wang Decl., # 22 Exhibit Q to Wang Decl., # 23 Exhibit R to Wang Decl. (Redacted), # 24 Certificate of Service)(CURTIN, THOMAS) (Entered: 04/20/2009)
- 04/20/2009 375 REPLY BRIEF to Opposition to Motion re 352 MOTION to Stay Litigation Pending Reexamination of the Patents-In-Suit by the Patent and Trademark Office (Unredacted Reply Brief) filed by EBAY, INC., SKYPE TECHNOLOGIES SA, SKYPE, INC.. (Attachments: # 1 Exhibit C To Wang Decl. (Unredacted), # 2 Exhibit D to Wang Decl. (Unredacted), # 3 Exhibit G to Wang Decl. (Unredacted), # 4 Exhibit H to Wang Decl. (Unredacted), # 5 Exhibit I to Wang Decl. (Unredacted), # 6 Exhibit J to Wang Decl. (Unredacted), # 7 Exhibit K to Wang Decl. (Unredacted), # 8 Exhibit L to Wang Decl. (Unredacted), # 9 Exhibit M to Wang Decl. (Unredacted), # 10 Exhibit R to Wang Decl. (Unredacted))(CURTIN, THOMAS) (Entered: 04/20/2009)
- 04/20/2009 376 MOTION to Seal by EBAY, INC., SKYPE TECHNOLOGIES SA, SKYPE, INC.. (Attachments: # 1 Brief in Support of Motion to Seal, # 2 Declaration of Kathleen N. Fennelly in Support of Motion to Seal, # 3 Text of Proposed Order, # 4 Certificate of Service)(CURTIN, THOMAS) (Entered: 04/20/2009)
- 04/20/2009 377 Minute Entry for proceedings held before Judge Katharine S. Hayden: Settlement Conference held on 4/20/2009. (rg, ) (Entered: 04/21/2009)
- 04/20/2009 -- Set Deadlines as to 376 MOTION to Seal. Motion set for 5/18/2009 10:00 AM before Judge Katharine S. Hayden. The motion will be decided on the papers. No appearances required unless notified by the court. (nr, ) (Entered: 04/21/2009)
- 04/22/2009 378 CERTIFICATION in Opposition re 352 MOTION to Stay Litigation Pending Reexamination of the Patents-In-Suit by the Patent and Trademark Office (with redacted, unredacted, and sealed exhibits per D.E. 371) filed by NET2PHONE, INC.. (Attachments: # 1 Exhibit 1, # 2 Exhibit 2, # 3 Exhibit 3A, # 4 Exhibit 3B, # 5 Exhibit 4, # 6 Exhibit 5, # 7 Exhibit 6, # 8 Exhibit 7, # 9 Exhibit 8, # 10 Exhibit 9, # 11 Exhibit 10 (Sealed), # 12 Exhibit 11 (Sealed), # 13 Exhibit 12 (Sealed), # 14 Exhibit 14, # 15 Exhibit 15 (Redacted), # 16 Exhibit 16 (Redacted), # 17 Exhibit 17 (Redacted), # 18 Exhibit 18, # 19 Exhibit 19, # 20 Exhibit 20, # 21 Exhibit 21, # 22 Exhibit 22, # 23 Exhibit 13)(LASALA, JOSEPH) (Entered: 04/22/2009)
- 04/22/2009 379 Exhibit to 378 Certification in Opposition to Motion,,, by NET2PHONE, INC.. (LASALA, JOSEPH) (Entered: 04/22/2009)
- 04/24/2009 380 Letter from Joseph La Sala Re: Net2Phone, Inc. v. eBay Inc. et al. (LASALA, JOSEPH) (Entered: 04/24/2009)
- 04/24/2009 381 ORDER granting in part and denying in part 376 Motion to Seal certain portions of a brief and exhibit. Signed by Magistrate Judge Patty Shwartz on 04/24/2009. (nr, ) (Entered: 04/27/2009)
- 04/27/2009 -- TEXTED ORDER: The parties are directed to cooperate with the Hon. Alfred M. Wolin (ret.), entered by Judge Katharine S. Hayden on 4/27/09. (rg, ) (Entered: 04/27/2009)
- 04/28/2009 -- TEXT ORDER: Counsel are advised that the previously scheduled 5/13/09 oral argument on the pending motion to stay is rescheduled to 7/1/09 at 10:00 a.m. entered by Judge Katharine S. Hayden on 4/28/09. (rg, ) (Entered: 04/28/2009)
- 04/30/2009 382 REPLY BRIEF to Opposition to Motion re 352 MOTION to Stay Litigation Pending Reexamination of the Patents-In-Suit by the Patent and Trademark Office (Redacted as Per Court Order) filed by EBAY, INC., SKYPE TECHNOLOGIES SA, SKYPE, INC.. (Attachments: # 1 Declaration of Benjamin Wang (with exhibits redacted as per court order), # 2 Exhibit A to Wang Declaration, # 3 Exhibit B to Wang Declaration, # 4 Exhibit C to Wang Declaration, # 5 Exhibit D to Wang Declaration, # 6 Exhibit E to Wang Declaration, # 7 Exhibit F to Wang Declaration, # 8 Exhibit G to Wang Declaration, # 9 Exhibit H to Wang Declaration, # 10 Exhibit I to Wang

- Declaration, # 11 Exhibit J to Wang Declaration, # 12 Exhibit K to Wang Declaration, # 13 Exhibit L to Wang Declaration, # 14 Exhibit M to Wang Declaration, # 15 Exhibit N to Wang Declaration, # 16 Exhibit O to Wang Declaration, # 17 Exhibit P to Wang Declaration, # 18 Exhibit Q to Wang Declaration, # 19 Exhibit R to Wang Declaration)(FENNELLY, KATHLEEN) (Entered: 04/30/2009)
- 05/06/2009 383 SUPPLEMENTAL ORDER sealing the Wang Declaration exhibit G. Signed by Magistrate Judge Patty Shwartz on 04/28/2009. (nr, ) (Entered: 05/06/2009)
- 06/17/2009 -- TEXT ORDER: Counsel are advised that the previously scheduled oral argument date of July 1, 2009 is rescheduled to July 21, 2009 at 11:00 a.m. as to (352) MOTION to Stay before Judge Katharine S. Hayden, entered by Judge Katharine S. Hayden on 6/17/09. (rg, ) (Entered: 06/17/2009)
- 07/01/2009 384 ORDER denying 352 Motion to Stay. Signed by Judge Katharine S. Hayden on 7/1/09. (rg, ) (Entered: 07/01/2009)
- 07/01/2009 -- TEXT ORDER: Counsel are advised that the previously scheduled hearing on the motion to stay set for July 21, 2009 is cancelled; Markman hearing is scheduled for 9/16/2009 09:30 AM; Counsel are required to confirm attendance for this hearing via letter filed on the Court's docket, entered by Judge Katharine S. Hayden on 7/1/09. (rg, ) (Entered: 07/01/2009)
- 07/23/2009 385 Letter from Thomas R. Curtin Regarding Markman Hearing. (CURTIN, THOMAS) (Entered: 07/23/2009)
- 07/28/2009 386 LETTER ORDER granting the parties request to adjourn Markman Hrg. to 10/27/2009 at 10:00a.m.. Signed by Judge Katharine S. Hayden on 07/27/2009. (nr, ) (Entered: 07/29/2009)
- 08/12/2009 387 OPINION AND ORDER denying 351 Appeal Magistrate Judge Decision to District Court;. Signed by Judge Katharine S. Hayden on 08/10/2009. (nr, ) (Entered: 08/12/2009)
- 10/23/2009 388 STIPULATION AND ORDER granting request to extend case deadlines for 120 days, including the Markman hrg. scheduled for 10/27/2009; etc.. Signed by Judge Katharine S. Hayden on 10/23/2009. (nr, ) (Entered: 10/26/2009)
- 01/07/2010 389 Certification on behalf of NET2PHONE, INC. Re Set/Reset Motion and R&R Deadlines/Hearings,. (Attachments: # 1 Certificate of Service, # 2 Exhibit A - Part I, # 3 Exhibit A - Part II, # 4 Exhibit A - Part III, # 5 Exhibit A - Part IV)(LASALA, JOSEPH) (Entered: 01/07/2010)
- 01/08/2010 -- CLERK'S QUALITY CONTROL MESSAGE: KEVIN JAKEL, does not have a correct e-mail address listed with the court and is not receiving his/her notices of electronic filing in this case. Pursuant to local rule 10.1 and court procedures, counsel and unrepresented parties are required to notify the court of any mailing or e-mail address changes. The court has deleted the invalid e-mail address. Attorneys should review the ECF link on our web site for information on maintaining your account and unrepresented parties, or those attorneys without access to maintaining their account, should notice the Clerk. (sa, ) (Entered: 01/08/2010)
- 01/12/2010 390 NOTICE by NET2PHONE, INC. Notice of Withdrawal of Admission Pro Hac Vice of Kevin Jakel, Esq. and Gillian T. DiFilippo, Esq. (Attachments: # 1 Certificate of Service)(LASALA, JOSEPH) (Entered: 01/12/2010)
- 01/14/2010 391 MOTION for Leave to Appear Pro Hac Vice of Howard B. Miller, Esq., Stephen G. Larson, Esq., and Graham B. Lippsmith, Esq. by NET2PHONE, INC.. (Attachments: # 1 Certificate of Service, # 2 Affidavit, # 3 Affidavit, # 4 Affidavit, # 5 Affidavit, # 6 Text of Proposed Order)(LASALA, JOSEPH) (Entered: 01/14/2010)
- 01/14/2010 392 NOTICE of Appearance by JOSEPH P. LASALA on behalf of NET2PHONE, INC. (Attachments: # 1 Certificate of Service)(LASALA, JOSEPH) (Entered: 01/14/2010)
- 01/14/2010 -- Set Deadlines as to 391 MOTION for Leave to Appear Pro Hac Vice of Howard B. Miller, Esq., Stephen G. Larson, Esq., and Graham B. Lippsmith, Esq. . Motion set for 2/16/2010 10:00 AM before Judge Katharine S. Hayden. The motion will be decided on the papers. No appearances required unless notified by the court. (nr, ) (Entered: 01/17/2010)
- 02/10/2010 393 Amended MOTION for Leave to Appear Pro Hac Vice by NET2PHONE, INC.. (Attachments: # 1 Certificate of Service, # 2 Letter to The Honorable Patty Shwartz, U.S.M.J., # 3 Certification of Joseph P. LaSala, Esq., # 4 Affidavits of Howard B. Miller, Esq., Stephen G. Larson, Esq., and Graham B. LippSmith, Esq., # 5 Text of Proposed Order)(LASALA, JOSEPH) (Entered: 02/10/2010)
- 02/10/2010 -- Set Deadlines as to 393 Amended MOTION for Leave to Appear Pro Hac Vice. Motion set for 3/15/2010 10:00 AM before Judge Katharine S. Hayden. The motion will be decided on the papers. No appearances required unless notified by the court. (nr, ) (Entered: 02/14/2010)
- 02/11/2010 394 Letter from Thomas R. Curtin re 393 Amended MOTION for Leave to Appear Pro Hac Vice. (CURTIN, THOMAS) (Entered: 02/11/2010)
- 02/11/2010 396 ORDER granting 391 & (393) Motion for Howard B. Miller, Stephen G. Larson and Graham B. Lippsmith to Appear Pro Hac Vice;. Signed by Magistrate Judge Patty Shwartz on 02/11/2010. (nr, ) (Entered: 02/16/2010)
- 02/12/2010 395 Letter from Joseph P. LaSala, Esq. re 393 Amended MOTION for Leave to Appear Pro Hac Vice, 394 Letter. (LASALA, JOSEPH) (Entered: 02/12/2010)
- 02/16/2010 397 NOTICE by NET2PHONE, INC. NOTICE OF WITHDRAWAL OF ADMISSION PRO HAC VICE OF ALAN M. FISCH, ESQ., COKE MORGAN STEWART, ESQ., JOSEPH M. DRAYTON, ESQ., AND VANDANA KOELSCH, ESQ. (Attachments: # 1 Certificate of Service)(LASALA, JOSEPH) (Entered: 02/16/2010)
- 02/17/2010 -- CLERK'S QUALITY CONTROL MESSAGE: MARKO KUO, does not have a correct e-mail address listed with the court and is not receiving his/her notices of electronic filing in this case. Pursuant to local rule 10.1 and court

procedures, counsel and unrepresented parties are required to notify the court of any mailing or e-mail address changes. The court has deleted the invalid e-mail address. Attorneys should review the ECF link on our web site for information on maintaining your account and unrepresented parties, or those attorneys without access to maintaining their account, should notice the Clerk. (sa, ) (Entered: 02/17/2010)

- 02/25/2010 -- Pro Hac Vice fee: \$ 450., receipt number 200360187 re Howard Miller/Stephen Larson/Graham Lippsmith (nr, ) (Entered: 02/25/2010)
- 03/02/2010 398 NOTICE by MARKO KUO of Withdrawal of Pro Hac Vice Admission (FENNELLY, KATHLEEN) (Entered: 03/02/2010)
- 03/15/2010 399 Letter from Victor A. Kubli, Esq. of Kubli & Associates, P.C.. (LASALA, JOSEPH) (Entered: 03/15/2010)
- 03/16/2010 400 LETTER ORDER granting pltf's request to extend their time to submit a final report by 5/15/2010. Signed by Magistrate Judge Patty Shwartz on 03/15/2010. (nr, ) (Entered: 03/19/2010)
- 04/09/2010 401 MOTION to Transfer Case to The Western District of Arkansas by NET2PHONE, INC.. (Attachments: # 1 Certificate of Service, # 2 Brief, # 3 Text of Proposed Order)(LASALA, JOSEPH) (Entered: 04/09/2010)
- 04/09/2010 -- Set Deadlines as to 401 MOTION to Transfer Case to The Western District of Arkansas. Motion set for 5/3/2010 10:00 AM before Judge Katharine S. Hayden. The motion will be decided on the papers. No appearances required unless notified by the court. (nr, ) (Entered: 04/12/2010)
- 04/12/2010 402 TEXT ORDER: Scheduling a phone conference for 4/13/2010 5:00 PM. Counsel are directed to coordinate the call and dial into chambers at the assigned time, entered by Judge Katharine S. Hayden on 4/12/10. (rg, ) (Entered: 04/12/2010)
- 04/13/2010 403 Letter from Thomas R. Curtin. (CURTIN, THOMAS) (Entered: 04/13/2010)
- 04/13/2010 -- Minute Entry for proceedings held before Judge Katharine S. Hayden: Status phone conference held on 4/13/2010. (rg, ) (Entered: 04/13/2010)
- 04/13/2010 -- Minute Entry for proceedings held before Magistrate Judge Patty Shwartz: Telephone Conference held on 4/13/2010. (aa, ) (Entered: 04/22/2010)
- 04/14/2010 404 ORDER on informal application setting a briefing schedule on motion to transfer and scheduling oral argument for 5/26/2010 at 10:30a.m.. Signed by Magistrate Judge Patty Shwartz on 04/13/2010. (nr, ) (Entered: 04/14/2010)
- 04/16/2010 405 Letter from Thomas R. Curtin. (CURTIN, THOMAS) (Entered: 04/16/2010)
- 04/23/2010 406 TEXT ORDER: Denying letter request #405 by Thomas Curtin for an adjournment of the 5/26/10 oral argument scheduled in this matter, entered by Judge Katharine S. Hayden on 4/23/10. (rg, ) (Entered: 04/23/2010)
- 04/26/2010 407 BRIEF in Opposition re 401 MOTION to Transfer Case to The Western District of Arkansas filed by EBAY, INC., SKYPE TECHNOLOGIES SA, SKYPE, INC.. (Attachments: # 1 Declaration of Donald Albert, # 2 Declaration of Benjamin Wang, # 3 Exhibit 1 to Wang Decl., # 4 Exhibit 2 to Wang Decl., # 5 Exhibit 3 to Wang Decl., # 6 Exhibit 4 to Wang Decl., # 7 Exhibit 5A to Wang Decl., # 8 Exhibit 5B to Wang Decl., # 9 Exhibit 5C to Wang Decl., # 10 Exhibit 5D to Wang Decl., # 11 Exhibit 5E to Wang Decl., # 12 Exhibit 6 to Wang Decl., # 13 Exhibit 7 to Wang Decl., # 14 Exhibit 8 to Wang Decl., # 15 Exhibit 9 to Wang Decl., # 16 Exhibit 10 to Wang Decl., # 17 Exhibit 11 to Wang Decl., # 18 Exhibit 12 to Wang Decl., # 19 Exhibit 13 to Wang Decl., # 20 Exhibit 14 to Wang Decl., # 21 Exhibit 15 to Wang Decl., # 22 Exhibit 16 to Wang Decl., # 23 Exhibit 17 to Wang Decl., # 24 Exhibit 18 to Wang Decl., # 25 Exhibit 19 to Wang Decl., # 26 Exhibit 20 to Wang Decl., # 27 Exhibit 21 to Wang Decl., # 28 Exhibit 22 to Wang Decl., # 29 Exhibit 23 to Wang Decl., # 30 Exhibit 24 to Wang Decl., # 31 Exhibit 25 to Wang Decl., # 32 Exhibit 26 to Wang Decl., # 33 Exhibit 27 to Wang Decl., # 34 Exhibit 28 to Wang Decl., # 35 Exhibit 29 to Wang Decl., # 36 Exhibit 30 to Wang Decl., # 37 Certificate of Service)(CURTIN, THOMAS) (Entered: 04/26/2010)

Copyright © 2010 LexisNexis CourtLink, Inc. All rights reserved.  
 \*\*\* THIS DATA IS FOR INFORMATIONAL PURPOSES ONLY \*\*\*

Command Searching > Utility, Design and Plant Patents ⓘ

Search ⓘ

Select Search Type and Enter Search Terms

Terms & Connectors	patno=6108704
Natural Language	
Easy Search™	
Semantic Search	
What's this?	

Suggest terms for my search

Check spelling

Restrict by Document Segment

Select a document segment, enter search terms for the segment, then click Add.

Select a Segment  Add ↑

Note: Segment availability differs between sources. Segments may not be applied consistently across sources.

Restrict by Date

No Date Restrictions  From  To  Date formats...

Search Connectors

- [and](#) and [w/p](#) in same paragraph
- [or](#) or [w/seg](#) in same segment
- [w/N](#) within N words [w/s](#) in same sentence
- [pre/N](#) precedes by N words [and not](#) and not
- > [More Connectors & Commands...](#)

How Do I...?

- > [Combine sources?](#)
- > [Restrict by date?](#)
- > [Restrict by document segment?](#)
- > [Use wildcards as placeholders for one or more characters in a search term?](#)

[View Tutorials](#)

Source: [Command Searching > Utility, Design and Plant Patents](#) Terms: [patno=6108704](#) ([Edit Search](#) | [Suggest Terms for My Search](#))

533115 (08) 6108704 August 22, 2000 ,

## UNITED STATES PATENT AND TRADEMARK OFFICE GRANTED PATENT

**6108704**

[Access PDF of Official Patent \\*](#)  
[Order Patent File History / Wrapper from REEDFAX®](#)  
[Link to Claims Section](#)

August 22, 2000 ,

Point-to-point , , internet , , protocol

**REEXAM-LITIGATE:**

Reexamination requested February 17, 2009 by Edwin H. Taylor, Blakely Sokoloff Taylor & Zafman, LLP, Sunnyvale, CA, Reexamination No. 90/010,416 (O.G. April 14, 2009) Ex. Gp.: 3992 February 17, 2009

**APPL-NO:** 533115 (08)**FILED-DATE:** September 25, 1995**GRANTED-DATE:** August 22, 2000 ,**ASSIGNEE-PRE-ISSUE:**

January 8, 1996 - ASSIGNMENT OF ASSIGNORS INTEREST (SEE DOCUMENT FOR DETAILS)., INTERNET TELEPHONE COMPANY SUITE 305 1 SOUTH OCEAN BOULEVARD BOCA RATON, FLORIDA, 33432, Reel and Frame Number: 008295/0167

May 30, 1996 - ASSIGNMENT OF ASSIGNORS INTEREST (SEE DOCUMENT FOR DETAILS)., INTERNET TELEPHONE COMPANY 1 SOUTH OCEAN BOULEVARD, SUITE 305 BOCA RATON, FLORIDA, 33432, Reel and Frame Number: 007981/0020

May 30, 1996 - ASSIGNMENT OF ASSIGNORS INTEREST (SEE DOCUMENT FOR DETAILS)., NETSPEAK CORPORATION STE. 104 902 CLINT MOORE ROAD BOCA RATON, FLORIDA, 33437, Reel and Frame Number: 007981/0053

February 22, 1999 - ASSIGNMENT OF ASSIGNORS INTEREST (SEE DOCUMENT FOR DETAILS)., NETSPEAK CORPORATION, 902 CLINT MOORE ROAD, SUITE 104, BOCA RATON, FLORIDA, UNITED STATES OF AMERICA (US), 33487, Reel and Frame Number: 009792/0568

June 7, 1999 - ASSIGNMENT OF ASSIGNORS INTEREST (SEE DOCUMENT FOR DETAILS)., NETSPEAK CORPORATION 902 CLINT MOORE ROAD, SUITE 104 BOCA RATON, FLORIDA, 33487, Reel and Frame Number: 010012/0953

**ASSIGNEE-AT-ISSUE:**

NetSpeak Corporation, Boca Raton, FLORIDA, United States of America (US)

**ASSIGNEE-AFTER-ISSUE:**

September 12, 2005 - ASSIGNMENT OF ASSIGNORS INTEREST (SEE DOCUMENT FOR DETAILS)., VOIP

TECHNOLOGY HOLDINGS, LLC 520 BROAD STREET, 8TH FLOOR NEWARK NEW JERSEY 07102, ATTN: NET2PHONE LEGAL DEPARTMENT, 520 BROAD STREET, 8TH FLOOR, NEWARK, NEW JERSEY, UNITED STATES OF AMERICA (US), 07102, Reel and Frame Number: 016522/0205

October 28, 2005 - ASSIGNMENT OF ASSIGNORS INTEREST (SEE DOCUMENT FOR DETAILS)., NET2PHONE, INC. 520 BROAD STREET, 8TH FLOOR NEWARK NEW JERSEY 07102, 520 BROAD STREET, 8TH FLOOR, NEWARK, NEW JERSEY, UNITED STATES OF AMERICA (US), 07102, Reel and Frame Number: 016945/0858

October 28, 2005 - ASSIGNMENT OF ASSIGNORS INTEREST (SEE DOCUMENT FOR DETAILS)., NET2PHONE, INC. 520 BROAD STREET, 8TH FLOOR NEWARK NEW JERSEY 07102, 520 BROAD STREET, 8TH FLOOR, NEWARK, NEW JERSEY, UNITED STATES OF AMERICA (US), 07102, Reel and Frame Number: 016945/0890

December 9, 2005 - ASSIGNMENT OF ASSIGNORS INTEREST (SEE DOCUMENT FOR DETAILS)., NET2PHONE, INC. 520 BROAD STREET, 8TH FLOOR NEWARK NEW JERSEY 07102, 520 BROAD STREET, 8TH FLOOR, NEWARK, NEW JERSEY, UNITED STATES OF AMERICA (US), 07102, Reel and Frame Number: 017105/0240

**CORE TERMS:** processing, internet, user, point-to-point, protocol, e-mail, server, icon, input, callee, database, message, display, processor, session, computer, send, memory, screen, stored, alternatively, transmitting, secondary, mouse, host, mail, conjunction, exemplary, telephone, software

Source: [Command Searching](#) > [Utility, Design and Plant Patents](#) 

Terms: [patno=6108704](#) ([Edit Search](#) | [Suggest Terms for My Search](#))

View: [Custom](#)

Segments: [Appl-no](#), [Assignee](#), [Assignee-iiid](#), [Cert-correction](#), [Lit-reex](#), [Reexam-cert](#), [Reexam-litigate](#), [Reissue](#), [Reissue-comment](#)

Date/Time: [Monday, May 3, 2010 - 12:37 PM EDT](#)

[My Lexis™](#) | [Search](#) | [Research Tasks](#) | [Get a Document](#) | [Shepard's®](#) | [Alerts](#) | [Total Litigator](#) | [Transactional Advisor](#) | [Counsel Selector](#)

[History](#) | [Delivery Manager](#) | [Switch Client](#) | [Preferences](#) | [Sign Out](#) | [Help](#)



LexisNexis®

[About LexisNexis](#) | [Terms & Conditions](#) | [Contact Us](#)

Copyright © 2010 LexisNexis, a division of Reed Elsevier Inc. All rights reserved.

Command Searching > Patent Cases from Federal Courts and Administrative Materials ⓘ

Search ⓘ

Select Search Type and Enter Search Terms

Terms & Connectors	6108704 or 6,108,704
Natural Language	
Easy Search™	

Suggest terms for my search

Check spelling

Restrict by Document Segment

Select a document segment, enter search terms for the segment, then click Add.

Select a Segment  Add | ↑

Note: Segment availability differs between sources. Segments may not be applied consistently across sources.

Restrict by Date

No Date Restrictions  From  To  [Date formats...](#)

Search Connectors

- and and w/p in same paragraph
- or or w/seg in same segment
- w/N within N words w/s in same sentence
- pre/N precedes by N words and not and not

> [More Connectors & Commands...](#)

How Do I...?

- > [Combine sources?](#)
- > [Restrict by date?](#)
- > [Restrict by document segment?](#)
- > [Use wildcards as placeholders for one or more characters in a search term?](#)

[View Tutorials](#)



Source: [Command Searching](#) > Patent Cases from Federal Courts and Administrative Materials Terms: 6108704 or 6,108,704 ([Edit Search](#) | [Suggest Terms for My Search](#))

2008 U.S. Dist. LEXIS 50451, \*

NET2PHONE, INC., Plaintiff v. EBAY, INC., et al., Defendants



Civil Action 06-2469 (KSH)

UNITED STATES DISTRICT COURT FOR THE DISTRICT OF NEW JERSEY

2008 U.S. Dist. LEXIS 50451

June 25, 2008, Decided

June 26, 2008, Filed

**NOTICE:** NOT FOR PUBLICATION**SUBSEQUENT HISTORY:** Later proceeding at [Net2Phone, Inc. v. eBay, Inc., 2008 U.S. Dist. LEXIS 87521 \(D.N.J., Oct. 27, 2008\)](#)**CORE TERMS:** patent, privileged, log, disclosure, common interest, handwriting, declaration, legal interests, legal advice, email, attorney-client, untimely, waived, seal, de novo review, deadline, in-house, shareholder, valuation, privileged communication, monetization, anticipation of litigation, tender offer, confidential, negotiation, partial, embody, confidentiality, handwritten, conclusions of law**COUNSEL:** [\*1] For **HOWARD S. JONAS**, Movant: **JOSEPH P. LA SALA** , LEAD ATTORNEY, MCELROY, DEUTSCH, MULVANEY & CARPENTER, LLP, MORRISTOWN, NJ.For **RONALD J. HEDGES**, Mediator, Special Master: **RONALD J. HEDGES** , LEAD ATTORNEY, NIXON PEABODY, NEW YORK, NY.For **NET2PHONE, INC.**,  Plaintiff: **JOSEPH P. LA SALA** , **WILLIAM F. O'CONNOR, JR.** , LEAD ATTORNEYS, MCELROY, DEUTSCH, MULVANEY & CARPENTER, LLP, MORRISTOWN, NJ; **MARIA A. SAVIO** , GOTTlieb RACKMAN & REISMAN, NEW YORK, NY.For **EBAY, INC.** , **SKYPE TECHNOLOGIES SA**, **SKYPE, INC.**, Defendants: **KATHLEEN M. FENNELLY** , **THOMAS R. CURTIN** , LEAD ATTORNEYS, GRAHAM, CURTIN, PA, MORRISTOWN, NJ.For **EBAY, INC.** , **SKYPE TECHNOLOGIES SA**, **SKYPE, INC.**, Counter Claimants: **THOMAS R. CURTIN** , LEAD ATTORNEY, **KATHLEEN M. FENNELLY** , GRAHAM, CURTIN, PA, MORRISTOWN, NJ.For **NET2PHONE, INC.**,  Counter Defendant: **JOSEPH P. LA SALA** , LEAD ATTORNEY, MCELROY, DEUTSCH, MULVANEY & CARPENTER, LLP, MORRISTOWN, NJ.**JUDGES:** Patty Shwartz, United States Magistrate Judge.**OPINION BY:** Patty Shwartz

**OPINION**

SHWARTZ, Magistrate Judge

This matter having come before the Court as a result of objections to the Report of the Special Master dated April 21, 2008 and the motion to seal documents submitted in connection with the objections. For the reasons set forth [\*2] herein, the objections are overruled, the Report is adopted, and the motion to seal is denied.

**I. PROCEDURAL HISTORY**

On June 1, 2006, plaintiff Net2Phone, Inc. ("Net2Phone" or "plaintiff") filed a Complaint against defendants eBay, Inc. ("eBay"), Skype, Inc., Skype Technologies SA ("Skype"), and John Does 1-10 (collectively "defendants") alleging patent infringement <sup>1</sup> and violations of 35 U.S.C. § 271. See Compl. at P 1. Plaintiff filed its First Amended Complaint on June 7, 2006 <sup>2</sup> and followed with its Second Amended Complaint on June 28, 2006 adding additional patents to the lawsuit ("patents-in-suit"). <sup>3</sup> Defendants filed an Answer and Counterclaim denying infringement, validity, and enforceability of the patents-in-suit on September 15, 2006, see Docket Entry No. 17, and plaintiff filed a Response to the Counterclaim on September 20, 2006. See Docket Entry No. 18. Discovery has proceeded in accordance with various scheduling orders.

**FOOTNOTES**

<sup>1</sup> The initial Complaint alleged violation of US. Patent No. 6,108,704. See Compl. at P 14-22.

<sup>2</sup> First Amended Complaint was re-filed on June 9, 2006. See Docket Entry No. 3.

<sup>3</sup> In the Second Amended Complaint added alleged violations of U.S. Patent Nos. 6,701,365, [\*3] 6,009,469, 6,131,121 and 6,226,678. See Second Am. Compl. at PP 23-62.

By way of letters dated November 14, 2007 and November 16, 2007, the parties advised the Court that plaintiff had designated over 1,000 documents as privileged or protected from disclosure under the work product rule and that defendant intended to challenge the majority of the plaintiff's designations. See Order Appointing Special Master at 1. After considering the parties submissions dated November 20, 2007, November 24, 2007, November 30, 2007, and December 3, 2007, the Court concluded that based on the volume of challenges and the likelihood that in camera inspection may be needed, the appointment of a Special Master under Fed. R. Civ. P. 53 to resolve the disputes was warranted. See *id.* at 1-2. The parties concurred in this assessment and, by way of Order dated December 7, 2007, the Court appointed Ronald J. Hedges as Special Master ("Special Master"), Docket Entry No. 146, and, by agreement of the parties, the parties agreed to limit any review of his findings to one level of appeal. Order Appointing Special Master at P 7.

The Special Master conducted five days of hearings, <sup>4</sup> reviewed documents in camera, and [\*4] heard arguments concerning "hundreds of documents" as to which Net2Phone asserted privilege. Findings of Fact and Conclusions of Law of Special Master ("Report") dated April 21, 2008 at 3. In addition to these hearings, the Special Master considered the submissions made pursuant to the Order of September 27, 2007, including defendants' submission dated November 14, 2007 and plaintiff's submission dated November 16, 2007. See *id.* At the January 10, 2008 hearing, the Special Master also gave the plaintiff an opportunity to submit additional evidence to support its privilege claims even though the original submission deadline had passed. See Report at P 5. He advised that no further submissions would be allowed after January 15, 2008. See *id.* The plaintiff and defendants made additional submissions on April 8, 2008 and April 10, 2008 respectively, which the Special Master declined to consider because they were untimely. See *id.*

**FOOTNOTES**

4 These hearings took place on January 10, January 15, February 6, February 7, and March 24, 2008.

On April 21, 2008, the Special Master filed his report wherein he noted that plaintiff eventually produced 4,667 documents that it had previously withheld as privileged. [\*5] Id. at 4. The Special Master also found other documents should be produced. Among other things, the Special Master concluded that, during an approximate one-year period, plaintiff and IDT "did not have any identity (or even similarity) of legal interests." Id. at 14. Accordingly, he found the "common interest" doctrine inapplicable to communications between the plaintiff and IDT and found that documents involving communications between plaintiff and IDT during the time period should be produced. Id. at 16.

The Special Master also concluded that the plaintiff and GE did not have the identical legal interest required for asserting the attorney-client privilege and their communications about a potential financing arrangement were not protected from disclosure. See id. at 22.

As to the valuation and infringement analyses, the plaintiff conceded that it voluntarily disclosed patent analyses and valuations of the patents-in-suit. Id. at 17. Accordingly, the Special Master concluded that the plaintiff waived the privilege over communications (other than those with trial counsel) concerning the following subjects: "(1) whether Skype infringes the NetSpeak patents; (2) whether the NetSpeak patents [\*6] are easy to design around; (3) whether the NetSpeak patents are valid; (4) whether Vonage infringes the NetSpeak patents; (5) whether the PacketCable Specs require use of the NetSpeak patents; and (6) the value of the NetSpeak patents." Id. at 20. The Special Master observed that while the parties may disagree as to particular documents that fall within these subjects, such disagreement is "not yet ripe for judicial review." Id. at 21.

As to the disputes regarding privilege log entries 2623, 2629, 2632, 2633, 2634, 2645, 9062, 1861, 1864, 1870, 3814, 1870, 3814, 1142, 1332, 1333, 1337, 1840, 2783, 4562, 8832-33, 9061, 9073 and 4382, the Special Master concluded that the plaintiff failed to sustain its burden to show that the communications are entitled to protection under the attorney-client privilege or the work-product rule, or that any existing privilege has not been waived. 5 Id. at 5-12.

## FOOTNOTES

s The plaintiff did not appeal the Special Master's rulings regarding log entries 4638-39, 4675, 3893 and 1766.

On May 6, 2008, the plaintiff filed its Rule 53(f) Objections and Motion to Modify Findings of Fact and Conclusions of Law of the Special Master. See Docket Entry No. 224. Defendant filed [\*7] a Response in Opposition to Net2Phone's Objections to the Report of the Special Master on May 21, 2008, see Docket Entry Nos. 232, 233, and plaintiff filed a reply on June 5, 2008. See Docket Entry Nos. 238, 239.

The plaintiff also filed a motion to seal certain documents submitted in connection with its objections. Plaintiff argues that good cause exists to seal the documents because they: (1) disclose a confidential arrangement between IDT and a third party to engage in joint patent enforcement, (2) disclose the name of a competitor against whom IDT was contemplating litigation, (3) contain confidential opinion of counsel on issues of patent infringement, (4) embody certain information that is designated for attorney's eyes only, and (5) contain the confidential agreement between Net2Phone and IDT. The plaintiff asserts that the fact that the Special Master's findings have been posted on the docket does not preclude the plaintiff from seeking to seal the information. In opposition, defendants argue that the plaintiff's motion to seal should be denied because: (1) the plaintiff's request is untimely, (2) none of the information it seeks to seal contains confidential information, and [\*8] (3) the plaintiff has previously disclosed the information it now seeks to be sealed.

## II. DISCUSSION

### A. STANDARD OF REVIEW

The plaintiff argues that: (1) the Court must conduct a de novo review of the Special Master's findings of fact and conclusions of law, and (2) that the Court may review new evidence.

In response, the defendants argue that: (1) the Court should apply the "abuse of discretion" standard when reviewing the Special Master's procedural rulings regarding the discovery process, (2) the Court should show deference to the Special Master's findings on these matters, and (3) even if a de novo standard of review is appropriate, that standard does not permit plaintiff to present new arguments and evidence because allowing it to do so would undermine the purpose of the proceedings before the Special Master and would run counter to the interest of "fair and timely resolution of the issues."

In reply, plaintiff argues that Skype misstates the standard of review because: (1) Fed. R. Civ. P. 53 states that a Special Master's findings of fact and conclusions of law are to be reviewed de novo, and (2) pursuant to Rule 53, the Court may consider new arguments, documents, and evidence as **[\*9]** part of its de novo review. <sup>6</sup>

## FOOTNOTES

<sup>6</sup> Plaintiff denies that they are attempting to raise new arguments, but points out that defendants are raising a whole new set of arguments related to preclusion.

Under Federal Rules of Civil Procedure 53(a)(1)(C), the Court may appoint a Special Master to "address pretrial and posttrial matters." Fed. R. Civ. P. 53(a)(1)(C). The Special Master must report his findings to the court that appointed him and serve a copy of his findings on each party. Fed. R. Civ. P. 53(e). The parties may appeal both the substantive and procedural findings of the Special Master. Fed. R. Civ. P. 53(f)(2); see, e.g., Commissariat A L'Energie Atomique v. Samsung Electronics Co., 245 F.R.D. 177, 179 (D.Del. 2007).

Here, the plaintiff appeals the Special Master's findings of fact, conclusions of law, and procedural decisions. The Special Master made rulings concerning the application of the attorney-client privilege. In this circuit, "the applicability of a privilege is a factual question" and "determining the scope of a privilege is a question of law." In re Bevill, Bresler, & Schulman Asset Management, Corp., 805 F.2d 120, 124 (3d Cir. 1986) (citing U.S. v. Liebman, 742 F.2d 807, 809 (3d Cir. 1984)). **[\*10]** Objections to the Special Master's findings of fact and conclusions of law are reviewed de novo. Fed. R. Civ. P. 53(f)(3) and (4); see, e.g., Wachtel v. Guardian Life Ins. Co., Civ. Nos. 01-4183, 03.-1801, 2006 U.S. Dist. LEXIS 28879, 2006 WL 1320031, at \*3 (D.N.J. May 11, 2006); accord In re Intel Corp. Microprocessor Antitrust Litigation, Civ. No. 05-485, 562 F. Supp. 2d 606, 2008 U.S. Dist. LEXIS 39642, 2008 WL 2156751, at \*1 (D.Del May 14, 2008).

In conducting a de novo review of the Special Master's finding of facts and conclusions of law, the Court is mindful that a

[d]e novo review . . . does not necessarily mean a review that includes the submission of new evidence, particularly when evidentiary proceedings previously occurred before the Special Master. When a record on review "is sufficiently developed the district court may, *in its discretion*, merely conduct a de novo review" of the decision, making its own independent determination. Although de novo review refers to the review based on the record below plus any additional evidence received by the reviewing court, it also refers to review of the decision based only on the record below. The plain language of Rule 53 shows that the review of a Special Master's decision requires the court to make a de novo **[\*11]** determination, not conduct a de novo hearing. Rule 53 is similar to 28 U.S.C. § 636(b)(1)(C), when a district court reviews the recommendations of a magistrate judge, the district judge "may accept, reject, or modify" the findings made by the magistrate and "may receive further evidence." Unlike a de novo hearing, "a de novo determination requires the district judge to 'consider the record which has been developed before the magistrate [judge] and make his own determination on the basis of that record, without being bound to adopt the findings and conclusions of the magistrate [judge].'"

Commissariat a l'Energie Atomique v. Samsung Electronics Co., 245 F.R.D. 177, 179 (D. Del. 2007). "The phrase 'de novo determination' . . . means an independent determination of a controversy that accords no deference to any prior resolution of the same controversy." United States v. Raddatz, 447 U.S. 667, 690, 100 S. Ct. 2406, 65 L. Ed. 2d 424 (1980) (Stewart, J., dissenting)(citing United States v. First City Nat'l Bank, 386 U.S. 361, 368, 87 S. Ct. 1088, 18 L. Ed. 2d 151 (1967)). This, however, does not require the reviewing court to hear new arguments. In fact, courts generally "exclud[e] evidence of new arguments on objections . . . [because] [s]ystematic efficiencies [\*12] would be frustrated and the [Special Master's] role reduced to a mere dress rehearsal. . . . In addition, it would be fundamentally unfair to permit a litigant to set its case in motion before the [Special Master] . . . and -- having received an unfavorable recommendation -- shift gears before the [reviewing] judge." Dunkin' Donuts Franchised Restaurants LLC v. Mehta, Civ. No. 07-0423, 2007 U.S. Dist. LEXIS 67112, 2007 WL 2688710, at \*1-2 (W.D.Pa. 2007) (citing Paterson-Leitch Co., Inc. v. Massachusetts Municipal Wholesale Electric Co., 840 F.2d 985, 991 (1st Cir. 1988)).<sup>7</sup> For these reasons, in an appeal of a Special Master's decision, the parties "cannot raise entirely new arguments for the first time on an objection to a Special Master's Report." World Triathlon Corp. v. Dunbar, 539 F. Supp. 2d 1270, 1278 n. 13 (D.Hawaii 2008) (citing Convolve, Inc. v. Compaq Computer Corp., Civ. No. 00-5141, 2004 U.S. Dist. LEXIS 17502, 2004 WL 1944834, at \*1 (S.D.N.Y. Sept. 1, 2004)).

## FOOTNOTES

<sup>7</sup> Generally, on appeal "[t]he matter of what questions may be taken up and resolved for the first time on appeal is one left primarily to the discretion of the [reviewing court], to be exercised on the facts of individual cases." Singleton v. Wulff, 428 U.S. 106, 121, 96 S. Ct. 2868, 49 L. Ed. 2d 826 (1976).

[\*13] Appellate courts generally require exceptional circumstances in order to hear issues not presented in the court below. Harris Corp. v. Ericsson, Inc., 417 F.3d 1241, 1266 (Fed. Cir. 2005)

With respect to considering additional evidence, the reviewing Court has the discretion to consider additional facts or hear evidence itself if it is needed to make a de novo determination. See Raddatz, 447 U.S. at 692.

Challenges to the Special Master's rulings on procedural matters are only reviewed for an abuse of discretion. Fed. R. Civ. P. 53(f)(5); see, e.g., Wachtel, 2006 U.S. Dist. LEXIS 28879, 2006 WL 1320031, at \*3; accord Gunter v. Ridgewood Energy Corp., 223 F.3d 190, 196-97 (3d Cir. 2000). Among other procedural rulings, the Special Master set deadlines for the presentation of submissions and evidence and precluded evidence not timely submitted.

### i. Special Master's refusal to consider untimely submissions

The plaintiff asks the Court to consider evidence that it failed to present by the deadline that the Special Master had set for the presentation of new evidence. In effect, the plaintiff is asking the Court to overrule a procedural ruling of the Special Master. Here, the Special Master permitted the parties to submit [\*14] certifications in support of their respective positions by January 10, 2008. The Special Master extended this deadline to January 15, 2008, Report at 5, and he notified the parties that he would not consider any submissions after this date. Hr'g Tr. 119:22-120:8, Jan. 10, 2008; Hr'g Tr. 52:16-18, 136:10-20, Jan. 15, 2008. Despite this warning, the plaintiff attempted to submit additional materials on April 8, 2008. The Special Master's decision not to consider plaintiff's untimely submissions was not an abuse of his discretion. First, the plaintiff has not provided the Court with any reason why its submissions were so untimely. Second, the plaintiff has not presented any evidence that it sought an extension of the deadline for submissions from the Special Master. Third, the additional materials contain information that was in plaintiff's control before the deadline passed, namely evidence known to its witnesses about documents in existence years before the January 15 deadline. Fourth, the record indicates that the plaintiff missed the Special Master's deadline to submit additional materials by approximately four months, not a few days. It would be nearly impossible for the Special [\*15] Master to conduct the privilege review and meet the Court imposed deadline to file a report if the parties did not comport with the deadlines for submissions. As such, the Special Master's refusal to consider submissions that were presented more than four months past his deadline is not an abuse of discretion. Thus, the Court will not disturb any of his rulings based upon his decision not to consider the late filed materials.

Moreover, the Court declines to consider any factual materials not timely presented to the Special Master. To allow this without any explanation as to why these materials were not timely presented would render the proceedings before the Special Master nothing more than a moot court exercise. The appointment of a Special Master was made to expedite the resolution of privilege disputes. To this end, the Special Master set deadlines for submissions so he could have a complete record on which to render his rulings. Like all evidentiary proceedings, at some point, the record must be closed. Allowing unending augmentation would mean that the decision-maker would never have the complete record upon which to render a final decision and the adverse party would be deprived [\*16] of an opportunity to confront the new evidence. Here, the parties had ample opportunity to present evidence. They were on notice of the deadline and the consequences of noncompliance. Hr'g Tr. 52:16-20, Jan. 15, 2008. There is no reason to allow further augmentation of the record with evidence clearly available to the plaintiff at the time the Special Master set the original January 15, 2008 deadline. "[T]o do so in this situation," where there has been no explanation provided for the failure to comply, "would emasculate the purpose of the Special Master and Rule 53." Commissariat, 245 F.R.D. at 180.

For these reasons, the Court declines to consider evidence not timely presented to the Special Master.

## ii. Consideration of New Arguments

As to the assertion that the plaintiff has presented new arguments, the Court declines to parse the submissions that were presented to the Special Master and those that are presented to this Court to determine whether new cases are now being presented because all of the arguments raised to the Special Master and to this Court (with the exception of the need to find unfairness before requiring disclosure of documents embodying topics for which there has [\*17] been a waiver) embrace the same legal theories concerning the applicability of the privilege, the common interest doctrine, and waiver. To the extent additional cases are presented, the Court finds that there is no prejudice to any party if the Court considers these cases because each side has had an opportunity to address them. To the extent that the "unfairness" component of the waiver analysis was not argued, consideration of this issue is required but it does not lead to conclusions different from those the Special Master reached. See Convolve, 2004 U.S. Dist., LEXIS 17502, 2004 WL 1944834, at \* 1.

The Court turns to its de novo review of the Special Master's findings of fact and conclusions of law.

## B. Attorney Client Privilege

As a preliminary matter, the Court notes that because jurisdiction is based upon the presence of a federal question, the federal common law of privilege governs this matter. See Fed. R. Evid. 501; Harding v. Dana Transport, Inc., 914 F. Supp 1084, 1090 (D.N.J. 1996)(citing Wm. T. Thompson Co. v. General Nutrition Corp., Inc., 671 F.2d 100, 103 (3d Cir. 1982)).

The purpose of the attorney-client privilege is to encourage "full and frank communication between attorney and their clients." Upjohn Co. v. United States, 449 U.S. 383, 389, 101 S. Ct. 677, 66 L. Ed. 2d 584 (1981); [\*18] Westinghouse Electric Corp. v. Republic of the Philippines, 951 F.2d 1414, 1423 (3d Cir. 1991). Because the attorney-client privilege obstructs the truth-finding process, however, it is construed narrowly and "protects only those disclosures -- necessary to obtain informed legal advice -- which might not have been made absent the privilege." Westinghouse, 951 F.2d at 1423-24 (quoting Fisher v. United States, 425 U.S. 391, 403, 96 S. Ct. 1569, 48 L. Ed. 2d 39 (1976)(emphasis in original)); Harding, 914 F. Supp at 1091 (stating "because the privilege obstructs the search for the truth and because its benefits are, at best, indirect and speculative, it must be strictly confined within the narrowest possible limits consistent with logic of its principle")(citations and internal quotations omitted).

The Court of Appeals for the Third Circuit states the traditional elements of the attorney client privilege as follows:

- (1) the asserted holder of the privilege is or sought to become a client;
- (2) the person to whom the communication was made

(a) is a member of the bar of a court, or his or her subordinate, and

(b) in connection with this communication is acting as a lawyer;

(3) the communication relates to a fact of which the attorney [\*19] was informed

(a) by his client

(b) without the presence of strangers

(c) for the purpose of securing primarily either

(i) an opinion of law or

(ii) legal services or

(iii) assistance in some legal proceeding, and

(d) not for the purpose of committing a crime or tort; and

(4) the privilege has been

(a) claimed and

(b) not waived by the client.

Montgomery County v. MicroVote Corp., 175 F.3d 296, 301 (3d Cir. 1999); Rhone-Poulenc Rorer Inc. v. Home Indem. Co., 32 F.3d 851, 862 (3d Cir. 1994). A party asserting the privilege must show "(1) that it submitted confidential information to a lawyer, . . . (2) that it did so with the reasonable belief that the lawyer was acting as the parties' attorney," Montgomery Acad. v. Kohn, 50 F. Supp. 2d 344, 350 (D.N.J. 1999), and (3) the purpose of the communications was to secure legal, as opposed to business, advice. In re Ford Motor Co., 110 F.3d 954, 965 (3d Cir. 1997). It is, therefore, "vital to a claim of privilege that the communications between client and attorney were made in confidence and have been maintained in confidence." In re Howard Indus., Inc., 67 B.R. 291, 293 (Bankr. D.N.J. 1986) (quoting In re Horowitz, 482 F.2d 72, 81-82 (2d Cir. 1973)); [\*20] see Republic of Philippines v. Westinghouse Electric Corp., 132 F.R.D. 384, 388 (D.N.J. 1990) (stating "a litigant who wishes to assert confidentiality must maintain genuine confidentiality")(citations omitted and emphasis in original). A party may waive the attorney-client privilege through various actions including purposeful disclosure, partial disclosure, and careless disclosure. Edna Epstein, The Attorney-Client Privilege and the Work-Product Doctrine 292-309 (American Bar Association 2001). Under the doctrine of waiver, when "[c]onduct touches a certain point of disclosure, fairness requires that the privilege shall cease whether he intended that result or not." 8 Wigmore, Evidence § 2327 at 636 (1961). Accordingly, a client generally waives the privilege if he or she voluntarily discloses the privileged communication to a third party, Westinghouse, 951 F.2d at 1424; In re Diet Drugs Prods. Liab. Lit., MDL No. 1203, 2001 U.S. Dist. LEXIS 5494, at \*13 (E.D. Pa. April 19, 2001), or fails to take reasonable measures to ensure the confidentiality of communications with counsel. See Kaufman v. SunGard Invest. Sys., Civ. No. 05-1236, 2006 U.S. Dist. LEXIS 28149, 2006 WL 1307882, at \*3 (D.N.J. May 9, 2006); Smithkline Beecham Corp. v. Apotex Corp., 232 F.R.D. 467, 479 (E.D. Pa. 2005)(stating [\*21] that mass dissemination of purportedly confidential communications can destroy an assertion of the privilege).<sup>8</sup>

## FOOTNOTES

<sup>8</sup> Similarly, the work-product privilege precludes disclosure of "materials prepared by an attorney, or an attorney's agent, in anticipation of or for litigation," as well as "[a]n attorney's mental impressions, conclusions, opinions or legal theories." In re Diet Drugs, 2001 U.S. Dist. LEXIS 5494, at \*11 (citing In

re Ford Motor Co. v. Kelly, 110 F.3d 954, 967 (3d Cir. 1997); see also U.S. v. Ernstoff, 183 F.R.D. 148, 153 (D.N.J. 1998); Fed. R. Civ. P. 26(b)(3)). The work product privilege may be waived and "[t]he predicate of the waiver inquiry in the work-product context . . . [is] whether the material was disclosed to an adversary." Maldonado v. New Jersey ex rel. Administrative Office of Courts-Probation Division, 225 F.R.D. 120, 131-32 (D.N.J. 2004). "The essential question with respect to waiver of the work-product privilege by disclosure is whether the material has been kept away from adversaries." Id. (citing Nicholas v. Wyndham Int'l, Inc., Civ. No. 01-147, 2003 WL 23198845, at \*3-4, 2003 U.S. Dist. LEXIS 24086, at \*9 (D.V.I. May 19, 2003)). "The party seeking to [\*22] obtain protected work product bears the burden of proving that the protection has been waived." Hatco Corp. v. W.R. Grace & Co.-Conn., Civ. No. 89-1031, 1991 U.S. Dist. LEXIS 6479, 1991 WL 83126, at \*7 (D.N.J. May 10, 1991). A showing of disclosure to a third party does not result in a waiver of the work product protection if the parties have common interests. Id.

### C. Common Interest Privilege

Here, defendants assert that plaintiff did not share the attorney-client privilege with either IDT or GE and therefore their communications with the plaintiff are not protected from disclosure. Plaintiff argues that, at the time of the communications, it had a common interest with these third parties and their communications are privileged. The "common interest privilege is an extension of the attorney-client privilege and work product doctrine," Block Drug Company, Inc. v. Sedona Laboratories, Inc., Civ. No. 06-350, 2007 U.S. Dist. LEXIS 29028, at \*3 (D. Del. Apr. 19, 2007), and thus is "an exception to the general rule that the [ ] privilege is waived upon disclosure of privileged information to a third party." Katz v. AT&T Corp., 191 F.R.D. 433, 436 (E.D. Pa., 2000) (citing In re The Regents of the University of California, 101 F.3d 1386, 1390 (Fed. Cir. 1996)).

Under [\*23] the common interest doctrine, "although an attorney actually represents only one party, there is no waiver of the attorney-client privilege by disclosure of privileged communications to third parties with a 'community of interest.'" Pittston Co. v. Allianz Ins. Co., 143 F.R.D. 66, 69 (D.N.J. 1992). Parties have a "community of interest" where they "have an identical legal interest with respect to the subject matter of a communication between an attorney and client concerning legal advice. . . . The key consideration is that the nature of the interest be identical, not similar, and be legal, not solely commercial." Id. (citing Duplan Corp. v. Deering Milliken Inc., 397 F. Supp. 1146, 1172 (S.D.S.C. 1974); In re The Regents of Univ. of Cal., 101 F.3d at 1390; In re Diet Drugs, 2001 U.S. Dist. LEXIS 5494, at \*14 (stating that the doctrine preserves a privilege where persons or companies "share a common legal interest in a legal issue or exchange privileged communications with one another"). For the doctrine to apply, the parties must have "an identical legal interest with respect to the subject matter of the communication . . . ." Id.; [\*24] Grider v. Keystone Health Plan Central, Inc., Civ. No. 05-MC-40, 2005 U.S. Dist. LEXIS 44069, at \*21 (M.D. Pa. July 28, 2005). Thus, under "the common interest doctrine . . . 'parties with shared interest in actual or potential litigation against a common adversary may share privileged information without waiving their right to assert the privilege.'" <sup>10</sup> Katz, 191 F.R.D. at 437 (quoting Thompson v. Glenmede Trust Co., Civ. No. 92-5233, 1995 U.S. Dist. LEXIS 18780, at \*15 (E.D. Pa. Dec. 18, 1995)); see also Hewlett-Packard Co. v. Bausch & Lomb, Inc., 115 F.R.D. 308, 309-10 (N.D. Cal. 1987) (applying the doctrine where the communication is in anticipation of a joint litigation). The doctrine, however, does not apply where the third party's interest "'does not appear to be that of a potential co-defendant in a possible . . . action' . . . but rather [is] that of an 'adverse [party], negotiating at arm's length a business transaction between themselves.'" Nidec Corp. v. Victor Comp. Of Japan, Civ. No. 05-0686, 2007 U.S. Dist. LEXIS 48841, at \*13-14 (N.D. Cal. July 3, 2007) (quoting SCM Corp. v. Xerox Corp., 70 F.R.D. 508, 512-13 (D. Conn. 1976)). In short, to assert the common interest doctrine, plaintiff must show: (1) the material is privileged, [\*25] Grider, 2005 U.S. Dist. LEXIS 44069, at \*20 (stating that "[t]he common interest privilege 'does not create an independent privilege, but depends upon a proper showing of the other elements of' . . . [a] recognized privilege before it will apply"), (2) "the parties had an identical legal and not solely commercial interest," In re The Regents of Univ. of Cal., 101 F.3d at 1390; Katz, 191 F.R.D. at 438, and (3) the communication was designed to further the shared legal interest. Nidec Corp., 2007 U.S. Dist. LEXIS 48841, at \*10-11. Here, the Court will assume, without deciding, the first prong is met and the materials plaintiff seeks to withhold would be privileged if disclosed between an attorney and a client. As such, the Court turns to consider whether or not the remaining two prongs are met.

### FOOTNOTES

Page 1740 of 1928

[http://www.lexis.com/research/retrieve?\\_m=aff620f1a628e50b2d8c83677b0](http://www.lexis.com/research/retrieve?_m=aff620f1a628e50b2d8c83677b0)



<sup>9</sup> Remington Arms Co. v. Liberty Mutual Insurance Co., 142 F.R.D. 408, 418 (D. Del. 1992) (declining to apply the common interest doctrine because "the rationale which supports the common interest exception to the attorney-client privilege simply doesn't apply if the attorney never represented the party seeking the allegedly privileged materials."); see also Pittston Co., 143 F.R.D. at 70.

<sup>10</sup> Of course, [\*26] "[e]ven if there were a common legal interest, the common interest exception requires that the communication at issue be 'designed to further that [legal] effort.'" Nidec Corp. v. Victor Comp. Of Japan, Civ. No. 05-0686, 2007 U.S. Dist. LEXIS 48841, at \*15 (N.D. Cal. July 3, 2007) (quoting United States v. Bergonzi, 216 F.R.D. 487, 495 (N.D. Cal. 2003) (alteration and emphasis in original)).

#### I. Communications between Net2Phone and IDT

Plaintiff argues that the common interest privilege protects communications between plaintiff and IDT because: (1) plaintiff and IDT were closely affiliated companies with identical legal interests in preserving plaintiff's intellectual property, (2) the limited adversity between plaintiff and IDT as to a tender offer did not waive privilege on all issues, and (3) the common interest privilege between plaintiff and IDT arose separately from the IP Agreement.

The defendants argue that the common interest privilege does not apply to IDT and plaintiff between April 4, 2005 and March 13, 2006 because: (1) plaintiff and IDT were separate, publicly-traded corporations, (2) they did not share a common interest because their communications were not between a parent [\*27] corporation and its wholly-owned subsidiary, (3) IDT did not then have any interest in the patents-in-suit, (4) the lack of adversity between the two corporations on certain topics does not necessarily imply they shared identical legal interests in those areas, (5) there is no evidence that either party to the communications considered the relationship between them to be that of attorney-client, (6) after the termination of the Intellectual Property Legal Services Agreement and before the acquisition, there was no existing legal relationship between the plaintiff and IDT that would permit application of the common interest privilege as reflected by plaintiff's use of its own counsel to enforce its patent portfolio, instead of IDT's attorneys, (7) IDT and plaintiff never entered into an agreement or placed any confidentiality restrictions on each other, (8) the information was disclosed for commercial purposes, and not to form a joint defense, and (9) the plaintiff has failed to show that joint legal activity between plaintiff and IDT was likely.

Here, a de novo review shows that the Special Master's conclusion that the communications between plaintiff and IDT between the dates April [\*28] 4, 2005 and March 12, 2006 are not subject to the common interest privilege doctrine is correct. First, there was no common legal interest between plaintiff and IDT during the dates of April 4, 2005 and March 12, 2006. See Stott-Bumsted Dec. Ex. 5 ("S.E.C. Schedule 14D-9") at 28-35. <sup>11</sup> April 4, 2005 is the date plaintiff's termination of its contractual relationship with IDT became effective. *Id.* at 28. March 13, 2006 is the date that IDT's acquisition of Net2Phone became effective. Thus, from April 4, 2005 to March 13, 2006, the parties were and functioned as separate, publically traded companies. See *id.* at 28-35. Indeed, after April 4, 2005, the independent committee of plaintiff affirmed that it was "not aware of any other arrangement that gave IDT any interest in the Netspeak patents, other than as an indirect interest as a shareholder of Net2Phone." Accordingly, we understand that no agreement exists between IDT and Net2Phone that gives IDT an interest in the Netspeak patents." *Id.* at 29. Second, from April 4, 2005 to March 13, 2006, IDT and Net2Phone had adverse interests because IDT and Net2Phone were negotiating the price IDT would pay for Net2Phone's shares. See *id.* Indeed, [\*29] the plaintiff concedes that IDT was adverse to Net2Phone but argues that it was only on the issue of the price IDT would pay for Net2Phone shares. The fact that the parties were adverse in the price per share for Net2Phone illustrates that the parties were indeed separate entities negotiating at arms length in a commercial transaction. Corning, Inc. v. SRU Biosystems, LLC, 223 F.R.D. 189, 190 (D.Del. 2004); SCM Corp., 70 F.R.D. at 525, Nidec Corp., 2007 U.S. Dist. LEXIS 48841, at \*13-14 (citing cases); see also Katz, 191 F.R.D. at 438 (no common interest between parties before reaching licensing agreement because such negotiations do show an identity of legal interests). Third, the relationship between plaintiff and IDT was that of a corporation and its controlling shareholder. Simply because in-house counsel enforced the corporation's patents, which would benefit its shareholders, does not mean that they shared a legal interest. Put differently, a legal interest cannot arise simply because a

company acts in a way that advances the economic interests of its majority shareholder. A logical extension of plaintiff's argument would expand the application of the common interest doctrine [\*30] to cover all business transactions where a company acted in the interest of its majority shareholder. While shareholders and the corporation may share an interest in commercial success, this shared economic interest is not a legal interest. Moreover, IDT's direct contractual interest in the plaintiff's patents ended when the intellectual property agreement ended. In short, during this period, these legally separate entities had no mutual obligation and were engaging in negotiations to change their commercial relationship and they then shared no common legal interest. Their separate interests on legal issues is demonstrated by the representations to the SEC that plaintiff retained counsel for services that IDT had formerly provided. S.E.C. Schedule 14D at 13, 28-29. Finally, there is no indication that the communications associated with the tender offer were disclosed to further a common legal strategy or joint interest in pending or anticipated litigation. Rather, the information was shared to further a commercial transaction between legally separate entities. Nidec Corp., 2007 U.S. Dist. LEXIS 48841, at \*15-16.

## FOOTNOTES

<sup>11</sup> Exhibit 5 is a Schedule 14D-9 Solicitation/Recommendation Statement filed [\*31] by IDT with the Securities and Exchange Commission detailing to its shareholders the tender offer for the outstanding Net2Phone ↘ shares.

The cases plaintiff embraces do not change this result. Plaintiff's reliance on In re Teleglobe Communications Corp., 493 F.3d 345 (3d Cir. 2007), for the proposition that parent and subsidiary corporations are joint clients and thus afforded the common interest privilege is unpersuasive because: (1) the Teleglobe court applied Delaware state law, rather than Federal common law; and (2) the communications in Teleglobe were between parent-subsidiary and not between the corporation and its majority shareholder. For these reasons, Teleglobe does not change the analysis.

In addition, Hewlett-Packard Co., 115 F.R.D. at 310, does not advance the plaintiff's position as the facts in Hewlett-Packard Co. are distinguishable. In finding a common interest privilege between two parties, the court in Hewlett-Packard Co. observed that the defendant and its prospective business partner shared information pursuant to a confidentiality agreement. Moreover, the court observed that each faced litigation from the same plaintiff, and "[i]n such a lawsuit[,] defendant would [\*32] be defending its marketing of the product in the years preceding the sale and GEC would be defending its marketing of exactly the same product in the years following the sale. Thus, at the time defendant and GEC were negotiating it seemed quite likely that defendant and GEC would be sued by plaintiff and that in that litigation defendant and GEC would be identically aligned, fighting to protect interests distinguished only by the time frame in which the marketing took place." *Id.* For these reasons, the court opined that the defendant and GEC would likely pursue a joint defense in defending the patent claims. *Id.* Here, there is nothing to show that plaintiff and IDT shared information under a confidentiality agreement nor is there evidence that at the time of the communication IDT and plaintiff faced the prospect of imminent litigation or a common adversary.

For these reasons, and on a de novo review, the Court finds that IDT and Net2Phone ↘ did not have a common legal interest during the period April 4, 2005 through March 13, 2006 and the Special Master's conclusions are adopted.

## II. Communications between Net2Phone ↘ and GE

At some point during 2005, IDT and GE contemplated partnering to [\*33] enforce IDT's patent portfolio through litigation or licensing. See Stott-Bumsted Dec. Ex. 17 (Email from James DiGiorgio, senior counsel to IDT, to David Greenblatt and "Ldiaz"). The transaction was to be structured as a loan from GE to IDT in the amount of a hundred million dollars. *Id.* The loan was to be repaid from the proceeds of the licencing/enforcement of the NetSpeak patent portfolio. *Id.* Any licencing/enforcement revenue above a hundred million dollars would be shared by GE and IDT on a pre-defined basis. *Id.*

The plaintiff argues that the communications between IDT and GE about joint enforcement of the NetSpeak patents are subject to the common interest privilege because the contemplated relationship between GE and IDT was not limited to a commercial transaction but rather involved both parties having an identical legal interest in the enforcement of the patents at issue. Finally, plaintiff argues that the fact that GE and

IDT did not consummate their negotiations is irrelevant because the appropriate standard is whether or not the parties contemplated joint legal action, which GE and IDT did. Plaintiff also points out that the parties intended to keep their communications [\*34] confidential, which is a hallmark of the attorney-client privilege.

The defendant argues that the common interest privilege does not apply to the IDT-GE communications because: (1) the parties did not have a common legal interest, (2) the agreement contemplated between the parties did not move past the negotiation stage, (3) the parties did not execute a confidentiality agreement, and (4) the cases the plaintiff relies on are distinguishable.

Here, it is undisputed that IDT and GE had discussed an agreement where GE proposed to partner with IDT to enforce the patents through litigation or licensing. *Id.* This proposed business arrangement was to be configured as a loan, in which GE would lend IDT money which would be re-paid with the proceeds from any fruitful litigation or licensing agreements. *Id.* The interest here was commercial not legal. First, the arrangement between the parties was a proposed financing arrangement between independent entities. At the time of the negotiations, their interest was commercial and their communications during the negotiations were to further that interest and not a legal position. Second, at the time of the negotiations, GE was not a licensee, potential [\*35] licensee, or owner of the patent. Third, although GE maintained the information received and shared with IDT in confidence, *Stott-Bumsted Dec. Ex. 18 at P 5*, the plaintiff has failed to show that there was a strict confidentiality agreement to do so or that their negotiations were conducted to advance a legal rather than a commercial interest.

Moreover, and as discussed above, *Hewlett-Packard Co.*, 115 F.R.D. at 310, does not advance the plaintiff's position. Here, plaintiff and GE did not face the prospect of imminent litigation. There was neither a threat of impending legal action against them nor was there a common adversary. Rather, GE and plaintiff were negotiating a business transaction whereby GE would loan plaintiff money that would be repaid through patent enforcement actions or licensing of patents. Had the agreement come to pass, then communications to further the enforcement activity may have been protectable but the purpose of the communications during the negotiations were to entice a third-party to loan plaintiff money and not to further a then-shared legal interest. For these reasons, the common interest doctrine does not cover the communications between plaintiff and [\*36] GE and the conclusions of the Special Master are adopted.

Having determined that communications between IDT and plaintiff during the period April 4, 2006 and March 13, 2006 and the communications between plaintiff and GE are not privileged, the documents reflecting these communications must be disclosed.

### III. Waiver

The Court next considers whether or not disclosure to these entities and disclosures to plaintiff's shareholders waives the privilege asserted over communications concerning the same topics. Generally, privileged material disclosed to a third party waives the privilege. *Westinghouse Electric Corp.*, 951 F.2d at 1425; *Bulow v. Bulow*, 828 F.2d 94, 103 (2d Cir. 1987). The Third Circuit has identified two distinct forms of "limited" waiver: selective waiver and partial waiver. *Westinghouse*, 951 F.2d at 1423 n.7. Selective waiver "permits the client who has disclosed privileged communications to one party to continue asserting the privilege against other parties" whereas partial waiver "permits a client who has disclosed a portion of privileged communications to continue asserting the privilege as to the remaining portions of the same communications." *Id.* (citations omitted). While [\*37] fairness is not a consideration in selective waiver cases, it is a "central element" of a court's determination where partial waiver is invoked. *Harding*, 914 F.Supp at 1092; see also *Westinghouse*, 951 F.2d at 1426 (stating that "[g]enerally, the 'fairness doctrine' is invoked in partial (as opposed to selective) disclosure cases"). With a partial waiver, "the privilege is waived only as to the communication actually disclosed unless a partial waiver would be unfair to the party's adversary." *Westinghouse*, 951 F.2d at 1426 n.13; *Wachtel*, 2006 U.S. Dist. LEXIS 27591, 2006 WL 1286188, at \*1 n. 2; *In re Intel Corp.*, 2008 WL 2310288, at \*10; *In re Linerboard Antitrust Litigation*, 237 F.R.D. 373, 388 (D.Pa. 2006). The fairness component seeks to "prevent prejudice to a party and distortion of the judicial process that may be caused by the privilege holder's selective disclosures . . . of otherwise privileged information." *In re Intel Corp.*, 2008 WL 2310288, at \*10 (citations omitted). A waiver can occur when a party attempts to use the communication in a litigation or where the party "makes factual assertions, the truth of which can only be assessed by examination of the privileged communications." *Id.* at 11. As the [\*38] Intel court observed concerning disclosure of a report about document production, by

disclosing summaries of a report, it "placed the accuracy and validity of the information contained in these summaries at issue." *Id.* at 12. The Intel court reasoned that to conclude otherwise would enable Intel to assert facts as a sword and shield the adversary from challenging the accuracy of the assertions.

The plaintiff objects to the Special Master's conclusion that it waived privilege on the subjects of whether: (1) Skype infringes the NetSpeak patents, (2) NetSpeak patents are easy to design around, (3) NetSpeak patents are valid, (4) Vonage infringes the NetSpeak patents, (5) PacketCable Specs require the use of the NetSpeak patents, and (6) the value of the NetSpeak patents. The plaintiff argues that: (1) disclosure of a few communications between the parties should not result in subject matter waiver in the aforementioned topics; (2) according to the Court of Appeals for the Third Circuit, privilege is waived only as to those communications actually disclosed unless a partial waiver would be unfair to the party's adversary, and there has been no showing of unfairness nor prejudice here, (3), [**\*39**] the plaintiff is willing to alleviate any fear of future prejudice to the defendants by agreeing not to "affirmatively rely on any of the partial disclosures at issue at any future stage in litigation," *Pl. Reply Br.* at 8, and (4) the subject matter waiver defendants demand would unfairly prejudice the plaintiff in other litigations because the scope of the Special Master's conclusions were not necessarily limited to the patents at issue in the present litigation.

The defendants argue that the Special Master correctly interpreted the scope of the subject matter waiver regarding the analyses and valuations of patents-in-suit. The defendants assert that: (1) they need not show prejudice under Third Circuit law and, in any event, defendants have been prejudiced by the plaintiff's withholding of documents because the plaintiff has selectively disclosed documents to support its argument while withholding others on the same subject that may contradict its position, (2) the Special Master correctly imposed the appropriate limitation on the subject matter waiver when he determined that the waiver covers all documents except communications with trial counsel, and (3) that the plaintiff's complaint [**\*40**] regarding temporal limitations to the waiver should be rejected because it is untimely.

A de novo review of the scope of the waivers that resulted from disclosures of the Monetization Plan, summaries of the CRA Report, and opinions of Douglas Derwin demonstrates that the Special Master's conclusions are correct.

#### 1. Monetization Plan and CRA Report <sup>12</sup>

#### FOOTNOTES

<sup>12</sup> Attached as Exhibit A to the Declaration of Hannah Stott-Bumsted, dated May 5, 2008.

According to the plaintiff, IDT's and plaintiff's attorneys prepared and presented a Monetization Plan to shareholders, which discussed, among other things, the implementation of a licensing and patent sale strategy. The plan was also used during the tender offer negotiation to provide information about the value of the patents. During the tender offer negotiations, plaintiff's counsel also obtained a report from CRA International concerning the value of the patents. The report's conclusion was disclosed to the shareholders because the valuation was material to their decision about tendering their shares but the analysis was not disclosed.

A de novo review shows that the plaintiff waived its assertion of privilege concerning valuation. The plaintiff affirmatively [**\*41**] disclosed valuation information when it advanced its interest. As to the Monetization Plan, it was publicly disclosed in IDT's 14-D9 Securities and Exchange filing in connection with its tender offer. S.E.C. Schedule 14D-9 at 28. Similarly, the conclusions in the CRA Report were disclosed to shareholders and referred to in IDT's 14-D9 Securities and Exchange filing. *Id.* at 31, 44-45. There is no dispute that the topic of valuation was widely disseminated. Thus, at a minimum, the plaintiff engaged in a selective waiver when it disclosed the Monetization Report and the conclusions in the CRA report to its shareholders and others with an interest in the tender offer. Fairness is not a consideration in selective waiver cases, and thus the Special Master was correct in declining to undertake a fairness analysis.

Moreover, there is at least a partial waiver as it relates to the CRA report. Plaintiff disclosed the conclusions but not the analysis or reasoning for the conclusions. If viewed as a partial waiver, the Court must consider whether or not it would be unfair to the defendant to allow the plaintiff to withhold the remainder of the report. The Court finds that it would be unfair to [**\*42**] allow the plaintiff to withhold the analysis portion

of the report.

First, the plaintiff seeks to rely on valuation to make arguments concerning damages. Even if the Monetization Plan or CRA Report are not offered affirmatively in evidence, plaintiff embraced them in the context of a commercial event and defendants should have an opportunity to investigate the bases for valuations contained in these documents and challenge the plaintiff's present valuation position with them. It would be unfair to allow plaintiff's to take one position in one context to advance its commercial purposes and preclude defendants from seeing if it took a different position in litigation. The defendants should be able to impeach plaintiff with its own statements or those it embraced on this topic. See V. Mane Fils S.A. v. Int'l Flavors and Fragrances, 249 F.R.D. 152, 2008 WL 619207, at \*3 (D.N.J. 2008). Second, the plaintiff's representation that they do not intend to use these documents is insufficient. Plaintiff has not abandoned a desire to offer evidence about the value of its patents and thus the subject to which the documents relate is still present in this case and should be documents that [\*43] defendants can examine. For all of these reasons, the Special Master's subject-matter waiver finding regarding valuation is correct.

## 2. Patent Opinions

IDT and plaintiff disclosed patent opinions outside the attorney-client relationship. According to the plaintiff, IDT retained Doug Derwin to evaluate a lawsuit against Vonage for infringement of the NetSpeak patents. In an October 2005 email, Doug Derwin disclosed his analysis to third parties about whether or not certain products infringe on plaintiff's patents, see Stott-Bumsted Dec. Ex. 4 at 1-2 (Email from Ely D. Tandler, Chief Legal Officer for IDT, to Doug Derwin and Abbe L. Dienstag) and provided an opinion that NetSpeak patents are easy to design around. Id. at 2. Derwin's views were then discussed by various third parties at a meeting in October 2005 consisting of legal counsel, consultants and technical personnel for both plaintiff and IDT at a time when plaintiff and IDT had no legal relationship beyond IDT's ownership of some of plaintiff's shares and at a time they had no shared legal interests. S.E.C. Schedule 14D at 31. Patent opinions were also embodied in the Monetization Plan. Specifically, the Monetization Plan included [\*44] information pertaining to whether the NetSpeak patents are valid and whether the PacketCable Specs require use of the NetSpeak patents. S.E.C. Schedule 14D at 29. Plaintiff contends these disclosures were made to "an affiliate" in the context of a tender offer and the disclosure does not waive the privilege over other communications on the same subject and the Special Master's order directing disclosure was wrong because there was no finding of prejudice from nondisclosure of other communications on this subject.

When Mr. Derwin made his disclosures, the plaintiff and IDT did not share a common interest. Moreover, Mr. Derwin was acting only on behalf of IDT when he made his disclosures. Thus, by announcing his patent infringement opinions beyond IDT, the privilege has been waived on these subjects. Similarly, the Monetization Plan, which includes comments about the Net2Speak patents, was widely disseminated. Allowing plaintiff to withhold other communications on this subject would be unfair to the defendants. Defendants should be able to counter plaintiff's attempts to undermine Mr. Derwin's opinion and be confronted with their own views as announced in the Monetization Plan, particularly [\*45] if the plaintiff attempts to distance itself from these opinions in this litigation about patents involving a similar technology.

Based upon these disclosures and the prejudice to the defendants by limiting the disclosure to the actual communication plaintiff conveyed to IDT and plaintiff's shareholders, and upon consideration of the subjects implicated by these disclosures, the Court finds that the Special Master correctly found that the plaintiff waived the privilege to the following topics: (1) whether Skype infringes the NetSpeak patents; (2) whether the NetSpeak patents are easy to design around; (3) whether the NetSpeak patents are valid; (4) whether Vonage infringes the NetSpeak patents; (5) whether the PacketCable Specs require use of the NetSpeak patents; and (6) the value of the NetSpeak patents. The absence of temporal limits to the scope of the waiver is consistent with the fact that certain of the disclosures do not have temporal limits. The Court notes that the Special Master imposed a temporal limitation on communication between IDT and the plaintiff and this reflects he was mindful of the applicability of such limits when appropriate.

For all of these reasons, the Court [\*46] overrules that plaintiff's privilege assertion over responsive documents embodying: (1) communications between plaintiff and IDT during the period April 4, 2005 through March 16, 2006; (2) communications between plaintiff and GE; and (3) communications (except

those with trial counsel) falling within the following categories: (a) whether Skype infringes the NetSpeak patents; (b) whether the NetSpeak patents are easy to design around; (c) whether the NetSpeak patents are valid; (d) whether Vonage infringes the NetSpeak patents; (e) whether the PacketCable Specs require use of the NetSpeak patents; and (f) the value of the NetSpeak patents. The plaintiff shall produce the withheld documents no later than June 30, 2008.

#### D. Specific Documents

The plaintiff also objects to the Special Master's privilege rulings concerning specific documents. The plaintiff bears the burden to prove that any document that does not appear privileged on its face is in fact privileged material. To this end, it must present evidence about the identity of the author of the document and the reason for its creation. For the reasons set forth herein, plaintiff has not met its burden.

i. Entry 2623 (Exhibit D) <sup>13</sup>

#### FOOTNOTES

<sup>13</sup> The [\*47] Exhibits are attached to the Declaration of Hannah Stott-Bumsted, dated May 5, 2008.

The Special Master concluded that the handwriting on log entry 2623 is not subject to privilege. Plaintiff states that the Special Master erred in this ruling because, although the plaintiff could neither identify the author of the writing nor its purpose, the substance of the writing indicates that it contains legal impressions. The plaintiff asserts that the two sentences handwritten at the top of the first page reflects a legal comparison of the subject matter of the underlying document with another patent. The defendants argue that the Special Master reviewed the handwritten notes and did not err when he concluded that the privilege did not apply to the handwriting on entry 2623 because plaintiff failed to sustain its burden of proof and was correct in refusing to consider the Declaration of Joseph John, a senior technical director at during the relevant period, because it was submitted more than two months after the deadline.

The privilege log describes the document as embodying work product <sup>14</sup> and lists the author as Oblon Spivek. The plaintiff concedes, however, that it does not know the identity [\*48] of the author of the handwriting. Pl. Br. at 24-25. Moreover, its effort to prove the identity circumstantially through the Declaration of Joseph John dated March 13, 2008 fails because it was submitted approximately two months after the Special Master's January 15, 2008 deadline. Stott-Bumsted Dec. Ex. 19 ("Joseph John's Dec."). Because it was not timely submitted, the Court will not consider it. Moreover, the record silent as to whether or not the document was prepared in anticipation of litigation and for no other purpose, which is critical to sustaining the assertion of work product. Without the identity of the author and the purpose for which the writings were made, the plaintiff cannot establish that the writings on these documents are privileged or protected by the work product rule.

#### FOOTNOTES

<sup>14</sup> Rule 26 (b)(3) of the Federal Rules of Civil Procedure provides, in relevant part:

(A) Documents and Tangible Things. Ordinarily, a party may not discover documents and tangible things that are prepared in anticipation of litigation or for trial by or for another party or its representative (including the other party's attorney, consultant, surety, indemnitor, insurer, or agent). But, subject to [\*49] Rule 26(b)(4), those materials may be discovered if:

(i) they are otherwise discoverable under Rule 26(b)(1); and

(ii) the party shows that it has substantial need for the materials to prepare its case and cannot, without undue hardship, obtain their substantial equivalent by other means.

(B) Protection Against Disclosure. If the court orders discovery of those materials, it must protect against disclosure of the mental impressions, conclusions, opinions, or legal theories

of a party's attorney or other representative concerning the litigation.

Fed. R. Civ. P. 26(b)(3). Rule 26(b)(3) essentially establishes "two tiers of protection: first, work prepared in anticipation of litigation by an attorney or his agent is discoverable only upon a showing of need and hardship; second, 'core' or 'opinion' work product that encompasses the 'mental impressions, conclusions, opinion, or legal theories of an attorney or other representative of a party concerning the litigation' is 'generally afforded near absolute protection from discovery.'" In re Cendant Corp. Sec. Litig., 343 F.3d 658, 663 (3d Cir. 2003) (quoting United States v. Nobles, 422 U.S. 225, 238-239, 95 S. Ct. 2160, 45 L. Ed. 2d 141 (1975)). As discussed by District Judge Stanley Chessler [\*50] in In re Gabapentin Patent Litigation, 214 F.R.D. 178 (D.N.J. 2003),

Courts generally, and in this Circuit in particular, have applied what amounts to a two part test for ascertaining whether the documents (or things) at issue should be protected under the . . . work product privilege. The first prong of the inquiry is the "reasonable anticipation" test, which requires that the court determine at what point in time litigation could reasonably have been anticipated. Whether a particular document was prepared in "anticipation of litigation" is . . . incapable of precise definition. In general, though, a party must show more than a remote prospect, an inchoate possibility, or a likely chance of litigation. Rather, a party must show that there existed an identifiable specific claim of impending litigation when the materials were prepared. The mere involvement of, . . . or investigation by an attorney does not, in itself, evidence the "anticipation of litigation." Neither will the mere fact that litigation actually occurred establish that the documents prepared before the litigation were created in anticipation thereof.

This Circuit has imposed an additional requirement beyond that embodied [\*51] in the reasonable anticipation test. Thus, the second prong of the test is whether the material [was] produced because of the litigation and for no other purpose. In order to determine whether a document satisfies this standard, the proper inquiry is whether in light of the nature of the document and the factual situation in the particular case, the document can fairly be said to have been prepared or obtained because of the prospect of litigation. Documents created for other purposes that prove useful in subsequent litigation are not . . . work product; similarly, documents that are routinely prepared in the ordinary course of business are outside the scope of work product protection. Even where reasonable anticipation of litigation is established, whether the document comes within the purview of work product privilege still depends primarily on the reason or purpose for the document's production. Finally, the articulable claim likely to lead to litigation must pertain to this particular party, not the world in general.

In re Gabapentin Patent Litigation, 214 F.R.D. at 183-184 (citations and quotations omitted)(emphasis added).

## ii. Entry 2629 (Exhibit E)

The Special Master concluded [\*52] that the handwriting on log entry 2629 is not subject to privilege. Plaintiff states that the Special Master erred in this ruling because, although the plaintiff could neither identify the author of the writing nor the purpose of it, the substance of the writing indicates that it contains legal conclusions about priority date. The defendants argue that the Special Master reviewed the handwriting and did not err when he concluded that the privilege did not apply to the handwritten entries on 2629 because plaintiff failed to sustain its burden of proof and Mr. John's Declaration is untimely and insufficient.

According to the log, plaintiff has asserted that the handwriting is protected by the attorney-client privilege. Although the log states the author is "Joe John," no timely submitted evidence establishes the identity of the author of the handwriting. Without proof of the identity of the author and the purpose for which the writings were made, the plaintiff cannot establish that the handwriting is privileged.

## iii. Entry 2632 (Exhibit F)

The Special Master concluded that the handwriting on log entry 2632 is not subject to privilege. Plaintiff states that the Special Master erred in this [\*53] ruling because, although the plaintiff could neither identify the author of the writing nor its purpose, the substance of the writing indicates that it contains legal conclusions about prior art. The defendants argue that the Special Master reviewed the handwriting and did not err when he concluded that the privilege did not apply to the handwritten entries on 2632 because plaintiff failed to sustain its burden of proof and Mr. John's Declaration is untimely and insufficient.

According to the log, plaintiff asserts that the handwriting on the document is privileged and protected work product. The timely presented record, however, does not reflect that the notes were made in anticipation of litigation nor does it establish the author of the handwriting. Moreover, although the log identifies Mr. Spivek as the author, the plaintiff concedes that it does not know the identity of the author for handwriting on entry 2632. See *id.* Without the identity of the author and the purpose for which the writings were made, the plaintiff cannot establish that the writing on the documents are privileged or protected work product.

#### iv. Entry 2633 (Exhibit G)

The Special Master concluded that the handwriting [\*54] on log entry 2633 is not subject to privilege. Plaintiff states that the Special Master erred in this ruling because, although the plaintiff could not identify the author of the writing nor its purpose, the substance of the writing indicates that it contains legal conclusions about the patent's priority date. The defendants argue that the Special Master reviewed the handwriting and did not err when he concluded that the privilege did not apply to the handwritten entries on 2633 because plaintiff failed to meet its burden of proof and Mr. John's Declaration is untimely and insufficient.

According to the log, plaintiff asserts that the document contains handwriting protected by the attorney-client privilege and work product rule. Although the log identifies Mr. Spivek as the author, plaintiff concedes that it does not know the identity of the author for writings on entry 2633. See *id.*

[\*55] Moreover, the record is silent as to whether the notations were made in anticipation of litigation. Without the identity of the author and the purpose for which the writings were made, the plaintiff cannot establish that the writings on these documents are privileged or protected by the work product rule.

#### v. Entry 2634 (Exhibit H)

The Special Master concluded that the handwriting on log entry 2634 is not subject to privilege. Plaintiff states that the Special Master erred in this ruling because, although the plaintiff could neither identify the author of the writing nor its purpose, the substance of the writing indicates that it contains legal conclusions about prior art. The defendants argue that the Special Master reviewed the handwriting and did not err when he concluded that the privilege did not apply to the handwritten entries on 2634 because plaintiff failed to sustain its burden of proof and Mr. John's Declaration is untimely and insufficient.

According to the log, plaintiff asserts that the handwriting on the document is protected by the attorney-client privilege and work product rule. Although Mr. Spivek is listed on the log as the author, plaintiff concedes that it does not [\*56] know the identity of the author for writings on entry 2634. See *id.* Moreover, the record is silent as to whether the notations were made in anticipation of litigation and for no other purpose. Without the identity of the author and the purpose for which the writings were created, the plaintiff cannot establish that the writings on these documents are privileged or protected by the work product rule.

#### vi. Entry 2645 (Exhibit I)

The Special Master concluded that the handwriting on log entry 2645 is not privileged. Plaintiff states that the Special Master erred in this ruling because, although the plaintiff could neither identify the author of the writing nor its purpose, the substance of the writing indicates that it contains legal conclusions that compare the patent's claim to certain technology. The defendants argue that the Special Master reviewed the handwriting and did not err when he concluded that the privilege did not apply to the handwritten entries on 2645 because the plaintiff failed to carry its burden of proof and Mr. John's Declaration is untimely and insufficient.



According to the log, plaintiff asserts that the document is protected by the attorney-client privilege. The record, [\*57] however, does not establish the identity of the author and the log merely asserts that the author is in-house counsel. Plaintiff concedes that it does not know the identity of the author, see id., and without the identity of the author and the purpose for which the writings were made, the plaintiff cannot establish that the writings on these documents are privileged. Moreover, the writing embodies a series of questions about a product and does not appear privileged on its face. Thus, the plaintiff has failed to meet its burden to sustain the privilege.

vii. Entry 9062 (Exhibit J)

The Special Master concluded that the writings on log entry 9062 are not privileged. Plaintiff states that the Special Master erred in this ruling because, although the plaintiff could neither identify the author of the writing nor its purpose, the substance of the writing indicates that it contains legal conclusions. The defendants argue that the Special Master reviewed the handwriting and did not err when he concluded that the privilege did not apply to the handwritten entries on 9062 and properly declined to consider Mr. John's Declaration as it was untimely and insufficient.

According to the log, plaintiff [\*58] asserts that the document constitutes work product prepared in anticipation of litigation. The record, however, does not show that it was created for this purpose nor does it establish the author of the handwritten notations. Although the log identifies Michael Casey as the author of the document, the plaintiff concedes that it does not know the identity of the author for handwriting on entry 9062. See Pl. Br. at 24-25. Moreover, entry 9062 does not include handwritten words but rather embodies underlines of words in the text of a published patent. Without the identity of the author and the purpose for which the lines were made, the plaintiff cannot establish that the writings on these documents are privileged.

viii. Entry 1861 (Exhibit K)

The Special Master concluded that log entry 1861 is an undated document without an identified author and nothing on its face shows that it is privileged. Plaintiff states that the Special Master erred in this ruling because, although the plaintiff could neither identify the author of the writing nor its purpose, there is information within the document that suggests that it was drafted by one of IDT's in-house lawyers and the substance indicates that [\*59] the document contains legal advice "on the most likely terms of a" sales transaction. The defendants argue that the Special Master did not err when he concluded that the privilege did not apply to entry 1861 because plaintiff failed to produce evidence to support its claims that the document is privileged.

According to the log, entry 1861 is an undated outline that plaintiff asserts embodies work product and privileged communications with Jim DiGorgio about a VOIP patent. In 2005, Mr. DiGorgio was senior counsel for IDT. Nonetheless, there is no showing that the outline was prepared in anticipation of litigation, no showing that when it was shared with Net2Phone that the plaintiff and IDT had a shared legal interest, and no showing it was authored by an attorney. In fact, according to the log, the author is listed as "NetSpeak Corp." and the plaintiff has conceded that it does not know the identity of the author. See id. at 25. Moreover, the section titled "most likely" does not contain any legal analysis but rather it contains terms of a financial agreement that may be reached. Without the identity of the author and the purpose for which the document was created, the plaintiff cannot [\*60] establish that the document is privileged.

ix. Entry 1864 (Exhibit L)

The Special Master concluded that log entry 1864 is an undated document without an identified author that does not embody privileged communications. Plaintiff states that the Special Master erred in this ruling because, although the plaintiff could neither identify the author of the writing nor its purpose, the substance of the writing indicates that it was prepared by a member of IDT's in-house legal team and contains legal advice "on the most likely terms of a" sales transaction. The defendants argue that the Special Master did not err when he concluded that the privilege did not apply to entry 1864 because plaintiff failed to produce evidence to support its claim that the document is privileged.

According to the log, entry 1864 is identified as having been authored by "IDT" and received by David Greenblatt, an IDT employee, Declaration of Hannah Stotts-Bumstead, dated May 5, 2008, at Ex. 23, that

plaintiff asserts embodies work product and privileged communications with Jim DiGiorgio about the corporation's patent portfolio. Again, plaintiff conceded that it does not know the identity of the author of entry 1864. [\*61] See id. Moreover, there is nothing in the record to show it was prepared in anticipation of litigation and for no other purpose. Lastly, the section titled "most likely" does not contain any privileged material on its face. Instead, it contains terms of a potential financial agreement, including time frame and payment method. Absent proof of the identity of the author and the purpose for which it was created, the plaintiff cannot establish that the document is privileged.

x. Entry 1870 (Exhibit M)

The Special Master concluded that the certification of IDT's in-house counsel attesting to the legal nature of log entry 1870 was insufficient to sustain the privilege assertion because in-house counsel could not identify who marked up the document, when, or why. Plaintiff argues that entry 1870 is a draft of IDT's tender offer that was drafted by IDT's inside and outside lawyers for filing with the Securities and Exchange Commission ["SEC"] and the Special Master erred in failing to credit the declaration of IDT's in-house counsel that asserts that the edits were those of lawyers. The defendants argue that the Special Master did not err when he concluded that the privilege did not apply to [\*62] entry 1870 because the plaintiff provided no evidence as to who marked up the document, when or why.

According to the log, entry 1870 is a draft SEC filing allegedly reflecting communications with the law firm of Kramer Levin. The log describes the author as "Net2Phone, Inc. v NtoP acquisition IDT Corporation." The plaintiff, however, did not present evidence that establishes the author and conceded that it does not know the identity of the author. See id. at 25-26. The plaintiff submitted the Certification of Dov Schwell, Senior Vice President for IDT, dated March 18, 2008, to support its contention that these documents reflect confidential attorney-client communications, Stott-Bumsted Dec. Ex. 20, but it was untimely and will not be considered. Thus, the plaintiff failed to submit timely evidence that identifies the author of these edits. Without the identity of the author of the markings, the plaintiff cannot establish that they are privileged.

xi. Entry 3814 (Exhibit N)

The Special Master concluded that the certification of IDT's in-house counsel attesting to the legal nature of log entry 3814 was insufficient to sustain the privilege assertion because it embodies a communication among [\*63] non-lawyers and the document is not clearly privileged on its face and the declaration submitted did not identify the author of the markings on the document. Plaintiff argues that entry 3814 is a draft of IDT's tender offer that was drafted by IDT's inside and outside lawyers for filing with the SEC and that the Special Master erred in failing to credit the certification of IDT's in-house counsel who attested to the legal nature of entry 3814 even though he could not identify its author. The defendants argue that the Special Master did not err when he concluded that the privilege did not apply to entry 3814 because plaintiff's untimely declaration did not identify if counsel made any of the marks.

According to the log, the draft of the SEC filing is dated November 10, 2005 and the author is identified as a person at "semdd.com" and the recipient is a person at IDT. The plaintiff has conceded that it does not know the identity of the author of the markings on entry 3814. See Pl. Br. at 25-26. Moreover, at the time of these communications, IDT and plaintiff did not share a common legal interest and when the document was shared between them, it lost any privilege status. For these reasons, [\*64] the privilege is not applicable.

xii. Entry 1142 (Exhibit O)

The Special Master concluded that plaintiff failed to present evidence to show that log entry 1142, an email from IDT's in house counsel Jim DiGiorgio to David Greenblatt about the VOIP patents, was privileged and there is no way to tell if it was a privileged communication on its face. Plaintiff argues that, because the email was written by its in house counsel, the only plausible interpretation is that in-house counsel is "proposing a meeting at which he will render legal advice concerning legal action," Pl. Br. at 26, and a corporation's declaration is not needed to establish the privilege. The defendants argue that the Special Master did not err when he concluded that the privilege did not apply to entry 1142 and plaintiff presented no evidence to support its claim of privilege despite having had an opportunity to do so.

Although the log asserts that the email contains legal advice, the face of the document does not support

this description and plaintiff has presented no evidence to show that it was associated with an effort to secure legal advice. The mere fact it was from an attorney, without showing its purpose, is insufficient [\*65] to sustain the privilege since the privilege applies only to communications engaged in for the purpose of securing or providing legal advice. As such, the Special Master's ruling will not be disturbed.

xiii. Entries 1332 & 1333 (Exhibit P)

The Special Master concluded that the plaintiff did not submit evidence that shows log entries 1332-33 are privileged and he could not determine from their face that they embody privileged communications. The plaintiff contends that the portion of the document summarizing a meeting between Binyamin Bauman, a nonlawyer, and the Chairman of IDT's Board of Directors concerning patent enforcement embodies a request for legal advice and is privileged. The defendants argue that the Special Master did not err when he concluded that the privilege did not apply to entries 1332-33 because there is nothing to show that it involves a discussion between non-lawyers reflecting advice of counsel.

According to the log, entries 1332-33 are March 28, 2006 emails from Binyamin Bauman to David Lando, Net2Phone employees, Stott-Bumsted Dec. at Ex. 23, that contain communications with in-house counsel regarding the patent portfolio. The emails, however, were not exchanged [\*66] between attorneys and their contents do not reflect legal advice. Moreover, the plaintiff has submitted no evidence to support its claim of privilege regarding these documents. Thus, the Special Master's conclusion that the documents are not privileged is correct.

xiv. Entry 1337 (Exhibit Q)

The Special Master concluded that entry 1337, a February 21, 2006 email from Philip Florenzo, an attorney in private practice, to David Lando, his client at Net2Phone, see id., forwarding slides prepared by Joseph John, a senior technical advisor in IDT's in-house Intellectual Property group, contains material that is purely factual and is thus not protected by privilege and plaintiff did not timely submit other evidence to establish its claim of privilege. In addition, the Special Master noted that the document was shared with IDT at a time that plaintiff and IDT did not share a common legal interest. The plaintiff asserts that the communication of these facts was for obtaining legal advice and is protected by the attorney-client privilege and that the Declaration of Joseph John explained this was the purpose. The defendants argue that the Special Master did not err when he concluded that the privilege [\*67] did not apply to entry 1337 because he correctly disregarded Mr. John's Declaration and correctly acknowledged that, even if the document were privileged, that privilege had been waived.

According to the log, the plaintiff asserts that the email and attachment reflects legal advice from in-house patent counsel. Even if this were established, the contents actually emanated from an IDT employee during the period before the tender offer had occurred. As stated previously, the common interest doctrine does not protect communications with IDT during this period. Moreover, the only evidence to support the privileged assertion comes in from the untimely submission of the Declaration of Joseph John. See Stott-Bumsted Dec. at 20. Since that evidence is precluded, the plaintiff has failed to timely submit competent evidence to support its privilege claims. As such, the Special Master did not err in concluding that no privilege attached to these documents.

xv. Entries 1840 (Exhibit R)

The Special Master concluded that plaintiff produced no evidence that establishes log entry 1840, a draft of a 2005 operation plan with handwriting, is protected by privilege and nothing on the face of the document [\*68] reveals that it is privileged. Entry 1845 (Exhibit S) is a similar document without handwriting. The plaintiff argues that entry 1840 is a draft presentation by IDT's in-house legal group and contains legal advice and legal services provided in 2005. Plaintiff asserts that the face of the document demonstrates its legal nature, and thus it was not required to provide a declaration to establish that it is privileged. Plaintiff also notes that the Special Master sustained the privilege concerning a similar document. The defendants argue that the Special Master did not err when he concluded that the privilege did not apply to entry 1840 because plaintiff did not present an affidavit concerning the privilege and did not bring to the attention of the Special Master the similarity between 1840 and 1845, even though he allowed plaintiff to move for reconsideration.

According to the log, this document is described as a "presentation" that the IDT Phoenix Group authored. Plaintiff describes it as a privileged communication with Mr. DiGiorgio about patents. Despite this description, the plaintiff has failed to disclose the actual author of the document or handwriting on entry 1840, and indeed [\*69] conceded that it does not know the identity of the author of the handwritings on entry 1840. See Pl. Br. at 27. Moreover, the document is titled "2005 Operating Plan" and does not contain any legal advice. Without the identity of the author or proof that it was created to obtain or convey legal advice, the plaintiff cannot establish that the document is privileged.

xvi. Entry 2783 (Exhibit T)

The Special Master concluded that log entry 2783, an April 2, 2003 email from Anthony Tobey, a member of IDT's information technology staff, to a person associated with IXtelecom, is not privileged because it is between non-lawyers, nothing on its face shows it is privileged, and plaintiff submitted no evidence to establish it is privileged. The plaintiff argues that the first sentence of the email is privileged on its face because it conveys legal advice received from IDT's legal department and thus there is no need for a certification to establish it as privilege. The defendants argue that the Special Master did not err when he concluded that the privilege did not apply to entry 2783 because it involves a communication between non-lawyers and plaintiff failed to supply evidence to show that the [\*70] entry was privileged.

According to the log, plaintiff describes the email as reflecting privileged communications between IDT's business and in-house counsel about the information-technology policy. Despite this entry, the plaintiff concedes that the communication is between non-lawyers. See id. at 28. The plaintiff did not submit any evidence that shows the information relayed between the non-attorneys is legal advice. Moreover, a review of this document shows that it is a group email about the employees' access to external file sharing networks and does not contain legal advice. Thus, the plaintiff has not established that the document is privileged.

xvii. Entry 4562 (Exhibit U)

According to the log, entry 4562 is an email and attachment from Jim DiGiorgio to Luis Diaz that relates to monetizing intellectual property. The Special Master concluded that the plaintiff has waived the privilege relating to the Monetization Plan by its disclosure of documents about the same subject. The plaintiff argues that entry 4562 is an email between two attorneys that contains both non-privileged and privileged information and that the privileged portion should be disclosed but the remainder should [\*71] be shielded because it embodies legal advice to IDT about intellectual property and does not address the Monetization Plan. The defendants argue that the Special Master did not err when he concluded that the privilege did not apply to entry 4562 because this document is within the scope of the waiver and plaintiff concedes the document should have been produced. Pl. Br. at 28.

A review of the document shows that the email merely forwards the attachment and the attachment is a document addressing monetization. For the reasons set forth herein, to the extent a privilege covered this subject, it has been waived. As such, the Special Master's conclusions will not be disturbed here.

xviii. Entries 8832 & 8833 (Exhibit C) (which are contained in entry 8034)

According to the log, entries 8832 and 8833 are January 24, 2005 emails among Jim DiGiorgio, Peter Emanuel, a GE lawyer, and Laurence Rosenberg, a member of GE's Technology Group, which were shared with seven GE staff members about a European patent. Although the Declaration of Kenneth Glick, an attorney for GE, reflects that GE maintained the confidentiality of its internal discussions with counsel and the information it received and shared [\*72] with IDT, see Stott-Bumsted Dec. Ex.18 (attaching the Declaration of Kenneth Glick dated Jan. 14, 2008), the Special Master found that plaintiff failed to timely identify one of the recipients, Ed Howard. Thus, the Special Master concluded that the plaintiff failed to meet its burden of showing based on timely submitted evidence that this email was privileged. The plaintiff argues that the Special Master erred in his conclusion because, in light of Glick's Declaration, it was apparent that the email was confidential and it had timely produced evidence that shows Mr. Howard was a Net2Phone lawyer. The defendants argue that the Special Master did not err when he concluded that the privilege did not apply because the plaintiff failed to meet its burden of proof and because the communications between IDT and GE are not privileged.

The Court concludes that even though the plaintiff timely identified Ed Howard, the contents were shared with GE personnel and, for the reasons already discussed, these communications are not privileged. Thus, the record before the Court shows that the plaintiff failed to meet its burden to withhold the document on privilege grounds.

xix. Entry 9061 (Exhibit C)

For [\*73] the same reasons, the privilege assertion over entry 9061, which is represented to be duplicated in 8834 is overruled.

xx. Entry 9073 (Exhibit V) (redacted versions of already produced materials)

Document entry 9073 is an email dated January 20, 2005 from Arthur Dubroff at Net2Phone to Claude Pupkin and Glenn Williams and copies were provided to Lione Alroy, Michael Pastor, Mitch Silverman, Ken Kaplan and Nicholas Day. These individuals are associated with Net2Phone or IDT. The Special Master concluded that privilege did not apply to the redacted portions of entry 9073 because the plaintiff did not submit any proof the privilege applied and nothing from the face of the document indicated it was privileged. The plaintiff argues that the portions of one paragraph are privileged because it contains communications from Arthur Dubroff to Net2Phone attorneys about actions to be taken with respect to Net2Phone's intellectual property. The defendants argue that the Special Master did not err when he concluded that the privilege did not apply to entry 9073 because the plaintiff failed to meet its burden of proof.

As to entry 9073, this Court finds that the plaintiff fails to meet its burden of [\*74] establishing that this document is privileged with timely produced evidence and therefore the privilege assertion is overruled. Moreover, a review of the document reveals that it does not contain or seek legal advice but rather pertains to valuation of assets. Furthermore, as stated previously, even if it were privileged, the privilege about valuation has been waived and because this document discusses valuation it must be disclosed.

xxi. Entry 4382 (Exhibit W)

The Special Master concluded that privilege did not apply to log entry 4382, a June 18, 2004 email and attachment from Pat Gartner to Luis Diaz, an IDT attorney, because it forwarded as an attachment drawings created by a non-lawyer that do not appear privileged on their face. Moreover, although the log states the email and attachment discuss obtaining legal advice about intellectual property, the Special Master concluded that the Declaration of Luis Diaz did not address this document, no timely evidence was adduced to support the privilege claim, and he refused to consider the untimely submissions purported to support plaintiff's assertion of privilege. The plaintiff argues that, because the document was sent to an attorney, [\*75] it is only plausible to conclude that it was sent in connection with a request for legal advice about an intellectual property matter and the declaration of Mr. Gartner supports this conclusion. The defendants argue that the Special Master did not err when he declined to consider the untimely evidence and in any event, it did not address the document and the plaintiff did not prove that the privilege applies to entry 4382. The defendants also argue that any argument that is nonresponsive to any discovery demand cannot be a basis to object to the privilege ruling because this is not an issue ripe for resolution in this context.

This Court finds that the timely submission of Luis Diaz's Declaration does not satisfy its burden because Mr. Diaz's Declaration does not address this document. Moreover, the Court will not consider plaintiff's untimely submissions. Finally, a review of the document reflects it embodies factual information and does not on its face reflect legal advice. As such, the plaintiff has failed to meet its burden to show that the document is covered by the attorney-client privilege.

xxii. Additional Entries

Neither party's submission addresses the Special Master's decision [\*76] regarding privilege to log entries 4638-39, 4675, 3893, and 1766. As such, the Court will deem any objections thereto waived and the Court will not address the Special Master's decision on these documents.

E. Motion to Seal

The plaintiff seeks to seal certain documents submitted in connection with its objections to the Special Master's Report. Plaintiff has not demonstrated that these documents warrant sealing. First, the Special Master's Report was publicly filed without opposition by the plaintiff and discloses information the plaintiff now seeks to seal. Second, the communications the plaintiff's seeks to seal relate to matters that occurred several years ago and thus the need to seal what may have been confidential information no longer exists as there is no showing that there would be present harm from disclosure. Lastly, to the extent the request to seal is made to preserve the confidential nature of alleged privileged documents, the assertion of privilege has been overruled and the need for confidentiality for this purpose is moot. Thus, plaintiff's motion to seal the documents in connection with the objection is denied.

### III. Conclusion

For the foregoing reasons, the Special Master's [\*77] findings of fact, conclusions of law, and procedural determinations are affirmed in their entirety and plaintiff's motion to seal is denied. The plaintiff shall produce the withheld documents no later than June 30, 2008.

/s/ Patty Shwartz

United States Magistrate Judge

Date: June 25, 2008

### ORDER

This matter having come before the Court on the plaintiff's objections to the Special Master's Report issued on April 21, 2008 and plaintiff's motion to seal the documents submitted in connection with its objections;

and the Court having considered the parties submissions;

and the Court having decided this motion without oral argument pursuant to Fed. R. Civ. P. 78 and L. Civ. R. 78.1;

and for the reasons set forth in the Opinion dated June 25, 2008;

IT IS ON THIS 25th day of June, 2008,

ORDERED that the Special Master's Report is affirmed in its entirety and the objections [Docket No. 219] are overruled;

IT IS FURTHER ORDERED that the plaintiff shall produce the documents consistent with the Special Master's Report no later than **June 30, 2008**; and

IT IS FURTHER ORDERED that the plaintiff's motion to seal [Docket No. 222] is denied.

/s/ Patty Shwartz

UNITED STATES MAGISTRATE JUDGE



Source: [Command Searching](#) > Patent Cases from Federal Courts and Administrative Materials 

Terms: 6108704 or 6,108,704 ([Edit Search](#) | [Suggest Terms for My Search](#))

View: Full

Date/Time: Monday, May 3, 2010 - 12:37 PM EDT

#### \* Signal Legend:

-  - Warning: Negative treatment is indicated
-  - Questioned: Validity questioned by citing refs
-  - Caution: Possible negative treatment

- ◆ - Positive treatment is indicated
- Ⓐ - Citing Refs. With Analysis Available
- Ⓘ - Citation information available

\* Click on any *Shepard's* signal to *Shepardize*® that case.

[My Lexis™](#) | [Search](#) | [Research Tasks](#) | [Get a Document](#) | [Shepard's®](#) | [Alerts](#) | [Total Litigator](#) | [Transactional Advisor](#) | [Counsel Selector](#)  
[History](#) | [Delivery Manager](#) | [Switch Client](#) | [Preferences](#) | [Sign Out](#) | [Help](#)

 LexisNexis® [About LexisNexis](#) | [Terms & Conditions](#) | [Contact Us](#)  
Copyright © 2010 LexisNexis, a division of Reed Elsevier Inc. All rights reserved.

Command Searching > Patent, Trademark & Copyright Periodicals, Combined

Search

Select Search Type and Enter Search Terms

Terms & Connectors	6108704 or 6,108,704
Natural Language	
Easy Search <sup>™</sup>	

Suggest terms for my search

[Check spelling](#)

Restrict by Document Segment

Select a document segment, enter search terms for the segment, then click Add.

Select a Segment  Add

Note: Segment availability differs between sources. Segments may not be applied consistently across sources.

Restrict by Date

No Date Restrictions  From  To  [Date formats...](#)

Search Connectors

- [and](#) and [w/p](#) in same paragraph
- [or](#) or [w/seg](#) in same segment
- [w/N](#) within N words [w/s](#) in same sentence
- [pre/N](#) precedes by N words [and not](#) and not

> [More Connectors & Commands...](#)

How Do I...?

- > [Combine sources?](#)
- > [Restrict by date?](#)
- > [Restrict by document segment?](#)
- > [Use wildcards as placeholders for one or more characters in a search term?](#)

[View Tutorials](#)



## No Documents Found

No documents were found for your search terms

"6108704 or 6,108,704"

---

Click "Save this search as an Alert" to schedule your search to run in the future.

- OR -

Click "Edit Search" to return to the search form and modify your search.

### Suggestions:

- Check for spelling errors .
  - Remove some search terms.
  - Use more common search terms, such as those listed in "Suggested Words and Concepts"
  - Use a less restrictive date range.
- 

Save this Search as an Alert

Edit Search



LexisNexis®

[About LexisNexis](#) | [Terms & Conditions](#) | [Contact Us](#)

Copyright © 2010 LexisNexis, a division of Reed Elsevier Inc. All rights reserved.

Command Searching > News, All (English, Full Text) ⓘ

Search ⓘ

Select Search Type and Enter Search Terms

Terms & Connectors	6108704 or 6,108,704
Natural Language	
Easy Search™	

Suggest terms for my search

Check spelling

Restrict by Document Segment

Select a document segment, enter search terms for the segment, then click Add.

Select a Segment  Add ↑

Note: Segment availability differs between sources. Segments may not be applied consistently across sources.

Restrict by Date

No Date Restrictions  From  To  Date formats...

Search Connectors

- and · and      w/p      in same paragraph
- or      or      w/seg      in same segment
- w/N      within N words      w/s      in same sentence
- pre/N      precedes by N words      and,not      and not
- > [More Connectors & Commands...](#)

How Do I...?

- > [Combine sources?](#)
- > [Restrict by date?](#)
- > [Restrict by document segment?](#)
- > [Use wildcards as placeholders for one or more characters in a search term?](#)

[View Tutorials](#)

FOCUS™ Terms 6108704 or 6,108,704 Search Within Original Results (1 - 3) Go Advanced...

Source: Command Searching > News, All (English, Full Text)
Terms: 6108704 or 6,108,704 (Edit Search | Suggest Terms for My Search)

Select for FOCUS™ or Delivery

1. GlobalAdSource (English), February 9, 2007 Friday, 29 words, UNPRECEDENTED FROM ANY ANGLE ... ID 6108704 ...

2. vnunet.com, 6 June 2006 Tuesday, 167 words, Skype under fire over Net2Phone patent, Matt Chapman

CORE TERMS: Skype, lawsuit, Net2Phone's, VoIP, patent, eBay, direct connection ... 2000. US Patent 6,108,704 covers the technology that allows ...

3. News Release, February 27, 1996, 6108704, 211 words, New Teradyne Third-Party Supplier Program for Programming & Fixture Houses

CORE TERMS: Teradyne, TSN, Z1800-Series, programming, extensive, fixture

Source: Command Searching > News, All (English, Full Text)
Terms: 6108704 or 6,108,704 (Edit Search | Suggest Terms for My Search)

View: Cite

Date/Time: Monday, May 3, 2010 - 12:38 PM EDT

<b>INFORMATION DISCLOSURE STATEMENT BY APPLICANT</b> FORM PTO-1449 (modified)	Reexam number	90/010,416
	First Named Inventor	Hutton
	Patent Under Re-Exam	6108704
	Issue Date	2000/08/22
	Group Art Unit	3992
	Examiner Name	KOSOWSKI, ALEXANDER J
	Attorney Docket No.	2655-0188
	Confirmation No.	1061

Sheet 1 of 1

NON-PATENT REFERENCES			
Examiner Initials*	Cite No.	Non-patent Reference bibliographic information, where available	Notes
	1-1	Notice Of Motion To Transfer Venue To The Western District of Arkasas, Civ. Action No. 06-2469	
	1-2	Reply Brief In Further Support Of Net2Phone's Motion To Transfer Venue To The Western District Of Arkansas, Civ. Action No. 06-2469	
	1-3		
	1-4		
	1-5		
	1-6		
	1-7		

Examiner Signature		Date Considered	
--------------------	--	-----------------	--

\*Examiner Initial if reference was considered, whether or not citation is in conformance with MPEP 609. Draw a line through citation if not in conformance and not considered. Include a copy of this form with next communication to applicant. Notes: If identified, the following is provided: EA = English Abstract, T = Translation, PT = Partial Translation, SOR = Statement of Relevancy, PF = Patent Family.

## Electronic Acknowledgement Receipt

<b>EFS ID:</b>	7566674
<b>Application Number:</b>	90010416
<b>International Application Number:</b>	
<b>Confirmation Number:</b>	1061
<b>Title of Invention:</b>	Point-to-Point Internet Protocol
<b>First Named Inventor/Applicant Name:</b>	6108704
<b>Customer Number:</b>	42624
<b>Filer:</b>	Michael R. Casey
<b>Filer Authorized By:</b>	
<b>Attorney Docket Number:</b>	2655-0188
<b>Receipt Date:</b>	06-MAY-2010
<b>Filing Date:</b>	17-FEB-2009
<b>Time Stamp:</b>	18:00:25
<b>Application Type:</b>	Reexam (Third Party)

### Payment information:

Submitted with Payment	no
------------------------	----

### File Listing:

Document Number	Document Description	File Name	File Size(Bytes)/ Message Digest	Multi Part /.zip	Pages (if appl.)
1	Transmittal Letter	20100506_0188_IDS.pdf	133586 <small>bedd3f4b0615b1a22cd388e51911a60dd0b2e56d</small>	no	2

### Warnings:

2	NPL Documents	NP0000.pdf	102125 a7d17c07971330af903f13907088be7b3d2b1e0d	no	19
<b>Warnings:</b>					
<b>Information:</b>					
3	NPL Documents	NP0001.pdf	545041 63514a7badbf524502040085964c36bbfa03fe99	no	78
<b>Warnings:</b>					
<b>Information:</b>					
4	Reexam Certificate of Service	20100506_0188_COS.pdf	57284 a5b35fd2692797797c774166e98d09baea b10c5	no	1
<b>Warnings:</b>					
<b>Information:</b>					
5	Information Disclosure Statement (IDS) Filed (SB/08)	20100506_0188_1449.pdf	127614 861b8197f32cc8111fe13cd644b8e656811557e5	no	1
<b>Warnings:</b>					
<b>Information:</b>					
This is not an USPTO supplied IDS fillable form					
<b>Total Files Size (in bytes):</b>				965650	
<p>This Acknowledgement Receipt evidences receipt on the noted date by the USPTO of the indicated documents, characterized by the applicant, and including page counts, where applicable. It serves as evidence of receipt similar to a Post Card, as described in MPEP 503.</p> <p><b><u>New Applications Under 35 U.S.C. 111</u></b>  If a new application is being filed and the application includes the necessary components for a filing date (see 37 CFR 1.53(b)-(d) and MPEP 506), a Filing Receipt (37 CFR 1.54) will be issued in due course and the date shown on this Acknowledgement Receipt will establish the filing date of the application.</p> <p><b><u>National Stage of an International Application under 35 U.S.C. 371</u></b>  If a timely submission to enter the national stage of an international application is compliant with the conditions of 35 U.S.C. 371 and other applicable requirements a Form PCT/DO/EO/903 indicating acceptance of the application as a national stage submission under 35 U.S.C. 371 will be issued in addition to the Filing Receipt, in due course.</p> <p><b><u>New International Application Filed with the USPTO as a Receiving Office</u></b>  If a new international application is being filed and the international application includes the necessary components for an international filing date (see PCT Article 11 and MPEP 1810), a Notification of the International Application Number and of the International Filing Date (Form PCT/RO/105) will be issued in due course, subject to prescriptions concerning national security, and the date shown on this Acknowledgement Receipt will establish the international filing date of the application.</p>					

IN THE UNITED STATES PATENT AND TRADEMARK OFFICE

In re PATENT APPLICATION OF:

Net2Phone, Inc. (Patent No. 6,108,704)

Control No.: 90/010,416

Issue Date: August 22, 2000

Title: **POINT-TO-POINT INTERNET  
PROTOCOL**

Attorney Docket: 2655-0188

Group Art Unit: 3992

Examiner: KOSOWSKI, Alexander

Date: May 6, 2010

Confirmation No.: 1061

INFORMATION DISCLOSURE STATEMENT

Hon. Commissioner of Patents  
P.O. Box 1450  
Alexandria, VA 22313-1450

Sir:

Pursuant to 37 C.F.R. § 1.56, the attention of the Patent and Trademark Office is hereby directed to the reference(s) listed on the attached PTO-1449. One copy of each non-U.S. Patent reference is attached. It is respectfully requested that the information be expressly considered during the prosecution of this application, and that the reference(s) be made of record therein and appear among the "References Cited" on any patent to issue therefrom.

The submission of any document herewith, which is not a statutory bar, is not intended that any such document constitutes prior art against any of the claims of the present application or is considered to be material to patentability as defined in 37 C.F.R. § 1.56(b). Applicants do not waive any rights to take any action which would be appropriate to antedate or otherwise remove as a competent reference against the claims of the present application.

The Opposition to the enclosed Motion will be filed under separate cover.

**CHARGE STATEMENT: Deposit Account No. 501860, order no. 2655-0188.**

The Commissioner is hereby authorized to charge any fee specifically authorized hereafter, or any missing or insufficient fee(s) filed, or asserted to be filed, or which should have been filed herewith or concerning any paper filed hereafter, and which may be required under Rules 16-18 (missing or insufficiencies only) now or hereafter relative to this application and the resulting Official Document under Rule 20, or credit any overpayment, to our Accounting/Order Nos. shown above, for which purpose a duplicate copy of this sheet is attached

**This CHARGE STATEMENT does not authorize charge of the issue fee until/unless an issue fee transmittal sheet is filed.**

CUSTOMER NUMBER

**42624**

Respectfully submitted,

Davidson Berquist Jackson & Gowdey LLP  
4300 Wilson Blvd., 7th Floor,  
Arlington Virginia 22203  
Main: (703) 894-6400 • FAX: (703) 894-6430

By: / Michael R. Casey /

Michael R. Casey, Ph.D. (Reg. No.: 40,294)



**CERTIFICATE OF SERVICE**

The undersigned hereby certifies that, on May 6, 2010, the undersigned will cause the Information Disclosure Statement filed in Re-examination Control No. 90/010,416 to be served by U.S. First Class Mail, postage prepaid, on Requestor as follows:

Blakely, Sokoloff, Taylor & Zafman LLP  
1279 Oakmead Parkway  
Sunnyvale, CA 94085-4040

Per agreement with the requester, copies of the references were included in electronic format on CD-ROM.

/ Michael R. Casey /

---

Michael R. Casey, Ph.D.



UNITED STATES PATENT AND TRADEMARK OFFICE

UNITED STATES DEPARTMENT OF COMMERCE  
United States Patent and Trademark Office  
Address: COMMISSIONER FOR PATENTS  
P.O. Box 1450  
Alexandria, Virginia 22313-1450  
www.uspto.gov

APPLICATION NO.	FILING DATE	FIRST NAMED INVENTOR	ATTORNEY DOCKET NO.	CONFIRMATION NO.
90/010,416	02/17/2009	6108704	2655-0188	1061

42624 7590 05/11/2010

DAVIDSON BERQUIST JACKSON & GOWDEY LLP  
4300 WILSON BLVD., 7TH FLOOR  
ARLINGTON, VA 22203

EXAMINER

ART UNIT PAPER NUMBER

DATE MAILED: 05/11/2010

Please find below and/or attached an Office communication concerning this application or proceeding.



**DO NOT USE IN PALM PRINTER**

(THIRD PARTY REQUESTER'S CORRESPONDENCE ADDRESS)

Blakely Sokoloff Taylor & Zafman LLP

1279 Oakmead Parkway

Sunnyvale, CA 94085-4040

**EX PARTE REEXAMINATION COMMUNICATION TRANSMITTAL FORM**

REEXAMINATION CONTROL NO. 90/010,416.

PATENT NO. 6108704.

ART UNIT 3992.

Enclosed is a copy of the latest communication from the United States Patent and Trademark Office in the above identified *ex parte* reexamination proceeding (37 CFR 1.550(f)).

Where this copy is supplied after the reply by requester, 37 CFR 1.535, or the time for filing a reply has passed, no submission on behalf of the *ex parte* reexamination requester will be acknowledged or considered (37 CFR 1.550(g)).



Art Unit: 3992

### DETAILED ACTION

1) This Office action addresses claims 1-7 and 10-44 of United States Patent Number 6,108,704 (Hutton et al), for which it has been determined in the Order Granting Ex Parte Reexamination (hereafter the "Order") mailed 3/11/09 that a substantial new question of patentability was raised in the Request for *Ex Parte* reexamination filed on 2/17/09 (hereafter the "Request"). Claims 8-9 are not subject to reexamination. This is a final office action in response to the amendment filed 11/27/09. The rejection of claims 44-45 is maintained below. All other previously rejected claims are confirmed below.

### IDS

2) With regard to the IDS's filed 12/14/09, 12/21/09, 1/26/10, 2/24/10, 3/5/10, 5/6/10:

Where the IDS citations are submitted but not described, the examiner is only responsible for cursorily reviewing the references. The initials of the examiner on the PTO-1449 indicate only that degree of review unless the reference is either applied against the claims, or discussed by the examiner as pertinent art of interest, in a subsequent office action. See Guidelines for Reexamination of Cases in View of *In re Portola Packaging, Inc.*, 110 F.3d 786, 42 USPQ2d 1295 (Fed. Cir. 1997), 64 FR at 15347, 1223 Off. Gaz. Pat. Office at 125 (response to comment 6).

Consideration by the examiner of the information submitted in an IDS means that the examiner will consider the documents in the same manner as other documents in Office search files are considered by the examiner while conducting a search of the prior art in a proper field of search. The initials of the examiner placed adjacent to the citations on the PTO-1449 or PTO/SB/08A and 08B or its equivalent mean that the information has been considered by the examiner to the extent noted above.

Regarding IDS submissions MPEP 2256 recites the following: "Where patents, publications, and other such items of information are submitted by a party (patent owner or requester) in compliance with the requirements of the rules, the requisite degree of consideration to be given to such information will be normally limited by the degree to which the party filing the information citation has explained the content and relevance of the information."

Accordingly, the IDS submissions have been considered by the Examiner only with the scope required by MPEP 2256, unless otherwise noted.

In addition, that which are not either prior art patents or prior art printed publications have been crossed out so as not to appear reprinted on the front page of the patent.

*Claim Rejection Paragraphs*

3) *Claim Rejections - 35 USC § 102*

The following is a quotation of the appropriate paragraphs of 35 U.S.C. 102 that form the basis for the rejections under this section made in this Office action:

A person shall be entitled to a patent unless –

(b) the invention was patented or described in a printed publication in this or a foreign country or in public use or on sale in this country, more than one year prior to the date of application for patent in the United States.

*Issue 1*

4) Claims 43-44 are rejected under 35 U.S.C. 102(b) as being unpatentable by NetBIOS  
(See claim mapping chart in Exhibit M, pages 36-40, incorporated by reference).

*Issue 2*

5) Examiner notes the following will represent the Etherphone references utilized for the rejection below (All considered a single reference as published together):

*"Zellweger"*: An Overview of the Etherphone System and its Applications

*"Swinehart"*: Telephone Management in the Etherphone System

*"Terry"*: Managing Stored Voice in the Etherphone System

*"Swinehart 2"*: System Support Requirements for Multi-media Workstations

*"Zellweger 2"*: Active Paths through Multimedia Documents

6) Claims 43-44 are rejected under 35 U.S.C. 102(b) as being unpatentable by Etherphone  
(See claim mapping chart in Exhibit N, pages 33-35, incorporated by reference).

*Response to Arguments*

7) In response to the amendment filed 11/27/09, some rejections are sustained as noted above, and others have been withdrawn. The following aspects of the current prosecution will be addressed as noted below:

- a) VocalChat are not printed publications.
- b) The 1.132 Declaration
- c) Objective evidence of non-obviousness
- d) Withdrawn rejections
- e) Maintained rejections

a) The amendment submitted 11/27/09 includes arguments that the VocalChat references are not printed publications. The Patent Owner (PO) cites exhibit L of the Request (the declaration of Alon Cohen) as the only evidence provided by PO that the VocalChat references are printed publications. Examiner notes that the Alon Cohen declaration fails to comply with 37 C.F.R. 1.68, including not setting forth in the body of the declaration that all statements made of the declarant's own knowledge are true and that all statements made on information and belief are believed to be true. Therefore, PO's arguments questioning the declaration as well as whether printed publication status has been established as set forth under statute are found persuasive. Examiner therefore withdraws all rejections utilizing the VocalChat references.

Art Unit: 3992

- b) Examiner notes that all evidence presented has been considered in its entirety, including both PO's arguments, including secondary considerations, as well as the 1.132 Declaration submitted by expert Ketan Mayer-Patel.
- c) Examiner notes that PO's arguments regarding objective evidence of non-obviousness, including commercial success and failure of others have been considered, however no nexus has been provided between the claimed invention and the submitted evidence as required by at least MPEP 716.03. Therefore, this evidence is not found persuasive.
- d) In light of PO's arguments and amendments filed 11/27/09, as well as the declaration of expert Mayer-Patel, examiner withdraws the rejections of claims 1-7 and 10-42. Examiner finds the presented arguments to be persuasive.

With regard to the NetBios rejection, examiner agrees with declarant Mayer-Patel that bringing dynamic addressing into a NetBIOS type system would create a new set of obstacles that would need to be solved that are not obvious in view of the combination of references. In addition, examiner notes with regard to the rejection of claims 10-31 that NetBIOS does not necessarily inherently include a "user interface", and support for such inherency is not currently of record. In addition, amended claims 11 and 22 (previously 10 and 21) now require the dynamic addressing aspects of the other claims 1-7 and 10-42.

With regard to the rejection under Etherphone, examiner agrees with declarant Mayer-Patel that the Etherphone system, which utilizes a datagram multicast, would not be obviously



Art Unit: 3992

combinable with DHCP due to expiration of address leases. In addition, amended claims 11 and 22 (previously 10 and 21) now require the dynamic aspects of the other claims 1-7 and 10-42.

A reasons for confirmation for the claims discussed above will follow in a subsequent office action.

e) The rejection of claims 43-44 are maintained in view of NetBIOS and Etherphone.

With regard to the rejection under NetBIOS, maintained above:

PO first argues with regard to claim 43 that NetBIOS does not teach that "the processes receive network protocol address 'following connection to the computer network'". However, examiner notes that this limitation is not required by the current claim language. Claim 43 recites "the network protocol address forwarded to the database following connection to the computer network". This claim language implies that the computer may already have an IP address before connecting to the server. Examiner notes, for example, that claim 1 requires *receiving* a network protocol address "following connection to the computer network". Claim 43 does not require this. Examiner notes that the original rejection was meant to be a rejection under 35 U.S.C. 102(b), despite PO attempting to argue a rejection under 35 U.S.C. 103(a) which was not made. As claim 43 does not require the same DHCP aspects as other independent claims, the arguments are therefore not found persuasive in view of declarant Mayer-Patel.

PO secondly argues with regard to claim 43 that NetBIOS does not teach a database "having a network protocol address for a selected plurality of processes having on-line status with respect to the computer network". PO argues that having an "active name" is not synonymous with an "on-line status", and that an "active name" simply refers to "a name that has

Art Unit: 3992

been registered and that has not yet been de-registered". However, examiner notes that PO's specification at col. 5 lines 39-44 teaches that the on-line status information may not always be current, and may be updated, for example, only every 24 hours based on operator configuration. Therefore, the database of NetBIOS which contains active name information reads on claim 43, whether or not the user data is current.

With regard to claim 44, PO argues similar to the dynamic addressing argument above with regard to claim 43. Claim 44 also recites "forwarding" rather than "receiving" an address. Therefore, referring to claim 44, see the response to arguments for claim 43 above.

PO also argues with regard to claim 44 that NetBIOS does not teach that an "active name" is synonymous with "whether the second process is connected to the computer network". As noted by examiner above with regard to claim 43, NetBIOS teaches that a process has connected and was active. There is no claim requirement that the database be current based on PO's specification.

With regard to the rejection under Etherphone, maintained above:

PO argues with regard to claim 43 that Figure 3 of Zelleweger1 "does not show that the cited database includes the claimed "network protocol address". In response, examiner notes that Figure 3 references a user interface aspect of Etherphone. This is separate from the hardware workings of the system. Swinehart1, page 4, clearly teaches that the "voice control server manages voice switching by sending to each Etherphone or service the network addresses of the other participants". Therefore, the database contains the required network protocol addresses.

Art Unit: 3992

Next, PO argues that Etherphone does not disclose the required dynamic addressing. In response, examiner notes the response to NetBIOS above. Dynamic addressing is not required in the claim language of claim 43.

With regard to claim 44, PO argues that no citation has been made regarding a query being sent to an address server. Examiner notes that given a broadest reasonable interpretation, an address server is merely a server that can hold a database of addresses. The term does not specifically require the server to perform DHCP functionality. Zelleweger I, page 3, clearly teaches the use of remote procedure calls to a server for establishing connections between two parties, which reads on the claimed limitation.

Therefore, the current arguments regarding claims 43-44 are not persuasive, and the rejections above are maintained.

*Conclusion*

**THIS ACTION IS MADE FINAL.**

**Extensions of time under 37 CFR 1.136(a) do not apply in reexamination proceedings.** The provisions of 37 CFR 1.136 apply only to "an applicant" and not to parties in a reexamination proceeding. Further, in 35 U.S.C. 305 and in 37 CFR 1.550(a), it is required that reexamination proceedings "will be conducted with special dispatch within the Office."

**Extensions of time in reexamination proceedings are provided for in 37 CFR 1.550(c).** A request for extension of time must be filed on or before the day on which a response to this action is due, and it must be accompanied by the petition fee set forth in 37 CFR 1.17(g). The mere filing of a request will not effect any extension of time. An extension of time will be granted only for sufficient cause, and for a reasonable time specified.

The filing of a timely first response to this final rejection will be construed as including a request to extend the shortened statutory period for an additional month, which will be granted even if previous extensions have been granted. In no event however, will the statutory period for response expire later than SIX MONTHS from the mailing date of the final action. See MPEP § 2265.

All correspondence relating to this ex parte reexamination proceeding should be directed as follows:

By U.S. Postal Service Mail to:

Mail Stop Ex Parte Reexam

Art Unit: 3992

ATTN: Central Reexamination Unit  
Commissioner for Patents  
P.O. Box 1450  
Alexandria, VA 22313-1450

By FAX to:

(571) 273-9900  
Central Reexamination Unit

By hand to:

Customer Service Window  
Randolph Building  
401 Dulany St.  
Alexandria, VA 22314

By EFS-Web:

Registered users of EFS-Web may alternatively submit such correspondence via the electronic filing system EFS-Web, at

<https://sportal.uspto.gov/authenticate/authenticateuserlocalepf.html>

EFS-Web offers the benefit of quick submission to the particular area of the Office that needs to act on the correspondence. Also, EFS-Web submissions are "soft scanned" (i.e., electronically uploaded) directly into the official file for the reexamination proceeding, which offers parties the opportunity to review the content of their submissions after the "soft scanning" process is complete.

Any inquiry concerning this communication or earlier communications from the Reexamination Legal Advisor or Examiner, or as to the status of this proceeding, should be directed to the Central Reexamination Unit at telephone number (571) 272-7705.

/Alexander J Kosowski/

Primary Examiner, Art Unit 3992

JK  
ESK

<b>INFORMATION DISCLOSURE STATEMENT BY APPLICANT</b> FORM PTO-1449 (modified)	Reexam number	90/010,416
	First Named Inventor	Hutton
	Patent Under Re-Exam	6108704
	Issue Date	2000/08/22
	Group Art Unit	3992
	Examiner Name	KOSOWSKI, ALEXANDER J
	Attorney Docket No.	2655-0188
	Confirmation No.	1061
Sheet 1 of 30		

**U.S. PATENT DOCUMENTS**

Examiner Initials*	Cite No.	Document No.	Publication/ Issue Date	Name of Patentee or Applicant of Cited Document
	1-1	US-2003/0050075	2003/13/03	Rangarajan et al.
	1-2	US-2004/0204146	2004/14/10	Deeds
	1-3	US-2005/0032435	2005/10/02	Tischer et al.
	1-4	US-2005/0130611	2005/16/06	Lu et al.
	1-5	US-4332982	1982/01/06	Thomas
	1-6	US-4410765	1983/13/10	Hestad et al.
	1-7	US-4446519	1984/01/05	Thomas
	1-8	US-4450554	1984/22/05	Steensma, et al.
	1-9	US-4468529	1984/28/08	Samuel et al.
	1-10	US-4528659	1985/09/07	Jones, Jr.
	1-11	US-4589107	1986/13/05	Middleton, et al.
	1-12	US-4594477	1986/10/06	Noirot
	1-13	US-4598397	1986/01/07	Nelson, et al.
	1-14	US-4630262	1986/16/12	Callens, et al.
	1-15	US-4652703	1987/24/03	Lu, et al.
	1-16	US-4654483	1987/03	Imai et al.
	1-17	US-4694492	1987/09	Wirstrom et al.
	1-18	US-4740963	1988/26/04	Eckley
	1-19	US-4782485	1988/01/11	Gollub
	1-20	US-4799153	1989/01	Hann et al.
	1-21	US-4809271	1989/28/02	Kondo, et al.
	1-22	US-4813040	1989/14/03	Futato
	1-23	US-4819228	1989/04/04	Baran, et al.
	1-24	US-4821263	1989/04	Lundh

Examiner Signature	/Alexander Kosowski/	Date Considered	05/03/2010
--------------------	----------------------	-----------------	------------

\*Examiner. Initial if reference was considered, whether or not citation is in conformance with MPEP 609. Draw a line through citation if not in conformance and not considered. Include a copy of this form with next communication to applicant.

<b>INFORMATION DISCLOSURE STATEMENT BY APPLICANT</b> FORM PTO-1449 (modified)	Reexam number	90/010,416
	First Named Inventor	Hutton
	Patent Under Re-Exam	6108704
	Issue Date	2000/08/22
	Group Art Unit	3992
	Examiner Name	KOSOWSKI, ALEXANDER J
	Attorney Docket No.	2655-0188
	Confirmation No.	1061
Sheet 2 of 30		

U.S. PATENT DOCUMENTS				
Examiner Initials*	Cite No.	Document No.	Publication/ Issue Date	Name of Patentee or Applicant of Cited Document
	2-1	US-4829554	1989/09/05	Barnes et al.
	2-2	US-4837797	1989/06	Freeny, Jr., Charles C.
	2-3	US-4866704	1989/12/09	Bergman
	2-4	US-4866732	1989/12/09	Carey, et al.
	2-5	US-4873715	1989/10/10	Shibata
	2-6	US-4887265	1989/12/12	Felix
	2-7	US-4890282	1989/26/12	Lambert, et al.
	2-8	US-4912705	1990/27/03	Paneth, et al.
	2-9	US-4932022	1990/05/06	Keeney, et al.
	2-10	US-4981371	1991/01/01	Gurak, et al.
	2-11	US-4989230	1991/29/01	Gillig et al.
	2-12	US-4995074	1991/02	Goldman et al.
	2-13	US-5031089	1991/07	Liu et al.
	2-14	US-5036513	1991/30/07	Greenblatt
	2-15	US-5040141	1991/13/08	Yazima et al
	2-16	US-5056140	1991/10	Kimbell
	2-17	US-5065425	1991/12/11	Lecomte, et al.
	2-18	US-5107443	1992/04	Smith et al.
	2-19	US-5121385	1992/09/06	Tominaga, et al.
	2-20	US-5127003	1992/30/06	Dell Jr. et al
	2-21	US-5130985	1992/14/07	Kondo, et al.
	2-22	US-5150410	1992/22/09	Bertrand
	2-23	US-5155726	1992/13/10	Spinney, et al.
	2-24	US-5157592	1992/20/10	Walters

Examiner Signature		Date Considered	
--------------------	--	-----------------	--

\*Examiner: Initial if reference was considered, whether or not citation is in conformance with MPEP 609. Draw a line through citation if not in conformance and not considered. Include a copy of this form with next communication to applicant.

<b>INFORMATION DISCLOSURE STATEMENT BY APPLICANT</b> FORM PTO-1449 (modified)	Reexam number	90/010,416
	First Named Inventor	Hutton
	Patent Under Re-Exam	6108704
	Issue Date	2000/08/22
	Group Art Unit	3992
	Examiner Name	KOSOWSKI, ALEXANDER J
	Attorney Docket No.	2655-0188
	Confirmation No.	1061
Sheet 3 of 30		

U.S. PATENT DOCUMENTS				
Examiner Initials*	Cite No.	Document No.	Publication/ Issue Date	Name of Patentee or Applicant of Cited Document
	3-1	US-5187591	1993/16/02	Guy, et al.
	3-2	US-5212789	1993/18/05	Rago
	3-3	US-5214650	1993/25/05	Renner, et al.
	3-4	US-5220599	1993/06	Sasano et al
	3-5	US-5241594	1993/31/08	Kung
	3-6	US-5241625	1993/08	Epard et al.
	3-7	US-5247620	1993/09/21	Fukuzawa et al.
	3-8	US-5249290	1993/28/09	Heizer
	3-9	US-5274635	1993/12	Rahman et al.
	3-10	US-5282197	1994/25/01	Kreitzer
	3-11	US-5283819	1994/01/02	Glick, et al.
	3-12	US-5287103	1994/15/02	Kasprzyk Marlon Z et al
	3-13	US-5305312	1994/19/04	Fornek, et al.
	3-14	US-5327486	1994/07	Wolff et al.
	3-15	US-5335276	1994/02/08	Thompson et al.
	3-16	US-5341374	1994/23/08	Lewen et al.
	3-17	US-5347632	1994/09	Filepp et al.
	3-18	US-5377260	1994/12	Long
	3-19	US-5396485	1995/03	Ohno et al.
	3-20	US-5410754	1994/15/02	Favreau Keith et al
	3-21	US-5428608	1995/06	Freeman et al.
	3-22	US-5432846	1995/11/07	Norio
	3-23	US-5440547	1995/08/08	Esaki Hiroshi et al
	3-24	US-5446891	1995/29/08	Kaplan et al.

Examiner Signature		Date Considered	
--------------------	--	-----------------	--

\*Examiner: Initial if reference was considered, whether or not citation is in conformance with MPEP 609. Draw a line through citation if not in conformance and not considered. Include a copy of this form with next communication to applicant.



<b>INFORMATION DISCLOSURE STATEMENT BY APPLICANT</b> FORM PTO-1449 (modified)	Reexam number	90/010,416
	First Named Inventor	Hutton
	Patent Under Re-Exam	6108704
	Issue Date	2000/08/22
	Group Art Unit	3992
	Examiner Name	KOSOWSKI, ALEXANDER J
	Attorney Docket No.	2655-0188
	Confirmation No.	1061
Sheet 4 of 30		

U.S. PATENT DOCUMENTS				
Examiner Initials*	Cite No.	Document No.	Publication/ Issue Date	Name of Patentee or Applicant of Cited Document
	4-1	US-5446919	1995/29/08	Wilkins
	4-2	US-5457738	1995/10/10	Sylvan
	4-3	US-5459864	1995/10	Brent et al.
	4-4	US-5461611	1995/10	Drake, Jr. et al.
	4-5	US-5465286	1995/07/11	Clare et al.
	4-6	US-5467388	1995/11	Redd et al.
	<del>4-7</del>	<del>US-5473531</del>	<del>1995/10</del>	<del>Flora-Holmquist et al.</del>
	4-8	US-5474741	1995/12/12	Mikeska et al.
	4-9	US-5474819	1995/12/12	Chambers et al.
	4-10	US-5475741	1995/12/12	Davis et al.
	4-11	US-5483524	1996/01	Lev et al.
	4-12	US-5487100	1996/01	Kane
	4-13	US-5491800	1996/13/02	Goldsmith et al.
	4-14	US-5500890	1996/03	Rogge et al.
	4-15	US-5509058	1996/16/04	Sestak et al.
	4-16	US-5517432	1996/05	Chandra et al.
	4-17	US-5524141	1996/04/06	Braun et al.
	4-18	US-5528671	1996/18/06	Ryu et al.
	4-19	US-5533102	1996/02/07	Robinson et al.
	4-20	US-5544164	1996/08	Baran
	4-21	US-5544322	1996/06/08	Cheng et al.
	4-22	US-5546448	1996/08	Caswell et al.
	4-23	US-5546452	1996/13/08	Andrews et al.
	4-24	US-5548636	1996/08	Bannister et al.

Examiner Signature		Date Considered	
--------------------	--	-----------------	--

\*Examiner: Initial if reference was considered, whether or not citation is in conformance with MPEP 609. Draw a line through citation if not in conformance and not considered. Include a copy of this form with next communication to applicant.

<b>INFORMATION DISCLOSURE STATEMENT BY APPLICANT</b> FORM PTO-1449 (modified)	Reexam number	90/010,416
	First Named Inventor	Hutton
	Patent Under Re-Exam	6108704
	Issue Date	2000/08/22
	Group Art Unit	3992
	Examiner Name	KOSOWSKI, ALEXANDER J
	Attorney Docket No.	2655-0188
	Confirmation No.	1061
Sheet 5 of 30		

U.S. PATENT DOCUMENTS				
Examiner Initials*	Cite No.	Document No.	Publication/ Issue Date	Name of Patentee or Applicant of Cited Document
	5-1	US-5548694	1996/08	Frisken Gibson
	5-2	US-5563882	1996/10	Bruno et al.
	5-3	US-5572643	1996/11	Judson, David H.
	5-4	US-5574774	1996/11	Ahlberg et al.
	5-5	US-5574934	1996/12/11	Mirashrafi et al.
	5-6	US-5581522	1996/12/03	Shibuya et al.
	5-7	US-5581702	1996/12	McArdle et al.
	5-8	US-5586257	1996/17/12	Perlman
	5-9	US-5586260	1996/17/12	Hu
	5-10	US-5591800	1996/02	Goldsmith et al.
	5-11	US-5604737	1997/02	Iwami et al.
	5-12	US-5606669	1997/25/02	Bertin et al.
	5-13	US-5614940	1997/25/03	Cobbley et al.
	5-14	US-5619557	1997/08/04	Van Berkum
	5-15	US-5623483	1997/22/04	Agrawal et al.
	5-16	US-5623490	1997/04	Richter et al.
	5-17	US-5623605	1997/22/04	Keshav et al.
	5-18	US-5625407	1997/29/04	Biggs et al.
	5-19	US-5636282	1997/06	Holmquist et al.
	5-20	US-5636346	1997/06	Saxe
	5-21	US-5642156	1997/24/06	Saiki
	5-22	US-5644629	1997/07	Chow
	5-23	US-5651006	1997/07	Fujino et al.
	5-24	US-5652759	1997/07	Stringfellow, Jr.

Examiner Signature		Date Considered	
--------------------	--	-----------------	--

\*Examiner: Initial if reference was considered, whether or not citation is in conformance with MPEP 609. Draw a line through citation if not in conformance and not considered. Include a copy of this form with next communication to applicant.

<b>INFORMATION DISCLOSURE STATEMENT BY APPLICANT</b> FORM PTO-1449 (modified)	Reexam number	90/010,416
	First Named Inventor	Hutton
	Patent Under Re-Exam	6108704
	Issue Date	2000/08/22
	Group Art Unit	3992
	Examiner Name	KOSOWSKI, ALEXANDER J
	Attorney Docket No.	2655-0188
	Confirmation No.	1061

Sheet 6 of 30

U.S. PATENT DOCUMENTS				
Examiner Initials*	Cite No.	Document No.	Publication/ Issue Date	Name of Patentee or Applicant of Cited Document
	6-1	US-5655120	1997/08	Witte et al.
	6-2	US-5659542	1997/08	Bell et al.
	6-3	US-5659596	1997/19/08	Dunn
	6-4	US-5668862	1997/09	Bannister et al.
	6-5	US-5671428	1997/23/09	Muranaga et al.
	6-6	US-5675507	1997/10	Bobo
	<del>6-7</del>	<del>US-5680392</del>	<del>1997/10</del>	<del>Semaan</del>
	6-8	US-5684800	1997/11	Dobbins et al.
	6-9	US-5689553	1997/18/11	Ahuja et al.
	6-10	US-5692192	1997/11	Sudo
	6-11	US-5694594	1997/02/12	Chang
	6-12	US-5701463	1997/23/12	Malcolm
	6-13	US-5708422	1998/13/01	Blonder et al.
	6-14	US-5708655	1998/01	Toth et al.
	6-15	US-5710884	1998/20/01	Dedrick
	6-16	US-5717923	1998/10/02	Dedrick
	6-17	US-5719786	1998/02	Nelson et al.
	6-18	US-5721827	1998/24/02	Logan et al.
	6-19	US-5724092	1998/03/03	Davidsohn et al.
	6-20	US-5724412	1998/03	Srinivasan
	6-21	US-5724506	1998/03/03	Cleron et al.
	6-22	US-5726984	1998/10/03	Kubler et al.
	6-23	US-5729748	1998/03	Robbins et al.
	6-24	US-5732078	1998/03	Arango

Examiner Signature		Date Considered	
--------------------	--	-----------------	--

\*Examiner: Initial if reference was considered, whether or not citation is in conformance with MPEP 609. Draw a line through citation if not in conformance and not considered. Include a copy of this form with next communication to applicant

<b>INFORMATION DISCLOSURE STATEMENT BY APPLICANT</b> FORM PTO-1449 (modified)  Sheet 7 of 30	Reexam number	90/010,416
	First Named Inventor	Hutton
	Patent Under Re-Exam	6108704
	Issue Date	2000/08/22
	Group Art Unit	3992
	Examiner Name	KOSOWSKI, ALEXANDER J
	Attorney Docket No.	2655-0188
	Confirmation No.	1061

U.S. PATENT DOCUMENTS				
Examiner Initials*	Cite No.	Document No.	Publication/ Issue Date	Name of Patentee or Applicant of Cited Document
	7-1	US-5736968	1998/04	Tsakiris, Alexander L.
	7-2	US-5742668	1998/04	Pepe et al.
	7-3	US-5742675	1998/21/04	Kilander et al.
	7-4	US-5742762	1998/21/04	Scholl et al.
	7-5	US-5742905	1998/04	Pepe et al.
	7-6	US-5745642	1998/28/04	Ahn
	<del>7-7</del>	<del>US-5745702</del>	<del>1998/04</del>	<del>Morozumi</del>
	7-8	US-5745711	1998/04	Kitahara et al.
	7-9	US-5751712	1998/05	Farwell et al.
	7-10	US-5751961	1998/05	Smyk
	7-11	US-5754636	1998/05	Bayless et al.
	7-12	US-5754939	1998/19/05	Herz et al.
	7-13	US-5758110	1998/05	Boss et al.
	7-14	US-5758257	1998/26/03	Herz et al.
	7-15	US-5761606	1998/06	Wolzien
	7-16	US-5764736	1998/06	Shachar et al.
	7-17	US-5764741	1998/09/06	Barak
	7-18	US-5764756	1998/09/06	Onweller
	7-19	US-5767897	1998/16/06	Howell
	7-20	US-5768527	1998/06	Zhu et al.
	7-21	US-5771355	1998/23/06	Kuzma
	7-22	US-5774660	1998/30/06	Brendel et al.
	7-23	US-5774666	1998/30/06	Portuesi
	7-24	US-5778181	1998/07	Hidary et al.

Examiner Signature		Date Considered	
--------------------	--	-----------------	--

\*Examiner: Initial if reference was considered, whether or not citation is in conformance with MPEP 809. Draw a line through citation if not in conformance and not considered. Include a copy of this form with next communication to applicant.

<p><b>INFORMATION DISCLOSURE STATEMENT BY APPLICANT</b> FORM PTO-1449 (modified)</p> <p>Sheet 8 of 30</p>	Reexam number	90/010,416
	First Named Inventor	Hutton
	Patent Under Re-Exam	6108704
	Issue Date	2000/08/22
	Group Art Unit	3992
	Examiner Name	KOSOWSKI, ALEXANDER J
	Attorney Docket No.	2655-0188
	Confirmation No.	1061

U.S. PATENT DOCUMENTS				
Examiner Initials*	Cite No.	Document No.	Publication/ Issue Date	Name of Patentee or Applicant of Cited Document
	8-1	US-5778187	1998/07	Monteiro et al.
	8-2	US-5784564	1998/21/07	Camaisa et al.
	8-3	US-5784619	1998/21/07	Evans et al.
	8-4	US-5787253	1998/07	McCreery et al.
	8-5	US-5790548	1998/08	Sistanizadeh et al.
	8-6	US-5790792	1998/08	Dudgeon et al.
	<del>8-7</del>	<del>US-5790793</del>	<del>1998/08</del>	<del>Higley</del>
	8-8	US-5793365	1998/11/08	Tang et al.
	8-9	US-5794018	1998/08	Vrilo et al.
	8-10	US-5794257	1998/08	Liu et al.
	8-11	US-5796394	1998/08	Wicks et al.
	8-12	US-5799063	1998/08	Krane
	8-13	US-5799072	1998/08	Vulcan et al.
	8-14	US-5799150	1998/08	Hamilton et al.
	8-15	US-5805587	1998/09	Norris et al.
	8-16	US-5805810	1998/09	Maxwell
	8-17	US-5805822	1998/08/09	Long et al.
	8-18	US-5809233	1998/15/09	Shur
	8-19	US-5812819	1998/22/08	Rodwin et al.
	8-20	US-5816919	1998/10	Scagnelli et al.
	8-21	US-5818510	1998/10	Cobbley et al.
	8-22	US-5818836	1998/10	DuVal
	8-23	US-5822524	1998/10	Chen et al.
	8-24	US-5828837	1998/10	Eikeland

Examiner Signature		Date Considered	
--------------------	--	-----------------	--

\*Examiner: Initial if reference was considered, whether or not citation is in conformance with MPEP 609. Draw a line through citation if not in conformance and not considered. Include a copy of this form with next communication to applicant.

<b>INFORMATION DISCLOSURE STATEMENT BY APPLICANT</b> FORM PTO-1449 (modified)	Reexam number	90/010,416
	First Named Inventor	Hutton
	Patent Under Re-Exam	6108704
	Issue Date	2000/08/22
	Group Art Unit	3992
	Examiner Name	KOSOWSKI, ALEXANDER J
	Attorney Docket No.	2655-0188
	Confirmation No.	1061

Sheet 9 of 30

U.S. PATENT DOCUMENTS				
Examiner Initials*	Cite No.	Document No.	Publication/ Issue Date	Name of Patentee or Applicant of Cited Document
	9-1	US-5828843	1998/27/10	Grimm et al.
	9-2	US-5828846	1998/10	Kirby et al.
	9-3	US-5832119	1998/11	Rhoads
	9-4	US-5832240	1998/11	Larsen et al.
	9-5	US-5835720	1998/10/11	Nelson et al.
	9-6	US-5835723	1998/11	Andrews et al.
	9-7	<del>US-5835725</del>	<del>1998/10/11</del>	<del>Chiang et al.</del>
	9-8	US-5838683	1998/11	Corley et al.
	9-9	US-5838970	1998/17/11	Thomas
	9-10	US-5841769	1998/11	Okanoue et al.
	9-11	US-5842216	1998/11	Anderson et al.
	9-12	US-5848143	1998/08/12	Andrews et al.
	9-13	US-5848396	1998/12	Gerace
	9-14	US-5854901	1998/12	Cole et al.
	9-15	US-5857072	1999/01	Crowle
	9-16	US-5864684	1999/26/01	Nielsen
	9-17	US-5867156	1999/02	Beard et al.
	9-18	US-5867654	1999/02/02	Ludwig et al.
	9-19	US-5867665	1999/02/02	Butman et al.
	9-20	US-5872850	1999/16/02	Klein et al.
	9-21	US-5872922	1999/02	Hogan et al.
	9-22	US-5872972	1999/02	Boland et al.
	9-23	US-5884032	1999/03	Bateman et al.
	9-24	US-5884035	1999/16/03	Butman et al.

Examiner Signature		Date Considered	
--------------------	--	-----------------	--

\*Examiner: Initial if reference was considered, whether or not citation is in conformance with MPEP 609. Draw a line through citation if not in conformance and not considered. Include a copy of this form with next communication to applicant.

<b>INFORMATION DISCLOSURE STATEMENT BY APPLICANT</b> FORM PTO-1449 (modified)	Reexam number	90/010,416
	First Named Inventor	Hutton
	Patent Under Re-Exam	6108704
	Issue Date	2000/08/22
	Group Art Unit	3992
	Examiner Name	KOSOWSKI, ALEXANDER J
	Attorney Docket No.	2655-0188
	Confirmation No.	1061

Sheet 10 of 30

U.S. PATENT DOCUMENTS				
Examiner Initials*	Cite No.	Document No.	Publication/ Issue Date	Name of Patentee or Applicant of Cited Document
	10-1	US-5884077	1999/03	Suzuki
	10-2	US-5890162	1999/03	Huckins
	10-3	US-5892825	1999/06/04	Mages et al.
	10-4	US-5892903	1999/06/04	Klaus
	10-5	US-5892924	1999/04	Lyon et al.
	10-6	US-5903721	1999/11/05	Sixtus
	<del>10-7</del>	<del>US-5903723</del>	<del>1999/11/05</del>	<del>Beck et al.</del>
	10-8	US-5903727	1999/11/05	Nielsen
	10-9	US-5905719	1999/05	Arnold et al.
	10-10	US-5905736	1999/18/05	Ronen et al.
	10-11	US-5905865	1999/05	Palmer et al.
	10-12	US-5905872	1999/05	DeSimone et al.
	10-13	US-5915001	1999/06	Uppaluru
	10-14	US-5923736	1999/07	Shachar, Yuval
	10-15	US-5924093	1999/07	Potter et al.
	10-16	US-5925103	1999/10/07	Magallanes et al.
	10-17	US-5928327	1999/07	Wang et al.
	10-18	US-5929849	1999/07	Kikinis
	10-19	US-5937162	1999/08	Funk et al.
	10-20	US-5946386	1999/08	Rogers et al.
	10-21	US-5946629	1999/08	Sawyer et al.
	10-22	US-5950123	1999/09	Schweib et al.
	10-23	US-5950172	1999/09	Klingman
	10-24	US-5956482	1999/09	Agraharam et al.

Examiner Signature		Date Considered	
--------------------	--	-----------------	--

\*Examiner. Initial if reference was considered, whether or not citation is in conformance with MPEP 609. Draw a line through citation if not in conformance and not considered. Include a copy of this form with next communication to applicant.

<b>INFORMATION DISCLOSURE STATEMENT BY APPLICANT</b> FORM PTO-1449 (modified)	Reexam number	90/010,416
	First Named Inventor	Hutton
	Patent Under Re-Exam	6108704
	Issue Date	2000/08/22
	Group Art Unit	3992
	Examiner Name	KOSOWSKI, ALEXANDER J
	Attorney Docket No.	2655-0188
	Confirmation No.	1061

Sheet 11 of 30

U.S. PATENT DOCUMENTS				
Examiner Initials*	Cite No.	Document No.	Publication/ Issue Date	Name of Patentee or Applicant of Cited Document
	11-1	US-5961584	1999/10	Wolf
	11-2	US-5964872	1999/12/10	Turpin
	11-3	US-5969967	1999/10	Aahlad et al.
	11-4	US-5982774	1999/11	Foladare et al
	11-5	US-5983005	1999/11	Monteiro et al.
	11-6	US-5999965	1999/07/12	Kelly
	<del>11-7</del>	<del>US-6005870</del>	<del>1999/21/12</del>	<del>Leung</del>
	11-8	US-6006257	1999/12	Slezak
	11-9	US-6014379	2000/01	White et al.
	11-10	US-6014710	2000/01	Talluri et al.
	11-11	US-6016393	2000/18/01	White et al.
	11-12	US-6018768	2000/01	Ullman et al.
	11-13	US-6018771	2000/25/01	Hayden
	11-14	US-6021126	2000/02	White et al.
	11-15	US-6026086	2000/02	Lancelot et al.
	11-16	US-6026425	2000/02	Suguri et al.
	11-17	US-6029175	2000/22/02	Chow et al.
	11-18	US-6032192	2000/29/02	Wegner et al.
	11-19	US-6041345	2000/03	Levi et al.
	11-20	US-6047292	2000/04/04	Kelly et al.
	11-21	US-6055594	2000/04	Lo et al.
	11-22	US-6061716	2000/05	Moncreiff
	11-23	US-6064975	2000/05	Moon et al.
	11-24	US-6065048	2000/16/05	Highley

Examiner Signature		Date Considered	
--------------------	--	-----------------	--

\*Examiner: Initial if reference was considered, whether or not citation is in conformance with MPEP 609. Draw a line through citation if not in conformance and not considered. Include a copy of this form with next communication to applicant.



<b>INFORMATION DISCLOSURE STATEMENT BY APPLICANT</b> FORM PTO-1449 (modified)	Reexam number	90/010,416
	First Named Inventor	Hutton
	Patent Under Re-Exam	6108704
	Issue Date	2000/08/22
	Group Art Unit	3992
	Examiner Name	KOSOWSKI, ALEXANDER J
	Attorney Docket No.	2655-0188
	Confirmation No.	1061

Sheet 12 of 30

U.S. PATENT DOCUMENTS				
Examiner Initials*	Cite No.	Document No.	Publication/ Issue Date	Name of Patentee or Applicant of Cited Document
	12-1	US-6069890	2000/30/05	White et al.
	12-2	US-6085217	2000/07	Ault et al.
	12-3	US-6101182	2000/08	Sistanizadeh et al.
	12-4	US-6105053	2000/08	Kimmel et al.
	12-5	US-6122255	2000/09	Bartholomew et al.
	12-6	US-6125113	2000/09	Farris et al.
	<del>12-7</del>	<del>US-6137877</del>	<del>2000/24/10</del>	<del>Robin et al.</del>
	12-8	US-6141341	2000/31/10	Jones et al.
	12-9	US-6151643	2000/11	Cheng et al.
	12-10	US-6154445	2000/11	Farris et al.
	12-11	US-6163316	2000/12	Killian
	12-12	US-6173044	2001/01	Hortensius et al.
	12-13	US-6178453	2001/23/01	Mattaway et al.
	12-14	US-6181689	2001/01	Choung et al.
	12-15	US-6185184	2001/06/02	Mattaway et al.
	12-16	US-6188677	2001/02	Oyama et al.
	12-17	US-6195357	2001/02	Polcyn
	12-18	US-6198303	2001/03	Rangasayee
	12-19	US-6205135	2001/20/03	Chinni et al.
	12-20	US-6212625	2001/04	Russell
	12-21	US-6226678	2001/05	Mattaway et al.
	12-22	US-6226690	2001/05	Banda et al.
	12-23	US-6240444	2001/05	Fin et al.
	12-24	US-6243373	2001/06	Turock

Examiner Signature		Date Considered	
--------------------	--	-----------------	--

\*Examiner: Initial if reference was considered, whether or not citation is in conformance with MPEP 609. Draw a line through citation if not in conformance and not considered. Include a copy of this form with next communication to applicant.

<p><b>INFORMATION DISCLOSURE STATEMENT BY APPLICANT</b> FORM PTO-1449 (modified)</p> <p>Sheet 13 of 30</p>	Reexam number	90/010,416
	First Named Inventor	Hutton
	Patent Under Re-Exam	6108704
	Issue Date	2000/08/22
	Group Art Unit	3992
	Examiner Name	KOSOWSKI, ALEXANDER J
	Attorney Docket No.	2655-0188
	Confirmation No.	1061

**U.S. PATENT DOCUMENTS**

Examiner Initials*	Cite No.	Document No.	Publication/ Issue Date	Name of Patentee or Applicant of Cited Document
	13-1	US-6266539	2001/07	Pardo
	13-2	US-6275490	2001/14/08	Mattaway et al.
	13-3	US-6282272	2001/08	Noonen et al.
	13-4	US-6289369	2001/11/09	Sundaresan
	13-5	US-6300863	2001/10	Cotichini et al.
	13-6	US-6338078	2002/01	Chang et al.
	13-7	US-6343115	2002/01	Foladare et al.
	13-8	US-6343220	2002/29/01	Van Der Salm
	13-9	US-6347085	2002/02	Kelly
	13-10	US-6347342	2002/02	Marcos et al.
	13-11	US-6377568	2002/04	Kelly
	13-12	US-6385583	2002/05	Ladd et al.
	13-13	US-6393455	2002/05	Eilert et al.
	13-14	US-6427064	2002/07	Henderson, Daniel
	13-15	US-6434552	2002/08	Leong, Jin Fye
	13-16	US-6463565	2002/08/10	Keith C. Kelly
	13-17	US-6477586	2002/11	Achenson et al.
	13-18	US-6594254	2003/15/07	Kelly
	13-19	US-6687738	2004/03/02	Glenn W. Hutton
	13-20	US-6704802	2004/03	Finch et al.
	13-21	US-6728784	2004/27/04	Mattaway
	13-22	US-6772335	2004/08	Curtis et al.
	13-23	US-6829645	2004/07/12	Glenn W. Hutton
	13-24	US-6888836	2005/03/05	Cherkasova

Examiner Signature		Date Considered	
--------------------	--	-----------------	--

\*Examiner: Initial if reference was considered, whether or not citation is in conformance with MPEP 609. Draw a line through citation if not in conformance and not considered. Include a copy of this form with next communication to applicant.

<b>INFORMATION DISCLOSURE STATEMENT BY APPLICANT</b> FORM PTO-1449 (modified)  Sheet 14 of 30	Reexam number	90/010,416
	First Named Inventor	Hutton
	Patent Under Re-Exam	6108704
	Issue Date	2000/08/22
	Group Art Unit	3992
	Examiner Name	KOSOWSKI, ALEXANDER J
	Attorney Docket No.	2655-0188
	Confirmation No.	1061

U.S. PATENT DOCUMENTS				
Examiner Initials*	Cite No.	Document No.	Publication/ Issue Date	Name of Patentee or Applicant of Cited Document
	14-1	US-6909708	2005/06	Krishnaswamy et al.
	14-2			
	14-3			
	14-4			
	14-5			
	14-6			
	14-7			
	14-8			
	14-9			
	14-10			
	14-11			
	14-12			
	14-13			
	14-14			
	14-15			
	14-16			
	14-17			
	14-18			
	14-19			
	14-20			
	14-21			
	14-22			
	14-23			
	14-24			

Examiner Signature		Date Considered	
--------------------	--	-----------------	--

\*Examiner: Initial if reference was considered, whether or not citation is in conformance with MPEP 609. Draw a line through citation if not in conformance and not considered. Include a copy of this form with next communication to applicant.

<b>INFORMATION DISCLOSURE STATEMENT BY APPLICANT</b> FORM PTO-1449 (modified)	Reexam number	90/010,416
	First Named Inventor	Hutton
	Patent Under Re-Exam	6108704
	Issue Date	2000/08/22
	Group Art Unit	3992
	Examiner Name	KOSOWSKI, ALEXANDER J
	Attorney Docket No.	2655-0188
Sheet 15 of 30	Confirmation No.	1061

FOREIGN PATENT DOCUMENTS					
Examiner Initials*	Cite No.	Document No.	Publication Date	Name of Patentee or Applicant of Cited Document	Notes
	15-1	AU-200059377-A1	11-23-2000	Glenn W. Hutton et al.	
	15-2	AU-200059378-A1	11-30-2000	Glenn W. Hutton et al.	
	15-3	AU-200059379-A1	11-23-2000	Glenn W. Hutton et al.	
	15-4	EP-0518596	12/16/1992	Digital Equipment Corp	
	15-5	EP-0559047	09-1993	Iglehart	
	15-6	EP-0597691	05/18/1994	IBM	
	15-7	EP-0632672	01/04/1995	IBM	
	15-8	EP-0648038	04/12/1995	IBM	
	15-9	EP-1379039-A2	01-07-2004	Glenn W. Hutton	
	15-10	EP-1379050-A2	01-07-2004	Glenn W. Hutton	
	15-11	GB-2283645	05/10/1995	Digital Equipment Int.	
	15-12	JP 63-131637	3/6/1988	Y. Takehiko (w/ English abstract)	T
	15-13	JP 6-62020 (w/ SOR and EA)	1994/03/04	Masatoshi et al.	
	15-14	JP-5944140	03-12-1984	Junichi Kimura et al.	T
	15-15	WO-9422087	09/29/1994	3Com Corp	
	15-16	WO-9714234	04-17-1997	Glenn W. Hutton	
	15-17	WO-9811704	03/19/1998	Don Joon Lee et al.	
	15-18				
	15-19				
	15-20				
	15-21				
	15-22				
	15-23				
	15-24				

Examiner Signature		Date Considered	
--------------------	--	-----------------	--

\*Examiner: Initial if reference was considered, whether or not citation is in conformance with MPEP 609. Draw a line through citation if not in conformance and not considered. Include a copy of this form with next communication to applicant. Notes: If identified, the following is provided: EA = English Abstract. T = Translation. PF = Patent Family.

<b>INFORMATION DISCLOSURE STATEMENT BY APPLICANT</b> FORM PTO-1449 (modified)	Reexam number	90/010,416
	First Named Inventor	Hutton
	Patent Under Re-Exam	6108704
	Issue Date	2000/08/22
	Group Art Unit	3992
	Examiner Name	KOSOWSKI, ALEXANDER J
	Attorney Docket No.	2655-0188
	Confirmation No.	1061
Sheet 16 of 30		

NON-PATENT REFERENCES			
Examiner Initials*	Cite No.	Non-patent Reference bibliographic information, where available	Notes
	16-1	"Circuit Switching", Ericsson, last published July 5, 2001, found at <a href="http://www.ericsson.com/multiservicenetworks/circuitswitching/axe/">http://www.ericsson.com/multiservicenetworks/circuitswitching/axe/</a> printed on August 1, 2001, 2 pages.	
	16-2	"Data Communication Over the Telephone Network", International Telecommunication Union, CCITT The International Telegraph and Telephone Consultative Committee, Blue Book, Volume VIII - Fascicle VIII.1, IXth Plenary Assembly, Melbourne, November 14-25, 1988, pages 296-370	
	16-3	"Full Duplex Speakerphone", IBM Technical Disclosure Bulletin, Vol. 29, No. 12, May 1987, pages 5599-5602	
	16-4	"ICL OPD - One Per Desk", Issue 01 August 1990, A Comprehensive Technical Information Document (24 pages)	
	16-5	"Information Processing Techniques Program, Volume II, Wideband Integrated Voice/Data Technology" Semiannual Technical Summary Report, Massachusetts Institute of Technology Lexington, MA, 1 October 1977 - 31 March 1978, Issued 31 August 1978, pages 1-25 and 27-31, ADA067014	
	16-6	"Integrated Voice/Data PABX Communications", IBM Technical Disclosure Bulletin, September 1986, <a href="http://patents.ibm.com">http://patents.ibm.com</a>	
	16-7	"Level 1-5 of 65 Stories" 1990 Network World, Inc., April 16, 1990, pages 114-115	

Examiner Signature		Date Considered	
--------------------	--	-----------------	--

\*Examiner. Initial if reference was considered, whether or not citation is in conformance with MPEP 609. Draw a line through citation if not in conformance and not considered. Include a copy of this form with next communication to applicant. Notes: If identified, the following is provided: EA = English Abstract, T = Translation, PF = Patent Family.

<b>INFORMATION DISCLOSURE STATEMENT BY APPLICANT</b> FORM PTO-1449 (modified)  Sheet 17 of 30	Reexam number	90/010,416
	First Named Inventor	Hutton
	Patent Under Re-Exam	6108704
	Issue Date	2000/08/22
	Group Art Unit	3992
	Examiner Name	KOSOWSKI, ALEXANDER J
	Attorney Docket No.	2655-0188
	Confirmation No.	1061

NON-PATENT REFERENCES			
Examiner Initials*	Cite No.	Non-patent Reference bibliographic information, where available	Notes
	17-1	"Multi-Service Networks", Ericsson, last published June 27, 2001, found at <a href="http://www.ericsson.com/multiservicenetworks/circuitswitching/">http://www.ericsson.com/multiservicenetworks/circuitswitching/</a> printed on August 1, 2001, 2 pages.	
	17-2	"The History of TPC.INT", January 15, 1999, 2 pages, found at <a href="http://www.tpc.int/faq/history.html">http://www.tpc.int/faq/history.html</a> printed on August 8, 2002.	
	17-3	A. A. Kapauan, et al. "Wideband Packet Access for Workstations: Integrated Voice/Data/Image Services on the UNIX+ PC", IEEE Global Telecommunications Conference, Houston, Texas, December 1-4, 1986, Conference Record Vol. 3, pages 1439-1441	
	17-4	AHRENS, Richard L., "Frequently-Asked Questions about Internet VoiceChat 1.1 FAQ Version: 1.0", 1994, 6 pages.	
	17-5	Andy Hopper "Pandora - An Experimental System for Multimedia Applications", Operating Systems Review, January 12, 1990, pages 1-16	
	17-6	BENNETT, Geoff, "Designing TCP/IP Internetworks", Chapter 11, pages 290, 291 and 323, Van Nostrand Reinhold, 1995.	
	17-7	Bernard Gold "Digital Speech Networks", Proceedings of the IEEE, Vol. 65, No. 12, December 1977, pages 1636-1658	

Examiner Signature		Date Considered	
--------------------	--	-----------------	--

\*Examiner: Initial if reference was considered, whether or not citation is in conformance with MPEP 609. Draw a line through citation if not in conformance and not considered. Include a copy of this form with next communication to applicant. Notes: If identified, the following is provided: EA = English Abstract, T = Translation, PF = Patent Family.

<b>INFORMATION DISCLOSURE STATEMENT BY APPLICANT</b> FORM PTO-1449 (modified)  Sheet 18 of 30	Reexam number	90/010,416
	First Named Inventor	Hutton
	Patent Under Re-Exam	6108704
	Issue Date	2000/08/22
	Group Art Unit	3992
	Examiner Name	KOSOWSKI, ALEXANDER J
	Attorney Docket No.	2655-0188
	Confirmation No.	1061

NON-PATENT REFERENCES			
Examiner Initials*	Cite No.	Non-patent Reference bibliographic information, where available	Notes
	18-1	Bill Newman "An ISDN Data and Voice Terminal Based on a Personal Computer", Globecom'85, IEEE Global Telecommunications Conference, Conference Record Volume 3, New Orleans, Louisiana, December 2-5, 1985, pages 1048-1052	
	18-2	BORLAND, John, "Technology uses one number to find you on any device", May 17, 2001, 3 pages, found at <a href="http://news.cnet.com/news/0-1004-201-5939191-0.html">http://news.cnet.com/news/0-1004-201-5939191-0.html</a> .	
	18-3	C. MALAMUD et al., "Principles of Operation for the TPC.INT Subdomain: General Principles and Policy", RFC 1530, October 1993, pages 1-7.	
	18-4	C. MALAMUD et al., "Principles of Operation for the TPC.INT Subdomain: Remote Printing – Administrative Policies", RFC 1529, October 1993, pages 1-5.	
	18-5	C. MALAMUD et al., "Principles of Operation for the TPC.INT Subdomain: Remote Printing – Technical Procedures", RFC 1528, October 1993, pages 1-12.	
	18-6	C. Topolcic "Experimental Internet Stream Protocol, Version 2 (ST-II)", Request for Comments 1190, October 1990, pages 1-148	
	18-7	C. YANG, "INETPhone: Telephone Services and Servers on Internet", Request for Comments 1789, pp. 1-6, April 1995.	

Examiner Signature		Date Considered	
--------------------	--	-----------------	--

\*Examiner: Initial if reference was considered, whether or not citation is in conformance with MPEP 609. Draw a line through citation if not in conformance and not considered. Include a copy of this form with next communication to applicant. Notes: If identified, the following is provided: EA = English Abstract, T = Translation, PF = Patent Family.

<b>INFORMATION DISCLOSURE STATEMENT BY APPLICANT</b> FORM PTO-1449 (modified)  Sheet 19 of 30	Reexam number	90/010,416
	First Named Inventor	Hutton
	Patent Under Re-Exam	6108704
	Issue Date	2000/08/22
	Group Art Unit	3992
	Examiner Name	KOSOWSKI, ALEXANDER J
	Attorney Docket No.	2655-0188
	Confirmation No.	1061

NON-PATENT REFERENCES			
Examiner Initials*	Cite No.	Non-patent Reference bibliographic information, where available	Notes
	19-1	Carl A. Sunshine, et al. "Broad-Band Personal Computer LAN's", IEEE Journal on Selected Areas in Communications, Vol. SAC-3, No.3, May 1985, pages 408-415	
	19-2	Cindy MUELLER et al., "ATD Data Services", <a href="http://www.iita.ucar.edu/ws/dataaworkshop/Abstract-ATD.html">http://www.iita.ucar.edu/ws/dataaworkshop/Abstract-ATD.html</a> , January 5, 1995, 2 pages.	
	19-3	Clifford J. Weinstein, et al. "Experience with Speech Communication in Packet Networks" IEEE Journal on Selected Areas in Communications, Vol. SAC-1, No. 6, (ISSN 0733-8716), December 1983, pages 963-980	
	19-4	D. Adolphs, et al. "Adapters for the Public ISDN", pages 72-80	
	19-5	D. Perkins "The Point-to-Point Protocol for the Transmission of Multi-Protocol Datagrams Over Point-to-Point Links", Request for Comments 1171, <a href="ftp://ftp.isi.edu/in-notes/rfc1171.txt">ftp://ftp.isi.edu/in-notes/rfc1171.txt</a> , July 1990, pages 1-48	
	19-6	D.C. Swinehart et al., "Adding Voice to an Office Computer Network", IEEE Global Telecommunications Conference, Nov. 28-Dec 1, 1983, Conference Record Volume 1 of 3, pages 392-398	
	19-7	Dale Gulick et al., "Interface the ISDN to Your PC With a Voice/Data Board", Design Applications, 2328 Electronic Design, 35 (1987) Dec. 10, No. 29, Hashbrouck Heights, NJ, USA, pages 85-88, XP 000004313	

Examiner Signature		Date Considered	
--------------------	--	-----------------	--

\*Examiner: Initial if reference was considered, whether or not citation is in conformance with MPEP 609. Draw a line through citation if not in conformance and not considered. Include a copy of this form with next communication to applicant. Notes: If identified, the following is provided: EA = English Abstract, T = Translation, PF = Patent Family.



<b>INFORMATION DISCLOSURE STATEMENT BY APPLICANT</b> FORM PTO-1449 (modified)	Reexam number	90/010,416
	First Named Inventor	Hutton
	Patent Under Re-Exam	6108704
	Issue Date	2000/08/22
	Group Art Unit	3992
	Examiner Name	KOSOWSKI, ALEXANDER J
	Attorney Docket No.	2655-0188
	Confirmation No.	1061
Sheet 20 of 30		

NON-PATENT REFERENCES			
Examiner Initials*	Cite No.	Non-patent Reference bibliographic information, where available	Notes
	20-1	Daniel C. Swinehart "Telephone Management in the Etherphone System", IEEE/IEICE Global Telecommunications Conference '87, Conference Record Volume 2 of 3, November 15-18, 1987, pages 1176-1180	
	20-2	Danny Cohen "A Network Voice Protocol NVP-II", April 1, 1981, pages 1-68	
	20-3	Danny Cohen "Packet Communication of Online Speech", AFIPS Conference Proceedings, 1981 National Computer Conference, May 4-7, 1981, Chicago, Illinois, pages 169-176	
	20-4	Danny Cohen "Specifications for the Network Voice Protocol (NVP)", Request for Comments 741, January 29, 1976, pages 1-30	
	20-5	Don H. Johnson, et al. "A Local Access Network for Packetized Digital Voice Communication", IEEE Transactions on Communications, Vol. Com. 29, No. 5, May 1981, pages 679-688	
	20-6	Douglas B. Terry and Daniel C. Swinehart, "Managing Stored Voice in the Etherphone System", 1987 ACM 089791-242-X/87/0011/0103, pages 103-104	
	20-7	Douglas B. Terry and Daniel C. Swinehart, "Managing Stored Voice in the Etherphone System", ACM Transactions on Computer Systems, Vol. 6, No. 1, February 1988, pages 3-27	

Examiner Signature		Date Considered	
--------------------	--	-----------------	--

\*Examiner: Initial if reference was considered, whether or not citation is in conformance with MPEP 609. Draw a line through citation if not in conformance and not considered. Include a copy of this form with next communication to applicant. Notes: If identified, the following is provided: EA = English Abstract, T = Translation, PF = Patent Family.

<b>INFORMATION DISCLOSURE STATEMENT BY APPLICANT</b> FORM PTO-1449 (modified)  Sheet 21 of 30	Reexam number	90/010,416
	First Named Inventor	Hutton
	Patent Under Re-Exam	6108704
	Issue Date	2000/08/22
	Group Art Unit	3992
	Examiner Name	KOSOWSKI, ALEXANDER J
	Attorney Docket No.	2655-0188
	Confirmation No.	1061

NON-PATENT REFERENCES			
Examiner Initials*	Cite No.	Non-patent Reference bibliographic information, where available	Notes
	21-1	Eve M. Schooler, et al. "A Packet-Switched Multimedia Conferencing System", SIGOIS Bulletin, pages 12-22	
	21-2	Gary C. Kessler "ISDN Concepts, Facilities, and Services", McGraw-Hill, Inc., c1990, pages 224-231, ISBN 0-07-034242-3	
	21-3	Giulio Barberis, et al. "Coded Speech in Packet-Switched Networks: Models and Experiments" IEEE Journal on Selected Areas in Communications, Vol. SAC-1, No. 6, December 1983, pages 1028-1038	
	21-4	H. Jonathan Chao, et al. "A Packet Video System Using the Dynamic Time Division Multiplexing Technique", IEEE Global Telecommunications Conference, Houston, Texas, December 1-4, 1988, Conference Record, Vol. 3, pages 0767-0772	
	21-5	H. Opderbeck "Throughput Degredations for Single Packet Messages", Request for Comments 632, ftp://ftp.isi.edu/in-notes/rfc632.txt, May 20, 1974, pages 1-6	
	21-6	Henning Schulzrinne "Voice Communication Across the Internet: A Network Voice Terminal", July 29, 1992, pages 1-34	
	21-7	Hiroshi Kobayashi and Hideaki Haruyama, "Voice, Data and Video Integrated Broadband Metropolitan Area Network", Electronics and Communications in Japan, Part 1, Vol. 73, No. 11, 1990, pages 34-42	

Examiner Signature		Date Considered	
--------------------	--	-----------------	--

\*Examiner: Initial if reference was considered, whether or not citation is in conformance with MPEP 609. Draw a line through citation if not in conformance and not considered. Include a copy of this form with next communication to applicant. Notes: If identified, the following is provided: EA = English Abstract, T = Translation, PF = Patent Family.

<b>INFORMATION DISCLOSURE STATEMENT BY APPLICANT</b> FORM PTO-1449 (modified)  Sheet 22 of 30	Reexam number	90/010,416
	First Named Inventor	Hutton
	Patent Under Re-Exam	6108704
	Issue Date	2000/08/22
	Group Art Unit	3992
	Examiner Name	KOSOWSKI, ALEXANDER J
	Attorney Docket No.	2655-0188
	Confirmation No.	1061

**NON-PATENT REFERENCES**

Examiner Initials*	Cite No.	Non-patent Reference bibliographic information, where available	Notes
	22-1	Hiroyuki Ichikawa et al. "High-Speed Packet Switching Systems for Multimedia Communications", IEEE Journal on Selected Areas in Communications, October 1987, Volume SAC-5, Number 8 (ISSN 0733-8716), pages 1336-1345	
	22-2	Ian H. Merritt "Providing Telephone Line Access to a Packet Voice Network", University of Southern California, Marina Del Rey. Information Sciences Inst., February 1983, ADA126270	
	22-3	Implementation of Next-Generation Agent-Dedicated Communications, by Agatsuma et al., Tech Report of IEICE 94-218 (March 1995)	
	22-4	International Preliminary Examination Report (IPER) issued March 26, 1998 in corresponding International Application Serial No. PCT/US96/15504	
	22-5	International Search Report issued January 27, 1998 in corresponding International Application Serial No. PCT/US96/15504.	
	22-6	Israel GITMAN, et al. "Economic Analysis of Integrated Voice and Data Networks: A Case Study" Proceedings of the IEEE, Vol. 66, No. 11, November 1978, pages 1549-1570	
	22-7	J. Huelamo, et al. "End User Premises Equipment and Terminals for Broadband Applications", Electrical Communication, Volume 64, Number 2/3, 1990	

Examiner Signature		Date Considered	
--------------------	--	-----------------	--

\*Examiner: Initial if reference was considered, whether or not citation is in conformance with MPEP 609. Draw a line through citation if not in conformance and not considered. Include a copy of this form with next communication to applicant. Notes: If identified, the following is provided: EA = English Abstract, T = Translation, PF = Patent Family.

<b>INFORMATION DISCLOSURE STATEMENT BY APPLICANT</b> FORM PTO-1449 (modified)	Reexam number	90/010,416
	First Named Inventor	Hutton
	Patent Under Re-Exam	6108704
	Issue Date	2000/08/22
	Group Art Unit	3992
	Examiner Name	KOSOWSKI, ALEXANDER J
	Attorney Docket No.	2655-0188
Sheet 23 of 30	Confirmation No.	1061

NON-PATENT REFERENCES			
Examiner Initials*	Cite No.	Non-patent Reference bibliographic information, where available	Notes
	23-1	J. K. Reynolds et al., "Voice File Interchange Protocol (VFIP), Request for Comments 978, ftp://ftp.isi.edu/innotes/rfc978.txt, February 1986, pages 1-5	
	23-2	J. Romkey "A Nonstandard For Transmission of IP Datagrams Over Serial Lines: Slip", Request for Comments 1055, ftp://ftp.isi.edu/in-notes/std/std47.txt, June 1988, pages 1-6	
	23-3	James D. Mills, et al. "A data and voice system for the general service telephone network", Proceedings IECON '87, 1987 International Conference on IND. Electronics, Control, and Instrumentation, Cambridge, Massachusetts, November 3-6, 1987	
	23-4	James W. Forgie "Speech Transmission in Packet-Switched Store-and-Forward Networks", AFIPS Conference Proceedings, 1975 National Computer Conference, May 19-22, 1975, Anaheim, California, pages 137-142	
	23-5	James W. Forgie "Voice Conferencing in Packet Networks", ICC '80, Conference Record, International Conference on Communications, Seattle, WA, June 8-12, 1980, Volume 1, 80CH1505-6 CSCB, pages 21.3.1-21.3.4	
	23-6	Jane's Military Communications 1979-80, pages 452 and 453	
	23-7	Jane's Military Communications 1985, pages 585, 546, and 545	

Examiner Signature		Date Considered	
--------------------	--	-----------------	--

\*Examiner: Initial if reference was considered, whether or not citation is in conformance with MPEP 609. Draw a line through citation if not in conformance and not considered. Include a copy of this form with next communication to applicant. Notes: If identified, the following is provided: EA = English Abstract, T = Translation, PF = Patent Family.

<b>INFORMATION DISCLOSURE STATEMENT BY APPLICANT</b> FORM PTO-1449 (modified)	Reexam number	90/010,416
	First Named Inventor	Hutton
	Patent Under Re-Exam	6108704
	Issue Date	2000/08/22
	Group Art Unit	3992
	Examiner Name	KOSOWSKI, ALEXANDER J
	Attorney Docket No.	2655-0188
Confirmation No.	1061	
Sheet 24 of 30		

NON-PATENT REFERENCES			
Examiner Initials*	Cite No.	Non-patent Reference bibliographic information, where available	Notes
	24-1	Jane's Military Communications 1989, Tenth Edition, Edited by John Williamson, ISBN 0710608772, pages 443, 507, and 512	
	24-2	Jane's Military Communications 1990-91, Eleventh Edition, Edited by John Williamson, ISBN 0710609000, pages (30), 264, 357, 398, 406, 450, 454, 456, 560, 572, 573, 814, 815, and 816	
	24-3	Jane's Military Communications 1992-93, Thirteenth Edition, Edited by John Williamson, ISBN 0710609809, pages 375, 376, 384, and 704	
	24-4	Jim Stevens, "Much More Idle Chatter About Reference Models", <a href="http://www-mice.cs.ucl.ac.uk/multimedia/misc/tcp_ip/8709.mm.www/0041.html">http://www-mice.cs.ucl.ac.uk/multimedia/misc/tcp_ip/8709.mm.www/0041.html</a> , December 18, 1987, pages 1-9	
	24-5	John Bellamy, "Digital Telephony", c1982 John Wiley & Sons, Inc., pages 392-397 and 410-412	
	24-6	JP Appln. No. 2008-163825 Office Action (Translation)	
	24-7	K. Sohraby, et al. "ISDN Primary Rate Interface Impact on Performance of Integrated Voice and Data on CSMA/CD Networks - A Measurement and Simulation Study", Globecom '90 IEEE Global Telecommunication Conference & Exhibition, San Diego, California, December 2-5, 1990. Volume 2, pages 0912-0919	

Examiner Signature		Date Considered	
--------------------	--	-----------------	--

\*Examiner: Initial if reference was considered, whether or not citation is in conformance with MPEP 609. Draw a line through citation if not in conformance and not considered. Include a copy of this form with next communication to applicant. Notes: If identified, the following is provided: EA = English Abstract, T = Translation, PF = Patent Family.

<p><b>INFORMATION DISCLOSURE STATEMENT BY APPLICANT</b> FORM PTO-1449 (modified)</p> <p>Sheet 25 of 30</p>	Reexam number	90/010,416
	First Named Inventor	Hutton
	Patent Under Re-Exam	6108704
	Issue Date	2000/08/22
	Group Art Unit	3992
	Examiner Name	KOSOWSKI, ALEXANDER J
	Attorney Docket No.	2655-0188
Confirmation No.	1061	

NON-PATENT REFERENCES			
Examiner Initials*	Cite No.	Non-patent Reference bibliographic information, where available	Notes
	25-1	Ken Sherman "Data Communications - A User's Guide", 3rd Edition, c1981 Prentice-Hall, Inc., pages 296-307 and 404-407	
	25-2	Kevin Jeffay, et al. "Kernel Support for Live Digital Audio and Video", pages 10-21, University of North Carolina at Chapel Hill, Department of Computer Science	
	25-3	Kyuta SAITO, et al. "Voice Packet Communication System for Private Networks", Globecom '89, IEEE Global Telecommunications Conference & Exhibition, Dallas, Texas, November 27-30, 1989. Volume 3, pages 1874-1878	
	25-4	Lawrence G. Roberts "The Evolution of Packet Switching", Proceedings of the IEEE, Vol. 66, No. 11, November 1978, pages 1307-1313	
	25-5	LIN, Hwa-Chun and C.S. Raghavendra, "A Dynamic Load-Balancing Policy With a Central Job Dispatcher (LBC)," IEEE Transactions on Software Engineering, Vol. 18, No. 2, February 1992, pages 148-158.	
	25-6	M. E. Ulug, et al. "Statistical Multiplexing of Data and Encoded Voice in a Transparent Intelligent Network", Fifth Data Communications Symposium, September 27-29, 1977, Snowbird, Utah, pages 6-14 - 6-20	
	25-7	M. Gopalakrishnan, et al. "Integrating Voice and Data SALAN: An Experimental Local Area Network", Computer Communications, Vol. 9, No. 4, August 1986, pages 186-194 and page 169	

Examiner Signature		Date Considered	
--------------------	--	-----------------	--

\*Examiner: Initial if reference was considered, whether or not citation is in conformance with MPEP 609. Draw a line through citation if not in conformance and not considered. Include a copy of this form with next communication to applicant. Notes: If identified, the following is provided: EA = English Abstract, T = Translation, PF = Patent Family.

<b>INFORMATION DISCLOSURE STATEMENT BY APPLICANT</b> FORM PTO-1449 (modified)  Sheet 26 of 30	Reexam number	90/010,416
	First Named Inventor	Hutton
	Patent Under Re-Exam	6108704
	Issue Date	2000/08/22
	Group Art Unit	3992
	Examiner Name	KOSOWSKI, ALEXANDER J
	Attorney Docket No.	2655-0188
	Confirmation No.	1061

NON-PATENT REFERENCES			
Examiner Initials*	Cite No.	Non-patent Reference bibliographic information, where available	Notes
	26-1	M.J. Ross "Alternatives for Integrating Voice and Data", 1981 International Switching Symposium, ISS' 81 CIC Montreal, September 21-25, 1981	
	26-2	Natesa Janakiraman "An Overview of Recent Developments in the Designs and Applications of Customer Premises Switches", IEEE Communications Magazine, October 1985, Vol. 23, No. 10, pages 32-45	
	26-3	P. Borgnis-Desbordes, et al. "Variable-Speed Data Transmission", IBM Technical Disclosure Bulletin, Vol. 27, No. 4A, September 1984, pages 2269-2270	
	26-4	P. Venkat Rangan and Daniel C. Swinehart, "Software Architecture for Integration of Video Services in the Etherphone System", IEEE Journal on Selected Areas in Communication, Vol. 9, No. 9, December 1991, pages 1395-1404	
	26-5	Paul Francis, "Comparison of Geographical and Provider-rooted Internet Addressing," Computer Networks and ISDN Systems 27(3)437-448, 1994 (selected paper from INET 94/JENC 5)	
	26-6	Paul Gilster, "Internet Navigator", Maruzen Kabushiki-Kaisha (1st Ed.), pgs. 473-476, Feb. 28, 1995 (with translation and SOR)	
	26-7	Paul Tsuchiya, Tony Eng, "Extending the IP Internet Through Address Reuse," ACM SIGCOMM Computer Communications Review, 23(1):16-33, Jan. 1993	

Examiner Signature		Date Considered	
--------------------	--	-----------------	--

\*Examiner: Initial if reference was considered, whether or not citation is in conformance with MPEP 509. Draw a line through citation if not in conformance and not considered. Include a copy of this form with next communication to applicant. Notes: If identified, the following is provided: EA = English Abstract, T = Translation, PF = Patent Family.

<b>INFORMATION DISCLOSURE STATEMENT BY APPLICANT</b> FORM PTO-1449 (modified)	Reexam number	90/010,416
	First Named Inventor	Hutton
	Patent Under Re-Exam	6108704
	Issue Date	2000/08/22
	Group Art Unit	3992
	Examiner Name	KOSOWSKI, ALEXANDER J
	Attorney Docket No.	2655-0188
Sheet 27 of 30	Confirmation No.	1061

NON-PATENT REFERENCES			
Examiner Initials*	Cite No.	Non-patent Reference bibliographic information, where available	Notes
	27-1	Philip H. Reagan, "Is it the PBX or is it the LAN?", Datamation, The Telecom Manager Emerges, 03/1984, Volume 30 Number 3, pages 3-4, 147, 148, 150	
	27-2	Polle T. Zellweger et al., "An Overview of the Etherphone System and its Applications", 2nd IEEE Conference on Computer Workstations, March 7-10, 1988, pages 160-168	
	27-3	R. BRAUDES et al., "Requirements for Multicast Protocols", Request for Comments 1458, Network Working Group, May 1993, pp. 1-19.	
	27-4	R. W. Meba, et al. "Experiments in Wdaband Packet Technology", Digital Communications - New Directions in Switching and Networks, Proceedings of the International Seminar, Zurich, Switzerland, March 11-13, 1986, pages 135-139	
	27-5	R.P. McNamara, "Some Considerations of the Voice-Data Capabilities of Broadband Cable Networks", IEEE Digest of Papers Spring CompCon 82, February 22-25, 1982, pages 312-314	
	27-6	Randy Cole "Packet Voice: When It Makes Sense", Speech Technology, September/October 1982, pages 52-61.	
	27-7	Scott FLINN, "Coordinating Heterogeneous Time-Based Media Between Independent Applications" ACM Multimedia 95 - Electronic Proceedings November 5-9, 1995, pages 1-16.	

Examiner Signature		Date Considered	
--------------------	--	-----------------	--

\*Examiner: Initial if reference was considered, whether or not citation is in conformance with MPEP 609. Draw a line through citation if not in conformance and not considered. Include a copy of this form with next communication to applicant. Notes: If identified, the following is provided: EA = English Abstract, T = Translation, PF = Patent Family.



<b>INFORMATION DISCLOSURE STATEMENT BY APPLICANT</b> FORM PTO-1449 (modified)  Sheet 28 of 30	Reexam number	90/010,416
	First Named Inventor	Hutton
	Patent Under Re-Exam	6108704
	Issue Date	2000/08/22
	Group Art Unit	3992
	Examiner Name	KOSOWSKI, ALEXANDER J
	Attorney Docket No.	2655-0188
	Confirmation No.	1061

NON-PATENT REFERENCES			
Examiner Initials*	Cite No.	Non-patent Reference bibliographic information, where available	Notes
	28-1	Shimmi Hattori et al., "Integrated Digital Switching System with Queueing Storage Facility", IEEE Transactions on Communications, Vol. Com-30, No. 8, August 1982, pages 1900-1905, (ISSN 0090-6778)	
	28-2	Steve Oltmanns, et al. "A Voice and Communications System for the IBM PC", Speech Technology, March/April 1986, pages 94-99	
	28-3	Stuart CHESHIRE et al., "Internet Mobility 4x4", www.acm.org, 1996, pages 1-12.	
	28-4	Susan Angebrannt et al., "Integrating Audio and Telephony in a Distributed Workstation Environment", Proceedings of the Summer 1991 USENIX Conference, June 10-14, 1991, Nashville, Tennessee, pages 419-435	
	28-5	T. Kamae "Visual Terminals and User Interfaces", FGCS North-Holland, pages 257-278	
	28-6	T. Kamae "Voice/Data Integration in the INS Model System and Local Area Networks" IEEE Communications Magazine, December 1986, Vol. 24, No. 12, pages 7-15	
	28-7	T7540 Digital Telephone Codec, AT&T Microelectronics, January 1991, pages 1-62 and Data Sheet Addendum, July 1991, 4 pages	

Examiner Signature		Date Considered	
--------------------	--	-----------------	--

\*Examiner: Initial if reference was considered, whether or not citation is in conformance with MPEP 609. Draw a line through citation if not in conformance and not considered. Include a copy of this form with next communication to applicant. Notes: If identified, the following is provided: EA = English Abstract, T = Translation, PF = Patent Family.

<b>INFORMATION DISCLOSURE STATEMENT BY APPLICANT</b> FORM PTO-1449 (modified)  Sheet 29 of 30	Reexam number	90/010,416
	First Named Inventor	Hutton
	Patent Under Re-Exam	6108704
	Issue Date	2000/08/22
	Group Art Unit	3992
	Examiner Name	KOSOWSKI, ALEXANDER J
	Attorney Docket No.	2655-0188
	Confirmation No.	1061

**NON-PATENT REFERENCES**

Examiner Initials*	Cite No.	Non-patent Reference bibliographic information, where available	Notes
	29-1	Takashi Yamada, et al. "New Technologies - Multimedia High-throughput X.25 Packet Switching System", NTT Review, Vol. 1, No. 2, July 1989, pages 82-88	
	29-2	talk (software) description from Wikipedia	
	29-3	Tamohiro Kawai, Nikkei Communications, No. 202, pgs 29-30, Nikkei BP, July 17, 1995 ("Communication software appears on the Internet") (w/ SOR)	
	29-4	Theodore Bialy, et al. "Voice Communication in Integrated Digital Voice and Data Networks", IEEE Transactions on Communications, Vol. Com-28, No. 9, September 1980, pages 1478-1490	
	29-5	Toru Tsuda, et al. "An Approach to Multi-Service Subscriber Loop System Using Packetized Voice/Data Terminals" ISSLS '78, The International Symposium on Subscriber Loops and Services, March 20-24, 1978. Atlanta, Georgia, Conference Record, pages 161-165	
	29-6	Translation of Japanese Kokai H07-129488 (published May 19, 1995)	
	29-7	U.S. Reexam Control No. 90/010,421 - 2009-08-14 PTO Office Action	

Examiner Signature		Date Considered	
--------------------	--	-----------------	--

\*Examiner: Initial if reference was considered, whether or not citation is in conformance with MPEP 609. Draw a line through citation if not in conformance and not considered. Include a copy of this form with next communication to applicant. Notes: If identified, the following is provided: EA = English Abstract, T = Translation, PF = Patent Family.

<b>INFORMATION DISCLOSURE STATEMENT BY APPLICANT</b> FORM PTO-1449 (modified)  Sheet 30 of 30	Reexam number	90/010,416
	First Named Inventor	Hutton
	Patent Under Re-Exam	6108704
	Issue Date	2000/08/22
	Group Art Unit	3992
	Examiner Name	KOSOWSKI, ALEXANDER J
	Attorney Docket No.	2655-0188
	Confirmation No.	1061

**NON-PATENT REFERENCES**

Examiner Initials*	Cite No.	Non-patent Reference bibliographic information, where available	Notes
	30-1	U.S. Reexam Control No. 90/010,422 - 2009-08-25 PTO Office Action	
	30-2	U.S. Reexam Control No. 90/010,424 - 2009-08-25 PTO Office Action	
	30-3	V. Jacobson, et al. "TCP Extension for High-Speed Paths", Request for Comments 1185, ftp://ftp.isi.edu/in-notes/rfc1185.txt, October 1990, pages 1-21	
	30-4	V. Jacobson, et al. "TCP Extensions for High Performance", Request for Comments 1323, ftp://ftp.isi.edu/in-notes/rfc1323.txt, May 1992, pages 1-37	
	30-5	Vinton G. Cerf, "Packet Satellite Technology Reference Sources", Request for Comments 829, November 1982, http://www.cis.ohio-state.edu/htbin/rfc/rfc829.html, pages 1-5	
	30-6	VocalTec Internet Phone (TM) Version 2.5 Readme, VocalTec Ltd., 02/1995, 5 pages.	
	30-7	Written Opinion issued February 12, 1998 in corresponding International Application Serial No. PCT/US96/15504.	

Examiner Signature	/Alexander Kosowski/	Date Considered	05/03/2010
--------------------	----------------------	-----------------	------------

\*Examiner: Initial if reference was considered, whether or not citation is in conformance with MPEP 609. Draw a line through citation if not in conformance and not considered. Include a copy of this form with next communication to applicant. Notes: If identified, the following is provided: EA = English Abstract, T = Translation, PF = Patent Family.

<b>INFORMATION DISCLOSURE STATEMENT BY APPLICANT</b> FORM PTO-1449 (modified)	Reexam number	90/010,416
	First Named Inventor	Hutton
	Patent Under Re-Exam	6108704
	Issue Date	2000/08/22
	Group Art Unit	3992
	Examiner Name	KOSOWSKI, ALEXANDER J
	Attorney Docket No.	2655-0188
	Confirmation No.	1061

Sheet 1 of 10

FOREIGN PATENT DOCUMENTS					
Examiner Initials*	Cite No.	Document No.	Publication Date	Name of Patentee or Applicant of Cited Document	Notes
	1-1	WO-9003074	03-22-1990	LE CLERCQ, Patrick	
	1-2				
	1-3				
	1-4				
	1-5				
	1-6				
	1-7				
	1-8				
	1-9				
	1-10				
	1-11				
	1-12				
	1-13				
	1-14				
	1-15				
	1-16				
	1-17				
	1-18				
	1-19				
	1-20				
	1-21				
	1-22				
	1-23				
	1-24				

Examiner Signature	/Alexander Kosowski/	Date Considered	05/03/2010
--------------------	----------------------	-----------------	------------

\*Examiner: Initial if reference was considered, whether or not citation is in conformance with MPEP 609. Draw a line through citation if not in conformance and not considered. Include a copy of this form with next communication to applicant. Notes: If identified, the following is provided: EA = English Abstract, T = Translation, PF = Patent Family.

ALL REFERENCES CONSIDERED EXCEPT WHERE LINED THROUGH. /AK/

<b>INFORMATION DISCLOSURE STATEMENT BY APPLICANT</b> FORM PTO-1449 (modified)  Sheet 2 of 10	Reexam number	90/010,416
	First Named Inventor	Hutton
	Patent Under Re-Exam	6108704
	Issue Date	2000/08/22
	Group Art Unit	3992
	Examiner Name	KOSOWSKI, ALEXANDER J
	Attorney Docket No.	2655-0188
	Confirmation No.	1061

**NON-PATENT REFERENCES**

Examiner Initials*	Cite No.	Non-patent Reference bibliographic information, where available	Notes
	2-1	About NetPhone (undated)	
	2-2	After Downsizing: Overcoming Client-Server Chaos (May 21, 1994)	
	2-3	Barrow Street Research report on New Paradigm Software Corp. (dated sep. 20, 1995)	
	2-4	Camelot 10-Q for quarter ending January 31, 1995	
	2-5	Camelot Corporation 10-K, 1994	
	2-6	Camelot Corps Shining Internet Dream Draws Skeptics (Aug. 95)	
	2-7	Completed Beta Tester Agreements (May 1995)	

Examiner Signature		Date Considered	
--------------------	--	-----------------	--

\*Examiner: Initial if reference was considered, whether or not citation is in conformance with MPEP 609. Draw a line through citation if not in conformance and not considered. Include a copy of this form with next communication to applicant. Notes: If identified, the following is provided: EA = English Abstract, T = Translation, PF = Patent Family.

ALL REFERENCES CONSIDERED EXCEPT WHERE LINED THROUGH. /AK/

<b>INFORMATION DISCLOSURE STATEMENT BY APPLICANT</b> FORM PTO-1449 (modified)  Sheet 3 of 10	Reexam number	90/010,416
	First Named Inventor	Hutton
	Patent Under Re-Exam	6108704
	Issue Date	2000/08/22
	Group Art Unit	3992
	Examiner Name	KOSOWSKI, ALEXANDER J
	Attorney Docket No.	2655-0188
	Confirmation No.	1061

**NON-PATENT REFERENCES**

Examiner Initials*	Cite No.	Non-patent Reference bibliographic information, where available	Notes
	3-1	Correspondence with MacZone (Aug.-Sept. 1995)	
	3-2	DigiPhone and Camelot Documents	
	3-3	DigiPhone Documents (including Q and A) (prior to Sept. 1995)	
	3-4	DigiPhone Documents (prior to Sept. 1995)	
	3-5	DigiPhone for Mac (1996)	
	3-6	Electric Magic and Jabra Correspondence relating to new products (prior to 9/1995)	
	3-7	Electric Magic and PSINet License Negotiation Documentation (prior to Sept. 1995)	

Examiner Signature		Date Considered	
--------------------	--	-----------------	--

\*Examiner: Initial if reference was considered, whether or not citation is in conformance with MPEP 809. Draw a line through citation if not in conformance and not considered. Include a copy of this form with next communication to applicant. Notes: If identified, the following is provided: EA = English Abstract, T = Translation, PF = Patent Family.

ALL REFERENCES CONSIDERED EXCEPT WHERE LINED THROUGH. /AK/

<b>INFORMATION DISCLOSURE STATEMENT BY APPLICANT</b> FORM PTO-1449 (modified)  Sheet 4 of 10	Reexam number	90/010,416
	First Named Inventor	Hutton
	Patent Under Re-Exam	6108704
	Issue Date	2000/08/22
	Group Art Unit	3992
	Examiner Name	KOSOWSKI, ALEXANDER J
	Attorney Docket No.	2655-0188
	Confirmation No.	1061

**NON-PATENT REFERENCES**

Examiner Initials*	Cite No.	Non-patent Reference bibliographic information, where available	Notes
	4-1	Electric Magic Beta Tester Agreement dated July 21, 1995 (SKYPE-N2P01609523)	
	4-2	Electric Magic Company Releases NetPhone 1.2 and NetPub Server (dated June 8, 1995)	
	4-3	Electric Magic Information (May 1995)	
	4-4	Electric Magic Notebooks (prior to Sept. 1995)	
	4-5	Electric Magic Notes (including references to 4/18/95) and patent pending	
	4-6	Electric Magic Notes (including references to DigiPhone) (prior to Sept. 1995)	
	4-7	Electric Magic Notes (undated)	

Examiner Signature		Date Considered	
--------------------	--	-----------------	--

\*Examiner: Initial if reference was considered, whether or not citation is in conformance with MPEP 609. Draw a line through citation if not in conformance and not considered. Include a copy of this form with next communication to applicant. Notes: If identified, the following is provided: EA = English Abstract, T = Translation, PF = Patent Family.

ALL REFERENCES CONSIDERED EXCEPT WHERE LINED THROUGH. /AK/

<b>INFORMATION DISCLOSURE STATEMENT BY APPLICANT</b> FORM PTO-1449 (modified)  Sheet 5 of 10	Reexam number	90/010,416
	First Named Inventor	Hutton
	Patent Under Re-Exam	6108704
	Issue Date	2000/08/22
	Group Art Unit	3992
	Examiner Name	KOSOWSKI, ALEXANDER J
	Attorney Docket No.	2655-0188
	Confirmation No.	1061

NON-PATENT REFERENCES			
Examiner Initials*	Cite No.	Non-patent Reference bibliographic information, where available	Notes
	5-1	Electric Magic Press Release (dated Mar. 13, 1995)	
	5-2	ElectricMagic and WebKat Licensing Documents (Sept. 1995 and prior)	
	5-3	E-mail dated May 9, 1995 re NetPhone Development with Jabra R/D	
	5-4	Fax dated 5/31/95 to IVP including press releases	
	5-5	Google Groups comp.dcom.videoconf posting (dated Jul. 5, 1995)	
	5-6	intern.tex (dated Aug. 30, 1994)	
	5-7	Jabra - Corporate and Product Backgrounder (April 19, 1995)	

Examiner Signature		Date Considered	
--------------------	--	-----------------	--

\*Examiner: Initial if reference was considered, whether or not citation is in conformance with MPEP 609. Draw a line through citation if not in conformance and not considered. Include a copy of this form with next communication to applicant. Notes: If identified, the following is provided: EA = English Abstract, T = Translation, PF = Patent Family

ALL REFERENCES CONSIDERED EXCEPT WHERE LINED THROUGH. /AK/



<b>INFORMATION DISCLOSURE STATEMENT BY APPLICANT</b> FORM PTO-1449 (modified)  Sheet 6 of 10	Reexam number	90/010,416
	First Named Inventor	Hutton
	Patent Under Re-Exam	6108704
	Issue Date	2000/08/22
	Group Art Unit	3992
	Examiner Name	KOSOWSKI, ALEXANDER J
	Attorney Docket No.	2655-0188
	Confirmation No.	1061

**NON-PATENT REFERENCES**

Examiner Initials*	Cite No.	Non-patent Reference bibliographic information, where available	Notes
	6-1	Jabra Ear Phone Common Questions and Answers	
	6-2	Jabra Ear phone PC, 1995	
	6-3	Jabra Streamline Ear Phone, 1993	
	6-4	Letter of Intent including target dates (dated 19 Sept 95) (7 pgs)	
	6-5	List of source modules in NetPhone (dated Oct. 10, 1995)	
	6-6	MagicPhone Distribution Agreement (Aug. 1995)	
	6-7	Maven README (including 1994 copyright notice)	

Examiner Signature		Date Considered	
--------------------	--	-----------------	--

\*Examiner. Initial if reference was considered, whether or not citation is in conformance with MPEP 609. Draw a line through citation if not in conformance and not considered. Include a copy of this form with next communication to applicant. Notes: If identified, the following is provided. EA = English Abstract, T = Translation, PF = Patent Family.

ALL REFERENCES CONSIDERED EXCEPT WHERE LINED THROUGH. /AK/

<b>INFORMATION DISCLOSURE STATEMENT BY APPLICANT</b> FORM PTO-1449 (modified)  Sheet 7 of 10	Reexam number	90/010,416
	First Named Inventor	Hutton
	Patent Under Re-Exam	6108704
	Issue Date	2000/08/22
	Group Art Unit	3992
	Examiner Name	KOSOWSKI, ALEXANDER J
	Attorney Docket No.	2655-0188
	Confirmation No.	1061

NON-PATENT REFERENCES			
Examiner Initials*	Cite No	Non-patent Reference bibliographic information, where available	Notes
	7-1	Net as Phone (Internet World July 1995)	
	7-2	NET phone ad (with Jabra fax line) (May 95)	
	7-3	NetPhone 1.1 User Manual (including date 95-01-09)	
	7-4	NetPhone Advertisement (Aug. 1995)	
	7-5	NetPhone Correspondence (Jun.-July 1995)	
	7-6	NetPhone Development Plan (SKYPE-N2P01610487)	
	7-7	NetPhone Development Plan with time charts (including reference to 5/9/1995)	

Examiner Signature		Date Considered	
--------------------	--	-----------------	--

\*Examiner: Initial if reference was considered, whether or not citation is in conformance with MPEP 609. Draw a line through citation if not in conformance and not considered. Include a copy of this form with next communication to applicant. Notes: If identified, the following is provided: EA = English Abstract, T = Translation, PF = Patent Family.

ALL REFERENCES CONSIDERED EXCEPT WHERE LINED THROUGH. /AK/

<b>INFORMATION DISCLOSURE STATEMENT BY APPLICANT</b> FORM PTO-1449 (modified)  Sheet 8 of 10	Reexam number	90/010,416
	First Named Inventor	Hutton
	Patent Under Re-Exam	6108704
	Issue Date	2000/08/22
	Group Art Unit	3992
	Examiner Name	KOSOWSKI, ALEXANDER J
	Attorney Docket No.	2655-0188
	Confirmation No.	1061

NON-PATENT REFERENCES			
Examiner Initials*	Cite No.	Non-patent Reference bibliographic information, where available	Notes
	8-1	NetPhone Digital User Manual (dated 95-02-26)	
	8-2	NetPhone gives your Mac voice over the Internet (Inside the Internet - June 1995)	
	8-3	Netphone invoices (including invoices prior to 9/1995)	
	8-4	NetPhone Make Free Calls over the Internet (undated)	
	8-5	NetPhone Screenshots (undated)	
	8-6	NetPhone Tasks and Plans (dated Jan.-Feb. 1995)	
	8-7	New Paradigm Software Agreement (dated Oct. 9, 1995) referencing existing software as of that date	

Examiner Signature		Date Considered	
--------------------	--	-----------------	--

\*Examiner: Initial if reference was considered, whether or not citation is in conformance with MPEP 609. Draw a line through citation if not in conformance and not considered. Include a copy of this form with next communication to applicant. Notes: If identified, the following is provided. EA = English Abstract, T = Translation, PF = Patent Family.

ALL REFERENCES CONSIDERED EXCEPT WHERE LINED THROUGH. /AK/

<b>INFORMATION DISCLOSURE STATEMENT BY APPLICANT</b> FORM PTO-1449 (modified)  Sheet 9 of 10	Reexam number	90/010,416
	First Named Inventor	Hutton
	Patent Under Re-Exam	6108704
	Issue Date	2000/08/22
	Group Art Unit	3992
	Examiner Name	KOSOWSKI, ALEXANDER J
	Attorney Docket No.	2655-0188
	Confirmation No.	1061

NON-PATENT REFERENCES			
Examiner Initials*	Cite No.	Non-patent Reference bibliographic information, where available	Notes
	9-1	Open Systems Today, Feb. 20, 1995	
	9-2	Order for NetPhone version 1.2 labels (dated 6 June 95)	
	9-3	Phoneless Phoning April 2, 1995	
	9-4	PowWow Chunked Protocol Specification, Last edited 3/12/1999	
	9-5	PowWow Native Protocols, last updated Dec. 8, 1998	
	9-6	Roadmap for the Internet (March 1995)	
	9-7	SlipMagic Ad for MacZone (dated 9/28/1995) for selling product	

Examiner Signature		Date Considered	
--------------------	--	-----------------	--

\*Examiner: Initial if reference was considered, whether or not citation is in conformance with MPEP 609. Draw a line through citation if not in conformance and not considered. Include a copy of this form with next communication to applicant. Notes: If identified, the following is provided: EA = English Abstract, T = Translation, PF = Patent Family.

ALL REFERENCES CONSIDERED EXCEPT WHERE LINED THROUGH. /AK/

<b>INFORMATION DISCLOSURE STATEMENT BY APPLICANT</b> FORM PTO-1449 (modified)	Reexam number	90/010,416
	First Named Inventor	Hutton
	Patent Under Re-Exam	6108704
	Issue Date	2000/08/22
	Group Art Unit	3992
	Examiner Name	KOSOWSKI, ALEXANDER J
	Attorney Docket No.	2655-0188
	Confirmation No.	1061
Sheet 10 of 10		

NON-PATENT REFERENCES			
Examiner Initials*	Cite No.	Non-patent Reference bibliographic information, where available	Notes
	10-1	The Mac Zone (Catalog) dated 1995	
	10-2	Two-way voice calls over the Internet (11/21/94)	
	10-3	Ubique documents relating to Virtual Places Products (dated 1995 and March, 1995)	
	10-4	Ubique Ships Virtual Places Client and Server (dated March 20, 1995)	
	10-5	Ubique, Ltd. Fact Sheet (referencing NetPhone codecs and Vocaltec) (date unknown)	
	10-6	Undated Technical document	
	10-7	Welcome to NetPhone Demo (includes copyright date 1994)	

Examiner Signature	/Alexander Kosowski/	Date Considered	05/03/2010
--------------------	----------------------	-----------------	------------

\*Examiner: Initial if reference was considered, whether or not citation is in conformance with MPEP 609. Draw a line through citation if not in conformance and not considered. Include a copy of this form with next communication to applicant. Notes: If identified, the following is provided: EA = English Abstract, T = Translation, PF = Patent Family.

ALL REFERENCES CONSIDERED EXCEPT WHERE LINED THROUGH. /AK/

<b>INFORMATION DISCLOSURE STATEMENT BY APPLICANT</b> FORM PTO-1449 (modified)  Sheet 1 of 4	Reexam number	90/010,416
	First Named Inventor	Hutton
	Patent Under Re-Exam	6108704
	Issue Date	2000/08/22
	Group Art Unit	3992
	Examiner Name	KOSOWSKI, ALEXANDER J
	Attorney Docket No.	2655-0188
Confirmation No.	1061	

**NON-PATENT REFERENCES**

Examiner Initials*	Cite No.	Non-patent Reference bibliographic information, where available	Notes
	1-1	David STROM, "Talking Telephony", Windows Sources, Ziff-Davis Publishing Company, September 1996, Vol. 4, No. 9, pages 6, 7, 10, 150-152, 157, 158, 163, 167, 169, 171, 174, 181, 184, 186, 195, 203, 208.	
	1-2	Deposition transcript of Andrew Green (dated Aug. December 30, 2008) in <del>Net2Phone v. Skype et al. (Civil Action No. 06-2469-KSH-PS) in DCNJ</del>	
	1-3	Deposition transcript of Daniel Mayer (dated Aug. 26, 2008) in Net2Phone v. Skype et al. (Civil Action No. 06-2469-KSH-PS) in DCNJ	
	1-4	Deposition transcript of Daniel Zwanziger (dated July 9, 2008) in Net2Phone v. Skype et al. (Civil Action No. 06-2469-KSH-PS) in DCNJ	
	1-5	Deposition transcript of expert Bruce Maggs (dated May 30, 2008) in Net2Phone v. Skype et al. (Civil Action No. 06-2469-KSH-PS) in DCNJ	
	1-6	Deposition transcript of expert Kevin Jeffay (dated May 20, 2008) in Net2Phone v. Skype et al. (Civil Action No. 06-2469-KSH-PS) in DCNJ	
	1-7	Deposition transcript of expert Stephen Kunin (dated June 3, 2008) in Net2Phone v. Skype et al. (Civil Action No. 06-2469-KSH-PS) in DCNJ	

Examiner Signature	/Alexander Kosowski/	Date Considered	05/03/2010
--------------------	----------------------	-----------------	------------

\*Examiner: Initial if reference was considered, whether or not citation is in conformance with MPEP 609. Draw a line through citation if not in conformance and not considered. Include a copy of this form with next communication to applicant. Notes: If identified, the following is provided: EA = English Abstract, T = Translation, PT = Partial Translation, SOR = Statement of Relevancy, PF = Patent Family.

ALL REFERENCES CONSIDERED EXCEPT WHERE LINED THROUGH. /AK/

<b>INFORMATION DISCLOSURE STATEMENT BY APPLICANT</b> FORM PTO-1449 (modified)  Sheet 2 of 4	Reexam number	90/010,416
	First Named Inventor	Hutton
	Patent Under Re-Exam	6108704
	Issue Date	2000/08/22
	Group Art Unit	3992
	Examiner Name	KOSOWSKI, ALEXANDER J
	Attorney Docket No.	2655-0188
	Confirmation No.	1061

NON-PATENT REFERENCES			
Examiner Initials*	Cite No.	Non-patent Reference bibliographic information, where available	Notes
	2-1	Deposition transcript of former Tribal Voice employee and PowWow designer Paul Potereen (dated Apr. 9, 2008) in Net2Phone v. Skype et al. (Civil Action No. 06-2469-KSH-PS) in DCNJ	
	2-2	Deposition transcript of former VocalTec employee Alon Cohen (dated Mar. 11, 2008) in Net2Phone v. Skype et al. (Civil Action No. 06-2469-KSH-PS) in DCNJ	
	2-3	Deposition transcript of former VocalTec employee Lior Haramaty (dated Mar. 6, 2008) in Net2Phone v. Skype et al. (Civil Action No. 06-2469-KSH-PS) in DCNJ	
	2-4	Deposition transcript of inventor Craig Strickland (dated Sep. 19, 2007) in Net2Phone v. Skype et al. (Civil Action No. 06-2469-KSH-PS) in DCNJ	
	2-5	Deposition transcript of inventor Glenn Hutton (dated Aug. 24, 2007) (vol. 1) in Net2Phone v. Skype et al. (Civil Action No. 06-2469-KSH-PS) in DCNJ	
	2-6	Deposition transcript of inventor Glenn Hutton (dated Aug. 24, 2007) (vol. 2) in Net2Phone v. Skype et al. (Civil Action No. 06-2469-KSH-PS) in DCNJ	
	2-7	Deposition transcript of inventor Shane Mattaway (dated Sep. 10, 2007) (vol. 1) in Net2Phone v. Skype et al. (Civil Action No. 06-2469-KSH-PS) in DCNJ	

Examiner Signature		Date Considered	
--------------------	--	-----------------	--

\*Examiner: Initial if reference was considered, whether or not citation is in conformance with MPEP 609. Draw a line through citation if not in conformance and not considered. Include a copy of this form with next communication to applicant. Notes: If identified, the following is provided: EA = English Abstract, T = Translation, PT = Partial Translation, SOR = Statement of Relevancy, PF = Patent Family.

ALL REFERENCES CONSIDERED EXCEPT WHERE LINED THROUGH. /AK/

<b>INFORMATION DISCLOSURE STATEMENT BY APPLICANT</b> FORM PTO-1449 (modified)  Sheet 3 of 4	Reexam number	90/010,416
	First Named Inventor	Hutton
	Patent Under Re-Exam	6108704
	Issue Date	2000/08/22
	Group Art Unit	3992
	Examiner Name	KOSOWSKI, ALEXANDER J
	Attorney Docket No.	2655-0188
	Confirmation No.	1061

**NON-PATENT REFERENCES**

Examiner Initials*	Cite No.	Non-patent Reference bibliographic information, where available	Notes
	3-1	Deposition transcript of inventor Shane Mattaway (dated Sep. 10, 2007) (vol. 2) in <del>Net2Phone v. Skype et al. (Civil Action No. 06-2469-KSH-PS) in DCN.I</del>	
	3-2	Deposition transcript of prosecuting attorney Bruce Jobse (dated Jan. 1, 2008) in <del>Net2Phone v. Skype et al. (Civil Action No. 06-2469-KSH-PS) in DCN.I</del>	
	3-3	Deposition transcript of Sheldon Glashow (dated July 16, 2008) in <del>Net2Phone v. Skype et al. (Civil Action No. 06-2469-KSH-PS) in DCN.I</del>	
	3-4	Emad FARAG et al., "Structure and network control of a hierarchical mobile network architecture", IEEE Fourteenth Annual International Phoenix Conference on Computers and Communications, 03/1995, ISBN: 0-7803-2492-7, pp. 671-677.	
	3-5	English translation of JP-06-62020 (dated 1994-03-04)	
	3-6	Huanxu PAN et al., "Analysis of a CCSS#7 Network supporting database services", IEEE International Conference on Information Engineering, 09/1993, ISBN: 0-7803-1445-X, pp. 193-197, vol. 1.	
	3-7	John E. GOODWIN, Project Gutenberg Alpha Edition of EMAIL 101, <a href="http://metalab.unc.edu/pub/docs/books/gutenberg/etext93/email025.txt">http://metalab.unc.edu/pub/docs/books/gutenberg/etext93/email025.txt</a> , July 1993.	

Examiner Signature		Date Considered	
-----------------------	--	--------------------	--

\*Examiner: Initial if reference was considered, whether or not citation is in conformance with MPEP 609. Draw a line through citation if not in conformance and not considered. Include a copy of this form with next communication to applicant. Notes: If identified, the following is provided. EA = English Abstract, T = Translation, PT = Partial Translation, SOR = Statement of Relevancy, PF = Patent Family.

ALL REFERENCES CONSIDERED EXCEPT WHERE LINED THROUGH. /AK/



<b>INFORMATION DISCLOSURE STATEMENT BY APPLICANT</b> FORM PTO-1449 (modified)  Sheet 4 of 4	Reexam number	90/010,416
	First Named Inventor	Hutton
	Patent Under Re-Exam	6108704
	Issue Date	2000/08/22
	Group Art Unit	3992
	Examiner Name	KOSOWSKI, ALEXANDER J
	Attorney Docket No.	2655-0188
	Confirmation No.	1061

NON-PATENT REFERENCES			
Examiner Initials*	Cite No.	Non-patent Reference bibliographic information, where available	Notes
	4-1	Junichi Kimura, et al. "Voice/Data Multiplexing Transmission Methods", Kokai Japanese Patent, Kokai Sho 59-44140, pages 205-215, with English Abstract, English Translation, pages 1-24	
	4-2	Mark R. BROWN et al. "Special Edition: Using Netscape 2", Que Publishing, 1995, ISBN 0-7897-0612-1, pages 7-35, 37-56, 78, 83, 176, 301-320, 393, 395-467, 469-506.	
	4-3	Preston GRALLA, "How the Internet Works", Ziff-Davis Press, Emeryville, CA, c1997, pp. 34-37, 202-205, 214-215 and 272-275, ISBN 1-56276-552-3.	
	4-4		
	4-5		
	4-6		
	4-7		

Examiner Signature	/Alexander Kosowski/	Date Considered	05/03/2010
--------------------	----------------------	-----------------	------------

\*Examiner: Initial if reference was considered, whether or not citation is in conformance with MPEP 609. Draw a line through citation if not in conformance and not considered. Include a copy of this form with next communication to applicant. Notes: If identified, the following is provided: EA = English Abstract, T = Translation, PT = Partial Translation, SOR = Statement of Relevancy, PF = Patent Family.

ALL REFERENCES CONSIDERED EXCEPT WHERE LINED THROUGH. /AK/

<b>INFORMATION DISCLOSURE STATEMENT BY APPLICANT</b> FORM PTO-1449 (modified)  Sheet 1 of 1	Reexam number	90/010,416
	First Named Inventor	Hutton
	Patent Under Re-Exam	6108704
	Issue Date	2000/08/22
	Group Art Unit	3992
	Examiner Name	KOSOWSKI, ALEXANDER J
	Attorney Docket No.	2655-0188
	Confirmation No.	1061

NON-PATENT REFERENCES			
Examiner Initials*	Cite No.	Non-patent Reference bibliographic information, where available	Notes
	1-1	(Redacted) Expert Report of Professor Bruce M. Maggs (as Supplemented Sept. 9, 2008) in Net2Phone v. Skype et al. (Civil Action No. 06-2469-KSH-PS) in DCNJ	
	1-2	(Redacted) Responsive Expert Report of Kevin Jeffay, Ph.D. in Net2Phone v. Skype et al. (Civil Action No. 06-2469-KSH-PS) in DCNJ, Aug. 7, 2008	
/AK/	1-3	VocalChat GTI Information file, believed to be included with VocalChat GTI version 2.12 dated September, 1994	
/AK/	1-4	VocalChat GTI README.TXT for Version 2.12 Beta, dated September, 1994	
/AK/	1-5	VocalChat GTI Troubleshooting.Inf, believed to be included with VocalChat GTI version 2.12 dated September, 1994	
	1-6		
	1-7		

Examiner Signature	/Alexander Kosowski/	Date Considered	05/03/2010
--------------------	----------------------	-----------------	------------

\*Examiner: Initial if reference was considered, whether or not citation is in conformance with MPEP 609. Draw a line through citation if not in conformance and not considered. Include a copy of this form with next communication to applicant. Notes: If identified, the following is provided: EA = English Abstract, T = Translation, PF = Patent Family.

RECEIVED

MAR 05 2010

CENTRAL

<b>INFORMATION DISCLOSURE STATEMENT BY APPLICANT</b> FORM PTO-1449 (modified)	Reexam number	90/010,416
	First Named Inventor	Hutton
	Patent Under Re-Exam	6108704
	Issue Date	2000/08/22
	Group Art Unit	3992
	Examiner Name	KOSOWSKI, ALEXANDER J
	Attorney Docket No.	2655-0188
Sheet 1 of 1	Confirmation No.	1061

NON-PATENT REFERENCES			
Examiner Initials*	Cite No.	Non-patent Reference bibliographic information, where available	Notes
	1-1	<del>CD-ROM including VocalChat GTI Version 2.12 Software (including .hlp files and README.TXT file), alleged to be dated September, 1994</del>	
	1-2		
	1-3		
	1-4		
	1-5		
	1-6		
	1-7		

Examiner Signature	/Alexander Kosowski/	Date Considered	05/03/2010
--------------------	----------------------	-----------------	------------

\*Examiner: Initial if reference was considered, whether or not citation is in conformance with MPEP 809. Draw a line through citation if not in conformance and not considered. Include a copy of this form with next communication to applicant. Notes: If identified, the following is provided: EA = English Abstract, T = Translation, PT = Partial Translation, SOR = Statement of Relevancy, PF = Patent Family.

<b>INFORMATION DISCLOSURE STATEMENT BY APPLICANT</b> FORM PTO-1449 (modified)  Sheet 1 of 1	Reexam number	90/010,416
	First Named Inventor	Hutton
	Patent Under Re-Exam	6108704
	Issue Date	2000/08/22
	Group Art Unit	3992
	Examiner Name	KOSOWSKI, ALEXANDER J
	Attorney Docket No.	2655-0188
	Confirmation No.	1061

**NON-PATENT REFERENCES**

Examiner Initials*	Cite No.	Non-patent Reference bibliographic information, where available	Notes
	1-1	Notice Of Motion To Transfer Venue To The Western District of Arkasas, Civ. Action No. 06-2489	
	1-2	Reply Brief In Further Support Of Net2Phone's Motion To Transfer Venue To The Western District Of Arkansas, Civ. Action No. 06-2469	
	1-3		
	1-4		
	1-5		
	1-6		
	1-7		

Examiner Signature	/Alexander Kosowski/	Date Considered	05/07/2010
--------------------	----------------------	-----------------	------------

\*Examiner: Initial if reference was considered, whether or not citation is in conformance with MPEP 609. Draw a line through citation if not in conformance and not considered. Include a copy of this form with next communication to applicant. Notes: If identified, the following is provided: EA = English Abstract, T = Translation, PT = Partial Translation, SOR = Statement of Relevancy, PF = Patent Family.

**This Page is Inserted by IFW Indexing and Scanning  
Operations and is not part of the Official Record**

**BEST AVAILABLE IMAGES**

Defective images within this document are accurate representations of the original documents submitted by the applicant.

Defects in the images include but are not limited to the items checked:

- BLACK BORDERS
- IMAGE CUT OFF AT TOP, BOTTOM OR SIDES
- FADED TEXT OR DRAWING
- BLURRED OR ILLEGIBLE TEXT OR DRAWING
- SKEWED/SLANTED IMAGES
- COLOR OR BLACK AND WHITE PHOTOGRAPHS
- GRAY SCALE DOCUMENTS
- LINES OR MARKS ON ORIGINAL DOCUMENT
- REFERENCE(S) OR EXHIBIT(S) SUBMITTED ARE POOR QUALITY
- OTHER:

**IMAGES ARE BEST AVAILABLE COPY.**

**As rescanning these documents will not correct the image problems checked, please do not report these problems to the IFW Image Problem Mailbox.**

<b>Search Notes</b>  	<b>Application/Control No.</b> 90010416	<b>Applicant(s)/Patent Under Reexamination</b> 6108704
	<b>Examiner</b> ALEXANDER J KOSOWSKI	<b>Art Unit</b> 3992

<b>SEARCHED</b>			
<b>Class</b>	<b>Subclass</b>	<b>Date</b>	<b>Examiner</b>

<b>SEARCH NOTES</b>		
<b>Search Notes</b>	<b>Date</b>	<b>Examiner</b>
Reviewed proposed prior art and prosecution history	5/4/10	AJK

<b>INTERFERENCE SEARCH</b>			
<b>Class</b>	<b>Subclass</b>	<b>Date</b>	<b>Examiner</b>

--	--

<b>Reexamination</b> 	<b>Application/Control No.</b> 90010416	<b>Applicant(s)/Patent Under Reexamination</b> 6108704
	<b>Certificate Date</b>	<b>Certificate Number</b>

**Requester Correspondence Address:**       Patent Owner       Third Party

Blakely Sokoloff Taylor & Zafman LLP  
 1279 Oakmead Parkway  
 Sunnyvale, CA 94085-4040

<b>LITIGATION REVIEW</b> <input checked="" type="checkbox"/>	AJK (examiner initials)	05/04/2010 (date)
<b>Case Name</b>		<b>Director Initials</b>
OPEN: 2:06cv2469 Net2phone v. Ebay		<i>Eric Prasad for GM</i>

<b>COPENDING OFFICE PROCEEDINGS</b>	
<b>TYPE OF PROCEEDING</b>	<b>NUMBER</b>
1. no copending proceeding	

--	--

IN THE UNITED STATES PATENT AND TRADEMARK OFFICE

In re PATENT APPLICATION OF:  
Net2Phone, Inc. (Patent No. 6,108,704)  
Control No.: 90/010,416  
Issue Date: August 22, 2000  
Title: **POINT-TO-POINT INTERNET  
PROTOCOL**

Attorney Docket: 2655-0188  
Group Art Unit: 3992  
Examiner: KOSOWSKI, Alexander  
Date: July 12, 2010  
Confirmation No.: 1061

RESPONSE TO FINAL REJECTION IN A RE-EXAMINATION

Hon. Commissioner of Patents  
P.O. Box 1450  
Alexandria, VA 22313-1450

Sir:

In response to the Office Action dated May 11, 2010, the Assignee hereby requests an automatic one-month extension of time so that the examiner may consider the filed response, and submits:

Claim Amendments starting on page 2; and  
Remarks/Arguments beginning on page 3 of this paper.



Re-Examination of Patent No. 6,108,704  
Control No.: 90/010,416  
Filed: February 24, 2009  
Reply to Office Action of May 11, 2010

AMENDMENTS TO THE CLAIMS

Please cancel the following claims in re-examination without prejudice as follows:

- 43. (Canceled)
- 44. (Canceled)

Re-Examination of Patent No. 6,108,704  
Control No.: 90/010,416  
Filed: February 24, 2009  
Reply to Office Action of May 11, 2010

### REMARKS/ARGUMENTS

Favorable reconsideration of the claims currently undergoing re-examination, in view of the present amendment and in light of the following discussion, is respectfully requested.

#### STATUS OF THE CLAIMS

Claims 1-7, 11-20 and 22-42 are pending and the subject of this re-examination. Claims 43 and 44 have been canceled herewith. No other claims have been added or amended. The cancellation of claims 43 and 44 is made without prejudice and in order to expedite prosecution as they are the only claims that remain rejected. However, the Assignee incorporates by reference the remarks from the previously filed rejection as to why the patentability of those claims should have been confirmed.

#### RESPONSE TO REJECTIONS

In the outstanding office action, claims 43 and 44 remained rejected, but the patentability of all remaining pending claims was confirmed. The cancellation of claims 43 and 44 renders moot all remaining rejections, and this re-examination proceeding should now terminate.

Re-Examination of Patent No. 6,108,704  
Control No.: 90/010,416  
Filed: February 24, 2009  
Reply to Office Action of May 11, 2010

Consequently, in light of the above discussions and the cancellation of claims 43 and 44, the patentability of the claims subject to re-examination should be indicated as confirmed. An early and favorable action to that effect is respectfully requested.

**CHARGE STATEMENT:** Deposit Account No. 501860, order no. 2655-0188.

The Commissioner is hereby authorized to charge any fee specifically authorized hereafter, or any missing or insufficient fee(s) filed, or asserted to be filed, or which should have been filed herewith or concerning any paper filed hereafter, and which may be required under Rules 16-18 (missing or insufficiencies only) now or hereafter relative to this application and the resulting Official Document under Rule 20, or credit any overpayment, to our Accounting/ Order Nos. shown above, for which purpose a duplicate copy of this sheet is attached.

**This CHARGE STATEMENT does not authorize charge of the issue fee until/unless an issue fee transmittal sheet is filed.**

<p>CUSTOMER NUMBER</p> <p><b>42624</b></p>	<p>Respectfully submitted,</p> <p>By: / Michael R. Casey /</p> <hr/> <p>Michael R. Casey, Ph.D. Registration No.: 40,294</p>
<p>Davidson Berquist Jackson &amp; Gowdey LLP 4300 Wilson Blvd., 7th Floor, Arlington, Virginia 22203 Main: (703) 894-6400 • FAX: (703) 894-6430</p>	

Re-Examination of Patent No. 6,108,704  
Control No.: 90/010,416  
Filed: February 24, 2009  
Reply to Office Action of May 11, 2010

CERTIFICATE OF SERVICE

The undersigned hereby certifies that, on July 12, 2010, the RESPONSE TO FINAL REJECTION IN A RE-EXAMINATION filed in Re-examination Control No. 90/010,416 was served by U.S. First Class Mail, postage pre-paid, on Requestor as follows:

Blakely, Sokoloff, Taylor & Zafman LLP  
1279 Oakmead Parkway  
Sunnyvale, CA 94085-4040

/ Michael R. Casey /

---

Michael R. Casey, Ph.D.

## Electronic Acknowledgement Receipt

<b>EFS ID:</b>	7995027
<b>Application Number:</b>	90010416
<b>International Application Number:</b>	
<b>Confirmation Number:</b>	1061
<b>Title of Invention:</b>	Point-to-Point Internet Protocol
<b>First Named Inventor/Applicant Name:</b>	6108704
<b>Customer Number:</b>	42624
<b>Filer:</b>	Michael R. Casey
<b>Filer Authorized By:</b>	
<b>Attorney Docket Number:</b>	2655-0188
<b>Receipt Date:</b>	12-JUL-2010
<b>Filing Date:</b>	17-FEB-2009
<b>Time Stamp:</b>	15:16:14
<b>Application Type:</b>	Reexam (Third Party)

### Payment information:

Submitted with Payment	no
------------------------	----

### File Listing:

Document Number	Document Description	File Name	File Size(Bytes)/ Message Digest	Multi Part /.zip	Pages (if appl.)
1	Amendment After Final	20100712_704_cover.pdf	78649 <small>31b771xc84c0894d1232c5c3c3967407ad9f db385</small>	no	1

### Warnings:

### Information:

2	Claims	20100712_704_claims.pdf	41349 01898f9bcb597c12e5a0a831e0b777ac75d4b8c6f	no	1
<b>Warnings:</b>					
<b>Information:</b>					
3	Applicant Arguments/Remarks Made in an Amendment	20100712_704_Remarks.pdf	209736 694959e7e6888d84473f64b0c66838747d62ebc	no	2
<b>Warnings:</b>					
<b>Information:</b>					
4	Reexam Certificate of Service	20100712_704_COS.pdf	60529 6da5c00ef61c96f2bd29347801f9ee9cddc333f0	no	1
<b>Warnings:</b>					
<b>Information:</b>					
<b>Total Files Size (in bytes):</b>				390263	
<p>This Acknowledgement Receipt evidences receipt on the noted date by the USPTO of the indicated documents, characterized by the applicant, and including page counts, where applicable. It serves as evidence of receipt similar to a Post Card, as described in MPEP 503.</p> <p><b><u>New Applications Under 35 U.S.C. 111</u></b>  If a new application is being filed and the application includes the necessary components for a filing date (see 37 CFR 1.53(b)-(d) and MPEP 506), a Filing Receipt (37 CFR 1.54) will be issued in due course and the date shown on this Acknowledgement Receipt will establish the filing date of the application.</p> <p><b><u>National Stage of an International Application under 35 U.S.C. 371</u></b>  If a timely submission to enter the national stage of an international application is compliant with the conditions of 35 U.S.C. 371 and other applicable requirements a Form PCT/DO/EO/903 indicating acceptance of the application as a national stage submission under 35 U.S.C. 371 will be issued in addition to the Filing Receipt, in due course.</p> <p><b><u>New International Application Filed with the USPTO as a Receiving Office</u></b>  If a new international application is being filed and the international application includes the necessary components for an international filing date (see PCT Article 11 and MPEP 1810), a Notification of the International Application Number and of the International Filing Date (Form PCT/RO/105) will be issued in due course, subject to prescriptions concerning national security, and the date shown on this Acknowledgement Receipt will establish the international filing date of the application.</p>					





UNITED STATES PATENT AND TRADEMARK OFFICE

UNITED STATES DEPARTMENT OF COMMERCE  
United States Patent and Trademark Office  
Address: COMMISSIONER FOR PATENTS  
P.O. Box 1450  
Alexandria, Virginia 22313-1450  
www.uspto.gov

APPLICATION NO.	FILING DATE	FIRST NAMED INVENTOR	ATTORNEY DOCKET NO.	CONFIRMATION NO.
90/010,416	02/17/2009	6108704	2655-0188	1061

42624 7590 07/20/2010

DAVIDSON BERQUIST JACKSON & GOWDEY LLP  
4300 WILSON BLVD., 7TH FLOOR  
ARLINGTON, VA 22203

EXAMINER

ART UNIT PAPER NUMBER

DATE MAILED: 07/20/2010

Please find below and/or attached an Office communication concerning this application or proceeding.





**DO NOT USE IN PALM PRINTER**

(THIRD PARTY REQUESTER'S CORRESPONDENCE ADDRESS)

Blakely Sokoloff Taylor & Zafman LLP

1279 Oakmead Parkway

Sunnyvale, CA 94085-4040

**EX PARTE REEXAMINATION COMMUNICATION TRANSMITTAL FORM**

REEXAMINATION CONTROL NO. 90/010,416.

PATENT NO. 6108704.

ART UNIT 3992.

Enclosed is a copy of the latest communication from the United States Patent and Trademark Office in the above identified *ex parte* reexamination proceeding (37 CFR 1.550(f)).

Where this copy is supplied after the reply by requester, 37 CFR 1.535, or the time for filing a reply has passed, no submission on behalf of the *ex parte* reexamination requester will be acknowledged or considered (37 CFR 1.550(g)).

<b>Notice of Intent to Issue Ex Parte Reexamination Certificate</b>	Control No.	Patent Under Reexamination	
	90/010,416	6108704	
	Examiner	Art Unit	
	ALEXANDER J. KOSOWSKI	3992	

-- The MAILING DATE of this communication appears on the cover sheet with the correspondence address --

1.  Prosecution on the merits is (or remains) closed in this *ex parte* reexamination proceeding. This proceeding is subject to reopening at the initiative of the Office or upon petition. Cf. 37 CFR 1.313(a). A Certificate will be issued in view of
  - (a)  Patent owner's communication(s) filed: 12 July 2010.
  - (b)  Patent owner's late response filed: \_\_\_\_\_
  - (c)  Patent owner's failure to file an appropriate response to the Office action mailed: \_\_\_\_\_
  - (d)  Patent owner's failure to timely file an Appeal Brief (37 CFR 41.31).
  - (e)  Other: \_\_\_\_\_

Status of *Ex Parte* Reexamination:

  - (f) Change in the Specification:  Yes  No
  - (g) Change in the Drawing(s):  Yes  No
  - (h) Status of the Claim(s):
    - (1) Patent claim(s) confirmed: 1-7, ~~11-20~~ and ~~22-42~~ 11-20, 22-31
    - (2) Patent claim(s) amended (including dependent on amended claim(s)): ~~11-10, 22, 23, 25, 27 and 30~~
    - (3) Patent claim(s) cancelled: 10, 21, 43 and 44.
    - (4) Newly presented claim(s) patentable: \_\_\_\_\_
    - (5) Newly presented cancelled claims: \_\_\_\_\_
2.  Note the attached statement of reasons for patentability and/or confirmation. Any comments considered necessary by patent owner regarding reasons for patentability and/or confirmation must be submitted promptly to avoid processing delays. Such submission(s) should be labeled: "Comments On Statement of Reasons for Patentability and/or Confirmation."
3.  Note attached NOTICE OF REFERENCES CITED (PTO-892).
4.  Note attached LIST OF REFERENCES CITED (PTO/SB/08).
5.  The drawing correction request filed on \_\_\_\_\_ is:  approved  disapproved.
6.  Acknowledgment is made of the priority claim under 35 U.S.C. § 119(a)-(d) or (f).
  - a)  All b)  Some\* c)  None of the certified copies have
    - been received.
    - not been received.
    - been filed in Application No. \_\_\_\_\_.
    - been filed in reexamination Control No. \_\_\_\_\_.
    - been received by the International Bureau in PCT Application No. \_\_\_\_\_.

\* Certified copies not received: \_\_\_\_\_
7.  Note attached Examiner's Amendment.
8.  Note attached Interview Summary (PTO-474).
9.  Other: \_\_\_\_\_

--	--	--

cc: Requester (if third party requester)

U.S. Patent and Trademark Office  
PTOL-469 (Rev.08-06)

Notice of Intent to Issue Ex Parte Reexamination Certificate

Part of Paper No 20100714

### DETAILED ACTION

1) This Office action addresses claims 1-7 and 10-44 of United States Patent Number 6,108,704 (Hutton et al), for which it has been determined in the Order Granting Ex Parte Reexamination (hereafter the "Order") mailed 3/11/09 that a substantial new question of patentability was raised in the Request for *Ex Parte* reexamination filed on 2/17/09 (hereafter the "Request"). This action is in response to the after final amendment filed 7/12/10. Claims 43-44 are currently canceled. Claims 10 and 21 are previously canceled. Claims 1-7, 11-20 and 22-42 are patentable and/or confirmed as noted in the final rejection mailed 5/11/10.

### STATEMENT OF REASONS FOR PATENTABILITY AND/OR CONFIRMATION

2) Claims 1-7, 11-20 and 22-42 are patentable and/or confirmed.

The following is an examiner's statement of reasons for confirmation of the claims found patentable in this reexamination proceeding:

Referring to claims 1, 2, 4, 11, 22, 32, 33, 35, the claims are patentable and/or confirmed over the prior art that was explained in the request and determined to raise a substantial new question of patentability in the order granting reexamination and over the prior art that was applied and discussed by the examiner in the present reexamination proceeding because that prior art does not explicitly teach program code for transmitting to the server a network protocol address received by the first process following connection to the computer network (claim 1), each network protocol address stored in the memory following connection of a respective process to the computer network (claim 2), each of the network protocol addresses received following connection of the respective process to the computer network (claim 4), receiving a

Art Unit: 3992

network protocol address of the first callee process over the computer network from the server (claim 11), program code for receiving a network protocol address of the first callee process over the computer network from the server (claim 22), the Internet Protocol address added to the list following connection of the process to the computer network (claim 32), the network protocol address of the corresponding process assigned to the process upon connection to the computer network (claim 33), the network protocol address of the corresponding process assigned to the process upon connection to the computer network (claim 38), in combination with the remaining elements or features of the claimed invention.

Referring to all other claims, the claims are dependent on patentable and/or confirmed independent claims, and are therefore also patentable and/or confirmed.

Art Unit: 3992

*Conclusion*

All correspondence relating to this ex parte reexamination proceeding should be directed as follows:

By U.S. Postal Service Mail to:

Mail Stop Ex Parte Reexam  
ATTN: Central Reexamination Unit  
Commissioner for Patents  
P.O. Box 1450  
Alexandria, VA 22313-1450

By FAX to:

(571) 273-9900  
Central Reexamination Unit

By hand to:

Customer Service Window  
Randolph Building  
401 Dulany St.  
Alexandria, VA 22314

By EFS-Web:

Registered users of EFS-Web may alternatively submit such correspondence via the electronic filing system EFS-Web, at

<https://portal.uspto.gov/authenticate/authenticateuserlocalepf.html>

EFS-Web offers the benefit of quick submission to the particular area of the Office that needs to act on the correspondence. Also, EFS-Web submissions are "soft scanned" (i.e., electronically uploaded) directly into the official file for the reexamination proceeding, which offers parties the opportunity to review the content of their submissions after the "soft scanning" process is complete.

Art Unit: 3992

Any inquiry concerning this communication or earlier communications from the Reexamination Legal Advisor or Examiner, or as to the status of this proceeding, should be directed to the Central Reexamination Unit at telephone number (571) 272-7705.

/Alexander J Kosowski/

Primary Examiner, Art Unit 3992



ESK

<b>INFORMATION DISCLOSURE STATEMENT BY APPLICANT</b> FORM PTO-1449 (modified)	Reexam number	90/010,416
	First Named Inventor	Hutton
	Patent Under Re-Exam	6108704
	Issue Date	2000/08/22
	Group Art Unit	3992
	Examiner Name	KOSOWSKI, ALEXANDER J
	Attorney Docket No.	2655-0188
Confirmation No.	1061	
Sheet 1 of 67		

U.S. PATENT DOCUMENTS				
Examiner Initials*	Cite No.	Document No.	Publication/ Issue Date	Name of Patentee or Applicant of Cited Document
	1-1	US-4313035	1982/01/26	Jordan et al.
	1-2	US-4423414	1983/12/27	Bryant et al.
	1-3	US-4491693	1985/01/01	Sano et al.
	1-4	US-4602132	1986/07/22	Nagatomi et al.
	1-5	US-4653090	1987/03/24	Hayden, C.
	1-6	US-4658093	1987/14/04	Hellman
	1-7	US-4706274	1987/11/10	Baker et al.
	1-8	US-4754479	1988/06/28	Bicknell et al.
	1-9	US-4755985	1988/07/05	Jayapalan et al.
	1-10	US-4758020	1988/07/05	Fodale
	1-11	US-4759056	1988/07/19	Akiyama
	1-12	US-4800488	1989/24/01	Agrawal et al.
	1-13	US-4823374	1989/04/18	Verlohr
	1-14	US-4827411	1989/05/02	Arrowood
	1-15	US-4899333	1990/06/02	Roediger
	1-16	US-4899373	1990/02/06	Lee et al.
	1-17	US-4914571	1990/04/03	Baratz et al.
	1-18	US-4928306	1990/05/22	Biswas et al.
	1-19	US-4953159	1990/08/28	Hayden, C.
	1-20	US-4962449	1990/10	Schlesinger
	1-21	US-5109403	1992/04/28	Sutphin
	1-22	US-5113499	1992/05	Ankney et al.
	1-23	US-5127001	1992/30/06	Steagall, et al.
	1-24	US-5134648	1992/07/28	Hochfield et al.

Examiner Signature	/Alexander Kosowski/	Date Considered	07/19/2010
--------------------	----------------------	-----------------	------------

\*Examiner: Initial if reference was considered, whether or not citation is in conformance with MPEP 809. Draw a line through citation if not in conformance and not considered. Include a copy of this form with next communication to applicant.

ALL REFERENCES CONSIDERED EXCEPT WHERE LINED THROUGH. /AK/ N2P-IDS00227

<b>INFORMATION DISCLOSURE STATEMENT BY APPLICANT</b> FORM PTO-1449 (modified)	Reexam number	90/010,416
	First Named Inventor	Hutton
	Patent Under Re-Exam	6108704
	Issue Date	2000/08/22
	Group Art Unit	3992
	Examiner Name	KOSOWSKI, ALEXANDER J
	Attorney Docket No.	2655-0188
Confirmation No.	1061	
Sheet 2 of 67		

U.S. PATENT DOCUMENTS				
Examiner Initials*	Cite No.	Document No.	Publication/ Issue Date	Name of Patentee or Applicant of Cited Document
	2-1	US-5136716	1992/08/04	Harvey et al.
	2-2	US-5153908	1992/10/06	Kakizawa et al.
	2-3	US-5159592	1992/10	Perkins
	2-4	US-5164988	1992/11/17	Matyas et al.
	2-5	US-5185860	1993/02/09	Wu
	2-6	US-5195086	1993/03/16	Baumgartner et al.
	<del>2-7</del>	<del>US-5301324</del>	<del>1994/04</del>	<del>Dewey et al.</del>
	2-8	US-5315705	1994/24/05	Iwami Naoko et al
	2-9	US-5319705	1994/07/06	Halter et al.
	2-10	US-5325524	1994/06/28	Black et al.
	2-11	US-5329619	1994/07/12	Page et al.
	2-12	US-5388213	1995/02/07	Oppenheimer et al.
	2-13	US-5402477	1995/03/28	McMahan et al.
	2-14	US-5402528	1995/03/28	Christopher et al.
	2-15	US-5408526	1995/04/18	McFarland et al.
	2-16	US-5408619	1995/04/18	Oran
	2-17	US-5425028	1995/13/06	Britton et al.
	2-18	US-5434913	1995/07	Tung et al.
	2-19	US-5440632	1995/08/08	Bacon et al.
	2-20	US-5452289	1995/09/19	Sharma et al.
	2-21	US-5461668	1995/10/24	Zdenek et al.
	2-22	US-5469500	1995/21/11	Satter et al.
	2-23	US-5475819	1995/12	Miller et al.
	2-24	US-5481720	1996/02/01	Loucks et al.

Examiner Signature		Date Considered	
--------------------	--	-----------------	--

\*Examiner: Initial if reference was considered, whether or not citation is in conformance with MPEP 609. Draw a line through citation if not in conformance and not considered. Include a copy of this form with next communication to applicant.

N2P-TDS00228

ALL REFERENCES CONSIDERED EXCEPT WHERE LINED THROUGH. /AK/



<b>INFORMATION DISCLOSURE STATEMENT BY APPLICANT</b> FORM PTO-1449 (modified)	Reexam number	90/010,416
	First Named Inventor	Hutton
	Patent Under Re-Exam	6108704
	Issue Date	2000/08/22
	Group Art Unit	3992
	Examiner Name	KOSOWSKI, ALEXANDER J
	Attorney Docket No.	2655-0188
	Confirmation No.	1061

Sheet 3 of 67

U.S. PATENT DOCUMENTS				
Examiner Initials*	Cite No.	Document No.	Publication/ Issue Date	Name of Patentee or Applicant of Cited Document
	3-1	US-5499295	1996/12/03	Cooper
	3-2	US-5502727	1996/03/26	Catanzaro et al.
	3-3	US-5515508	1996/05/07	Pettus et al.
	3-4	US-5533110	1996/02/07	Pinard et al.
	3-5	US-5555290	1996/09/10	McLeod et al.
	3-6	US-5608786	1997/04/03	Gordon
	3-7	US-5615257	1997/03/25	Pezzullo et al.
	3-8	US-5621789	1997/04/15	McCalmont et al.
	3-9	US-5627978	1997/05/06	Altom et al.
	3-10	US-5649184	1997/07	Miller et al.
	3-11	US-5671412	1997/09/23	Christiano
	3-12	US-5684951	1997/04/11	Goldman et al.
	3-13	US-5689641	1997/11/18	Ludwig et al.
	3-14	US-5692180	1997/11	Lee
	3-15	US-5724648	1998/03/03	Shaughnessy et al.
	3-16	US-5734828	1998/31/03	Pendse et al.
	3-17	US-5774656	1998/06/30	Hattori et al.
	3-18	US-5790803	1998/04/08	Kinoshita et al.
	3-19	US-5815665	1998/29/09	Teper et al.
	3-20	US-5819084	1998/10/08	Shapiro, E.
	3-21	US-5825865	1998/20/10	Oberlander et al.
	3-22	US-5844978	1998/12/01	Reuss et al.
	3-23	US-5883956	1999/03/16	Le et al.
	3-24	US-5953350	1999/09	Higgins

Examiner Signature		Date Considered	
--------------------	--	-----------------	--

\*Examiner: Initial if reference was considered, whether or not citation is in conformance with MPEP 609. Draw a line through citation if not in conformance and not considered. Include a copy of this form with next communication to applicant.

ALL REFERENCES CONSIDERED EXCEPT WHERE LINED THROUGH. /AK/ N2P-IDS00229

<b>INFORMATION DISCLOSURE STATEMENT BY APPLICANT</b> FORM PTO-1449 (modified)	Reexam number	90/010,416
	First Named Inventor	Hutton
	Patent Under Re-Exam	6108704
	Issue Date	2000/08/22
	Group Art Unit	3992
	Examiner Name	KOSOWSKI, ALEXANDER J
	Attorney Docket No.	2655-0188
Confirmation No.	1061	
Sheet 4 of 67		

U.S. PATENT DOCUMENTS				
Examiner Initials*	Cite No.	Document No.	Publication/ Issue Date	Name of Patentee or Applicant of Cited Document
	4-1	US-5956485	1999/09/21	Perlman
	4-2	US-6009469	1999/12	Mattaway et al.
	4-3	US-6031836	2000/02	Haserodt
	4-4	US-6047054	2000/04	Bayless et al.
	4-5	US-6067350	2000/05/23	Gordon, A.
	4-6	US-6108704	2000/08	Hutton et al.
	4-7	US-6131121	2000/10	Mattaway et al.
	4-8	US-6360268	2002/03/19	Pettus
	4-9	US-6513066	2003/01	Hutton et al.
	4-10	US-6701365	2004/02/03	Glenn W. Hutton
	4-11			
	4-12			
	4-13			
	4-14			
	4-15			
	4-16			
	4-17			
	4-18			
	4-19			
	4-20			
	4-21			
	4-22			
	4-23			
	4-24			

Examiner Signature		Date Considered	
--------------------	--	-----------------	--

\*Examiner: Initial if reference was considered, whether or not citation is in conformance with MPEP 609. Draw a line through citation if not in conformance and not considered. Include a copy of this form with next communication to applicant.

ALL REFERENCES CONSIDERED EXCEPT WHERE LINED THROUGH. /AK/ N2P-IDS00230

<b>INFORMATION DISCLOSURE STATEMENT BY APPLICANT</b> FORM PTO-1449 (modified)	Reexam number	90/010,416
	First Named Inventor	Hutton
	Patent Under Re-Exam	6108704
	Issue Date	2000/08/22
	Group Art Unit	3992
	Examiner Name	KOSOWSKI, ALEXANDER J
	Attorney Docket No.	2655-0188
Confirmation No.	1061	
Sheet 5 of 67		

FOREIGN PATENT DOCUMENTS					
Examiner Initials*	Cite No.	Document No.	Publication Date	Name of Patentee or Applicant of Cited Document	Notes
	5-1	EP-0455402-A2	11-06-1991	Hewlett-Packard Company	
	5-2	EP-0556012-A2	08-18-1993	Wada et al.	
	5-3	EP-0581722	02/02/1994	Yeda R&D Co., Ltd.	
	5-4	EPO 0497022A1	19920508	Jennings et al.	
	5-5	WO-9219054	10-29-1992	Ferdinand et al.	
	5-6				
	5-7				
	5-8				
	5-9				
	5-10				
	5-11				
	5-12				
	5-13				
	5-14				
	5-15				
	5-16				
	5-17				
	5-18				
	5-19				
	5-20				
	5-21				
	5-22				
	5-23				
	5-24				

Examiner Signature		Date Considered	
--------------------	--	-----------------	--

\*Examiner: Initial if reference was considered, whether or not citation is in conformance with MPEP 609. Draw a line through citation if not in conformance and not considered. Include a copy of this form with next communication to applicant. Notes: If identified, the following is provided: EA = English Abstract, T = Translation, PF = Patent Family.

ALL REFERENCES CONSIDERED EXCEPT WHERE LINED THROUGH. 7AK/ N2P-IDS00231

<b>INFORMATION DISCLOSURE STATEMENT BY APPLICANT</b> FORM PTO-1449 (modified)  Sheet 6 of 67	Reexam number	90/010,416
	First Named Inventor	Hutton
	Patent Under Re-Exam	6108704
	Issue Date	2000/08/22
	Group Art Unit	3992
	Examiner Name	KOSOWSKI, ALEXANDER J
	Attorney Docket No.	2655-0188
	Confirmation No.	1061

NON-PATENT REFERENCES			
Examiner Initials*	Cite No.	Non-patent Reference bibliographic information, where available	Notes
	6-1	"A Low Cost Solution for: Using your WAN as a Voice Communication Tool" VocalTec White Paper (dated 06/03/94)	
	6-2	"CyberPhone Announcement" Internet Posting in Newsgroups comp.speech, June 8, 1995.	
	6-3	"CyberPhoneI" Internet Posting in Newsgroups comp.speech, April 14, 1995.	
	6-4	"Electric Magic Company Provides Internet Alternative to Long-Distance Calls", Electric Magic Company Press Release (March 13, 1995)	
	6-5	"Electric Magic Company Releases NetPhone 1.2 and Netpub Server", Electric Magic Company Press Release (June 1995)	
	6-6	"Frequently-Asked Questions about Tribal Voices PowWow" Version 0.34, March 4, 1996.	
	6-7	"Frequently-Asked Questions about Tribal Voices PowWow" Version 0.43, May 1, 1996.	

Examiner Signature		Date Considered	
--------------------	--	-----------------	--

\*Examiner: Initial if reference was considered, whether or not citation is in conformance with MPEP 609. Draw a line through citation if not in conformance and not considered. Include a copy of this form with next communication to applicant. Notes: If identified, the following is provided: EA = English Abstract, T = Translation, PF = Patent Family.

ALL REFERENCES CONSIDERED EXCEPT WHERE LINED THROUGH. /AK/ N2P-IDS00232

<b>INFORMATION DISCLOSURE STATEMENT BY APPLICANT</b> FORM PTO-1449 (modified)	Reexam number	90/010,416
	First Named Inventor	Hutton
	Patent Under Re-Exam	6108704
	Issue Date	2000/08/22
	Group Art Unit	3992
	Examiner Name	KOSOWSKI, ALEXANDER J
	Attorney Docket No.	2655-0188
Confirmation No.	1061	
Sheet 7 of 67		

NON-PATENT REFERENCES			
Examiner Initials*	Cite No.	Non-patent Reference bibliographic information, where available	Notes
	7-1	"Frequently-Asked Questions about Tribal Voices PowWow" Version 0.45, May 31, 1996.	
	7-2	"Frequently-Asked Questions about Tribal Voices PowWow" Version 0.47, June 12, 1996.	
	7-3	"Frequently-Asked Questions about Tribal Voices PowWow" Version 0.48, June 25, 1996.	
	7-4	"Frequently-Asked Questions about Tribal Voices PowWow" Version 0.59, October 30, 1996.	
	7-5	"NetPhone Gets Internet Users Talking at Local Rates" MacUser UK, March 3, 1995, pg. 27.	
	7-6	"NetPhone Gives Your Mac Voice Over the Internet" Inside the Internet Rocket Science for the Rest of Us. Vol. 2 Num. 3, June 1995.	
	7-7	"NetPhone" MacWorld, July 1995.	

Examiner Signature		Date Considered	
--------------------	--	-----------------	--

\*Examiner: Initial if reference was considered, whether or not citation is in conformance with MPEP 609. Draw a line through citation if not in conformance and not considered. Include a copy of this form with next communication to applicant. Notes: If identified, the following is provided: EA = English Abstract, T = Translation, PF = Patent Family.

ALL REFERENCES CONSIDERED EXCEPT WHERE LINED THROUGH. /AK/ N2P-IDS00233

<b>INFORMATION DISCLOSURE STATEMENT BY APPLICANT</b> FORM PTO-1449 (modified)	Reexam number	90/010,416
	First Named Inventor	Hutton
	Patent Under Re-Exam	6108704
	Issue Date	2000/08/22
	Group Art Unit	3992
	Examiner Name	KOSOWSKI, ALEXANDER J
	Attorney Docket No.	2655-0188
Confirmation No.	1061	
Sheet 8 of 67		

NON-PATENT REFERENCES			
Examiner Initials*	Cite No.	Non-patent Reference bibliographic information, where available	Notes
	8-1	"NetPhone" West Coast Online, Ver. 3.02 (#26), April 1995.	
	8-2	"PowWow 1.3b Now Available!" Google Newsgroup comp.os.ms-windows.misc Discussion Posting (dated April 22, 1995)	
	8-3	1996-1997 Buyer's Guide, CTI for Management	
	8-4	Abbe Cohen, Inessential Zephyr (Aug. 23, 1993).	
	8-5	Adam Gaffin, VocalTec Ware Lets Users Make Voice Calls over 'Net, NETWORK WORLD (Feb. 13, 1995).	
	8-6	Alexander Schill, ed., DCE—The OSF Distributed Computer Environment: Client/Server Model and Beyond, Lecture Notes in Computer Science 731, Karlsruhe University (1993).	
	8-7	Analysis of DCE Security Draft (Sept. 18, 1996).	

Examiner Signature		Date Considered	
--------------------	--	-----------------	--

\*Examiner: Initial # reference was considered, whether or not citation is in conformance with MPEP 609. Draw a line through citation if not in conformance and not considered. Include a copy of this form with next communication to applicant. Notes: If identified, the following is provided: EA = English Abstract, T = Translation, PF = Patent Family.

ALL REFERENCES CONSIDERED EXCEPT WHERE LINED THROUGH. /AK/ N2P-IDS00234

<b>INFORMATION DISCLOSURE STATEMENT BY APPLICANT</b> FORM PTO-1449 (modified)	Reexam number	90/010,416
	First Named Inventor	Hutton
	Patent Under Re-Exam	6108704
	Issue Date	2000/08/22
	Group Art Unit	3992
	Examiner Name	KOSOWSKI, ALEXANDER J
	Attorney Docket No.	2655-0188
Confirmation No.	1061	
Sheet 9 of 67		

NON-PATENT REFERENCES			
Examiner Initials*	Cite No.	Non-patent Reference bibliographic information, where available	Notes
	9-1	Andrew D. Birrell, et al., Grapevine: An Exercise in Distributed Computing, Communications of the ACM (April 1982).	
	9-2	Andrew D. Birrell, et al., Grapevine: An Exercise in Distributed Computing, COMMUNICATIONS OF THE ACM, vol. 25, No. 4, Apr. 1982.	
	9-3	Andrew D. Birrell, et al., Implementing Remote Procedure Calls, ACM Transactions on Computer Systems (Feb. 1984).	
	9-4	Andrew S. Tanenbaum, COMPUTER NETWORKS, 2d ed. (Prentice-Hall, 1988).	
	9-5	Andy Patrizio, Telecom, Digital Limits Begin to Blur with 'Phone Calls' Across Internet, PC WEEK, vol. 12, no. 6 (Feb. 13, 1995).	
	9-6	Antonio Ruiz, Voice and Telephony Applications for the Office Workstation, IEEE 1st International Conference on Computer Workstations, San Jose, California (Nov. 11-14, 1985).	
	9-7	AVC-650: Technical Issues Concerning Real-Time Protocol in H.322 Systems in ATM and Other Packet-Switched Computer Networks, July 9, 1994.	

Examiner Signature		Date Considered	
--------------------	--	-----------------	--

\*Examiner: Initial if reference was considered, whether or not citation is in conformance with MPEP 609. Draw a line through citation if not in conformance and not considered. Include a copy of this form with next communication to applicant. Notes: If identified, the following is provided: EA = English Abstract, T = Translation, PF = Patent Family.

ALL REFERENCES CONSIDERED EXCEPT WHERE LINED THROUGH. /AK/ N2P-IDS00235

<b>INFORMATION DISCLOSURE STATEMENT BY APPLICANT</b> FORM PTO-1449 (modified)	Reexam number	90/010,416
	First Named Inventor	Hutton
	Patent Under Re-Exam	6108704
	Issue Date	2000/08/22
	Group Art Unit	3992
	Examiner Name	KOSOWSKI, ALEXANDER J
	Attorney Docket No.	2655-0188
Confirmation No.	1061	
Sheet 10 of 67		

NON-PATENT REFERENCES			
Examiner Initials*	Cite No.	Non-patent Reference bibliographic information, where available	Notes
	10-1	AVC-655: Communication Procedure for H.222.1, July 1, 1994.	
	10-2	AVC-666: H.32X Communication Modes, Terminal Types and Interworking Scenarios, July 1994.	
	10-3	AVC-683: Update Draft H.32Z Following Grimstad Meeting, Nov. 1994.	
	10-4	AVC-696: An Example of Call Setup Procedure in a H.32Z Terminal, Nov. 1994.	
	10-5	AVC-702: Terminal to Terminal Signaling in H.32X, Oct. 24, 1994.	
	10-6	AVC-707R: Report of the Seventeenth Experts Group Meeting in Singapore (1-11 July 1994) – Part I and Part II, Nov. 11, 1994.	
	10-7	AVC-716: Draft Recommendation H.32X, Jan. 1995.	

Examiner Signature		Date Considered	
--------------------	--	-----------------	--

\*Examiner: Initial if reference was considered, whether or not citation is in conformance with MPEP 609. Draw a line through citation if not in conformance and not considered. Include a copy of this form with next communication to applicant. Notes: If identified, the following is provided: EA = English Abstract, T = Translation, PF = Patent Family.

ALL REFERENCES CONSIDERED EXCEPT WHERE LINED THROUGH. /AK/ N2P-IDS00236



<b>INFORMATION DISCLOSURE STATEMENT BY APPLICANT</b> FORM PTO-1449 (modified)  Sheet 11 of 67	Reexam number	90/010,416
	First Named Inventor	Hutton.
	Patent Under Re-Exam	6108704
	Issue Date	2000/08/22
	Group Art Unit	3992
	Examiner Name	KOSOWSKI, ALEXANDER J
	Attorney Docket No.	2655-0188
	Confirmation No.	1061

NON-PATENT REFERENCES			
Examiner Initials*	Cite No.	Non-patent Reference bibliographic information, where available	Notes
	11-1	AVC-718: Draft H.32X, Jan. 1995.	
	11-2	AVC-743R: Report of the Eighteenth Experts Group Meeting in Kamifukuoka (24-27 January 1995), Jan. 27, 1995.	
	11-3	AVC-748: Update of Draft Recommendation H.322, May 1995.	
	11-4	AVC-750: Report of the Study Group 15 Meeting Held During 6-17 February 1995, Feb. 24, 1995.	
	11-5	AVC-752: Open Issues Towards the Stockholm Meeting, Mar. 17, 1995.	
	11-6	AVC-758: Draft Recommendation H.323 Visual Telephone Systems and Terminal Equipment for Local Area Networks Which Provide A Non-Guaranteed Quality of Service, Rev. May 12, 1995.	
	11-7	AVC-767: Logical Channel Set-up Procedure, Apr. 28, 1995.	

Examiner Signature		Date Considered	
--------------------	--	-----------------	--

\*Examiner: Initial if reference was considered, whether or not citation is in conformance with MPEP 609. Draw a line through citation if not in conformance and not considered. Include a copy of this form with next communication to applicant. Notes: If identified, the following is provided: EA = English Abstract, T = Translation, PF = Patent Family.

ALL REFERENCES CONSIDERED EXCEPT WHERE LINED THROUGH. /AK/ N2P-IDS00237

<b>INFORMATION DISCLOSURE STATEMENT BY APPLICANT</b> FORM PTO-1449 (modified)  Sheet 12 of 67	Reexam number	90/010,416
	First Named Inventor	Hutton
	Patent Under Re-Exam	6108704
	Issue Date	2000/08/22
	Group Art Unit	3992
	Examiner Name	KOSOWSKI, ALEXANDER J
	Attorney Docket No.	2655-0188
	Confirmation No.	1061

NON-PATENT REFERENCES			
Examiner Initials*	Cite No.	Non-patent Reference bibliographic information, where available	Notes
	12-1	AVC-799: Comments on Draft H.323 and H.22Z, May 11, 1995.	
	12-2	AVC-800R: Report of the Nineteenth Experts Group Meeting in Haninge (15-18 May 1995), May 18, 1995	
	12-3	AVC-813: Signaling Recommendation Within the Scope of H.323, Sept. 10, 1995.	
	12-4	AVC-819: LAN Addressing Plan in H.323, Sept. 10, 1995	
	12-5	AVC-830: Connection Management Procedures for H.323, Oct. 24-27, 1995.	
	12-6	AVC-842: Gateway, Gatekeeper and Terminal Procedures in H.323, Oct. 17, 1995.	
	12-7	Avnish Aggarwal, et al., RFC 1002: Protocol Standard for a NetBIOS Service on a TCP/UDP Transport: Detailed Specifications (Mar. 1987).	

Examiner Signature		Date Considered	
--------------------	--	-----------------	--

\*Examiner: Initial if reference was considered, whether or not citation is in conformance with MPEP 609. Draw a line through citation if not in conformance and not considered. Include a copy of this form with next communication to applicant. Notes: If identified, the following is provided: EA = English Abstract, T = Translation, PF = Patent Family.

ALL REFERENCES CONSIDERED EXCEPT WHERE LINED THROUGH. /AK/ N2P-IDS00238

<b>INFORMATION DISCLOSURE STATEMENT BY APPLICANT</b> FORM PTO-1449 (modified)	Reexam number	90/010,416
	First Named Inventor	Hutton
	Patent Under Re-Exam	6108704
	Issue Date	2000/08/22
	Group Art Unit	3992
	Examiner Name	KOSOWSKI, ALEXANDER J
	Attorney Docket No.	2655-0188
Confirmation No.	1061	
Sheet 13 of 67		

NON-PATENT REFERENCES			
Examiner Initials*	Cite No.	Non-patent Reference bibliographic information, where available	Notes
	13-1	Barbara Darrow, Internet Phone Chat Software Prompts Spat; IRC Operators Rebuffed Use of Their Systems, COMPUTER RESELLER NEWS (Mar. 20, 1995).	
	13-2	Barry Michael Arons, The Audio-Graphical Interface to a Personal Integrated Telecommunications System, Masters Thesis, Massachusetts Institute of Technology (June 1984).	
	13-3	Barry Phillips, Casting the Net for New Media, OEM MAGAZINE, no. 320 (1995).	
	13-4	Belville, Sharon, "Zephyr on Athena", Athena Documentation, September 10, 1991, Version 3.	
	13-5	Ben Mesander, et al., The Client-To-Client Protocol (Aug. 12, 1994).	
	13-6	Bill Welsh, H.245 Implementors' Guide (undated but references April 1996)	
	13-7	Bob Blakley's Email to sig-dce-security, DCE Delegation Proposal Review, July 7, 1992.	

Examiner Signature		Date Considered	
--------------------	--	-----------------	--

\*Examiner: Initial if reference was considered, whether or not citation is in conformance with MPEP 609. Draw a line through citation if not in conformance and not considered. Include a copy of this form with next communication to applicant. Notes: If identified, the following is provided: EA = English Abstract, T = Translation, PF = Patent Family.

ALL REFERENCES CONSIDERED EXCEPT WHERE LINED THROUGH. /AK/ N2P-IDS00239

<b>INFORMATION DISCLOSURE STATEMENT BY APPLICANT</b> FORM PTO-1449 (modified)  Sheet 14 of 67	Reexam number	90/010,416
	First Named Inventor	Hutton
	Patent Under Re-Exam	6108704
	Issue Date	2000/08/22
	Group Art Unit	3992
	Examiner Name	KOSOWSKI, ALEXANDER J
	Attorney Docket No.	2655-0188
	Confirmation No.	1061

NON-PATENT REFERENCES			
Examiner Initials*	Cite No.	Non-patent Reference bibliographic information, where available	Notes
	14-1	Brad Curtis Johnson, A Distributed Computing Environment Framework: An OSF Perspective (1991).	
	14-2	Brent Nordin, et al., Remote Operation Across a Network of Small Computers (Association of Computing Machinery, 1986).	
	14-3	Brian Fox, et al., GNU Finger program documentation, Free Software Foundation (1992).	
	14-4	Bruce Brown, BugNet Bug/Fix List, NEWSBYTES (Dec. 13, 1995).	
	14-5	Bruce Brown, BugNet Bug/Fix List, NEWSBYTES (Dec. 13, 1996).	
	14-6	Butler W. Lampson, et al., A Distributed Systems Architecture for the 1990's (Dec, 17, 1989).	
	14-7	Buy Memory Configured Expressly for Your Computer, SAN JOSE MERCURY NEWS (July 16, 1995).	

Examiner Signature		Date Considered	
--------------------	--	-----------------	--

\*Examiner: Initial if reference was considered, whether or not citation is in conformance with MPEP 609. Draw a line through citation if not in conformance and not considered. Include a copy of this form with next communication to applicant. Notes: If identified, the following is provided: EA = English Abstract, T = Translation, PF = Patent Family.

ALL REFERENCES CONSIDERED EXCEPT WHERE LINED THROUGH. /AK/ N2P-IDS00240

<b>INFORMATION DISCLOSURE STATEMENT BY APPLICANT</b> FORM PTO-1449 (modified)  Sheet 15 of 67	Reexam number	90/010,416
	First Named Inventor	Hutton
	Patent Under Re-Exam	6108704
	Issue Date	2000/08/22
	Group Art Unit	3992
	Examiner Name	KOSOWSKI, ALEXANDER J
	Attorney Docket No.	2655-0188
	Confirmation No.	1061

NON-PATENT REFERENCES			
Examiner Initials*	Cite No.	Non-patent Reference bibliographic information, where available	Notes
	15-1	C. Anthony DellaFera, et al., Section E.4.1: Zephyr Notification Service, ATHENA TECHNICAL PLAN (July 29, 1988).	
	15-2	C. Anthony DellaFera, et al., Section E.4.1: Zephyr Notification Service, Project Athena Technical Plan (June 5, 1989).	
	15-3	C. Anthony DellaFera, et al., The Athena Notification Service: Zephyr (1987).	
	15-4	C. Anthony DellaFera, et al., The Athena Notification Service: Zephyr (Dec. 31, 1987).	
	15-5	C. Anthony DellaFera, et al., The Zephyr Notification Service (undated).	
	15-6	C. Anthony DellaFera, et al., The Zephyr Notification Service, USENIX Winter Conference, Feb. 9-12, 1988	
	15-7	C. Anthony DellaFera, The Zephyr Notification Service, MIT Project Athena, Winter Usenix Conference (Feb. 12, 1988).	

Examiner Signature		Date Considered	
--------------------	--	-----------------	--

\*Examiner: Initial if reference was considered, whether or not citation is in conformance with MPEP 609. Draw a line through citation if not in conformance and not considered. Include a copy of this form with next communication to applicant. Notes: If identified, the following is provided: EA = English Abstract, T = Translation, PF = Patent Family.

ALL REFERENCES CONSIDERED EXCEPT WHERE LINED THROUGH. /AK/ N2P-TDS00241

<b>INFORMATION DISCLOSURE STATEMENT BY APPLICANT</b> FORM PTO-1449 (modified)  Sheet 16 of 67	Reexam number	90/010,416
	First Named Inventor	Hutton
	Patent Under Re-Exam	6108704
	Issue Date	2000/08/22
	Group Art Unit	3992
	Examiner Name	KOSOWSKI, ALEXANDER J
	Attorney Docket No.	2655-0188
	Confirmation No.	1061

NON-PATENT REFERENCES			
Examiner Initials*	Cite No.	Non-patent Reference bibliographic information, where available	Notes
	16-1	C. Malamud, et al., RFC 1528: Principles of Operation for the TPC.INT Subdomain: Technical Procedures (Oct. 1993).	
	16-2	C. Malamud, et al., RFC 1530: Principles of Operation for the TPC.INT Subdomain: General Principles and Policy (Oct. 1993).	
	16-3	C. Sunshine, et al., IEN 135: Addressing Mobile Hosts in the ARPA Internet Environment (Oct. 1985).	
	16-4	C. Yang, RFC 1789: INETPhone: Telephone Services and Servers on Internet (Apr. 1995).	
	16-5	Calls Waiting on the Internet Although Telephone Software Makes 'Free' Long Distance Possible, it's a Long Way from Practical, KANSAS CITY STAR (July 14, 1996).	
	16-6	Carl Sunshine, IEN 178: Addressing Problems in Multi-Network Systems (Apr. 1981).	
	16-7	Charles E. Perkins, et al., A Mobile Networking System Based on Internet Protocol, IEEE PERSONAL COMMUNICATIONS (First Quarter 1994).	

Examiner Signature		Date Considered	
--------------------	--	-----------------	--

\*Examiner: Initial if reference was considered, whether or not citation is in conformance with MPEP 609. Draw a line through citation if not in conformance and not considered. Include a copy of this form with next communication to applicant. Notes: If identified, the following is provided: EA = English Abstract, T = Translation, PF = Patent Family.

ALL REFERENCES CONSIDERED EXCEPT WHERE LINED THROUGH. /AK/ NTP-TDS00242

<b>INFORMATION DISCLOSURE STATEMENT BY APPLICANT</b> FORM PTO-1449 (modified)  Sheet 17 of 67	Reexam number	90/010,416
	First Named Inventor	Hutton
	Patent Under Re-Exam	6108704
	Issue Date	2000/08/22
	Group Art Unit	3992
	Examiner Name	KOSOWSKI, ALEXANDER J
	Attorney Docket No.	2655-0188
	Confirmation No.	1061

NON-PATENT REFERENCES			
Examiner Initials*	Cite No.	Non-patent Reference bibliographic information, where available	Notes
	17-1	Charlie Kaufman's Email to dmackey re DCE 1.1 Delegation Proposal for Review, June 22, 1992.	
	17-2	Chii-Ren Tsai, et al., Distributed Audit with Secure Remote Procedure Calls (1991).	
	17-3	Christopher Schmandt, et al., An Audio and Telephone Server for Multi-Media Workstations, IEEE (1988).	
	17-4	Christopher Schmandt, et al., Phone Slave: A Graphical Telecommunications Interface, Society for Information Display, 1984 International Symposium Digest of Technical Papers (June 1984).	
	17-5	Chuck Kane, List of IRC servers as of Feb. 1, 1995, available at <a href="http://fp.funet.fi/pub/unix/irc/does/servers.950201">http://fp.funet.fi/pub/unix/irc/does/servers.950201</a> .	
	17-6	Clinton Wilder, Pulling in the Net - InfoSeek, VocalTec Offer Search and Voice Options to Internet Users Online, INFORMATIONWEEK, no. 516 (1995).	
	17-7	Common Desktop Environment 1.0—Advanced User's and System Administrator's Guide, Addison-Wesley Publishing Co. (1995).	

Examiner Signature		Date Considered	
--------------------	--	-----------------	--

\*Examiner: Initial if reference was considered, whether or not citation is in conformance with MPEP 609. Draw a line through citation if not in conformance and not considered. Include a copy of this form with next communication to applicant. Notes: If identified, the following is provided: EA = English Abstract, T = Translation, PF = Patent Family.

ALL REFERENCES CONSIDERED EXCEPT WHERE LINED THROUGH. <sup>N2B TDS00243</sup> /AK/

<b>INFORMATION DISCLOSURE STATEMENT BY APPLICANT</b> FORM PTO-1449 (modified)  Sheet 18 of 67	Reexam number	90/010,416
	First Named Inventor	Hutton
	Patent Under Re-Exam	6108704
	Issue Date	2000/08/22
	Group Art Unit	3992
	Examiner Name	KOSOWSKI, ALEXANDER J
	Attorney Docket No.	2655-0188
	Confirmation No.	1061

NON-PATENT REFERENCES			
Examiner Initials*	Cite No.	Non-patent Reference bibliographic information, where available	Notes
	18-1	Common Desktop Environment 1.0—User's Guide, Addison-Wesley Publishing Co. (1995).	
	18-2	Communications Connectivity Networking, MICROSOFT SYSTEMS JOURNAL, vol. 10, no. 1 (Jan. 1995).	
	18-3	Comp.Speech FAQ Archive; Comp.Speech FAQ Web Page, COMP.SPEECH NEWSGROUP. July 17, 1995)	
	18-4	Comp.Speech FAQ Weekly Reminder, COMP.SPEECH NEWSGROUP (June 21, 1995)	
	18-5	Contents, Preface, and Index to Open Software Foundation, X/Open Preliminary Specification—X/Open DCE: Authentication and Security Services (March 1996).	
	18-6	Conversation Excerpt from ftp://svr-ftp.eng.cam.ac.uk/pub/pub/comp.speech/archive/subject5xxx.txt accessed on 11/28/2007	
	18-7	Craig Crossman, Free Calls on Internet are CB-Style No Longer, MIAMI HERALD (June 26, 1995).	

Examiner Signature		Date Considered	
--------------------	--	-----------------	--

\*Examiner: Initial if reference was considered, whether or not citation is in conformance with MPEP 609. Draw a line through citation if not in conformance and not considered. Include a copy of this form with next communication to applicant. Notes: If identified, the following is provided: EA = English Abstract, Y = Translation, PF = Patent Family.

ALL REFERENCES CONSIDERED EXCEPT WHERE LINED THROUGH. TAK/ N2P-IDS00244



<b>INFORMATION DISCLOSURE STATEMENT BY APPLICANT</b> FORM PTO-1449 (modified)  Sheet 19 of 67	Reexam number	90/010,416
	First Named Inventor	Hutton
	Patent Under Re-Exam	6108704
	Issue Date	2000/08/22
	Group Art Unit	3992
	Examiner Name	KOSOWSKI, ALEXANDER J
	Attorney Docket No.	2655-0188
Confirmation No.	1061	

NON-PATENT REFERENCES			
Examiner Initials*	Cite No.	Non-patent Reference bibliographic information, where available	Notes
	19-1	Craig Crossman, Make Long Distance Calls Via the Internet, RECORD (July 3, 1995).	
	19-2	D. O'Mahoney, 1st Generation Internet Phones (1998).	
	19-3	D. Reed, RFC 1324: A Discussion on Computer Network Conferencing (May 1992).	
	19-4	D. Zimmerman, RFC 1288: The Finger User Information Protocol (Dec. 1991).	
	19-5	Dale Skran, Draft ITU-T Recommendation H.225.0-- Line Transmission of Non-Telephone Signals, Media Stream Packetization and Synchronization on Non-Guaranteed Quality of Service LANs (May 28, 1996).	
	19-6	Dale Skran, ed. ASN.1 for H.225.0 (June 18, 1996).	
	19-7	Dan Cohen, IEN 31: On Name, Addresses and Routings (II) (Apr. 28, 1978).	

Examiner Signature		Date Considered	
--------------------	--	-----------------	--

\*Examiner: Initial if reference was considered, whether or not citation is in conformance with MPEP 809. Draw a line through citation if not in conformance and not considered. Include a copy of this form with next communication to applicant. Notes: If identified, the following is provided: EA = English Abstract, T = Translation, PF = Patent Family.

ALL REFERENCES CONSIDERED EXCEPT WHERE LINED THROUGH. 7/28/00 10680245 TAK

<b>INFORMATION DISCLOSURE STATEMENT BY APPLICANT</b> FORM PTO-1449 (modified)  Sheet 20 of 67	Reexam number	90/010,416
	First Named Inventor	Hutton
	Patent Under Re-Exam	6108704
	Issue Date	2000/08/22
	Group Art Unit	3992
	Examiner Name	KOSOWSKI, ALEXANDER J
	Attorney Docket No.	2655-0188
	Confirmation No.	1061

NON-PATENT REFERENCES			
Examiner Initials*	Cite No.	Non-patent Reference bibliographic information, where available	Notes
	20-1	Dan Keating, Ring! It's Computer Calling Phone By Internet Has Gotten Better, MIAMI HERALD (May 22, 1996).	
	20-2	Daniel C. Swinehart, Telephone Management in the Etherphone System, IEEE (1987).	
	20-3	Daniel H. Craft, Resource Management in a Decentralized System, OPERATING SYSTEMS REVIEW, vol. 17, no. 5 (Association for Computing Machinery, Oct. 1983).	
	20-4	Danny Cohen, IEN 23: On Name, Addresses and Routings (Jan. 23, 1978).	
	20-5	Dave Lindbergh, H.323 Encryption, Document: CNC-96-22 (April 15, 1996).	
	20-6	David D. Clark, RFC 814: Name, Addresses, Ports, and Routes (July 1982).	
	20-7	David Gertler, Hardware and Software Tidbits from CEBIT, SEYBOLD REPORT ON DESKTOP PUBLISHING, vol. 9, no. 8 (Apr. 3, 1995).	

Examiner Signature		Date Considered	
--------------------	--	-----------------	--

\*Examiner: Initial if reference was considered, whether or not citation is in conformance with MPEP 609. Draw a line through citation if not in conformance and not considered. Include a copy of this form with next communication to applicant. Notes: If identified, the following is provided: EA = English Abstract, T = Translation, PF = Patent Family.

ALL REFERENCES CONSIDERED EXCEPT WHERE LINED THROUGH. N2P-18800246 YAK/

<b>INFORMATION DISCLOSURE STATEMENT BY APPLICANT</b> FORM PTO-1449 (modified)  Sheet 21 of 67	Reexam number	90/010,416
	First Named Inventor	Hutton
	Patent Under Re-Exam	6108704
	Issue Date	2000/08/22
	Group Art Unit	3992
	Examiner Name	KOSOWSKI, ALEXANDER J
	Attorney Docket No.	2655-0188
	Confirmation No.	1061

NON-PATENT REFERENCES			
Examiner Initials*	Cite No.	Non-patent Reference bibliographic information, where available	Notes
	21-1	David Hafke, New on the Net – Talk It Up, WINDOWS MAGAZINE, no. 711 (1996).	
	21-2	David Harvey, All the News That's Fit to Speak, NETGUIDE, no. 301 (1996).	
	21-3	David R. Cheriton, et al., A Decentralized Naming Facility (Stanford University, Feb. 1, 1986).	
	21-4	David R. Cheriton, The V Distributed System, COMMUNICATIONS OF THE ACM, vol. 31, no. 3 (Apr. 1988).	
	21-5	David Rapp, I've Got to Get a Message to You, Instant Messaging Started as an MIT Computer-Science Department Project, TECHNOLOGY REVIEW (2002).	
	21-6	DCE 1.0 Security Technology, architectural overview documents, Walter Tuvell, Feb 1997	
	21-7	DCE 1.1 Security Technology, architectural overview documents May 1994	

Examiner Signature		Date Considered	
--------------------	--	-----------------	--

\*Examiner: Initial if reference was considered, whether or not citation is in conformance with MPEP 609. Draw a line through citation if not in conformance and not considered. Include a copy of this form with next communication to applicant. Notes: If identified, the following is provided: EA = English Abstract, T = Translation, PF = Patent Family.

ALL REFERENCES CONSIDERED EXCEPT WHERE LINED THROUGH. N2P-JDS00247 /AK/

<b>INFORMATION DISCLOSURE STATEMENT BY APPLICANT</b> FORM PTO-1449 (modified)	Reexam number	90/010,416
	First Named Inventor	Hutton
	Patent Under Re-Exam	6108704
	Issue Date	2000/08/22
	Group Art Unit	3992
	Examiner Name	KOSOWSKI, ALEXANDER J
	Attorney Docket No.	2655-0188
Sheet 22 of 67	Confirmation No.	1061

NON-PATENT REFERENCES			
Examiner Initials*	Cite No.	Non-patent Reference bibliographic information, where available	Notes
	22-1	DCE RPC Internals and Data Structures (Aug. 1993).	
	22-2	Dean Adams, ed., Security Survival: An indispensable guide to securing your business, X/Open Co. (1996).	
	22-3	Decided H.225.0 (June 19, 1996).	
	22-4	Derek C. Oppen, et al., The Clearinghouse: A Decentralized Agent for Locating Named Objects in a Distributed Environment (Association for Computing Machinery, 1983).	
	22-5	Description of New Zephyr Protocol (undated).	
	22-6	Digiphone Specifications, from Q1.11 of Section 1 of the comp.speech FAQ Home Page (dated Jan. 6, 1997)	
	22-7	Douglas B. Terry, et al., The Berkeley Internet Name Domain Server, USENIX Association Software Tools Users Group, Summer Conference, Salt Lake City, Utah (June 12-15, 1984).	

Examiner Signature		Date Considered	
--------------------	--	-----------------	--

\*Examiner: Initial if reference was considered, whether or not citation is in conformance with MPEP 609. Draw a line through citation if not in conformance and not considered. Include a copy of this form with next communication to applicant. Notes: If identified, the following is provided: EA = English Abstract, T = Translation, PF = Patent Family.

ALL REFERENCES CONSIDERED EXCEPT WHERE LINED THROUGH. /AK/

<b>INFORMATION DISCLOSURE STATEMENT BY APPLICANT</b> FORM PTO-1449 (modified)  Sheet 23 of 67	Reexam number	90/010,416
	First Named Inventor	Hutton
	Patent Under Re-Exam	6108704
	Issue Date	2000/08/22
	Group Art Unit	3992
	Examiner Name	KOSOWSKI, ALEXANDER J
	Attorney Docket No.	2655-0188
	Confirmation No.	1061

NON-PATENT REFERENCES			
Examiner Initials*	Cite No.	Non-patent Reference bibliographic information, where available	Notes
	23-1	Douglas B. Terry, Structure freeName Management for Evolving Distributed Environments, IEEE 6th International Conference on Distributed Computing Systems, Cambridge, Massachusetts (May 19-23, 1986).	
	23-2	Douglas Brian Terry, Distributed Name Servers: Naming and Caching in Large Distributed Computing Environments, Ph.D. Thesis, University of California, Berkeley (Feb. 21, 1985).	
	23-3	Douglas E. Comer, INTERNETWORKING WITH TCP/IP: VOL. 1: PRINCIPLES, PROTOCOLS, AND ARCHITECTURE, 1st ed. (Prentice-Hall, 1988).	
	23-4	Douglas E. Comer, INTERNETWORKING WITH TCP/IP: VOL. 1: PRINCIPLES, PROTOCOLS, AND ARCHITECTURE, 3d ed. (Prentice-Hall, 1995).	
	23-5	Douglas E. Comer, INTERNETWORKING WITH TCP/IP: VOLUME 1: PRINCIPLES, PROTOCOLS, AND ARCHITECTURES, 2d ed. (Prentice-Hall, 1991).	
	23-6	Douglas W. Johnson, Internet-Connected Phone Calls Dial in to Lower Prices, COMPUTERWORLD (Feb. 19, 1996).	
	23-7	Draft ITU-T Recommendation G.723—Dual Rate Speech Coder for Multimedia Communications Transmitting at 5.3 & 6.3 KBIT/S (Oct. 17, 1995).	

Examiner Signature		Date Considered	
--------------------	--	-----------------	--

\*Examiner: Initial if reference was considered, whether or not citation is in conformance with MPEP 609. Draw a line through citation if not in conformance and not considered. Include a copy of this form with next communication to applicant. Notes: If identified, the following is provided: EA = English Abstract, T = Translation, PF = Patent Family.

ALL REFERENCES CONSIDERED EXCEPT WHERE LINED THROUGH. /AK/ N2P-TDS00249

<b>INFORMATION DISCLOSURE STATEMENT BY APPLICANT</b> FORM PTO-1449 (modified)  Sheet 24 of 67	Reexam number	90/010,416
	First Named Inventor	Hutton
	Patent Under Re-Exam	6108704
	Issue Date	2000/08/22
	Group Art Unit	3992
	Examiner Name	KOSOWSKI, ALEXANDER J
	Attorney Docket No.	2855-0188
	Confirmation No.	1061

NON-PATENT REFERENCES			
Examiner Initials*	Cite No.	Non-patent Reference bibliographic information, where available	Notes
	24-1	Draft ITU-T Recommendation H.323 Line Transmission of Non-Telephone Signals: Visual Telephone Systems and Equipment for Local Area Networks Which Provide a Non-Guaranteed Quality of Service, (May 28, 1996).	
	24-2	Draft Recommendation H.323 Visual Telephone Systems and Terminal Equipment for Local Area Networks Which Provide A Non-Guaranteed Quality of Service, Sept. 8, 1995.	
	24-3	Draft Recommendation H.323—Visual Telephone Systems and Equipmt for Local Area Networks Which Provide A Non-Guaranteed Quality of Service (May 28, 1996).	
	24-4	E.D. Sykas, et al., Overview of the CCITT X500 Recommendations Series (Butterworth-Heinemann, 1991).	
	24-5	Electric Magic Company Sales Invoices, February 23, 1995 thru December 3, 1995.	
	24-6	Electric Magic Company, Beta Test License Agreement (dated May 30, 1995)	
	24-7	Elizabeth Feinler, et al., RFC 810: DoD Internet Host Table Specification (Mar. 1, 1982).	

Examiner Signature		Date Considered	
--------------------	--	-----------------	--

\*Examiner: Initial if reference was considered, whether or not citation is in conformance with MPEP 609. Draw a line through citation if not in conformance and not considered. Include a copy of this form with next communication to applicant. Notes: If identified, the following is provided: EA = English Abstract, T = Translation, PF = Patent Family.

ALL REFERENCES CONSIDERED EXCEPT WHERE LINED THROUGH. /AK/ N2P-TDS00250

<b>INFORMATION DISCLOSURE STATEMENT BY APPLICANT</b> FORM PTO-1449 (modified)  Sheet 25 of 87	Reexam number	90/010,416
	First Named Inventor	Hutton
	Patent Under Re-Exam	6108704
	Issue Date	2000/08/22
	Group Art Unit	3992
	Examiner Name	KOSOWSKI, ALEXANDER J
	Attorney Docket No.	2655-0188
Confirmation No.	1061	

NON-PATENT REFERENCES			
Examiner Initials*	Cite No.	Non-patent Reference bibliographic information, where available	Notes
	25-1	Ellen Massmer, PictureTel Brings Video to the Lan Network World (Sept. 4, 1995).	
	25-2	E-mail from Dale Skran to jtoga@ibeam.jf.intel.com, phone numbers for email list (Jan. 6, 1997).	
	25-3	E-mail from Dale Skran to jtoga@ibeam.jf.intel.com, mailing list to enter (Jan. 6, 1997).	
	25-4	E-mail from Ofer Shapiro to Bob Bell, et al., RE: Destination side gateway problem (July 29, 1996).	
	25-5	E-mail from Sakae Okubo to Experts of ITU-T SG16 Q.12/16, Q.13/16 and Q.14/16, Notice of the Q.12-14/16 Sunriver meeting (July 17, 1997).	
	25-6	Email from Sakae Okubo to yves.robin-champigneu10issy.cnet.fr, et al., Working tools of SG16 experts groups (May 8, 1997).	
	25-7	E-mail from Vineet Kumar to h323implementors@mailbag.jf.intel.com Receiver associating a logical channel with a RTP stream (Aug. 5, 1996).	

Examiner Signature		Date Considered	
--------------------	--	-----------------	--

\*Examiner: Initial if reference was considered, whether or not citation is in conformance with MPEP 609. Draw a line through citation if not in conformance and not considered. Include a copy of this form with next communication to applicant. Notes: If identified, the following is provided: EA = English Abstract, T = Translation, PF = Patent Family.

ALL REFERENCES CONSIDERED EXCEPT WHERE LINED THROUGH. 7/27/00 10600251/AK/

<b>INFORMATION DISCLOSURE STATEMENT BY APPLICANT</b> FORM PTO-1449 (modified)  Sheet 26 of 67	Reexam number	90/010,416
	First Named Inventor	Hutton
	Patent Under Re-Exam	6108704
	Issue Date	2000/08/22
	Group Art Unit	3992
	Examiner Name	KOSOWSKI, ALEXANDER J
	Attorney Docket No.	2655-0188
	Confirmation No.	1061

NON-PATENT REFERENCES			
Examiner Initials*	Cite No.	Non-patent Reference bibliographic information, where available	Notes
	26-1	Erdos, Marlena and Pato, Joseph, "Extending the OSF DCE Authorization System to Support Practical Delegation," February 11, 1993	
	26-2	Eric C. Rosen, IEN 183: Logical Addressing (May 1981).	
	26-3	Eric C. Rosen, IEN 188: Issues in Interneting Part 3: Addressing (June 1981).	
	26-4	Etherphone: Collected Papers 1987-1988, Xerox PARC, CSL-89-2 (May 1989).	
	26-5	Eve M. Schooler, Case Study: Multimedia Conference Control in a Packet-Switched Teleconferencing System, JOURNAL OF INTERNETWORKING: RESEARCH AND EXPERIENCE, vol. 4, no. 2 (June 1993).	
	26-6	Eve M. Schooler, et al., An Architecture for Multimedia Connection Management, Proceedings IEEE 4th Comsoc International Workshop on Multimedia Communications, MM '92, Monterey, California (Apr. 1992).	
	26-7	Eve M. Schooler, The Connection Control Protocol: Architecture Overview (Jan. 28, 1992).	

Examiner Signature		Date Considered	
--------------------	--	-----------------	--

\*Examiner: Initial if reference was considered, whether or not citation is in conformance with MPEP 609. Draw a line through citation if not in conformance and not considered. Include a copy of this form with next communication to applicant. Notes: If identified, the following is provided: EA = English Abstract, T = Translation, PF = Patent Family.

ALL REFERENCES CONSIDERED EXCEPT WHERE LINED THROUGH. N2P-10600252 JAK/



<b>INFORMATION DISCLOSURE STATEMENT BY APPLICANT</b> FORM PTO-1449 (modified)  Sheet 27 of 67	Reexam number	90/010,416
	First Named Inventor	Hutton
	Patent Under Re-Exam	6108704
	Issue Date	2000/08/22
	Group Art Unit	3992
	Examiner Name	KOSOWSKI, ALEXANDER J
	Attorney Docket No.	2655-0188
	Confirmation No.	1061

NON-PATENT REFERENCES			
Examiner Initials*	Cite No.	Non-patent Reference bibliographic information, where available	Notes
	27-1	Eve M. Schooler, The Connection Control Protocol: Specification, Version 1.1 (Jan. 29, 1992).	
	27-2	Eve M. Schooler, The Impact of Scaling on Multimedia Connection Architecture, MULTIMEDIA SYSTEMS, vol. 1 (Association for Computing Machinery, 1993).	
	27-3	Exportability of DCE Multi-Crypto Feature by Walter Tuvell, March 5, 1996.	
	27-4	F. Anklesaria, et al., RFC 1436: The Internet Gopher Protocol (A Distributed Document Search and Retrieval Protocol) (Mar. 1993).	
	27-5	FAQ: How Can I Use the Internet as a Telephone, Ver. 0.2 (Apr. 27, 1995)	
	27-6	FAQ: How Can I Use the Internet as a Telephone, Ver. 0.4 (Feb. 23, 1996)	
	27-7	Fax from Ryan Holmquist to Dale Skran (May 30, 1996).	

Examiner Signature		Date Considered	
--------------------	--	-----------------	--

\*Examiner: Initial if reference was considered, whether or not citation is in conformance with MPEP 609. Draw a line through citation if not in conformance and not considered. Include a copy of this form with next communication to applicant. Notes: If identified, the following is provided: EA = English Abstract, T = Translation, PF = Patent Family.

ALL REFERENCES CONSIDERED EXCEPT WHERE LINED THROUGH. /AK/ N2 P- TDS00253

<b>INFORMATION DISCLOSURE STATEMENT BY APPLICANT</b> FORM PTO-1449 (modified)  Sheet 28 of 67	Reexam number	90/010,416
	First Named Inventor	Hutton
	Patent Under Re-Exam	6108704
	Issue Date	2000/08/22
	Group Art Unit	3992
	Examiner Name	KOSOWSKI, ALEXANDER J
	Attorney Docket No.	2655-0188
Confirmation No.	1061	

NON-PATENT REFERENCES			
Examiner Initials*	Cite No.	Non-patent Reference bibliographic information, where available	Notes
	28-1	FLEXIm v3.0 Programmer's Guide, Globetrotter Software, Inc. (Aug. 1994).	
	28-2	Full Duplex Internet Voice Comms Available, NEWSBYTES (Feb. 14, 1995).	
	28-3	Gary A. Thom, H.323: The Multimedia Communications Standard for Local Area Networks, IEEE Communications Magazine (December 2006).	
	28-4	Gilbert Held, The ABCs of IP Addressing, CRC PRESS LLC (2002).	
	28-5	Gligor, et al. "On Inter-realm Authentication in Large Distributed Systems" May 2, 1992	
	28-6	Google Groups "CyberPhone" Search Results, search conducted on November 28, 2007.	
	28-7	Goretsky, Aryeh "PowWow Quick Installation Guide", 1996	

Examiner Signature		Date Considered	
--------------------	--	-----------------	--

\*Examiner: Initial if reference was considered, whether or not citation is in conformance with MPEP 609. Draw a line through citation if not in conformance and not considered. Include a copy of this form with next communication to applicant. Notes: If identified, the following is provided: EA = English Abstract, T = Translation, PF = Patent Family.

ALL REFERENCES CONSIDERED EXCEPT WHERE LINED THROUGH. /AK/

<b>INFORMATION DISCLOSURE STATEMENT BY APPLICANT</b> FORM PTO-1449 (modified)	Reexam number	90/010,416
	First Named Inventor	Hutton
	Patent Under Re-Exam	6108704
	Issue Date	2000/08/22
	Group Art Unit	3992
	Examiner Name	KOSOWSKI, ALEXANDER J
	Attorney Docket No.	2655-0188
Sheet 29 of 67	Confirmation No.	1061

NON-PATENT REFERENCES			
Examiner Initials*	Cite No.	Non-patent Reference bibliographic information, where available	Notes
	29-1	Green, Andrew, NetPhone Tasks and Plans, Email, 2 pages (printed 02/02/95)	
	29-2	Greg Wood. Computer VAR Takes His First Computer Telephony Plunge, COMPUTER TELEPHONY (Sept. 1996).	
	29-3	Gursharan S. Sidu, et al., Inside AppleTalk, 2d ed. (Addison-Wesley Publishing Co., 1990).	
	29-4	H. Schulzrinne, et al., RFC 1889: RTP: A Transport Protocol for Real-Time Applications (Jan. 1996).	
	29-5	Handwritten Notes, Electric Magic Company (dated July 22, 1994 thru August 30, 1995)	
	29-6	How Can I use the Internet as a telephone? from Q1.11 of Section 1 of the comp.speech FAQ Home Page (dated March 19, 1996)	
	29-7	Hussein M. Abdel-Wahab, XTV: A Framework for Sharing X Window Clients in Remote Synchronous Collaboration, IEEE Conference on Communications Software: Communications for Distributed Applications & Systems (Apr. 1991).	

Examiner Signature		Date Considered	
--------------------	--	-----------------	--

\*Examiner: Initial if reference was considered, whether or not citation is in conformance with MPEP 609. Draw a line through citation if not in conformance and not considered. Include a copy of this form with next communication to applicant. Notes: If identified, the following is provided: EA = English Abstract, T = Translation, PF = Patent Family.

ALL REFERENCES CONSIDERED EXCEPT WHERE LINED THROUGH. /AK/ N2-P-TDS00255

<b>INFORMATION DISCLOSURE STATEMENT BY APPLICANT</b> FORM PTO-1449 (modified)  Sheet 30 of 67	Reexam number	90/010,416
	First Named Inventor	Hutton
	Patent Under Re-Exam	6108704
	Issue Date	2000/08/22
	Group Art Unit	3992
	Examiner Name	KOSOWSKI, ALEXANDER J
	Attorney Docket No.	2655-0188
	Confirmation No.	1061

NON-PATENT REFERENCES			
Examiner Initials*	Cite No.	Non-patent Reference bibliographic information, where available	Notes
	30-1	I C. Weider, et al., RFC 1727: A Vision of an Integrated Information Service (Dec. 1994).	
	30-2	Inder Gopal, et al., Directories for Networks with Casually Connected Users (IEEE, 1988).	
	30-3	Information Technology – Database Language SQL (Proposed revised text of DIS 9075), DIGITAL EQUIPMENT CORP. (July 1992).	
	30-4	InterFACE from Hjjinx Specifications, from Q1.11 of Section 1 of the comp.speech FAQ Home Page (dated March 19, 1996)	
	30-5	Internet Phone from VocalTec Specifications, from Q1.11 of Section 1 of the comp.speech FAQ Home Page (dated March 19, 1996)	
	30-6	Internet PHONE Release 4, Users Manual, VocalTech 1996.	
	30-7	Internet Telephone Companies Racing to Market, VOICE TECHNOLOGY & SERVICES NEWS, vol. 14 no. 20 (Oct. 3, 1995).	

Examiner Signature		Date Considered	
--------------------	--	-----------------	--

\*Examiner: Initial if reference was considered, whether or not citation is in conformance with MPEP 609. Draw a line through citation if not in conformance and not considered. Include a copy of this form with next communication to applicant. Notes: If identified, the following is provided: EA = English Abstract, T = Translation, PF = Patent Family.

ALL REFERENCES CONSIDERED EXCEPT WHERE LINED THROUGH. 7AK/ N2P-IDS00256

<b>INFORMATION DISCLOSURE STATEMENT BY APPLICANT</b> FORM PTO-1449 (modified)	Reexam number	90/010,416
	First Named Inventor	Hutton
	Patent Under Re-Exam	6108704
	Issue Date	2000/08/22
	Group Art Unit	3992
	Examiner Name	KOSOWSKI, ALEXANDER J
	Attorney Docket No.	2655-0188
Sheet 31 of 67	Confirmation No.	1061

NON-PATENT REFERENCES			
Examiner Initials*	Cite No.	Non-patent Reference bibliographic information, where available	Notes
	31-1	INTRODUCTION TO OSF DCE (Prentice-Hall, Inc., 1992).	
	31-2	ITU-T Recommendation X.500—Information technology – Open Systems Interconnection – The Directory: Overview of concepts, models and services (Aug. 1997).	
	31-3	ITU-T Recommendation X.501—Information technology – Open Systems Interconnection – The Directory: Models (Aug. 1997).	
	31-4	J. Oikarinen, et al., RFC 1459: Internet Relay Chat Protocol (May 1993).	
	31-5	J. Pato, Hierarchical Trust Relationships for Inter-Cell Authentication, Slides, (July 7 1992).	
	31-6	J. Pato, RFC 7.0: Hierarchical Trust Relationships for Inter-Cell Authentication (July 1992).	
	31-7	J. Postel, et al., RFC 959: File Transfer Protocol (FTP) (Oct. 1985).	

Examiner Signature		Date Considered	
--------------------	--	-----------------	--

\*Examiner: Initial if reference was considered, whether or not citation is in conformance with MPEP 609. Draw a line through citation if not in conformance and not considered. Include a copy of this form with next communication to applicant. Notes: If identified, the following is provided: EA = English Abstract, T = Translation, PF = Patent Family.

ALL REFERENCES CONSIDERED EXCEPT WHERE LINED THROUGH. N2P TDS00257 /AK/

<b>INFORMATION DISCLOSURE STATEMENT BY APPLICANT</b> FORM PTO-1449 (modified)  Sheet 32 of 67	Reexam number	90/010,416
	First Named Inventor	Hutton
	Patent Under Re-Exam	6108704
	Issue Date	2000/08/22
	Group Art Unit	3992
	Examiner Name	KOSOWSKI, ALEXANDER J
	Attorney Docket No.	2655-0188
	Confirmation No.	1061

NON-PATENT REFERENCES			
Examiner Initials*	Cite No.	Non-patent Reference bibliographic information, where available	Notes
	32-1	J. Postel, RFC 765: File Transfer Protocol (June 1980).	
	32-2	J. Postel, RFC 925: Multi-LAN Address Resolution (Oct. 1984).	
	32-3	J. Saltzer, RFC 1498: On the Naming and Binding of Network Destinations (Aug. 1993).	
	32-4	Jack Rickard, Voice Over Internet – the Internet Phone, BOARDWATCH MAGAZINE, vol. 9, no. 4 (Apr. 1995).	
	32-5	James M. Bloom, et al., Experiences Implementing BIND, A Distributed Name Server for the DARPA Internet (June 9-13, 1986).	
	32-6	James Martin, et al., TCP/IP NETWORKING: ARCHITECTURE, ADMINISTRATION, AND PROGRAMMING (Prentice Hall, 1994).	
	32-7	James Staten, NetPhone 1.2 Calls the Web, MACWEEK, vol. 9 no. 27 (July 10, 1995).	

Examiner Signature		Date Considered	
--------------------	--	-----------------	--

\*Examiner: Initial if reference was considered, whether or not citation is in conformance with MPEP 809. Draw a line through citation if not in conformance and not considered. Include a copy of this form with next communication to applicant. Notes: If identified, the following is provided: EA = English Abstract, T = Translation, PF = Patent Family.

ALL REFERENCES CONSIDERED EXCEPT WHERE LINED THROUGH. /AK/ N2P-IDS00258

<b>INFORMATION DISCLOSURE STATEMENT BY APPLICANT</b> FORM PTO-1449 (modified)  Sheet 33 of 67	Reexam number	90/010,416
	First Named Inventor	Hutton
	Patent Under Re-Exam	6108704
	Issue Date	2000/08/22
	Group Art Unit	3992
	Examiner Name	KOSOWSKI, ALEXANDER J
	Attorney Docket No.	2655-0188
	Confirmation No.	1061

NON-PATENT REFERENCES			
Examiner Initials*	Cite No.	Non-patent Reference bibliographic information, where available	Notes
	33-1	Jennifer G. Steiner, et al., Kerberos: An Authentication Service for Open Network Systems, USENIX Winter Conference, Dallas, Texas (Feb. 9-12, 1988).	
	33-2	Joe Maloney, DCE: Focus on Security, the Internet and the Future (printed 4/25/2002, date unknown)	
	33-3	Joe Pato, et al., Distributed Computing Environment (DCE) Design of the Security Services and Facilities (Aug. 10, 1992).	
	33-4	Joe Pato, Extending the DCE Authorization Model to Support Practical Delegation—Extended Summary (July 7 1992).	
	33-5	Joe Pato, RFC 3.0: Extending the DCE Authorization Model to Support Practical Delegation—Extended Summary (June 1992).	
	33-6	Joe Pato, RFC 6.0: A Generic Interface for Extended Registry Attributes (June 1992).	
	33-7	John A. Pershing, Jr., et al., IEN 162: Transport, Addressing, and Routing in the Wideband Net (Oct. 1980).	

Examiner Signature		Date Considered	
--------------------	--	-----------------	--

\*Examiner: Initial if reference was considered, whether or not citation is in conformance with MPEP 609. Draw a line through citation if not in conformance and not considered. Include a copy of this form with next communication to applicant. Notes: If identified, the following is provided: EA = English Abstract, T = Translation, PF = Patent Family.

ALL REFERENCES CONSIDERED EXCEPT WHERE LINED THROUGH. N2P-JDS00259 TAK

<b>INFORMATION DISCLOSURE STATEMENT BY APPLICANT</b> FORM PTO-1449 (modified)	Reexam number	90/010,416
	First Named Inventor	Hutton
	Patent Under Re-Exam	6108704
	Issue Date	2000/08/22
	Group Art Unit	3992
	Examiner Name	KOSOWSKI, ALEXANDER J
	Attorney Docket No.	2655-0188
Sheet 34 of 67	Confirmation No.	1061

NON-PATENT REFERENCES			
Examiner Initials*	Cite No.	Non-patent Reference bibliographic information, where available	Notes
	34-1	John F. Shoch, IEN 19: Inter-Network Naming, Addressing, and Routing (Jan. 1978).	
	34-2	John Ioannidis, et al., IP-based Protocols for Mobile Internetworking, COLUMBIA UNIV., DEPT. OF COMPUTER SCIENCE (1991).	
	34-3	John R. Pickens, et al., RFC 756: The NIC Name Server - A Datagram Based Information Utility (July 1979).	
	34-4	John T. Kohl, The Zephyr Notification Service, First International Athena Technical Conference (Apr. 11, 1991).	
	34-5	John Veizades, et al., Service Location Protocol, INTERNET DRAFT (May 2, 1995).	
	34-6	Jon Hill, et al., Pow Wow, PC MAGAZINE, vol. 15 no. 17 (Oct. 8, 1996).	
	34-7	Jon Hill, TeleVox, PC MAGAZINE, vol. 15 no. 17 (Oct. 8, 1996).	

Examiner Signature		Date Considered	
--------------------	--	-----------------	--

\*Examiner: Initial if reference was considered, whether or not citation is in conformance with MPEP 609. Draw a line through citation if not in conformance and not considered. Include a copy of this form with next communication to applicant. Notes: If identified, the following is provided: EA = English Abstract, T = Translation, PF = Patent Family.

ALL REFERENCES CONSIDERED EXCEPT WHERE LINED THROUGH. <sup>72 P. 10600260</sup> /AK/



<b>INFORMATION DISCLOSURE STATEMENT BY APPLICANT</b> FORM PTO-1449 (modified)  Sheet 35 of 67	Reexam number	90/010,416
	First Named Inventor	Hutton
	Patent Under Re-Exam	6108704
	Issue Date	2000/08/22
	Group Art Unit	3992
	Examiner Name	KOSOWSKI, ALEXANDER J
	Attorney Docket No.	2655-0188
	Confirmation No.	1061

NON-PATENT REFERENCES			
Examiner Initials*	Cite No.	Non-patent Reference bibliographic information, where available	Notes
	35-1	Jon Livesey, Inter-process Communication and Naming in the Mininet System, Eighteenth Annual IEEE Computer Society International Conference, San Francisco, California (1979).	
	35-2	Jon Postel, RFC 921: Domain Name System Implementation Schedule — Revised (Oct. 1984).	
	35-3	José M. Bernabeu-Auban, et al., Optimizing a Generalized Polling Protocol for Resource Finding over a Multiple Access Channel, COMPUTER NETWORKS AND ISDN SYSTEMS 27 (1995).	
	35-4	Josina M. Arfman, et al., Project Athena: Supporting Distributed Computing at MIT, IBM SYSTEMS JOURNAL (1992).	
	35-5	K. Harrenstien, et al., RFC 811: Hostname Server (Oct. 1985).	
	35-6	K. Harrenstien, et al., RFC 952: DoD Internet Host Table Specification (Oct. 1985).	
	35-7	K. Harrenstien, RFC 742: Name/Finger (Dec. 30, 1977).	

Examiner Signature		Date Considered	
--------------------	--	-----------------	--

\*Examiner: Initial if reference was considered, whether or not citation is in conformance with MPEP 609. Draw a line through citation if not in conformance and not considered. Include a copy of this form with next communication to applicant. Notes: If identified, the following is provided: EA = English Abstract, T = Translation, PF = Patent Family.

ALL REFERENCES CONSIDERED EXCEPT WHERE LINED THROUGH. N2P-10600261 TAK/

<b>INFORMATION DISCLOSURE STATEMENT BY APPLICANT</b> FORM PTO-1449 (modified)  Sheet 36 of 67	Reexam number	90/010,416
	First Named Inventor	Hutton
	Patent Under Re-Exam	6108704
	Issue Date	2000/08/22
	Group Art Unit	3992
	Examiner Name	KOSOWSKI, ALEXANDER J
	Attorney Docket No.	2655-0188
	Confirmation No.	1061

NON-PATENT REFERENCES			
Examiner Initials*	Cite No.	Non-patent Reference bibliographic information, where available	Notes
	36-1	Kahane, Opher et al., "Call Management Agent System Specification" VoIP Forum Technical Committee Contribution (dated Aug. 15, 1996)	
	36-2	Karl Auerbach, et al., RFC 1001: Protocol Standard for a NetBIOS Service on a TCP/UDP Transport: Concepts and Methods (Mar. 1987).	
	36-3	Keith A. Lantz, et al., Towards a Universal Directory Service, 4th PODC Conference Proceedings (Association for Computing Machinery, 1985).	
	36-4	Ken Harrenstien, et al., RFC 811: Hostnames Server (Mar. 1, 1982).	
	36-5	Ken Harrenstien, RFC 811: Hostnames Server (Mar. 1, 1982).	
	36-6	Ken Harrenstien, RFC 812: Nicname/Whois (Mar. 1, 1982).	
	36-7	Kenneth Hart, Startups, industry mainstays add to Internet phone menu, COMMUNICATIONSWEEK INT'L (Nov. 27, 1995).	

Examiner Signature		Date Considered	
--------------------	--	-----------------	--

\*Examiner: Initial if reference was considered, whether or not citation is in conformance with MPEP 609. Draw a line through citation if not in conformance and not considered. Include a copy of this form with next communication to applicant. Notes: If identified, the following is provided: EA = English Abstract, T = Translation, PF = Patent Family.

ALL REFERENCES CONSIDERED EXCEPT WHERE LINED THROUGH. TAKI N2P-IDS00262

<b>INFORMATION DISCLOSURE STATEMENT BY APPLICANT</b> FORM PTO-1449 (modified)	Reexam number	90/010,416
	First Named Inventor	Hutton
	Patent Under Re-Exam	6108704
	Issue Date	2000/08/22
	Group Art Unit	3992
	Examiner Name	KOSOWSKI, ALEXANDER J
	Attorney Docket No.	2655-0188
Sheet 37 of 67	Confirmation No.	1061

NON-PATENT REFERENCES			
Examiner Initials*	Cite No.	Non-patent Reference bibliographic information, where available	Notes
	37-1	Klaus Zeuge, et al., The Client-to-Client Protocol (CTCP) (published no later than Aug. 12, 1994).	
	37-2	Kohl, John T., "Zephyr Installation and Operation Guide", DRAFT - November 20, 1989	
	37-3	Koster, Steven "The Phone Companies Worst Nightmare" Hotwired, April 1995.	
	37-4	L. Landweber, et al., Architecture of the CSNET Name Server (Association for Computing Machinery, 1983).	
	37-5	L. Peter Deutsch, RFC 606: Host Names On-Line (Dec. 1973).	
	37-6	Larry L. Peterson, A Yellow-Pages Service for a Local-Area Network (Association for Computing Machinery, 1988).	
	37-7	Larry L. Peterson, The Profile Naming Service, ACM TRANSACTIONS ON COMPUTER SYSTEMS, vol. 6, No. 4, (Nov. 1988).	

Examiner Signature		Date Considered	
--------------------	--	-----------------	--

\*Examiner: Initial if reference was considered, whether or not citation is in conformance with MPEP 609. Draw a line through citation if not in conformance and not considered. Include a copy of this form with next communication to applicant. Notes: If identified, the following is provided: EA = English Abstract, T = Translation, PF = Patent Family.

ALL REFERENCES CONSIDERED EXCEPT WHERE LINED THROUGH. N2P-TDS00263 JAK

<b>INFORMATION DISCLOSURE STATEMENT BY APPLICANT</b> FORM PTO-1449 (modified)  Sheet 38 of 67	Reexam number	90/010,416
	First Named Inventor	Hutton
	Patent Under Re-Exam	6108704
	Issue Date	2000/08/22
	Group Art Unit	3992
	Examiner Name	KOSOWSKI, ALEXANDER J
	Attorney Docket No.	2655-0188
	Confirmation No.	1061

NON-PATENT REFERENCES			
Examiner Initials*	Cite No.	Non-patent Reference bibliographic information, where available	Notes
	38-1	Lisa Zahn, et al., Network Computing Architecture, Prentice Hall (1990).	
	38-2	List of Names from a DCE Meeting; attendees from DISA, OSF, DEC, Mitre, HP, Open Market and others (undated)	
	38-3	Listserve postings by Jon Postel, Dynamic Updated Proposal, dated Sept. 1 and 9, 1993.	
	38-4	Listserve postings by Susan Thomson, DNS Dynamic Updates, dated July 14, 1994.	
	38-5	Lon Wagner, New Software Lets Users Talk for Cheap, VIRGINIAN-PILOT (Mar. 26, 1995).	
	38-6	M. Bever, et al., Distributed Systems, OSF DCE, and Beyond (1993).	
	38-7	M.D. Kudlick, RFC 608: Host Names On-Line (Jan. 10, 1974).	

Examiner Signature		Date Considered	
--------------------	--	-----------------	--

\*Examiner: Initial if reference was considered, whether or not citation is in conformance with MPEP 609. Draw a line through citation if not in conformance and not considered. Include a copy of this form with next communication to applicant. Notes: If identified, the following is provided: EA = English Abstract, T = Translation, PF = Patent Family.

ALL REFERENCES CONSIDERED EXCEPT WHERE LINED THROUGH. 7AK/ N2P-IDS00264

<b>INFORMATION DISCLOSURE STATEMENT BY APPLICANT</b> FORM PTO-1449 (modified)  Sheet 39 of 67	Reexam number	90/010,416
	First Named Inventor	Hutton
	Patent Under Re-Exam	6108704
	Issue Date	2000/08/22
	Group Art Unit	3992
	Examiner Name	KOSOWSKI, ALEXANDER J
	Attorney Docket No.	2655-0188
	Confirmation No.	1061

NON-PATENT REFERENCES			
Examiner Initials*	Cite No.	Non-patent Reference bibliographic information, where available	Notes
	39-1	Making the Most of IP Telephony, VocalTec Annual Report 1997	
	39-2	Mark Crispin, RFC 752: A Universal Host Table (Jan. 2, 1979).	
	39-3	Mark Reid, Ptell Call Control Procedure in H.323 (June 16, 1995).	
	39-4	Markus Sohlenkamp & Greg Chwelos, Integrating Communication, Cooperation, and Awareness: The DIVA Virtual Office Environment (1994).	
	39-5	Mic Bowman, et al., Unifers: An Attribute-based Name Server, SOFTWARE PRACTICE AND EXPERIENCE, vol. 20(4) (Apr. 1990).	
	39-6	Michael D. Schroeder, et al., Experience with Grapevine: The Growth of a Distributed System, ACM Transactions on Computer Systems (Feb. 1984).	
	39-7	Michael D. Schroeder, et al., Experience with Grapevine: The Growth of a Distributed System, ACM TRANSACTIONS ON COMPUTER SYSTEMS, vol. 2, No. 1 (Feb. 1984).	

Examiner Signature		Date Considered	
--------------------	--	-----------------	--

\*Examiner: Initial if reference was considered, whether or not citation is in conformance with MPEP 609. Draw a line through citation if not in conformance and not considered. Include a copy of this form with next communication to applicant. Notes: If identified, the following is provided: EA = English Abstract, T = Translation, PF = Patent Family.

ALL REFERENCES CONSIDERED EXCEPT WHERE LINED THROUGH. 7AK/ N2P-JDS00265

<b>INFORMATION DISCLOSURE STATEMENT BY APPLICANT</b> FORM PTO-1449 (modified)	Reexam number	90/010,416
	First Named Inventor	Hutton
	Patent Under Re-Exam	6108704
	Issue Date	2000/08/22
	Group Art Unit	3992
	Examiner Name	KOSOWSKI, ALEXANDER J
	Attorney Docket No.	2655-0188
Sheet 40 of 67	Confirmation No.	1061

NON-PATENT REFERENCES			
Examiner Initials*	Cite No.	Non-patent Reference bibliographic information, where available	Notes
	40-1	Michael F. Schwartz, et al., A Comparison of Internet Resource Discovery Approaches, COMPUTING SYSTEMS (Aug. 1992).	
	40-2	Michael F. Schwartz, et al., A Name Service for Evolving, Heterogeneous Systems, ACM (1987).	
	40-3	Michael J. Bibeau, A Formative Evaluation of CU-SeeMe, Masters Thesis, Virginia Polytechnic Institute and State University (Feb. 20, 1995) (including CU-SeeMe Users Manual by same author published Jan. 1995).	
	40-4	Michelle Slataffa, Hold the Phone! You Can Call Long Distance on a Computer For Pennies, But it has its Drawbacks, NEWSDAY (Mar. 14, 1995).	
	40-5	Mike Kong, et al., Network Computing System Reference Manual, Prentice Hall (1990).	
	40-6	Mike Kudlick, et al., RFC 627: ASCII Text File of Hostnames (Mar. 25, 1974).	
	40-7	Mitch Wagner, Phone Home Cheaply Over the I-Way, OPEN SYSTEMS TODAY (Feb. 20, 1995).	

Examiner Signature		Date Considered	
--------------------	--	-----------------	--

\*Examiner: Initial if reference was considered, whether or not citation is in conformance with MPEP 609. Draw a line through citation if not in conformance and not considered. Include a copy of this form with next communication to applicant. Notes: If identified, the following is provided: EA = English Abstract, T = Translation, PF = Patent Family.

ALL REFERENCES CONSIDERED EXCEPT WHERE LINED THROUGH. N3-P-TDS00266 JAK/

<b>INFORMATION DISCLOSURE STATEMENT BY APPLICANT</b> FORM PTO-1449 (modified)  Sheet 41 of 67	Reexam number	90/010,416
	First Named Inventor	Hutton
	Patent Under Re-Exam	6108704
	Issue Date	2000/08/22
	Group Art Unit	3992
	Examiner Name	KOSOWSKI, ALEXANDER J
	Attorney Docket No.	2655-0188
	Confirmation No.	1061

NON-PATENT REFERENCES			
Examiner Initials*	Cite No.	Non-patent Reference bibliographic information, where available	Notes
	41-1	MITRE Fort Meade Site DCE Meeting Sign In-Sheet 1/16/1995	
	41-2	Mostafa H. Ammar, et al., Using Hint Tables to Locate Resources in Distributed Systems (IEEE, 1988).	
	41-3	Motorola Micro TAC International 5000 Series Manual (undated)	
	41-4	Motorola Micro TAC International 7000 Series (dated 5/94)	
	41-5	Motorola Micro TAC International 7500 Series (undated)	
	41-6	Motorola Micro TAC International 8000 Series (undated)	
	41-7	Nate Zelnick, Chat on the Web: An Overview, INTERACTIVE CONTENT, vol. 2, no. 17 (Sept. 1995).	

Examiner Signature		Date Considered	
--------------------	--	-----------------	--

\*Examiner: Initial if reference was considered, whether or not citation is in conformance with MPEP 609. Draw a line through citation if not in conformance and not considered. Include a copy of this form with next communication to applicant. Notes: if identified, the following is provided: EA = English Abstract, T = Translation, PF = Patent Family.

ALL REFERENCES CONSIDERED EXCEPT WHERE LINED THROUGH. /AK/ N2P-TDS00267

<b>INFORMATION DISCLOSURE STATEMENT BY APPLICANT</b> FORM PTO-1449 (modified)  Sheet 42 of 67	Reexam number	90/010,416
	First Named Inventor	Hutton
	Patent Under Re-Exam	6108704
	Issue Date	2000/08/22
	Group Art Unit	3992
	Examiner Name	KOSOWSKI, ALEXANDER J
	Attorney Docket No.	2655-0188
	Confirmation No.	1061

NON-PATENT REFERENCES			
Examiner Initials*	Cite No.	Non-patent Reference bibliographic information, where available	Notes
	42-1	Nautilus: Secure Computer Telephony, from Q1.11 of Section 1 of the comp.speech FAQ Home Page (dated Aug. 7, 1996)	
	42-2	NetPhone 1.0 User Manual, Electric Magic Company (document includes date 94-12-31)	
	42-3	NetPhone 1.1 User Manual, Electric Magic Company (document includes date 1995-02-16)	
	42-4	NetPhone Demo Instructions, Electric Magic Company, 1994.	
	42-5	NetPhone Development Plan (undated)	
	42-6	NetPhone Development Plan v0.1 (undated)	
	42-7	NetPhone Digital User Manual, Electric Magic Company, 95-02-26.	

Examiner Signature		Date Considered	
--------------------	--	-----------------	--

\*Examiner: Initial if reference was considered, whether or not citation is in conformance with MPEP 609. Draw a line through citation if not in conformance and not considered. Include a copy of this form with next communication to applicant. Notes: If identified, the following is provided: EA = English Abstract, T = Translation, PF = Patent Family.

ALL REFERENCES CONSIDERED EXCEPT WHERE LINED THROUGH. /AK/ N3P-TDS00268



<b>INFORMATION DISCLOSURE STATEMENT BY APPLICANT</b> FORM PTO-1449 (modified)	Reexam number	90/010,416
	First Named Inventor	Hutton
	Patent Under Re-Exam	6108704
	Issue Date	2000/08/22
	Group Art Unit	3992
	Examiner Name	KOSOWSKI, ALEXANDER J
	Attorney Docket No.	2655-0188
Sheet 43 of 67	Confirmation No.	1061

NON-PATENT REFERENCES			
Examiner Initials*	Cite No.	Non-patent Reference bibliographic information, where available	Notes
	43-1	NetPhone Digital User Manual, Electric Magic Company, 95-03-12.	
	43-2	NetPhone Information Manual, Electric Magic Company, May 30, 1995.	
	43-3	NetPhone Testing Notes, September 28, 1994.	
	43-4	Netphone, Change Notes, December 6.	
	43-5	Nigel Hinds, et al., Name Space Models for Locating Services, IBM Canada Laboratory Technical Report 74.074 (1991).	
	43-6	Norbert Leser, Towards a Worldwide Distributed File System: The OSF DCE File System as an example (Sept. 27, 1990).	
	43-7	Open Group, Cambridge Information (June 23, 1997).	

Examiner Signature		Date Considered	
--------------------	--	-----------------	--

\*Examiner: Initial if reference was considered, whether or not citation is in conformance with MPEP 609. Draw a line through citation if not in conformance and not considered. Include a copy of this form with next communication to applicant. Notes: If identified, the following is provided: EA = English Abstract, T = Translation, PF = Patent Family.

ALL REFERENCES CONSIDERED EXCEPT WHERE LINED THROUGH. /AK/ N3-P-TDS00268

<b>INFORMATION DISCLOSURE STATEMENT BY APPLICANT</b> FORM PTO-1449 (modified)  Sheet 44 of 67	Reexam number	90/010,416
	First Named Inventor	Hutton
	Patent Under Re-Exam	6108704
	Issue Date	2000/08/22
	Group Art Unit	3992
	Examiner Name	KOSOWSKI, ALEXANDER J
	Attorney Docket No.	2655-0188
	Confirmation No.	1061

NON-PATENT REFERENCES			
Examiner Initials*	Cite No.	Non-patent Reference bibliographic information, where available	Notes
	44-1	Open Software Foundation Security Sig (March 19, 1996).	
	44-2	Open Software Foundation, AES/Distributed Computing RPC Volume, PTR Prentice Hall (1994).	
	44-3	Open Software Foundation, DCE Internals Course, Instructor Guide Vol. 1 (1992).	
	44-4	Open Software Foundation, DCE Internals Course, Instructor Guide Vol. 2 (1992).	
	44-5	Open Software Foundation, Industry Analysis of DCE (May 15, 1990).	
	44-6	Open Software Foundation, Introduction to OSF DCE , Prentice Hall (1992).	
	44-7	Open Software Foundation, Open Line Magazine (May/June 1990).	

Examiner Signature		Date Considered	
--------------------	--	-----------------	--

\*Examiner: Initial if reference was considered, whether or not citation is in conformance with MPEP 609. Draw a line through citation if not in conformance and not considered. Include a copy of this form with next communication to applicant. Notes: If identified, the following is provided: EA = English Abstract, T = Translation, PF = Patent Family.

ALL REFERENCES CONSIDERED EXCEPT WHERE LINED THROUGH. NXP-IDS00270 /AK/

<b>INFORMATION DISCLOSURE STATEMENT BY APPLICANT</b> FORM PTO-1449 (modified)  Sheet 45 of 67	Reexam number	90/010,416
	First Named Inventor	Hutton
	Patent Under Re-Exam	6108704
	Issue Date	2000/08/22
	Group Art Unit	3992
	Examiner Name	KOSOWSKI, ALEXANDER J
	Attorney Docket No.	2655-0188
	Confirmation No.	1061

NON-PATENT REFERENCES			
Examiner Initials*	Cite No.	Non-patent Reference bibliographic information, where available	Notes
	45-1	Open Software Foundation, OSF DCE Administration Guide Core Components, PTR Prentice Hall (1993).	
	45-2	Open Software Foundation, OSF DCE Administration Guide—Extended Services, PTR Prentice Hall (1993).	
	45-3	Open Software Foundation, OSF DCE Administration Guide—Introduction, PTR Prentice Hall (1993).	
	45-4	Open Software Foundation, OSF DCE Administration Reference, PTR Prentice Hall (1993).	
	45-5	Open Software Foundation, OSF DCE Application Development Guide, PTR Prentice Hall (1993).	
	45-6	Open Software Foundation, OSF DCE Application Development Reference, PTR Prentice Hall (1993).	
	45-7	Open Software Foundation, OSF DCE User's Guide and Reference, PTR Prentice Hall (1993).	

Examiner Signature		Date Considered	
--------------------	--	-----------------	--

\*Examiner: Initial if reference was considered, whether or not citation is in conformance with MPEP 609. Draw a line through citation if not in conformance and not considered. Include a copy of this form with next communication to applicant. Notes: If identified, the following is provided: EA = English Abstract, T = Translation, PF = Patent Family.

ALL REFERENCES CONSIDERED EXCEPT WHERE LINED THROUGH. N2P-IPDS00271-1/AK/

<b>INFORMATION DISCLOSURE STATEMENT BY APPLICANT</b> FORM PTO-1449 (modified)	Reexam number	90/010,416
	First Named Inventor	Hutton
	Patent Under Re-Exam	6108704
	Issue Date	2000/08/22
	Group Art Unit	3992
	Examiner Name	KOŚOWSKI, ALEXANDER J
	Attorney Docket No.	2655-0188
Sheet 46 of 67	Confirmation No.	1061

NON-PATENT REFERENCES			
Examiner Initials*	Cite No.	Non-patent Reference bibliographic information, where available	Notes
	46-1	OSF DCE USER'S GUIDE AND REFERENCE (Prentice-Hall, Inc., 1993).	
	46-2	P. Deutsch, et al., RFC 1835: Architecture of the Whois++ Service (Aug. 1995).	
	46-3	P. Faltstrom, et al., RFC 1914: How to Interact with a Whois++ Mesh (Feb. 1996).	
	46-4	P. Mockapetris, RFC 882: Domain Names - Concepts and Facilities (Nov. 1983).	
	46-5	P. Mockapetris, RFC 883: Domain Names - Implementation and Specification (Nov. 1983).	
	46-6	P. Venkat Rangan, et al., Software Architecture for Integration of Video Services in the Etherphone System, IEEE JOURNAL ON SELECTED AREAS IN COMMUNICATIONS, vol. 9, No. 9 (Dec. 1991).	
	46-7	P.M. Gopal, et al., Consistent Resource Registration, IBM TECHNICAL DISCLOSURE BULLETIN, vol. 37, no. 9 (Sept. 1994).	

Examiner Signature		Date Considered	
--------------------	--	-----------------	--

\*Examiner: Initial if reference was considered, whether or not citation is in conformance with MPEP 609. Draw a line through citation if not in conformance and not considered. Include a copy of this form with next communication to applicant. Notes: If identified, the following is provided: EA = English Abstract, T = Translation, PF = Patent Family.

ALL REFERENCES CONSIDERED EXCEPT WHERE LINED THROUGH. N2P-18600372 AK/

<b>INFORMATION DISCLOSURE STATEMENT BY APPLICANT</b> FORM PTO-1449 (modified)  Sheet 47 of 67	Reexam number	90/010,416
	First Named Inventor	Hutton
	Patent Under Re-Exam	6108704
	Issue Date	2000/08/22
	Group Art Unit	3992
	Examiner Name	KOSOWSKI, ALEXANDER J
	Attorney Docket No.	2655-0188
	Confirmation No.	1061

NON-PATENT REFERENCES			
Examiner Initials*	Cite No.	Non-patent Reference bibliographic information, where available	Notes
	47-1	Part 1 of Open Software Foundation, X/Open Preliminary Specification—X/Open DCE: Authentication and Security Services (March 1996).	
	47-2	Part 2 chapter 2 thru 5 of Open Software Foundation, X/Open Preliminary Specification—X/Open DCE: Authentication and Security Services (March 1996).	
	47-3	Part 2 chapter 6 thru 13 of Open Software Foundation, X/Open Preliminary Specification—X/Open DCE: Authentication and Security Services (March 1996).	
	47-4	Part 3 and Part 4 of Open Software Foundation, X/Open Preliminary Specification—X/Open DCE: Authentication and Security Services (March 1996).	
	47-5	Pato, Joseph N., A Generic Interface for Extended Registry Attributes, July 7, 1992.	
	47-6	Paul Albitz, et al., DNS AND BIND IN A NUTSHELL (O'Reilly & Associates, 1992).	
	47-7	Paul Mockapetris, RFC 1034: Domain Name - Concepts and Facilities (Nov. 1987).	

Examiner Signature		Date Considered	
--------------------	--	-----------------	--

\*Examiner: Initial if reference was considered, whether or not citation is in conformance with MPEP 609. Draw a line through citation if not in conformance and not considered. Include a copy of this form with next communication to applicant. Notes: If identified, the following is provided: EA = English Abstract, T = Translation, PF = Patent Family.

ALL REFERENCES CONSIDERED EXCEPT WHERE LINED THROUGH. TAKI N2P 18500273

<b>INFORMATION DISCLOSURE STATEMENT BY APPLICANT</b> FORM PTO-1449 (modified)  Sheet 48 of 67	Reexam number	90/010,416
	First Named Inventor	Hutton
	Patent Under Re-Exam	6108704
	Issue Date	2000/08/22
	Group Art Unit	3992
	Examiner Name	KOSOWSKI, ALEXANDER J
	Attorney Docket No.	2655-0188
	Confirmation No.	1061

NON-PATENT REFERENCES			
Examiner Initials*	Cite No.	Non-patent Reference bibliographic information, where available	Notes
	48-1	Paul Mockapetris, RFC 1035: Domain Name – Implementation and Specification (Nov. 1987).	
	48-2	Paul V. Mockapetris, et al., Development of the Domain Name Server, COMPUTER COMMUNICATION REVIEW, vol. 18, no. 4 (Aug. 1988).	
	48-3	Paul V. Mockapetris, et al., Development of the Domain Name System, COMPUTER COMMUNICATION REVIEW (Aug. 1988).	
	48-4	Phoning By Web, SAN FRANCISCO CHRONICLE (Mar. 12, 1996).	
	48-5	PictureTel Corp., 10-K405/A (filed Jan. 13, 1998).	
	48-6	PictureTel LiveLan (printed 12/3/2007)	
	48-7	Ping Lin's Email to mackey, Comments on DCE 1.1 Delegation RFC, July 2, 1992.	

Examiner Signature		Date Considered	
--------------------	--	-----------------	--

\*Examiner: Initial if reference was considered, whether or not citation is in conformance with MPEP 609. Draw a line through citation if not in conformance and not considered. Include a copy of this form with next communication to applicant. Notes: If identified, the following is provided: EA = English Abstract, T = Translation, PF = Patent Family.

ALL REFERENCES CONSIDERED EXCEPT WHERE LINED THROUGH. N2 P. TDS00274 AKI

<b>INFORMATION DISCLOSURE STATEMENT BY APPLICANT</b> FORM PTO-1449 (modified)	Reexam number	90/010,416
	First Named Inventor	Hutton
	Patent Under Re-Exam	6108704
	Issue Date	2000/08/22
	Group Art Unit	3992
	Examiner Name	KOSOWSKI, ALEXANDER J
	Attorney Docket No.	2655-0188
Sheet 49 of 67	Confirmation No.	1061

NON-PATENT REFERENCES			
Examiner Initials*	Cite No.	Non-patent Reference bibliographic information, where available	Notes
	49-1	Polle T. Zellweger, et al., An Overview of the Etherphone System and its Applications (IEEE, 1988).	
	49-2	Postel, RFC 791: Internet Protocol: Darpa Internet Program Protocol Specification (Sept. 1981).	
	49-3	Postel, RFC 793: Transmission Control Protocol: Darpa Internet Program Protocol Specification (Sept. 1981).	
	49-4	PowWow For Microsoft Windows User's Guide, Version 1.4B, Documentation by Token White Man (dated 1995)	
	49-5	PowWow For Microsoft Windows User's Guide, Version 1.5, Documentation by Aryeh Goretsky (dated 1995)	
	49-6	PowWow For Microsoft Windows User's Guide, Version 1.6 beta 2, Documentation by Aryeh Goretsky (dated 1995)	
	49-7	PowWow For Microsoft Windows User's Guide, Version 1.6 beta, Documentation by Aryeh Goretsky (dated 1995)	

Examiner Signature		Date Considered	
--------------------	--	-----------------	--

\*Examiner: Initial if reference was considered, whether or not citation is in conformance with MPEP 609. Draw a line through citation if not in conformance and not considered. Include a copy of this form with next communication to applicant. Notes: If identified, the following is provided: EA = English Abstract, T = Translation, PF = Patent Family.

ALL REFERENCES CONSIDERED EXCEPT WHERE LINED THROUGH. N3 P. TDS00275 /AK/

<b>INFORMATION DISCLOSURE STATEMENT BY APPLICANT</b> FORM PTO-1449 (modified)  Sheet 50 of 67	Reexam number	90/010,416
	First Named Inventor	Hutton
	Patent Under Re-Exam	6108704
	Issue Date	2000/08/22
	Group Art Unit	3992
	Examiner Name	KOSOWSKI, ALEXANDER J
	Attorney Docket No.	2655-0188
	Confirmation No.	1061

NON-PATENT REFERENCES			
Examiner Initials*	Cite No.	Non-patent Reference bibliographic information, where available	Notes
	50-1	PowWow For Microsoft Windows User's Guide, Version 1.7 beta 1, Documentation by Aryeh Goretsky (dated 1995)	
	50-2	PowWow For Microsoft Windows User's Guide, Version 1.7 beta 2, Documentation by Aryeh Goretsky (dated 1995)	
	50-3	PowWow For Microsoft Windows User's Guide, Version 1.7 beta 3, Documentation by Aryeh Goretsky (dated 1995)	
	50-4	PowWow For Microsoft Windows User's Guide, Version 1.7 beta 4, Documentation by Aryeh Goretsky (dated 1995)	
	50-5	PowWow For Microsoft Windows User's Guide, Version 2.0 beta 1, Documentation by Aryeh Goretsky (dated 1995, 1996)	
	50-6	PowWow For Microsoft Windows User's Guide, Version 2.1, Documentation by Aryeh Goretsky (dated 1995, 1996)	
	50-7	PowWow For Microsoft Windows User's Guide, Version 2.2 beta 1, Documentation by Aryeh Goretsky (dated 1995, 1996)	

Examiner Signature		Date Considered	
--------------------	--	-----------------	--

\*Examiner: Initial if reference was considered, whether or not citation is in conformance with MPEP 609. Draw a line through citation if not in conformance and not considered. Include a copy of this form with next communication to applicant. Notes: If identified, the following is provided: EA = English Abstract, T = Translation, PF = Patent Family.

ALL REFERENCES CONSIDERED EXCEPT WHERE LINED THROUGH. 9AK/ N2P-58509276



<b>INFORMATION DISCLOSURE STATEMENT BY APPLICANT</b> FORM PTO-1449 (modified)  Sheet 51 of 67	Reexam number	90/010,416
	First Named Inventor	Hutton
	Patent Under Re-Exam	6108704
	Issue Date	2000/08/22
	Group Art Unit	3992
	Examiner Name	KOSOWSKI, ALEXANDER J
	Attorney Docket No.	2655-0188
	Confirmation No.	1061

NON-PATENT REFERENCES			
Examiner Initials*	Cite No.	Non-patent Reference bibliographic information, where available	Notes
	51-1	PowWow For Microsoft Windows User's Guide, Version 2.2 beta 2, Documentation by Aryeh Goretsky (dated 1995, 1996)	
	51-2	PowWow For Microsoft Windows User's Guide, Version 2.3, Documentation by Aryeh Goretsky (dated 1995, 1996)	
	51-3	PowWow For Microsoft Windows User's Guide, Version 2.31, Documentation by Aryeh Goretsky (dated 1995, 1996)	
	51-4	PowWow For Microsoft Windows User's Guide, Version 2.32, Documentation by Aryeh Goretsky (dated 1995, 1996)	
	51-5	PowWow For Microsoft Windows User's Guide, Version 3.0 beta 3, Documentation by Aryeh Goretsky (dated 1995, 1996)	
	51-6	PowWow User Local Server Version 1.0 beta 2 Release Notes (Dated June 18, 1996)	
	51-7	PowWow User Location Server for Microsoft Windows NT and 95 Version 1.0 beta 2 Installation Guide, by Goretsky, Aryeh (dated 1996)	

Examiner Signature		Date Considered	
--------------------	--	-----------------	--

\*Examiner: Initial if reference was considered, whether or not citation is in conformance with MPEP 609. Draw a line through citation if not in conformance and not considered. Include a copy of this form with next communication to applicant. Notes: If identified, the following is provided: EA = English Abstract, T = Translation, PF = Patent Family.

ALL REFERENCES CONSIDERED EXCEPT WHERE LINED THROUGH. N2P 18600277AK

<b>INFORMATION DISCLOSURE STATEMENT BY APPLICANT</b> FORM PTO-1449 (modified)  Sheet 52 of 67	Reexam number	90/010,416
	First Named Inventor	Hutton
	Patent Under Re-Exam	6108704
	Issue Date	2000/08/22
	Group Art Unit	3992
	Examiner Name	KOSOWSKI, ALEXANDER J
	Attorney Docket No.	2655-0188
	Confirmation No.	1061

NON-PATENT REFERENCES			
Examiner Initials*	Cite No.	Non-patent Reference bibliographic information, where available	Notes
	52-1	PowWow Version Release Notes (covering versions 1.4b to 2.32) (dated June 26, 1996)	
	52-2	PowWow32 Release Notes (PowWow Versions 3.0 beta 3 and 3.0 beta 2) (dated November 21, 1996)	
	52-3	Prospectus for VocalTech Ordinary Shares, February 6, 1996	
	52-4	Questions and Comments: DCE RFC 6.0 "A Generic Interface for Extended Registry Attributes" Commentary by Bob Blakley, July 6, 1992	
	52-5	R. Braden, RFC 1644 T/TCP -- TCP Extensions for Transactions Functional Specifications (July 1994).	
	52-6	R. Droms, RFC 1531: Dynamic Host Configuration Protocol (Oct. 1993).	
	52-7	R. Droms, RFC 1541: Dynamic Host Configuration Protocol (Oct. 1993).	

Examiner Signature		Date Considered	
--------------------	--	-----------------	--

\*Examiner: Initial if reference was considered, whether or not citation is in conformance with MPEP 609. Draw a line through citation if not in conformance and not considered. Include a copy of this form with next communication to applicant. Notes: If identified, the following is provided: EA = English Abstract, T = Translation, PF = Patent Family.

ALL REFERENCES CONSIDERED EXCEPT WHERE LINED THROUGH. PAK/ 2655-0188

<b>INFORMATION DISCLOSURE STATEMENT BY APPLICANT</b> FORM PTO-1449 (modified)  Sheet 53 of 67	Reexam number	90/010,416
	First Named Inventor	Hutton
	Patent Under Re-Exam	6108704
	Issue Date	2000/08/22
	Group Art Unit	3992
	Examiner Name	KOSOWSKI, ALEXANDER J
	Attorney Docket No.	2655-0188
	Confirmation No.	1061

NON-PATENT REFERENCES			
Examiner Initials*	Cite No.	Non-patent Reference bibliographic information, where available	Notes
	53-1	R.C. Summers, Local-Area Distributed Systems, IBM SYSTEMS JOURNAL, vol. 28, No. 2 (1989).	
	53-2	Raj Pandya, Emerging Mobile and Personal Communication Systems, IEEE COMMUNICATIONS MAGAZINE (June 1995).	
	53-3	RFC 1001: Protocol Standard for a NetBIOS Service on a TCP/UDP Transport: Concepts and Methods, Mar. 1987.	
	53-4	RFC 1057: RPC Remote Procedure Call Protocol Specification Version 2, June 1988	
	53-5	Richard Karpinski, Internet Phones Battle for the Market, INTERACTIVE AGE, no. 212 (1995).	
	53-6	Richard Karpinski, Upgrading Internet Phone - VocalTec Offers Full-Duplex Version, Eliminating Voice Delays, INTERACTIVE AGE, no. 216 (1995).	
	53-7	Richard T. Snodgrass, Developing Time-Oriented Database Applications in SQL, MORGAN KAUFMANN PUBLISHERS (2000).	

Examiner Signature		Date Considered	
--------------------	--	-----------------	--

\*Examiner: Initial if reference was considered, whether or not citation is in conformance with MPEP 609. Draw a line through citation if not in conformance and not considered. Include a copy of this form with next communication to applicant. Notes: If identified, the following is provided: EA = English Abstract, T = Translation, PF = Patent Family.

ALL REFERENCES CONSIDERED EXCEPT WHERE LINED THROUGH. N27-18600279 JAK/

<b>INFORMATION DISCLOSURE STATEMENT BY APPLICANT</b> FORM PTO-1449 (modified)  Sheet 54 of 67	Reexam number	90/010,416
	First Named Inventor	Hutton
	Patent Under Re-Exam	6108704
	Issue Date	2000/08/22
	Group Art Unit	3992
	Examiner Name	KOSOWSKI, ALEXANDER J
	Attorney Docket No.	2655-0188
	Confirmation No.	1061

NON-PATENT REFERENCES			
Examiner Initials*	Cite No.	Non-patent Reference bibliographic information, where available	Notes
	54-1	Rivka Tadjer, Internet Communications Solutions: How Well Do They Work?, COMPUTER SHOPPER, vol. 15, no. 6 (June 1995).	
	54-2	Rivka Tadjer, Internet Phones to Upstage Videoconferencing Products? Talk is Cheaper with Local Worldwide Dialing, COMPUTER SHOPPER, vol. 15, no. 5 (May 1995).	
	54-3	Rob Walters, COMPUTER TELEPHONE INTEGRATION (Artech House, 1993).	
	54-4	Robert E. Kahn, et al., Advances in Packet Radio Technology, Proceedings Of The IEEE (Nov. 1978).	
	54-5	Robert Gurwitz, et al., IEN 212: IP — Local Area Network Addressing Issues (Sept. 1982).	
	54-6	Robert J. Williams, User Location Service (Feb. 1996).	
	54-7	Robert Joseph Fowler, Decentralized Object Finding Using Forwarding Addresses, Ph.D. Thesis, University of Washington (Dec. 1985).	

Examiner Signature		Date Considered	
--------------------	--	-----------------	--

\*Examiner: Initial if reference was considered, whether or not citation is in conformance with MPEP 609. Draw a line through citation if not in conformance and not considered. Include a copy of this form with next communication to applicant. Notes: If identified, the following is provided: EA = English Abstract, T = Translation, PF = Patent Family.

ALL REFERENCES CONSIDERED EXCEPT WHERE LINED THROUGH. /AK/

<b>INFORMATION DISCLOSURE STATEMENT BY APPLICANT</b> FORM PTO-1449 (modified)  Sheet 55 of 67	Reexam number	90/010,416
	First Named Inventor	Hutton
	Patent Under Re-Exam	6108704
	Issue Date	2000/08/22
	Group Art Unit	3992
	Examiner Name	KOSOWSKI, ALEXANDER J
	Attorney Docket No.	2655-0188
	Confirmation No.	1061

NON-PATENT REFERENCES			
Examiner Initials*	Cite No.	Non-patent Reference bibliographic information, where available	Notes
	55-1	Robert Richardson, Internet Phone, LAN MAGAZINE, vol. 10, no. 7 (July 1995).	
	55-2	Robert Richardson, Pow Wow, Anyone? A Web Chat That Works, LAN MAGAZINE, vol. 10 no. 9 (Sept. 1995).	
	55-3	Robert S. French, et al., The Zephyr Programmer's Manual, Rev. 2.1 (May 5, 1989).	
	55-4	Rosen, Nick "Internet Opens Line on Cheap Global Phone Calls" The Guardian, February 10, 1995, A1.	
	55-5	S. Waldbusser, et al., RFC 1742: AppleTalk Management Information Base II (Jan. 1995).	
	55-6	S.R. Ahuja, et al., The Rapport Multimedia Conferencing System, ACM (1988).	
	55-7	Sakae Okubo, et al., Draft ITU-T Recommendation H.245—Line Transmission of Non-Telephone Signals: Control Protocol for Multimedia Communication (Nov. 14, 1995).	

Examiner Signature		Date Considered	
--------------------	--	-----------------	--

\*Examiner: Initial if reference was considered, whether or not citation is in conformance with MPEP 609. Draw a line through citation if not in conformance and not considered. Include a copy of this form with next communication to applicant. Notes: If identified, the following is provided: EA = English Abstract, T = Translation, PF = Patent Family.

ALL REFERENCES CONSIDERED EXCEPT WHERE LINED THROUGH. N2P-1860281 JAK/

<b>INFORMATION DISCLOSURE STATEMENT BY APPLICANT</b> FORM PTO-1449 (modified)  Sheet 56 of 67	Reexam number	90/010,416
	First Named Inventor	Hutton
	Patent Under Re-Exam	6108704
	Issue Date	2000/08/22
	Group Art Unit	3992
	Examiner Name	KOSOWSKI, ALEXANDER J
	Attorney Docket No.	2655-0188
	Confirmation No.	1061

NON-PATENT REFERENCES			
Examiner Initials*	Cite No.	Non-patent Reference bibliographic information, where available	Notes
	56-1	Sakae Okubo, et al., ITU-T Recommendation H.245—Line Transmission of Non-Telephone Signals: Control Protocol for Multimedia Communication (May 20, 1996).	
	56-2	Sakae Okubo, et al., Line Transmission of Non-Telephone Signals: Control Protocol for Multimedia Communication, Recommendation H245 (May 20, 1996).	
	56-3	Sakae Okubo, et al., ITU-T Standardization of Audiovisual Communication Systems in ATM and LAN Environments (April 17, 1996).	
	56-4	Sape J. Mullender, et al., Distributed Match-Making for Processes in Computer Networks (Association for Computing Machinery, 1985).	
	56-5	Sape Mullender, ed., Distributed Systems, ACM Press (1992).	
	56-6	Sapwater, E. "Webbed", 2 pages (undated)	
	56-7	Saruchi Mohan, Internet Phone Accepting Calls, COMPUTERWORLD (Feb. 27, 1995).	

Examiner Signature		Date Considered	
--------------------	--	-----------------	--

\*Examiner: Initial if reference was considered, whether or not citation is in conformance with MPEP 809. Draw a line through citation if not in conformance and not considered. Include a copy of this form with next communication to applicant. Notes: If identified, the following is provided: EA = English Abstract, T = Translation, PF = Patent Family.

ALL REFERENCES CONSIDERED EXCEPT WHERE LINED THROUGH. 7AK/ N2P 38600282

<b>INFORMATION DISCLOSURE STATEMENT BY APPLICANT</b> FORM PTO-1449 (modified)  Sheet 57 of 67	Reexam number	90/010,416
	First Named Inventor	Hutton
	Patent Under Re-Exam	6108704
	Issue Date	2000/08/22
	Group Art Unit	3992
	Examiner Name	KOSOWSKI, ALEXANDER J
	Attorney Docket No.	2655-0188
	Confirmation No.	1061

NON-PATENT REFERENCES			
Examiner Initials*	Cite No.	Non-patent Reference bibliographic information, where available	Notes
	57-1	Savetz, Kevin "Net as Phone" Internet World, July 1995.	
	57-2	Schill, et al., ed., IFIP/IEEE International Conference on Distributed Platforms—Client/Server and Beyond: DCE, CORBA, ODP & Advanced Distribution Applications, Technical University Bergakademie Freiburg (1996).	
	57-3	Schulzrinne, Service Conference Invitation Protocol, INTERNET DRAFT (Feb. 22, 1996).	
	57-4	Scott Kahn, Leave Your Message on My PC After the Beep, PC WEEK (Oct. 3, 1994).	
	57-5	Sharon Fisher, Fruits of Athena - Academic Projects Like Athen Have Given the World Its First Inking of What Computer Interoperability is All About, COMMUNICATIONS WEEK (1992).	
	57-6	Snell, Jason "Foiling Ma Bell" MacUser, July, 1995.	
	57-7	Speak Freely, from Q1.11 of Section 1 of the comp.speech FAQ Home Page (dated March 19, 1996)	

Examiner Signature		Date Considered	
--------------------	--	-----------------	--

\*Examiner: Initial if reference was considered, whether or not citation is in conformance with MPEP 609. Draw a line through citation if not in conformance and not considered. Include a copy of this form with next communication to applicant. Notes: If identified, the following is provided: EA = English Abstract, T = Translation, PF = Patent Family.

ALL REFERENCES CONSIDERED EXCEPT WHERE LINED THROUGH. N2P-1850283/PAK/

<b>INFORMATION DISCLOSURE STATEMENT BY APPLICANT</b> FORM PTO-1449 (modified)  Sheet 58 of 67	Reexam number	90/010,416
	First Named Inventor	Hutton
	Patent Under Re-Exam	6108704
	Issue Date	2000/08/22
	Group Art Unit	3992
	Examiner Name	KOSOWSKI, ALEXANDER J
	Attorney Docket No.	2655-0188
	Confirmation No.	1061

NON-PATENT REFERENCES			
Examiner Initials*	Cite No.	Non-patent Reference bibliographic information, where available	Notes
	58-1	Staff Phone List (July 1, 1997).	
	58-2	Steinberg, Bob "Will Politics Interfere With The Global Internet?" Mashpee Enterprise, April 28, 1995.	
	58-3	Stephen A. Uhler, PhoneStation, Moving the Telephone onto the Virtual Desktop, 1993 Winter Usenix, San Diego, California (Jan. 25-29, 1993).	
	58-4	Steve Hamm, The Merry Pranksters, PC WEEK, vol. 12 no. 34 (Aug. 28, 1995).	
	58-5	Stuart Harris, THE IRC SURVIVAL GUIDE: TALK TO THE WORLD WITH INTERNET RELAY CHAT (Addison-Wesley, Feb. 1995).	
	58-6	Sun Microsystems, Inc., RFC 1050: RPC: Remote Procedure Call Protocol Specification Version 2 (June 1988).	
	58-7	Surfers Can Drop Phones, ELECTRONICS TIMES (Feb. 16, 1995).	

Examiner Signature		Date Considered	
--------------------	--	-----------------	--

\*Examiner: Initial if reference was considered, whether or not citation is in conformance with MPEP 609. Draw a line through citation if not in conformance and not considered. Include a copy of this form with next communication to applicant. Notes: If identified, the following is provided: EA = English Abstract, T = Translation, PF = Patent Family.

ALL REFERENCES CONSIDERED EXCEPT WHERE LINED THROUGH. N2P-10600284 AKI



<b>INFORMATION DISCLOSURE STATEMENT BY APPLICANT</b> FORM PTO-1449 (modified)  Sheet 59 of 67	Reexam number	90/010,416
	First Named Inventor	Hutton
	Patent Under Re-Exam	6108704
	Issue Date	2000/08/22
	Group Art Unit	3992
	Examiner Name	KOSOWSKI, ALEXANDER J
	Attorney Docket No.	2655-0188
	Confirmation No.	1061

NON-PATENT REFERENCES			
Examiner Initials*	Cite No.	Non-patent Reference bibliographic information, where available	Notes
	59-1	Susan Thomson, et al., DNS Dynamic Updates, IETF DNSIND WORKING GROUP (July 1994).	
	59-2	T. Berners-Lee, et al., RFC 1738: Uniform Resource Locators (URL) (Dec. 1994).	
	59-3	Tamila Baron, Hearing Voices on the Net, COMMUNICATIONS WEEK (Feb. 20, 1995).	
	59-4	Tamila Baron, VocalTec, Motorola Team Up for Internet Phone and Modem Bundle, COMMUNICATIONS WEEK, no. 549 (1995).	
	59-5	Ted Anderson's Email to dmackey re DCE 1.1 Delegation Proposal for Review, June 23, 1992.	
	59-6	Ted Anderson's Email to pato, Re: RFC 7.0 (really glp92), July 21, 1992.	
	59-7	The 4.BSD-Lite distribution announcement, COMPUTER SYSTEMS RESEARCH GROUP (Mar. 1, 1994), and related newsgroup postings, dated Apr. 21-22, 1994.	

Examiner Signature		Date Considered	
--------------------	--	-----------------	--

\*Examiner: Initial if reference was considered, whether or not citation is in conformance with MPEP 809. Draw a line through citation if not in conformance and not considered. Include a copy of this form with next communication to applicant. Notes: If identified, the following is provided: EA = English Abstract, T = Translation, PF = Patent Family.

ALL REFERENCES CONSIDERED EXCEPT WHERE LINED THROUGH. N2P-10601285 JAK/

<b>INFORMATION DISCLOSURE STATEMENT BY APPLICANT</b> FORM PTO-1449 (modified)  Sheet 60 of 67	Reexam number	90/010,416
	First Named Inventor	Hutton
	Patent Under Re-Exam	6108704
	Issue Date	2000/08/22
	Group Art Unit	3992
	Examiner Name	KOSOWSKI, ALEXANDER J
	Attorney Docket No.	2655-0188
	Confirmation No.	1061

NON-PATENT REFERENCES			
Examiner Initials*	Cite No.	Non-patent Reference bibliographic information, where available	Notes
	60-1	The Electric Magic Company, Business Plan, Version 0.1 draft, April 17, 1995.	
	60-2	The Open Group Organization Chart (Oct. 1997).	
	60-3	The Open Group Organization Chart October 1996 (Confidential)	
	60-4	The OSF Distributed Computing Environment: Building on International Standards, OSF White Paper (Apr. 1992).	
	60-5	The VocalChat User's Guide, September 28, 1993.	
	60-6	Thomas Maresca, The Internet Phone Company?, CONSUMER INFORMATION APPLIANCE, no. 55 (Feb. 1995).	
	60-7	TIMOP: DCE Time Operations Sample Application. (undated)	

Examiner Signature		Date Considered	
--------------------	--	-----------------	--

\*Examiner: Initial if reference was considered, whether or not citation is in conformance with MPEP 609. Draw a line through citation if not in conformance and not considered. Include a copy of this form with next communication to applicant. Notes: If identified, the following is provided: EA = English Abstract, T = Translation, PF = Patent Family.

ALL REFERENCES CONSIDERED EXCEPT WHERE LINED THROUGH. N2P-10500286 YAK/

<b>INFORMATION DISCLOSURE STATEMENT BY APPLICANT</b> FORM PTO-1449 (modified)  Sheet 61 of 67	Reexam number	90/010,416
	First Named Inventor	Hutton
	Patent Under Re-Exam	6108704
	Issue Date	2000/08/22
	Group Art Unit	3992
	Examiner Name	KOSOWSKI, ALEXANDER J
	Attorney Docket No.	2655-0188
	Confirmation No.	1061

NON-PATENT REFERENCES			
Examiner Initials*	Cite No.	Non-patent Reference bibliographic information, where available	Notes
	61-1	Timothy J. O'Malley, Analysis of the Zephyr Communication Paradigm, Bachelor of Science in Computer Science and Engineering, Thesis, Massachusetts Institute of Technology (May 1993).	
	61-2	Todd Copilevitz, Heard on the Internet, THE STAR-LEDGER (March 7, 1995).	
	61-3	Tom Lyons, Network Computing System Tutorial, Prentice Hall (1991).	
	61-4	Tony Pompili, VocalTec: The Internet Phone Number?, PC MAGAZINE (May 16, 1995).	
	61-5	Translation of Japanese Patent Application No. Sho 63[1988]-131637 (Original dated June 3, 1988)	
	61-6	Transparencies: Walter Tuvell, DCE 1.0 Security Technology—Detailed Architectural Overview (Feb. 1997).	
	61-7	V. Jacobson, et al., RFC 1185: TCP Extension for High-Speed Paths (Oct. 1990).	

Examiner Signature		Date Considered	
--------------------	--	-----------------	--

\*Examiner: Initial if reference was considered, whether or not citation is in conformance with MPEP 609. Draw a line through citation if not in conformance and not considered. Include a copy of this form with next communication to applicant. Notes: If identified, the following is provided: EA = English Abstract, T = Translation, PF = Patent Family.

ALL REFERENCES CONSIDERED EXCEPT WHERE LINED THROUGH. 7AK/

<b>INFORMATION DISCLOSURE STATEMENT BY APPLICANT</b> FORM PTO-1449 (modified)	Reexam number	90/010,416
	First Named Inventor	Hutton
	Patent Under Re-Exam	6108704
	Issue Date	2000/08/22
	Group Art Unit	3992
	Examiner Name	KOSOWSKI, ALEXANDER J
	Attorney Docket No.	2655-0188
Sheet 62 of 67	Confirmation No.	1061

NON-PATENT REFERENCES			
Examiner Initials*	Cite No.	Non-patent Reference bibliographic information, where available	Notes
	62-1	VocalChat 1.01 Network Information (undated)	
	62-2	VocalChat Early Beta Release 1.02B Information (undated)	
	62-3	VocalChat GTI 2.12 Beta Retrieval Instructions and Information (undated)	
	62-4	VocalChat Version 1.0, README.TXT, November, 1993.	
	62-5	VocalChat Version 1.01, README.TXT, March, 1994.	
	62-6	VocalChat Version 2.01 and Wan 2.01, README.TXT. May 1994.	
	62-7	VocalTec Annual Report, 1996	

Examiner Signature		Date Considered	
--------------------	--	-----------------	--

\*Examiner: Initial if reference was considered, whether or not citation is in conformance with MPEP 609. Draw a line through citation if not in conformance and not considered. Include a copy of this form with next communication to applicant. Notes: If identified, the following is provided: EA = English Abstract, T = Translation, PF = Patent Family.

ALL REFERENCES CONSIDERED EXCEPT WHERE LINED THROUGH. 9AK/

<b>INFORMATION DISCLOSURE STATEMENT BY APPLICANT</b> FORM PTO-1449 (modified)	Reexam number	90/010,416
	First Named Inventor	Hutton
	Patent Under Re-Exam	6108704
	Issue Date	2000/08/22
	Group Art Unit	3992
	Examiner Name	KOSOWSKI, ALEXANDER J
	Attorney Docket No.	2655-0188
Sheet 63 of 67	Confirmation No.	1061

NON-PATENT REFERENCES			
Examiner Initials*	Cite No.	Non-patent Reference bibliographic information, where available	Notes
	63-1	VocalTec Cross-Reference Sheet, Pursuant to Item 501 of Reg. S-K (dated January, 1996)	
	63-2	VocalTec Internet Phone Information Sheet, 2 pages. (dated June 1995)	
	63-3	VocalTec Internet Phone Version 3.0 Build 17, README.TXT, August 11, 1995.	
	63-4	VocalTec Internet Phone Version 3.2 Build 21, README.TXT, March 25, 1996.	
	63-5	VocalTec SEC 20-F Filing, 1996	
	63-6	VocalTec SEC F-1 Filing, December 22, 1995	
	63-7	VocalTec SEC F-1 Filing, January 5, 1996	

Examiner Signature		Date Considered	
--------------------	--	-----------------	--

\*Examiner: Initial if reference was considered, whether or not citation is in conformance with MPEP 609. Draw a line through citation if not in conformance and not considered. Include a copy of this form with next communication to applicant. Notes: If identified, the following is provided: EA = English Abstract, T = Translation, PF = Patent Family.

ALL REFERENCES CONSIDERED EXCEPT WHERE LINED THROUGH. 92P-10603-89AK/

<b>INFORMATION DISCLOSURE STATEMENT BY APPLICANT</b> FORM PTO-1449 (modified).  Sheet 64 of 67	Reexam number	90/010,416
	First Named Inventor	Hutton
	Patent Under Re-Exam	6108704
	Issue Date	2000/08/22
	Group Art Unit	3992
	Examiner Name	KOSOWSKI, ALEXANDER J
	Attorney Docket No.	2655-0188
Confirmation No.	1061	

NON-PATENT REFERENCES			
Examiner Initials*	Cite No.	Non-patent Reference bibliographic information, where available	Notes
	64-1	Voice Over the Internet, BOARDWATCH MAGAZINE, vol. IX, no. 1 (Jan. 1995).	
	64-2	W. David Albrecht, CPA Firms on the World Wide Web, OHIO CPA JOURNAL (June 1996).	
	64-3	W. Simpson, RFC 1661: The Point-to-Point Protocol (PPP) (July 1994).	
	64-4	W. Yeong, et al., RFC 1777. Lightweight Directory Access Protocol (Mar. 1995).	
	64-5	Walt and maclcp's ip addresses and code (undated)	
	64-6	Walter Tuvell, DCE 1.0 Security Technology- Detailed Architectural Overview (Feb. 1997).	
	64-7	Walter Tuvell, DCE 1.0 Security Technology Detailed Architectural Overview, Draft (Feb. 1997).	

Examiner Signature		Date Considered	
--------------------	--	-----------------	--

\*Examiner: Initial if reference was considered, whether or not citation is in conformance with MPEP 609. Draw a line through citation if not in conformance and not considered. Include a copy of this form with next communication to applicant. Notes: If identified, the following is provided: EA = English Abstract, T = Translation, PF = Patent Family.

ALL REFERENCES CONSIDERED EXCEPT WHERE LINED THROUGH. PAK/

<b>INFORMATION DISCLOSURE STATEMENT BY APPLICANT</b> FORM PTO-1449 (modified)  Sheet 65 of 67	Reexam number	90/010,416
	First Named Inventor	Hutton
	Patent Under Re-Exam	6108704
	Issue Date	2000/08/22
	Group Art Unit	3992
	Examiner Name	KOSOWSKI, ALEXANDER J
	Attorney Docket No.	2655-0188
Confirmation No.	1061	

NON-PATENT REFERENCES			
Examiner Initials*	Cite No.	Non-patent Reference bibliographic information, where available	Notes
	65-1	Walter Tuvell, DCE 1.0 Security Technology: Detailed Architectural Overview (Feb. 1997).	
	65-2	Walter Tuvell, DCE 1.0 Security Technology: Detailed Architectural Overview (May 1994).	
	65-3	Walter Tuvell, DCE Multi-Crypto Support—Proposal to NSA for Funding and Exportability of Multiple Cryptographic Mechanisms in OSF's Distributed Computing Environment (Sept. 12, 1995).	
	65-4	Walter Tuvell, Distribution & The Infobahn (1996).	
	65-5	Walter Tuvell, Exportability of DCE Multi-Crypto Feature (March 5, 1996).	
	65-6	Walter Tuvell, RFC 98.0: Challenges Concerning Public-Key in DCE (Dec. 1996).	
	65-7	Walter Tuvell, System V/ONC Comparison to AIX/NCS (Oct. 3, 1988).	

Examiner Signature		Date Considered	
--------------------	--	-----------------	--

\*Examiner: Initial if reference was considered, whether or not citation is in conformance with MPEP 609. Draw a line through citation if not in conformance and not considered. Include a copy of this form with next communication to applicant. Notes: If identified, the following is provided: EA = English Abstract, T = Translation, PF = Patent Family.

ALL REFERENCES CONSIDERED EXCEPT WHERE LINED OUT BY EXAMINER

<b>INFORMATION DISCLOSURE STATEMENT BY APPLICANT</b> FORM PTO-1449 (modified)	Reexam number	90/010,416
	First Named Inventor	Hutton
	Patent Under Re-Exam	6108704
	Issue Date	2000/08/22
	Group Art Unit	3992
	Examiner Name	KOSOWSKI, ALEXANDER J
	Attorney Docket No.	2655-0188
Sheet 66 of 67	Confirmation No.	1061

NON-PATENT REFERENCES			
Examiner Initials*	Cite No.	Non-patent Reference bibliographic information, where available	Notes
	66-1	Walter Tuvell, The DCE Dance: Application Development in 29 Easy Steps (Sept. 1991).	
	66-2	Walter Tuvell, The OSF Distributed Computing Environment (DE). (undated)	
	66-3	Web Phone, from Q1.11 of Section 1 of the comp.speech FAQ Home Page (dated March 19, 1996)	
	66-4	WebSTAR Technical Reference (formerly MacHTTP), StarNine Technologies, 1995.	
	66-5	Wei Hu, DCE Security Programming, O'Reilly & Associates (July 1995).	
	66-6	Welch, Nathalie "Vendors Ring in New Telephony Options" MacWeek, April 10, 1995, pg 18.	
	66-7	Wendy Woods, Newsbytes Daily Summary, NEWSBYTES (June 10, 1994).	

Examiner Signature		Date Considered	
--------------------	--	-----------------	--

\*Examiner: Initial if reference was considered, whether or not citation is in conformance with MPEP 609. Draw a line through citation if not in conformance and not considered. Include a copy of this form with next communication to applicant. Notes: If identified, the following is provided: EA = English Abstract, T = Translation, PF = Patent Family.

ALL REFERENCES CONSIDERED EXCEPT WHERE LINED THROUGH. 7AK/ N2P-1060192



<b>INFORMATION DISCLOSURE STATEMENT BY APPLICANT</b> FORM PTO-1449 (modified)  Sheet 67 of 67	Reexam number	90/010,416
	First Named Inventor	Hutton
	Patent Under Re-Exam	6108704
	Issue Date	2000/08/22
	Group Art Unit	3992
	Examiner Name	KOSOWSKI, ALEXANDER J
	Attorney Docket No.	2655-0188
	Confirmation No.	1061

NON-PATENT REFERENCES			
Examiner Initials*	Cite No.	Non-patent Reference bibliographic information, where available	Notes
	67-1	William M. Bulkeley, On-line: Hello, world. Audible Chats on the Internet, WALL STREET JOURNAL (Feb. 10, 1995).	
	67-2	Winther, Mark. "The World Wide Web Phones Home: Internet Telephony Market Assessment, 1996-1999", International Data Corporation White Paper (dated 1996)	
	67-3	Xerox System Integration Standard Clearinghouse Protocol (April 1984).	
	67-4	Yakov Rekhter, et al., Dynamic Updates in the Domain Name System (DNS):Architecture and Mechanism, Internet-Draft, DNSIND Working Group (July 15, 1994).	
	67-5		
	67-6		
	67-7		

Examiner Signature	/Alexander Kosowski/	Date Considered	07/19/2010
--------------------	----------------------	-----------------	------------

\*Examiner: Initial if reference was considered, whether or not citation is in conformance with MPEP 609. Draw a line through citation if not in conformance and not considered. Include a copy of this form with next communication to applicant. Notes: If identified, the following is provided: EA = English Abstract, T = Translation, PF = Patent Family.

ALL REFERENCES CONSIDERED EXCEPT WHERE LINED THROUGH. N2P-10508293 AKI

<b>Search Notes</b>  	<b>Application/Control No.</b> 90010416	<b>Applicant(s)/Patent Under Reexamination</b> 6108704
	<b>Examiner</b> ALEXANDER J KOSOWSKI	<b>Art Unit</b> 3992

<b>SEARCHED</b>			
<b>Class</b>	<b>Subclass</b>	<b>Date</b>	<b>Examiner</b>

<b>SEARCH NOTES</b>		
<b>Search Notes</b>	<b>Date</b>	<b>Examiner</b>
Reviewed proposed prior art and prosecution history	5/4/10	AJK
Reviewed proposed prior art	7/14/10	AJK

<b>INTERFERENCE SEARCH</b>			
<b>Class</b>	<b>Subclass</b>	<b>Date</b>	<b>Examiner</b>

--	--

<b>Reexamination</b> 	Application/Control No. 90010416	Applicant(s)/Patent Under Reexamination 6108704
	Certificate Date	Certificate Number CI

Requester Correspondence Address:	<input type="checkbox"/> Patent Owner	<input checked="" type="checkbox"/> Third Party
<p>Blakely Sokoloff Taylor &amp; Zafman LLP 1279 Oakmead Parkway Sunnyvale, CA 94085-4040</p>		

LITIGATION REVIEW <input checked="" type="checkbox"/>	AJK (examiner initials)	07/14/2010 (date)
Case Name	Director Initials	
OPEN: 2:06cv2469 Net2phone v. Ebay	<i>See Record to GM</i>	

COPENDING OFFICE PROCEEDINGS	
TYPE OF PROCEEDING	NUMBER
1. no copending proceeding	

--	--



UNITED STATES PATENT AND TRADEMARK OFFICE

UNITED STATES DEPARTMENT OF COMMERCE  
 United States Patent and Trademark Office  
 Address: COMMISSIONER FOR PATENTS  
 P.O. Box 1450  
 Alexandria, Virginia 22313-1450  
 www.uspto.gov

BIB DATA SHEET

CONFIRMATION NO. 1061

<b>SERIAL NUMBER</b> 90/010,416	<b>FILING or 371(c) DATE</b> 02/17/2009 <b>RULE</b>	<b>CLASS</b> 709	<b>GROUP ART UNIT</b> 3992	<b>ATTORNEY DOCKET NO.</b> 2655-0188	
<b>APPLICANTS</b> 6108704, Residence Not Provided; NET2PHONE, INC.(OWNER), Newark, NJ; Edwin H. Taylor(3RD PTY REQ), Sunnyvale, CA; Edwin H. Taylor, Sunnyvale, CA;					
<b>** CONTINUING DATA *****</b> This application is a REX of 08/533,115 09/25/1995 PAT 6,108,704					
<b>** FOREIGN APPLICATIONS *****</b>					
<b>** IF REQUIRED, FOREIGN FILING LICENSE GRANTED **</b>					
Foreign Priority claimed <input type="checkbox"/> Yes <input checked="" type="checkbox"/> No 35 USC 119(a-d) conditions met <input type="checkbox"/> Yes <input checked="" type="checkbox"/> No Verified and Acknowledged <i>[Signature]</i> Examiner's Signature	<input type="checkbox"/> Met after Allowance Timels	<b>STATE OR COUNTRY</b>	<b>SHEETS DRAWINGS</b>	<b>TOTAL CLAIMS</b> 44	<b>INDEPENDENT CLAIMS</b> 10
<b>ADDRESS</b> DAVIDSON BERQUIST JACKSON & GOWDEY LLP 4300 WILSON BLVD., 7TH FLOOR ARLINGTON, VA 22203 UNITED STATES					
<b>TITLE</b> Point-to-Point Internet Protocol					
<b>FILING FEE RECEIVED</b> 2520	FEES: Authority has been given in Paper No. _____ to charge/credit DEPOSIT ACCOUNT No. _____ for following:		<input type="checkbox"/> All Fees <input type="checkbox"/> 1.16 Fees (Filing) <input type="checkbox"/> 1.17 Fees (Processing Ext. of time) <input type="checkbox"/> 1.18 Fees (Issue) <input type="checkbox"/> Other _____ <input type="checkbox"/> Credit		



US006108704C1

(12) EX PARTE REEXAMINATION CERTIFICATE (7825th)

United States Patent  
Hutton et al.

(10) Number: US 6,108,704 C1  
(45) Certificate Issued: Oct. 26, 2010

(54) POINT-TO-POINT INTERNET PROTOCOL

FOREIGN PATENT DOCUMENTS

(75) Inventors: Glenn W. Hutton, Miami, FL (US);  
Shane D. Mattaway, Boca Raton, FL  
(US); Craig B. Strickland, Tamarac, FL  
(US)

AU 200059377 A1 11/2000  
AU 200059378 A1 11/2000  
AU 200059379 A1 11/2000  
EP 0455402 A2 11/1991  
EP 0497022 A1 5/1992

(73) Assignee: Net2Phone, Inc., Newark, NJ (US)

(Continued)

Reexamination Request:

No. 90/010,416, Feb. 17, 2009

OTHER PUBLICATIONS

"A Low Cost Solution for: Using your WAN as a Voice Communication Tool" VocalTec White Paper (dated Jun. 3, 1994).

Reexamination Certificate for:

Patent No.: 6,108,704  
Issued: Aug. 22, 2000  
Appl. No.: 08/533,115  
Filed: Sep. 25, 1995

(Continued)

Primary Examiner—Alexander J Kosowski

(51) Int. Cl.  
H04M 1/57 (2006.01)  
H04L 12/58 (2006.01)  
H04L 29/06 (2006.01)

(57) ABSTRACT

A point-to-point Internet protocol exchanges Internet Protocol (IP) addresses between processing units to establish a point-to-point communication link between the processing units through the Internet. A first point-to-point Internet protocol includes the steps of (a) storing in a database a respective IP address of a set of processing units that have an on-line status with respect to the Internet; (b) transmitting a query from a first processing unit to a connection server to determine the on-line status of a second processing unit; and (c) retrieving the IP address of the second unit from the database using the connection server, in response to the determination of a positive on-line status of the second processing unit, for establishing a point-to-point communication link between the first and second processing units through the Internet. A second point-to-point Internet protocol includes the steps of (a) transmitting an E-mail signal, including a first IP address, from a first processing unit; (b) processing the E-mail signal through the Internet to deliver the E-mail signal to a second processing unit; and (c) transmitting a second IP address to the first processing unit for establishing a point-to-point communication link between the first and second processing unit through the Internet.

(52) U.S. Cl. .... 709/227; 709/204

(58) Field of Classification Search ..... None  
See application file for complete search history.

(56) References Cited

U.S. PATENT DOCUMENTS

4,313,035 A 1/1982 Jordan et al.  
4,332,982 A 6/1982 Thomas  
4,410,765 A 10/1983 Hestad et al.  
4,423,414 A 12/1983 Bryant et al.  
4,446,519 A 5/1984 Thomas  
4,450,554 A 5/1984 Steensma et al.  
4,468,529 A 8/1984 Samuel et al.  
4,491,693 A 1/1985 Sano et al.  
4,528,659 A 7/1985 Jones, Jr.  
4,589,107 A 5/1986 Middleton et al.

(Continued)

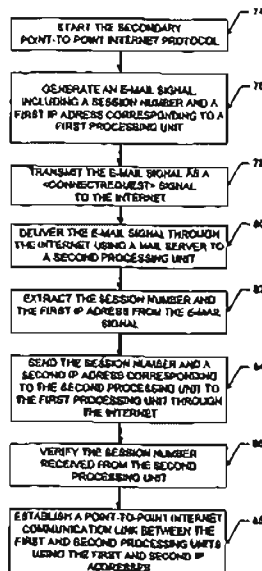

## U.S. PATENT DOCUMENTS

4,594,477 A	6/1986	Noirot	5,247,620 A	9/1993	Fukuzawa et al.
4,598,397 A	7/1986	Nelson et al.	5,249,290 A	9/1993	Heizer
4,602,132 A	7/1986	Nagatomi et al.	5,274,635 A	12/1993	Rahman et al.
4,630,262 A	12/1986	Callens et al.	5,282,197 A	1/1994	Kreitzer
4,652,703 A	3/1987	Lu et al.	5,283,819 A	2/1994	Glick et al.
4,653,090 A	3/1987	Hayden	5,287,103 A	2/1994	Kasprzyk et al.
4,654,483 A	3/1987	Imai et al.	5,301,324 A	4/1994	Dewey et al.
4,658,093 A	4/1987	Hellman	5,305,312 A	4/1994	Fomek et al.
4,694,492 A	9/1987	Wirstrom et al.	5,315,705 A	5/1994	Iwami et al.
4,706,274 A	11/1987	Baker et al.	5,319,705 A	6/1994	Halter et al.
4,740,963 A	4/1988	Eckley	5,325,524 A	6/1994	Black et al.
4,754,479 A	6/1988	Bicknell et al.	5,327,486 A	7/1994	Wolff et al.
4,755,985 A	7/1988	Jayapalan et al.	5,329,619 A	7/1994	Page et al.
4,756,020 A	7/1988	Fodale	5,335,276 A	8/1994	Thompson et al.
4,759,056 A	7/1988	Akiyama	5,341,374 A	8/1994	Lewen et al.
4,782,485 A	11/1988	Gollub	5,347,632 A	9/1994	Filepp et al.
4,799,153 A	1/1989	Hann et al.	5,377,260 A	12/1994	Long
4,800,488 A	1/1989	Agrawal et al.	5,388,213 A	2/1995	Oppenheimer et al.
4,809,271 A	2/1989	Kondo et al.	5,396,485 A	3/1995	Ohno et al.
4,813,040 A	3/1989	Futato	5,402,477 A	3/1995	McMahan et al.
4,819,228 A	4/1989	Baran et al.	5,402,528 A	3/1995	Christopher et al.
4,821,263 A	4/1989	Lundh	5,408,526 A	4/1995	McFarland et al.
4,823,374 A	4/1989	Verlohr	5,408,619 A	4/1995	Oran
4,827,411 A	5/1989	Arrowood	5,410,754 A	4/1995	Favreau et al.
4,829,554 A	5/1989	Barnes et al.	5,425,028 A	6/1995	Britton et al.
4,837,797 A	6/1989	Freony, Jr.	5,428,608 A	6/1995	Freeman et al.
4,866,704 A	9/1989	Bergman	5,432,846 A	7/1995	Norio
4,866,732 A	9/1989	Carey et al.	5,434,913 A	7/1995	Tung et al.
4,873,715 A	10/1989	Shibata	5,440,547 A	8/1995	Easki et al.
4,887,265 A	12/1989	Felix	5,440,632 A	8/1995	Bacon et al.
4,890,282 A	12/1989	Lambert et al.	5,446,891 A	8/1995	Kaplan et al.
4,899,333 A	2/1990	Roediger	5,446,919 A	8/1995	Wilkins
4,899,373 A	2/1990	Lee et al.	5,452,289 A	9/1995	Sharma et al.
4,912,705 A	3/1990	Paneth et al.	5,457,738 A	10/1995	Sylvan
4,914,571 A	4/1990	Baratz et al.	5,459,864 A	10/1995	Brent et al.
4,928,306 A	5/1990	Biswas et al.	5,461,611 A	10/1995	Drake, Jr. et al.
4,932,022 A	6/1990	Keeney et al.	5,461,668 A	10/1995	Zdenek et al.
4,953,159 A	8/1990	Hayden	5,465,286 A	11/1995	Clare et al.
4,962,449 A	10/1990	Schlesinger	5,467,388 A	11/1995	Redd et al.
4,981,371 A	1/1991	Gurak et al.	5,469,500 A	11/1995	Satter et al.
4,989,230 A	1/1991	Gillig et al.	5,473,531 A	12/1995	Flora-Holmquist et al.
4,995,074 A	2/1991	Goldman et al.	5,474,741 A	12/1995	Mikeska et al.
5,031,089 A	7/1991	Liu et al.	5,474,819 A	12/1995	Chambers et al.
5,036,513 A	7/1991	Greenblatt	5,475,741 A	12/1995	Davis et al.
5,040,141 A	8/1991	Yazima et al.	5,475,819 A	12/1995	Miller et al.
5,056,140 A	10/1991	Kimbell	5,481,720 A	1/1996	Loucks et al.
5,065,425 A	11/1991	Lecomte et al.	5,483,524 A	1/1996	Lev et al.
5,107,443 A	4/1992	Smith et al.	5,487,100 A	1/1996	Kane
5,109,403 A	4/1992	Sulphin	5,491,800 A	2/1996	Goldsmith et al.
5,113,499 A	5/1992	Ankney et al.	5,499,295 A	3/1996	Cooper
5,121,385 A	6/1992	Tominaga et al.	5,500,890 A	3/1996	Rogge et al.
5,127,001 A	6/1992	Steagall et al.	5,502,727 A	3/1996	Catanzaro et al.
5,127,003 A	6/1992	Dell, Jr. et al.	5,509,058 A	4/1996	Sestak et al.
5,130,985 A	7/1992	Kondo et al.	5,515,508 A	5/1996	Pettus et al.
5,134,648 A	7/1992	Hochfield et al.	5,517,432 A	5/1996	Chandra et al.
5,136,716 A	8/1992	Harvey et al.	5,524,141 A	6/1996	Braun et al.
5,150,410 A	9/1992	Bertrand	5,528,671 A	6/1996	Ryu et al.
5,153,908 A	10/1992	Kakizawa et al.	5,533,102 A	7/1996	Robinson et al.
5,155,726 A	10/1992	Spinney et al.	5,533,110 A	7/1996	Pinard et al.
5,157,592 A	10/1992	Walters	5,544,164 A	8/1996	Baran
5,159,592 A	10/1992	Perkins	5,544,322 A	8/1996	Cheng et al.
5,164,988 A	11/1992	Matyas et al.	5,546,448 A	8/1996	Caswell et al.
5,185,860 A	2/1993	Wu	5,546,452 A	8/1996	Andrews et al.
5,187,591 A	2/1993	Guy et al.	5,548,636 A	8/1996	Bannister et al.
5,195,086 A	3/1993	Baumgartner et al.	5,548,694 A	8/1996	Friskin Gibson
5,212,789 A	5/1993	Rago	5,555,290 A	9/1996	McLeod et al.
5,214,650 A	5/1993	Reinher et al.	5,563,882 A	10/1996	Bruno et al.
5,220,599 A	6/1993	Sasano et al.	5,572,643 A	11/1996	Judson
5,241,594 A	8/1993	Kung	5,574,774 A	11/1996	Ahlberg et al.
5,241,625 A	8/1993	Epard et al.	5,574,934 A	11/1996	Mirashrafi et al.
			5,581,522 A	12/1996	Sibuya et al.

5,581,702 A	12/1996	McArdle et al.	5,768,527 A	6/1998	Zhu et al.
5,586,257 A	12/1996	Perlman	5,771,355 A	6/1998	Kuzma
5,586,260 A	12/1996	Hu	5,774,656 A	6/1998	Hattori et al.
5,604,737 A	2/1997	Iwami et al.	5,774,660 A	6/1998	Brendel et al.
5,606,669 A	2/1997	Berlin et al.	5,774,666 A	6/1998	Portuesi
5,608,786 A	3/1997	Gordon	5,778,181 A	7/1998	Hidary et al.
5,614,940 A	3/1997	Cobbley et al.	5,778,187 A	7/1998	Monteiro et al.
5,615,257 A	3/1997	Pezzullo et al.	5,784,564 A	7/1998	Carmaisa et al.
5,619,557 A	4/1997	Van Berkum	5,784,619 A	7/1998	Evans et al.
5,621,789 A	4/1997	McCalmont et al.	5,787,253 A	7/1998	McCreery et al.
5,623,483 A	4/1997	Agrawal et al.	5,790,548 A	8/1998	Sistanizadeh et al.
5,623,490 A	4/1997	Richter et al.	5,790,792 A	8/1998	Dudgeon et al.
5,623,605 A	4/1997	Keshav et al.	5,790,793 A	8/1998	Higley
5,625,407 A	4/1997	Biggs et al.	5,790,803 A	8/1998	Kinoshita et al.
5,627,978 A	5/1997	Altom et al.	5,793,365 A	8/1998	Tang et al.
5,636,282 A	6/1997	Holmquist et al.	5,794,018 A	8/1998	Vrvilo et al.
5,636,346 A	6/1997	Saxe	5,794,257 A	8/1998	Liu et al.
5,642,156 A	6/1997	Saiki	5,796,394 A	8/1998	Wicks et al.
5,644,629 A	7/1997	Chow	5,799,063 A	8/1998	Krane
5,649,194 A	7/1997	Miller et al.	5,799,072 A	8/1998	Vulcan et al.
5,651,006 A	7/1997	Fujino et al.	5,799,150 A	8/1998	Hamilton et al.
5,652,759 A	7/1997	Stringfellow, Jr.	5,805,587 A	9/1998	Normis et al.
5,655,120 A	8/1997	Witte et al.	5,805,810 A	9/1998	Maxwell
5,659,542 A	8/1997	Bell et al.	5,805,822 A	9/1998	Long et al.
5,659,596 A	8/1997	Dunn	5,809,233 A	9/1998	Shur
5,668,862 A	9/1997	Bannister et al.	5,812,819 A	9/1998	Rodwin et al.
5,671,412 A	9/1997	Christiano	5,815,665 A	9/1998	Teper et al.
5,671,428 A	9/1997	Muranaga et al.	5,816,919 A	10/1998	Scagnelli et al.
5,675,507 A	10/1997	Bobo	5,818,510 A	10/1998	Cobbley et al.
5,680,392 A	10/1997	Semaan	5,818,836 A	10/1998	DuVal
5,684,800 A	11/1997	Dobbins et al.	5,819,084 A	10/1998	Shapiro et al.
5,684,951 A	11/1997	Goldman et al.	5,822,524 A	10/1998	Chen et al.
5,689,553 A	11/1997	Ahuja et al.	5,825,865 A	10/1998	Oberlander et al.
5,689,641 A	11/1997	Ludwig et al.	5,828,837 A	10/1998	Eikeland
5,692,180 A	11/1997	Lee	5,828,843 A	10/1998	Grimm et al.
5,692,192 A	11/1997	Sudo	5,828,846 A	10/1998	Kirby et al.
5,694,594 A	12/1997	Chang	5,832,119 A	11/1998	Rhoads
5,701,463 A	12/1997	Malcolm	5,832,240 A	11/1998	Larsen et al.
5,708,422 A	1/1998	Blonder et al.	5,835,720 A	11/1998	Nelson et al.
5,708,655 A	1/1998	Toth et al.	5,835,723 A	11/1998	Andrews et al.
5,710,884 A	1/1998	Dedrick	5,835,725 A	11/1998	Chiang et al.
5,717,923 A	2/1998	Dedrick	5,838,683 A	11/1998	Cortley et al.
5,719,786 A	2/1998	Nelson et al.	5,838,970 A	11/1998	Thomas
5,721,827 A	2/1998	Logan et al.	5,841,769 A	11/1998	Okanoue et al.
5,724,092 A	3/1998	Davidsohn et al.	5,842,216 A	11/1998	Anderson et al.
5,724,412 A	3/1998	Srinivasan	5,844,978 A	12/1998	Reuss et al.
5,724,506 A	3/1998	Cleron et al.	5,848,143 A	12/1998	Andrews et al.
5,724,648 A	3/1998	Shaughnessy et al.	5,848,396 A	12/1998	Gerace
5,726,984 A	3/1998	Kubler et al.	5,854,901 A	12/1998	Cole et al.
5,729,748 A	3/1998	Robbins et al.	5,857,072 A	1/1999	Crowle
5,732,078 A	3/1998	Arango	5,864,684 A	1/1999	Nielsen
5,734,828 A	3/1998	Pendse et al.	5,867,156 A	2/1999	Beard et al.
5,736,968 A	4/1998	Tsakiris	5,867,654 A	2/1999	Ludwig et al.
5,742,668 A	4/1998	Pepe et al.	5,867,665 A	2/1999	Butman et al.
5,742,675 A	4/1998	Kilander et al.	5,872,850 A	2/1999	Klein et al.
5,742,762 A	4/1998	Scholl et al.	5,872,922 A	2/1999	Hogan et al.
5,742,905 A	4/1998	Pepe et al.	5,872,972 A	2/1999	Boland et al.
5,745,642 A	4/1998	Ahn	5,883,956 A	3/1999	Le et al.
5,745,702 A	4/1998	Morozumi	5,884,032 A	3/1999	Bateman et al.
5,745,711 A	4/1998	Kitahara et al.	5,884,035 A	3/1999	Butman et al.
5,751,712 A	5/1998	Farwell et al.	5,884,077 A	3/1999	Suzuki
5,751,961 A	5/1998	Smyk	5,890,162 A	3/1999	Huckins
5,754,636 A	5/1998	Bayless et al.	5,892,825 A	4/1999	Mages et al.
5,754,939 A	5/1998	Herz et al.	5,892,903 A	4/1999	Klaus
5,758,110 A	5/1998	Boss et al.	5,892,924 A	4/1999	Lyon et al.
5,758,257 A	5/1998	Herz et al.	5,903,721 A	5/1999	Sixtus
5,761,606 A	6/1998	Wolzien	5,903,723 A	5/1999	Beck et al.
5,764,736 A	6/1998	Shachar et al.	5,903,727 A	5/1999	Nielsen
5,764,741 A	6/1998	Barak	5,905,719 A	5/1999	Arnold et al.
5,764,756 A	6/1998	Onweller	5,905,736 A	5/1999	Ronen et al.
5,767,897 A	6/1998	Howell	5,905,865 A	5/1999	Palmer et al.

5,905,872 A	5/1999	DeSimone et al.	6,282,272 B1	8/2001	Noonen et al.
5,915,001 A	6/1999	Uppaluru	6,289,369 B1	9/2001	Sundaresan
5,923,736 A	7/1999	Shachar	6,300,863 B1	10/2001	Cotichini et al.
5,924,093 A	7/1999	Potter et al.	6,338,078 B1	1/2002	Chang et al.
5,925,103 A	7/1999	Magallanes et al.	6,343,115 B1	1/2002	Foladare et al.
5,928,327 A	7/1999	Wang et al.	6,343,220 B1	1/2002	Van Der Salm
5,929,849 A	7/1999	Kikinis	6,347,085 B2	2/2002	Kelly
5,937,162 A	8/1999	Funk et al.	6,347,342 B1	2/2002	Marcos et al.
5,946,386 A	8/1999	Rogers et al.	6,360,266 B1	3/2002	Pettus
5,946,629 A	8/1999	Sawyer et al.	6,377,568 B1	4/2002	Kelly
5,950,123 A	9/1999	Schweib et al.	6,385,583 B1	5/2002	Ladd et al.
5,950,172 A	9/1999	Klingman	6,393,455 B1	5/2002	Eilert et al.
5,953,350 A	9/1999	Higgins	6,427,064 B1	7/2002	Henderson
5,956,482 A	9/1999	Agraharam et al.	6,434,552 B1	8/2002	Leong
5,956,485 A	9/1999	Pertman	6,463,565 B1	10/2002	Kelly
5,961,584 A	10/1999	Wolf	6,477,586 B1	11/2002	Achenson et al.
5,964,872 A	10/1999	Turpin	6,513,066 B1	1/2003	Hutton et al.
5,969,967 A	10/1999	Aahlad et al.	6,594,254 B1	7/2003	Kelly
5,982,774 A	11/1999	Foladare et al.	6,687,738 B1	2/2004	Hutton
5,983,005 A	11/1999	Monteiro et al.	6,701,365 B1	3/2004	Hutton
5,999,965 A	12/1999	Kelly	6,704,802 B1	3/2004	Finch et al.
6,005,870 A	12/1999	Leung	6,728,784 B1	4/2004	Mattaway
6,006,257 A	12/1999	Slezak	6,772,335 B2	8/2004	Cunis et al.
6,009,469 A	12/1999	Mattaway et al.	6,829,645 B1	12/2004	Hutton
6,014,379 A	1/2000	White et al.	6,888,836 B1	5/2005	Cherkasova
6,014,710 A	1/2000	Talluri et al.	6,909,708 B1	6/2005	Krishnaswamy et al.
6,016,393 A	1/2000	White et al.	2003/0050075 A1	3/2003	Rangarajan et al.
6,018,768 A	1/2000	Ullman et al.	2004/0204146 A1	10/2004	Deeds
6,018,771 A	1/2000	Hayden	2005/0032435 A1	2/2005	Tischer et al.
6,021,126 A	2/2000	White et al.	2005/0130611 A1	6/2005	Lu et al.
6,026,086 A	2/2000	Lancelot et al.			
6,026,425 A	2/2000	Suguri et al.			
6,029,175 A	2/2000	Chow et al.			
6,031,836 A	2/2000	Haserodt			
6,032,192 A	2/2000	Wegner et al.			
6,041,345 A	3/2000	Levi et al.			
6,047,054 A	4/2000	Bayless et al.			
6,047,292 A	4/2000	Kelly et al.			
6,055,594 A	4/2000	Lo et al.			
6,061,716 A	5/2000	Moncreiff			
6,064,975 A	5/2000	Moon et al.			
6,065,048 A	5/2000	Highley			
6,067,350 A	5/2000	Gordon			
6,069,890 A	5/2000	White et al.			
6,085,217 A	7/2000	Ault et al.			
6,101,182 A	8/2000	Sistanizadeh et al.			
6,105,053 A	8/2000	Kimmel et al.			
6,108,704 A	8/2000	Hutton et al.			
6,122,255 A	9/2000	Bartholomew et al.			
6,125,113 A	9/2000	Farris et al.			
6,131,121 A	10/2000	Mattaway et al.			
6,137,877 A	10/2000	Robin et al.			
6,141,341 A	10/2000	Jones et al.			
6,151,643 A	11/2000	Cheng et al.			
6,154,445 A	11/2000	Farris et al.			
6,163,316 A	12/2000	Killian			
6,173,044 B1	1/2001	Hortensius et al.			
6,178,453 B1	1/2001	Mattaway et al.			
6,181,689 B1	1/2001	Choung et al.			
6,185,184 B1	2/2001	Mattaway et al.			
6,188,677 B1	2/2001	Oyama et al.			
6,195,357 B1	2/2001	Polcyn			
6,198,303 B1	3/2001	Rangasoyee			
6,205,135 B1	3/2001	Chinni et al.			
6,212,625 B1	4/2001	Russell			
6,226,678 B1	5/2001	Mattaway et al.			
6,226,690 B1	5/2001	Banda et al.			
6,240,444 B1	5/2001	Fin et al.			
6,243,373 B1	6/2001	Turock			
6,266,539 B1	7/2001	Pardo			
6,275,490 B1	8/2001	Mattaway et al.			

FOREIGN PATENT DOCUMENTS

EP	0518596	12/1992
EP	0556012 A2	8/1993
EP	0559047	9/1993
EP	0581722	2/1994
EP	0597691	5/1994
EP	0632672	1/1995
EP	0648038	4/1995
EP	1379039 A2	1/2004
EP	1379050 A2	1/2004
GB	2283645	5/1995
JP	5944140	3/1984
JP	63-131637	3/1988
JP	6-62020	3/1994
WO	WO-9003074	3/1990
WO	WO-9219054	10/1992
WO	WO-9422087	9/1994
WO	WO-9714234	4/1997
WO	WO-9811704	3/1998

OTHER PUBLICATIONS

"CyberPhone Announcement" Internet Posting in Newsgroups comp.speech, Jun. 8, 1995.

"CyberPhone!" Internet Posting in Newsgroup comp.speech, Apr. 14, 1995.

"Electric Magic Company Provides Internet Alternative to Long-Distance Calls", Electric Magic Company Press Release (Mar. 13, 1995).

"Electric Magic Company Releases NetPhone 1.2 and Netpub Server", Electric Magic Company Press Release (Jun. 1995).

"Frequently-Asked Questions about Tribal Voices PowWow" Version 0.34, Mar. 4, 1996.

"Frequently-Asked Questions about Tribal Voices PowWow" Version 0.43, May 1, 1996.

"Frequently-Asked Questions about Tribal Voices PowWow" Version 0.45, May 31, 1996.



- "Frequently-Asked Questions about Tribal Voices PowWow" Version 0.47, Jun. 12, 1996.
- "Frequently-Asked Questions about Tribal Voices PowWow" Version 0.48, Jun. 25, 1996.
- "Frequently-Asked Questions about Tribal Voices PowWow" Version 0.59, Oct. 30, 1996.
- "NetPhone Gets Internet Users Talking at Local Rates" MacUser UK, Mar. 3, 1995, p. 27.
- "NetPhone Gives Your Mac Voice Over the Internet" Inside the Internet Rocket Science for the Rest of Us, vol. 2, No. 3, Jun. 1995.
- "NetPhone" MacWorld, Jul. 1995.
- "NetPhone" West Coast Online, Ver. 3.02 (#26), Apr. 1995.
- "PowWow 1.3b Now Available!" Google Newsgroup comp.os.ms-windows.misc Discussion Posting (dated Apr. 22, 1995).
- 1996-1997 Buyer's Guide, CTI for Management.
- Abbe Cohen, Inessential Zephyr (Aug. 23, 1993).
- Adam Gaffin, VocalTec Ware Lets Users Make Voice Calls over 'Net, Network World (Feb. 13, 1995).
- Alexander Schill, ed., DCE—The OSF Distributed Computer Environment: Client/Server Model and Beyond, Lecture Notes in Computer Science 731, Karlsruhe University (1993).
- Analysis of DCE Security Draft (Sep. 18, 1996).
- Andrew D. Birrell, et al., Grapevine: An Exercise in Distributed Computing, Communications of the ACM (Apr. 1982).
- Andrew D. Birrell, et al., Grapevine: An Exercise in Distributed Computing, Communications of the ACM, vol. 25, No. 4, Apr. 1982.
- Andrew D. Birrell, et al., Implementing Remote Procedure Calls, ACM Transactions on Computer Systems (Feb. 1984).
- Andrew S. Tanenbaum, Computer Networks, 2d ed. (Prentice-Hall, 1988).
- Andy Patrizio, Telecom, Digital Limits Begin to Blur with 'Phone Calls' Across Internet, PC Week, vol. 12, No. 6 (Feb. 13, 1995).
- Antonio Ruiz, Voice and Telephony Applications for the Office Workstation, IEEE 1st International Conference on Computer Workstations, San Jose, California (Nov. 11-14, 1985).
- AVC-650: Technical Issues Concerning Real-Time Protocol in H.322 Systems in ATM and Other Packet-Switched Computer Networks, Jul. 9, 1994.
- AVC-655: Communication Procedure for H.222.1, Jul. 1, 1994.
- AVC-666: H.32X Communication Modes, Terminal Types and Interworking Scenarios, Jul. 1994.
- AVC-683: Update Draft H.322 Following Grimstad Meeting, Nov. 1994.
- AVC-696: An Example of Call Setup Procedure in a H.322 Terminal, Nov. 1994.
- AVC-702: Terminal to Terminal Signaling in H.32X, Oct. 24, 1994.
- AVC-707R: Report of the Seventeenth Experts Group Meeting in Singapore (Jul. 1-11, 1994)—Part I and Part II, Nov. 11, 1994.
- AVC-716: Draft Recommendation H.32X, Jan. 1995.
- AVC-718: Draft H.32X, Jan. 1995.
- AVC-743R: Report of the Eighteenth Experts Group Meeting in Kamifukuoka (Jan. 24-27, 1995), Jan. 27, 1995.
- AVC-748: Update of Draft Recommendation H.322, May 1995.
- AVC-750: Report of the Study Group 15 Meeting Held During Feb. 6-17, 1995, Feb. 24, 1995.
- AVC-752: Open Issues Towards the Stockholm Meeting, Mar. 17, 1995.
- AVC-758: Draft Recommendation H.323 Visual Telephone Systems and Terminal Equipment for Local Area Networks Which Provide A Non-Guaranteed Quality of Service, Rev. May 12, 1995.
- AVC-767: Logical Channel Set-up Procedure, Apr. 28, 1995.
- AVC-799: Comments on Draft H.323 and H.22Z, May 11, 1995.
- AVC-800R: Report of the Nineteenth Experts Group Meeting in Haninge (May 15-18, 1995), May 18, 1995.
- AVC-813: Signaling Recommendation Within the Scope of H.323, Sep. 10, 1995.
- AVC-819: LAN Addressing Plan in H.323, Sep. 10, 1995.
- AVC-830: Connection Management Procedures for H.323, Oct. 24-27, 1995.
- AVC-842: Gateway, Gatekeeper and Terminal Procedures in H.323, Oct. 17, 1995.
- Avnish Aggarwal, et al., RFC 1002: Protocol Standard for a NetBIOS Service on a TCP/UDP Transport: Detailed Specifications (Mar. 1987).
- Barbara Darrow, Internet Phone Chat Software Prompts Spat: IRC Operators Rebuffed Use of Their Systems, Computer Reseller News (Mar. 20, 1995).
- Barry Michael Arons, The Audio-Graphical Interface to a Personal Integrated Telecommunications System, Masters Thesis, Massachusetts Institute of Technology (Jun. 1984).
- Barry Phillips, Casting the Net for New Media, OEM Magazine, No. 320 (1995).
- Belville, Sharon, "Zephyr on Athena", Athena Documentation, Sep. 10, 1991, Version 3.
- Ben Mesander, et al., The Client-To-Client Protocol (Aug. 12, 1994).
- Bill Welsh, H.245 Implementors' Guide (undated but references Apr. 1996).
- Bob Blakley's Email to sig-dce-security, DCE Delegation Proposal Review, Jul. 7, 1992.
- Brad Curtis Johnson, A Distributed Computing Environment Framework: An OSF Perspective (1991).
- Brent Nordin, et al., Remote Operation Across a Network of Small Computers (Association of Computing Machinery, 1986).
- Brian Fox, et al., GNU Finger program documentation, Free Software Foundation (1992).
- Bruce Brown, BugNet Bug/Fix List, Newsbytes (Dec. 13, 1995).
- Bruce Brown, BugNet Bug/Fix List, Newsbytes (Dec. 13, 1996).
- Butler W. Lampson, et al., A Distributed Systems Architecture for the 1990's (Dec. 17, 1989).
- Buy Memory Configured Expressly for Your Computer, San Jose Mercury News (Jul. 16, 1995).
- C. Anthony DellaFera, et al., Section E.4.1: Zephyr Notification Service, Athena Technical Plan (Jul. 29, 1988).
- C. Anthony DellaFera, et al., Section E.4.1: Zephyr Notification Service, Project Athena Technical Plan (Jun. 5, 1989).
- C. Anthony DellaFera, et al., The Athena Notification Service: Zephyr (1987).
- C. Anthony DellaFera, et al., The Athena Notification Service: Zephyr (Dec. 31, 1987).

- C. Anthony DellaFera, et al., The Zephyr Notification Service (undated).
- C. Anthony DellaFera, et al., The Zephyr Notification Service, Usenix Winter Conference, Feb. 9-12, 1988.
- C. Anthony DellaFera, et al., The Zephyr Notification Service, MIT Project Athena, Winter Usenix Conference (Feb. 12, 1988).
- C. Malamud, et al., RFC 1528: Principles of Operation for the TPC.INT Subdomain: Technical Procedures (Oct. 1993).
- C. Malamud, et al., RFC 1530: Principles of Operation for the TPC.INT Subdomain: General Principles and Policy (Oct. 1993).
- C. Sunshine, et al., IEN 135: Addressing Mobile Hosts in the ARPA Internet Environment (Oct. 1985).
- C. Yang, RFC 1789: INETPhone: Telephone Services and Servers on Internet (Apr. 1995).
- Calls Waiting on the Internet Although Telephone Software Makes 'Free' Long Distance Possible, it's a Long Way from Practical, Kansas City Star (Jul. 14, 1996).
- Carl Sunshine, IEN 178: Addressing Problems in Multi-Network Systems (Apr. 1981).
- Charles E. Perkins, et al., A Mobile Networking System Based on Internet Protocol, IEEE Personal Communications (First Quarter 1994).
- Charlie Kaufman's Email to dmackey re DCE 1.1 Delegation Proposal for Review, Jun. 22, 1992.
- Chii-Ren Tsai, et al., Distributed Audit with Secure Remote Procedure Calls (1991).
- Christopher Schmandt, et al., An Audio and Telephone Server for Multi-Media Workstations, IEEE (1988).
- Christopher Schmandt, et al., Phone Slave: A Graphical Telecommunications Interface, Society for Information Display, 1984 International Symposium Digest of Technical Papers (Jun. 1984).
- Chuck Kane, List of IRC servers as of Feb. 1, 1995, available at <http://ftp.funet.fi/pub/unix/irc/does/servers.950201>.
- Clinton Wilder, Pulling in the Net—InfoSeek, VocalTec Offer Search and Voice Options to Internet Users Online, Informationweek, No. 516 (1995).
- Common Desktop Environment 1.0—Advanced User's and System Administrator's Guide, Addison-Wesley Publishing Co. (1995).
- Common Desktop Environment 1.0—User's Guide, Addison-Wesley Publishing Co. (1995).
- Communications Connectivity Networking, Microsoft Systems Journal, vol. 10, No. 1 (Jan. 1995).
- Comp.Speech FAQ Archive: Comp.Speech FAQ Web Page, Comp.Speech Newsgroup, Jul. 17, 1995).
- Comp.Speech FAQ Weekly Reminder, Comp.Speech Newsgroup (Jun. 21, 1995).
- Contents, Preface, and Index to Open Software Foundation, X/Open Preliminary Specification—X/Open DCE: Authentication and Security Services (Mar. 1996).
- Conversation Excerpt from <ftp://svr-ftp.eng.cam.ac.uk/pub/pub/comp.speech/archive/subject5xxx.txt> accessed on Nov. 28, 2007.
- Craig Crossman, Free Calls on Internet are CB-Style No Longer, Miami Herald (Jun. 26, 1995).
- Craig Crossman, Make Long Distance Calls Via the Internet, Record (Jul. 3, 1995).
- D. O'Mahoney, 1st Generation Internet Phones (1998).
- D. Reed, RFC 1324: A Discussion on Computer Network Conferencing (May 1992).
- D. Zimmerman, RFC 1288: The Finger User Information Protocol (Dec. 1991).
- Dale Skran, Draft ITU-T Recommendation H.225.0—Line Transmission of Non-Telephone Signals, Media Stream Packetization and Synchronization on Non-Guaranteed Quality of Service LANs (May 28, 1996).
- Dale Skran, ed. ASN.1 for H.225.0 (Jun. 18, 1996).
- Dan Cohen, IEN 31: On Name, Addresses and Routings (II) (Apr. 28, 1978).
- Dan Keating, Ring! It's Computer Calling Phone By Internet Has Gotten Better, Miami Herald (May 22, 1996).
- Daniel C. Swinehart, Telephone Management in the Etherphone System, IEEE (1987).
- Daniel H. Craft, Resource Management in a Decentralized System, Operating Systems Review, vol. 17, No. 5 (Association for Computing Machinery, Oct. 1983).
- Danny Cohen, IEN 23: On Name, Addresses and Routings (Jan. 23, 1978).
- Dave Lindbergh, H.323 Encryption, Document: CNC-96-22 (Apr. 15, 1996).
- David D. Clark, RFC 814: Name, Addresses, Ports, and Routes (Jul. 1982).
- David Gertler, Hardware and Software Tidbits from Cebit, Seybold Report on Desktop Publishing, vol. 9, No. 8 (Apr. 3, 1995).
- David Hafke, New on the Net—Talk It Up, Windows Magazine, No. 711 (1996).
- David Harvey, All the News That's Fit to Speak, Netguide, No. 301 (1996).
- David R. Cheriton, et al., A Decentralized Naming Facility (Stanford University, Feb. 1, 1986).
- David R. Cheriton, The V Distributed System, Communications of the ACM, vol. 31, No. 3 (Apr. 1988).
- David Rapp, I've Got to Get a Message to You, Instant Messaging Started as an MIT Computer-Science Department Project, Technology Review (2002).
- DCE 1.0 Security Technology, architectural overview documents, Walter Tuvell, Feb. 1997.
- DCE 1.1 Security Technology, architectural overview documents May 1994.
- DCE RPC Internals and Data Structures (Aug. 1993).
- Dean Adams, ed., Security Survival: An indispensable guide to securing your business, X/Open Co. (1996).
- Decided H.225.0 (Jun. 19, 1996).
- Derek C. Oppen, et al., The Clearinghouse: A Decentralized Agent for Locating Named Objects in a Distributed Environment (Association for Computing Machinery, 1983).
- Description of New Zephyr Protocol (undated).
- Digiphone Specifications, from Q1.11 of Section 1 of the comp.speech FAQ Home Page (dated Jan. 6, 1997).
- Douglas B. Terry, et al., The Berkeley Internet Name Domain Server, Usenix Association Software Tool Users Group, Summer Conference, Salt Lake City, Utah (Jun. 12-15, 1984).
- Douglas B. Terry, Structure freeName Management for Evolving Distributed Environments, IEEE 6th International Conference on Distributed Computing Systems, Cambridge, Massachusetts (May 19-23, 1986).
- Douglas Brian Terry, Distributed Name Servers: Naming and Caching in Large Distributed Computing Environments, Ph.D. Thesis, University of California, Berkeley (Feb. 21, 1985).

- Douglas E. Comer, *Internetworking With TCP/IP: vol. 1: Principles, Protocols, and Architecture*, 1st ed. (Prentice-Hall, 1988).
- Douglas E. Comer, *Internetworking With TCP/IP: vol. 1: Principles, Protocols, and Architecture*, 3rd ed. (Prentice-Hall, 1995).
- Douglas E. Comer, *Internetworking With TCP/IP: vol. 1: Principles, Protocols, and Architecture*, 2nd ed. (Prentice-Hall, 1991).
- Douglas W. Johnson, *Internet-Connected Phone Calls Dial in to Lower Prices*, *Computerworld* (Feb. 19, 1996).
- Draft ITU-T Recommendation G.723—Dual Rate Speech Coder for Multimedia Communications Transmitting at 5.3 & 6.3 KBIT/S (Oct. 17, 1995).
- Draft ITU-T Recommendation H.323 Line Transmission of Non-Telephone Signals: Visual Telephone Systems and Equipment for Local Area Networks Which Provide a Non-Guaranteed Quality of Service, (May 28, 1996).
- Draft Recommendation H.323 Visual Telephone Systems and Terminal Equipment for Local Area Networks Which Provide A Non-Guaranteed Quality of Service, Sep. 8, 1995.
- Draft Recommendation H.323—Visual Telephone Systems and Equipment for Local Area Networks Which Provide A Non-Guaranteed Quality of Service (May 28, 1996).
- E.D. Sykas, et al., *Overview of the CCITT X500 Recommendations Series* (Butterworth-Heinemann, 1991).
- Electric Magic Company Sales Invoices, Feb. 23, 1995 thru Dec. 3, 1995.
- Electric Magic Company, Beta Test License Agreement (dated May 30, 1995).
- Elizabeth Feinler, et al., RFC 810: DoD Internet Host Table Specification (Mar. 1, 1982).
- Ellen Massmer, *PictureTel Brings Video to the Lan Network World* (Sep. 4, 1995).
- E-mail from Dale Skran to jtoga@ibeam.jf.intel.com, phone numbers for email list (Jan. 6, 1997).
- E-mail from Dale Skran to jtoga@ibeam.jf.intel.com, mailing list to enter (Jan. 6, 1997).
- E-mail from Ofer Shapiro to Bob Bell, et al., RE: Destination side gateway problem (Jul. 29, 1996).
- E-mail from Sakae Okubo to Experts of ITU-T SG16 Q.12/16, Q.13/16 and Q.14/16, Notice of the Q.12-14/16 Sunriver meeting (Jul. 17, 1997).
- Email from Sakae Okubo to yves.robin-champigneu@oissy.cnet.fr, et al., Working tools of SG16 experts groups (May 8, 1997).
- E-mail from Vincet Kumar to h323implementors@mailbag.jf.intel.com Receiver associating a logical channel with a RTP stream (Aug. 5, 1996).
- Erdos, Marlina and Pato, Joseph, "Extending the OSF DCE Authorization System to Support Practical Delegation," Feb. 11, 1993.
- Eric C. Rosen, IEN 183: Logical Addressing (May 1981).
- Eric C. Rosen, IEN 188: Issues in Internetting Part 3: Addressing (Jun. 1981).
- Etherphone: *Collected Papers 1987-1988*, Xerox PARC, CSL-89-2 (May 1989).
- Eve M. Schooler, Case Study: Multimedia Conference Control in a Packet-Switched Teleconferencing Systems, *Journal of Internetworking: Research and Experience*, vol. 4, No. 2 (Jun. 1993).
- Eve M. Schooler, et al., *An Architecture for Multimedia Connection Management*, *Proceedings IEEE 4th Comsoc International Workshop on Multimedia Communications*, MM '92, Monterey, California (Apr. 1992).
- Eve M. Schooler, *The Connection Control Protocol: Architecture Overview* (Jan. 28, 1992).
- Eve M. Schooler, *The Connection Control Protocol: Specification, Version 1.1* (Jan. 29, 1992).
- Eve M. Schooler, *The Impact of Scaling on Multimedia Connection Architecture*, *Multimedia Systems*, vol. 1 (Association for Computing Machinery, 1993).
- Exportability of DCE Multi-Crypto Feature by Walter Tuvell, Mar. 5, 1996.
- F. Anklesaria, et al., RFC 1436: The Internet Gopher Protocol (A Distributed Document Search and Retrieval Protocol) (Mar. 1993).
- FAQ: How Can I Use the Internet as a Telephone, Ver. 0.2 (Apr. 27, 1995).
- FAQ: How Can I Use the Internet as a Telephone, Ver. 0.4 (Feb. 23, 1996).
- Fax from Ryan Holmquist to Dale Skran (May 30, 1996).
- FLEXIm v3.0 Programmer's Guide, Globetrotter Software, Inc. (Aug. 1994).
- Full Duplex Internet Voice Comms Available, *Newsbytes* (Feb. 14, 1995).
- Gary A. Thom, H.323: The Multimedia Communications Standard for Local Area Networks, *IEEE Communications Magazine* (Dec. 2006).
- Gilbert Held, *The ABCs of IP Addressing*, CRC Press LLC (2002).
- Gligor, et al., "On Inter-realm Authentication in Large Distributed Systems" May 2, 1992.
- Google Groups "CyberPhone" Search Results, search conducted on Nov. 28, 2007.
- Goretsky, Aryeh "PowWow Quick Installation Guide", 1996.
- Green, Andrew, *NetPhone Tasks and Plans*, Email, 2 pages (printed Feb. 2, 1995).
- Greg Wood, *Computer VAR Takes His First Computer Telephony Plunge*, *Computer Telephony* (Sep. 1996).
- Gursharan S. Sidu, et al., *Inside Apple Talk*, 2d ed. (Addison-Wesley Publishing Co., 1990).
- H. Schulzrinne, et al., RFC 1889: RTP: A Transport Protocol for Real-Time Applications (Jan. 1996).
- Handwritten Notes, Electric Magic Company (dated Jul. 22, 1994 thru Aug. 30, 1995).
- How Can I use the Internet as a telephone? from Q1.11 Section 1 of the comp.speech FAQ Home Page (dated Mar. 19, 1996).
- Hussein M. Abdel-Wahah, XTV: A Framework for Sharing X Window Clients in Remote Synchronous Collaboration, *IEEE Conference on Communications Software: Communications for Distributed Applications & Systems* (Apr. 1991).
- I. C. Weider, et al., RFC 1727: A Vision of an Integrated Information Service (Dec. 1994).
- Inder Gopal, et al., *Directories for Networks with Casually Connected Users* (IEEE, 1988).
- Information Technology—Database Language SQL (Proposed revised text of DIS 9075), Digital Equipment Corp. (Jul. 1992).
- InterFACE from Hijinx Specifications, from Q1.11 of Section 1 of the comp.speech FAQ Home Page (dated Mar. 19, 1995).

- Internet Phone from VocalTec Specifications, from Q1.11 of Section 1 of the comp.speech FAQ Home Page (dated Mar. 19, 1996).
- Internet Phone Release 4, Users Manual, VocalTech 1996.
- Internet Telephone Companies Racing to Market, Voice Technology & Services News, vol. 14 No. 20 (Oct. 3, 1995).
- Introduction to OSF DCE (Prentice-Hall, Inc., 1992).
- ITU-T Recommendation X.500—Information technology—Open Systems Interconnection—The Directory: Overview of concepts, models and services (Aug. 1997).
- ITU-T Recommendation X.501—Information technology—Open Systems Interconnection—The Directory: Models (Aug. 1997).
- J. Oikarinen, et al., RFC 1459: Internet Relay Chat Protocol (May 1993).
- J. Pato, Hierarchical Trust Relationships for Inter-Cell Authentication, Slides, (Jul. 7, 1992).
- J. Pato, RFC 7.0: Hierarchical Trust Relationships for Inter-Cell Authentication (Jul. 1992).
- J. Postel, et al., RFC 959: File Transfer Protocol (FTP) (Oct. 1985).
- J. Postel, RFC 765: File Transfer Protocol (Jun. 1980).
- J. Postel, RFC 925: Multi-LAN Address Resolution (Oct. 1984).
- J. Saltzer, RFC 1498: On the Naming and Binding of Network Destinations (Aug. 1993).
- Jack Rickard, Voice Over Internet—the Internet Phone, Boardwatch Magazine, vol. 9, No. 4 (Apr. 1995).
- James M. Bloom, et al., Experiences Implementing Bind, A Distributed Name Server for the Darpa Internet (Jun. 9–13, 1986).
- James Martin, et al., TCP/IP Networking: Architecture, Administration, and Programming (Prentice Hall, 1994).
- James Staten, NetPhone 1.2 Calls the Web, Macweek, vol. 9 No. 27 (Jul. 10, 1995).
- Jennifer G. Steiner, et al., Kerberos: An Authentication Service for Open Network Systems, Usenix Winter Conference, Dallas, Texas (Feb. 9–12, 1988).
- Joe Maloney, DCE: Focus on Security, the Internet and the Future (printed Apr. 25, 2002, date unknown).
- Joe Pato, et al., Distributed Computing Environment (DCE) Design of the Security Services and Facilities (Aug. 10, 1992).
- Joe Pato, Extending the DCE Authorization Model to Support Practical Delegation—Extended Summary (Jul. 7, 1992).
- Joe Pato, RFC 3.0: Extending the DCE Authorization Model to Support Practical Delegation—Extended Summary (Jun. 1992).
- Joe Pato, RFC 6.0: A Generic Interface for Extended Registry Attributes (Jun. 1992).
- John A. Pershing, Jr. et al., IEN 162: Transport, Addressing, and Routing in the Wideband Net (Oct. 1980).
- John F. Shoch, IEN 19: Inter-Network Naming, Addressing, and Routing (Jan. 1978).
- John Ioannidis, et al., IP-based Protocols for Mobile Internet-working, Columbia Univ., Dept. of Computer Science (1991).
- John R. Pickens, et al., RFC 756: The NIC Name Server—A Datagram Based Information Utility (Jul. 1979).
- John T. Kohl, The Zephyr Notification Service, First International Athena Technical Conference (Apr. 11, 1991).
- John Veizades, et al., Service Location Protocol, Internet Draft (May 2, 1995).
- Jon Hill, et al., Pow Wow, PC Magazine, vol. 15 No. 17 (Oct. 8, 1996).
- Jon Hill, TeleVox, PC Magazine, vol. 15 No. 17 (Oct. 8, 1996).
- Jon Livesey, Inter-process Communication and Naming in the Mininet System, Eighteenth Annual IEEE Computer Society International Conference, San Francisco, California (1979).
- Jon Postel, RFC 921: Domain Name System Implementation Schedule—Revised (Oct. 1984).
- José M. Bernabeu-Auban, et al., Optimizing a Generalized Polling Protocol for Resource Finding over a Multiple over a Multiple Access Channel, Computer Networks and ISDN Systems 27 (1995).
- Josina M. Arfman, et al., Project Athena: Supporting Distributed Computing at MIT, IBM Systems Journal (1992).
- K. Harrenstein, et al., RFC 811: Hostname Server (Oct. 1985).
- K. Harrenstein, et al., RFC 952: DoD Internet Host Table Specification (Oct. 1985).
- K. Harrenstein, RFC 742: Name/Finger (Dec. 30, 1977).
- Kahane, Opher et al., "Call Mangement Agent System Specification" VoIP Forum Technical Committee Contribution (dated Aug. 15, 1996).
- Karl Auerbach, et al., RFC 1001: Protocol Standard for a NetBIOS Service on a TCP/UDP Transport: Concepts and Methods (Mar. 1987).
- Keith A. Lantz, et al., Towards a Universal Directory Service, 4th PODC Conference Proceedings (Association for Computing Machinery, 1985).
- Ken Harrenstien, et al., RFC 811: Hostnames Server (Mar. 1, 1982).
- Ken Harrenstien, RFC 811: Hostnames Server (Mar. 1, 1982).
- Ken Harrenstien, RFC 812: Nicname/Whois (Mar. 1, 1982).
- Kenneth Hart, Startups, industry mainstays add to Internet phone menu, Communicationsweek Int'l (Nov. 27, 1995).
- Klaus Zeuge, et al., The Client-to-Client Protocol (CTCP) (published no later than Aug. 12, 1994).
- Kohl, John T., "Zephyr Installation and Operation Guide", Draft—Nov. 20, 1989.
- Koster, Steven "The Phone Companies Worst Nightmare" Hotwired, Apr. 1995.
- L. Landweber, et al., Architecture of the CSNET Name Server (Association for Computing Machinery, 1983).
- L. Peter Deutsch, RFC 606: Host Names On-Line (Dec. 1973).
- Larry L. Peterson, A Yellow-Pages Service for a Local-Area Network (Association for Computing Machinery, 1988).
- Larry L. Peterson, The Profile Naming Service, ACM Transactions on Computer Systems, vol. 6, No. 4, (Nov. 1988).
- Lisa Zahn, et al., Network Computing Architecture, Prentice Hall (1990).
- List of Names from a DCE Meeting: attendees from DISA, OSF, DEC, Mitre, HP, Open Market and others (undated).
- Listserve postings by Jon Postel, Dynamic Updated Proposal, dated Sep. 1 and 9, 1993.
- Listserve postings by Susan Thomson, DNS Dynamic Updates, dated Jul. 14, 1994.
- Lon Wagner, New Software Lets Users Talk for Cheap, Virginian-Pilot (Mar. 26, 1995).
- M. Bever, et al., Distributed Systems, OSF DCE, and Beyond (1993).

- M.D. Kudlick, RFC 608: Host Names On-Line (Jan. 10, 1974).
- Making the Most of IP Telephony, VocalTec Annual Report 1997.
- Mark Crispin, RFC 752: A Universal Host Table (Jan. 2, 1979).
- Mark Reid, Ptell Call Control Procedure in H.323 (Jun. 16, 1995).
- Markus Sohlenkamp & Greg Chwelos, Integrating Communication, Cooperation, and Awareness: The DIVA Virtual Office Environment (1994).
- Mic Bowman, et al., Unifers: An Attribute-based Name Server, Software Practice and Experience, vol. 20(4) (Apr. 1990).
- Michael D. Schroeder, et al., Experience with Grapevine: The Growth of a Distributed System, ACM Transactions on Computer Systems (Feb. 1984).
- Michael D. Schroeder, et al., Experience with Grapevine: The Growth of a Distributed System, ACM Transactions on Computer Systems, vol. 2, No. 1 (Feb. 1984).
- Michael F. Schwartz, et al., A Comparison of Internet Resource Discovery Approaches, Computing Systems (Aug. 1992).
- Michael F. Schwartz, et al., A Name Service for Evolving, Heterogeneous Systems, ACM (1987).
- Michael J. Bibeau, A Formative Evaluation of CU-SeeMe, Masters Thesis, Virginia Polytechnic Institute and State University (Feb. 20, 1995) (including CU-SeeMe Users Manual by same author published Jan. 1995).
- Michelle Slatalla, Hold the Phone! You Can Call Long Distance on a Computer For Pennies, But it has its Drawbacks, Newsday (Mar. 14, 1995).
- Mike Kong, et al., Network Computing System Reference Manual, Prentice Hall (1990).
- Mike Kudlick, et al., RFC 627: ASCII Text File of Hostnames (Mar. 25, 1974).
- Mitch Wagner, Phone Home Cheaply Over the I-Way, Open Systems Today (Feb. 20, 1995).
- MITRE Fort Meade Site DCE Meeting Sign in Sheet Jan. 16, 1995.
- Mostafa H. Ammar, et al., Using Hint Tables to Locate Resources in Distributed Systems (IEEE, 1988).
- Motorola Micro TAC International 5000 Series Manual (undated).
- Motorola Micro TAC International 7000 Series (dated May 1994).
- Motorola Micro TAC International 7500 Series (undated).
- Motorola Micro TAC International 8000 Series (undated).
- Nate Zelnick, Chat on the Web: An Overview, Interactive Content, vol. 2, No. 17 (Sep. 1995).
- Nautilus: Secure Computer Telephony, from Q1.11 of Section 1 of the comp.speech FAQ Home Page (dated Aug. 7, 1996).
- NetPhone 1.0 User Manual, Electric Magic Company (document includes date Dec. 31, 1994).
- NetPhone 1.1 User Manual, Electric Magic Company (document includes date Feb. 16, 1995).
- NetPhone Demo Instructions, Electric Magic Company, 1994.
- NetPhone Development Plan (undated).
- NetPhone Development Plan v0.1 (undated).
- NetPhone Digital User Manual, Electric Magic Company, Feb. 26, 1995.
- NetPhone Digital User Manual, Electric Magic Company, Mar. 12, 1995.
- NetPhone Information Manual, Electric Magic Company, May 30, 1995.
- NetPhone Testing Notes, Sep. 28, 1994.
- Netphone, Change Notes, Dec. 6.
- Nigel Hinds, et al., Name Space Models for Locating Services, IBM Canada Laboratory Technical Report 74.074 (1991).
- Norbert Leser, Towards a Worldwide Distributed File System: The OSF DCE File System as an example (Sep. 27, 1990).
- Open Group, Cambridge Information (Jun. 23, 1997).
- Open Software Foundation Security Sig (Mar. 19, 1996).
- Open Software Foundation, DCE Internals Course, Instructor Guide vol. 1 (1992).
- Open Software Foundation, DCE Internals Course, Instructor Guide vol. 2 (1992).
- Open Software Foundation, Industry Analysis of DCE (May 15, 1990).
- Open Software Foundation, Introduction to OSF DCE, Prentice Hall (1992).
- Open Software Foundation, Open Line Magazine (May/Jun. 1990).
- Open Software Foundation, OSF DCE Administration Guide Core Components, PTR Prentice Hall (1993).
- Open Software Foundation, OSF DCE Administration Guide—Extended Services, PTR Prentice Hall (1993).
- Open Software Foundation, OSF DCE Administration Guide—Introduction, PTR Prentice Hall (1993).
- Open Software Foundation, OSF DCE Administration Reference, PTR Prentice Hall (1993).
- Open Software Foundation, OSF DCE Application Development Guide, PTR Prentice Hall (1993).
- Open Software Foundation, OSF DCE Application Development Reference, PTR Prentice Hall (1993).
- Open Software Foundation, OSF DCE User's Guide and Reference, PTR Prentice Hall (1993).
- OSF DCE User's Guide and Reference (Prentice-Hall, Inc., 1993).
- P. Deutsch, et al., RFC 1835: Architecture of the Whois++ Service (Aug. 1995).
- P. Fallstrom, et al., RFC 1914: How to Interact with a Whois++ Mesh (Feb. 1996).
- P. Mockapetris, RFC 882: Domain Names—Concepts and Facilities (Nov. 1983).
- P. Mockapetris, RFC 883: Domain Names—Implementation and Specification (Nov. 1983).
- P. Venkat Rangan, et al., Software Architecture for Integration of Video Services in the Etherphone System, IEEE Journal on Selected Areas in Communications, vol. 9, No. 9 (Dec. 1991).
- P.M. Gopal, et al., Consistent Resource Registration, IBM Technical Disclosure Bulletin, vol. 37, No. 9 (Sep. 1994).
- Part 1 of Open Software Foundation, X/Open Preliminary Specification—X/Open DCE: Authentication and Security Services (Mar. 1996).
- Part 2 chapter 2 thru 5 of Open Software Foundation, X/Open Preliminary Specification—X/Open DCE: Authentication and Security Services (Mar. 1996).
- Part 2 chapter 6 thru 13 of Open Software Foundation, X/Open Preliminary Specification—X/Open DCE: Authentication and Security Services (Mar. 1996).

- Part 3 and Part 4 of Open Software Foundation, X/Open Preliminary Specification—X/Open DCE: Authentication and Security Services (Mar. 1996).
- Pato, Joseph N., A Generic Interface for Extended Registry Attributes, Jul. 7, 1992.
- Paul Albitz, et al., DNS and Bind in a Nutshell (O'Reilly & Associates, 1992).
- Paul Mockapetris, RFC 1034: Domain Name—Concepts and Facilities (Nov. 1987).
- Paul Mockapetris, RFC 1035: Domain Name—Implementation and Specification (Nov. 1987).
- Paul V. Mockapetris, et al., Development of the Domain Name Server, Computer Communication Review, vol. 18, No. 4 (Aug. 1988).
- Paul V. Mockapetris, et al., Development of the Domain Name System, Computer Communication Review (Aug. 1988).
- Phoning By Web, San Francisco Chronicle (Mar. 12, 1996).
- PictureTel Corp., 10-K405/A (filed Jan. 13, 1998).
- PictureTel LiveLan (printed Dec. 3, 2007).
- Ping Lin's Email to mackey, Comments on DCE 1.1 Delegation RFC, Jul. 2, 1992.
- Polle T. Zellweger, et al., An Overview of the Etherphone System and its Applications (IEEE, 1988).
- Postel, RFC 791: Internet Protocol: Darpa Internet Program Protocol Specification (Sep. 1981).
- Postel, RFC 793: Transmission Control Protocol: Darpa Internet Program Protocol Specification (Sep. 1981).
- PowWow for Microsoft Windows User's Guide, Version 1.4B, Documentation by Token White Man (dated 1995).
- PowWow For Microsoft Windows User's Guide, Version 1.5, Documentation by Aryeh Goretsky (dated 1995).
- PowWow For Microsoft Windows User's Guide, Version 1.6 beta 2, Documentation by Aryeh Goretsky (dated 1995).
- PowWow For Microsoft Windows User's Guide, Version 1.6 beta, Documentation by Aryeh Goretsky (dated 1995).
- PowWow For Microsoft Windows User's Guide, Version 1.7 beta 1, Documentation by Aryeh Goretsky (dated 1995).
- PowWow For Microsoft Windows User's Guide, Version 1.7 beta 2, Documentation by Aryeh Goretsky (dated 1995).
- PowWow For Microsoft Windows User's Guide, Version 1.7 beta 3, Documentation by Aryeh Goretsky (dated 1995).
- PowWow For Microsoft Windows User's Guide, Version 1.7 beta 4, Documentation by Aryeh Goretsky (dated 1995).
- PowWow For Microsoft Windows User's Guide, Version 2.0 beta 1, Documentation by Aryeh Goretsky (dated 1995, 1996).
- PowWow For Microsoft Windows User's Guide, Version 2.1, Documentation by Aryeh Goretsky (dated 1995, 1996).
- PowWow For Microsoft Windows User's Guide, Version 2.2 beta 1, Documentation by Aryeh Goretsky (dated 1995, 1996).
- PowWow For Microsoft Windows User's Guide, Version 2.2 beta 2, Documentation by Aryeh Goretsky (dated 1995, 1996).
- PowWow For Microsoft Windows User's Guide, Version 2.3, Documentation by Aryeh Goretsky (dated 1995, 1996).
- PowWow For Microsoft Windows User's Guide, Version 2.31, Documentation by Aryeh Goretsky (dated 1995, 1996).
- PowWow For Microsoft Windows User's Guide, Version 2.32, Documentation by Aryeh Goretsky (dated 1995, 1996).
- PowWow For Microsoft Windows User's Guide, Version 3.0 beta 3, Documentation by Aryeh Goretsky (dated 1995, 1996).
- PowWow User Local Server Version 1.0 beta 2 Release Notes (Dated Jun. 18, 1996).
- PowWow User Location Server for Microsoft Windows NT and 95 Version 1.0 beta 2 Installation Guide, by Goresky, Aryeh (dated 1996).
- PowWow Version Release Notes (covering versions 1.4b to 2.32) (dated Jun. 26, 1996).
- PowWow32 Release Notes (PowWow Versions 3.0 beta 3 and 3.0 beta 2) (dated Nov. 21, 1996).
- Prospectus for VocalTech Ordinary Shares, Feb. 6, 1996.
- Questions and Comments: DCE RFC 6.0 "A Generic Interface for Extended Registry Attributes" Commentary by Bob Blakley, Jul. 6, 1992.
- R. Braden, RFC 1644 T/TCP—TCP Extensions for Transactions Functional Specifications (Jul. 1994).
- R. Droms, RFC 1531: Dynamic Host Configuration Protocol (Oct. 1993).
- R. Droms, RFC 1541: Dynamic Host Configuration Protocol (Oct. 1993).
- R.C. Summers, Local-Area Distributed Systems, IBM Systems Journal, vol. 28, No. 2 (1989).
- Raj Pandya, Emerging Mobile and Personal Communication Systems, IEEE Communications Magazine (Jun. 1995).
- RFC 1001: Protocol Standard for a NetBIOS Service on a TCP/UDP Transport: Concepts and Methods, Mar. 1987.
- RFC 1057: RPC Remote Procedure Call Protocol Specification Version 2, Jun. 1988.
- Richard Karpinski, Internet Phones Battle for the Market, Interactive Age, No. 212 (1995).
- Richard Karpinski, Upgrading Internet Phone—VocalTec Offers Full-Duplex Version, Eliminating Voice Delays, Interactive Age, No. 216 (1995).
- Richard T. Snodgrass, Developing Time-Oriented Database Applications in SQL, Morgan Kaufmann Publishers (2000).
- Rivka Tadjer, Internet Communications Solutions: How Well Do They Work?, Computer Shopper, vol. 15, No. 6 (Jun. 1995).
- Rivka Tadjer, Internet Phones to Upstage Videoconferencing Products? Talk is Cheaper with Local Worldwide Dialing, Computer Shopper, vol. 15, No. 5 (May 1995).
- Rob Walters, Computer Telephone Integration (Artech House, 1993).
- Robert E. Kahn, et al., Advances in Packet Radio Technology, Proceedings Of The IEEE (Nov. 1978).
- Robert Gurwitz, et al., IEN 212: IP—Local Area Network Addressing Issues (Sep. 1982).
- Robert J. Williams, User Location Service (Feb. 1996).
- Robert Joseph Fowler, Decentralized Object Finding Using Forwarding Addresses, Ph.D. Thesis, University of Washington (Dec. 1985).
- Robert Richardson, Internet Phone, LAN Magazine, vol. 10, No. 7 (Jul. 1995).
- Robert Richardson, Pow Wow, Anyone? A Web Chat That Works, LAN Magazine, vol. 10 No. 9 (Sep. 1995).
- Robert S. French, et al., The Zephyr Programmer's Manual, Rev. 2.1 (May 5, 1989).
- Rosen, Nick "Internet Opens Line on Cheap Global Phone Calls" The Guardian, Feb. 10, 1995, A1.
- S. Waldbusser, et al., RFC 1742: AppleTalk Management Information Base II (Jan. 1995).
- S.R. Ahuja, et al., The Rapport Multimedia Conferencing System, ACM (1988).

- Sakae Okubo, et al., Draft ITU-T Recommendation H.245—Line Transmission of Non-Telephone Signals: Control Protocol for Multimedia Communication (Nov. 14, 1995).
- Sakae Okubo, et al., ITU-T Recommendation H. 245—Line Transmission of Non-Telephone Signals: Control Protocol for Multimedia Communication (May 20, 1996).
- Sakae Okubo, et al., Line Transmission on Non-Telephone Signals: Control Protocol for Multimedia Communication, Recommendation H245 (May 20, 1996).
- Sakae Okubo, et al., ITU-T Standardization of Audiovisual Communication Systems in ATM and LAN Environments (Apr. 17, 1996).
- Sape J. Mullender, et al., Distributed Match-Making for Processes in Computer Networks (Association for Computing Machinery, 1985).
- Sape Mullender, ed., Distributed Systems, ACM Press (1992).
- Sapwater, E. "Webbed", 2 pages (undated).
- Saruchi Mohan, Internet Phone Accepting Calls, Computerworld (Feb. 27, 1995).
- Savetz, Kevin "Net as Phone" Internet World, Jul. 1995.
- Schill, et al., ed., IFIP/IEEE International Conference on Distributed Platforms—Client/Server and Beyond: DCE, CORBA, ODP & Advanced Distribution Applications, Technical University Bergakademie Freiburg (1996).
- Schulzrinne, Service Conference Invitation Protocol, Internet Draft (Feb. 22, 1996).
- Scott Kahn, Leave Your Message on My PC After the Beep, PC Week (Oct. 3, 1994).
- Sharon Fisher, Fruits of Athena— Academic Projects Like Athen Have Given the World Its First Inking of What Computer Interoperability is All About, Communications Week (1992).
- Snell, Jason "Foiling Ma Bell" MacUser, Jul. 1995.
- Speak Freely, from Q1.11 of Section 1 of the comp.speech FAQ Home Page (dated Mar. 19, 1996).
- Staff Phone List (Jul. 1, 1997).
- Steinberg, Bob "Will Politics Interfere With The Global Internet?" Mashpee Enterprise, Apr. 28, 1995.
- Stephen A. Uhler, PhoneStation, Moving the Telephone onto the Virtual Desktop, 1993, Winter Usenix, San Diego, California (Jan. 25–29, 1993).
- Steve Hamm, The Merry Pranksters, PC Week, vol. 12 No. 34 (Aug. 28, 1995).
- Stuart Harris, The IRC Survival Guide: Talk to the World With Internet Relay Chat (Addison-Wesley, Feb. 1995).
- Sun Microsystems, Inc., RFC 1050: RPC: Remote Procedure Call Protocol Specification Version 2 (Jun. 1988).
- Surfers Can Drop Phones, Electronics Times (Feb. 16, 1995).
- Susan Thomson, et al., DNS Dynamic Updates, IETF DNSIND Working Group (Jul. 1994).
- T. Berners-Lee, et al., RFC 1738: Uniform Resource Locators (URL) (Dec. 1994).
- Tamila Baron, Hearing Voices on the Net, Communications Week (Feb. 20, 1995).
- Tamila Baron, VocalTec, Motorola Team Up for Internet Phone and Modem Bundle, Communications Week, No. 549 (1995).
- Ted Anderson's Email to dmackey re DCE 1.1 Delegation Proposal for Review, Jun. 23, 1992.
- Ted Anderson's Email to pato. Re: RFC 7.0 (really glp92), Jul. 21, 1992.
- The 4.4BSD-Lite distribution announcement, Computer Systems Research Group (Mar. 1, 1994), and related news-group postings, dated Apr. 21–22, 1994.
- The Electric Magic Company, Business Plan, Version 0.1 draft, Apr. 17, 1995.
- The Open Group Organization Chart (Oct. 1997).
- The Open Group Organization Chart Oct. 1996 (Confidential).
- The OSF Distributed Computing Environment: Building on International Standards, OSF White Paper (Apr. 1992).
- The VocalChat User's Guide, Sep. 28, 1993.
- Thomas Maresca, The Internet Phone Company?, Consumer Information Appliance, No. 55 (Feb. 1995).
- TIMOP: DCE Time Operations Sample Application (undated).
- Timothy J. O'Malley, Analysis of the Zephyr Communication Paradigm, Bachelor of Science in Computer Science and Engineering, Thesis, Massachusetts Institute of Technology (May 1993).
- Todd Copilevitz, Heard on the Internet, The Star-Ledger (Mar. 7, 1995).
- Tom Lyons, Network Computing System Tutorial, Prentice Hall (1991).
- Tony Pompili, VocalTec: The Internet, Phone Number?, PC Magazine (May 16, 1995).
- Translation of Japanese Patent Application No. Sho 63(1988)-131637 (Original dated Jun. 3, 1988).
- Transparencies: Walter Tuvell, DCE 1.0 Security Technology—Detailed Architectural Overview (Feb. 1997).
- V. Jacobson, et al., RFC 1185: TCP Extension for High-Speed Paths (Oct. 1990).
- VocalChat 1.01 Network Information (undated).
- VocalChat Early Beta Release 1.02B Information (undated).
- VocalChat GTI 2.12 Beta Retrieval Instructions and Information (undated).
- VocalChat Version 1.0, README.TXT, Nov. 1993.
- VocalChat Version 1.01, README.TXT, Mar. 1994.
- VocalChat Version 2.01 and Wan 2.01, README.TXT, May 1994.
- VocalTec Annual Report, 1996.
- VocalTec Cross-Reference Sheet, Pursuant to Item 501 of Reg. S-K (dated Jan. 1996).
- VocalTec Internet Phone Information Sheet, 2 pages, (dated Jun. 1995).
- VocalTec Internet Phone Version 3.0 Build, 17, README.TXT, Aug. 11, 1995.
- VocalTec Internet Phone Version 3.2 Build 21, README.TXT, Mar. 25, 1996.
- VocalTec SEC 20-F Filing, 1996.
- VocalTec SEC F-1 Filing, Dec. 22, 1995.
- VocalTec SEC F-1 Filing, Jan. 5, 1996.
- Voice Over the Internet, Boardwatch Magazine, vol. IX, No. 1 (Jan. 1995).
- W. David Albrecht, CPA Firms on the World Wide Web, Ohio CPA Journal (Jun. 1996).
- W. Simpson, RFC 1661: The Point-to-Point Protocol (PPP) (Jul. 1994).
- W. Yeong, et al., RFC 1777, Lightweight Directory Access Protocol (Mar. 1995).
- Walt and mactep's ip addresses and code (undated).
- Walter Tuvell, DCE 1.0 Security Technology— Detailed Architectural Overview (Feb. 1997).
- Walter Tuvell, DCE 1.0 Security Technology Detailed Architectural Overview, Draft (Feb. 1997).

- Walter Tuvell, DCE 1.0 Security Technology: Detailed Architectural Overview (Feb. 1997).
- Walter Tuvell, DCE 1.0 Security Technology: Detailed Architectural Overview (May 1994).
- Walter Tuvell, DCE Multi-Crypto Support—Proposal to NSA for Funding and Exportability of Multiple Cryptographic Mechanisms in OSF's Distributed Computing Environment (Sep. 12, 1995).
- Walter Tuvell, Distribution & The Infobahn (1996).
- Walter Tuvell, Exportability of DCE Multi-Crypto Feature (Mar. 5, 1996).
- Walter Tuvell, RFC 98.0: Challenges Concerning Public-Key in DCE (Dec. 1996).
- Walter Tuvell, System V/ONC Comparison to AIX/NCS (Oct. 3, 1988).
- Walter Tuvell, The DCE Dance: Application Development in 29 Easy Steps (Sep. 1991).
- Walter Tuvell, The OSF Distributed Computing Environment (DE). (undated).
- Web Phone, from Q1.11 of Section 1 of the comp.speech FAQ Home Page (dated Mar. 19, 1996).
- WebSTAR Technical Reference (formerly MacHTTP), StarNine Technologies, 1995.
- Wei Hu, DCE Security Programming, O'Reilly & Associates (Jul. 1995).
- Welch, Nathalie "Vendors Ring in New Telephony Options" MacWeek, Apr. 10, 1995, p. 18.
- Wendy Woods, Newsbytes Daily Summary, newsbytes (Jun. 10, 1994).
- William M. Bulkeley, On-line: Hello, world. Audible Chats on the Internet, Wall Street Journal (Feb. 10, 1995).
- Winther, Mark. "The World Wide Web Phones Home: Internet Telephony Market Assessment, 1996-1999", International Data Corporation White Paper (dated 1996).
- Xerox System Integration Standard Clearinghouse Protocol (Apr. 1984).
- Yakov Rekhter, et al., Dynamic Updates in the Domain Name System (DNS): Architecture and Mechanism, Internet-Draft, DNSIND Working Group (Jul. 15, 1994).
- "Circuit Switching", Ericsson last published Jul. 5, 2001, found at <http://www.ericsson.com/multiservicenetworks/circuitswitching/axe/> printed on Aug. 1, 2001, 2 pages.
- "Data Communication Over the Telephone Network", International Telecommunication Union, CCITT The International Telegraph and Telephone Consultative Committee, Blue Book, vol. VIII—Fascicle VIII.1, IXth Plenary Assembly, Melbourne, Nov. 14-25, 1988, pp. 296-370.
- "Full Duplex Speakerphone", IBM Technical Disclosure Bulletin, vol. 29, No. 12, May 1987, pp. 5599-5602.
- "ICL OPD—One Per Desk", Issue Aug. 1, 1990, A Comprehensive Technical Information Document (24 pages).
- "Information Processing Techniques Program, vol. II. Wideband Integrated Voice/Data Technology" Semiannual Technical Summary Report, Massachusetts Institute of Technology Lexington, MA, Oct. 1, 1977-Mar. 31, 1978, Issued Aug. 31, 1978, pp. 1-25 and 27-31, ADA067014.
- "Integrated Voice/Data PABX Communications", IBM Technical Disclosure Bulletin, Sep. 1986, <http://patents.ibm.com>.
- "Level 1-5 of 65 Stories" 1990 Network World, Inc., Apr. 16, 1990, pp. 114-115.
- "Multi-Service Networks", Ericsson, last published Jun. 27, 2001, found at <http://www.ericsson.com/multiservicenetworks/circuitswitching/> printed on Aug. 1, 2001, 2 pages.
- "The History of TPC.INT", Jan. 15, 1999, 2 pages, found at <http://www.tpc.int/faq/history.html> printed on Aug. 8, 2002.
- A. A. Kapauna, et al. "Wideband Packet Access for Workstation: Integrated Voice/Data/Image Services on the UNIX+PC", IEEE Global Telecommunications Conference, Houston, Texas, Dec. 1-4, 1986, Conference Record vol. 3, pp. 1439-1441.
- Ahrens, Richard L., "Frequently-Asked Questions about Internet VoiceChat 1.1 FAQ version: 1.0", 1994, 6 pages.
- Andy Hopper "Pandora—An experimental System for Multimedia Applications", Operating Systems Review, Jan. 12, 1990, pp. 1-16.
- Bennett, Geoff, "Designing TCP/IP Internetworks", Chapter 11, pp. 290, 291 and 323, Van Nostrand Reinhold, 1995.
- Bernard Gold "Digital Speech Networks", Proceedings of the IEEE, vol. 65, No. 12, Dec. 1977, pp. 1636-1658.
- Bill Newman "An ISDN Data and Voice Terminal Based on a Personal Computer", Globecom'85, IEEE Global Telecommunications Conference, Conference Record vol. 3, New Orleans, Louisiana, Dec. 2-5, 1985, pp. 1048-1052.
- Borland, John, "Technology uses one number to find you on any device", May 17, 2001, 3 pages, found at <http://news.cnet.com/news/0-1004-201-5939191-0.html>.
- C. Malamud et al., "Principles of Operation for the TPC.INT Subdomain: General Principles and Policy", RFC 1530, Oct. 1993, pp. 1-7.
- C. Malamud et al., "Principles of Operation for the TPC.INT Subdomain: Remote Printing—Administrative Policies", RFC 1529, Oct. 1993, pp. 1-5.
- C. Malamud et al., "Principles of Operation for the TPC.INT Subdomain: Remote Printing—Technical Procedures", RFC 1528, Oct. 1993, pp. 1-12.
- C. Topolcic "Experimental Internet Stream Protocol, version 2 (ST-II)", Request for Comments 1190, Oct. 1990, pp. 1-148.
- C. Yang, "INETPhone: Telephone Services and Servers on Internet", Request for Comments 1789, pp. 1-6, Apr. 1995.
- Carl A. Sunshine, et al. "Broad-Band Personal Computer LAN's", IEEE Journal on Selected Areas in Communications, vol. SAC-3, No. 3, May 1985, pp. 408-415.
- Cindy Mueller et al., "ATD Data Services", <http://www.iita.ucar.edu/ws/datawshop/Abstract-ATD.html>, Jan. 5, 1995, 2 pages.
- Clifford J. Weinstein, et al. "Experience with Speech Communication in Packet Networks" IEEE Journal on Selected Areas in Communications, vol. SAC-1, No. 6, (ISSN 0733-8716), Dec. 1983, pp. 963-980.
- D. Adolphs, et al. "Adapters for the Public ISDN", pp. 72-80.
- D. Perkins "The Point-to-Point Protocol for the Transmission of Multi-Protocol Datagrams Over Point-to-Point Links", Request for Comments 1171, <ftp://ftp.isi.edu/in-notes/rfc1171.txt>, Jul. 1990, pp. 1-48.
- D.C. Swinehart et al., "Adding Voice to an Office Computer Network", IEEE Global Telecommunications Conference, Nov. 28-Dec. 1, 1983, Conference Record vol. 1 of 3, pp. 392-398.
- Dale Gulick et al., "Interface the ISDN to Your PC With a Voice/Data Board", Design Applications, 2328 Electronic Design, 35 (1987) Dec. 10, No. 29, Hashbrouck Heights, NJ, USA, pp. 85-88, XP 000004313.



- Daniel C. Swinehart "Telephone Management in the Etherphone System", IEEE/IEICE Global Telecommunications Conference '87, Conference Record vol. 2 of 3, Nov. 15-18, 1987, pp. 1176-1180.
- Danny Cohen "A Network Voice Protocol NVP-II", Apr. 1, 1981, pp. 1-68.
- Danny Cohen "Packet Communication of Online Speech", AFIPS Conference Proceedings, 1981 National Computer Conference, May 4-7, 1981, Chicago, Illinois, pp. 169-176.
- Danny Cohen "Specifications for the Network Voice Protocol (NVP)", Request for Comments 741, Jan. 29, 1976, pp. 1-30.
- Don H. Johnson, et al. "A Local Access Network for Packetized Digital Voice Communication", IEEE Transactions on Communications, vol. Com. 29, No. 5, May 1981, pp. 679-688.
- Douglas B. Terry and Daniel C. Swinehart, "Managing Stored Voice in the Etherphone System", 1987 ACM 089791-242-X/87/0011/0103, pp. 103-104.
- Douglas B. Terry and Daniel C. Swinehart, "Managing Stored Voice in the Etherphone System", ACM Transactions on Computer Systems, vol. 6, No. 1, Feb. 1988, pp. 3-27.
- Eve M. Schooler, et al. "A Packet-Switched Multimedia Conferencing System", SIGOIS Bulletin, pp. 12-22.
- Gary C. Kessler "ISDN Concepts, Facilities, and Services", McGraw-Hill, Inc., c1990, pp. 224-231, ISBN 0-07-034242-3.
- Giulio Barberis, et al. "Coded Speech in Packet-Switched Networks: Models and Experiments" IEEE Journal on Selected Areas in Communications, vol. SAC-1, No. 6, Dec. 1983, pp. 1028-1038.
- H. Jonathan Chao, et al. "A Packet Video System Using the Dynamic Time Division Multiplexing Technique", IEEE Global Telecommunications Conference, Houston, Texas, Dec. 1-4, 1988, Conference Record, vol. 3, pp. 0767-0772.
- H. Opderbeck "Throughput Degradations for Single Packet Messages", Request for Comments 632, [ftp://ftp.isi.edu/in-notes/rfc632.txt](http://ftp.isi.edu/in-notes/rfc632.txt), May 20, 1974, pp. 1-6.
- Henning Schulzrinne "Voice Communication Across the Internet: A Network Voice Terminal", Jul. 29, 1992, pp. 1-34.
- Hiroshi Kobayashi and Hideaki Haruyama. "Voice, Data and Video Integrated Broadband Metropolitan Area Network", Electronics and Communications in Japan, Part 1, vol. 73, No. 11, 1990, pp. 34-42.
- Hiroyuki Ichikawa et al. "High-Speed Packet Switching Systems for Multimedia Communications", IEEE Journal on Selected Areas in Communications, Oct. 1987, vol. SAC-5, No. 8 (ISSN 0733-8716), pp. 1336-1345.
- Ian H. Merritt "Providing Telephone Line Access to a Packet Voice Network", University of Southern California, Marina Del Rey, Information Sciences Inst., Feb. 1983, ADA 126270.
- Implementation of Next-Generation Agent-Dedicated Communications, by Agatsuma et al., Tech Report of IEICE 94-216 (Mar. 1995).
- Israel Gitman, et al. "Economic Analysis of Integrated Voice and Data Networks: A Case Study" Proceedings of the IEEE, vol. 66, No. 11, Nov. 1978, pp. 1549-1570.
- J. Huelamo, et al. "End User Premises Equipment and Terminals for Broadband Applications", Electrical Communication, vol. 64, No. 2/3, 1990.
- J. K. Reynolds et al., Voice File Interchange Protocol (VFIP), Request for Comments 978, [ftp://ftp.isi.edu/innotes/rfc978.txt](http://ftp.isi.edu/innotes/rfc978.txt), Feb. 1986, pp. 1-5.
- J. Romkey "A Nonstandard For Transmission of IP Datagrams Over Serial Lines: Slip", Request for Comments 1055, [ftp://ftp.isi.edu/in-notes/std/std47.txt](http://ftp.isi.edu/in-notes/std/std47.txt), Jun. 1988, pp. 1-6.
- James D. Mills, et al. "A data and voice system for the general service telephone network", Proceedings IECON '87, 1987 International Conference on IND. Electronics, Control, and Instrumentation, Cambridge, Massachusetts, Nov. 3-6, 1987.
- James W. Forgie "Speech Transmission in Packet-Switched Store-and-Forward Networks", AFIPS Conference Proceedings, 1975 National Computer Conference, May 19-22, 1975, Anaheim, California, pp. 137-142.
- James W. Forgie "Voice Conferencing in Packet Networks", ICC '80, Conference Record, International Conference on Communications, Seattle, WA, Jun. 8-12, 1980, vol. 1, 80CH1505-6 CSCB, pp. 21.3.1-21.3.4.
- Jane's Military Communications 1979-80, pp. 452 and 453.
- Jane's Military Communications 1985, pp. 585, 546, and 545.
- Jane's Military Communications 1989, Tenth Edition, Edited by John Williamson, ISBN 0710608772, pp. 443, 507, and 512.
- Jane's Military Communications 1990-91, Eleventh Edition, Edited by John Williamson, ISBN 0710609000, pp. [30], 264, 357, 398, 406, 450, 454, 456, 560, 572, 573, 814, 815, and 816.
- Jane's Military Communications 1992-93, Thirteenth Edition, Edited by John Williamson, ISBN 0710609809, pp. 375, 376, 384, and 704.
- Jim Stevens, "Much More Idle Chatter About Reference Models", [http://www.mice.cs.ucl.ac.uk/multimedia/misc/tcp\\_ip/8709.mm.www/0041.html](http://www.mice.cs.ucl.ac.uk/multimedia/misc/tcp_ip/8709.mm.www/0041.html), Dec. 18, 1987, pp. 1-9.
- John Bellamy, "Digital Telephony", c1982 John Wiley & Sons, Inc., pp. 392-397 and 410-412.
- JP Appln. No. 2008-163825 Office Action (Translation).
- K. Sohraby, et al. "ISDN Primary Rate Interface Impact on Performance of Integrated Voice and Data on CSMA/CD Networks—A Measurement and Simulation Study", Globecom '90 IEEE Global Telecommunication Conference & Exhibition, San Diego, California, Dec. 2-5, 1990, vol. 2, pp. 0912-0919.
- Ken Sherman "Data Communications—A User's Guide", 3rd Edition, c1981 Prentice-Hall, Inc., pp. 296-307 and 404-407.
- Kevin Jeffay, et al. "Kernel Support for Live Digital Audio and Video", pp. 10-21 University of North Carolina at Chapel Hill, Department of Computer Science.
- Kyuta Saito, et al. "Voice Packet Communication System for Private Networks", Globecom '89, IEEE Global Telecommunications Conference & Exhibition, Dallas, Texas, Nov. 27-30, 1989, vol. 3, pp. 1874-1878.
- Lawrence G. Roberts "The Evolution of Packet Switching", Proceedings of the IEEE, vol. 66, No. 11, Nov. 1978, pp. 1307-1313.
- Lin, Hwa-Chun and C.S. Raghavendra, "A Dynamic Load-Balancing Policy With a Central Job Dispatcher (LBC)," IEEE Transactions on Software Engineering, vol. 18, No. 2, Feb. 1992, pp. 148-158.

- M. E. Ulug, et al. "Statistical Multiplexing of Data and Encoded Voice in a Transparent Intelligent Network", Fifth Data Communications Symposium, Sep. 27-29, 1977, Snowbird, Utah, pp. 6-14-6-20.
- M. Gopalakrishnan, et al. "Integrating Voice and Data SALAN: An Experimental Local Area Network", Computer Communications, vol. 9, No. 4, Aug. 1986, pp. 186-194 and p. 169.
- M.J. Ross "Alternatives for Integrating Voice and Data", 1981 International Switching Symposium, ISS'81 CIC Montreal, Sep. 21-25, 1981.
- Natesa Janakiraman "An Overview of Recent Developments in the Designs and Applications of Customer Premises Switches", IEEE Communications Magazine, Oct. 1985, vol. 23, No. 10, pp. 32-45.
- P. Borgins-Desbordes, et al. "Variable-Speed Data Transmission", IBM Technical Disclosure Bulletin, vol. 27, No. 4A Sep. 1984, pp. 2269-2270.
- P. Venkat Rangan and Daniel C. Swinehart, "Software Architecture for Integration of Video Services in the Etherphone System", IEEE Journal on Selected Areas in Communication, vol. 9, No. 9, Dec. 1991, pp. 1395-1404.
- Paul Francis, "Comparison of Geographical and Provider-rooted Internet Addressing," Computer Networks and ISDN Systems 27(3)437-448, 1994 (selected paper from INET 94/JENC 5).
- Paul Gilster, "Internet Navigator", Maruzen Kabushiki-Kisha (1st Ed.), pp. 473-476, Feb. 28, 1995 (with translation and SOR).
- Paul Tsuchiya, Tony Eng, "Extending the IP Internet Through Address Reuse," ACM SIGCOMM Computer Communications Review, 23(1):16-33, Jan. 1993.
- Phillip H. Reagan, "Is it the PBX or is it the LAN?", Datamation, The Telecom Manager Emerges, Mar. 1984, vol. 30 No. 3, pp. 3-4, 147, 148, 150.
- Polle T. Zellweger et al., "An Overview of the Etherphone System and its Applications", 2nd IEEE Conference of Computer Workstations, Mar. 7-10, 1988, pp. 160-168.
- R. Braudes et al., "Requirements for Multicast Protocols", Request for Comments 1458, Network Working Group, May 1993, pp. 1-19.
- R. W. Meba, et al. "Experiments in Wideband Packet Technology", Digital Communications—New Directions in Switching and Networks, Proceedings of the International Seminar, Zurich, Switzerland, Mar. 11-13, 1986, pp. 135-139.
- R.P. McNamara, "Some Considerations of the Voice-Data Capabilities of Broadband Cable Networks", IEEE Digest of Papers Spring CompCon 82, Feb. 22-25, 1982, pp. 312-314.
- Randy Cole "Packet Voice: When It Makes Sense", Speech Technology, Sep./Oct. 1982, pp. 52-61.
- Scott Flinn, "Coordinating Heterogeneous Time-Based Media Between Independent Applications" ACM Multimedia 95—Electronic Proceedings Nov. 5-9, 1995, pp. 1-16.
- Shimmi Hatton et al., "Integrated Digital Switching System with Queueing Storage Facility", IEEE Transactions on Communications, vol. Com-30, No. 8, Aug. 1982, pp. 1900-1905, (ISSN 0090-6778).
- Sieve Ollmanns, et al., "A Voice and Communications System for the IBM PC", Speech Technology, Mar./Apr. 1986, pp. 94-99.
- Stuart Cheshire et al., "Internet Mobility 4x4", www.acm.org, 1996, pp. 1-12.
- Susan Angebrannt et al., "Integrating Audio and Telephony in a Distributed Workstation Environment", Proceedings of the Summer 1991 USENIX Conference, Jun. 10-14, 1991, Nashville, Tennessee, pp. 419-435.
- T. Kamae "Visual Terminals and User Interfaces", FGCS North-Holland, pp. 257-278.
- T. Kamae "Voice/Data Integration in the INS Model System and Local Area Networks" IEEE Communications Magazine, Dec. 1986, vol. 24, No. 12, pp. 7-15.
- T7540 Digital Telephone Codec, AT&T Microelectronics, Jan. 1991, pp. 1-62 and Data Sheet Addendum, Jul. 1991, 4 pages.
- Takashi Yamada, et al. "New Technologies—Multimedia High-throughput X.25 Packet Switching System", NTT Review, vol. 1, No. 2, Jul. 1989, pp. 82-88.
- Talk (software) description from Wikipedia.
- Tamohiro Kawai, Nikkei Communications, No. 202, pp. 29-30, Nikkei BP, Jul. 17, 1995 ("Communication software appears on the Internet") (w/SOR).
- Theodore Baifly, et al. "Voice Communication in Integrated Digital Voice and Data Networks", IEEE Transactions on Communication, vol. Com-28, No. 9, Sep. 1980, pp. 1478-1490.
- Toru Tsuda, et al. "An Approach to Multi-Service Subscriber Loop System Using Packetized Voice/Data Terminals" ISSLS '78, The International Symposium on Subscriber Loops and Services, Mar. 20-24, 1978, Atlanta, Georgia, Conference Record, pp. 161-165.
- Translation of Japanese Kokai H07-129488 (published May 19, 1995).
- V. Jacobson, et al. "TCP Extension for High-Speed Paths", Request for Comments 1185, [ftp://ftp.isi.edu/in-notes/rfc1185.txt](http://ftp.isi.edu/in-notes/rfc1185.txt), Oct. 1990, pp. 1-21.
- V. Jacobson, et al. "TCP Extensions for High-Speed Performance", Request for Comments 1323, [ftp://ftp.isi.edu/in-notes/rfc1323.txt](http://ftp.isi.edu/in-notes/rfc1323.txt), May 1992, pp. 1-37.
- Vinton G. Cerf, "Packet Satellite Technology Reference Sources", Request for Comments 829, Nov. 1982, <http://www.cis.ohio-state.edu/hubin/rfc829.html>, pp. 1-5.
- VocalTec Internet Phone (TM) Version 2.5 Readme, VocalTec Ltd., Feb. 1995, 5 pages.
- After Downsizing: Overcoming Client-Server Chaos (May 21, 1994).
- Camelot Corps Shining Internet Dream Draws Skeptics (Aug. 95).
- DigiPhone for Mac (1996).
- Electric Magic Information (May 1995).
- Electric Magic Notebooks (prior to Sep. 1995).
- Electric Magic Press Release (dated Mar. 13, 1995).
- Google Groups comp.dcom.videconf posting (dated Jul. 5, 1995).
- Jabra—Corporate and Product Backgrounder (Apr. 19, 1995).
- Jabra Ear Phone Common Questions and Answers.
- Jabra Ear phone PC, 1995.
- Jabra Streamline Ear Phone, 1993.
- Maven README (including 1994 copyright notice).
- Net as Phone (Internet World Jul. 1995).
- NET phone ad (with Jabra fax line) (May 95).
- NetPhone 1.1 User Manual (including date Jan. 9, 1995).
- NetPhone Advertisement (Aug. 1995).
- NetPhone Digital User Manual (dated Feb. 26, 1995).

- NetPhone gives your Mac voice over the Internet (Inside the Internet—Jun. 1995).
- NetPhone invoices (including invoices prior to Sep. 1995).
- NetPhone Tasks and Plans (dated Jan.–Feb. 1995).
- Open System Today, Feb. 20, 1995.
- Phoneless Phoning Apr. 2, 1995.
- PowWow Chunked Protocol Specification, Last edited Mar. 12, 1999.
- PowWow Native Protocols, last updated Dec. 8, 1998.
- Roadmap for the Internet (Mar. 1995).
- SlipMagic Ad for MacZone (dated Sep. 28, 1995) for selling product.
- The Mac Zone (Catalog) dated 1995.
- Two-way voice calls over the Internet (Nov. 21, 1994).
- Ubique documents relating to Virtual Places Products (dated 1995 and Mar. 1995).
- Ubique Ships Virtual Places Client and Server (dated Mar. 20, 1995).
- Welcome to NetPhone Demo (includes copyright date 1994).
- David Strom, "Talking Telephony", Windows Sources, Ziff-Davis Publishing Company, Sep. 1996, vol. 4, No. 9, pp. 6, 7, 10, 150–152, 157, 158–163, 167, 169, 171, 174, 181, 184, 186, 195, 203, 208.
- Emad Farag et al., "Structure and network control of a hierarchical mobile network architecture", IEEE Fourteenth Annual International Phoenix Conference on Computers and Communications, Mar. 1995, ISBN: 0-7803-2492-7, pp. 671–677.
- English translation of JP-06-62020 (dated Mar. 4, 1994).
- Huanxu Pan et al., "Analysis of a CCSS#7 Network supporting database services", IEEE International Conference on Information Engineering, Sep. 1993, ISBN: 0-7803-1445-X, pp. 193–197, vol. 1.
- John E. Goodwin, Project Gutenberg Alpha Edition of EMAIL 101, <http://metalab.unc.edu/pub/docs/books/gutenberg/etext93/email025.txt>, Jul. 1993.
- Junichi Kimura, et al. "Voice/Data Multiplexing Transmission Methods", Kokai Japanese Patent, Kokai Sho 59-44140, pp. 205–215, with English Abstract, English Translation, pp. 1–24.
- Mark R. Brown et al. "Special Edition: Using Netscape 2", Que Publishing, 1995 ISBN 0-7897-0612-1, pp. 7–35, 37–56, 78, 83, 176, 301–320, 393, 395–467, 469–506.
- Preston Gralla, "How the Internet Works", Ziff-Davis Press, Emeryville, CA, c1997, pp. 34–37, 202–205, 214–215 and 272–275, ISBN 1-56276-552-3.
- VocalChat GTI Information file, believed to be included with VocalChat GTI version 2.12 dated Sep. 1994.
- VocalChat GTI README.TXT for Version 2.12 Beta, dated Sep. 1994.
- VocalChat GTI Troubleshooting, Inf, believed to be included with VocalChat GTI version 2.12 dated Sep. 1994.
- The Open Group, Technical Standard, *Protocols for X/Open PC Interworking: SMB, Version 2*, 1992, pp. ii–xvi and pp. 1–516.
- Zellweger, Polle T., et al., *Etherphone: Collected Papers 1987–1988*, Xerox Corporation, May 1989.
- Vin, Herrick M., et al., *Multimedia Conferencing in the Etherphone Environment*, Oct. 1991, pp. 69–79.
- Droms, R., *Dynamic Host Configuration Protocol, RFC 1531*, Bucknell University, Oct. 1993, pp. 1–39.
- VocalChat User's Guide Version 2.0*, Vocaltec, 1994, pp. 1–77.
- README, VocalChat Version 2.02 & VocalChat WAN Version 2.02*, Vocaltec, Jun. 1994, pp. 1–3.
- VocalChat 1.01 Network Information*, Vocaltec, 1994, pp. 1–10.
- VocalChat Information*, Vocaltec, 1994, pp. 1–31.
- VocalChat Troubleshooting*, Vocaltec, 1994, pp. 1–101.

1  
EX PARTE

REEXAMINATION CERTIFICATE  
ISSUED UNDER 35 U.S.C. 307

THE PATENT IS HEREBY AMENDED AS  
INDICATED BELOW.

Matter enclosed in heavy brackets [ ] appeared in the patent, but has been deleted and is no longer a part of the patent; matter printed in italics indicates additions made to the patent.

AS A RESULT OF REEXAMINATION, IT HAS BEEN DETERMINED THAT:

The patentability of claims 1-7 and 32-42 is confirmed.

Claims 10, 21, 43 and 44 are cancelled.

Claims 11, 12, 14, 15, 16, 19, 22, 23, 25, 27 and 30 are determined to be patentable as amended.

Claims 13, 17, 18, 20, 24, 26, 28, 29 and 31, dependent on an amended claim, are determined to be patentable.

Claims 8-9 were not reexamined.

11. [The method of claim 10] *In a computer system, a method for establishing a point-to-point communication link from a caller process to a callee process over a computer network, the caller process having a user interface and being operatively connectable to the callee process and a server over the computer network, the method comprising the steps of:*

- A. *providing a user interface element representing a first communication line;*
- B. *providing a user interface element representing a first callee process; and*
- C. *establishing a point-to-point communication link from the caller process to the first callee process, in response to a user associating the element representing the first callee process with the element representing the first communication line, wherein step C further comprises the steps of:*
  - c.1 *querying the server as to the on-line status of the first called [process] process; and*
  - c.2 *receiving a network protocol address of the first callee process over the computer network from the server.*

12. The method of claim [10] // further comprising the step of:

- D. *providing an element representing a second communication line.*

14. The method of claim [10] // further comprising the step of:

- D. *providing a user interface element representing a second callee process; and*
- E. *establishing a conference point-to-point communication link between the caller process and the first and second callee process, in response to the user associating the element representing the second callee process with the element representing the first communication line.*

15. The method of claim [10] // further comprising the step of:

- F. *removing the second callee process from the conference point-to-point communication link in response to the user disassociating the element representing the*

2

second callee process from the element representing the first communication line.

16. The method of claim [10] // further comprising the steps of:

- D. *providing a user interface element representing a communication line having a temporarily disabled status; and*
- E. *temporarily disabling a point-to-point communication link between the caller process and the first callee process, in response to the user associating the element representing the first callee process with the element representing the communication line having a temporarily disabled status.*

19. The method of claim [10] // wherein the caller process further comprises a visual display and the user interface comprises a graphic user interface.

22. [The computer program product of claim 21 ] *A computer program product for use with a computer system comprising:*

*a computer usable medium having program code embodied in the medium for establishing a point-to-point communication link from a caller process to a callee process over a computer network, the caller process having a user interface and being operatively connectable to the callee process and a server over the computer network, the medium further comprising:*

- program code for generating an element representing a first communication line;*
- program code for generating an element representing a first callee process;*
- program code, responsive to a user associating the element representing the first callee process with the element representing the first communication line, for establishing a point-to-point communication link from the caller process to the first callee process, ] wherein the program code for establishing a point-to-point communication link further comprises:*
  - program code for querying the server as to the on-line status of the first callee process; and*
  - program code for receiving a network protocol address of the first callee process over the computer network from the server.*

23. A computer program product of claim [21] 22 further comprising: *program code for generating an element representing a second communication line.*

25. The computer program product of claim [21] 22 further comprising: *program code for generating an element representing a second callee process; and program code means, responsive to the user associating the element representing the second callee process with the element representing the first communication line, for establishing a conference communication link between the caller process and the first and second callee process.*

27. The computer program product of claim [21] 22 further comprising:

- program code for generating an element representing a communication line having a temporarily disabled status; and*
- program code, responsive association of the element representing the first callee process with the element representing the communication line having a temporarily disabled status, for temporarily disabling the point-to-point communication link between the caller process and the first callee process.*

30. A computer program product of claim [21] 22 wherein the computer system further comprises a visual display and the user interface comprises a graphic user interface.

\* \* \* \* \*