

PATENT

Atty. Docket No. 649-2

IN THE UNITED STATES PATENT AND TRADEMARK OFFICE

Commissioner of Patents  
and Trademarks  
Washington, D.C. 20231

UTILITY APPLICATION FEE TRANSMITTAL

Sir:

Transmitted herewith for filing is the patent application of

Inventor(s): Glenn W. Hutton

For: POINT-TO-POINT INTERNET PROTOCOL

Enclosed are:

- 28 page(s) of specification
- 1 page(s) of Abstract
- 9 page(s) of claims
- 6 sheets of drawings [ ] formal [X] informal
- 5 page(s) of Declaration and Power of Attorney
- [ ] An Assignment of the invention to \_\_\_\_\_

[ ] Certified copy of applications

<u>Country</u>	<u>Appln. No.</u>	<u>Filed</u>

from which priority under Title 35 United States Code, § 119  
is claimed

- [ ] is enclosed.
- [ ] will follow.

CERTIFICATION UNDER 37 C.F.R. § 1.10

I hereby certify that this New Application Transmittal and the documents referred to as enclosed therein are being deposited with the United States Postal Service on this date September 25, 1995 in an envelope as "Express Mail Post Office to Addressee" Mail Label Number EM302799414US addressed to: Commissioner of Patents and Trademarks, Washington, D.C. 20231.

Wendy Greenscich  
(Type or print name of person mailing paper)  
*Wendy Greenscich*  
(Signature of person mailing paper)

CALCULATION OF UTILITY APPLICATION FEE

For	Number Filed		Number Extra	Rate	Basic Fee \$730.00
Total					
Claims*	20	-20 =	0	x \$22.00	\$
Independent					
Claims	6	-3 =	3	x \$76.00	\$228.00
Multiple	[ ] yes		Add'l. Fee	\$240.00	\$
Dependent					
Claims	[X] no		Add'l. Fee	None	= \$
<b>TOTAL</b>					<b>\$ 958.00</b>

- [X] Verified Statement of "Small Entity" Status Under 37 C.F.R. § 1.27. Reduced fees under 37 C.F.R. § 1.9(f) (50% of total) paid herewith \$479.00.
- [ ] The amount of \$40.00 for recording the attached Assignment is included in the enclosed check.
- [X] A check in the amount of \$479.00 to cover the [ ] recording, [X] filing fee(s) is attached.
- [ ] Charge fee to Deposit Account No. 04-1121. Order No. \_\_\_\_\_  
TWO (2) COPIES OF THIS SHEET ARE ENCLOSED.
- [X] Please charge any deficiency as well as any other fee(s) which may become due under 37 C.F.R. § 1.16 and 1.17, at any time during the pendency of this application, or credit any overpayment of such fee(s) to Deposit Account No. 04-1121. Also, in the event any extensions of time for responding are required for the pending application(s), please treat this paper as a petition to extend the time as required and charge Deposit Account No. 04-1121 therefor. TWO (2) COPIES OF THIS SHEET ARE ENCLOSED.

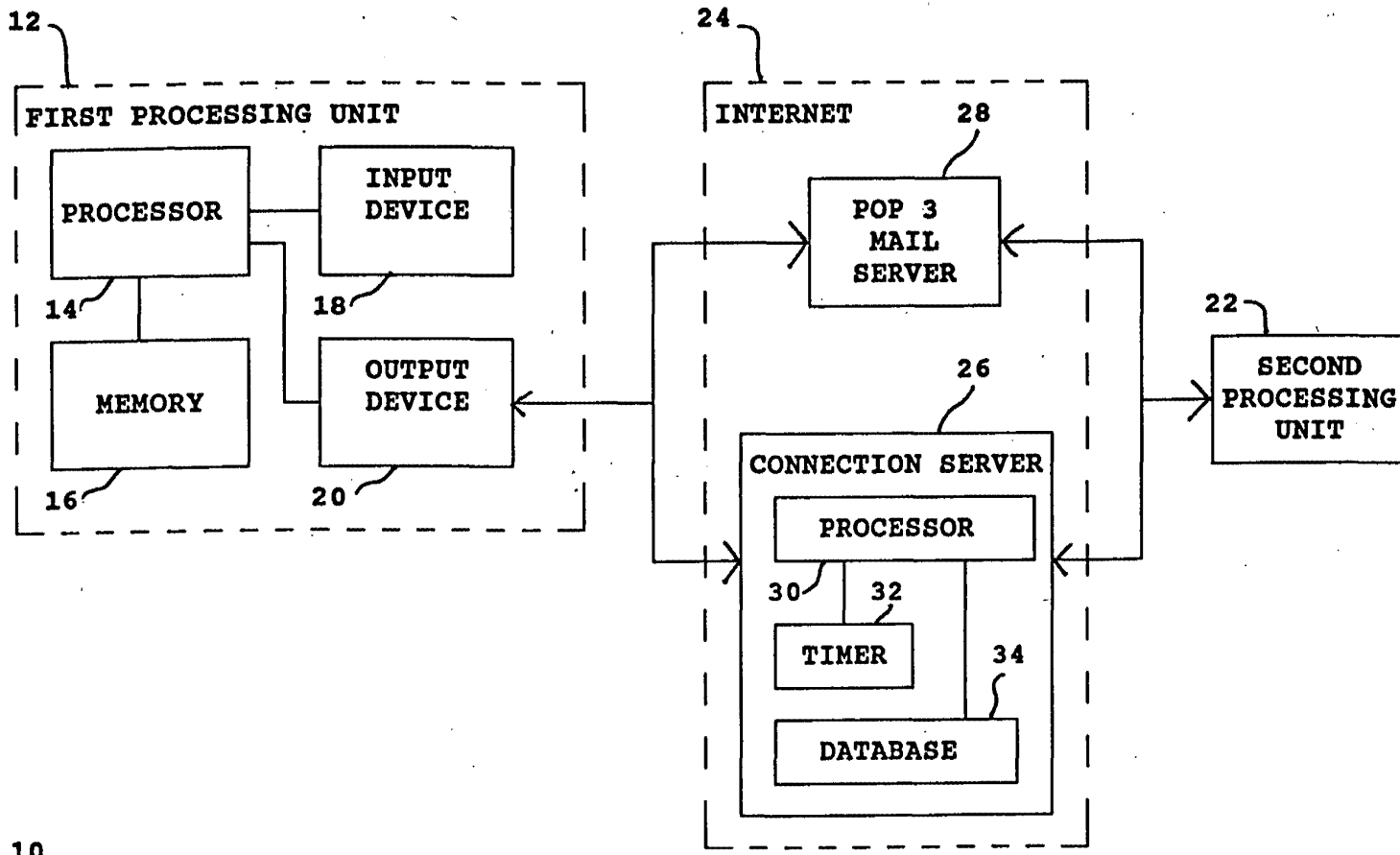
Date: September 25, 1995

  
SIGNATURE OF ATTORNEY

Joseph J. Catanzaro  
Reg. No. 25,837

DILWORTH & BARRESE  
333 Earle Ovington Blvd.  
Uniondale, NY 11553  
Tel. No. (516) 228-8484  
Fax. (516) 228-8516

\*Includes all independent and single dependent claims and all claims referred to in multiple claims. See 37 C.F.R. § 1.75(c).



10

FIG. 1

08 533115

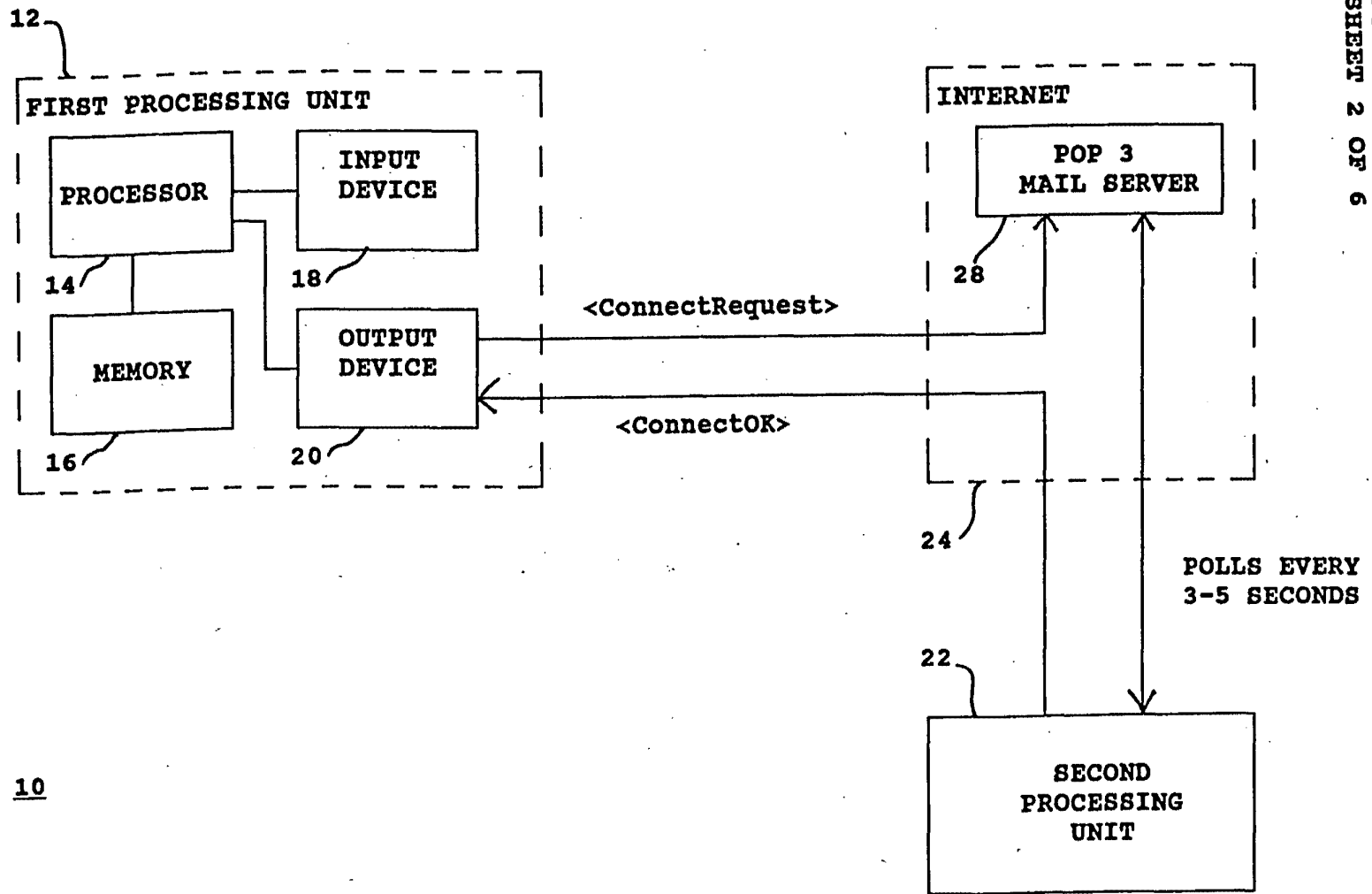
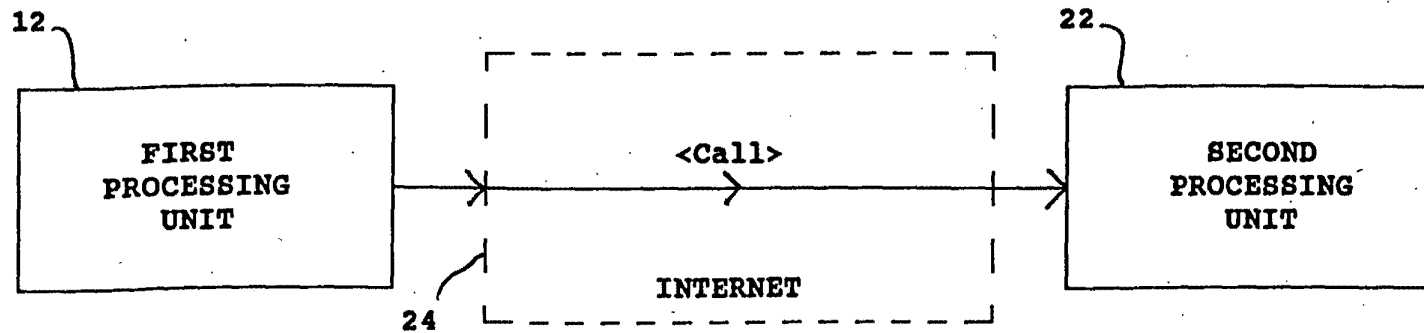
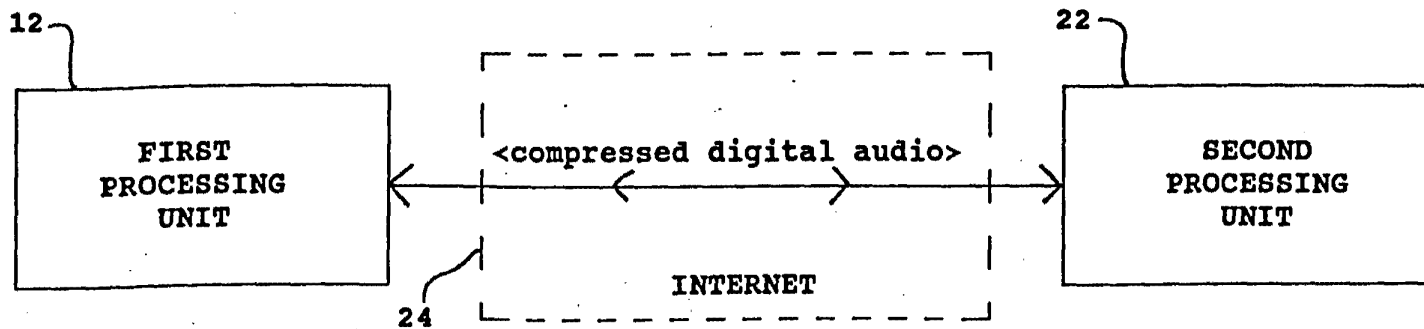


FIG. 2





**FIG. 3**



**FIG. 4**

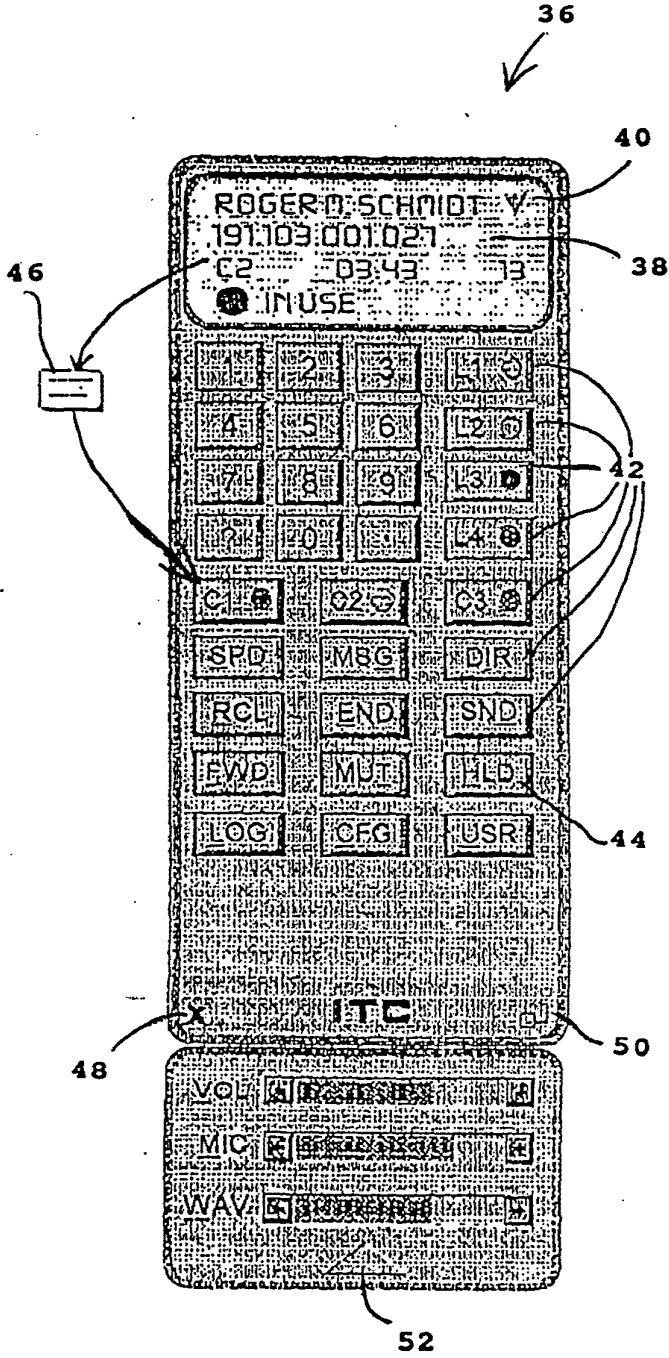


FIG. 5

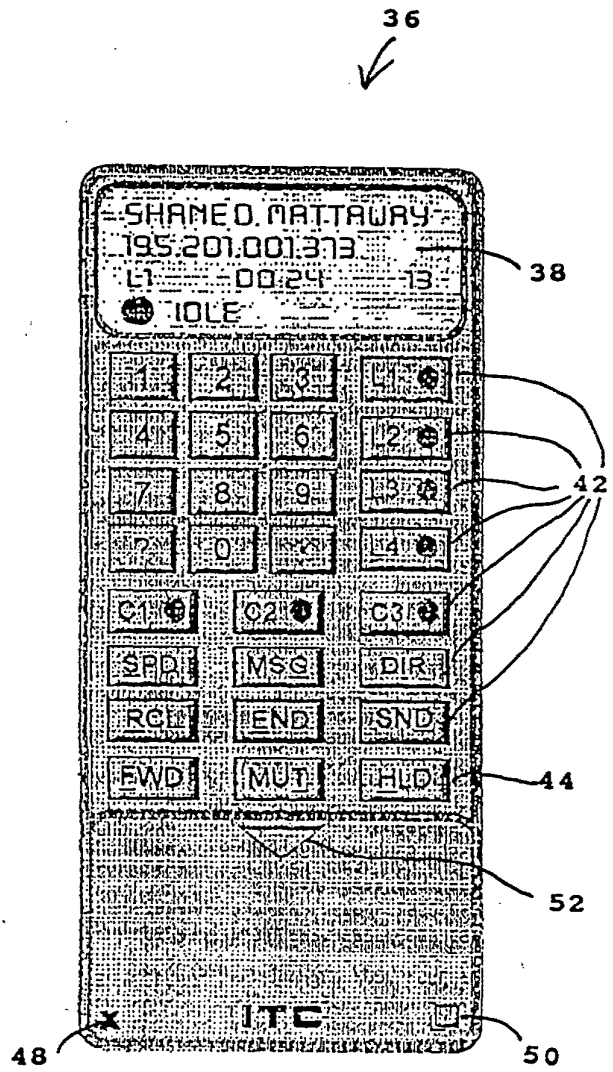


FIG. 6

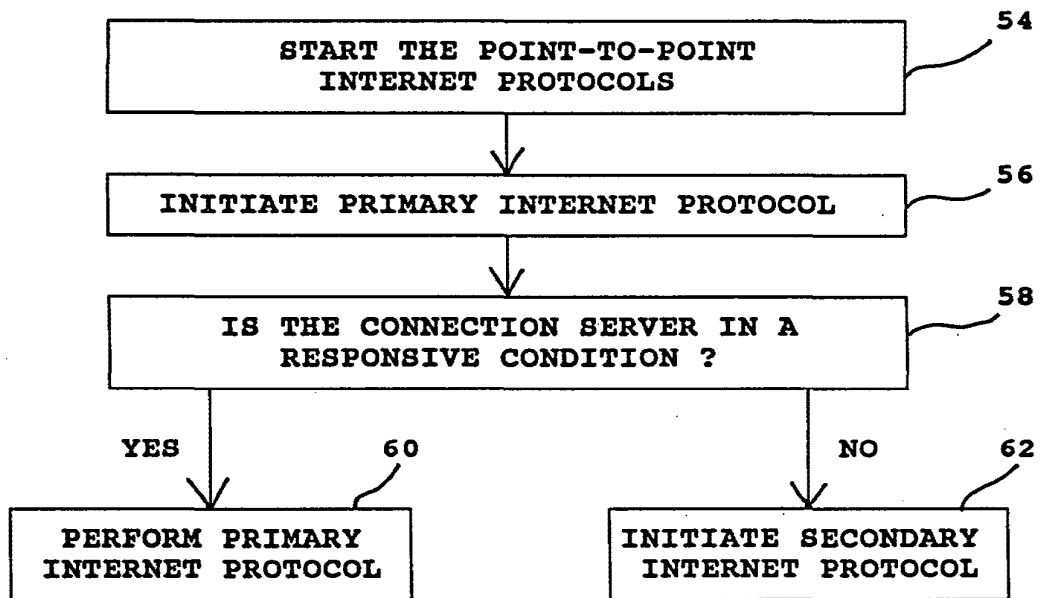


FIG. 7

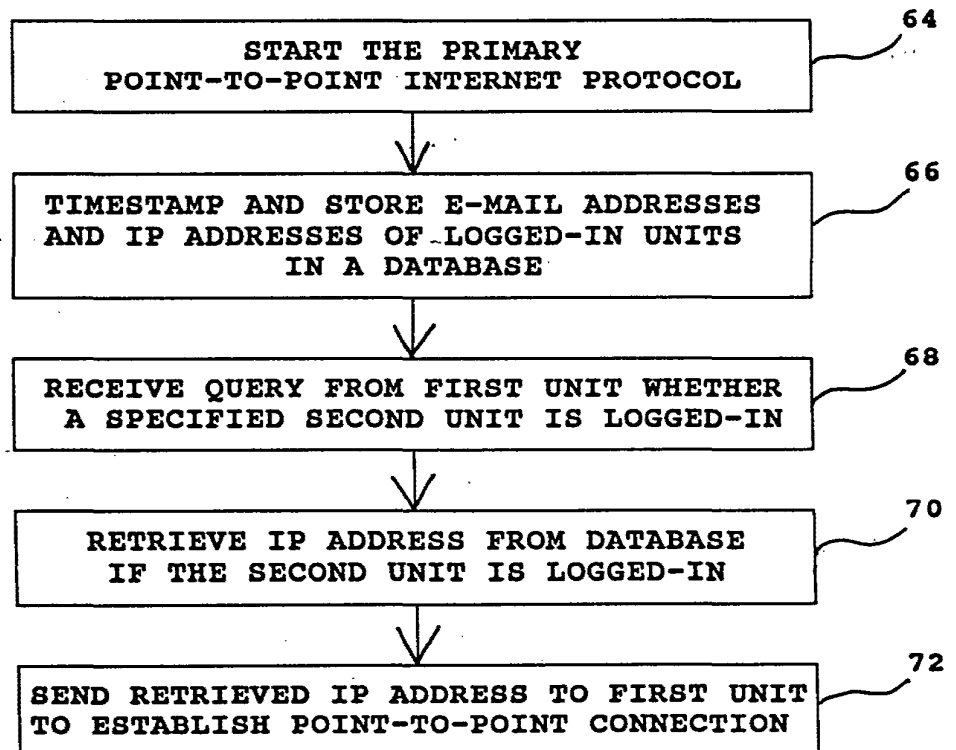


FIG. 8

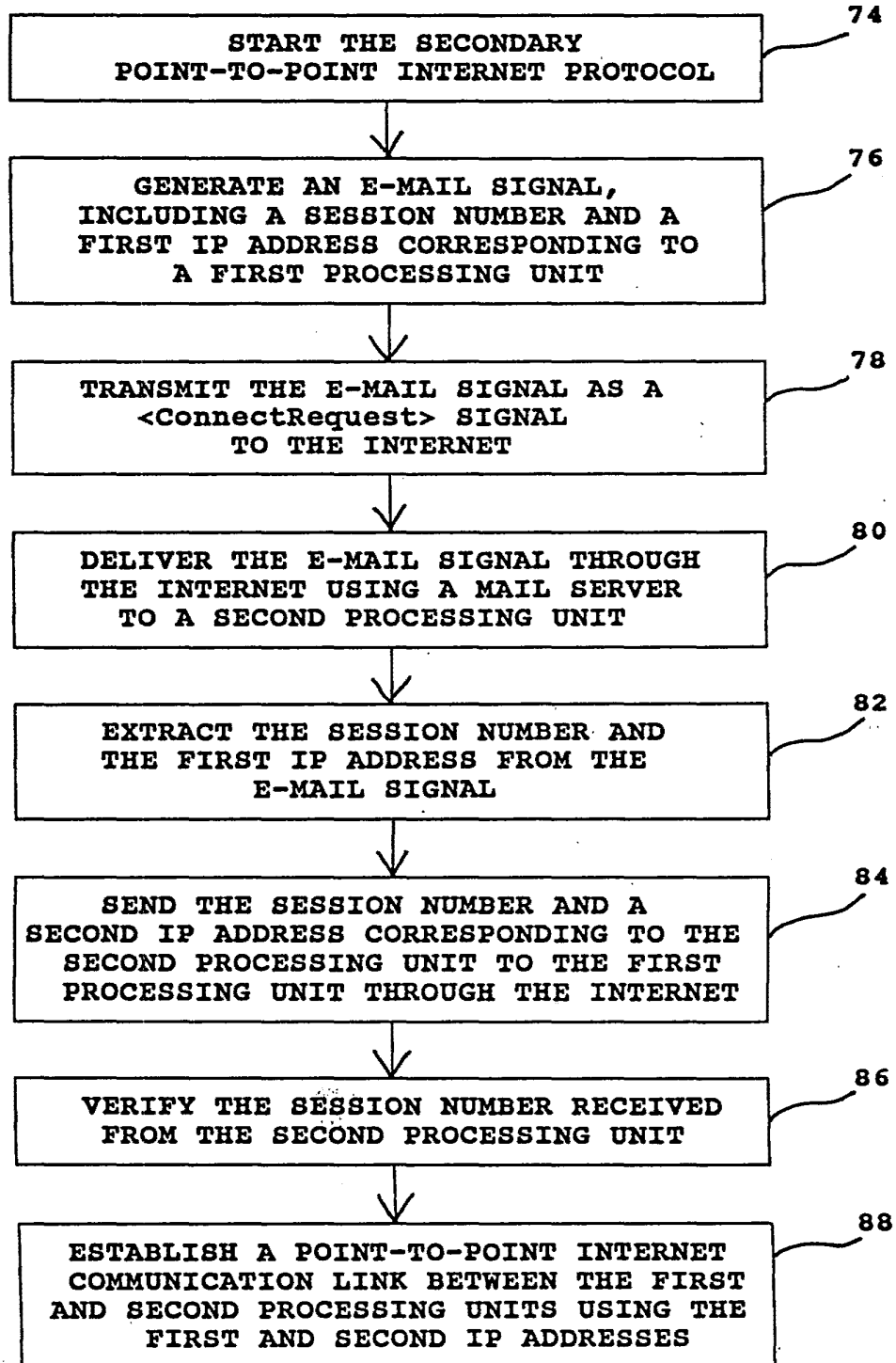
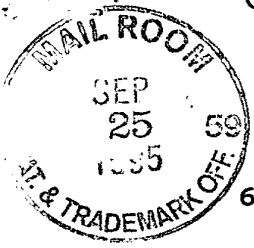


FIG. 9



649-2

479-201

08 533115 A

POINT-TO-POINT INTERNET PROTOCOL

BACKGROUND OF THE INVENTION

1. Field of the Invention

5 This disclosure relates to network communication protocols, and in particular to a point-to-point protocol for use with the Internet.

2. Description of the Related Art

10 The increased popularity of on-line services such as AMERICA ONLINE™, COMPUSERVE®, and other services such as Internet gateways have spurred applications to provide multimedia, including video and voice clips, to online users. An example of an online voice clip application is VOICE E-MAIL FOR WINCIM and VOICE E-MAIL FOR AMERICA ONLINE™, available from Bonzi Software, as described in  
15 "Simple Utilities Send Voice E-Mail Online", MULTIMEDIA WORLD, VOL. 2, NO. 9, August 1995, p. 52. Using such Voice E-Mail software, a user may create an audio message to be sent to a predetermined E-mail address specified by the user.

B 20 Generally, devices interfacing <sup>to</sup> the Internet and other online services may communicate with each other upon establishing respective device addresses. One type of device address is the Internet Protocol (IP) address, which acts as a pointer to the device associated with the IP

2

649-2

address. A typical device may have a Serial Line Internet Protocol or Point-to-Point Protocol (SLIP/PPP) account with a permanent IP address for receiving e-mail, voicemail, and the like over the Internet. E-mail and voicemail is  
5 generally intended to convey text, audio, etc., with any routing information such as an IP address and routing headers generally being considered an artifact of the communication, or even gibberish to the recipient.

Devices such as a host computer or server of a  
10 company may include multiple modems for connection of users to the Internet, with a temporary IP address allocated to each user. For example, the host computer may have a general IP address "XXX.XXX.XXX.XXX", and each user may be allocated a successive IP address of <sup>XXX.XXX.XXX.10</sup> ~~XXX.XXX.XXX.XXX.10~~,  
~~XXX.XXX.XXX.11~~ <sup>XXX.XXX.XXX.11</sup> ~~XXX.XXX.XXX.XXX.11~~, <sup>XXX.XXX.XXX.12</sup> ~~XXX.XXX.XXX.XXX.12~~, etc. Such temporary  
15 ~~XXX.XXX.XXX.XXX.11~~, ~~XXX.XXX.XXX.XXX.12~~, etc. Such temporary IP addresses may be reassigned or recycled to the users, for example, as each user is successively connected to an outside party. For example, a host computer of a company may support a maximum of 254 IP addresses which are pooled  
20 and shared between devices connected to the host computer.

Permanent IP addresses of users and devices accessing the Internet readily support point-to-point communications of voice and video signals over the Internet. For example, realtime video teleconferencing has been  
25 implemented using dedicated IP addresses and mechanisms

649-2

known as reflectors. Due to the dynamic nature of temporary IP addresses of some devices accessing the Internet, point-to-point communications in realtime of voice and video have been generally difficult to attain.

5 SUMMARY OF THE INVENTION

A point-to-point Internet protocol is disclosed which exchanges Internet Protocol (IP) addresses between processing units to establish a point-to-point communication link between the processing units through the Internet.

10 A first point-to-point Internet protocol is disclosed which includes the steps of:

(a) storing in a database a respective IP address of a set of processing units that have an on-line status with respect to the Internet;

15 (b) transmitting a query from a first processing unit to a connection server to determine the on-line status of a second processing unit; and

(c) retrieving the IP address of the second unit from the database using the connection server, in response to the determination of a positive on-line status of the second processing unit, for establishing a point-to-point communication link between the first and second processing units through the Internet.

20

649-2

A second point-to-point Internet protocol is disclosed, which includes the steps of:

(a) transmitting an E-mail signal, including a first IP address, from a first processing unit;

5 (b) processing the E-mail signal through the Internet to deliver the E-mail signal to a second processing unit; and

(c) transmitting a second IP address to the first processing unit for establishing a point-to-point  
10 communication link between the first and second processing units through the Internet.

BRIEF DESCRIPTION OF THE DRAWINGS

The features of the disclosed point-to-point Internet protocol and system will become more readily  
15 apparent and may be better understood by referring to the following detailed description of an illustrative embodiment of the present invention, taken in conjunction with the accompanying drawings, where:

FIG. 1 illustrates, in block diagram format, a  
20 system for the disclosed point-to-point Internet protocol;

FIG. 2 illustrates, in block diagram format, the system using a secondary point-to-point Internet protocol;

FIG. 3 illustrates, in block diagram format, the system of FIGS. 1-2 with the point-to-point Internet  
25 protocol established;



649-2

FIG. 4 is another block diagram of the system of FIGS. 1-2 with audio communications being conducted;

FIG. 5 illustrates a display screen for a processing unit;

5 FIG. 6 illustrates another display screen for a processing unit;

FIG. 7 illustrates a flowchart of the initiation of the point-to-point Internet protocols;

FIG. 8 illustrates a flowchart of the performance of the primary point-to-point Internet protocols; and

FIG. 9 illustrates a flowchart of the performance of the secondary point-to-point Internet protocol.

#### DESCRIPTION OF THE PREFERRED EMBODIMENTS

Referring now in specific detail to the drawings, with like reference numerals identifying similar or identical elements, as shown in FIG. 1, the present disclosure describes a point-to-point Internet protocol and system 10 for using such a protocol.

In an exemplary embodiment, the system 10 includes a first processing unit 12 for sending at least a voice signal from a first user to a second user. The first processing unit 12 includes a processor 14, a memory 16, an input device 18, and an output device 20. The output device 20 includes at least one modem capable of, for example, 14.4 kbaud communications and operatively connected via wired

649-2

and/or wireless communication connections to the Internet. One skilled in the art would understand that the input device 18 may be implemented at least in part by the modem of the output device 20 to allow input signals from the communication connections to be received. The second processing unit 22 may have a processor, memory, and input and output devices, including at least one modem and associated communication connections, as described above for the first processing unit 12. In an exemplary embodiment, each of the processing units 12, 22 may be a WEBPHONE™ unit, available from ~~INTERNET TELEPHONE COMPANY~~, capable of operating the disclosed point-to-point Internet protocol and system 10, as described herein.

*UNA*

10

The first processing unit 12 and the second processing unit 22 are operatively connected to the Internet 24 by communication devices and software known in the art. The processing units 12, 22 <sup>may be</sup> ~~are~~ operatively interconnected through the Internet 24 <sup>to</sup> ~~by~~ a connection server 26, and may also be operatively connected to a mail server 28 associated with the Internet 24.

*A*

*B*

20

The connection server 26 includes a processor 30, a timer 32 for generating timestamps, and a memory such as a database 34 for storing, for example, E-mail and Internet Protocol (IP) addresses of logged-in units. In an exemplary

*7*

649-2

A  
embodiment, the connection server 26 may be a SPARC 5 server  
or a SPARC 20 server, available from SUN MICROSYSTEMS, INC.,<sup>1</sup>

having a central processing unit (CPU) as processor 30  
operating an operating system (OS) such as UNIX and

B  
5 providing timing operations such as maintaining the timer  
32, a hard drive or fixed drive as well as dynamic <sup>random access</sup> ~~read-only~~  
memory (DRAM) for storing the database 34, and a keyboard  
and display and/or other input and output devices (not shown  
in FIG. 1). The database 34 may be an SQL database  
10 available from ORACLE or INFOMIX.

B  
In an exemplary embodiment, the mail server 28 may  
be a Post Office Protocol (POP) Version 3 mail server  
including a processor, memory, and stored programs operating  
in a UNIX environment, or alternatively <sup>another</sup> ~~other~~ OS, to process  
15 E-mail capabilities between processing units and devices  
over the Internet 24.

A  
The first processing unit 12 may operate the  
disclosed point-to-point Internet protocol by a computer  
program described hereinbelow in conjunction with FIG. 6,  
20 which <sup>may be</sup> ~~are~~ implemented from compiled and/or interpreted  
source code in the C++ programming language and which may be  
downloaded to the first processing unit 12 from an external  
computer. The operating computer program may be stored in  
the memory 16, which may include about 8 MB RAM and/or a  
25 hard or fixed drive having about 8 MB. Alternatively, the

649-2

source code may be implemented in the first processing unit 12 as firmware, as an erasable read only memory (EPROM), etc. It is understood that one skilled in the art would be able to use programming languages other than C++ to  
5 implement the disclosed point-to-point Internet protocol and system 10.

The processor 14 receives input commands and data from a first user associated with the first processing unit 12 through the input device 18, which may be an input port  
10 connected by a wired, optical, or a wireless connection for electromagnetic transmissions, or alternatively may be transferable storage media, such as floppy disks, magnetic tapes, compact disks, or other storage media including the input data from the first user.

The input device 18 may include a user interface (not shown) having, for example, at least one button actuated by the user to input commands to select from a plurality of operating modes to operate the first processing unit 12. In alternative embodiments, the input device 18  
20 may include a keyboard, a mouse, a touch screen, and/or a data reading device such as a disk drive for receiving the input data from input data files stored in storage media such as a floppy disk or, for example, an 8 mm storage tape. The input device 18 may alternatively include connections to

649-2

other computer systems to receive the input commands and data therefrom.

A

The first processing unit 12 may include a visual interface as the output device 20 for use in conjunction with the input device 18 and embodied as one of the screens illustrated by the examples shown in FIGS. <sup>5-6</sup>~~4-5~~ and discussed below. It is also understood that alternative input devices may be used in conjunction with alternative output devices to receive commands and data from the user, such as

10 keyboards, mouse devices, and graphical user interfaces (GUI) such as WINDOWS<sup>TM</sup> 3.1 available from MICROSOFT<sup>TM</sup> Corporation, <sup>Redmond, WA,</sup> executed by the processor 14 using, for example, DOS 5.0. One skilled in the art would understand that other operating systems and GUIs, such as OS/2 and OS/2 WARP,

A

15 available from IBM CORPORATION, <sup>Boca Raton, FL</sup> may be used. Other alternative input devices may include microphones and/or telephone handsets for receiving audio voice data and commands, with the first processing unit 12 including speech or voice recognition devices, dual tone multi-frequency

20 (DTMF) based devices, and/or software known in the art to accept voice data and commands and to operate the first processing unit 12.

In addition, either of the first processing unit 12 and the second processing unit 22 may be implemented in a

649-2

personal digital assistant (PDA) providing modem and E-mail capabilities and Internet access, with the PDA providing the input/output screens for mouse interaction or for touchscreen activation as shown, for example, in FIGS. 4-5, as a combination of the input device 18 and output device 20.

For clarity of explanation, the illustrative embodiment of the disclosed point-to-point Internet protocol and system 10 is presented as having individual functional blocks, which may include functional blocks labelled as "processor" and "processing unit". The functions represented by these blocks may be provided through the use of either shared or dedicated hardware, including, but not limited to, hardware capable of executing software. For example, the functions of each of the processors and processing units presented herein may be provided by a shared processor or by a plurality of individual processors. Moreover, the use of the functional blocks with accompanying labels herein is not to be construed to refer exclusively to hardware capable of executing software. Illustrative embodiments may include digital signal processor (DSP) hardware, such as the AT&T DSP16 or DSP32C, read-only memory (ROM) for storing software performing the operations discussed below, and random access memory (RAM) for storing DSP results. Very large scale integration (VLSI) hardware

649-2

embodiments, as well as custom VLSI circuitry in combination with a general purpose DSP circuit, may also be provided. Any and all of these embodiments may be deemed to fall within the meaning of the labels for the functional blocks as used herein.

The processing units 12, 22 are capable of placing calls and connecting to other processing units connected to the Internet 24, for example, via dialup SLIP/PPP lines. In an exemplary embodiment, each processing unit assigns an unsigned long session number, for example, a <sup>32-bit</sup>  $2^{32}$  bit long sequence in a \*.ini file for each call. Each call may be assigned a successive session number in sequence, which may be used by the respective processing unit to associate the call with one of the SLIP/PPP lines, to associate a <ConnectOK> response signal with a <ConnectRequest> signal, and to allow for multiplexing and demultiplexing of inbound and outbound conversations on conference lines.

For callee (or called) processing units with fixed IP addresses, the caller (or calling) processing unit may open a "socket", i.e. a file handle or address indicating where data is to be sent, and transmit a <Call> command to establish communication with the callee utilizing, for example, datagram services such as Internet Standard network layering as well as transport layering, which may include a

649-2

Transport Control Protocol (TCP) or a User Datagram Protocol (UDP) on top of the IP. Typically, a processing unit having a fixed IP address may maintain at least one open socket and a called processing unit waits for a <Call> command to  
5 assign the open socket to the incoming signal. If all lines are in use, the callee processing unit sends a BUSY signal or message to the caller processing unit.

As shown in FIG. 1, the disclosed point-to-point Internet protocol and system 10 operate when a callee  
10 processing unit does not have a fixed or predetermined IP address. In the exemplary embodiment and without loss of generality, the first processing unit 12 is the caller processing unit and the second processing unit 22 is the called processing unit.

15 When either of processing units 12, 22 logs on to the Internet via a dial-up connection, the respective unit is provided a dynamically allocated IP address by the  
connection server 26.

20 Upon the first user initiating the point-to-point Internet protocol when the first user is logged on to the Internet 24, the first processing unit 12 automatically transmits its associated E-mail address and its dynamically allocated IP address to the connection server 26. The connection server 26 then stores these addresses in the  
25 database 34 and timestamps the stored addresses using timer



649-2

32. The first user operating the first processing unit 12 is thus established in the database 34 as an active on-line party available for communication using the disclosed point-to-point Internet protocol. Similarly, a second user  
5 operating the second processing unit 22, upon connection to the Internet 24 through <sup>a</sup>~~the~~ connection <sup>service provider</sup> server 26, is processed by the connection server 26 to be established in the database 34 as an active on-line party.

B  
The connection server 26 may use the timestamps to  
10 update the status of each processing unit; for example, after 2 hours, so that the on-line status information stored in the database 34 is relatively current. Other predetermined time periods, such as a default value of 24 hours, may be configured by a systems operator.

15 The first user with the first processing unit 12 initiates a call using, for example, a Send command and/or a command to speeddial an N<sup>TH</sup> stored number, which may be labelled [SND] and [SPD][N], respectively, by the input device 18 and/or the output device 20, such as shown in  
20 FIGS. 5-6. In response to either the Send or speeddial commands, the first processing unit 12 retrieves from memory 16 a stored E-mail address of the callee corresponding to the N<sup>TH</sup> stored number. Alternatively, the first user may directly enter the E-mail address of the callee.

649-2

The first processing unit 12 then sends a query, including the E-mail address of the callee, to the connection server 26. The connection server 26 then searches the database 34 to determine whether the callee is logged-in by finding any stored information corresponding to the callee's E-mail address indicating that the callee is active and on-line. If the callee is active and on-line, the connection server 26 then performs the primary point-to-point Internet protocol; i.e. the IP address of the callee is retrieved from the database 34 and sent to the first processing unit 12. The first processing unit 12 may then directly establish the point-to-point Internet communications with the callee using the IP address of the callee.

If the callee is not on-line when the connection server 26 determines the callee's status, the connection server 26 sends an OFF-LINE signal or message to the first processing unit 12. The first processing unit 12 may also display a message such as "Called Party Off-Line" to the first user.

When a user logs off or goes off-line from the Internet 24, the connection server 26 updates the status of the user in the database 34; for example, by removing the user's information, or by flagging the user as being off-line. The connection server 26 may be instructed to update

649-2

the user's information in the database 34 by an off-line message, such as a data packet, sent automatically from the processing unit of the user prior to being disconnected from the connection server 26. Accordingly, an off-line user is effectively disabled from making and/or receiving point-to-point Internet communications.

As shown in FIGS. 2-4, the disclosed secondary point-to-point Internet protocol may be used as an alternative to the primary point-to-point Internet protocol described above, for example, if the connection server 26 is non-responsive, inoperative, and/or unable to perform the primary point-to-point Internet protocol, as a non-responsive condition. Alternatively, the disclosed secondary point-to-point Internet protocol may be used independent of the primary point-to-point Internet protocol. In the disclosed secondary point-to-point Internet protocol, the first processing unit 12 sends a <ConnectRequest> message via E-mail over the Internet 24 to the mail server 28. The E-mail including the <ConnectRequest> message may have, for example, the subject

[\*wp#XXXXXXXX#nnn.nnn.nnn.nnn#emailAddr]

where nnn.nnn.nnn.nnn is the current (i.e. temporary or permanent) IP address of the first user, and XXXXXXXX is a session number, which may be unique and associated with the

649-2

request of the first user to initiate point-to-point communication with the second user.

As described above, the first processing unit 12 may send the <ConnectRequest> message in response to an unsuccessful attempt to perform the primary point-to-point Internet protocol. Alternatively, the first processing unit 12 may send the <ConnectRequest> message in response to the first user initiating a SEND command or the like.

After the <ConnectRequest> message via E-mail is sent, the first processing unit 12 opens a socket and waits to detect a response from the second processing unit 22. A timeout timer, such as timer 32, may be set by the first processing unit 12, in a manner known in the art, to wait for a predetermined duration to receive a <ConnectOK> signal. The processor 14 of the first processing unit 12 may cause the output device 20 to output a Ring signal to the user, such as an audible ringing sound, about every 3 seconds. For example, the processor 14 may output a \*.wav file, which may be labelled RING.WAV, which is processed by the output device 20 to output an audible ringing sound.

The mail server 28 then polls the second processing unit 22, for example, every 3-5 seconds, to deliver the E-mail. Generally, the second processing unit 22 checks the incoming lines, for example, at regular



649-2

intervals to wait for and to detect incoming E-mail from the mail server 28 through the Internet 24.

Typically, for sending E-mail to users having associated processing units operatively connected to a host computer or server operating an Internet gateway, E-Mail for  
5 a specific user may be sent over the Internet 24 and directed to the permanent IP address or the SLIP/PPP account designation of the host computer, which then assigns a temporary IP address to the processing unit of the specified  
10 user for properly routing the E-mail. The E-mail signal may include a name or other designation such as a username which identifies the specific user regardless of the processing unit assigned to the user; that is, the host computer may track and store the specific device where a specific user is  
15 assigned or logged on, independent of the IP address system, and so the host computer may switch the E-mail signal to the device of the specific user. At that time, a temporary IP address may be generated or assigned to the specific user and device.

20 Upon detecting and/or receiving the incoming E-mail signal from the first processing unit 12, the second processing unit 22 may assign or may be assigned a temporary IP address. Therefore, the delivery of the E-mail through the Internet 24 provides the second processing unit 22 with

649-2

a session number as well as IP addresses of both the first processing unit 12 and the second processing unit 22.

Point-to-point communication may then be established by the processing units 12, 22. For example, the second processing unit 22 may process the E-mail signal to extract the <ConnectRequest> message, including the IP address of the first processing unit 12 and the session number. The second processing unit 22 may then open a socket and generate a <ConnectOK> response signal, which includes the temporary IP address of the second processing unit 22 as well as the session number.

The second processing unit 22 sends the <ConnectOK> signal directly over the Internet 24 to the IP address of the first processing unit 12 without processing by the mail server 28, and a timeout timer of the second processing unit 22 may be set to wait and detect a <Call> signal expected from the first processing unit 12.

Realtime point-to-point communication of audio signals over the Internet 24, as well as video and voicemail, may thus be established and supported without requiring permanent IP addresses to be assigned to either of the users or processing units 12, 22. For the duration of the realtime point-to-point link, the relative permanence of the current IP addresses of the processing units 12, 22 is sufficient, whether the current IP addresses were permanent

649-2

(i.e. predetermined or preassigned) or temporary (i.e. assigned upon initiation of the point-to-point communication).

In the exemplary embodiment, a first user  
5 operating the first processing unit 12 is not required to be notified by the first processing unit 12 that an E-mail is being generated and sent to establish the point-to-point link with the second user at the second processing unit 22. Similarly, the second user is not required to be notified by  
10 the second processing unit 22 that an E-mail has been received and/or a temporary IP address is associated with the second processing unit 22. The processing units 12, 22 may perform the disclosed point to-point Internet protocol automatically upon initiation of the <sup>point-to-point</sup>~~point-to-point~~  
15 communication command by the first user without displaying the E-mail interactions to either user. Accordingly, the disclosed point-to-point Internet protocol may be transparent to the users. Alternatively, either of the first and second users may receive, for example, a brief  
20 message of "CONNECTION IN PROGRESS" or the like on a display of the respective output device of the processing units 12, 22.

After the initiation of either the primary or the secondary point-to-point Internet protocols described above  
25 in conjunction with FIGS. 1-2, the point-to-point

649-2

communication link over the Internet 24 may be established as shown in FIGS. 3-4 in a manner known in the art. For example, referring to FIG. 3, upon receiving the <ConnectOK> signal from the second processing unit 22, the first  
5 processing unit 12 extracts the IP address of the second processing unit 22 and the session number, and the session number sent from the second processing unit 22 is then checked with the session number originally sent from the first processing unit 12 in the <ConnectRequest> message as  
10 E-mail. If the session numbers sent and received by the processing unit 12 match, then the first processing unit 12 sends a <Call> signal directly over the Internet 24 to the second processing unit 22; i.e. using the IP address of the second processing unit 22 provided to the first processing  
15 unit 12 in the <ConnectOK> signal.

Upon receiving the <Call> signal, the second processing unit 22 may then begin a ring sequence, for example, by indicating or annunciating to the second user that an incoming call is being received. For example, the  
20 word "CALL" may be displayed on the output device of the second processing unit 22. The second user may then activate the second processing unit 22 to receive the incoming call.

Referring to FIG. 4, after the second processing  
25 unit 22 receives the incoming call, realtime audio and/or



649-2

video conversations may be conducted in a manner known in the art between the first and second users through the Internet 24, for example, by compressed digital audio signals. Each of the processing units 12, 22 may also display to each respective user the words "IN USE" to indicate that the point-to-point communication link is established and audio or video signals are being transmitted.

In addition, either user may terminate the point-to-point communication link by, for example, activating a termination command, such as by activating an [END] button or icon on a respective processing unit, causing the respective processing unit to send an <End> signal which causes both processing units to terminate the respective sockets, as well as to perform other cleanup commands and functions known in the art.

FIGS. 5-6 illustrate examples of display screens 36 which may be output by a respective output device of each processing unit 12, 22 of FIGS. 1-4 for providing the disclosed point-to-point Internet protocol and system 10. Such display screens may be displayed on a display of a personal computer (PC) or a PDA in a manner known in the art.

As shown in FIG. 5, a first display screen 36 includes a status area 38 for indicating, for example, a

649-2

called user by name and/or by IP address or telephone  
number; a current function such as C2; a current time; a  
current operating status such as "IN USE", and other control  
icons such as a down arrow icon 40 for scrolling down a list  
5 of parties on a current conference line. The operating  
status may include such annunciators as "IN USE", "IDLE",  
"BUSY", "NO ANSWER", "OFFLINE", "CALL", "DIALING",  
"MESSAGES", and "SPEEDDIAL".

Other areas of the display screen 36 may include  
10 activation areas or icons for actuating commands or entering  
data. For example, the display screen 36 may include a set  
of icons 42 arranged in columns and rows including digits 0-  
9 and commands such as END, SND, HLD, etc. For example, the  
END and SND commands may be initiated as described above,  
15 and the HLD icon 44 may be actuated to place a current line  
on hold. Such icons may also be configured to substantially  
simulate a telephone handset or a cellular telephone  
interface to facilitate ease of use, as well as to simulate  
function keys of a keyboard. For example, icons labelled  
20 L1-L4 may be mapped to function keys F1-F4 on standard PC  
keyboards, and icons C1-C3 may be mapped to perform as  
combinations of function keys, such as CTRL-F1, CTRL-F2, and  
CTRL-F3, respectively. In addition, the icons labelled L1-  
L4 and C1-C3 may include circular regions which may simulate  
25 light emitting diodes (LEDs) which indicate that the

649-2

function or element represented by the respective icon is active or being performed.

Icons L1-L4 may represent each of 4 lines available to the caller, and icons C1-C3 may represent conference calls using at least one line to connect, for example, two or more parties in a conference call. The icons L1-L4 and C1-C3 may indicate the activity of each respective line or conference line. For example, as illustrated in FIG. 5, icons L1-L2 may have lightly shaded or colored circles, such as a green circle, indicating that each of lines 1 and 2 are in use, while icons L3-L4 may have darkly shaded or color circles, such as a red or black circle, indicating that each of lines 3 and 4 are not in use. Similarly, the lightly shaded circle of the icon labelled C2 indicates that the function corresponding to C2 is active, as additionally indicated in the status area 38, while darkly shaded circles of icons labelled C1 and C3 indicate that such corresponding functions are not active.

The icons 42 are used in conjunction with the status area 38. For example, using a mouse for input, a line that is in use as indicated by the lightly colored circle of the icon may be activated to indicate a party's name by clicking a right mouse button for 5 seconds until another mouse click is actuated or the [ESC] key or icon is

649-2

actuated. Thus, the user may switch between multiple calls in progress on respective lines.

Using the icons as well as an input device such as a mouse, a user may enter the name or alias or IP address, if known, of a party to be called by either manually entering the name, by using the speedial feature, or by double clicking on an entry in a directory stored in the memory, such as the memory 16 of the first processing unit 12, where the directory entries may be scrolled using the status area 38 and the down arrow icon 40.

Once a called party is listed in the status area 38 as being active on a line, the user may transfer the called party to another line or a conference line by clicking and dragging the status area 38, which is represented by a reduced icon 46. Dragging the reduced icon 46 to any one of line icons L1-L4 transfers the called party in use to the selected line, and dragging the reduced icon 46 to any one of conference line icons C1-C3 adds the called party to the selected conference call.

Other features may be supported, such as icons 48-52, where icon 48 corresponds to, for example, an ALT-X command to exit the communication facility of a processing unit, and icon 50 corresponds to, for example, an ALT-M command to minimize or maximize the display screen 36 by the output device of the processing unit. Icon 52 corresponds

25

649-2

to an OPEN command, which may, for example, correspond to pressing the O key on a keyboard, to expand or contract the display screen 36 to represent the opening and closing of a cellular telephone. An "opened" configuration is shown in FIG. 5, and a "closed" configuration is shown in FIG. 6. In the "opened" configuration, additional features such as output volume (VOL) controls, input microphone (MIC) controls, waveform (WAV) sound controls, etc.

The use of display screens such as those shown in FIGS. 5-6 provided flexibility in implementing various features available to the user. It is to be understood that additional features such as those known in the art may be supported by the processing units 12, 22.

Alternatively, it is to be understood that one skilled in the art may implement the processing units 12, 22 to have the features of the display screens in FIGS. 5-6 in hardware; i.e. a wired telephone or wireless cellular telephone may include various keys, LEDs, liquid crystal displays (LCDs), and touchscreen actuators corresponding to the icons and features shown in FIGS. 5-6. In addition, a PC may have the keys of a keyboard and mouse mapped to the icons and features shown in FIGS. 5-6.

Referring to FIG. 7, the disclosed point-to-point Internet protocol and system 10 is initiated at a first processing unit 12 for point-to-point Internet

649-2

communications by starting the point-to-point Internet protocols in step 54; initiating the primary point-to-point Internet protocol in step 56 by sending a query from the first processing unit 12 to the connection server 26;

5 determining if the connection server 26 is operative to perform the point-to-point Internet protocol in step 58 by receiving, at the first processing unit 12, an on-line status signal from the connection server 26, which may include the IP address of the callee or a "Callee Off-Line"

10 message; performing the primary point-to-point Internet protocol in step 60, which may include receiving, at the first processing unit 12, the IP address of the callee if the callee is active and on-line; and initiating and performing the secondary point-to-point Internet protocol in

15 step 62 if the called party is not active and/or on-line.

Referring to FIG. 8 in conjunction with FIGS. 1 and 3-4, the disclosed point-to-point Internet protocol and system 10 operates using the connection server 26 to perform step 60 in FIG. 7 by starting the point-to-point Internet

20 protocol in step 64; timestamping and storing E-mail and IP addresses of logged-in users and processing units in the database 34 in step 66; receiving a query at the connection server 26 from a first processing unit 12 in step 68 to determine whether a second user or second processing unit 22

25 is logged-in to the Internet 24, with the second user being

649-2

specified, for example, by an E-mail address; retrieving the IP address of the specified user from the database 34 in step 70 if the specified user is logged-in to the Internet; and sending the retrieved IP address to the first processing unit in step 72 to establish point-to-point Internet communications with the specified user.

Referring to FIG. 9 in conjunction with FIGS. 2-4, the disclosed secondary point-to-point Internet protocol and system 10 operates at the first processing unit 12 to perform step 62 of FIG. 7. The disclosed secondary point-to-point Internet protocol operates as shown in FIG. 9 by starting the secondary point-to-point Internet protocol in step 74; generating an E-mail signal, including a session number and a first IP address corresponding to a first processing unit in step 76 using the first processing unit 12; transmitting the E-mail signal as a <ConnectRequest> signal to the Internet 24 in step 78; delivering the E-mail signal through the Internet 24 using a mail server 28 to a second processing unit 22 in step 80; extracting the session number and the first IP address from the E-mail signal in step 82; transmitting or sending the session number and a second IP address corresponding to the second processing unit 22 to the first processing unit 12 through the Internet 24 in step 84; verifying the session number received from the second processing unit 22 in step 86; and establishing a

649-2

point-to-point Internet communication link between the first processing unit 12 and second processing unit 22 using the first and second IP addresses in step 88.

5 While the disclosed point-to-point Internet protocols and system have been particularly shown and described with reference to the preferred embodiments, it is understood by those skilled in the art that various modifications in form and detail may be made therein without departing from the scope and spirit of the invention.

10 Accordingly, modifications such as those suggested above, but not limited thereto, are to be considered within the scope of the invention.



08/533118

649-2

WHAT IS CLAIMED IS:

1. A method for establishing point-to-point Internet communication comprising the steps of:

5 (a) storing in a database a respective Internet Protocol (IP) address of a set of processing units that have an on-line status with respect to the Internet;

(b) transmitting a query from a first processing unit to a connection server to determine the on-line status of a second processing unit; and

10 (c) retrieving the IP address of the second unit from the database using the connection server, in response to the determination of a positive on-line status of the second processing unit, for establishing a point-to-point communication link between the first and second  
15 processing units through the Internet.

2. The method of claim 1 wherein the step (b) of transmitting the query includes the step of:

20 (b1) transmitting the query to the connection server operatively connected to the database and the Internet; and

wherein the step (c) of retrieving the IP address includes the steps of:

25 (c1) searching the database using the connection server;

30

(c2) determining the on-line status of the second processing unit;

(c3) retrieving the IP address of the second processing unit in response to the positive on-line status of the second processing unit; and

(c4) transmitting the IP address of the second processing unit to the first processing unit for establishing the point-to-point communication link between the first and second processing units through the Internet.

10

3. The method of claim 2 further comprising, after step (c2), the steps of:

(c5) generating an off-line message in response to a negative on-line status of the second processing unit; and

15

(c4) transmitting the off-line message to the first processing unit.

4. The method of claim 1 further comprising the step of:

20

(d) performing a secondary communication protocol in response to a non-responsive condition of the connection server.

5. The method of claim 4 wherein the step (d) of performing the secondary communication protocol includes the steps of:

(d1) transmitting an E-mail signal, including a first IP address, from the first processing unit;

(d2) processing the E-mail signal through the Internet to deliver the E-mail signal to the second processing unit; and

(d3) transmitting a second IP address to the first processing unit for establishing a point-to-point communication link between the first and second processing units through the Internet.

6. An apparatus comprising:

a first processing unit including:

a program stored in a memory for performing a point-to-point Internet protocol; and

a processor for executing the point-to-point Internet protocol program to generate a query to receive an Internet Protocol (IP) address of a second processing unit, for transmitting the query through the Internet to a connection server for determining an on-line status of a second processing unit to the connection server, and for establishing a point-to-point communication link to the second processing unit using the IP address.

7. A system for point-to-point communications over the Internet comprising:

a database for storing a set of Internet Protocol (IP) addresses of at least one processing unit that has on-line status with respect to the Internet;

a first processing unit including:

a first program for performing a first point-to-point Internet protocol; and

a first processor for executing the first program and for transmitting a query;

a connection server, responsive to the query, for determining the on-line status of a second processing unit by searching the database, and for transmitting an on-line message to the first processing unit for establishing a point-to-point communication link between the first and second processing units through the Internet.

8. The system of claim 7 wherein the connection server, responsive to a positive determination of the on-line status of the second processing unit, retrieves the respective IP address of the second processing unit from the database and transmits the on-line message, including the IP address, to the first processing unit; and

wherein the first processing unit establishes the point-to-point communication link between the first and

649-2

second processing units through the Internet in response to receiving the IP address of the second processing unit from the connection server.

5           9.    The system of claim 7 wherein the connection server, responsive to a negative determination of the on-line status of the second processing unit, generates an off-line message, and transmits the off-line message to the first processing unit.

10

10.   The system of claim 7 wherein the connection server further includes a timer for timestamping IP addresses of the set of processing units having a positive on-line status with respect to the Internet.

15

11.   The system of claim 7 further comprising:  
a mail server for processing a E-mail signal through the Internet to deliver the E-mail to a specified second processing unit for establishing a point-to-point communication link between the first and second processing units through the Internet; and

20

wherein the first processor of the first processing unit executes a second program to generate and transmit the E-mail signal, including a first IP address

649-2

associated with the first processing unit, to the mail server.

12. A method for establishing point-to-point  
5 Internet communication comprising the steps of:

(a) transmitting an E-mail signal, including  
a first Internet Protocol (IP) address, from a first  
processing unit;

(b) processing the E-mail signal through the  
10 Internet to deliver the E-mail signal to a second processing  
unit; and

(c) transmitting a second IP address to the  
first processing unit for establishing a point-to-point  
communication link between the first and second processing  
15 units through the Internet.

13. The method of claim 12 further comprising the  
step of:

(a1) generating the E-mail signal from the  
20 first IP address corresponding to the first processing unit  
before the step (a) of transmitting the E-mail signal.

649-2

14. The method of claim 12 further comprising the step of:

5 (a1) generating the E-mail signal from a session number before the step (a) of transmitting the E-mail signal.

15. The method of claim 12 wherein the step (b) of processing the E-mail signal further comprises the step of:

10 (b1) processing the E-mail signal using a mail server operatively connected to the second processing unit.

16. The method of claim 12 further comprising the step of:

15 (b1) generating a connection signal including the second IP address at the second processing unit before the step (c) of transmitting the second IP address to the first processing unit; and

20 wherein the step (c) of transmitting the second IP address includes the step (c1) of transmitting the connection signal from the second processing unit to the first processing unit.

17. An apparatus comprising:  
a first processing unit including:  
a program stored in a memory for  
performing a point-to-point Internet protocol; and  
5 a processor for executing the point-to-  
point Internet protocol program to generate an E-mail  
signal, including a first Internet Protocol (IP) address,  
and for transmitting the E-mail signal through the Internet  
to a second processing unit for establishing a point-to-  
10 point communication link to the first processing unit.

18. The apparatus of claim 17 wherein the  
processor is adapted to generate the E-mail signal from the  
first IP address corresponding to the first processing unit.

19. A system for point-to-point communications  
over the Internet comprising:  
a first processing unit including:  
a first program for performing a point-  
20 to-point Internet protocol; and  
a first processor for executing the  
first program and for transmitting an E-mail signal,  
including a first Internet Protocol (IP) address; and  
a mail server for processing the E-mail  
25 signal through the Internet to deliver the E-mail to a



649-2

second processing unit for establishing a point-to-point communication link between the first and second processing units through the Internet.

5

20. The system of claim 19 further comprising:  
the second processing unit including:

a second program for performing the point-to-point Internet protocol; and

10 a second processor for executing the second program and for receiving the E-mail signal from the mail server and for generating a connection signal, including a second IP address, for establishing the point-to-point communication link to the first processing unit.

Add A2  
add B3

ABSTRACT

A point-to-point Internet protocol exchanges Internet Protocol (IP) addresses between processing units to establish a point-to-point communication link between the processing units through the Internet. A first point-to-point Internet protocol includes the steps of (a) storing in a database a respective IP address of a set of processing units that have an on-line status with respect to the Internet; (b) transmitting a query from a first processing unit to a connection server to determine the on-line status of a second processing unit; and (c) retrieving the IP address of the second unit from the database using the connection server, in response to the determination of a positive on-line status of the second processing unit, for establishing a point-to-point communication link between the first and second processing units through the Internet. A second point-to-point Internet protocol includes the steps of (a) transmitting an E-mail signal, including a first IP address, from a first processing unit; (b) processing the E-mail signal through the Internet to deliver the E-mail signal to a second processing unit; and (c) transmitting a second IP address to the first processing unit for establishing a point-to-point communication link between the first and second processing units through the Internet.

Attorney's Docket No. 649-2

**COMBINED DECLARATION AND POWER OF ATTORNEY**(ORIGINAL, DESIGN, NATIONAL STAGE OF PCT, SUPPLEMENTAL,  
DIVISIONAL, CONTINUATION OR CIP)

As a below named inventor, I hereby declare that:

**TYPE OF DECLARATION**

This declaration is of the following type: (check one applicable item below)

- original  
 design  
 supplemental

NOTE: If the declaration is for an International Application being filed as a divisional, continuation or continuation-in-part application do not check next item; check appropriate one of last three items.

- national stage of PCT

NOTE: If one of the following 3 items apply then complete and also attach ADDED PAGES FOR DIVISIONAL, CONTINUATION OR CIP.

- divisional  
 continuation  
 continuation-in-part (CIP)

**INVENTORSHIP IDENTIFICATION**

WARNING: If the inventors are each not the inventors of all the claims an explanation of the facts, including the ownership of all the claims at the time the last claimed invention was made, should be submitted.

My residence, post office address and citizenship are as stated below next to my name, I believe I am the original, first and sole inventor (if only one name is listed below) or an original, first and joint inventor (if plural names are listed below) of the subject matter which is claimed and for which a patent is sought on the invention entitled:

**TITLE OF INVENTION****POINT-TO-POINT INTERNET PROTOCOL****SPECIFICATION IDENTIFICATION**

the specification of which: (complete (a), (b) or (c))

- (a)  is attached hereto.  
 (b)  was filed on \_\_\_\_\_ as  Serial No. 0 / \_\_\_\_\_  
 or  Express Mail No., as Serial No. not yet known  
 \_\_\_\_\_ and was amended on \_\_\_\_\_  
 \_\_\_\_\_ (if applicable).

NOTE: Amendments filed after the original papers are deposited with the PTO which contain new matter are not accorded a filing date by being referred to in the declaration. Accordingly, the amendments involved are those filed with the application papers or, in the case of a supplemental declaration, are those amendments claiming matter not encompassed in the original statement of invention or claims. See 37 C.F.R. 1.67.

- (c)  was described and claimed in PCT International Application No. \_\_\_\_\_ filed on \_\_\_\_\_  
 and as amended under PCT Article 19 on \_\_\_\_\_  
 (if any).

**ACKNOWLEDGEMENT OF REVIEW OF PAPERS AND DUTY OF CANDOR**

I hereby state that I have reviewed and understand the contents of the above identified specification, including the claims, as amended by any amendment referred to above.

I acknowledge the duty to disclose information

- which is material to patentability as defined in 37, Code of Federal Regulations, §1.56

*(also check the following items, if desired)*

- and which is material to the examination of this application, namely, information where there is a substantial likelihood that a reasonable examiner would consider it important in deciding whether to allow the application to issue as a patent, and
- In compliance with this duty there is attached an information disclosure statement in accordance with 37 C.F.R. 1.98.

**PRIORITY CLAIM (35 U.S.C. §119)**

I hereby claim foreign priority benefits under Title 35, United States Code, §119 of any foreign application(s) for patent or inventor's certificate or of any PCT international application(s) designating at least one country other than the United States of America listed below and have also identified below any foreign application(s) for patent or inventor's certificate or any PCT international application(s) designating at least one country other than the United States of America filed by me on the same subject matter having a filing date before that of the application(s) of which priority is claimed.

*(complete (d) or (e))*

- (d)  no such applications have been filed.
- (e)  such applications have been filed as follows.

NOTE: Where item (c) is entered above and the International Application which designated the U.S. itself claimed priority check item (e), enter the details below and make the priority claim.

**A. PRIOR FOREIGN/PCT APPLICATION(S) FILED WITHIN 12 MONTHS (6 MONTHS FOR DESIGN) PRIOR TO THIS APPLICATION AND ANY PRIORITY CLAIMS UNDER 35 U.S.C. §119**

COUNTRY (OR INDICATE IF PCT)	APPLICATION NUMBER	DATE OF FILING (day, month, year)	PRIORITY CLAIMED UNDER 35 U.S.C. 119
			<input type="checkbox"/> YES <input type="checkbox"/> NO
			<input type="checkbox"/> YES <input type="checkbox"/> NO
			<input type="checkbox"/> YES <input type="checkbox"/> NO
			<input type="checkbox"/> YES <input type="checkbox"/> NO
			<input type="checkbox"/> YES <input type="checkbox"/> NO

ALL FOREIGN APPLICATION(S), IF ANY FILED MORE THAN 12 MONTHS  
(6 MONTHS FOR DESIGN) PRIOR TO THIS U.S. APPLICATION

NOTE: If the application filed more than 12 months from the filing date of this application is a PCT filing forming the basis for this application entering the United States as (1) the national stage, or (2) a continuation, divisional, or continuation-in-part, then also complete ADDED PAGES TO COMBINED DECLARATION AND POWER OF ATTORNEY FOR DIVISIONAL, CONTINUATION OR CIP APPLICATION for benefit of the prior U.S. or PCT application(s) under 35 U.S.C. §120.

POWER OF ATTORNEY

I hereby appoint the following attorney(s) and/or agent(s) to prosecute this application and transact all business in the Patent and Trademark Office connected therewith. (List name and registration number)

PETER G. DILWORTH, Reg. No. 25,450; ROCCO S. BARRESE, Reg. No. 25,253;  
JOSEPH J. CATANZARO, Reg. No. 25,837; DAVID M. CARTER, Reg. No. 30,949;  
PAUL J. FARRELL, Reg. No. 33,494; PETER DELUCA, Reg. No. 32,978;  
ADRIAN T. CALDERONE, Reg. No. 31,746; GEORGE M. KAPLAN, Reg. No. 28,375;  
JEFFREY S. STEEN, Reg. No. 32,063; JOSEPH W. SCHMIDT, Reg. No. 36,920;  
RAYMOND E. FARRELL, Reg. No. 34,816; RUSSELL R. KASSNER, Reg. No. 36,183;  
FRANK CHAU, Reg. No. 34,136; SCOTT D. WOFSEY, Reg. No. 35,413;  
ANTHONY J. NATOLI, Reg. No. 36,223; MICHAEL P. DILWORTH, Reg. No. 37,311;  
RICHARD F. JAWORSKI, Reg. No. 33,515; DANIEL E. TIERNEY, Reg. No. 33,461;  
WALTER M. EGBERT, III, Reg. No. 37,317; JEAN CHUNG, Reg. No. 38,674;  
CHRISTOPHER G. TRAINOR, Reg. No. 39,517; and GLENN F. SAVIT, Reg. No. 37,437,  
each of them of DILWORTH & BARRESE, 333 Earle Ovington Boulevard, Uniondale,  
New York 11553.

SEND CORRESPONDENCE TO:

DIRECT TELEPHONE CALLS TO:  
(Name and telephone number)

JOSEPH J. CATANZARO  
DILWORTH & BARRESE  
333 Earle Ovington Boulevard  
Uniondale, New York 11553

(516) 228-8484

DECLARATION

I hereby declare that all statements made herein of my own knowledge are true and that all statements made on information and belief are believed to be true; and further that these statements were made with the knowledge that willful false statements and the like so made are punishable by fine or imprisonment, or both, under Section 1001 of Title 18 of the United States Code, and that such willful false statements may jeopardize the validity of the application or any patent issued thereon.

SIGNATURE(S)

NOTE: Carefully indicate the family (or last) name as it should appear on the filing receipt and all other documents.

Full name of sole or first inventor <sup>1-00</sup> Glenn W. Hutton

✓ Inventor's signature 

✓ Date 09-23-95 Country of Citizenship Canada

Residence Miami, Florida FL

Post Office Address 9725 Hammocks Boulevard, #206, Miami, Florida 33196

Full name of second joint inventor, if any \_\_\_\_\_

Inventor's signature \_\_\_\_\_

Date \_\_\_\_\_ Country of Citizenship \_\_\_\_\_

Residence \_\_\_\_\_

Post Office Address \_\_\_\_\_

Full name of third joint inventor, if any \_\_\_\_\_

Inventor's signature \_\_\_\_\_

Date \_\_\_\_\_ Country of Citizenship \_\_\_\_\_

Residence \_\_\_\_\_

Post Office Address \_\_\_\_\_

Full name of fourth joint inventor, if any \_\_\_\_\_

Inventor's signature \_\_\_\_\_

Date \_\_\_\_\_ Country of Citizenship \_\_\_\_\_

Residence \_\_\_\_\_

Post Office Address \_\_\_\_\_

Full name of fifth joint inventor, if any \_\_\_\_\_

Inventor's signature \_\_\_\_\_

Date \_\_\_\_\_ Country of Citizenship \_\_\_\_\_

Residence \_\_\_\_\_

Post Office Address \_\_\_\_\_

CHECK PROPER BOX(ES) FOR ANY OF THE FOLLOWING  
ADDED PAGE(S) WHICH FORM A PART OF THIS DECLARATION

- Signature for subsequent joint inventors.  
Number of pages added \_\_\_\_\_.
- Signature by administrator(trix), executor(trix) or legal  
representative for deceased or incapacitated inventor.  
Number of pages added \_\_\_\_\_.
- Signature for inventor who refuses to sign or cannot be  
reached by person authorized under 37 C.F.R. §1.47.  
Number of pages added \_\_\_\_\_.

\*\*\*

- Added pages to combined declaration and power of attorney for  
divisional, continuation, or continuation-in-part (CIP)  
application.  
Number of pages added \_\_\_\_\_.

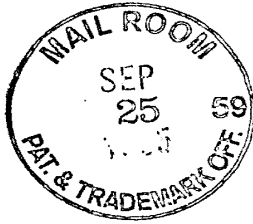
\*\*\*

- Authorization of attorney(s) to accept and follow  
instructions from representative.

\*\*\*

If no further pages form a part of this Declaration then end  
this Declaration with this page and check the following item.

- This declaration ends with this page.



Applicant or Patentee: Glenn Hutton

Serial or Patent No.: Not Yet Assigned

Filed or Issued: Concurrently Herewith

For: POINT-TO-POINT INTERNET PROTOCOL

**VERIFIED STATEMENT (DECLARATION) CLAIMING SMALL ENTITY STATUS (37 CFR 1.9(f) and 1.27(b)) - INDEPENDENT INVENTOR**

As a below named inventor, I hereby declare that I qualify as an independent inventor as defined in 37 CFR 1.9(c) for purposes of paying reduced fees under Section 41(a) and (b) of Title 35, United States Code, to the Patent and Trademark Office with regard to the invention entitled

POINT-TO-POINT INTERNET PROTOCOL

described in

- the specification filed herewith.
- application serial no. \_\_\_\_\_, filed \_\_\_\_\_.
- patent no. \_\_\_\_\_, issued \_\_\_\_\_.

I have not assigned, granted, conveyed or licensed and am under no obligation under contract or law to assign, grant, convey or license, any rights in the invention to any person who could not be classified as an independent inventor under 37 CFR 1.9(c) if that person had made the invention, or to any concern which would not qualify as a small business concern under 37 CFR 1.9(d) or a nonprofit organization under 37 CFR 1.9(e).

Each person, concern or organization to which I have assigned, granted, conveyed, or licensed or am under an obligation under contract or law to assign, convey, or license any rights in the invention is listed below:

- no such person, concern, or organization
- persons, concerns or organizations listed below\*

NOTE: Separate verified statements are required from each named person, concern or organization having rights to the invention averring to their status as small entities. (37 CFR 1.27).

FULL NAME \_\_\_\_\_

ADDRESS \_\_\_\_\_

- Individual
- Small Business Concern
- Nonprofit Organization

FULL NAME \_\_\_\_\_

ADDRESS \_\_\_\_\_

- Individual
- Small Business Concern
- Nonprofit Organization

FULL NAME \_\_\_\_\_

ADDRESS \_\_\_\_\_

- Individual
- Small Business Concern
- Nonprofit Organization

I acknowledge the duty to file, in this application or patent, notification of any change in status resulting in loss of entitlement to small entity status prior to paying, or at the time of paying, the



earliest of the issue fee or any maintenance fee due after the date on which status as a small entity is no longer appropriate. (37 CFR 1.28(b)).

I hereby declare that all statements made herein of my own knowledge are true and that all statements made on information and belief are believed to be true; and further that these statements were made with the knowledge that willful false statements and the like so made are punishable by fine or imprisonment, or both, under Section 1001 of Title 18 of the United States Code, and that such willful false statements may jeopardize the validity of the application, any patent issuing thereon, or any patent to which this verified statement is directed.

Glenn Hutton  
Name of inventor

✓   
Signature of inventor

✓ Date 09-23-95

\_\_\_\_\_  
Name of inventor

\_\_\_\_\_  
Signature of inventor

Date \_\_\_\_\_

\_\_\_\_\_  
Name of inventor

\_\_\_\_\_  
Signature of inventor

Date \_\_\_\_\_

BAR CODE LABEL



# U.S. PATENT APPLICATION

SERIAL NUMBER

08/533,115

FILING DATE

09/25/95

CLASS

395

GROUP ART UNIT

2305

APPLICANT

GLENN W. HUTTON, MIAMI, FL.

\*\*CONTINUING DATA\*\*\*\*\*  
VERIFIED

\*\*FOREIGN/PCT APPLICATIONS\*\*\*\*\*  
VERIFIED

FOREIGN FILING LICENSE GRANTED 10/17/95

\*\*\*\*\* SMALL ENTITY \*\*\*\*\*

STATE OR COUNTRY

FL

SHEETS DRAWING

6

TOTAL CLAIMS

20

INDEPENDENT CLAIMS

6

FILING FEE RECEIVED

\$479.00

ATTORNEY DOCKET NO.

649-2

ADDRESS

JOSEPH J CATANZARO  
DILWORTH & BARRESE  
333 EARLE OVINGTON BLVD  
UNIONDALE NY 11553

TITLE

POINT-TO-POINT INTERNET PROTOCOL

This is to certify that annexed hereto is a true copy from the records of the United States Patent and Trademark Office of the application which is identified above.

By authority of the  
COMMISSIONER OF PATENTS AND TRADEMARKS

Date

Certifying Officer



Bib Data Sheet



**UNITED STATES DEPARTMENT OF COMMERCE  
Patent and Trademark Office**

Address: COMMISSIONER OF PATENTS AND TRADEMARKS  
Washington, D.C. 20231

<b>SERIAL NUMBER</b> 08/533,115	<b>FILING DATE</b> 09/25/1995 <b>RULE</b> -	<b>CLASS</b> 709	<b>GROUP ART UNIT</b> 2756	<b>ATTORNEY DOCKET NO.</b> 649-2
------------------------------------	---	---------------------	-------------------------------	-------------------------------------

**APPLICANTS**  
GLENN W. HUTTON, MIAMI, FL ;  
SHANE D. MATTAWAY, BOCA RATON, FL ;  
CRAIG B. STRICKLAND, TAMARAC, FL ;

**\*\* CONTINUING DATA \*\*\*\*\***

**\*\* FOREIGN APPLICATIONS \*\*\*\*\***

**IF REQUIRED, FOREIGN FILING LICENSE GRANTED \*\* SMALL ENTITY \*\***  
\*\* 10/17/1995

Foreign Priority claimed <input type="checkbox"/> yes <input type="checkbox"/> no	<b>STATE OR COUNTRY</b> FL	<b>SHEETS DRAWING</b> 6	<b>TOTAL CLAIMS</b> 20	<b>INDEPENDENT CLAIMS</b> 6
35 USC 119 (a-d) conditions met <input type="checkbox"/> yes <input type="checkbox"/> no <input type="checkbox"/> Met after Allowance				
Verified and Acknowledged	Examiner's Signature _____	Initials _____		

**ADDRESS**  
21127

**TITLE**  
POINT-TO-POINT INTERNET PROTOCOL

<b>FILING FEE RECEIVED</b> 2125	FEES: Authority has been given in Paper No. _____ to charge/credit DEPOSIT ACCOUNT No. _____ for following:	<input type="checkbox"/> All Fees
		<input type="checkbox"/> 1.16 Fees ( Filing )
		<input type="checkbox"/> 1.17 Fees ( Processing Ext. of time )
		<input type="checkbox"/> 1.18 Fees ( Issue )
		<input type="checkbox"/> Other _____
		<input type="checkbox"/> Credit

PATENT APPLICATION SERIAL NO. 08 533115

U.S. DEPARTMENT OF COMMERCE  
PATENT AND TRADEMARK OFFICE  
FEE RECORD SHEET

280 MM 10/17/95 08533115 1 201 479.00 CK 649-2

PTO-1556  
(5/87)

# PATENT APPLICATION FEE DETERMINATION RECORD

Effective October 1, 1994

Application or Docket Number

533115

## CLAIMS AS FILED - PART I

	(Column 1) NUMBER FILED	(Column 2) NUMBER EXTRA
BASIC FEE		
TOTAL CLAIMS	20 minus 20 = *	
INDEPENDENT CLAIMS	6 minus 3 = * 3	
MULTIPLE DEPENDENT CLAIM PRESENT		

SMALL ENTITY		OR	OTHER THAN SMALL ENTITY	
RATE	FEE		RATE	FEE
	365.00	OR		730.00
x\$11=		OR	x\$22=	
x38=	114-	OR	x76=	
+120=		OR	+240=	
TOTAL	479-	OR	TOTAL	

\* If the difference in column 1 is less than zero, enter "0" in column 2

## CLAIMS AS AMENDED - PART II

		(Column 1) CLAIMS REMAINING AFTER AMENDMENT		(Column 2) HIGHEST NUMBER PREVIOUSLY PAID FOR		(Column 3) PRESENT EXTRA
<b>AMENDMENT A</b>	Total	* 53	Minus	** 20	=	33
	Independent	* 12	Minus	*** 6	=	6
FIRST PRESENTATION OF MULTIPLE DEPENDENT CLAIM						

SMALL ENTITY		OR	OTHER THAN SMALL ENTITY	
RATE	ADDITIONAL FEE		RATE	ADDITIONAL FEE
x\$11=	3123 pd	OR	x\$22=	
x38=	234 pd	OR	x76=	
+120=		OR	+240=	
TOTAL ADDIT. FEE		OR	TOTAL ADDIT. FEE	

		(Column 1) CLAIMS REMAINING AFTER AMENDMENT		(Column 2) HIGHEST NUMBER PREVIOUSLY PAID FOR		(Column 3) PRESENT EXTRA
<b>AMENDMENT B</b>	Total	* 68	Minus	** 53	=	15
	Independent	* 19	Minus	*** 12	=	7
FIRST PRESENTATION OF MULTIPLE DEPENDENT CLAIM						

SMALL ENTITY		OR	OTHER THAN SMALL ENTITY	
RATE	ADDITIONAL FEE		RATE	ADDITIONAL FEE
x\$11=	165.	OR	x\$22=	
x38=	21 287.	OR	x76=	
+120=		OR	+240=	
TOTAL ADDIT. FEE		OR	TOTAL ADDIT. FEE	

		(Column 1) CLAIMS REMAINING AFTER AMENDMENT		(Column 2) HIGHEST NUMBER PREVIOUSLY PAID FOR		(Column 3) PRESENT EXTRA
<b>AMENDMENT C</b>	Total	* 58	Minus	** 68	=	-
	Independent	* 16	Minus	*** 19	=	-
FIRST PRESENTATION OF MULTIPLE DEPENDENT CLAIM						

SMALL ENTITY		OR	OTHER THAN SMALL ENTITY	
RATE	ADDITIONAL FEE		RATE	ADDITIONAL FEE
x\$11=		OR	x\$22=	
x38=		OR	x76=	
+120=		OR	+240=	
TOTAL ADDIT. FEE		OR	TOTAL ADDIT. FEE	

\* If the entry in column 1 is less than the entry in column 2, write "0" in column 3.  
 \*\* If the "Highest Number Previously Paid For" IN THIS SPACE is less than 20, enter "20."  
 \*\*\* If the "Highest Number Previously Paid For" IN THIS SPACE is less than 3, enter "3."  
 The Highest Number Previously Paid For" (Total or Independent) is the highest number found in the appropriate box in column 1.

533115  
 709 227  
 Class Subclass  
 ISSUE CLASSIFICATION

73665

6108704

UTILITY SERIAL NUMBER 08 533115 PATENT DATE AUG 22 2000 PATENT NUMBER 6108704

CLASS 709 SUBCLASS 221 GROUP ART UNIT 2556 EXAMINER FTTG

APPLICANT'S NAME: *Novel RPA*  
*Porech*  
 ADDRESS: *2*  
*Kudirkad Jobse, LLP*  
*Two Center Plaza*  
*Boston, MA 02108*  
 U.S. DEPT. OF COMM. / PAT. & TRADEMARK OFFICE

Foreign priority claimed  yes  no  
 \*5 USC 119 conditions met  yes  no  
 AS FILED STATE OR COUNTRY SHEETS DRWGS. TOTAL CLAIMS INDEP. CLAIMS FILING FEE RECEIVED ATTORNEY-DOCKET NO.  
 Verified and Acknowledged Examiner's Initials

U.S. DEPT. OF COMM. / PAT. & TRADEMARK OFFICE

PARTS OF APPLICATION FILED SEPARATELY

NOTICE OF ALLOWANCE MAILED 5-25-99 Assistant Examiner CLAIMS ALLOWED Total Claims 44 Print Claim 1

ISSUE FEE Amount Due 3605.00 Date Paid 8/3/99 Mark H. Rinehart Primary Examiner SHEETS DRWG. 6 FIGS. DRWG. 9 PRINT FIG. 9

Label Area PREPARED FOR ISSUE ISSUE BATCH NUMBER T-56

WARNING: The information disclosed herein may be restricted. Unauthorized disclosure may be prohibited by the United States Code Title 35, Sections 122, 181 and 368. Possession outside the U.S. Patent & Trademark Office is restricted to authorized employees and contractors only.



35 Rule 312 Amst. 3-8-00  
 36.6-28-00 7-14-00  
 Formal Drawings (6 sheets) set

SEARCHED			
Class	Sub.	Date	Exmr.
395	200.01 200.02 200.09 200.11 200.15	5/24/99	PK
395	200.34 200.35 200.47 200.48 200.57 200.58 200.75	10/22/98     10/22/98	MR     R
709	204 205 217 218 227 228 235	5/12/99      5/12/99	UR      UR

SEARCH NOTES		
	Date	Exmr.
Discussion w/ Richard re: VLL & Internet References - w/in AFS - get w3 docs	5/22/99	PK
See AFS Search on Internet	5/16/99	PK
AFS search attached	10/26/98	MR

INTERFERENCE SEARCHED			
Class	Sub.	Date	Exmr.
709	227	5/12/99	UR
709	204	5/12/99	MR



08 53915  
 709 227  
 Class. Subclass. 12

Staple Issue Slip Here

UTILITY SERIAL NUMBER 08  
 SERIAL NUMBER 18E

POSITION	ID NO.	DATE
CLASSIFIER	5	10-17-95
EXAMINER	300	10-17-95
TYPIST	700	10/17
VERIFIER	74	10-17
CORPS CORR.		
SPEC. HAND		
FILE MAINT.		
DRAFTING		

APPLICANT'S VERIFICATION  
 Noz

INDEX OF CLAIMS

FOREIGN VERIFICATION  
 Pong

FOREIGN

Foreign priority claim  
 35 USC 119 condition

Verified and Acknowledged

ADDRESS

PARTS OF APPL. FILED SEPARATE NOTICE OF ALL

5-0  
 ISSU

Amount Due  
 \$605.00

La Ar

Form PTO-436A (Rev. 8/92)

Claim	Date				
	Final	Original	10/17/95	10/17/95	10/17/95
1					
2					
3					
4					
5					
6					
7					
8					
9					
10					
11					
12					
13					
14					
15					
16					
17					
18					
19					
20					
21					
22					
23					
24					
25					
26					
27					
28					
29					
30					
31					
32					
33					
34					
35					
36					
37					
38					
39					
40					
41					
42					
43					
44					
45					
46					
47					
48					
49					
50					

Claim	Date				
	Final	Original	10/17/95	10/17/95	10/17/95
51					
52					
53					
54					
55					
56					
57					
58					
59					
60					
61					
62					
63					
64					
65					
66					
67					
68					
69					
70					
71					
72					
73					
74					
75					
76					
77					
78					
79					
80					
81					
82					
83					
84					
85					
86					
87					
88					
89					
90					
91					
92					
93					
94					
95					
96					
97					
98					
99					
100					

SYMBOLS  
 ✓ ..... Rejected  
 = ..... Allowed  
 (Through numbers) Canceled  
 + ..... Restricted  
 N ..... Non-affected  
 A ..... Interference  
 O ..... Objected



2317

Cep 2301  
K. Sutton  
# 235  
12/14/95

RECEIVED  
NOV 21 1995  
GROUP 2300  
PATENT  
649-2

Atty. Docket No. 649-2

IN THE UNITED STATES PATENT AND TRADEMARK OFFICE

Applicant: Glenn W. Hutton                      Examiner:  
Serial No.: 08/533,115                              Group: Art Unit  
Filed: September 25, 1995                        Dated: October 25, 1995  
For: POINT-TO-POINT INTERNET  
      PROTOCOL

Commissioner of Patents  
and Trademarks  
Washington, D.C. 20231

RECEIVED

NOV 21 1995

GROUP 2300

INFORMATION DISCLOSURE STATEMENT

SIR:

It is respectfully requested that the disclosures discussed below (copies enclosed) and cited in annexed Form PTO-1449 be considered by the Examiner in connection with the above-identified patent application, and that such art be made of record in said application.

No representation is made or intended that a search of the art has been made or that no more relevant disclosures than those listed herein are available.

The items are identified as follows:

<u>U.S. Patent No.</u>	<u>Inventor</u>	<u>Issued</u>
5,150,360	Perlman et al.	Sept. 22, 1992

CERTIFICATE OF MAILING 37 C.F.R. § 1.8(a)

I hereby certify that this correspondence is being deposited with the United States Postal Service as first class mail, postpaid in an envelope, addressed to the: Commissioner of Patents and Trademarks, Washington, D.C. 20231.

Date: October 25, 1995

Anthony Natali  
(Name of person mailing paper)

[Signature]  
(Signature of person mailing paper)

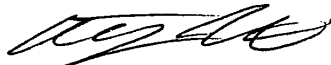
<u>U.S. Patent No.</u>	<u>Inventor</u>	<u>Issued</u>
5,204,669	Dorfe et al.	Apr. 20, 1993
5,224,095	Woest et al.	Jun. 29, 1993
5,291,554	Morales	Mar. 1, 1994
5,309,433	Cidon et al.	May 3, 1994
5,321,813	McMillen et al.	Jun. 14, 1994
5,357,571	Banwart	Oct. 18, 1994
5,400,335	Yamada	Mar. 21, 1995

The filing of this information disclosure statement is not an admission that the information cited herein is, or is considered to be, material to patentability as defined in 37 C.F.R. § 1.56(b).

- This Information disclosure statement is being filed concurrently with this application.
- This information disclosure statement is being filed within three (3) months of the filing date of this application.
- This information disclosure statement is being filed within three (3) months of the date of entry of the national stage as set forth in 37 C.F.R. § 1.491 in an international application.
- To the best of Applicant(s) knowledge, this information disclosure statement is being filed before the date of mailing of a first Office Action in connection with this case.
- Enclosed herewith is a certificate under 37 C.F.R. § 1.97(e).

- Enclosed herewith is a petition under 37 C.F.R. § 1.97(d)(ii).
- Enclosed by check is the petition fee of \$130.00. 37 C.F.R. § 1.17(i)(1))
- Please charge the \$130.00 petition fee to Deposit Account No. 04-1121.
- Enclosed by check is the \$200.00 fee required by 37 C.F.R. § 1.17(p).
- Please charge the \$200.00 fee required by 37 C.F.R. § 1.17(p) to Deposit Account No. 04-1121.
- Please charge any deficiency as well as any other fee(s) which may become due under 37 C.F.R. § 1.16 and/or 1.17 at any time during the pendency of this application, or credit any overpayment of such fee(s) to Deposit Account 04-1121. Also, in the event any extensions of time for responding are required for the pending application(s), please treat this paper as a petition to extend the time as required and charge Deposit Account No. 04-1121 therefor. **TWO (2) COPIES OF THIS SHEET ARE ENCLOSED.**

Respectfully submitted,



Anthony J. Natoli  
Reg. No. 36,223  
Attorney for Applicant(s)

DILWORTH & BARRESE  
333 Earle Ovington Blvd.  
Uniondale, NY 11553  
(516) 228-8484  
AJN/rmb

026-103  
08-102

2317  
H-86-94  
# 3/A



ATTORNEY DOCKET NO.: 649-2

THE UNITED STATES PATENT AND TRADEMARK OFFICE

Applicant: Glenn W. Hutton  
Serial No.: 08/533,115  
Filed: September 25, 1995  
For: POINT-TO-POINT INTERNET PROTOCOL  
Examiner: --  
Group:  
Art Unit:

RECEIVED  
APR 24 1996  
GROUP 2300

CERTIFICATE OF MAILING

I hereby certify that the following Amendment is being deposited with the United States Postal Service as first class mail in an envelope addressed to Assistant Commissioner of Patents, Washington, D.C. 20231 on April 5, 1996.

*Lorraine McConnell*  
Lorraine McConnell

Assistant Commissioner for Patents  
Washington, D.C. 20231

PRELIMINARY AMENDMENT

In the Specification

Page 6, line 11, change "Internet Telephone Company" to NetSpeak

Corporation, Boca Raton, FL,;

Page 6, line 17, change "are" to --may be--;

Page 7, line 2, after "Inc.," insert --Mountain View, CA,--;

Page 7, line 20, change "are" to --may be--.

Page 9, line 6, change "4-5" to --5-6--;

Page 9, line 12, after "corporation" insert --Redmond, WA,--;

Page 9, line 15, after "CORPORATION," insert --Boca Raton, FL,--

310 10 04717/96 08533115  
1 103 726.00 CK  
1 102 468.00 CK

1  
31

Page 19, line 14, change "point to-point" to --point-to-point--;

In the Claims

Please add the following claims.

*Sub C1* 21. A computer program product for use with a computer system, the computer system having first and second processors and a server operatively coupled over a computer network, the computer program product comprising:

a computer usable medium having program code means embodied in the medium for establishing a point-to-point communications link between the first processor and the second processor over the computer network, the medium further comprising:

program code means for transmitting, from the first processor to the server, a query as to whether the second processor is connected to the computer network;

program code means for receiving a network protocol address of the second processor from the server, when the second processor is connected to the computer network; and

program code means, responsive to the network protocol address of the second processor, for establishing a point-to-point communication link between the first processor and the second processor over the computer network.

*Sub B1* 22. A computer program product for use with a computer system, the computer system having first and second processors and a server operatively coupled over a computer network, the computer program product comprising:

a computer useable medium having program code means embodied in the medium for establishing a point-to-point communications link between the first processor and a second processor over a computer network, the medium further

A<sup>2</sup>

comprising:

program code means for transmitting an E-mail signal comprising a network protocol address from the first processor to the server over the computer network;

program code means for receiving a second network protocol address from the second processor over the computer network; and

program code means, responsive to the second network protocol address, for establishing a point-to-point communication link between the first processor and the second processor over a computer network.

*AR*  
*sub 27* 23. A computer server apparatus for enabling point-to-point communications between a first and a second processor over a computer network, the server apparatus comprising:

a server processor;

a network interface means, operatively coupled to the server processor, for connecting the server apparatus to the computer network;

a memory, operatively coupled to the processor, for storing a network protocol address for a plurality of processors connected to the computer network;

means, responsive to a query from the first processor, for determining the on-line status of the second processor and for transmitting the a network protocol address of the second processor to the first processor in response to a positive determination of the on-line status of the second processor.

24. The computer server apparatus of claim 23 further comprising a timer means, operatively coupled to the server processor, for time stamping the network protocol addresses stored in the memory.

25. The computer server apparatus of claim 23 further comprising:

mail processing means, responsive to an E-mail signal from the first processor, for forwarding the E-mail signal to the second processor, the E-mail signal comprising the network protocol address of the first processor.

26. In a connection server having a database and a computer network operatively coupled thereto, a method for enabling point-to-point communication between a first processing unit and a second processing unit over a computer network, the method comprising the steps of:

- A. storing in the database, a respective network protocol address for each of a plurality of processing units that have an on-line status with respect to the computer network;
- B. receiving a query from the first processing unit to determine the on-line status of the second processing unit;
- C. determining the on-line status of the second processing unit; and
- D. transmitting an indication of the on-line status of the second processing unit to the first processing unit over the computer network.

27. The method of claim 26 wherein step C further comprises the steps of:

- c.1 searching the database for an entry relating the second processing unit; and
- c.2 retrieving the network protocol address of the second processing unit in response to a positive determination of the on-line status of the second processing unit.

28. The method of claim 26 wherein step D further comprises the steps of:

- d.1 transmitting the network protocol address of the second processing unit to the first processing unit when the second processing unit is determined in



step C to have a positive on-line status with respect to the computer network.

29. The method of claim 26 wherein step D further comprises the steps of:

d.1 generating an off-line message when the second processing unit is determined in step C to have a negative on-line status with respect to the computer network; and

d.2 transmitting the off-line message to the first processing unit.

30. The method of claim 26 further comprising the steps of:

E. receiving an E-mail signal comprising a first network protocol address from the first processing unit; and

F. transmitting the E-mail signal over the computer network to the second processing unit.

31. The method of claim 30 wherein the E-mail signal further comprises a session number and wherein step F further comprises the step of:

f.1 transmitting the session number and network protocol address over the computer network to the second processor.

32. A method for establishing a point-to-point communication link from a caller processor to a callee processor over a computer network, the caller processor having a user interface and being operatively coupled to the callee processor and a server over the computer network, the method comprising the steps of:

A. generating an element representing a first communication line;

B. generating an element representing a first callee processor;

C. establishing a point-to-point communication link from the caller processor

to the first callee processor, in response to a user associating the element representing the first callee processor with the element representing the first communication line.

33. The method of claim 32 wherein step C further comprises the steps of:

c.1 querying the server as to the on-line status of the first callee processor;  
and

c.2 receiving a network protocol address of the first callee processor over the computer network from the server.

34. The method of claim 32 further comprising the step of:

D. generating an element representing a second communication line.

35. The method of claim 34 further comprising the step of:

E. terminating the point-to-point communication link from the caller processor to the first callee processor, in response to the user disassociating the element representing the first callee processor from the element representing the first communication line; and

F. establishing a different point-to-point communication link from the caller processor to the first callee processor, in response to the user associating the element representing the first callee processor with the element representing the second communication line.

36. The method of claim 32 further comprising the steps of:

D. generating an element representing a second callee processor; and

E. establishing a conference point-to-point communication link between the caller processor and the first and second callee processors, in response

to the user associating the element representing the second callee processor with the element representing the first communication line.

37. The method of claim 32 further comprising the step of:
- F. removing the second callee processor from the conference point-to-point communication link in response to the user disassociating the element representing the second callee processor from the element representing the first communication line.

38. The method of claim 32 further comprising the steps of:
- D. generating an element representing a communication line having a temporarily disabled status; and
  - E. temporarily disabling a point-to-point communication link between the caller processor and the first callee processor, in response to the user associating the element representing the first callee processor with the element representing the communication line having a temporarily disabled status.

39. The method of claim 38 wherein the element generated in step D represents a communication line on hold status.

40. The method of claim 39 wherein the element generated in step D represents a communication line on mute status.

41. The method of claim 32 wherein the caller processor further comprises a visual display and the user interface comprises a graphic user interface.

*Sub B2*

42. The method of claim 41 wherein the elements generated in steps A and B are graphic elements and the step of establishing a point-to-communication link as described in step C is performed in response to a user manipulating the graphic elements on the graphic user interface.

*sub C5*

43. A computer program product comprising:  
a computer usable medium having program code means embodied in the medium for establishing a point-to-point communication link from a caller processor to a callee processor over a computer network, the caller processor having a user interface and being operatively coupled to the callee processor and a server over the computer network, the medium further comprising:

*PR*

program code means for generating an element representing a first communication line;

program code means for generating an element representing a first callee processor;

program code means responsive to a user associating the element representing the first callee processor with the element representing the first communication line, for establishing a point-to-point communication link from the caller processor to the first callee processor.

44. The computer program product of claim 43 wherein the means for establishing a point-to-point communication link further comprises:

program code means for querying the server as to the on-line status of the first callee processor; and

program code means for receiving a network protocol address of the first callee processor over the computer network from the server.

45. A computer program product of claim 43 further comprising:  
program code means for generating an element representing a second communication line.

46. The computer program product of claim 45 further comprising:  
program code means, responsive to the user disassociating the element representing the first callee processor from the element representing the first communication line, for terminating the point-to-point communication link from the caller processor to the first callee processor; and

program code means, responsive to the user associating the element representing the first callee processor with the element presenting the second communication line, for establishing a different point-to-point communication link from the caller processor to the first callee processor.

47. The computer program product of claim 43 further comprising:  
program code means for generating an element representing a second callee processor; and

program code means, responsive to the user associating the element representing the second callee processor with the element representing the first communication line, for establishing a conference communication link between the caller processor and the first and second callee processors.

48. The computer program product of claim 47 further comprising:  
program code means, responsive to the user disassociating the element representing the second callee processor from the element representing the first communication line, for removing the second callee processor from the conference communication link.

49. The computer program product of claim 43 further comprising:  
program code means for generating an element representing a communication line having a temporarily disabled status; and

program code means, responsive to user associating the element representing the first callee processor with the element representing the communication line having a temporarily disabled status, for temporarily disabling the point-to-point communication link between the caller processor and the first callee processor.

50. The computer program product of claim 49 wherein the communication line having a temporarily disabled status comprises a communication line on hold status.

51. The computer program product of claim 49 wherein the communication line having a temporarily disabled status comprises a communication line on mute status.

52. A computer program product of claim 43 wherein the caller processor further comprises a visual display and the user interface comprises a graphic user interface.

53. The computer program product of claim 52 wherein the element representing the first communication line and the element representing the first callee processor are graphic elements and wherein the program code means for establishing a point-to-point communication link from the caller processor to the first callee processor further comprises:

program code means, responsive to a user manipulating the graphic elements on the graphic user interface, for establishing the point-to-point communication link from

AR

A2

~~the caller processor to the first callee processor.~~

REMARKS

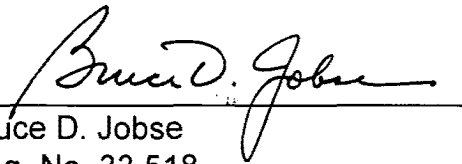
Prior to examining the above-identified application on the merits, Applicant respectfully requests the Examiner to enter the enclosed Preliminary Amendment. Applicant has made minor changes to the specification for greater clarity. No new matter is believed added to the application by the above amendments. In addition, Applicant has added claims 21-53 to more particularly point out and distinctly claim Applicant's inventive contributions to the relevant arts. Support for these claims exists in the specification as filed.

Claims 21-22 and 43-53 conform with In re Beauregard, 35 U.S.P.Q. 2d, 1383 (Fed. Cir. 1995) and the new Patent and Trademark Office policy.

The claims are believed allowable over any of the references cited by the Applicant, whether considered singularly or in combination. Accordingly, Applicant believes this application is in condition for allowance and a notice to that effect is respectfully requested. If the Examiner has any questions regarding this amendment or the application in general he is invited to call the Applicant's attorney at the number listed below.

The Commissioner is hereby authorized to charge any other fees under 37 C.F.R. §1.16 and 1.17 that may be required, or credit any overpayment, to our Deposit Account No. 20-0065.

Respectfully submitted,



Bruce D. Jobse  
Reg. No. 33,518  
Bookstein & Kudirka, P.C.  
One Beacon Street



ATTORNEY DOCKET NO.: 649-2

IN THE UNITED STATES PATENT AND TRADEMARK OFFICE

Applicant: Glenn W. Hutton  
Serial No.: 08/533,115  
Filed: September 25, 1995  
For: POINT-TO-POINT INTERNET PROTOCOL  
Examiner: --  
Group:  
Art Unit:

**RECEIVED**  
**APR 24 1996**  
**GROUP 2300**

Assistant Commissioner for Patents  
Washington, D.C. 20231

**AMENDMENT TRANSMITTAL LETTER**

Sir:

Transmitted herewith for filing in the above identified patent application are the following papers:

Preliminary Amendment

The fee is calculated as follows:

---

	Previously Paid				
Total Claims	53 - 20	= 33	X	\$22.00	= 726.00
Independent Claims	12 - 6	= 6	X	\$78.00	= <u>468.00</u>
			TOTAL		\$1,194.00

---

The Commissioner is hereby authorized to charge any other fees under 37 C.F.R.





ATTORNEY DOCKET NO.: 649-2

IN THE UNITED STATES PATENT AND TRADEMARK OFFICE

Applicant: Glenn W. Hutton  
Serial No.: 08/533,115  
Filed: September 25, 1995  
For: POINT-TO-POINT INTERNET PROTOCOL  
Examiner: --  
Group:  
Art Unit:

RECEIVED  
APR 24 1996  
GROUP 2300

Assistant Commissioner for Patents  
Washington, D.C. 20231

AMENDMENT TRANSMITTAL LETTER

Sir:

Transmitted herewith for filing in the above identified patent application are the following papers:

[X] Preliminary Amendment

The fee is calculated as follows:

---

	Previously Paid			
Total Claims	53 - 20	= 33	X	\$22.00 = 726.00
Independent Claims	12 - 6	= 6	X	\$78.00 = <u>468.00</u>
			TOTAL	\$1,194.00

---

The Commissioner is hereby authorized to charge any other fees under 37 C.F.R.

§§1.16 and 1.17 that may be required, or credit any overpayment, to our Deposit Account No. 02-3038.

Respectfully submitted,

I hereby certify that this correspondence is being deposited with the United States Postal Service as first class mail in an envelope addressed to: The Commissioner of Patents and Trademarks, Washington, D.C. 20231, on 4-5-96

Lorraine McConnell  
Lorraine McConnell

Bruce D. Jobse  
Bruce D. Jobse, Esq.  
Reg. No. 35,518  
BOOKSTEIN & KUDIRKA, P.C.  
One Beacon Street  
Boston, MA 02108  
(617) 367-4600

April 5, 1996



#4  
RE  
8/9/96

ATTORNEY'S DOCKET NO.: N0003/7000

IN THE UNITED STATES PATENT AND TRADEMARK OFFICE

APPLICANT: Glenn W. Hutton  
SERIAL NO.: 08/533,115  
FILED: September 25, 1995  
FOR: POINT-TO-POINT PROTOCOL

RECEIVED  
AUG 08 1996  
GROUP 2300

EXAMINER:  
ART UNIT: 2305

CERTIFICATE OF MAILING

I hereby certify that this correspondence is being deposited with the United States Postal Service as first class mail in an envelope addressed to: Assistant Commissioner for Patents, Washington, DC 20231 on July 25, 1996.

Debra M. Doherty (Typed or printed name of person mailing correspondence)      [Signature] (Signature of person mailing correspondence)

Assistant Commissioner for Patents  
Washington, DC 20231

Sir:

Transmitted herewith for filing is/are the following document(s):

[XX] Information Disclosure Statement, PTO Form 1449, in duplicate and cited reference

If the enclosed papers are considered incomplete, the Mail Room and/or the Application Branch is respectfully requested to contact the undersigned collect at (617) 367-4600, Boston, Massachusetts.

A check in the amount of \$--- is enclosed to cover the filing fee. If the fee is insufficient, the balance may be charged to the account of the undersigned, Deposit Account No. 02-3038. A duplicate of this sheet is enclosed.

Respectfully submitted,

[Signature]  
Bruce D. Jobse

Reg. No.: 33,518  
BOOKSTEIN & KUDIRKA  
One Beacon Street  
Boston, Massachusetts 02108  
Tel.: (617) 367-4600

ATTORNEY DOCKET NO.: N0003/7000  
DATE: JULY 25, 1996



ATTORNEY'S DOCKET NO.: N0003/7000

IN THE UNITED STATES PATENT AND TRADEMARK OFFICE

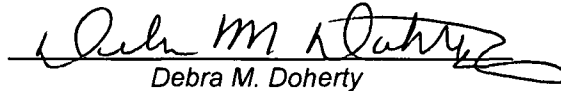
Applicant: Glenn W. Hutton  
Serial No.: 08/533,115  
Filed: September 25, 1995  
For: POINT-TO-POINT INTERNET PROTOCOL  
Examiner:  
Art Unit: 2305

RECEIVED  
AUG 08 1996  
GROUP 2300

---

CERTIFICATE OF MAILING UNDER 37 C.F.R. §1.8(a)

*The undersigned hereby certifies that this document is being placed in the United States mail with first-class postage attached, addressed to Assistant Commissioner for Patents, Washington, DC 20231 on the 25th day of July, 1996.*

  
Debra M. Doherty

---

Assistant Commissioner for Patents  
Washington, DC 20231

**STATEMENT FILED PURSUANT TO THE DUTY OF  
DISCLOSURE UNDER 37 C.F.R. §§1.56, 1.97 AND 1.98**

Sir:

Pursuant to the duty of disclosure under 37 C.F.R. §§1.56, 1.97 and 1.98, the applicant requests consideration of this information disclosure statement.

**Compliance with 37 C.F.R. §1.97**

This information disclosure statement has been filed before the mailing date of a first office action on the merits in the above-identified application. No fee or certification is required.

**Information Cited**

The applicant hereby makes of record in the above-identified application the information listed on the attached form PTO-1449 (modified). The order of presentation of the references should not be construed as an indication of the relative importance of the references.

**Remarks**

A copy of each of the above-identified information is enclosed unless otherwise indicated on the attached form PTO-1449 (modified). It is respectfully requested that:

- The examiner consider completely the cited information, along with any other information, in reaching a determination concerning the patentability of the present claims;
- The enclosed form PTO-1449 be signed by the examiner to evidence that the cited information has been fully considered by the Patent and Trademark Office during the examination of this application;
- The citations for the information be printed on any patent which issues from this application.

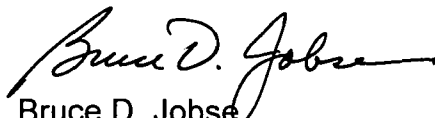
By submitting this information disclosure statement, the applicant makes no representation that a search has been performed, of the extent of any search performed, or that more relevant information does not exist.

By submitting this information disclosure statement, the applicant makes no representation that the information cited in the statement is, or is considered to be, material to patentability as defined in 37 C.F.R. §1.56(b).

By submitting this information disclosure statement, the applicant makes no representation that the information cited in the statement is, or is considered to be, in fact, prior art as defined by 35 U.S.C. §102.

It is understood by applicant that the foregoing information will be considered and, to the extent deemed appropriate by the examiner, will be reflected in the examiner's communication.

Respectfully submitted,



Bruce D. Jobse  
Reg. No. 33,518  
BOOKSTEIN & KUDIRKA, P.C.  
One Beacon Street  
Boston, Massachusetts 02108  
Tel: (617) 367-4600  
Attorneys for Applicant

Docket No.: N0003/7000

Date: July 25, 1996

*h:\bdj\7000\7000\ids.wpd*

#5



ATTORNEY'S DOCKET NO.: N0003/7000

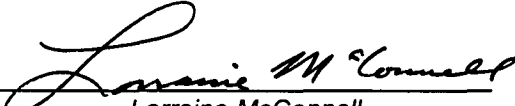
IN THE UNITED STATES PATENT AND TRADEMARK OFFICE

Applicant: Glenn W. Hutton  
Serial No.: 08/533,115  
Filed: September 25, 1995  
For: POINT-TO-POINT INTERNET PROTOCOL  
Examiner:  
Art Unit: 2305

RECEIVED  
AUG 21 1996  
GROUP 2300

CERTIFICATE OF MAILING UNDER 37 C.F.R. §1.8(a)

The undersigned hereby certifies that this document is being placed in the United States mail with first-class postage attached, addressed to Assistant Commissioner for Patents, Washington, DC 20231 on the 25th day of August 7, 1996.

  
Lorraine McConnell

Assistant Commissioner for Patents  
Washington, DC 20231

**STATEMENT FILED PURSUANT TO THE DUTY OF  
DISCLOSURE UNDER 37 C.F.R. §§1.56, 1.97 AND 1.98**

Sir:

Pursuant to the duty of disclosure under 37 C.F.R. §§1.56, 1.97 and 1.98, the applicant requests consideration of this information disclosure statement.

**Compliance with 37 C.F.R. §1.97**

This information disclosure statement has been filed before the mailing date of a first office action on the merits in the above-identified application. No fee or certification is required.

**Information Cited**

The applicant hereby makes of record in the above-identified application the information listed on the attached form PTO-1449 (modified). The order of presentation of the references should not be construed as an indication of the relative importance of the references.

**Remarks**

A copy of each of the above-identified information is enclosed unless otherwise indicated on the attached form PTO-1449 (modified). It is respectfully requested that:

- The examiner consider completely the cited information, along with any other information, in reaching a determination concerning the patentability of the present claims;
- The enclosed form PTO-1449 be signed by the examiner to evidence that the cited information has been fully considered by the Patent and Trademark Office during the examination of this application;
- The citations for the information be printed on any patent which issues from this application.

By submitting this information disclosure statement, the applicant makes no representation that a search has been performed, of the extent of any search performed, or that more relevant information does not exist.

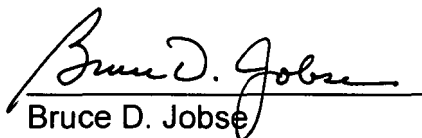
By submitting this information disclosure statement, the applicant makes no representation that the information cited in the statement is, or is considered to be, material to patentability as defined in 37 C.F.R. §1.56(b).

By submitting this information disclosure statement, the applicant makes no representation that the information cited in the statement is, or is considered to be, in fact, prior art as defined by 35 U.S.C. §102.



It is understood by applicant that the foregoing information will be considered and, to the extent deemed appropriate by the examiner, will be reflected in the examiner's communication.

Respectfully submitted,



Bruce D. Jobse  
Reg. No. 33,518  
BOOKSTEIN & KUDIRKA, P.C.  
One Beacon Street  
Boston, Massachusetts 02108  
Tel: (617) 367-4600  
Attorneys for Applicant

Docket No.: N0003/7000

Date: August 7, 1996

*h:\bdj\0003\7000\ids.wpd*



ATTORNEY'S DOCKET NO.: N0003/7000

IN THE UNITED STATES PATENT AND TRADEMARK OFFICE

APPLICANT: Glenn W. Hutton  
SERIAL NO.: 08/533,115  
FILED: September 25, 1995  
FOR: POINT-TO-POINT INTERNET PROTOCOL  
  
EXAMINER:  
ART UNIT: 2305

RECEIVED  
AUG 21 1996  
GROUP 2300

CERTIFICATE OF MAILING

I hereby certify that this correspondence is being deposited with the United States Postal Service as first class mail in an envelope addressed to: Assistant Commissioner for Patents, Washington, DC 20231 on August 7, 1996.

Lorraine McConnell  
(Typed or printed name of person mailing correspondence)

Lorraine M<sup>c</sup>Connell  
(Signature of person mailing correspondence)

Assistant Commissioner for Patents  
Washington, DC 20231

Sir:

Transmitted herewith for filing is/are the following document(s):

[XX] Information Disclosure Statement, PTO Form 1449, and cited reference

If the enclosed papers are considered incomplete, the Mail Room and/or the Application Branch is respectfully requested to contact the undersigned collect at (617) 367-4600, Boston, Massachusetts.

A check in the amount of \$--- is enclosed to cover the filing fee. If the fee is insufficient, the balance may be charged to the account of the undersigned, Deposit Account No. 02-3038. A duplicate of this sheet is enclosed.

Respectfully submitted,

Bruce D. Jobse

Bruce D. Jobse  
Reg. No.: 33,518  
BOOKSTEIN & KUDIRKA  
One Beacon Street  
Boston, Massachusetts 02108  
Tel.: (617) 367-4600

ATTORNEY DOCKET NO.: N0003/7000  
DATE: August 7, 1996



ATTORNEY'S DOCKET NO.: N0003/7000

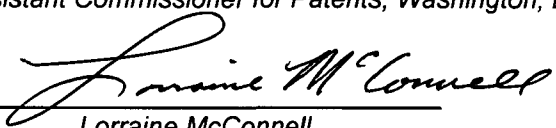
# 6  
J-eps  
9/17/96  
RECEIVED  
SEP 16 1996  
GROUP 2300

IN THE UNITED STATES PATENT AND TRADEMARK OFFICE

Applicant: Glenn W. Hutton  
Serial No.: 08/533,115  
Filed: September 25, 1995  
For: POINT-TO-POINT INTERNET PROTOCOL  
Examiner:  
Art Unit: 2305

CERTIFICATE OF MAILING UNDER 37 C.F.R. §1.8(a)

The undersigned hereby certifies that this document is being placed in the United States mail with first-class postage attached, addressed to Assistant Commissioner for Patents, Washington, DC 20231 on the 6th day of September, 1996.

  
Lorraine McConnell

Assistant Commissioner for Patents  
Washington, DC 20231

**STATEMENT FILED PURSUANT TO THE DUTY OF  
DISCLOSURE UNDER 37 C.F.R. §§1.56, 1.97 AND 1.98**

Sir:

Pursuant to the duty of disclosure under 37 C.F.R. §§1.56, 1.97 and 1.98, the applicant requests consideration of this information disclosure statement.

**Compliance with 37 C.F.R. §1.97**

This information disclosure statement has been filed before the mailing date of a first office action on the merits in the above-identified application. No fee or certification is required.

**Information Cited**

The applicant hereby makes of record in the above-identified application the information listed on the attached form PTO-1449 (modified). The order of presentation of the references should not be construed as an indication of the relative importance of the references.

**Remarks**

A copy of each of the above-identified information is enclosed unless otherwise indicated on the attached form PTO-1449 (modified). It is respectfully requested that:

- The examiner consider completely the cited information, along with any other information, in reaching a determination concerning the patentability of the present claims;
- The enclosed form PTO-1449 be signed by the examiner to evidence that the cited information has been fully considered by the Patent and Trademark Office during the examination of this application;
- The citations for the information be printed on any patent which issues from this application.

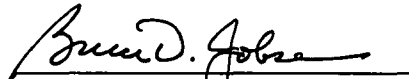
By submitting this information disclosure statement, the applicant makes no representation that a search has been performed, of the extent of any search performed, or that more relevant information does not exist.

By submitting this information disclosure statement, the applicant makes no representation that the information cited in the statement is, or is considered to be, material to patentability as defined in 37 C.F.R. §1.56(b).

By submitting this information disclosure statement, the applicant makes no representation that the information cited in the statement is, or is considered to be, in fact, prior art as defined by 35 U.S.C. §102.

It is understood by applicant that the foregoing information will be considered and, to the extent deemed appropriate by the examiner, will be reflected in the examiner's communication.

Respectfully submitted,



Bruce D. Jobse  
Reg. No. 33,518  
BOOKSTEIN & KUDIRKA, P.C.  
One Beacon Street  
Boston, Massachusetts 02108  
Tel: (617) 367-4600  
Attorneys for Applicant

Docket No.: N0003/7000

Date: September 6, 1996

*h:\bdj\0003\7000\ids.wpd*

#6



IN THE UNITED STATES PATENT AND TRADEMARK OFFICE

RECEIVED  
SEP 16 1996  
GROUP 2300

APPLICANT: Glenn W. Hutton  
SERIAL NO.: 08/533,115  
FILED: September 25, 1995  
FOR: POINT-TO-POINT INTERNET PROTOCOL

EXAMINER: --  
ART UNIT: 2305

CERTIFICATE OF MAILING

I hereby certify that this correspondence is being deposited with the United States Postal Service as first class mail in an envelope addressed to: Assistant Commissioner for Patents, Washington, DC 20231 on September 6, 1996.

Lorraine McConnell  
(Typed or printed name of person mailing correspondence)

Lorraine M. McConnell  
(Signature of person mailing correspondence)

Assistant Commissioner for Patents  
Washington, DC 20231

Sir:

Transmitted herewith for filing is/are the following document(s):

[XX] Information Disclosure Statement, PTO Form 1449, and references cited

If the enclosed papers are considered incomplete, the Mail Room and/or the Application Branch is respectfully requested to contact the undersigned collect at (617) 367-4600, Boston, Massachusetts.

A check in the amount of \$-0- is enclosed to cover the filing fee. If the fee is insufficient, the balance may be charged to the account of the undersigned, Deposit Account No. 02-3038. A duplicate of this sheet is enclosed.

Respectfully submitted,

Bruce D. Jobse

Bruce D. Jobse  
Reg. No.: 33,518  
BOOKSTEIN & KUDIRKA  
One Beacon Street  
Boston, Massachusetts 02108  
Tel.: (617) 367-4600

ATTORNEY DOCKET NO.: N0003/7000  
DATE: September 6, 1996



THE UNITED STATES PATENT AND TRADEMARK OFFICE

In re application of: Glenn W. Hutton

Serial No. 08/533,115

Filed: September 25, 1995

For: POINT-TO-POINT INTERNET PROTOCOL

Examiner:

Art Unit: 2305

BOOKSTEIN & KUDIRKA, P.C.  
One Beacon Street  
Boston, MA 02108

96 SEP 27 PM 12:04

CERTIFICATE OF MAILING

I hereby certify that the following document is being deposited with the United States Postal Service as first class mail in an envelope addressed to: Assistant Commissioner for Patents and Trademarks, Washington, D.C. 20231 on 5/28/96.

Bruce D. Jobse

REVOCATION AND NEW POWER OF ATTORNEY

Netspeak, Corporation, assignee of United States Patent Application Serial No. 08/533,115, filed 9/25/95, hereby revokes all powers of attorney previously given and hereby appoints Arthur Bookstein, Reg. No. 22,958, Paul E. Kudirka, Reg. No. 26,931, Paul J. Cook, Reg. No. 20,820, Bruce D. Jobse, Reg. No. 33,518, Philip L. Conrad, Reg. No. 34,567, Peter M. Dichiara, Reg. No. 38,005, John F. Perullo, Reg. No. 39,498, Christopher S. Daly, Reg. No. 37,303, Steven G. Saunders, Reg. No. 36,265, and BOOKSTEIN & KUDIRKA, P.C. One Beacon Street, Boston, Massachusetts 02108 jointly, and each of them severally, its attorneys at law, with full power of substitution, delegation and revocation, to prosecute this application to register, to make alterations and amendments therein, to receive the patent, and to transact all business in the Patent and Trademark Office connected therewith. Please direct all telephone calls to Bruce D. Jobse at (617) 367-4600, please address all correspondence to Bruce D. Jobse.

Date: May 9, 1996

By:   
Harvey Kaufman  
Vice President and Secretary,  
NetSpeak, Corp



THE UNITED STATES PATENT AND TRADEMARK OFFICE

In re application of: Glenn W. Hutton

Serial No. 08/533,115

Filed: September 25, 1995

For: POINT-TO-POINT INTERNET PROTOCOL

Examiner:

Art Unit:

Assistant Commissioner for Patents  
Washington, DC 20231

96 SEP 27 PM 12:04

LETTER

Dear Sir:

The enclosed Revocation and New Power of Attorney was submitted to the United States Patent and Trademark Office on May 28, 1996 along with two patent assignments and accompanying covers sheets. A copy of the transmittal letter and stamped return postcard which accompanied these documents is enclosed. The Revocation and Power of Attorney form was subsequently returned, possibly erroneously, with a Notice of Recordation of one the assignments dated September 3, 1996. Applicant is herewith submitting the Revocation of Power of Attorney form again so that it may be made of record in the above-identified application.

If the Examiner has any questions regarding this communication or the application in general, he is invited to call Applicant's attorney at the number listed below.

Respectfully submitted,

Bruce D. Jobse, Esq.  
Reg. No. 33,518  
Bookstein & Kudirka, P.C.  
One Beacon Street  
Boston, MA 02108  
(617) 367-4600

Attorney Docket No.: N0003/7000

Date: September 17, 1996





ATTORNEY'S DOCKET NO.: N0003/7000

IN THE UNITED STATES PATENT AND TRADEMARK OFFICE

APPLICANT: Glenn W. Hutton  
SERIAL NO.: J8/533,115  
FILED: September 25, 1995  
FOR: POINT-TO-POINT INTERNET PROTOCOL  
EXAMINER: --  
ART UNIT: --

**COPY**

Assistant Commissioner for Patents  
Box Assignment  
Washington, DC 20231

Sir:

Transmitted herewith for filing is/are the following document(s):

- [XX] Two Patent Assignments With Cover Sheets
- [XX] Revocation and New Power of Attorney

If the enclosed papers are considered incomplete, the Mail Room and/or the Application Branch is respectfully requested to contact the undersigned collect at (617) 367-4600, Boston, Massachusetts.

A \$40.00 check is enclosed for each Assignment to cover the filing fee. If the fee is insufficient, the balance may be charged to the account of the undersigned, Deposit Account No. 02-3038. A duplicate of this sheet is enclosed.

Respectfully submitted,

I hereby certify that this correspondence is being deposited with the United States Postal Service as first class mail in an envelope addressed to: The Commissioner of Patents and Trademarks, Washington, D.C. 20231, on 5/28/96

Bruce D. Jobse  
\_\_\_\_\_  
\_\_\_\_\_

Bruce D. Jobse  
Bruce D. Jobse, Esq.  
Reg. No.: 33,518  
BOOKSTEIN & KUDIRKA, P.C.  
One Beacon Street  
Boston, Massachusetts 02108  
Tel.: (617) 367-4600

ATTORNEY DOCKET NO.: N0003/7000  
DATE: May 28, 1996  
XNDD

96 SEP 27 PM 12:04

JUN 06 1996  
*dm*

DOCKETED

JUN 6 1996

**COPY**

Serial No. 08/533,115 File No. NU00077000 By: BOS/KM  
Title: Point-to-Point Internet Protocol  
Application of: Oliver W. Hutton

• The following, DUE 11/1 in the U.S. PTO, was received in the PTO Mail Room on the date stamped hereon.

- |  |  |
|--|--|
| <input type="checkbox"/> Cert. of Mailing by Express Mail (37 CFR 1.10)<br>Express Mail Label No. _____  | <input type="checkbox"/> Inf. Discl. Statement, PTO Form 1449 and<br>References Cited        |
| <input checked="" type="checkbox"/> Cert. of Mailing under 37 CFR 1.8 (a)  | <input type="checkbox"/> PCT Request, 101 (____ sheets)                                      |
| <input type="checkbox"/> Application for Patent Incl. _____ pages,<br>(____ pgs) Specification, (____ pgs) Abstract,<br>(____ pgs) Claims (____ #claims) | <input type="checkbox"/> Chapter II Demand   |
| <input type="checkbox"/> Affidavit or <input type="checkbox"/> Declaration/Oath  | <input type="checkbox"/> PCT Fee/Calculation/Authorization Sheet                             |
| <input type="checkbox"/> Design Patent Application & Declaration/Oath  | <input type="checkbox"/> Certificate of Service  |
| <input type="checkbox"/> Drawings _____ Sheet(s) (Figs. _____)<br>[ ] Formal or [ ] Informal drawings  | <input checked="" type="checkbox"/> Check for \$ <u>80.00</u><br>Check # <u>PAID 30 1993</u> |
| <input type="checkbox"/> Multiple Dependent Claim Fee Sheet  | <input type="checkbox"/> Amendment   |
| <input type="checkbox"/> Priority Document(s) # _____  | <input type="checkbox"/> Letter to Official Draftsman  |
| <input type="checkbox"/> Verified Statement to establish small<br>entity status  | <input type="checkbox"/> Declaration w/ copy of notice to the Missing Parts                  |
| <input checked="" type="checkbox"/> Assignment + <u>Cover sheet x 2</u>  | <input type="checkbox"/> Notice of Appeal  |
| <input type="checkbox"/> Req. for Filing [ ] Cont. [ ] Div. Appln.<br>under 37 CFR 1.60  | <input type="checkbox"/> Power of Attorney   |
| <input type="checkbox"/> File Wrapper Contin (FWC) under 37 CFR 1.62   | <input type="checkbox"/> Motion/Opposition/Reply   |
| <input checked="" type="checkbox"/> Other <u>Revocation + New Power of Attorney</u>  | <input type="checkbox"/> Brief (____ x3)   |

MAILED 6/28/96



2302

CR235

ATTORNEY'S DOCKET NO.: N0003/7000

IN THE UNITED STATES PATENT AND TRADEMARK OFFICE

APPLICANT: Glenn W. Hutton  
SERIAL NO.: 08/533,115  
FILED: September 25, 1995  
FOR: POINT-TO-POINT INTERNET PROTOCOL  
EXAMINER: --  
ART UNIT: --

Assistant Commissioner for Patents  
Washington, DC 20231

96 SEP 27 PM 12: 04

Sir:

Transmitted herewith for filing is/are the following document(s):

- Letter
- Revocation and New Power of Attorney
- Copies of Previous Submission of Transmittal Letter and Stamped Post Card

If the enclosed papers are considered incomplete, the Mail Room and/or the Application Branch is respectfully requested to contact the undersigned collect at (617) 367-4600, Boston, Massachusetts.

If the fee is insufficient, the balance may be charged to the account of the undersigned, Deposit Account No. 02-3038. A duplicate of this sheet is enclosed.

Respectfully submitted,

I hereby certify that this correspondence is being deposited with the United States Postal Service as first class mail in an envelope addressed to: The Commissioner of Patents and Trademarks, Washington, D.C. 20231, on 9/17/96

Lorraine McConnell

Bruce D. Jobse  
Bruce D. Jobse Esq.  
Reg. No.: 33,518  
BOOKSTEIN & KUDIRKA, P.C.  
One Beacon Street  
Boston, Massachusetts 02108  
Tel.: (617) 367-4600

ATTORNEY DOCKET NO.: N0003/7000  
DATE: September 17, 1996  
XNDD



**UNITED STATES DEPARTMENT OF COMMERCE**  
**Patent and Trademark Office**  
 Address: COMMISSIONER OF PATENTS AND TRADEMARKS  
 Washington, D.C. 20231

APPLICATION NUMBER	FILING DATE	FIRST NAMED APPLICANT	ATTORNEY DOCKET NO.
08/533115	09/25/95	HUTTON	649-2

EXAMINER	
FAN, DANIEL	
ART UNIT	PAPER NUMBER

JOSEPH J CATANZARO  
 DILWORTH & BARRESE  
 333 EARLE OVINGTON BLVD  
 UNIONDALE NY 11553

DATE MAILED: 2302 8

10/02/96

10/02/96

This is a communication from  
 the Patent & Trademark Office

This is in response to the Power of Attorney filed SEPTEMBER 20, 1996

- 1. The Power of Attorney to you in this application has been revoked by the applicant. Future correspondence will be mailed to the new address of record. 37 CFR 1.33.
- 2. The Power of Attorney to you in this application has been revoked by the assignee who has intervened as provided by 37 CFR 3.71. Future correspondence will be mailed to the new address of record. (37 CFR 1.33)
- 3. The withdrawal as attorney in this application has been accepted. Future correspondence will be mailed to the new address of record. 37 CFR 1.33.
- 4. The Power of Attorney in this application is accepted. Correspondence in this application will be mailed to the below-noted address as provided by 37 CFR 1.33.
- 5. The Power of Attorney in this application is not accepted for the reason(s) checked below:
  - a. The Power of Attorney is from an assignee and the Certificate required by 37 CFR 3.73 (b) has not been received.
  - b. The person signing for the assignee has omitted their empowerment to sign on behalf of the assignee.
  - c. The inventor(s) is without authority to appoint attorneys since the assignee has intervened as provided by 37 CFR 3.71.
  - d. The signature of \_\_\_\_\_, a co-inventor in this application, has been omitted. The Power of Attorney will be entered upon receipt of confirmation signed by said co-inventor.
  - e. The person(s) appointed in the Power of Attorney is not registered to practice before the U.S. Patent & Trademark Office.
  - f. The revocation is not signed by the applicant, the assignee of the entire interest, or one particular principal attorney having the authority to revoke.

BOOSTEIN & KUDIRKA, PC  
 ONE BEACON STREET  
 BOSTON, MASSACHUSETTS 02102

*DALE A. HALL*  
 DALE A. HALL  
 GROUP 2300



#9  
SM  
11/14/96

PATENT  
ATTORNEY DOCKET NO. N0003/7000

**IN THE UNITED STATES PATENT AND TRADEMARK OFFICE**

In Re The Application of: Glenn W. Hutton  
Serial No. 08/533,115  
Filed: September 25, 1995  
For: POINT-TO-POINT INTERNET PROTOCOL  
Examiner: D. Pan  
Art Unit: 2302

RECEIVED  
NOV 6 1996  
GROUP 2300

BOOKSTEIN & KUDIRKA, P.C.  
One Beacon Street  
Boston, MA 02108  
(617) 367-4600

**STATUS LETTER**

Please inform us of the status for the above-identified patent application, and when you expect to examine such.

I hereby certify that this correspondence is being deposited with the United States Postal Service as first class mail in an envelope addressed to: Commissioner of Patents and Trademarks, Washington, D.C. 20231, on October 18, 1996

Rosemarie Mullin  
Rosemarie Mullin

Respectfully submitted,

Bruce D. Jobse, Esq.  
Reg. No. 33,518  
BOOKSTEIN & KUDIRKA, P.C.  
One Beacon Street  
Boston, MA 02108  
(617) 367-4600

Date: 10/18/96



ATTORNEY DOCKET NO. N0003/7000

IN THE UNITED STATES PATENT AND TRADEMARK OFFICE

Applicant: Glenn W. Hutton  
Serial No.: 08/533,115  
Filed: September 25, 1995  
For: POINT-TO-POINT INTERNET PROTOCOL  
Examiner: --  
Art Unit: 2302

RECEIVED  
MAY 13 97  
GROUP 2600

CERTIFICATE OF MAILING UNDER 37 C.F.R. §1.8(a)

The undersigned hereby certifies that this document is being placed in the United States mail with first-class postage attached, addressed to Assistant Commissioner for Patents, Washington, DC 20231 on the 17th day of April, 1997.

*Frances M. Cunningham*  
\_\_\_\_\_  
Frances M. Cunningham

Assistant Commissioner for Patents  
Washington, D.C. 20231

**PETITION TO ADD TO ORIGINALLY NAMED INVENTOR(S) UNDER 37 CFR 1.48(c)**

Sir:

Applicant respectfully requests that the above-identified application be amended under 37 CFR 1.48(c) to add inventors for subject matter disclosed in the application but previously unclaimed.

Please add the following inventors:

Shane D. Mattaway  
826 Periwinkle Street  
Boca Raton, FL 33486

Craig B. Strickland  
5713 NW 65th Terrace  
Tamarac, FL 33321

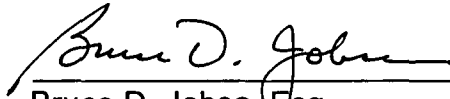
Attached with this petition are the following:

- A. Statement of facts verified by the original-named inventor establishing when the claims to the previously disclosed unclaimed subject matter by the inventors not named in the application were added and the diligence with which this petition and amendment is being made with respect to these facts;
- B. Declaration by each of the actual inventors as required under 37 CFR §1.63;
- C. Written assent of the assignee; and
- D. Payment of the fee required under 37 CFR §1.17(h) of \$130.00

A check in the amount of \$130.00 is enclosed to cover the filing fee. If the fee is insufficient, the balance may be charged to the account of the undersigned, Deposit Account No. 02-3038. A duplicate of this sheet is enclosed.

Respectfully submitted,

April 17, 1997

  
\_\_\_\_\_  
Bruce D. Jobse, Esq.  
Reg. No. 33,518  
BOOKSTEIN & KUDIRKA, P.C.  
One Beacon Street  
Boston, MA 02108  
(617) 367-4600

H:\BDJ\N0003\7000\PETCORR.WPD



Attorney Docket No. N0003/7000

THE UNITED STATES PATENT AND TRADEMARK OFFICE

APPLICANT Shane D. Mattaway et al.  
SERIAL NO.: 08/533,115  
FILED: September 25, 1995  
FOR: POINT-TO-POINT INTERNET PROTOCOL  
EXAMINER:  
ART UNIT: 2302

RECEIVED  
MAY 13 97  
GROUP 2600

CERTIFICATE OF MAILING

I hereby certify that this correspondence is being deposited with the United States Postal Service as first class mail in an envelope addressed to: Assistant Commissioner for Patents, Washington, DC 20231, on April 17, 1997.

Frances M. Cunningham

(Typed or printed name of person mailing correspondence)

Frances M. Cunningham

(Signature of person mailing correspondence)

Assistant Commissioner for Patents  
Washington, D.C. 20231

ASSENT OF ASSIGNEE

NetSpeak Corporation, the assignee of record for the above-identified U.S. Patent Application, by way of a first assignment dated November 27, 1995 from Glenn W. Hutton to the Internet Telephone Company, Reel 7981, Frame 0020, and a second assignment from the Internet Telephone Company to NetSpeak Corporation dated May 14, 1996, Reel 7981, Frame 0053, hereby consents to the addition of Shane D. Mattaway and Craig B. Strickland as inventors to the application.

4/15/97

Date

Stephen R. Cohen  
Stephen R. Cohen  
Chief Executive Officer  
NetSpeak Corporation

C:\WINDOWS\TEMP\ASSENTAS.WPD



IN THE UNITED STATES PATENT AND TRADEMARK OFFICE

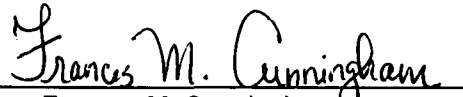
Applicant: Glenn W. Hutton  
Serial No.: 08/533,115  
Filed: September 25, 1995  
For: POINT-TO-POINT INTERNET PROTOCOL  
Examiner: --  
Art Unit: 2302

---

CERTIFICATE OF MAILING UNDER 37 C.F.R. §1.8(a)

The undersigned hereby certifies that this document is being placed in the United States mail with first-class postage attached, addressed to Assistant Commissioner for Patents, Washington, DC 20231 on

April 17, 1997

  
\_\_\_\_\_  
Frances M. Cunningham

---

Assistant Commissioner for Patents  
Washington, D.C. 20231

STATEMENT OF FACTS IN SUPPORT OF PETITION  
TO ADD INVENTORS UNDER 37 CFR §1.48(C)

Statement of Facts

1. On September 25, 1995, patent application serial number 08/533,155, entitled "Point-to-Point Internet Protocol" was filed on my behalf, as sole inventor, by Anthony J. Natoli, Esq., Reg. No. 36,223, of the law firm of Dilworth & Barrese, Uniondale, New York, NY.
2. On November 27, 1995 I assigned all right, title and interest in and to the patent application to the Internet Telephone Company, a Florida corporation having a place of business at One South Ocean Boulevard, Suite 305, Boca Raton, Florida 33432.
3. In March of 1996, NetSpeak Corporation, parent corporation of the Internet Telephone Company, retained the services of Bruce D. Jobse, Esq., Reg. No. 33,518, of the law firm of Bookstein & Kudirka, Boston, Massachusetts, to prosecute

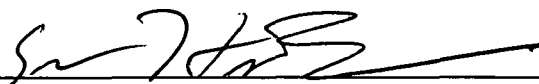
the above-identified application.

4. On April 5, 1996 a preliminary amendment to the patent application was filed adding claims 21-53, some of which were directed to subject matter previously disclosed but not yet claimed.

5. I became aware of the preliminary amendment and the additional claims during a telephone conversation with attorney Bruce D. Jobse sometime in late November 1996.

6. On December 11, 1996 I received a copy of the above-mentioned preliminary amendment filed April 5, 1996. I acknowledge that both Shane D. Mattaway and Craig B. Strickland contributed to the subject matter of at least one currently pending claim of the above-identified application. The necessity of naming Shane D. Mattaway and Craig B. Strickland as inventors was discovered sometime between my subsequent review of the copy of the preliminary amendment and the date of this Statement of Facts. A diligent effort has been made to correct this error.

I hereby declare that all statements made herein of my own knowledge are true and that statements made on information and belief are believed to be true and further that the statements were made with the knowledge that willful false statements and the like so made are punishable by fine or imprisonment, or both under Section 1001 of Title 18 of United States Code, and that such willful, false statements may jeopardize the validity of the application or any patents issued therefrom.

  
\_\_\_\_\_  
Glenn W. Hutton

4-2-97  
\_\_\_\_\_  
Date

~~4-2-97 5713 NW 65th Terrace, Tamarac, FL 33321~~  
SA 9725 HANNOCKS BLVD #206  
Citizen: Canada MIAMI, FL. 33196  
H:\BDJ\N0003\7000\STMTFACT.WPD

# DECLARATION AND POWER OF ATTORNEY FOR PATENT APPLICATION

As a below named inventor, I hereby declare that:

My residence, post office address and citizenship are stated below next to my name:

I believe I am an original, first and joint inventor the subject matter which is claimed and for which a patent is sought on the invention entitled **POINT-TO-POINT INTERNET PROTOCOL**, the specification of which was filed on September 25, 1995 under Attorney's Docket Number N0003/7000, now U.S. Patent Application Serial No. 08/533,115.

I hereby state that I have reviewed and understand the contents of the above identified patent application, including the claims as amended by any amendment referred to above.

I acknowledge the duty to disclose information which is material to the patentability of this application in accordance with 37 C.F.R. 1.56.

I hereby claim the benefit of foreign priority under 35 U.S.C. 119 of any foreign application(s) for patent or inventor's certificate having a filing date before that of the application the priority of which is claimed:

Prior Foreign Application(s):			Priority Claimed
_____	_____	_____	_____ Yes _____ No
(Number)	(Country)	(Filing Date)	

I hereby claim the benefit of United States priority under 35 U.S.C. 120 of any United States application(s) listed below and, insofar as the subject matter of each of the claims of this application is not disclosed in a listed prior United States application in the manner provided by the first paragraph of 35 U.S.C. 112, I acknowledge the duty to disclose information material to the patentability of this application as defined in 37 C.F.R. 1.56 which occurred between the filing date of the prior application and the national or PCT international filing date of this application.

_____	_____	_____
(Application Serial #)	(Filing Date)	(Status)
_____	_____	_____
(Application Serial #)	(Filing Date)	(Status)
_____	_____	_____
(Application Serial #)	(Filing Date)	(Status)

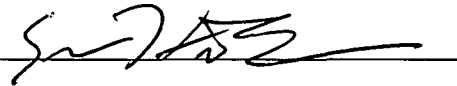
I hereby declare that all statements made herein of my own knowledge are true and that all statements made on information and belief are believed to be true; and further that these statements were made with the knowledge that willful false statements and the like so made are punishable by fine or imprisonment, or both, under 18 U.S.C. 1001 and that such willful false statements may jeopardize the validity of the application or any patent issued thereon.

POWER OF ATTORNEY: As a named inventor, I hereby appoint the following attorneys and/or agents to prosecute this application and transact all business in the Patent and Trademark Office connected therewith.

Bruce D. Jobse	Reg. No. 33,518	Paul E. Kudirka	Reg. No. 26,931
Arthur Z. Bookstein	Reg. No. 22,958	John F. Perullo	Reg. No. 36,265
Philip L. Conrad	Reg. No. 34,567	Steven G. Saunders	Reg. No. 36,265
Paul J. Cook	Reg. No. 20,280		

Send correspondence to Bruce D. Jobse, BOOKSTEIN & KUDIRKA, P.C., One Beacon Street, Boston, Massachusetts, 02108.

FULL NAME OF INVENTOR: Glenn W. Hutton

INVENTOR'S SIGNATURE:  DATE: 4-2-97

RESIDENCE: 9725 Hammocks Boulevard, #206, Miami, FL 33196  
CITIZENSHIP: Canada  
POST OFFICE ADDRESS: 9725 Hammocks Boulevard, #206, Miami, FL 33196

---

---

FULL NAME OF INVENTOR: Shane D. Mattaway

INVENTOR'S SIGNATURE: \_\_\_\_\_ DATE: \_\_\_\_\_

RESIDENCE: 826 Periwinkle, Boca Raton, FL 33486  
CITIZENSHIP: U.S.A.  
POST OFFICE ADDRESS: 826 Periwinkle, Boca Raton, FL 33486

---

---

FULL NAME OF INVENTOR: Craig B. Strickland

INVENTOR'S SIGNATURE: \_\_\_\_\_ DATE: \_\_\_\_\_

RESIDENCE: 5713 NW 65th Terrace, Tamarac, FL 33321  
CITIZENSHIP: Canada  
POST OFFICE ADDRESS: 5713 NW 65th Terrace, Tamarac, FL 33321

H:\BDJ\N0003\7000\DECL.WPD

## DECLARATION AND POWER OF ATTORNEY FOR PATENT APPLICATION

As a below named inventor, I hereby declare that:

My residence, post office address and citizenship are stated below next to my name:

I believe I am an original, first and joint inventor the subject matter which is claimed and for which a patent is sought on the invention entitled **POINT-TO-POINT INTERNET PROTOCOL**, the specification of which was filed on September 25, 1995 under Attorney's Docket Number N0003/7000, now U.S. Patent Application Serial No. 08/533,115.

I hereby state that I have reviewed and understand the contents of the above identified patent application, including the claims as amended by any amendment referred to above.

I acknowledge the duty to disclose information which is material to the patentability of this application in accordance with 37 C.F.R. 1.56.

I hereby claim the benefit of foreign priority under 35 U.S.C. 119 of any foreign application(s) for patent or inventor's certificate having a filing date before that of the application the priority of which is claimed:

Prior Foreign Application(s):	Priority Claimed
_____	_____ Yes _____ No
(Number)	
_____	_____
(Country)	(Filing Date)

I hereby claim the benefit of United States priority under 35 U.S.C. 120 of any United States application(s) listed below and, insofar as the subject matter of each of the claims of this application is not disclosed in a listed prior United States application in the manner provided by the first paragraph of 35 U.S.C. 112, I acknowledge the duty to disclose information material to the patentability of this application as defined in 37 C.F.R. 1.56 which occurred between the filing date of the prior application and the national or PCT international filing date of this application.

_____	_____	_____
(Application Serial #)	(Filing Date)	(Status)
_____	_____	_____
(Application Serial #)	(Filing Date)	(Status)
_____	_____	_____
(Application Serial #)	(Filing Date)	(Status)

I hereby declare that all statements made herein of my own knowledge are true and that all statements made on information and belief are believed to be true; and further that these statements were made with the knowledge that willful false statements and the like so made are punishable by fine or imprisonment, or both, under 18 U.S.C. 1001 and that such willful false statements may jeopardize the validity of the application or any patent issued thereon.

POWER OF ATTORNEY: As a named inventor, I hereby appoint the following attorneys and/or agents to prosecute this application and transact all business in the Patent and Trademark Office connected therewith.

Bruce D. Jobse	Reg. No. 33,518	Paul E. Kudirka	Reg. No. 26,931
Arthur Z. Bookstein	Reg. No. 22,958	John F. Perullo	Reg. No. 36,265
Philip L. Conrad	Reg. No. 34,567	Steven G. Saunders	Reg. No. 36,265
Paul J. Cook	Reg. No. 20,280		

Send correspondence to Bruce D. Jobse, BOOKSTEIN & KUDIRKA, P.C., One Beacon Street, Boston, Massachusetts, 02108.

FULL NAME OF INVENTOR: Glenn W. Hutton

INVENTOR'S SIGNATURE: \_\_\_\_\_ DATE: \_\_\_\_\_

RESIDENCE: 9725 Hammocks Boulevard, #206, Miami, FL 33196  
CITIZENSHIP: Canada  
POST OFFICE ADDRESS: 9725 Hammocks Boulevard, #206, Miami, FL 33196

---

---

FULL NAME OF INVENTOR: Shane D. Mattaway

INVENTOR'S SIGNATURE:  DATE: 1/3/97

RESIDENCE: 826 Periwinkle, Boca Raton, FL 33486  
CITIZENSHIP: U.S.A.  
POST OFFICE ADDRESS: 826 Periwinkle, Boca Raton, FL 33486

---

---

FULL NAME OF INVENTOR: Craig B. Strickland

INVENTOR'S SIGNATURE:  DATE: 1/3/97

RESIDENCE: 5713 NW 65th Terrace, Tamarac, FL 33321  
CITIZENSHIP: Canada  
POST OFFICE ADDRESS: 5713 NW 65th Terrace, Tamarac, FL 33321

H:\BDJN0003\7000\DECL.WPD



ATTORNEY'S DOCKET NO.: N0003/7000

THE UNITED STATES PATENT AND TRADEMARK OFFICE


APPLICANT: Shane D. Mattaway et al.  
SERIAL NO.: 08/533,115  
FILED: September 25, 1995  
FOR: POINT-TO-POINT INTERNET PROTOCOL  
EXAMINER:  
ART UNIT: 2302

RECEIVED  
MAY 13 97  
GROUP 2600

---

CERTIFICATE OF MAILING UNDER 37 C.F.R. §1.8(a)

The undersigned hereby certifies that this document is being placed in the United States mail with first-class postage attached, addressed to Assistant Commissioner for Patents, Washington, DC 20231 on the 17th day of April, 1997.

  
Frances M. Cunningham

---

Assistant Commissioner for Patents  
Washington, D.C. 20231

Sir:

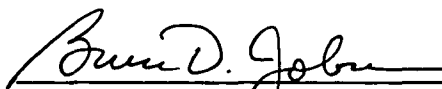
Transmitted herewith for filing are the following documents:

- Declaration and Power of Attorney (2)
- Assent of Assignee
- Petition to Add to Originally Named Inventor(s)
- Statement of Facts

If the enclosed papers are considered incomplete, the Mail Room and/or the Assignment Branch is respectfully requested to contact the undersigned collect at (617) 367-4600, Boston, Massachusetts.

A check in the amount of \$130.00 is enclosed for filing of Petition to Add to Originally Named Inventor(s). If the fee is insufficient, the balance may be charged to the account of the undersigned, Deposit Account No. 02-3038. A duplicate of this sheet is enclosed.

Respectfully submitted,

  
Bruce D. Jobse, Esq.

Reg. No.: 33,518  
BOOKSTEIN & KUDIRKA, P.C.  
One Beacon Street  
Boston, Massachusetts 02108  
Tel.: (617) 367-4600

April 17, 1997

=> d his

(FILE 'USPAT' ENTERED AT 13:03:05 ON 16 MAY 1997)

L1 0 S MENG/XP  
L2 0 S (MENG?)/XP  
E AN/XP  
L3 82 S E4-E8  
L4 3023 S 395/800/CCLS  
L5 26 S L3 NOT L4  
L6 1 S L5 AND (BROWSER OR INTERNET OR (WORLD WIDE WEB))  
L7 6 S (BROWSER OR INTERNET OR (WORLD WIDE WEB))  
L8 0 S L5 AND (BROWSER AND INTERNET AND (WORLD WIDE WEB))  
L9 3 S (BROWSER AND INTERNET AND (WORLD WIDE WEB))  
L10 6 S WORLD WIDE WEB AND BROWSER





**UNITED STATES DEPARTMENT OF COMMERCE  
Patent and Trademark Office**

Address: COMMISSIONER OF PATENTS AND TRADEMARKS  
Washington, D.C. 20231

APPLICATION NO.	FILING DATE	FIRST NAMED INVENTOR	ATTORNEY DOCKET NO.
08/533,115	09/25/95	HUTTON	G 649-2

BOOSTEIN & KUDIRKA, PC  
ONE BEACON STREET  
BOSTON MA 02108

B3M1/0602

EXAMINER GREGSON, R
------------------------

ART UNIT	PAPER NUMBER
2302	10

DATE MAILED: 06/02/97

**Please find below and/or attached an Office communication concerning this application or proceeding.**

**Commissioner of Patents and Trademarks**

**Office Action Summary**

Application No.  
**08/533,115**

Applicant(s)  
**Hutton**

Examiner  
**Richard J. Gregson**

Group Art Unit  
**2302**



Responsive to communication(s) filed on 25 Sep 1995

This action is **FINAL**.

Since this application is in condition for allowance except for formal matters, **prosecution as to the merits is closed** in accordance with the practice under *Ex parte Quayle*, 1935 C.D. 11; 453 O.G. 213.

A shortened statutory period for response to this action is set to expire 3 month(s), or thirty days, whichever is longer, from the mailing date of this communication. Failure to respond within the period for response will cause the application to become abandoned. (35 U.S.C. § 133). Extensions of time may be obtained under the provisions of 37 CFR 1.136(a).

**Disposition of Claims**

Claim(s) 1-53 is/are pending in the application.

Of the above, claim(s) \_\_\_\_\_ is/are withdrawn from consideration.

Claim(s) \_\_\_\_\_ is/are allowed.

Claim(s) 1-53 is/are rejected.

Claim(s) \_\_\_\_\_ is/are objected to.

Claims \_\_\_\_\_ are subject to restriction or election requirement.

**Application Papers**

See the attached Notice of Draftsperson's Patent Drawing Review, PTO-948.

The drawing(s) filed on \_\_\_\_\_ is/are objected to by the Examiner.

The proposed drawing correction, filed on \_\_\_\_\_ is  approved  disapproved.

The specification is objected to by the Examiner.

The oath or declaration is objected to by the Examiner.

**Priority under 35 U.S.C. § 119**

Acknowledgement is made of a claim for foreign priority under 35 U.S.C. § 119(a)-(d).

All  Some\*  None of the CERTIFIED copies of the priority documents have been  
 received.

received in Application No. (Series Code/Serial Number) \_\_\_\_\_

received in this national stage application from the International Bureau (PCT Rule 17.2(a)).

\*Certified copies not received: \_\_\_\_\_

Acknowledgement is made of a claim for domestic priority under 35 U.S.C. § 119(e).

**Attachment(s)**

Notice of References Cited, PTO-892

Information Disclosure Statement(s), PTO-1449, Paper No(s). 6

Interview Summary, PTO-413

Notice of Draftsperson's Patent Drawing Review, PTO-948

Notice of Informal Patent Application, PTO-152

--- SEE OFFICE ACTION ON THE FOLLOWING PAGES ---

**Part III DETAILED ACTION**

1. Claims 1-53 are presented for examination.
  
2. A shortened statutory period for response to this action is set to expire three (3) months from the date of mailing of this communication. Failure to respond within the period for response will cause the application to become abandoned. (35 U.S.C. § 133). Extensions of time may be obtained under the provisions of 37 CFR 1.136(a).

*Information Disclosure Statement*

3. In view of the extremely large number of references submitted by the Applicant(s) for consideration of this application, the Applicant(s) are requested to identify any references which have particular significance in the prosecution of this application for further consideration by the Examiner. Applicant(s) should also indicate the specific features, corresponding passages, and figures of such references which are believed to be germane to the invention claimed in the application

*Specification*

4. The title of the invention is not descriptive. A new title is required that is clearly indicative of the invention to which the claims are directed.
  
5. The lengthy specification has not been checked to the extent necessary to determine the presence of all possible minor errors. Applicant's cooperation is requested in correcting any errors of which applicant may become aware in the specification.

*Claim Rejections - 35 USC § 103*

6. The following is a quotation of 35 U.S.C. § 103 which forms the basis for all obviousness rejections set forth in this Office action:

A patent may not be obtained though the invention is not identically disclosed or described as set forth in section 102 of this title, if the differences between the subject matter sought to be patented and the prior art are such that the subject matter as a whole would have been obvious at the time the invention was made to a person having ordinary skill in the art to which said subject matter pertains. Patentability shall not be negated by the manner in which the invention was made.

Subject matter developed by another person, which qualifies as prior art only under subsection (f) or (g) of section 102 of this title, shall not preclude patentability under this section where the subject matter and the claimed invention were, at the time the invention was made, owned by the same person or subject to an obligation of assignment to the same person.

7. Claims 1-4 are rejected under 35 U.S.C. § 103 as being unpatentable over Civanlar, et al, (US 5,581,552) in view of Morgan, et al., (US 5,524,254). The claimed invention found within Claim 1 consists of a method for establishing point-to-point Internet communications comprising (a) storing in a database a set of IP addresses for on-line nodes, (b) transmitting a query from a node to a server to determine the status of a second node, and <sup>©</sup> retrieving the IP address of the second node from the database in to establish communication between the two nodes. Civanlar, et al., in 2-3, teaches a multimedia server which uses a communication protocol in which the requesting node sends a request for communication with another node through a address server, which contains an address database, to obtain the address and routing information necessary to complete the communication. Civanlar, et al., is silent regarding the database searching to match the address with the destination node. Morgan, et al, in columns in columns 3-4, teaches the look-up procedure into the database which is performed to retrieve the matching address from the database for use in initiating communications over an network.

Art Unit: 2302

It would have been obvious to one of ordinary in the art at the time the claimed invention was made to include an database and search/retrieval mechanism to locate the needed network address because such a mechanism permits the database to be modified over time to allow dynamic address assignment thus reducing the need to larger address identifiers and thus the amount of data that needs to be transmitted with each packet of data.

Regarding Claim 2, the claimed invention adds the further limitation to the invention found within Claim 1 that steps of obtaining the on-line status and IP address of the second node include the steps of: (b1) sending a query to a server, (c1) searching the server's database, (c2) determining the on-line status of the second node, (c3) retrieving the IP address of the second node, (c4) and transmitting the IP address of the second node from the server to the requesting node. As was discussed above regarding Claim 1, Morgan, et al., in columns 3-4, teaches the look-up procedure into the database which is performed to retrieve the matching address from the database for use in initiating communications over an network. It would have been obvious to one of ordinary in the art at the time the claimed invention was made to include an database and search/retrieval mechanism to locate the needed network address because such a mechanism permits the database to be modified over time to allow dynamic address assignment thus reducing the need to larger address identifiers and thus the amount of data that needs to be transmitted with each packet of data.

Regarding Claim 3 and 4, the claimed invention in Claim 3 adds the further limitation to the invention found within Claim 2 that the claimed process generate and transmit an error message which is sent to the requesting node when the second node's status is off-line. The claimed invention Claim 4 adds the further limitation to the invention found within Claim 1 that secondary communications protocol is used when a off-line status is found. Morgan, et al., in columns 13-14 teaches the process of handling

Art Unit: 2302

error condition where the requested second node is not available, that the processing terminates gracefully. Implicit within this operation is the transmittal of appropriate messages to the requesting node of this condition with the initiation of error recovery procedures..

8. Claims 5 and 12-16 are rejected under 35 U.S.C. 103 as being unpatentable over Civanlar, et al, (US 5,581,552) in view of Morgan, et al., (US 5,524,254) as applied to claims 1-5 above, and further in view of December, et al. (The World Wide Web Unleased) . The claimed invention in Claim 5 adds the further limitation to the invention found within Claim 4 that performing the secondary communication protocol includes (d1) transmitting an e-mail signal over Internet from the first node with its IP address, (d2) transmitting the message thru the Internet for delivery at the second node, and (d3) transmitting a second IP address to the first node for establishing the point-to-point communications. The combination of Civanlar, et al., and Morgan, et al. teaches the communications mechanism claimed here in utilizing the address server and its database to initiate communications between the two nodes. Neither of these two references teaches the message transport mechanism which is utilized to transmit the various messages between the various processors on the network. December, et al., on pages 6-9 teaches the various message and data types which are readily transported between two nodes attached to the Internet and that each type of message is a format for which blocks of data are sent between different processors. It would have been obvious to one of ordinary skill in the art at the time the claimed invention was made to utilize Internet e-mail messages as the means to transport various requests between two processors attached to the Internet because it is a well defined and well supported data transport means for moving data between processors across the Internet and that the substitution of e-mail as the transport mechanism

for any other message transport means would be within the ordinary skill of the art as these transport means are equivalent means for moving blocks of data between nodes of the network.

Regarding Claim 12, the claimed invention consists of an independent method claim for establishing point-to point communications comprising transmitting an e-mail signal from the first node via the Internet to the second node, each message containing the appropriate IP address to establish, and using these addresses to establish the point-to-point communication. The claimed invention is a simplified version of the method contained within Claim 1 above with the specification that the messages used to communicate between the first and second nodes be transported using e-mail. The combination of Civanlar, et al., and Morgan, et al. teaches the communications mechanism claimed here in utilizing the address server and its database to initiate communications between the two nodes. Neither of these two references teaches the message transport mechanism which is utilized to transmit the various messages between the various processors on the network. December, et al., on pages 6-9 teaches the various message and data types which are readily transported between two nodes attached to the Internet and that each type of message is a format for which blocks of data are sent between different processors. It would have been obvious to one of ordinary skill in the art at the time the claimed invention was made to utilize Internet e-mail messages as the means to transport various requests between two processors attached to the Internet because it is a well defined and well supported data transport means for moving data between processors across the Internet and that the substitution of e-mail as the transport mechanism for any other message transport means would be within the ordinary skill of the art as these transport means are equivalent means for moving blocks of data between nodes of the network.

Regarding Claim 13 and 14, the claimed invention adds the further limitation to the invention found within Claim 12 that the process of transmitting the appropriate email signal includes the first step

of generating the signal to be sent before it is transmitted. Implicit within the teaching of Cinvanlar, et al. is the step of generating all messages that need to be transmitted to other processors before the message is transmitted using its particular transport means.

Regarding Claim 15, the claimed invention adds the further limitation to the invention found within Claim 12 that processing the e-mail message for delivery thru the Internet consists of the processing the e-mail message using the e-mail server connected to the second processor. Implicit with the teachings of December, et al. is the existence of processes running at both nodes of the Internet that are communicating, which includes the e-mail function, to perform the steps necessary to allow the communication to occur. As such, the transmission of data between two nodes must include the use of a process like a mail server to operate at the receiving end of the communication in order for the communication to be successful. It would have been obvious to one of ordinary skill in the art at the time the claimed invention was made to utilize Internet e-mail messages on regularly supported e-mail servers as the means to transport various requests between two processors attached to the Internet because it is a well defined and well supported data transport means for moving data between processors across the Internet and that the substitution of e-mail as the transport mechanism for any other message transport means would be within the ordinary skill of the art as these transport means are equivalent means for moving blocks of data between nodes of the network.

Regarding Claim 16, the claimed invention adds the further limitation to the invention found within Claim 12 that step of processing the e-mail signal followed by transmitting a second IP address include the steps of generating a connection signal which is transmitted to the first node along with the second IP address. Civanlar, et al., in column 11, teaches the use of a signal to initiate the connection between the two nodes along with the all necessary address information needed by the nodes. December,



et al., teaches that the communication of these messages can be accomplished using e-mail over the Internet. It would have been obvious to one of ordinary skill in the art at the time the claimed invention was made to utilize Internet e-mail messages as the means to transport various requests between two processors attached to the Internet because it is a well defined and well supported data transport means for moving data between processors across the Internet and that the substitution of e-mail as the transport mechanism for any other message transport means would be within the ordinary skill of the art as these transport means are equivalent means for moving blocks of data between nodes of the network.

9. Claim 6, which teaches an apparatus claims, fail to teach or define above or beyond Claims 1-5 above and are rejected for the same reasons set forth above in the rejections of Claims 1-5, supra.

10. Claims 7-11, which also teaches a set of apparatus claims, fail to teach or define above or beyond Claims 1-5 above and are rejected for the same reasons set forth above in the rejections of Claims 1-5, supra.

11. Claims 17-18, which teaches a set of apparatus claims, fail to teach or define above or beyond the apparatus found within Claims 12-16 above and are rejected for the same reasons set forth above in the rejections of Claims 12-16, supra.

12. Claims 19-20, which also teaches a set of apparatus claims, fail to teach or define above or beyond the apparatus found within Claims 12-16 above and are rejected for the same reasons set forth above in the rejections of Claims 12-16, supra.

13. Claim 21, which teaches a computer program product claim, fail to teach or define above or beyond Claims 1-5 above and are rejected for the same reasons set forth above in the rejections of Claims 1-5, supra.

14. Claim 22, which teaches a computer program product claim, fail to teach or define above or beyond Claims 12-16 above and are rejected for the same reasons set forth above in the rejections of Claims 12-16, supra.

15. Claims 23-25, which also teaches a set of apparatus claims, fail to teach or define above or beyond Claims 1-5 above and are rejected for the same reasons set forth above in the rejections of Claims 1-5, supra.

16. Claims 26-31, which teaches a set of method claims, fail to teach or define above or beyond the apparatus found within Claims 1-5 above and are rejected for the same reasons set forth above in the rejections of Claims 1-5, supra.

17. Claims 32-42, which also teaches a set of method claims, fail to teach or define above or beyond the apparatus found within Claims 12-16 above and are rejected for the same reasons set forth above in the rejections of Claims 12-16, supra.

18. Claims 43-53, which teaches a set of computer program product claims, fail to teach or define above or beyond the apparatus found within Claims 12-16 above and are rejected for the same reasons set forth above in the rejections of Claims 12-16, supra.

*Conclusion*

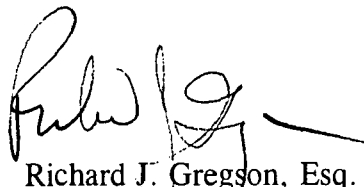
19. The prior art made of record and not relied upon is considered pertinent to applicant's disclosure:

a. Heylighen teaches the basics of Internet communication and the addressing means used therein.

20. Any inquiry concerning this communication or earlier communications from the examiner should be directed to Richard J. Gregson whose telephone number is (703) 305-4392. The examiner can normally be reached on Monday-Thursday from 8:00 a.m. to 5:30 p.m., as well as on alternate Fridays during these same hours.

If attempts to reach the examiner by telephone are unsuccessful, the examiner's supervisor, Alyssa H. Bowler, can be reached on (703) 305-9702. The fax phone number for this Group is (703) 308-5358.

Any inquiry of a general nature or relating to the status of this application or proceeding should be directed to the Group receptionist whose telephone number is (703) 305-9700.

  
Richard J. Gregson, Esq.  
Patent Examiner  
Art Unit 2302

  
MARK H. RINEHART  
PATENT EXAMINER  
GROUP 2300



May 22, 1997

**Notice of References Cited**

Application No. <b>08/533,115</b>	Applicant(s) <b>Hutton</b>	
Examiner <b>Richard J. Gregson</b>	Group Art Unit <b>2302</b>	Page 1 of 1

**U.S. PATENT DOCUMENTS**

	DOCUMENT NO.	DATE	NAME	CLASS	SUBCLASS
A	5,581,552	12/96	Civanlar, et al.	370	396
B	5,524,254	6/96	Morgan, et al.	395	500
C					
D					
E					
F					
G					
H					
I					
J					
K					
L					
M					

**FOREIGN PATENT DOCUMENTS**

	DOCUMENT NO.	DATE	COUNTRY	NAME	CLASS	SUBCLASS
N						
O						
P						
Q						
R						
S						
T						

**NON-PATENT DOCUMENTS**

	DOCUMENT (Including Author, Title, Source, and Pertinent Pages)	DATE
U	December & Randall, "The World Wide Web Unleashed," Samw Publishing, Indianapolis, IN, 1994, pp. 3-24.	12/94
V	Heylighen, "WorldWideWeb: a distributed hypermedia paradigm for global networking," IEE/INSPEC Database Updates and Additionss (1960-19950 Doc.# 1374618: Proceedings SHARE Spring Conference, pp. 355-368.	4/94
W		
X		

Form PTO-1449  
 INFORMATION  
 DISCLOSURE  
 STATEMENT

Docket No.: N0003/7000

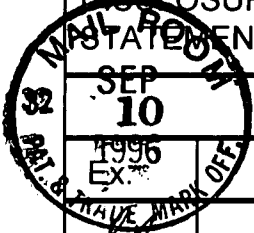
Serial No. 08/533,115

Applicant: Glenn W. Hutton

Filed: September 25, 1995

Group:

U.S. Patent Documents



1996 EX.	Doc. No.	Date	Name	Class	Subcl.	Filed
RB	5 3 0 9 4 3 7	5/3/94	Perlman et al.	—	—	
RB	5 4 4 2 6 3 3	8/15/95	Perkins et al.	—	—	
RB	5 1 6 6 9 3 1	11/24/92	Riddle	—	—	
RB	5 4 5 7 6 8 3	10/10/95	Robins	—	—	
RB	5 4 6 9 5 0 0	11/21/95	Satter et al.	—	—	
RB	5 4 5 2 2 9 6	9/19/95	Shimizu	—	—	
RB	5 4 6 3 6 2 5	10/31/95	Yasrebi	—	—	

Foreign Patent Documents

Ex.	Doc. No.	Date	Name	Class	Subcl.

OTHER DOCUMENTS (including, Author, Title, Date, Pages, Etc.)


Examiner: *[Signature]*

Date considered *5/22/97*

EXAMINER: Initial if citation considered, whether or not citation is in conformance with MPEP 609; Draw line through citation if not in conformance and not considered. Include copy of this form with next communication to applicant. An \* indicates references that do not require a copy to be provided under 37 C.F.R. §1.98(d) because a copy was previously cited or submitted in a prior application, which is relied upon under 35 U.S.C. §120.

#6



Form PTO-1449 INFORMATION DISCLOSURE STATEMENT	Docket No.: N0003/7000	Serial No. 08/533,115
	Applicant: Glenn W. Hutton	
	Filed: September 25, 1995	Group: GROUP 2300

RECEIVED  
SEP 16 1996

U.S. Patent Documents

Ex.	Doc. No.	Date	Name	Class	Subcl.	Filed
<i>PR</i>	5 5 4 6 5 8 2	8/13/96	Brockmeyer et al.	—	—	
<i>PR</i>	5 4 3 0 7 2 7	7/4/95	Callon	—	—	
<i>PR</i>	5 5 2 4 1 1 0	6/4/96	Danneels et al.	—	—	
<i>PR</i>	5 0 9 5 4 8 0	3/10/92	Fenner	—	—	
<i>PR</i>	5 4 3 0 7 0 9	7/4/95	Galloway	—	—	
<i>PR</i>	5 5 1 7 4 9 4	5/14/96	Green	—	—	
<i>PR</i>	5 4 7 9 4 1 1	12/26/95	Klein	—	—	
<i>PR</i>	5 5 4 4 3 0 3	8/6/96	Mraoteaux et al.	—	—	
<i>PR</i>	5 5 2 6 4 8 9	6/11/96	Nilakantan et al.	—	—	
<i>PR</i>	5 5 3 3 1 1 0	7/2/96	Pinard et al.	—	—	

Foreign Patent Documents

Ex.	Doc. No.	Date	Name	Class	Subcl.	Filed

OTHER DOCUMENTS (including, Author, Title, Date, Pages, Etc.)


Examiner: *Richard Gregson*      Date considered *5/22/97*

EXAMINER: Initial if citation considered, whether or not citation is in conformance with MPEP 609; Draw line through citation if not in conformance and not considered. Include copy of this form with next communication to applicant. An \* indicates references that do not require a copy to be provided under 37 C.F.R. §1.98(d) because a copy was previously cited or submitted in a prior application, which is relied upon under 35 U.S.C. §120.



GP 2302

N0003/7000  
PATENT

#13

CERTIFICATE OF MAILING

I hereby certify that the following Transmittal Letter is being deposited with the United States Postal Service as First Class Mail in an envelope addressed to the Assistant Commissioner for Patents, Box DD, Washington, D.C. 20231 on July 11, 1997.

*Frances M. Cunningham*  
Frances M. Cunningham

Assistant Commissioner for Patents  
Box DD  
Washington, DC 20231

TRANSMITTAL LETTER

Sir:

Transmitted herewith for filing in the Patent Application of:

Applicant: Glenn W. Hutton  
Serial No.: 08/533,115  
Filed: September 25, 1995  
For: POINT-TO-POINT INTERNET PROTOCOL  
Examiner: R. Gregson  
Art Unit: 2302

RECEIVED  
AUG - 1 97  
GROUP 2600

are the following papers:

X Information Disclosure Statement, Form PTO-1449 and references.

The Commissioner is hereby authorized to charge any other fees under 37 C.F.R. §§1.16 and 1.17 that may be required, or credit any overpayment, to our Deposit Account No. 02-3038.

Respectfully submitted,

*Bruce D. Jobse*

Bruce D. Jobse, Reg. No. 33,518  
BOOKSTEIN & KUDIRKA, P.C.  
One Beacon Street  
Boston, MA 02108  
(617) 367-4600

H:\BDJ\N0003\7000\IDS3TRA.WPD



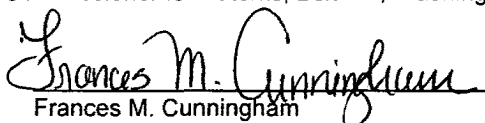
N0003/7000

IN THE UNITED STATES PATENT AND TRADEMARK OFFICE

Applicant: Glenn W. Hutton  
Serial No.: 08/533,115  
Filed: September 25, 1995  
For: POINT-TO-POINT INTERNET PROTOCOL  
Examiner: R. Gregson  
Art Unit: 2302

CERTIFICATE OF MAILING UNDER 37 C.F.R. §1.8(a)

The undersigned hereby certifies that this document is being placed in the United States mail with first-class postage attached, addressed to Assistant Commissioner for Patents, Box DD, Washington, DC 20231 on July 11, 1997.

  
Frances M. Cunningham

Assistant Commissioner for Patents  
Box DD  
Washington, DC 20231

RECEIVED  
AUG - 1 97  
GROUP 2600

**STATEMENT FILED PURSUANT TO THE DUTY OF  
DISCLOSURE UNDER 37 C.F.R. §§1.56, 1.97 AND 1.98**

Sir:

Pursuant to the duty of disclosure under 37 C.F.R. §§1.56, 1.97 and 1.98, the applicant requests consideration of this Information Disclosure Statement.

This Information Disclosure Statement is being filed before the mailing date of a first Office Action on the merits and thus no certification is required.

The undersigned hereby certifies that each item of Information contained in the attached Information Disclosure Statement was cited in a communication from a foreign patent office in a counterpart foreign application mailed not more than three months prior to the filing of this Statement. Each item was cited in Annex to Form PCT/ISA/206, Communication Relating to the Results of the Partial International Search mailed June 13, 1997, in International Application No. PCT/US 96/15504, filed September 25, 1996.

The applicant hereby makes of record in the above-identified application the information listed on the attached form PTO-1449 (modified). The order of presentation



of the references should not be construed as an indication of the relative importance of the references.

### Remarks

A copy of each of the above-identified information items is enclosed. It is respectfully requested that:

- The examiner consider completely the cited information, along with any other information, in reaching a determination concerning the patentability of the present claims;
- The enclosed form PTO-1449 be signed by the examiner to evidence that the cited information has been fully considered by the Patent and Trademark Office during the examination of this application;
- The citations for the information be printed on any patent which issues from this application.

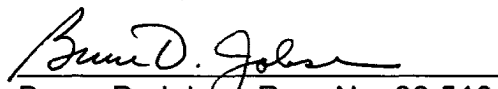
By submitting this information disclosure statement, the applicant makes no representation that a search has been performed, of the extent of any search performed, or that more relevant information does not exist.

By submitting this information disclosure statement, the applicant makes no representation that the information cited in the statement is, or is considered to be, material to patentability as defined in 37 C.F.R. §1.56(b).

By submitting this information disclosure statement, the applicant makes no representation that the information cited in the statement is, or is considered to be, in fact, prior art as defined by 35 U.S.C. §102.

It is understood by applicant that the foregoing information will be considered and, to the extent deemed appropriate by the examiner, will be reflected in the examiner's communication.

Respectfully submitted,

  
Bruce D. Jobse, Reg. No. 33,518  
BOOKSTEIN & KUDIRKA, P.C.  
One Beacon Street  
Boston, Massachusetts 02108  
Tel: (617) 367-4600



11/13

12)

**EUROPEAN PATENT APPLICATION**

21) Application number : 91303643.0

51) Int. Cl.<sup>5</sup> : **H04L 12/24**

22) Date of filing : **23.04.91**

30) Priority : **03.05.90 US 519187**

43) Date of publication of application :  
**06.11.91 Bulletin 91/45**

84) Designated Contracting States :  
**DE FR GB**

71) Applicant : **Hewlett-Packard Company**  
**Mail Stop 20 B-O, 3000 Hanover Street**  
**Palo Alto, California 94304 (US)**

72) Inventor : **Wu, Jeff C.**  
**2630 Wapiti Road**  
**Fort Collins, Colorado 80525 (US)**

74) Representative : **Colgan, Stephen James et al**  
**CARPMAELS & RANSFORD 43 Bloomsbury**  
**Square**  
**London WC1A 2RA (GB)**

54) **Automatic discovery of network elements.**

57) Disclosed is a computer network node discovery system that provides a general way of discovering network elements, or nodes, connected to a computer network, and a specific algorithm for discovering nodes connected to a TCP/IP network, using the SNMP protocol available within the TCP/IP network software. Some nodes on a network, called discovery agents, can convey knowledge of the existence of other nodes on the network. The network discovery system queries these agents and obtains the information they have about other nodes on the network. It then queries each of the nodes obtained to determine if that node is also a discovery agent. In this manner, most of the nodes on a network can be discovered. The process of querying discovery agents to obtain a list of nodes known to the discovery agents is repeated at timed intervals to obtain information about nodes that are not always active. In a TCP/IP network, discovery agents are nodes that respond to queries for an address translation table which translates internet protocol (IP) addresses to physical addresses. The data from each node's address translation table is used to obtain both the IP and the physical address of other nodes on the network. These nodes are then queried to obtain additional information. After all the nodes on a network are discovered, the list of nodes is written to a database where it can be displayed by the network manager or other users of the network.

**EP 0 455 402 A2**

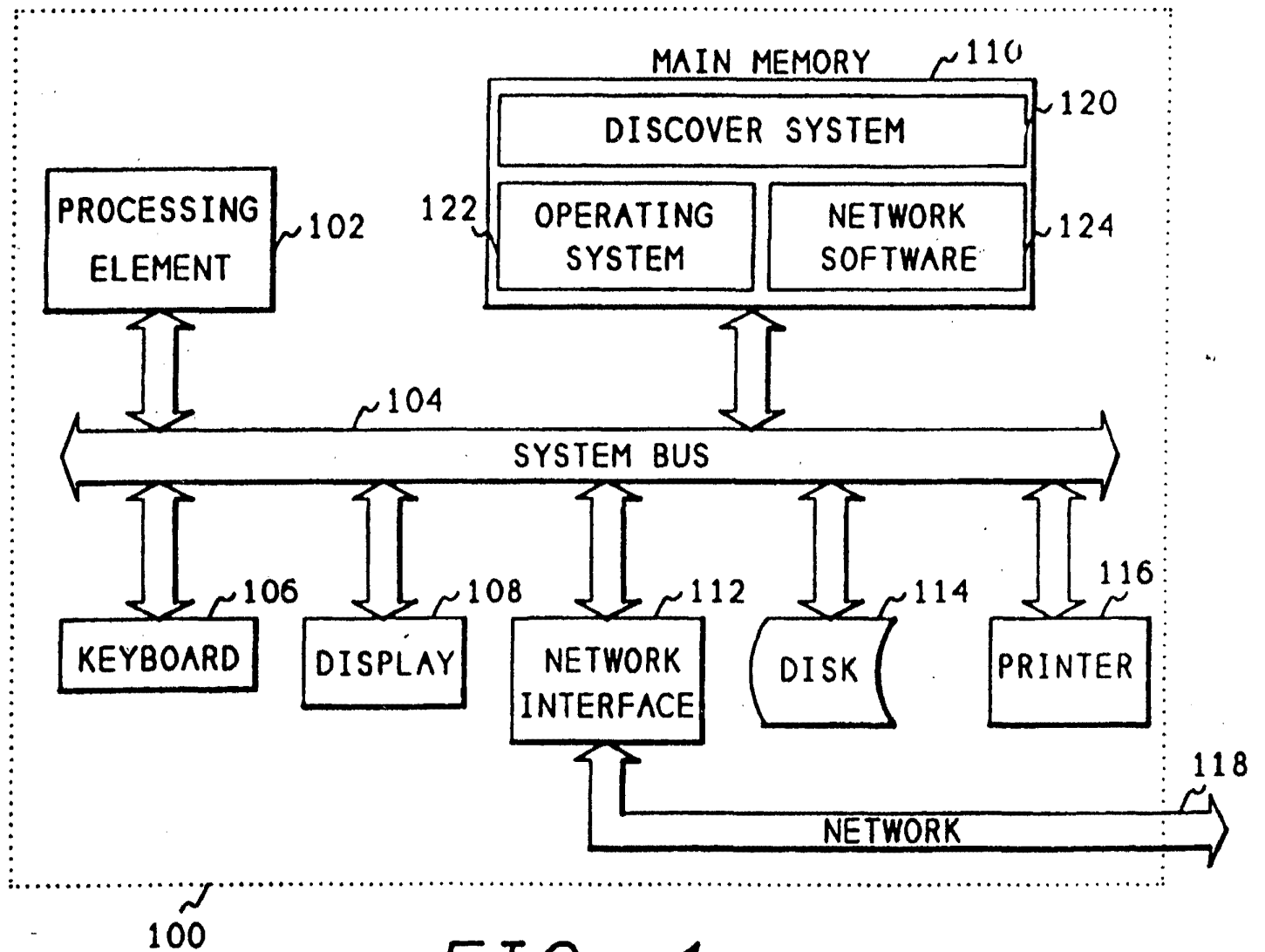


FIG. 1

## FIELD OF THE INVENTION

This invention relates to computer systems and more particularly to computer networks that interconnect computers. Even more particularly, the invention relates to determining the nodes connected to a network.

## BACKGROUND OF THE INVENTION

Computer networks are collections of hardware and software that connect computers and allow them to send information from one computer to another electronically. A computer network is comprised of the physical hardware connections between the various computers, for example telephone lines or a coax cable, and the software used to send and receive data and to route the data to the selected computer on the network.

A local area network (LAN) is a network connection between computers in close proximity, typically less than one mile, and usually connected by a single cable such as coax cable. A wide area network (WAN) is a network of computers located at longer distances, often connected by telephone lines or satellite links. Network software may sometimes be used with both types of networks. For example, a popular network is the Department of Defense internetworking protocol suite, known as Transmission Control Protocol/Internet Protocol (TCP/IP). This system was originally developed by the Defense Advanced Research Projects Agency (DARPA) and has now been widely distributed to Universities and industry.

When a network is fast growing, that is, network elements or nodes are being added frequently, a network administrator may not know all of the nodes connected to the network. Also, a network administrator new to his or her job may not be familiar with the nodes on the network. Determining the nodes manually is a difficult problem. The administrator may contact all the users of the network known to the administrator, however, infrequent users may be forgotten and not contacted. Also, if a node is connected to the network, but not active because the computer is not powered up or is inoperative, that node may not be included in the list. In a very short local area network, a network administrator may physically trace the cable of the network to determine which nodes are located on the network. However, since longer local area networks can extend as far as a mile, through many floors and offices within a building, physical tracing may be impossible. In a wide area network, physical tracing is almost always impossible.

For some commonly used networks, special equipment can be purchased that will determine the nodes located on the network and the distance between them. This equipment, called a probe, is often limited by the other components of the network, how-

ever. For example, in a local area network, a repeater unit may be used to extend the effective distance of the local area network to a distance greater than is capable with a single cable. A repeater unit amplifies signals, and therefore will not allow a probe to determine the location of nodes beyond the repeater.

Other units connected to the network may obscure nodes. For example a bridge unit connects two similar networks but only passes messages that are being sent from a node on one side of the bridge to a node on the other side of the bridge. It will not pass messages between nodes on the same side, in order to reduce the traffic on the other side of the bridge. A bridge will prevent a probe from determining the nodes on the other side of the bridge. A gateway is a unit that connects dissimilar networks to pass messages. Because a gateway may have to reformat a message to accommodate a different network protocol, it will prevent a probe from finding nodes beyond the gateway.

There is need in the art then for a method of determining the nodes on a local area network. There is further need in the art for determining such nodes without the use of special equipment. A still further need is for a method that will determine which nodes are located beyond the repeater units, bridges, and gateways on a network.

## SUMMARY OF THE INVENTION

It is an object of the present invention to provide a method of determining the elements or nodes connected to a network.

It is another object of the invention to provide a method of discovering network nodes on a TCP/IP network.

Another object of the invention is to determine which discovered nodes are discovery agents and can convey knowledge of the existence of other nodes on the network.

Another object is to query all discovery agents and ask for other nodes on the network

A further object is to query all TCP/IP nodes to retrieve the address translation table from the TCP/IP node.

The above and other objects of the invention are accomplished in a system which provides a general way of discovering network elements, or nodes, and a specific algorithm for discovering nodes within a TCP/IP network, using a standard Simple Network Management Protocol (SNMP), which is available within the TCP/IP network.

Some nodes on a network can convey knowledge of the existence of other nodes on a network, and are called discovery agents. When a network contains discovery agents, these agents can be queried to obtain the information they have about other nodes on the network. By obtaining a list of nodes from a single

discovery agent, and querying each of the nodes obtained to determine if it is also a discovery agent, most of the nodes on a network can be discovered.

The process of querying discovery agents to obtain a list of nodes known to be discovery agents, must be repeated at timed intervals. At any given time on a network, one or more nodes may not be responding to the network, either because it is inoperative, or because it is not powered up. Therefore, if the discovery process is attempted during this time, these unavailable nodes will not be discovered. By repeating the discovery process over time at regular intervals, additional nodes on a network can be discovered.

In a TCP/IP network, discovery agents are nodes that respond to queries for an address translation table. Within TCP/IP network, every node will have an internet protocol (IP) address. This address is a 32 bit number and is unique to all nodes within the TCP/IP network. Although the IP address is probably unique to all nodes everywhere that use the TCP/IP protocol, the physical address of a node on a particular network will be different from the IP address. For example, some types of LANs use an 8 bit address, and can therefore use the low order 8 bits of the IP address, however, some other types of LANs use a 48 bit address and cannot use the internet address. Therefore, every node within a TCP/IP network must have an address translation table which translates the IP address to the physical address. The data from each node's address translation table can be used to obtain both the IP and the physical address of other nodes on the network. Again, as described in the above general algorithm, the queries should be repeated at timed intervals to insure that recently activated nodes are discovered. Another reason for repeating the discovery process over timed intervals in a TCP/IP network is that some of the information within a node's address translation table may be purged if the node does not use the information after a period of time. This purge is used to reduce the table size requirements within a node. By repeating the queries at timed intervals, the greatest amount of translation table information may be obtained.

#### BRIEF DESCRIPTION OF THE DRAWINGS

The above and other objects, features, and advantages of the invention will be better understood by reading the following more particular description of the invention, presented in conjunction with the following drawings, wherein:

Fig. 1 shows a block diagram of the hardware of the node that runs the process of the present invention;

Fig. 2 shows a diagram of a typical computer interconnection network;

modules of the discovery system of the present invention;

Fig. 6 shows a flowchart of the main module of the invention;

Fig. 7 shows a flowchart of the self-seed module of the invention;

Fig. 8 shows a flowchart of the process-node module of the invention;

Fig. 9 shows a flowchart of the process-ping module of the invention;

Fig. 10 shows a flowchart of the process-IFIP module of the invention;

Fig. 11 shows a flowchart of the store-IP module of the invention;

Fig. 12 shows a flowchart of the store-IF module of the invention;

Fig. 13 shows a flowchart of the invalidnode module of the invention;

Fig. 14 shows a flowchart of the findnode module of the invention;

Fig. 15 shows a flowchart of the addnode module of the invention;

Fig. 16 shows a flowchart of the process-AT module of the invention; and

Fig. 17 shows a flowchart of the store-AT module of the invention.

#### DESCRIPTION OF THE PREFERRED EMBODIMENT

The following description is of the best presently contemplated mode of carrying out the present invention. This description is not to be taken in a limiting sense but is made merely for the purpose of describing the general principles of the invention. The scope of the invention should be determined by referencing the appended claims.

Fig. 1 shows a block diagram of the computer hardware that contains the discovery system of the present invention. Referring now to Fig. 1, a computer system 100 contains a processing element 102. The processing element 102 communicates to other elements within the computer system 100 over a system bus 104. A keyboard 106 is used to input information from a user of the system, and a display 108 is used to output information to the user. A network interface 112 is used to interface the system 100 to a network 118 to allow the computer system 100 to act as a node on a network. A disk 114 is used to store the software of the discovery system of the present invention, as well as to store the data base collected by the discovery system. A printer 116 can be used to provide a hard copy output of the nodes of the network discovered by the discovery system. A main memory 110 within the system 100 contains the discovery system 120 of the present invention. The discovery system 120 communicates with an operating system 122 and

network 118.

Fig. 2 shows a diagram of a network. Referring now to Fig. 2, a network 202 contains a node 206. Node 206 contains the processor 100 (Fig. 1) which contains the discovery system software of the present invention. Node 206 is attached to a first network segment 118. The network segment 118 is connected to a repeater 212 which is connected to a second network sequent 214. This second network system 214 has nodes 216 and 218 attached to it. A repeater, such as repeater 212, allows network sequents to be connected to allow a network to be extended over a longer distance. An important characteristic of a repeater is that there is no translation of data passing through it. That is, every message that is transmitted on one network segment, will pass unchanged through a repeater to the other network segment. Therefore, any messages broadcast, for example, by node 206 will be received by node 216 and node 218 after these messages pass through repeater 212.

Network segment 118 is also attached to a bridge 208 which connects it to a third network sequent 210. A bridge will only pass messages that are being transmitted from a node on one side of the bridge to a node on the other side of the bridge. It will block messages that are transmitted from a node on one side of the bridge to a node on that same side of the bridge. This characteristic reduces network traffic on various sequents of a network.

Segment 118 is also attached to a router/gateway 220 which connects is to a fourth network segment 222. Routers are devices that connect network segments which have similar characteristics. Gateways are devices which connect networks having different types of characteristics. For example, a gateway might connect a local area network to a wide area network.

Because bridges, routers, and gateways, must process the messages sent over the network, they also must contain information about which nodes are on the network. Therefore, bridges, routers, and gateways are authoritative sources of information for determining the nodes on the network. A protocol defines the format of messages that are sent across a network. One popular protocol is the Department of Defense Internetworking Protocol Suite, popularly known as TCP/IP. Because it was developed by the Department of Defense, this protocol is widely available and used extensively, particularly in a university environment. Also, this suite of protocols is very popular on the UNIX operating system and has seen wide distribution there. The internet protocol (IP) uses a single thirty-two bit address for all nodes that can be connected to the internet at any location. Physical addresses within a particular type of network, are normally different from an IP address. If a network address is very small, perhaps eight bits, it may be the same as the low order eight bits of the IP address. If

a network address is large, for example, some LANs use forty-eight bit addresses, it is impossible for these addresses to correspond directly to IP addresses. Therefore, both an IP address and a physical address exist for each node on a network. Devices such as routers, gateways, and bridges, which can send messages from one network to another must be able to translate between IP addresses and physical addresses. Therefore, these devices have translation tables which allow them to translate between these two types of addresses. By accessing these translation tables, one of the nodes on a network can obtain information about the other nodes on the network. The existence of these translation tables allow the method of the present invention to perform its function.

A network probe 224 is also attached to the network 118. A network probe 224 is a device that assists in locating defective nodes and assists in repairing those nodes. Since it is a testing device, it may or may not be attached to a network at any given time. When a probe is attached to a network, the discovery system of the present invention can query the probe and use information obtained from the probe to assist in discovering other nodes on the network.

Figs. 3 through 5 show a hierarchy diagram of the modules of the software of the present invention. Referring now to Figs. 3 through 5, discovery module 302 is the main module of the system. Discovery calls self-seed block 304 to start the process of building a database about the network, and it calls process-node block 306 to process information about each node that it obtained from self-seed. Process-node block 306 calls process-ping block 308 to query a node on the network to determine if that node is active. Process-node block 306 also calls process-IFIP block 310 for each IP address that it obtains. Process-IFIP block 310 calls store-IP block 402 for each IP address, and store-IP block 402 calls invalidnode block 406, findnode block 408, and addnode block 410, for each IP address. For each IF entry (physical address) received, process-IFIP block 310 calls store-IF block 404. For each address translation table entry, process-node block 306 calls process-AT block 312 which in turn calls store-AT block 502. Store-AT block 502 calls invalidnode at block 504, findnode block 506, and addnode block 508.

Fig. 6 shows a flowchart of the discovery module block 302 (Fig. 3). Referring now to Fig. 6, after entry block 602 gets any options that the user wishes to enter. Block 604 then initializes the database used to permanently store the nodes, and loads node list from existing entries in the database. If a database for the network does not exist, the discovery system has the ability to create that database. If a database of the network already exists, the discovery system will use the node information which is already available in that database to query other nodes within the system.

Block 606 then initializes domains. A domain

defines the limit beyond which the user of the discovery system does not wish to find nodes. That is, the domain limits the range of the discovery process. This limitation is necessary on large networks, to keep the amount of processing to reasonable level. Furthermore, a user usually is only interested in the nodes on a particular network segment, or the network segment connected by repeaters and possibly bridges.

Block 608 then calls Fig. 7 to self-seed the system. If no entries were available in the database, the discovery system can self-seed by sending a broadcast message and determine who responds to that message. After returning from self-seed, block 610 points to the first node list entry. As discussed earlier, the node list will contain a list of the nodes already known to the system. This list can be input from the database, or the list can be started from self-seed module. After pointing to the first entry, block 612 determines if there are more entries to process. If there are no more entries to process, block 612 transfers to block 614 which will wait a predetermined period of time before reprocessing the entire node list. Typically, block 614 will wait for approximately thirty seconds. By reprocessing the node list periodically, additional nodes can be discovered. This is because a node may be inactive on the system at any given time and might not be discovered by a single pass through the network. By waiting and reprocessing the node list, nodes that were inactive may now be active and additional information can be obtained.

If more entries in the node list exist, block 612 transfers to block 616 to process one of the nodes. After processing that node, block 616 transfers to block 618 which points to the next node list entry and returns to block 612 to process the next node.

Fig. 7 shows a flowchart for the self-seed block 304 (Fig. 3) which obtains initial information about nodes on the network. Referring now to Fig. 7, after entry, block 702 sends an SP broadcast request to all nodes on the network. SNMP stands for Simple Network Management Protocol, and is a part of the TCP/IP network software. After sending the broadcast request, block 702 transfers to block 704 which receives SNMP messages from the nodes. If more SNMP messages are available, block 704 transfers to block 706 which adds a node to the node list for each message received. In this manner, all nodes that are currently active on the network can be queried to obtain initial information about the node. After all SNMP messages have been received, block 704 returns to the caller.

Another way of self-seeding is to query the address translation table for the node that is executing the discovery system. This table will contain the addresses of other nodes on the network, and these addresses are then used to start the discovery process.

(Fig. 3). The process-node module of Fig. 8 is called from the discovery module of Fig. 6 once for each entry in the node list. Therefore, when Fig. 8 is called, the address of a single node is passed to it. Referring now to Fig. 8, after entry, block 802 determines whether the node is within a domain. As discussed earlier, the domain defines the limits beyond which the discovery program does not wish to discover new nodes. If the node is within the domain, block 802 transfers to block 804 which calls the process-ping module of Fig. 9 to determine whether the node is active. After returning from Fig. 9, block 804 transfers to block 806 to determine whether the state of the node has changed since the last information was obtained. That is, when the process-ping module queries the node, it determines the state of the node at the present time. This state is compared, in block 806, with the state of the node as it was known previously in the database. If that state has changed, block 806 transfers to block 808 to store the new state in the database. Control then returns to block 810 which calls process-IFIP to retrieve the IF and IP tables from the node. After returning from Fig. 10, block 810 transfers to block 812 which determines whether the node responded to an SNMP request. If the node did respond to the SNMP request, block 812 transfers to block 814 which determines whether the node is currently in the database. If the node is not in the database, block 814 transfers to block 816 to add the node to the database. Control then continues at block 818 which calls Fig. 16 to retrieve the address translation table from the node. Control then returns to the caller.

Fig. 9 shows a flowchart of the process-ping module block 308 (Fig. 3). This module is called to determine whether a node is active on the network. Referring now to Fig. 9, after entry block 902 determines whether the ping interval has elapsed. The ping interval is used to prevent a node from being queried too often. If the ping interval has not elapsed, block 902 returns to the caller. If the ping interval has elapsed, block 902 transfers to block 904 which sends an ICMP-echo message to the node. The ICMP-echo protocol is defined as a part of TCP/IP and is used to cause the node to return an acknowledgement to a message. Block 904 then transfers to block 906 which determines whether a response has been received from the other node. If a response has not been received within a predetermined amount of time, typically block 906 transfers to block 910 which sets a flag to indicate that the node failed to respond. If the node does respond, block 906 transfers to block 908 which sets a flag to indicate that the node did respond and then block 912 sets a new ping interval which will prevent the node from being pinged for the period of the interval. The ping interval is typically five minutes. Block 912 then returns to the caller.

Fig. 10 shows a flowchart of the process-IFIP

available in a node to define the translation of physical addresses to IP addresses. The information is available as two different tables, with an index contained in the IF table to cross-reference to the IP table within the node. By obtaining these two tables, the discovery system can determine what the other interfaces to which a node is connected, and therefore determine other networks to which the node is connected. Referring now to Fig. 10, after entry, block 1002 determines whether the IFIP interval has elapsed. The IFIP interval is similar to the ping interval described with respect to Fig. 9, and is used to keep a node from being queried too often. If the IFIP interval has not elapsed, block 1002 returns to the caller. If the IFIP has elapsed, block 1002 transfers to block 1004 which sends an SNMP message to request the node to send its next IP table entry to the discovery node. When an entry is received, block 1006 calls store-IP module of Fig. 11 to store the node within the node list. Block 1007 then transfers back to block 1004 if more IP entries are available. After all the entries are all stored in the node list, block 1007 transfers to block 1008 which sets a new IFIP interval of typically greater than 10 hours. Block 1010 then sends an SNMP message to request that the node send its next IF table entry to the discovery node. When an IF table entry is received, block 1012 calls the store-IF module of Fig. 12. Block 1014 then transfers back to block 101 if more entries are available. After receiving and storing all the IF table entries, block 1014 returns to the caller. Each IF table entry contains an index into the IP table. By using this index, physical addresses in the IF table can be matched with the IP address.

Fig. 11 shows a flowchart of the store-IP process block 402 (Fig. 4). Referring now to Fig. 11, after entry block 1102 calls Fig. 14 to find the node in the node list. The node will be found if the discovery system has already encountered this node in its process. Block 1304 then determines whether the node exists, and if the node does not exist, block 1104 transfers to block 1106 which calls Fig. 13 to determine whether the node is valid. Block 1108 then determines if the node is valid and if it is valid, block 1108 transfers to block 1110 to add the node to the node list. After adding the node, or if the node already existed, control goes to block 1112 which updates the state information about the node. After updating the node state information or if the node was not valid, Fig. 11 returns to the caller.

Fig. 12 is a flowchart of the store-IF process of block 404 (Fig. 4). This module is called for each table entry in the IF table received from a node. Referring now Fig. 12, after entry, block 1202 finds the IP index within the IF record. As described earlier, each IF table entry will have a corresponding IP table entry, and the IP entry is referenced by an index value contained in the IF entry. Block 1204 then determines whether a matching IP record exists. If a matching IP record does exist, block 1204 transfers to block 1206

which moves the physical address from the IP record to the node record in the node list. Block 1208 then updates any state information in the node record. After updating the state information, or if there were no matching IP record, Fig. 12 returns to its caller.

Fig. 13 shows a flowchart of the invalidnode module block 406 (Fig. 4). Referring now Fig. 13, after entry, block 1302 determines whether the address of the node is simply the loopback address of another node. Each node has a loopback address associated with it for use in testing the node. Because the loopback address refers to the same node, no additional information can be obtained from that node and the loopback address is never stored as a node address. If the IP address is not equal to the loopback address, block 1302 transfers to block 1304 to determine whether the node is within the domain. As described earlier, the domain is used to determine the limits beyond which the discovery system will not attempt to discover new nodes. If the node is within the domain, block 1304 transfers to block 1306 which returns an indication that the node is valid. If the node is not within the domain or if the IP address equals the loopback address, control transfers to block 1308 which returns an error indication indicating that node is not valid. Control then returns to the caller.

Fig. 14 is a flowchart of the findnode module block 408 (Fig. 4). The module is used to find a node within the node list. Referring now Fig. 14, after entry, block 1402 gets the node list entry. Block 1404 then determines whether the IP address matches the entry in the list. If a match does occur, block 1404 transfers to block 1408 which returns an indication that the node is in the node list. If the IP address does not match, block 1404 transfers to block 1406 which gets the next node list entry and block 1410 then determines whether the end of table has been reached. If the end of the list has not been reached, block 1410 transfers back to block 1404 to check the entry just found. If the end of the list has occurred, block 1410 transfers to block 1412 which returns an error indication indicating that the node is not in the node list.

Fig. 15 shows a flowchart of the process of adding a node to the node list. Referring now to Fig. 15, after entry, block 1502 performs a hash operation on the IP address to create a pointer into the node list. Block 1504 then allocates memory for a node record, and block 1506 stores the data available for the node into the node record at the location pointed to by the hashed IP address. Block 1506 then returns to the caller.

Fig. 16 shows a flowchart of the process-AT module of block 312 (Fig. 3). This module is called by the process-node module for each entry in the node list. Referring now to Fig. 16, after entry, block 1602 determines whether the AT interval has expired. The AT interval is used to prevent a node from being polled too frequently. If the AT interval has not expired, block



1602 simply returns to the caller. If the AT interval has expired, block 1602 transfers to block 1604 which sends an SNMP message to request that the node send its next address translation table entry to the discovery node. When an entry is received, block 1606 is called to store the table entry. Block 1607 then transfers back to block 1604 if more table entries are available. After storing all the table entries, block 1607 transfers to block 1608 which updates the node's state information in the node list. Block 1610 then sets a new AT interval, typically fifteen seconds, and returns to the caller.

Fig. 17 shows a flowchart of the store-AT module of block 502 (Fig. 5). Referring now to Fig. 17, after entry, block 1702 calls the findnode module Fig. 14 to determine whether the node is already in the node list. If the node is in the node list, block 1704 transfers to block 1712. If the node is not in the node list, block 1704 transfers to block 1706 which calls Fig. 13 to determine whether the node is a valid node. If the node is not valid, block 1708 returns to the caller. If the node is valid, block 1708 transfers to block 1710 which calls Fig. 15 to add the node to the node list. After adding the node to the node list, or if the node already existed, control transfers to block 1712 which updates the state information about the node in the node list before returning to the caller.

In addition to querying nodes on the network, the discovery system can also query any network probes that may be attached to the network. Information about other nodes on the network can be obtained from these probes, and the discovery system can use this information to assist in discovering other nodes on the network.

Having thus described a presently preferred embodiment of the present invention, it will now be appreciated that the objects of the invention have been fully achieved, and it will be understood by those skilled in the art that many changes in construction and circuitry and widely differing embodiments and applications of the invention will suggest themselves without departing from the spirit and scope of the present invention. The disclosures and the description herein are intended to be illustrative and are not in any sense limiting of the invention, more preferably defined in scope by the following claims.

### Claims

1. A computer network node discovery process (120) for determining nodes (206, 216, 218) connected to a computer network (118), said process (120) comprising the steps of:
  - (a) obtaining (306), from one node of a set of known nodes on said computer network (118), a list of addresses of one or more other nodes
  - (b) repeating step (a) for each of said other nodes obtained; and
  - (c) storing said list of node addresses in a file (808); whereby said list of node addresses may be displayed to a user of said computer network.
2. The process of claim 1 further comprising the step of:
  - (d) repeating steps (a) through (c) at regular time intervals.
3. The process of claim 2 further comprising the step of:
  - (a1) obtaining from each bridge unit (208) connected to said network (118) a list of addresses of all nodes accessible by said bridge unit (208).
4. The process of claim 3 further comprising the step of:
  - (a2) obtaining from each router unit (220) connected to said network (118) a list of addresses of all nodes accessible by said router unit (220).
5. The process of claim 4 further comprising the step of:
  - (a3) obtaining from each gateway unit (220) connected to said network (118) a list of addresses of all nodes accessible by said gateway unit (220).
6. The process of claim 5 further comprising the step of:
  - (a4) obtaining from any network probe device (224) connected to said network (118) a list of addresses of all nodes known to said network probe device (224).
7. A computer network node discovery process (120) for determining nodes connected to a TCP/IP computer network (118), said process comprising the steps of:
  - (a) obtaining (306), from one node of a set of known nodes on said computer network, an address translation table containing a list of addresses of other nodes with which said one node communicates;
  - (b) repeating step (a) for each of said other nodes in said address translation table;
  - (c) storing said list of nodes in a file (808); and
  - (d) repeating steps (a) through (c) at regular time intervals.
8. The process of claim 7 further comprising the steps of:

ected to said network (118) an address translation table containing a list of addresses of nodes accessible from said bridge unit (208);

(a2) obtaining from each router unit (220) connected to said network (118) an address translation table containing a list of addresses of nodes accessible from said router unit (220);

(a3) obtaining from each gateway unit (220) connected to said network (118) an address translation table containing a list of addresses of nodes accessible from said gateway unit (220);

(a4) obtaining from any network probe devices (224) attached to said network (118) a list of addresses of all nodes known to said network probe (224); and

(a5) obtaining from each node in said network (118) an interface table and an internet protocol table which defines other networks and nodes to which said node is connected.

(224) attached to said network (118) a list of addresses of all nodes known to the network probe (224).

- 9. A computer network node discovery process (120) for determining nodes connected to a computer network (118), said process comprising the steps of:
  - (a) sending a general response message (307) to all nodes on said network;
  - (b) creating a node list (410) containing the address of each node responding to said general response message;
  - (c) obtaining (306), from each node in said node list, a second list of addresses of other nodes with which said node communicates;
  - (d) adding each node (410) in said second list to said node list;
  - (e) repeating steps (c) through (d) for each of said nodes in said second list;
  - (f) storing said node list in a file (808); and
  - (g) repeating steps (a) through (f) at regular time intervals.
  
- 10. The process of claim 9 further comprising the steps of:
  - (c1) obtaining from each bridge unit (208) connected to said network (118) a list of addresses of all nodes accessible by said bridge unit (208);
  - (c2) obtaining from each router unit (220) connected to said network (118) a list of addresses of all nodes accessible by said router unit (220);
  - (c3) obtaining from each gateway unit (220) connected to said network (118) a list of addresses of all nodes accessible by said gateway unit (220); and
  - (c4) obtaining from any network probe devices

5

10

15

20

25

30

35

40

45

50

55

9

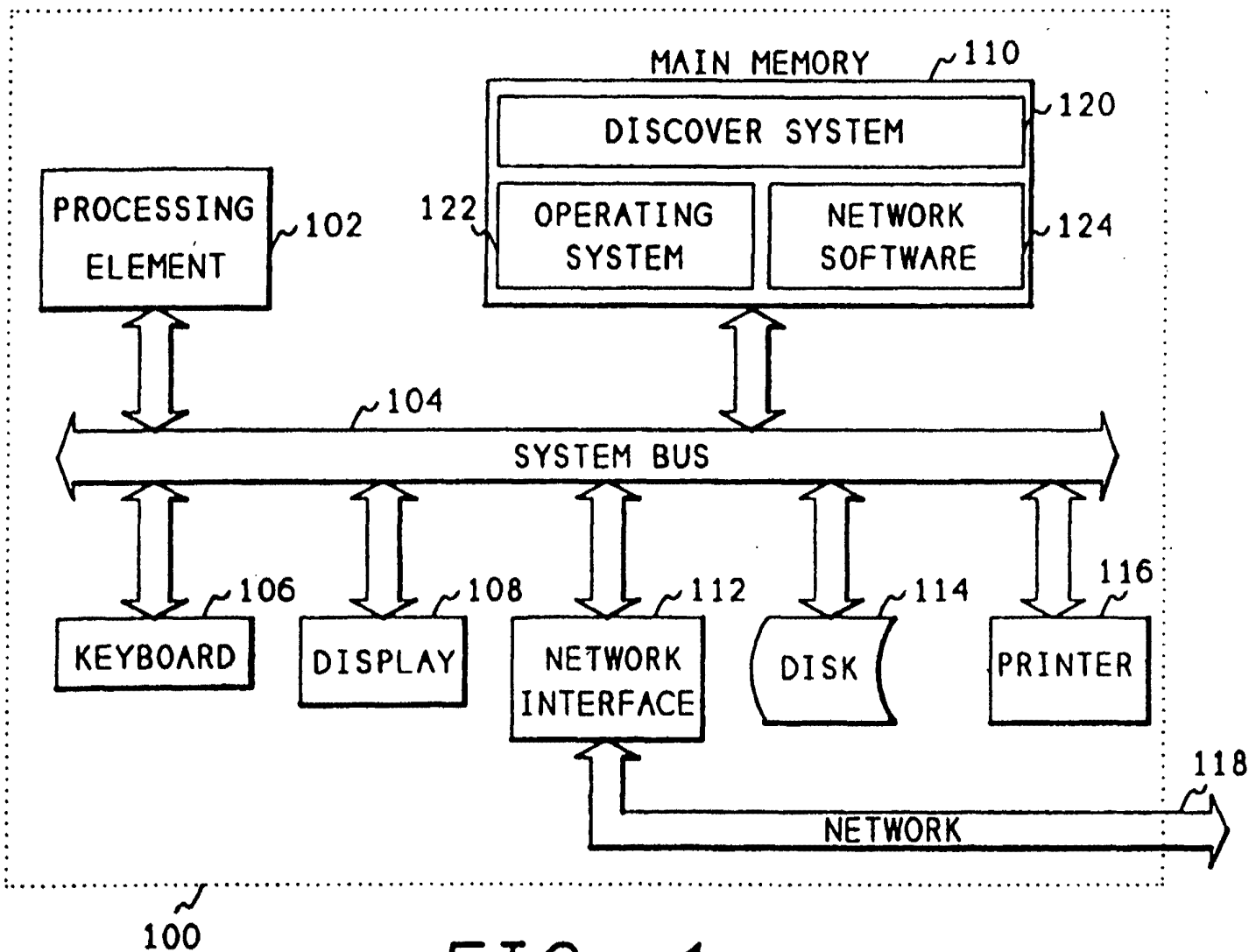


FIG. 1

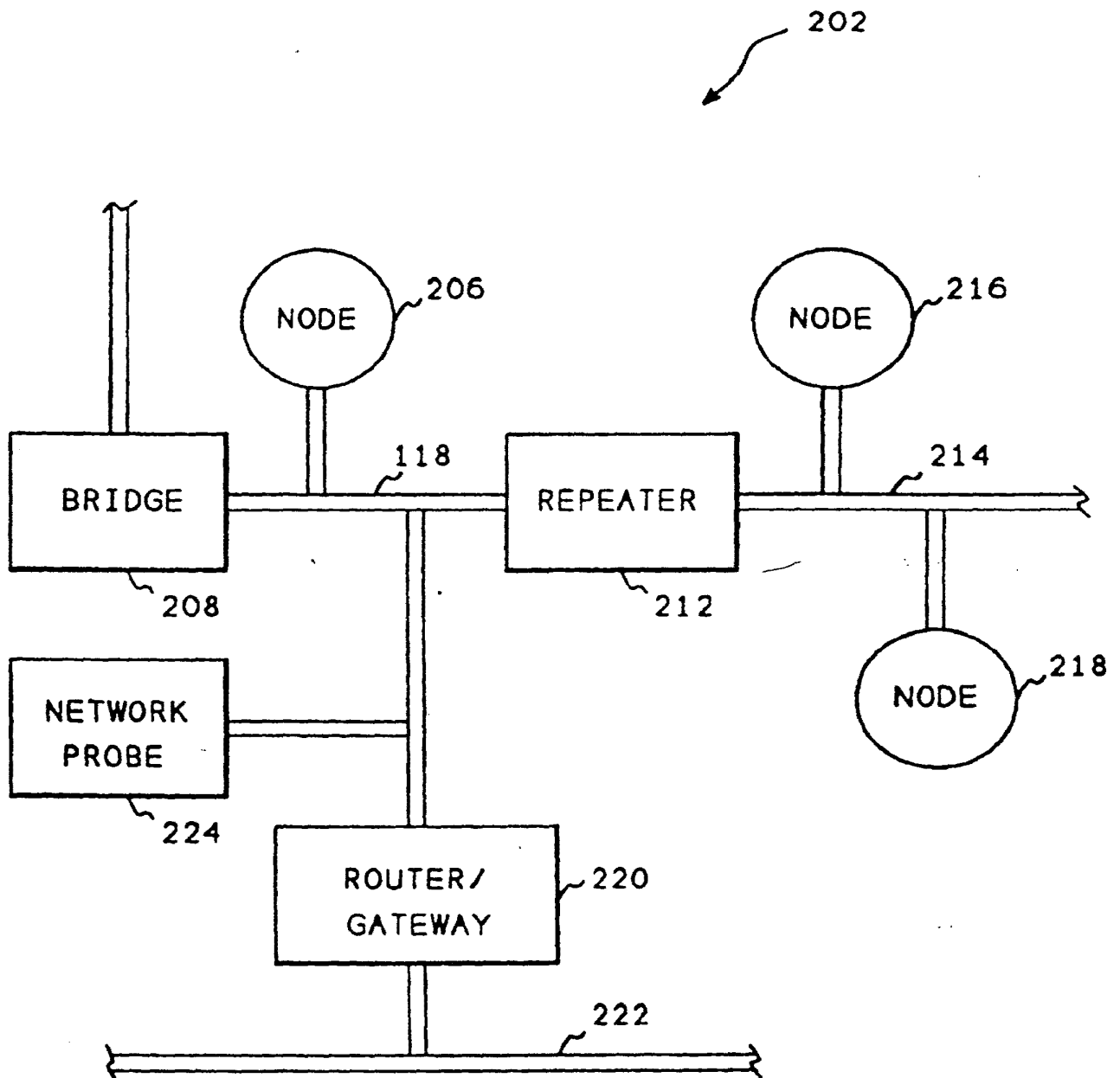


FIG. 2

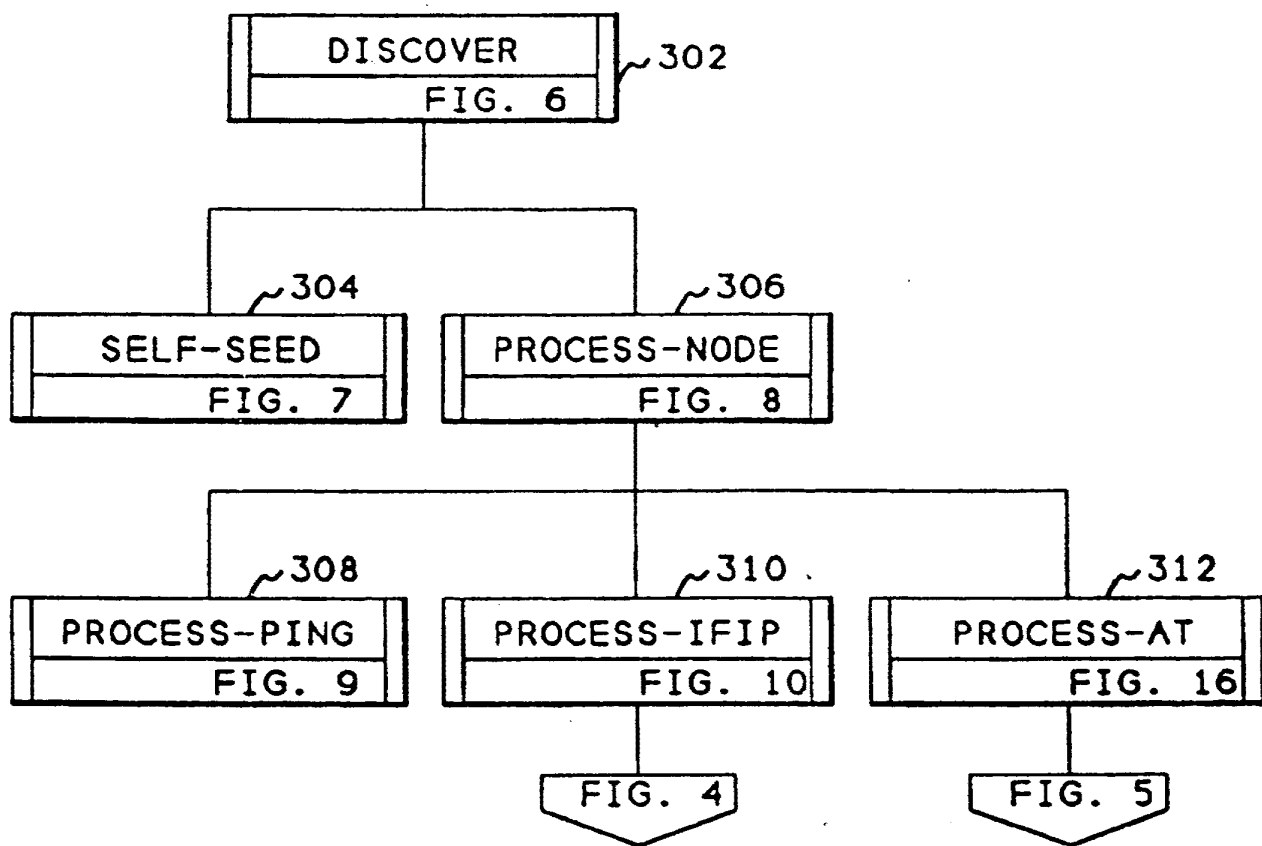


FIG. 3

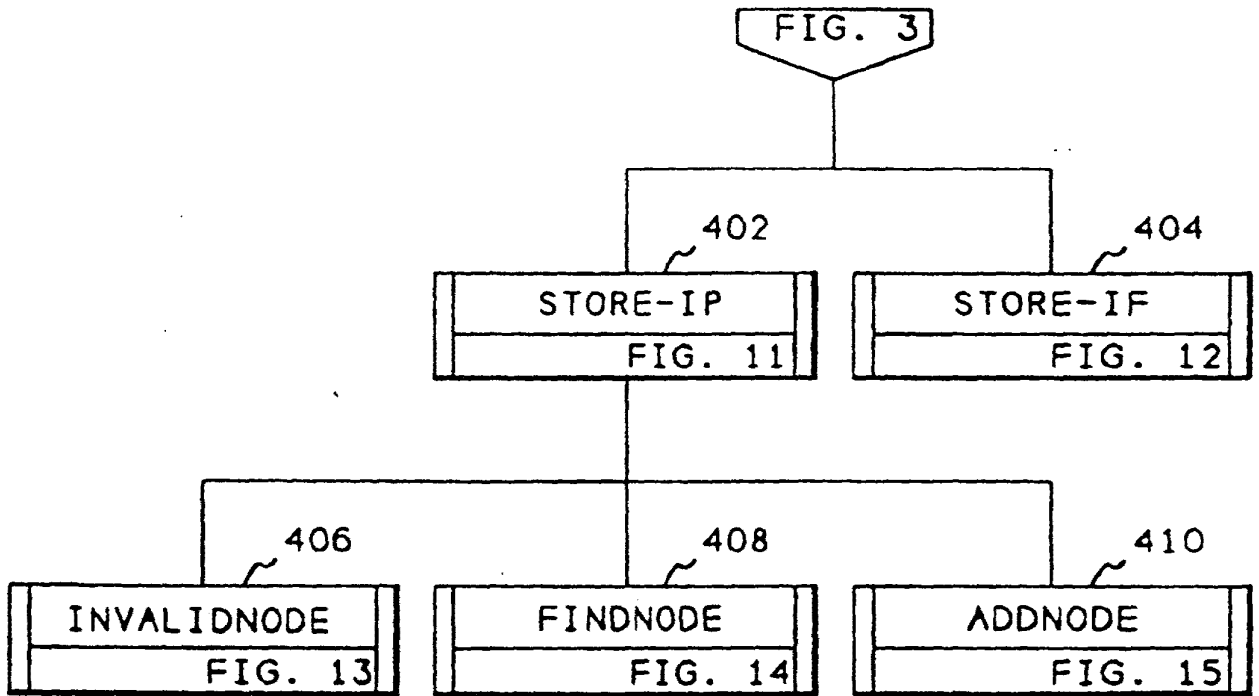
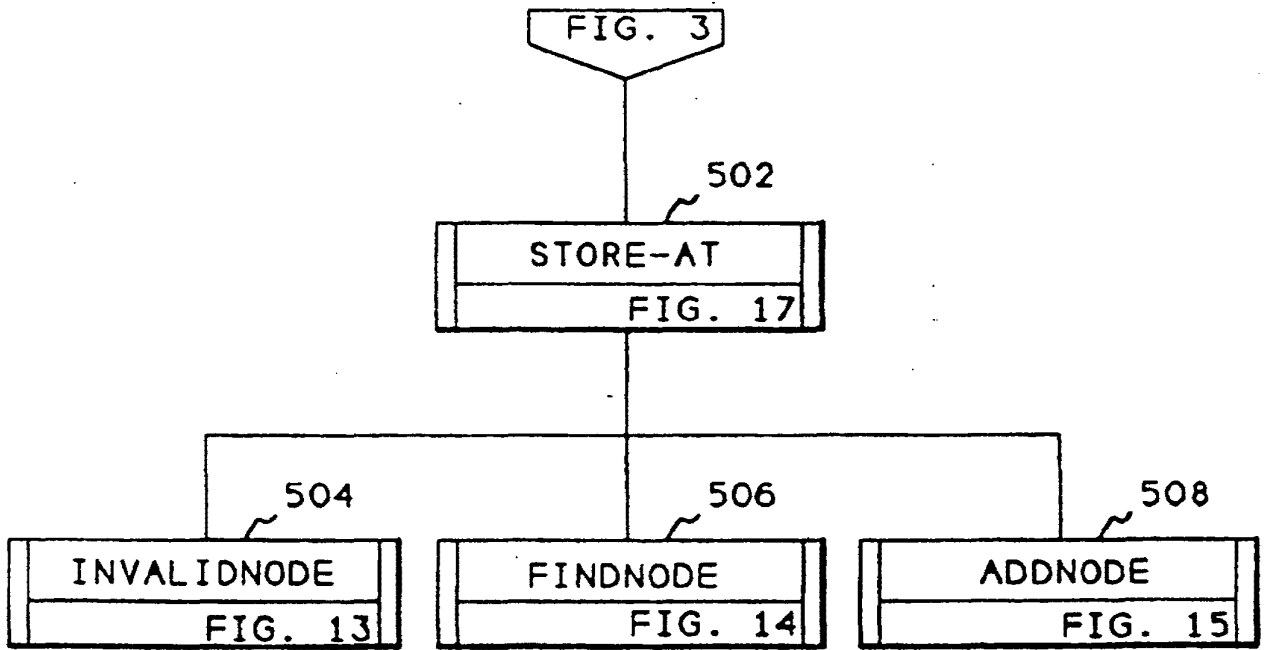


FIG. 4



*FIG. 5*

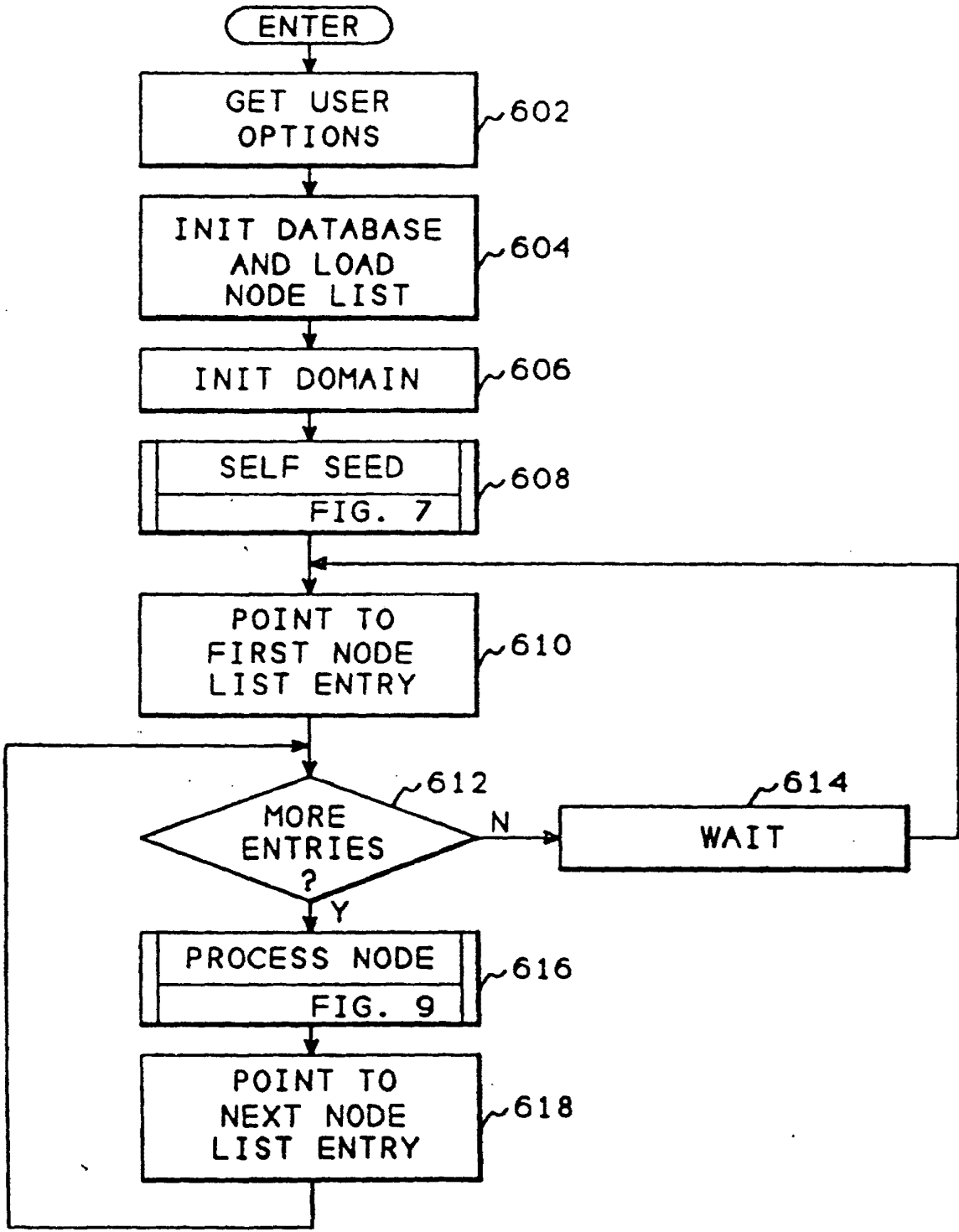


FIG. 6



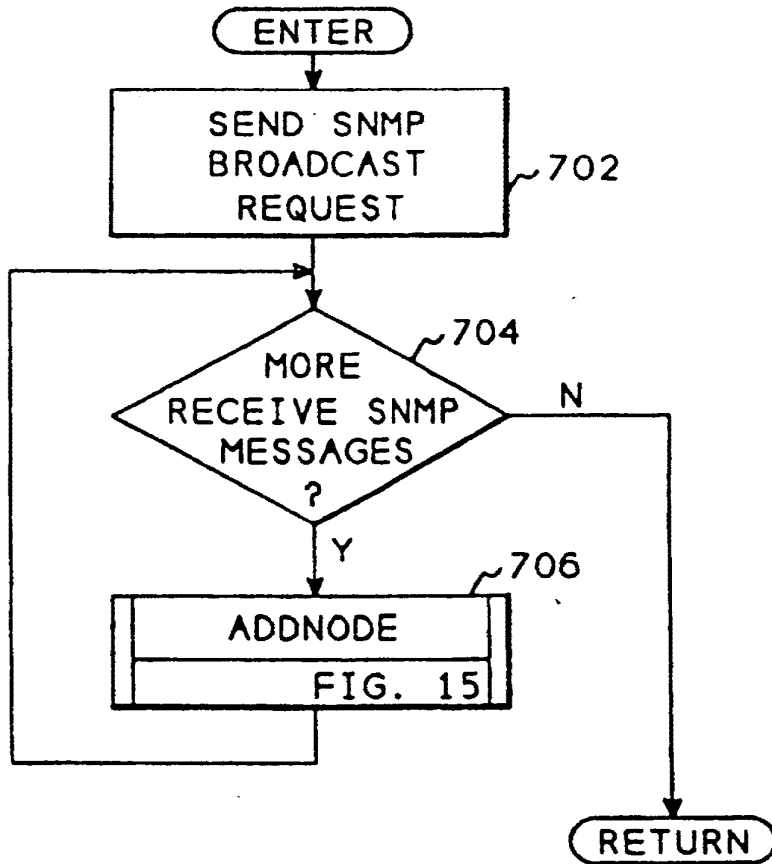


FIG. 7

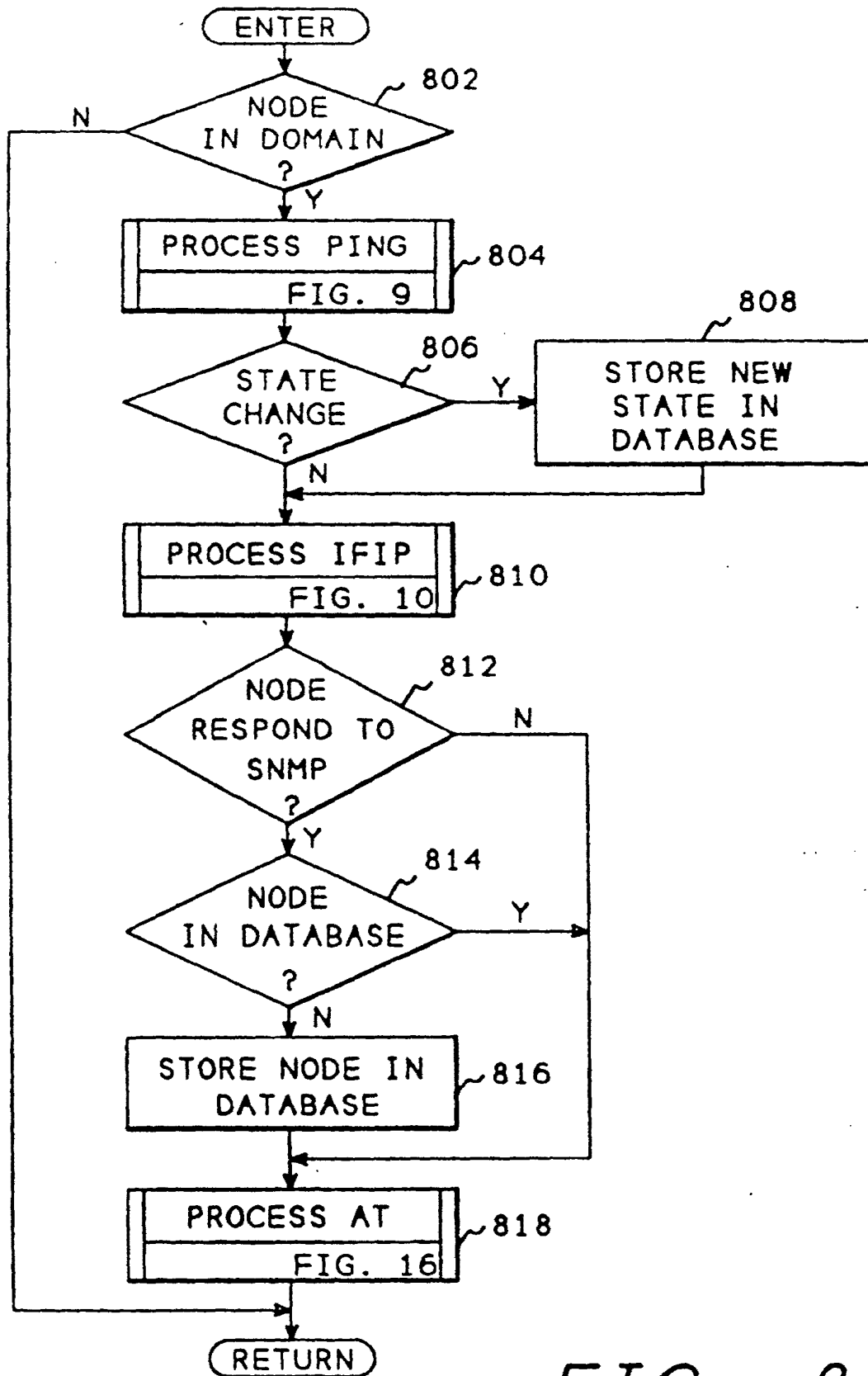


FIG. 8

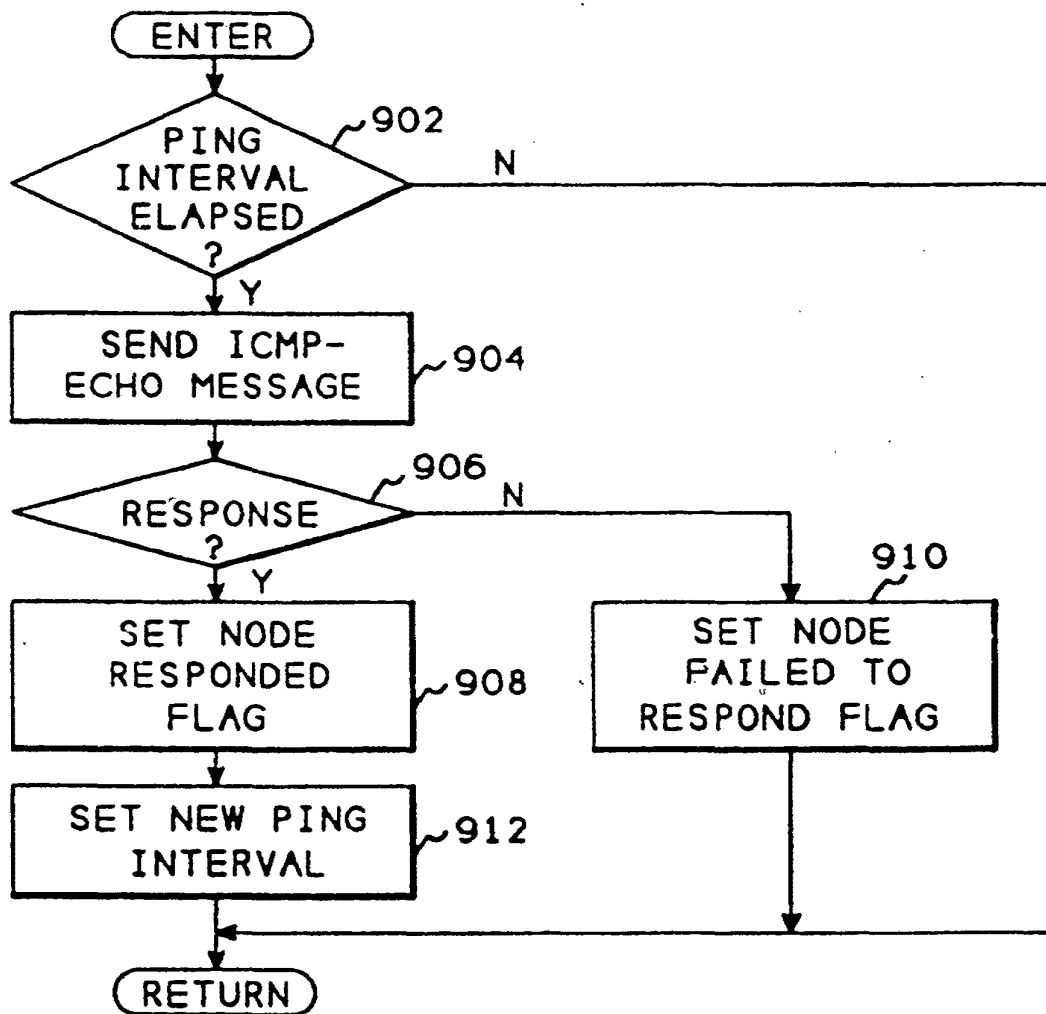


FIG. 9

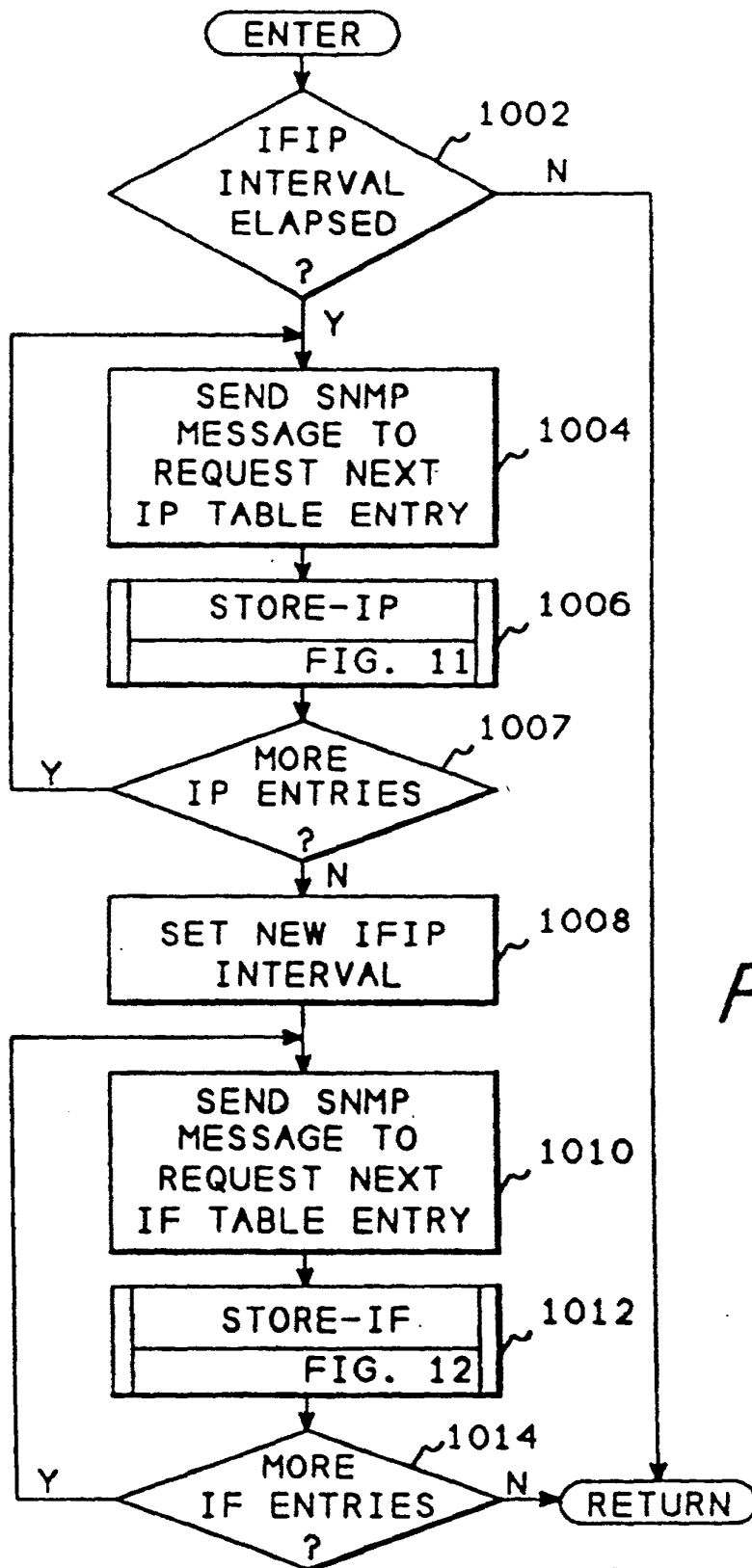


FIG. 10

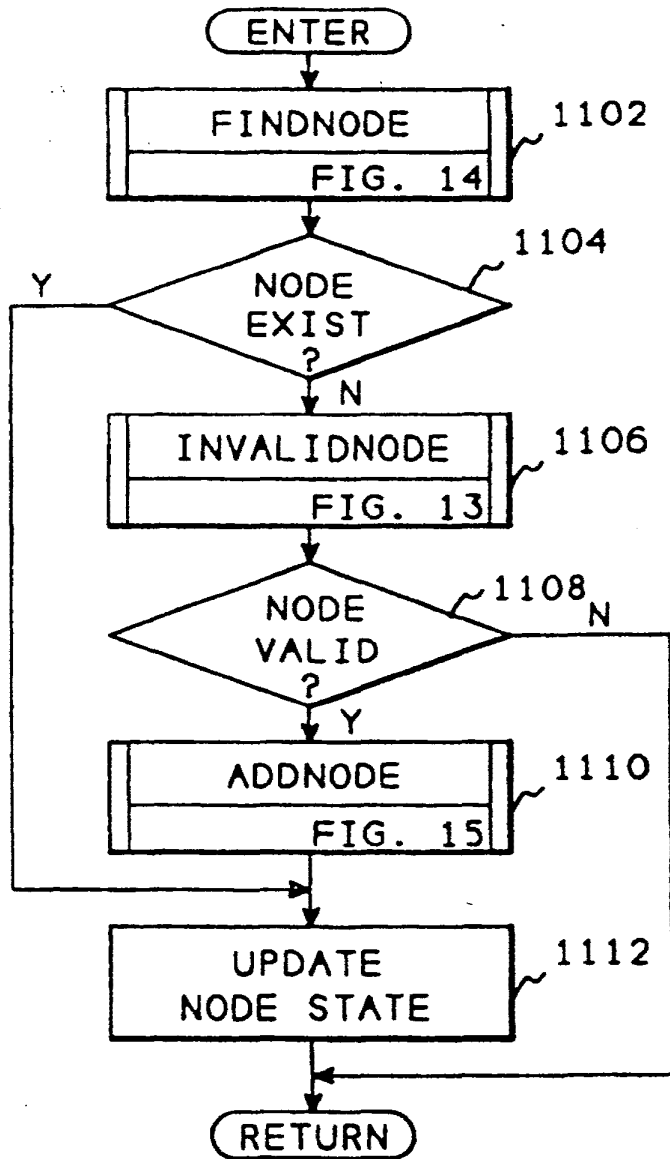


FIG. 11

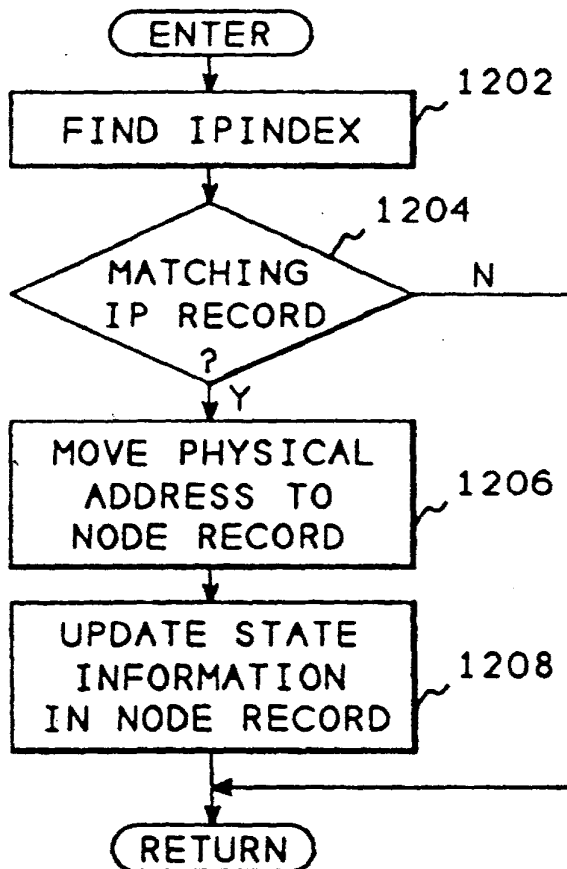


FIG. 12

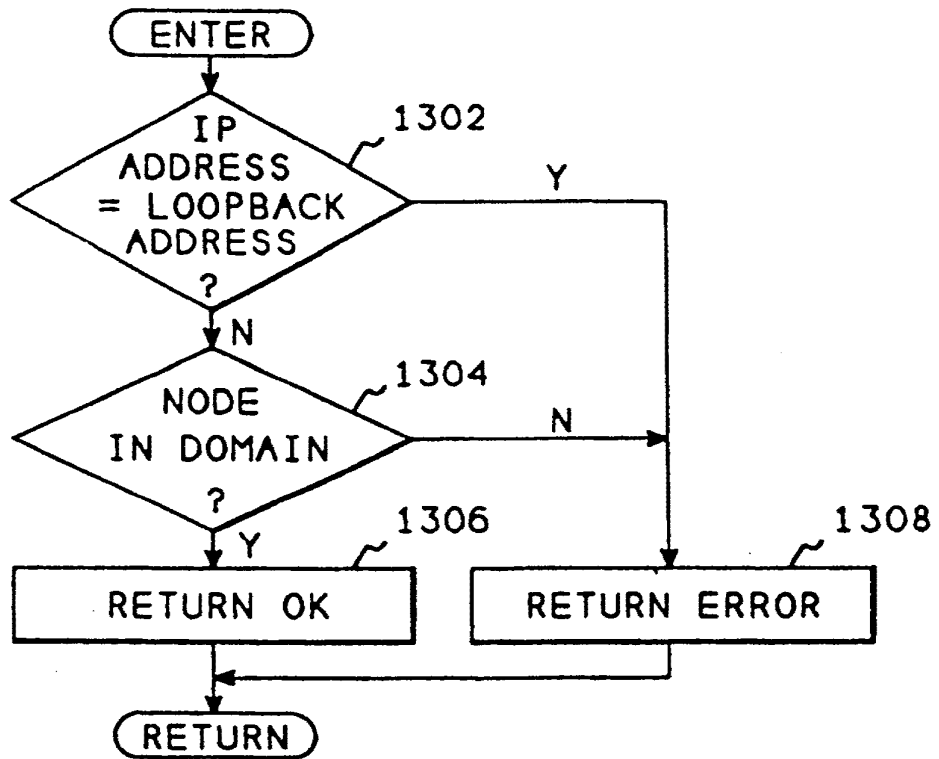


FIG. 13

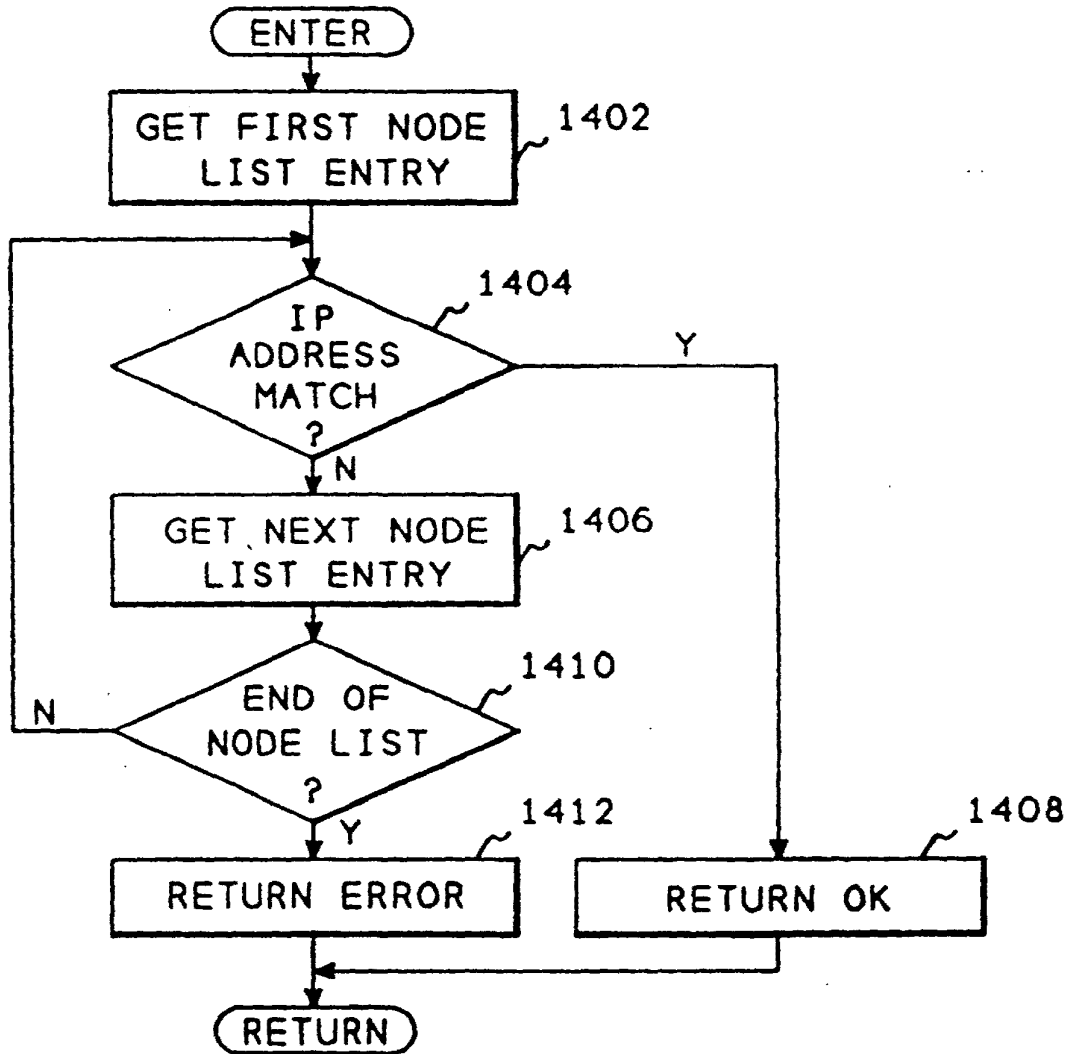
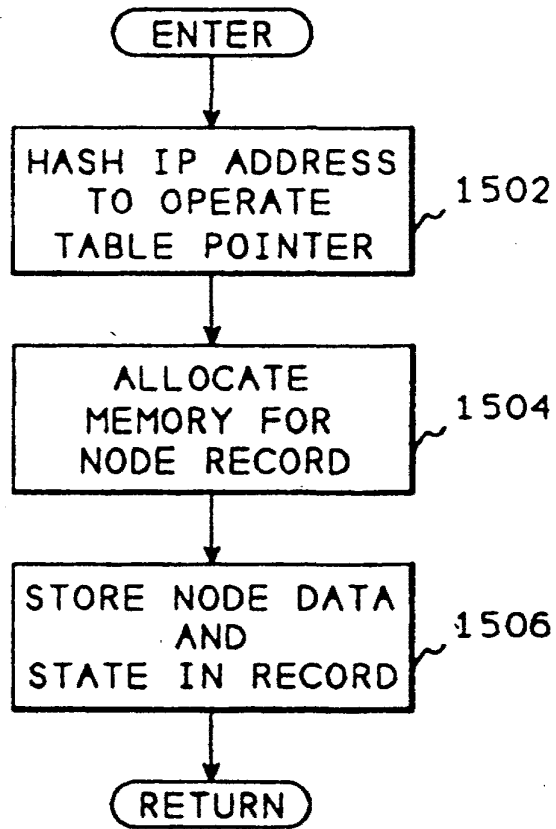


FIG. 14





*FIG. 15*

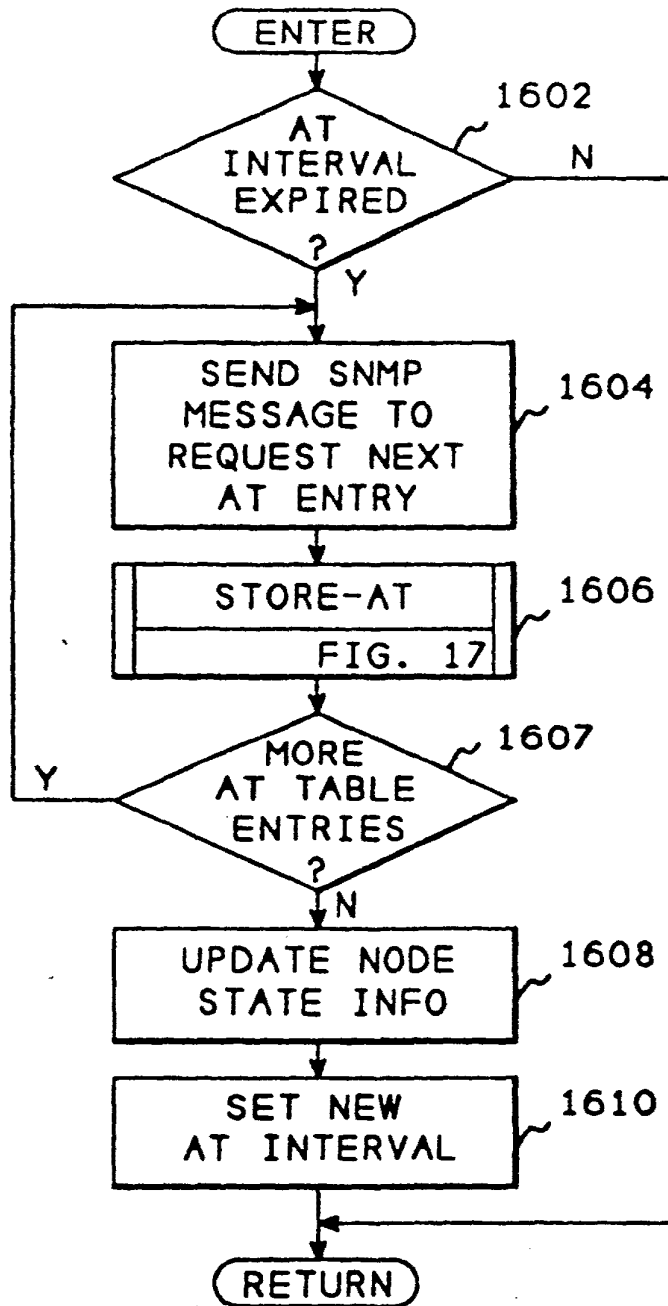


FIG. 16

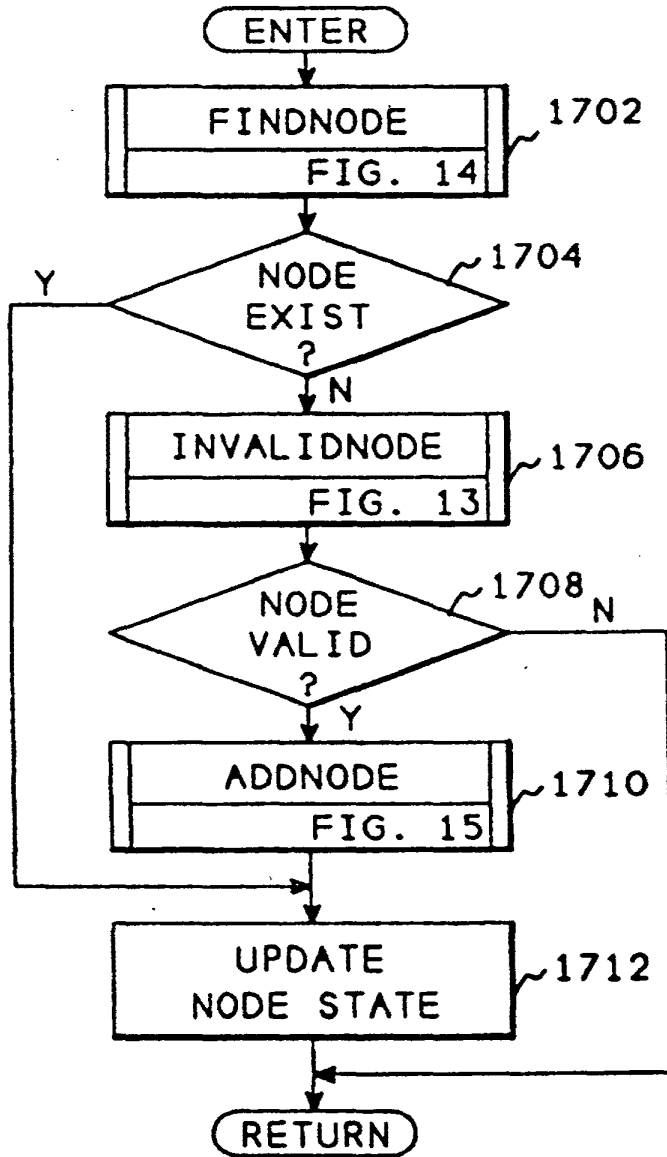


FIG. 17

#13



**EUROPEAN PATENT APPLICATION**

(21) Application number : **93300919.3**  
 (22) Date of filing : **09.02.93**

(51) Int. Cl.<sup>5</sup> : **H04Q 7/00, H04L 12/56**

(30) Priority : **10.02.92 JP 23506/92**  
               **16.09.92 JP 246855/92**  
               **10.11.92 JP 299531/92**  
 (43) Date of publication of application :  
       **18.08.93 Bulletin 93/33**  
 (84) Designated Contracting States :  
       **DE FR GB**  
 (71) Applicant : **MATSUSHITA ELECTRIC**  
                   **INDUSTRIAL CO., LTD.**  
                   **1006, Kadoma**  
                   **Kadoma-shi, Osaka-fu 571 (JP)**

(72) Inventor : **Wada, Hiromi**  
               **15-10, Higashigaoka, Uzumasa**  
               **Neyagawa-shi, Osaka 572 (JP)**  
               Inventor : **Yozawa, Takashi**  
               **5-16-19, Shinke, Aoo**  
               **Mino-shi, Osaka 562 (JP)**  
               Inventor : **Ohnishi, Tatsuya**  
               **281-5, Kawahara, Aza, Sasabe**  
               **Kawanishi-shi, Hyogo 666-01 (JP)**  
 (74) Representative : **Cummings, Sean Patrick et al**  
                           **David Keltie Associates Audrey House Ely**  
                           **Place**  
                           **London EC1N 6SN (GB)**

(54) **Migration communication control device.**

(57) Disclosed is a migration communication control device constructed to control a continuous communication between a mobile node and a node unaffected the mobile node's migration. The migration communication control device comprises a first migration control unit, a second migration control unit on the mobile node, and a third migration control unit on the partner node. The first migration control unit comprises a packet transfer unit and an address post unit. The packet transfer unit receives a packet which was destined for an outdated address of the mobile node, generates a conversion packet which holds an updated address instead of the outdated address, and then transmits the conversion packet, while an address post unit transmits an address post message which indicates the updated address to the third migration control unit. The second migration control unit comprises a migration post unit and a packet resumption unit. The migration post unit transmits to the first migration control unit a migration post message which indicates the updated address when the mobile node migrates to another network while a packet resumption unit receives the conversion packet from both the first migration control unit and the third migration control unit and resumes an original packet from the conversion packet. The third migration control unit comprises a packet conversion unit which converts a destination address of a packet into the updated address, then transmits it to the mobile node.

EP 0 556 012 A2

BACKGROUND OF THE INVENTION

(1) Field of the Invention

The present invention relates to a migration communication control device that controls a communication between a mobile node and a corresponding node to enable them to communicate continuously when the former migrates by managing addresses assigned to the former each time it migrates across networks.

(2) Description of the Related Art

Recent progress in the field of electronic technology makes it possible to assemble smaller and lighter portable computers. These portable computers referred to as mobile nodes are designed so that they can migrate across networks: they are unplugged from a network and plugged in another and communicate with a stationary node. Thus, each of them is assigned a specific address to prove its identity. The address, in general, includes location information as to which network the mobile nodes are currently plugged in, and for this reason, a new address is assigned each time they migrate.

For example, the address composed of a network address unit for specifying a network in which the mobile node is currently plugged in and a node address unit for proving the mobile node's identity in the network, or the address used in a conventional network architecture such as Internet Protocol(details of which are in Internet Protocol, RFC791, Jon Postel, Sep., 1981), they must be changed every time the mobile nodes migrate.

However, once the mobile node migrates to another network, a communication with the stationary node will be terminated. This is because a packet is transmitted to its old address only to be wasted.

Thus, to enable the mobile node and stationary node to communicate continuously when the former migrates, it is necessary to control the communication by managing the steadily changing address.

To date, two address managing methods have been proposed: one by Sony Computer Science Laboratory Inc. and one by the Department of Computer Science at Columbia University.

Sony Computer Science Laboratory Inc. proposed a method using VIP(Virtual Internet Protocol), details of which are on "VIP : Lower Layer Internet Protocol", Fumio Teraoka, Yasuhiko Yokote, Mario Tokoro, Proceed of Data Processing Convention : Multimedia Communication and Distributed Processing.

In this method, each mobile node is assigned a VIP(Virtual Internet Protocol) address and a PIP(Physical Internet Protocol) address. The former is an unchanged address used in a communication application for packet transmission and reception;

and the latter is an address changed for every migration to specify an update physical location of the mobile node. Data related to both addresses are held in a cache of a gateway. Under these conditions, the stationary node transmits a packet to the mobile node to the VIP address thereof, and the packet is converted into another packet addressed to the PIP address when it passes the gateway, thence transmitted to the mobile node via the gateways placed in a route onwards. These gateways collect data related to a correlation between the VIP and PIP addresses from the header of the packet upon the receipt thereof, thus updates data in the cache, and hence are able to convert other packets addressed to the VIP addresses into the packets addressed to the PIP addresses based on the correlation entered in the cache.

In this method, in short, the use of the address constituting with the VIP and PIP addresses enables the mobile node and the stationary node to communicate continuously when the former migrates.

The Department of Computer Science at Columbia University proposed a method using an Internet Protocol address of which network address unit does not specify the network which the mobile node is currently plugged in but declares itself to be the mobile node, hence a certain value is given as the network address unit to all the mobile nodes. As well, the method uses an MSS(Mobile Support Station) installed at each network to manage the IP addresses and control a packet route to the mobile node. The MSS is designed so that it collects data related to the update physical location of the mobile nodes by referring other MSSs.

Given these conditions, when the stationary node transmits a packet to the mobile node when it migrates, it first transmits the packet to a first MSS installed in its network; thence the first MSS transfers the packet to a second MSS installed in a network which the mobile node is currently plugged in; and finally the second MSS transfers the packet to the mobile node.

In this method, in short, the use of the MSS enables the mobile node and the stationary node to continue the communication when the former migrates.

In the first method, however, all the nodes must be constructed so that they understand both the VIP and PIP addresses, causing them to extend a scale functionally, otherwise making it impossible to apply this method to apparatuses employed in existing networks. In addition, the communication via the gateways reduces communication efficiency compared with direct packet transmission, because the gateways check whether they have received the packet addressed to the VIP address or PIP address each time they receive it, as well as whether or not to collect the data therefrom to update those in the cache.

In the second method, each network must have

the MSS, and the communication via the MSSs makes it impossible to transmit the packet directly, thereby reducing the communication efficiency.

### SUMMARY OF THE INVENTION

The present invention therefore has an object to provide a migration communication control device that is available to any apparatus employed in existing networks. Also the present invention has another object to provide a migration communication control device that enables the mobile node and stationary node to communicate continuously when the former migrates by transmitting and receiving the packet directly besides transferring the packet as has been done when the mobile node migrates across the networks.

The above objects are fulfilled by a migration communication control device constructed to control a communication between a mobile node and a partner node, the mobile node migrating across networks and obtaining an address assigned on each network while the partner node being a communication partner of the mobile node, comprising a first migration control unit, a second migration control unit, a third migration control unit, the second migration control unit being placed on the mobile node and the third migration control unit being placed on the partner node, wherein the first migration control unit comprises a packet transfer unit for receiving a packet which was destined for an outdated address of the mobile node, the outdated address assigned when the mobile node migrated to a network to which the first migration control unit is attached, generating a conversion packet which holds an updated address instead of the outdated address, and transmitting the conversion packet; and an address post unit for transmitting an address post message which indicates the updated address of the mobile node to the third migration control unit, the third migration control unit transmitting the packet received by the packet transfer unit, and the second migration control unit comprises a migration post unit for transmitting to the first migration control unit a migration post message which indicates the updated address of the mobile node when the mobile node migrates to another network; and a packet resumption unit for receiving the conversion packet from both the first migration control unit and the third migration control unit and resuming an original packet from the conversion packet, and the third migration control unit comprises a packet conversion unit for converting a destination address of a packet, the packet to be transmitted to the mobile node, into the updated address indicated by the address post message, the address post message sent by the first migration control unit, and transmitting it to the mobile node.

The migration post unit in the second migration

control unit may transmit an identification key included in the migration post message, the identification key being employed to identify the mobile node.

The identification key may be an address of the mobile node assigned at one network before the network to which the mobile node is currently attached.

The identification key may be an address of the mobile node assigned before its initial migration.

The second migration control unit may be constructed to transmit to the third migration control unit the packet which has the same format as the resumed packet.

The first migration control unit may further comprise an address hold unit for holding the outdated address and the updated address by corresponding them with each other; and an address comparison unit for comparing the destination address of the received packet with the outdated address, wherein the packet transfer unit generates the conversion packet and transmits it when the address comparison unit detects that the destination address of the received packet coincides with the outdated address.

The first migration control unit may further comprise an address hold unit for holding the outdated address and the updated address by corresponding them with each other; and an address comparison unit for comparing the destination address of the packet received by the packet transfer unit with the outdated address, wherein the address post unit transmits the address post message which indicates the updated address of the mobile node to the third migration control unit, the third migration control unit transmitting the packet received by the packet transfer unit, when the address comparison unit detects that the destination address of the packet coincides with the outdated address.

The second migration control unit may further comprise an address hold unit for holding the outdated address and the updated address by corresponding them with each other; and an address comparison unit for comparing the updated address with the destination address of the packet received from one of the first migration control unit and the third migration control unit, wherein the packet resumption unit resumes the original packet from the conversion packet when the address comparison unit detects that the updated address coincides with the destination address of the packet received from one of the first migration control unit and the third migration control unit.

The third migration control unit may further comprise an address hold unit for holding the outdated address and the updated address of the mobile node by corresponding them with each other; and an address comparison unit for comparing the outdated address in the address hold unit with the destination address of the packet to be transmitted to the mobile node, wherein the packet conversion unit converts the des-

mination address of the packet to be transmitted to the mobile node into the updated address which corresponds to the outdated address in the address hold unit when the address comparison unit detects the outdated address in the address hold unit coincides with the destination address of the packet.

There may be a plurality of the first migration control units, and the second migration control unit transmits the migration post message to at least one of the first migration control units.

The migration post unit in the second migration control unit may transmit the migration post message to the first migration control unit which is attached to the network to which the mobile node was attached before its migration, each of the first migration control units has a migration post unit for transmitting to one of the other first migration control units a migration post message to post the same address as the updated address indicated by the migration post message received from the second migration control unit, and each of the first migration control units has a migration post unit for transmitting a migration post message from one of the other first migration control units to another first migration control unit to post the same address as the updated address indicated by the received migration post message.

Each of the first migration control units and the second migration control unit may further comprise a pointer hold unit for holding pointers related to the first migration control unit to which the migration post message is transmitted, and wherein the migration post unit in each of the first migration control units and the migration post unit in the second migration control unit transmit the migration post message to each of the addresses related to each of the pointers.

Each of the pointers may be a broadcast address of the network to which one of the first migration control units is attached.

Each of the pointers may be an address which is assigned to one of the first migration control units uniquely.

Each of the pointers may be the address of the mobile node which is assigned when the mobile node is attached to the same network as is the first migration control unit, and the migration post unit in the first migration control unit and the migration post unit in the second migration control unit obtain the broadcast address of the network to which each of the first migration control units is attached with referring to the address of the mobile node, and transmits the migration post message to the obtained broadcast address.

The pointer hold unit in the second migration control unit may hold a pointer related to a first migration control unit for the latest migration, which is the first migration control unit being attached to one network before the network to which the mobile node is currently attached, and the pointer hold unit in the first migration control unit holds a pointer related to an-

other first migration control unit attached to the same network as was the mobile node attached before migrating to the network to which the first migration control unit is attached.

The second migration control unit may further transmit to the first migration control unit the pointer by sending thereto the migration post message, the pointer to be held by the first migration control unit.

The first migration control unit may store into the pointer hold unit the pointer when it receives from the second migration control unit the migration post message by corresponding the pointer with the updated address indicated by the received migration post message.

Each of the first migration control units may further comprise an address hold unit for holding the outdated address and the updated address by corresponding them with each other, wherein a migration post message unit stores into the address hold unit the outdated address and the updated address by corresponding them with each other when it receives from the second migration control unit the migration post message, while converts the updated address in the address hold unit into the updated address indicated by the migration post message when it receives from the first migration control unit the migration post message and the outdated address indicated by the migration post message coincides with one of the updated addresses in the address hold unit.

The first migration control unit may be placed on a gateway, which connects networks.

The first migration control unit may be placed on the network as an individual node.

The migration post unit in the second migration control unit may transmit the migration post message to a home migration control unit, the home migration control unit being the first migration control unit which is attached to a network where the mobile node left for its initial migration, and the home migration control unit may further comprise a home migration post unit for transmitting a migration post message to a first migration control unit for the latest migration, the first migration control unit for the latest migration being the first migration control unit which is attached to the network where the mobile node left for the latest migration, to post the same updated address as is indicated by the migration post message received from the second migration control unit.

The first migration control unit may further comprise a migration post unit for transmitting the migration post message indicating the updated address of the mobile node to one of the other first migration control units when the conversion packet destined for the outdated address of the mobile node was sent therefrom to the first migration control unit.

The migration post unit in the second migration control unit may transmit to the home migration control unit the migration post message where a home

address and the updated address are corresponded with each other, the home address assigned when the mobile node is attached to the same network as is the home migration control unit, and each of the packet transfer unit and the address post unit in the home migration control unit may transmit the conversion packet and the address post message respectively with referring to the above home address and the updated address.

The second migration control unit may further comprise an outdated address post unit for transmitting to the first migration control unit for the latest migration an outdated address post message where the outdated address and the home address are corresponded with each other, the outdated address being assigned to the mobile node before the latest migration, the home migration post unit in the home migration control unit may transmit to the said first migration control unit for the latest migration the migration post message where the above home address and the updated address are corresponded with each other, and the packet transfer unit and the address post unit in the first migration control unit for the latest migration may transmit the conversion packet and the address post message respectively in accordance with the outdated address and the updated address, the outdated address and the updated address being corresponded with each other via the home address.

The outdated address post unit in the second migration control unit may transmit the above outdated address post message at a migration of the mobile node preceding the latest migration, and each of the migration post units in the second migration control unit and the home migration post unit in the home migration control unit may transmit the above migration post message at the latest migration of the mobile node.

The second migration control unit may further comprise a home migration control unit pointer hold unit for holding a pointer related to the home migration control unit, the migration post unit in the second migration control unit transmits the migration post message to the address related to the pointer, the home migration control unit may further comprise a pointer hold unit for the latest migration for holding a pointer related to the first migration control unit for the latest migration, and the home migration post unit in the home migration control unit may transmit the migration post message to the address related to the pointer.

Each of the above pointers may be the broadcast address of the network to which each of the first migration control units is attached.

Each of the above pointers may be the address assigned to each of the first migration control units uniquely.

The second migration control unit may further comprise a pointer obtainment unit for requesting to

the first migration control unit for the latest migration the pointer related to the first migration control unit for the latest migration, and the migration post unit in the second migration control unit may post the obtained pointer to the home migration control unit together with the updated address by sending thereto the migration post message.

The migration post unit in the second migration control unit may post to the home migration control unit the pointer at the migration of the mobile node preceding the latest migration, while the migration post unit may post the above updated address at the latest migration of the mobile node.

The first migration control unit may further comprise an address post suppressing unit for suppressing transmission of the address post message from the address post unit to the third migration control unit, and the address post suppressing unit may suppress transmission of the address post message when none of the first migration control units is attached to the same network as is the mobile node.

The second migration control unit may further comprise a detect unit for detecting whether or not the first migration control unit is attached to the network to which the mobile node migrates, the migration post unit in the second migration control unit may transmit to the home migration control unit the migration post message which includes the detecting result of the above detect unit together with the updated address, the home migration post unit in the home migration control unit may transmit to the first migration control unit for the latest migration the migration post message which includes the detecting result of the above detect unit together with the updated address, and the address post suppressing unit in each of the home migration control unit and the first migration control unit for the latest migration may suppress the transmission of the address post message in accordance with the detecting result of the above detect unit.

The first migration control unit may further comprise a packet transfer suppressing unit for suppressing transfer of the packet conducted by the packet transfer unit.

The first migration control unit may further comprise an address post suppressing unit for suppressing transmission of the address post message from the address post unit to the third migration control unit, and the address post suppressing unit in the first migration control unit being attached to a network to which the mobile node is not attached, may suppress the transmission of the address post message when the packet transfer suppressing unit in the first migration control unit for the latest migration suppresses transfer of the packet.

The second migration control unit may further comprise a detect unit for detecting whether or not the packet transfer suppressing unit in the first migration



control unit suppresses the transfer of the packet, the first migration control unit being attached to the network to which the mobile node migrates, and the migration post unit in the second migration control unit transmits to the home migration control unit the migration post message which includes the detecting result of the above detect unit together with the updated address, the home migration post unit in the home migration control unit may transmit to the first migration control unit for the latest migration the migration post message which includes the detecting result of the detect unit together with the updated address, and the address post suppressing unit in each of the home migration control unit and the first migration control unit for the latest migration may suppress the transmission of the address post message in accordance with the detecting result of the above detect unit.

The packet transfer suppressing unit in the first migration control unit for the latest migration may suppress the transfer of the packet conducted by the packet transfer unit, when the packet transfer suppressing unit in the first migration control unit being attached to the network to which the mobile node migrates suppresses the transfer of the packet.

The above objects may also be fulfilled by a packet transfer migration control unit in a migration communication control device, the migration communication control device being constructed to control a communication between a mobile node and a partner node, the mobile node migrating across networks and obtaining an address assigned on each network while the partner node being a communication partner of the mobile node, comprising a packet transfer unit for receiving a packet which was transmitted by the partner node to an outdated address of the mobile node, the outdated address being assigned when the mobile node migrated to a network to which the packet transfer migration control unit is attached, generating a conversion packet which holds an updated address instead of the outdated address, and transmitting the conversion packet; and an address post unit for transmitting an address post message which indicates the updated address of the mobile node to the partner node, the partner node transmitting the packet received by the packet transfer unit.

The above objects may further be fulfilled by a mobile node migration control unit in a migration communication control device, the migration communication control device being constructed to control a communication between a mobile node which migrates across networks and obtains an address assigned on each network and a partner node which is a communication partner of the mobile node, being placed on the mobile node and comprising a migration post unit for transmitting to a packet transfer migration control unit a migration post message which indicates an updated address of the mobile node when the mobile

node migrates to another network, the packet transfer migration control unit for receiving a packet which was transmitted by the partner node to an outdated address of the mobile node, the outdated address assigned when the mobile node migrated to a network to which the migration control unit for packet transfer is attached, generating a conversion packet which holds the updated address instead of the outdated address, and transmitting the conversion packet; and a packet resumption unit for receiving the conversion packet from both the packet transfer migration control unit and the mobile node, and resuming an original packet from the conversion packet.

The above objects are finally fulfilled by a partner node migration control unit in a migration communication control device, the migration communication control device being constructed to control a communication between a mobile node which migrates across networks and obtains an address assigned on each network and a partner node which is a communication partner of the mobile node, being placed on the mobile node and comprising an address post message receiving unit for receiving an address post message which indicates an updated address of the mobile node from a packet transfer migration control unit, the packet transfer migration control unit transmitting an address post message which indicates the updated address of the mobile node to the partner node; and a packet conversion unit for converting a destination address of a packet, the packet to be transmitted to the mobile node, into the updated address indicated by the address post message, and transmitting it to the mobile node.

According to the above construction, the migration communication control device of the present invention transfers and converts the packet using the address assigned to the mobile node each time it migrates across networks, obviating particular addresses or devices such as the VIP address used conventionally. For this reason, the migration communication control device of the present invention can be applied to the existing partner node and mobile node so that they can communicate continuously by transferring the packet. Moreover, it is advantageous that the migration communication control device of the present invention is not necessarily applied to all the nodes to enhance communication efficiency; the present invention can be applied only to where necessary on the existing networks. More precisely, when any existing partner node communicates with the mobile node when it migrates, the packet can be transmitted directly from the mobile nodes to the existing partner node; and it can be transferred via the first migration control unit from the existing partner node to the mobile node, thereby enhancing communication efficiency.

Furthermore, when the partner node employs the migration communication control device of the

present invention, communication efficiency is further enhanced thanks to the direct packet transmission and reception made possible by posting the update address of the mobile node from the first migration control unit to the third migration control unit.

Also, the devices such as MSS or a gateway employing the VIP are not necessarily installed at every network to which the mobile node migrates. To be precise, according to the present invention, the continuous communication is implemented even when the mobile node migrates to a network at which no special devices including above ones are installed.

### BRIEF DESCRIPTION OF THE DRAWINGS

These and the other objects, advantages and features of the invention will become apparent from the following description thereof taken in conjunction with the accompanying drawings which illustrate a specific embodiment of the invention. In the drawings:

FIG. 1 is a block diagram depicting a construction of a migration communication control device in a first embodiment of the present invention;  
FIG. 2 is a block diagram depicting a detailed construction of the migration communication control device employed as a mobile node in the first embodiment of the present invention;  
FIG. 3 is a block diagram depicting a detailed construction of the migration communication control device employed as a gateway in the first embodiment of the present invention;  
FIG. 4 is a block diagram showing a detailed construction of the migration communication control device employed as a stationary node in the first embodiment of the present invention;  
FIG. 5 is a block diagram showing a detailed construction of the migration communication control device employed as an individual node in the first embodiment of the present invention;  
FIG. 6 is an illustration showing a first example of a network to which the migration communication control devices in FIG. 2, 3, 4 are attached;  
FIG. 7 is an illustration showing a second example of the network to which the migration communication control devices in FIG. 2, 3, 4 are attached;  
FIG. 8 is an illustration showing a third example of the network to which the migration communication control devices in FIG. 2, 3, 4 are attached;  
FIG. 9 is an illustration showing a fourth example of the network to which the migration communication control devices in FIG. 2, 3, 4 are attached;  
FIG. 10 is an illustration showing (a) data in a data hold unit 1 in the mobile node (b) data in a data hold unit 1 in the migration communication control devices each employed as the gateway, the stationary node, and the individual node.

FIG. 11 is an illustration showing a format of a packet in the first embodiment of the present invention;

FIG. 12 is an illustration showing a format of a packet in the first embodiment of the present invention;

FIG. 13 is an illustration showing a content of the data hold unit 1 in the migration communication control device employed as the gateway;

FIG. 14 is an illustration showing a content of the data hold unit 1 in the migration communication control device employed as the individual node;

FIG. 15 is an illustration showing an example of a network to which the migration communication control device is attached in a second embodiment of the present invention;

FIG. 16 is a detailed block diagram depicting a home migration communication control device in the second embodiment of the present invention;

FIG. 17 is an illustration showing a content of a home mobile host list hold unit in the second embodiment of the present invention;

FIG. 18 is a detailed block diagram depicting the visitor migration communication control device in the second embodiment of the present invention;

FIG. 19 is an illustration showing a content of a visitor mobile host list hold unit in the second embodiment of the present invention;

FIG. 20 is a detailed block diagram depicting a migration address unit in the second embodiment of the present invention;

FIG. 21 is an illustration showing a content of an address hold unit in the migration address unit in the second embodiment of the present invention;

FIG. 22 is a detailed block diagram depicting a migration address unit in the second embodiment of the present invention;

FIG. 23 is an illustration showing a content of the address hold unit in the migration address unit in the second embodiment of the present invention;

FIG. 24 is an illustration showing a format of a data packet in the second embodiment of the present invention;

FIG. 25 is an illustration showing a format of a packet transfer message in the second embodiment of the present invention;

FIG. 26 is an illustration showing a flow of a data packet transmitted between devices in the second embodiment of the present invention;

FIG. 27 is an illustration showing a communication sequence in FIG. 26;

FIG. 28 is an illustration showing a construction of each data packet in FIG. 26;

FIG. 29 is an illustration showing a change in the content of each hold unit in FIG. 26;

FIG. 30 is an illustration showing a flow of each data packet transmitted between devices at an operation example in the second embodiment of

the present invention;

FIG. 31 is an illustration showing a communication sequence in FIG. 30;

FIG. 32 is an illustration showing a construction of each data packet in FIG. 30;

FIG. 33 is an illustration showing a change in the address hold unit in each device in FIG. 33;

FIG. 34 is an illustration showing a flow of a data packet transmitted between devices at an operation example in the second embodiment of the present invention;

FIG. 35 is an illustration showing the communication sequence in FIG. 34;

FIG. 36 is an illustration showing a construction of each data packet in FIG. 34;

FIG. 37 is an illustration showing a change in the address hold unit in each device in FIG. 34;

FIG. 38 is an illustration showing a flow of each data packet transmitted between devices at an operation example in the second embodiment of the present invention;

FIG. 39 is an illustration showing a communication sequence in FIG. 38;

FIG. 40 is an illustration showing a construction of each data packet in FIG. 38;

FIG. 41 is an illustration showing a change in the address hold unit in each device in FIG. 38;

FIG. 42 is an illustration showing a flow of each data packet transmitted between devices in the second embodiment of the present invention;

FIG. 43 is an illustration showing a flow of each data packet transmitted between devices in the second embodiment of the present invention;

FIG. 44 is an illustration showing a flow of each data packet transmitted between devices in the second embodiment of the present invention; and

FIG. 45 is an illustration showing a flow of each data packet transmitted between devices in the second embodiment of the present invention.

## DESCRIPTION OF THE PREFERRED EMBODIMENT

### [Embodiment 1]

A construction of a migration communication control device in a first embodiment of the present invention is described hereunder with referring to FIGs. Hereinafter, the mobile node and partner node in the related art as well as in the summary of the invention are referred to as a mobile host and a stationary host, respectively.

FIG. 1 is an illustration showing the construction of the migration communication control device comprising a data hold unit 1, an application unit 2, a migration address unit 3, and a communication control unit 4.

The data hold unit 1 holds a couple of addresses

of a mobile host by corresponding them. Each of the addresses in the data hold unit 1 is assigned before and after a migration of the mobile host.

The application unit 2 checks a connection as well as monitors a timer. The unit 2 is relevant for a higher layer in OSI model, which includes an application layer. For example, the unit 2 operates as TCP at TCP/IP (Transmission Control Protocol/Internet Protocol) or a layer which is higher than TCP.

The migration address unit 3 processes a migration address with referring to data in the data hold unit 1. The concrete operation of the migration address unit 3 varies depending on a type of the migration communication control device comprising the unit 3, and this will be described in detail later.

The communication control unit 4 controls the communication. The unit 4 is relevant for a lower layer in the OSI model. For example, the unit 4 operates as a layer which is lower than IP at TCP.

The application unit 2 and the communication control unit 4 are the same units as ones implemented on a general host. Besides the unit 2 and 4, the migration communication device in the first embodiment of the present invention includes the data hold unit 1 and the migration address unit 3; thereby implements an operation unique to this case. That is, the data hold unit 1 and the migration address processing unit 3 are attached to the mobile host which migrates across networks, or a stationary host which is attached to a network fixedly (for example, a gateway or a server); otherwise, they operate alone. Each device comprising the unit 1 and 3 supports a continuous communication unaffected by migration of the mobile host besides providing its own function.

The data hold unit 1 and the mobile address unit 3, which are included in the devices attached to the network, are described in FIGs. 2, 3, 4, 5. FIG. 2 shows a migration communication control device where the unit 1 and the unit 3 are attached to the mobile host which migrates across networks; FIG. 3 shows a migration communication control device where the unit 1 and the unit 3 are attached to a gateway which connects the networks; FIG. 4 shows a migration communication control device where the unit 1 and the unit 3 are attached to the stationary host, which is the communication partner of the mobile host; and FIG. 5 shows a migration communication control device attached to the network itself.

The migration communication control device in FIG. 2 (hereinafter referred to as a mobile host) further includes the application unit 2, the communication control unit 4, and an address obtainment unit 25, besides the data hold unit 1 and the migration address unit 3.

Each of the application unit 2 and the communication control unit 4 operates as the above; while the unit 2 together with the unit 4 operate as a conventional stationary host.

The address obtainment unit 25 obtains an address of the mobile host assigned when it has migrated to another network. Although other options can be considered, such as employing a manual setting by an operator or communicating with a server computer which administrates addresses of the network, it is supposed here that the address is obtained in accordance with an instruction of a system administrator or the operator. The address obtainment unit 25 is also possessed by a general host and will not be described in detail.

The addresses held in the data hold unit 1 are obtained by the address obtainment unit 25.

The migration address unit 3 (enclosed with a broken line) consists of a response message transmission unit 20, a marked packet conversion unit 21, a migration address setting unit 26, a migration post transmission unit 27, a reception packet unit 28, and a marked packet resumption unit 29.

The response message transmission unit 20 transmits the packet which responds to the received packet if the response is needed.

The marked packet conversion unit 21 converts a packet received from the response message transmission unit 20 as well as the application unit 2 into a marked packet by converting the address of the received packet and marking the packet.

The migration address setting unit 26 stores the address obtained by the address obtainment unit 25 into the data hold unit 1. The address obtained by the unit 25 is the address of the mobile host assigned after the migration, and the unit 26 stores it into unit 1 by corresponding it to the address of the mobile host assigned before the migration.

The migration post transmission unit 27 posts via the communication control unit 4 that the address obtained by the unit 25 is held in the data hold unit 1 together with the correspondence between a couple addresses each of which assigned before and after the migration.

The reception packet unit 28 detects whether or not the received packet is marked, and sends the unmarked packet to the application unit 2 while sending the marked packet to the marketed packet resumption unit 29.

The marked packet resumption unit 29 resumes the marked packet.

The migration communication control device in FIG. 3 (hereinafter referred to as a gateway) further includes the application unit 2 and the communication control unit 4 besides the data hold unit 1 and the migration address unit 3 (enclosed with a broken line).

Each of the application unit 2 and the communication control unit 4 operates described the above, and the unit 2 together with the unit 4 operate as a conventional gateway.

The data hold unit 1 holds the correspondence between a couple of the addresses of the mobile host

each of which assigned before and after migration.

The migration address unit 3 consists of a reception packet unit 35, a migration post information unit 36, an address comparison unit 37, an address conversion post transmission unit 38, and a marked packet conversion unit 39.

The reception packet unit 35 detects whether or not the received packet is the packet comprising a migration post message, which is transmitted by the mobile host. The unit 35 then sends the migration post message to the migration post information unit 36 while sending the other packets to the address comparison unit 37.

In accordance with the migration post message received from the reception packet unit 35, the migration post information unit 36 stores in the data hold unit 1 the correspondence between a couple of the addresses of the mobile host each of which assigned before and after the migration. The unit 36 also sends the migration post message to the address conversion post transmission unit 38.

The address comparison unit 37 detects whether or not the destination address of the packet received from the reception packet unit 35 coincides with the address of the mobile host assigned before migration, which is held in the data hold unit 1. When they coincide with each other, the unit 37 further sends to the marked packet conversion unit 39 the address assigned after the migration, which corresponds to the address which coincides with the destination address, as well as the packet received from the reception packet unit 35. On the other hand, when they do not coincided with each other, the unit 37 implements a function of a gateway by sending the packet to the application unit 2.

The address conversion post transmission unit 38 transmits to the destination address of the above packet received from the reception packet unit 35 an address conversion post message to inform that the address of the mobile host changes when the address comparison unit 37 detects a coincidence. Also the unit 38 transmits the address conversion post message to the network which satisfies the following two conditions: (1) the network where the address assigned before the migration, which is held in the data hold unit 1, is other than 0 (2) the migration communication control device employs as the gateway is not attached to the network. When the address conversion post message is transmitted to the network, which satisfies the above conditions, its destination address is a broadcast address of the network. The broadcast address consists of a network part and a host part, and every bit of the host part is 1.

The marked packet conversion unit 39 generates a marked packet when the address comparison unit 37 detects a coincidence. The unit 39 generates it by marking a general packet after converting the destination address of the packet. Then, the unit 39 trans-

mits it.

The migration communication control device in FIG. 4 (hereinafter referred to as a stationary host) further includes the application unit 2 and the communication control unit 4 besides the data hold unit 1 and the migration address unit 3 (enclosed with a broken line).

Each of the application unit 2 and the communication control unit 4 operates as described the above, and the unit 2 together with the unit 4 operate as a conventional stationary host (not migrate).

The data hold unit 1 holds the correspondence between a couple of the addresses of the mobile host each of which assigned before and after the migration.

The migration address unit 3 consists of a reception packet unit 45, a marked packet resumption unit 46, an address conversion post information unit 47, an address comparison unit 48, and a marked packet conversion unit 49.

The reception packet unit 45 detects whether the received packet is the packet comprising the address conversion post message, the marked packet, or the other packets. The address conversion post message is transmitted by the gateway. Then the unit 45 sends the address conversion post message to the address conversion post information unit 47, the marked packet to the marked packet resumption unit 46, and the other packets to the application unit 2.

The marked packet resumption unit 46 resumes the unmarked packet from the marked packet, which is received from the reception packet unit 45.

The address conversion post information unit 47 obtains from the packet comprising the address conversions post message, which is received from the reception packet unit 45, the correspondence between the address of the mobile host assigned before the migration and the one assigned after the migration, and stores it into the data hold unit 1.

The address comparison unit 48 detects whether or not destination address of the packet received from the application unit 2 coincides with the address of the mobile host assigned before migration, which is held in the data hold unit 1. When they coincide with each other, the unit 48 further sends to the marked packet conversion unit 49 the address assigned after the migration, which corresponds to the address which coincides with the destination address, as well as the packet received from the application unit 2. On the other hand, when they do not coincided with each other, the unit 48 sends the packet to the communication control unit 4.

The marked packet conversion unit 49 generates a marked packet when the address comparison unit 37 detects a coincidence. The unit 49 generates it by marking a general packet after converting the destination address of the packet. Then, the unit 49 transmits it.

The migration communication control device in FIG. 5, which is attached to the network by itself, consists of the data hold unit 1, the migration address unit 3 (enclosed with a broken line), and the communication control unit 4.

The data hold unit 1 holds the correspondence between a couple of the addresses of the mobile host each of which assigned before and after the migration.

The migration address unit 3 consists of the reception packet unit 35, the migration post information unit 36, the address comparison unit 37, the address conversion post transmission unit 38, and the marked packet conversion unit 39. The units integrating the migration address unit 3 operate substantially same as equivalent units integrating the gateway in FIG. 3 except the following.

In FIG. 3 the address conversion post transmission unit 38 transmits the address conversion post message to the network satisfying both of the two conditions, which are described in the above; whereas, the address conversion post transmission unit 38 in FIG. 5 transmits the address conversion post message to the broadcast address of the network as long as the network satisfies the first condition, that is it transmits the address conversion post message to the network when the address assigned before the migration, which is held in the data hold unit 1, is other than 0.

FIG. 6 shows a first example of a network to which the migration communication control device as the mobile host in FIG. 2, the migration communication control device as the gateway in FIG. 3, and migration communication control device as the stationary host in FIG. 4 are attached. In the figure numeral 11 denotes a mobile host in FIG. 2, which migrates from a network A to a network B and obtains an address  $\alpha$  assigned on the network A as well as an address  $\beta$  assigned on the network B.

Numeral 12 denotes a stationary host in FIG. 3, which is attached to the network B and obtains an address  $\gamma$  assigned thereon.

Numeral 12' denotes a stationary host in FIG. 3, which is attached to the network A and obtains an address  $\gamma'$  assigned thereon.

Numeral 13 denotes a gateway in FIG. 3, which has an address g. The gateway 13 is attached to both the network A and the network B.

The address on each network is assigned by a system administrator.

FIG. 7 shows a second example of a network to which the mobile host in FIG. 2, the gateway in FIG. 3, and the stationary host in FIG. 4 are attached. The stationary host is not illustrated in FIG. 7 since its location does not affect the communication with the mobile host.

In the figure the mobile host 11 migrates across network 1-4, and obtains an address m, m', m'', m'''

assigned on each network respectively.

The network 5 as well as each of the network 1-4 (hereinafter referred to as the net 5, and the net 1-4 respectively) are connected with each other by a gateway 1-4, as shown in the figure.

A gateway 1-4 (hereinafter referred to as gw 1-gw 4) is the migration communication control device employed as the gateway in FIG. 3.

FIG. 8 shows a third example of the network to which the mobile host in FIG. 2, the gateway in FIG. 3, and the stationary host in FIG. 4 are attached. Construction of this network is substantially same as the second example of the network in FIG. 6 although operation thereof is different from the second example, which will be described later.

FIG. 9 shows a fourth example of the network to which the mobile host in FIG. 2, the migration communication control device in FIG. 5, the stationary host in FIG. 4 are attached. The migration communication control device as the stationary host will not be described here.

In the figure, numeral 11 denotes the mobile host which migrates across the network 1-4 and obtains the address  $m$ ,  $m'$ ,  $m''$ ,  $m'''$  assigned on each network respectively.

The network 5 as well as each of the network 1-4 (hereinafter referred to as the net 5, and the net 1-4 respectively) are connected with each other by a gw 1-4, as shown in the figure.

Each of the migration communication control unit 1-4 (hereinafter referred to as S1-S4) is relevant for the one in the FIG. 5.

An address used in the first embodiment of the present invention is described hereunder. Each address consists of a network part, which is assigned on each network and shared by every host attached to that network, as well as a host part, which is assigned to each host uniquely.

A broadcast address is a special kind of address, which can be divided into two types. The first one is the broadcast address used as the destination address in transmitting a packet from a network to another network, such as the broadcast address where every bit of the host part is 1. When the first type of the broadcast address is used as the destination address of the packet, the packet is transferred by the gateway to the network directed by the network part of the broadcast address. The other one is used in transmitting a packet within a network, such as the broadcast address where every bit of both the host part and the network part is 1. When the second type of the broadcast address is used as the destination address of the packet, the packet is transmitted to all the devices attached to the network, which includes the broadcast address. However, the gateway does not transfer the packet to any other network.

Operations of the migration communication control device in the first embodiment of the present in-

vention are described hereunder with referring to drawings.

(operation example in FIG. 6)

In FIG. 6, when the mobile host migrates from the network A to the network B, the migration communication control device is operated as follows.

In a first operation, the mobile host and the gateway operate when the mobile host migrates across networks.

In a second operation, the stationary host transmits a packet to an address of the mobile host which was assigned before the migration.

In a third operation, the stationary host transmits the packet to an address of the mobile host which has been assigned after the migration.

In a fourth operation, the mobile host receives the packet which is transmitted by the stationary host.

In a fifth operation, the mobile host sends a response message to the stationary host.

(first operation in FIG. 6)

In FIG. 6 the mobile host 11 attached to the network A (enclosed with a broken line) migrates to the network B to complete ongoing communication with the stationary host 12, which is attached to the network B. When migrating to the network B, the address obtainment unit 25 in the mobile host 11 (FIG. 2) obtains the address  $\beta$  assigned on the network B.

Immediately after obtaining the address  $\beta$ , the address obtainment unit 25 gives the address  $\beta$  to the migration address setting unit 26 and the migration post transmission unit 27. The migration address setting unit 26 stores the address  $\beta$  into the data hold unit 1 by corresponding it to the address  $\alpha$ , which is the address assigned before the migration. FIG. 10 (a) shows the content of the data hold unit 1. The migration post transmission unit 27 gives to the gateway 13 via the communication control unit 4 a packet comprising migration post message and the correspondence between the address  $\alpha$  and the address  $\beta$ , so that the gateway 13 will know that the mobile host 11 has migrated to the network B. The mobile host 11 can transmit the packet both before and after the migration. In FIG. 6 a packet 51 is transmitted before the migration, and its format is shown in FIG. 11 (a). As shown in FIG. 11 (a), the packet 51 consists of a destination address 91, a source address 92, and data 93. The data 93 further comprise a message type 98, an address before migration 94, and an address after migration 95.

Receiving from the communication control unit 4 the packet 51, the gateway 13 sends it to the reception packet unit 35, the unit 4 and the unit 35 being in FIG. 3. From the message type 98 in FIG. 11 (a), the gateway 13 identifies the packet 51 with the migra-

tion post message, and gives the packet 51 to the migration post information unit 36. The migration post information unit 36 obtains from the data 93 in the data packet 51 the address before migration  $\alpha$  and the address after the migration  $\beta$ ; then stores them into the data hold unit 1 by corresponding them with each other. The content of the data in the data hold unit 1 is shown in FIG. 10 (b).

Additionally, the destination address 91 of the packet in FIG. 11 (a), can be the broadcast address of the network A, where the network part names the network A and every bit of the host part is 1. When the broadcast address is employed, every stationary host attached to the network A, including the gateway 13, receives the correspondence of the addresses each of which assigned before and after the migration. In this case communication control unit 4 in the stationary host 12' receives the data packet 51, and gives it to the reception packet unit 45, the unit 4 and the unit 45 in FIG. 4. From the message type 98 in FIG. 11 (a), the reception packet unit 45 identifies the packet 51 with the migration post message, and gives the packet 51 to the address conversion post information unit 47. The unit 47 obtains from the data 93 in the data packet 51 the address before migration  $\alpha$  and the address after the migration  $\beta$  and stores them into the data hold unit 1 by corresponding them with each other. Once those addresses are stored in the data hold unit 1, the stationary host 12' can transmit a packet to the address assigned after the migration instead of transmitting it to the address before the migration, the same to other stationary hosts attached to the network A.

(second operation in FIG. 6)

In the second operation, the stationary host 12 transmits a packet to the address assigned before the migration after the mobile host 11 migrates to the network B and obtains the address  $\beta$  assigned on the network B. It is supposed that the mobile host 11 transmits the packet 51, which comprises the migration post message, to the gateway 13 rather than to the broadcast address of the network A.

The stationary host 12, which is not notified that the mobile host 11 has migrated to the network B, transmits the packet to the address  $\alpha$  of the mobile host, which was assigned before the migration. A packet 52 in FIG. 6 is transmitted by the stationary host 12 to the address  $\alpha$  of the mobile host 11, and its format is shown in FIG. 11 (f). The packet 52 is received by the gateway 13. Because the gateway 13 is located between the source address of the packet 52 and the address of the mobile host  $\alpha$  assigned before the migration, and also it is attached to the network A, to which the mobile host 11 was attached before the migration.

The gateway 13 employs its devices in FIG. 3 to

implement its functions including reception of the packet. That is, the communication control unit 4 in the gateway 13 receives the packet 52, and sends it to the reception packet unit 35 in the migration address unit 3. The reception packet unit 35 identifies the packet 52 with a general packet and gives it to the address comparison unit 37. The unit 37 compares the destination address  $\alpha$  of the packet 52 with the address before the migration, which is held in the data hold unit 1; then detects whether or not they are coincide with each other. When the destination address of the received packet does not coincide with the address assigned before the migration, the address comparison unit 37 sends the packet to the application unit 2. On the other hand, when they coincide with each other, the address comparison unit 37 obtains from the data hold unit 1 the address  $\beta$  of the mobile host assigned after the migration, which corresponds to the address  $\alpha$ ; then sends it both to the address conversion post transmission unit 38 and the marked packet conversion unit 39.

As is described the above, the packet 52 is transmitted to the address  $\alpha$  of the mobile host 11 by the stationary host 12. Therefore, the address conversion post transmission unit 38 notifies the stationary host 12 that the address of the mobile host 11 has changed by transmitting thereto the packet 53. FIG. 11 (b) shows the packet 53. Simultaneously, the marked packet conversion unit 39 converts the packet 52 into the packet 53 by rewriting the destination address of the packet 52 to the address  $\beta$  assigned after the migration, returning thereto the previous destination address of the packet 52 as additional information, and marking to show that its destination address has changed; then sends the packet to the communication control unit 4. Thereby, the packet 52, which is converted into the marked packet 52', is transferred from the address  $\alpha$  of the mobile host 11 assigned before the migration to the address  $\beta$  assigned after the migration. FIG. 12 (e) shows the packet 52'.

Receiving the packet 53 from the communication control unit 4 in the stationary host 12, it sends its packet 53 to the reception packet unit 45, the unit 4 and the unit 45 being in FIG. 4. From the message type 98 in FIG. 11 (b), the reception packet unit 45 identifies the packet 53 with the address conversion post message, and gives the packet 53 to the address conversion post information unit 47. The address conversion post information unit 47 obtains from the data 93 in the data packet 53 the address before migration  $\alpha$  and the address after the migration  $\beta$ ; then stores them into the data hold unit 1 by corresponding them with each other. Thereby, the stationary host 12 obtains the address of the mobile host 11 assigned after the migration, so that a direct communication between the stationary host 12 and the mobile host 11 is implemented.



In the second operation the migration communication control device comprising the units in FIG. 4 is employed as the stationary host 12. However, a conventional stationary host, which is not constructed as the migration communication control device can also be communication partner of the mobile host if it is attached to a network. Therefore, hereunder a communication between the mobile host 11 and the conventional stationary host is described.

When the conventional stationary host transmits a packet to the address of the mobile host 11 assigned before the migration after the mobile host 11 has migrated to another network, the gateway 13 transfers the packet to the address of the mobile host 11 assigned after the migration as well as sends to the stationary host the packet 53 comprising the address conversion post message in FIG. 11 (c). This operation is same as the above.

However, when receiving the packet 53, the stationary host disposes it since it does not support the address conversion post message and judges the packet 53 is not a required packet. Thus, the conventional stationary host cannot utilize the packet 53 to detect the address of the mobile host assigned after the migration nor hold the correspondence of the addresses each assigned before and after the migration.

Therefore, the stationary host gives the packet only to the address of the mobile host 11 assigned before the migration. Then, the gateway transfers the packet to the address of the mobile host 11 assigned after the migration, and the mobile host 11 receives the packet. The message from the mobile host 11, such as the response message, is transmitted to the stationary host directly, so that it is received by the stationary host without fail.

Thus, the conventional stationary host transmits a packet to the mobile host indirectly and receives a packet from the mobile host directly. Continuous communication unaffected by the mobile host's migration can be implemented, even when the conventional stationary host is employed.

(third operation in FIG. 6)

In the third operation, the stationary host 12 transmits the packet to the address  $\beta$  of the mobile host 11 assigned after the migration with referring to the correspondence of the addresses each assigned before and after the migration, which is held in the data hold unit 1. The third operation is described hereunder with referring to FIG. 4.

The stationary host 12 employs its devices in FIG. 4 to implement conversion of the destination address and the transmission of the packet, both of which integrate the third operation. That is, application unit 2 sends to the address comparison unit 48 the packet 54, whose destination address is the ad-

dress  $\alpha$  of the mobile host 11 assigned before the migration. FIG. 11 (f) shows a format of the packet 54. Then, the comparison unit 48 obtains the destination address of the packet 54 and detects whether or not it coincides with the address before the migration, which is held in the data hold unit 1.

The comparison unit 48 sends the packet 54 to the communication control unit 4 when the above addresses do not coincide with each other while it sends the packet 54 to the marked packet conversion unit 49 when the above addresses coincide with each other. In the third operation the coincidence is detected since the corresponded between the address  $\alpha$  and the address  $\beta$  is stored in the data hold unit 1. Therefore, the packet 54 is sent to the marked packet conversion unit 49. Then the marked packet conversion unit 49 obtains from the data hold unit 1 the address  $\beta$  of the mobile host assigned after the migration, which corresponds to the address  $\alpha$  as well as converts the packet 54 into the packet 54' by converting the destination address  $\alpha$  into the address  $\beta$ , returning thereto the original destination address  $\alpha$  as additional information, and marking the packet 54 to show that its destination address has changed; then sends the packet 54' to the communication control unit 4. FIG. 11 (c) shows a format of the packet 54'. Since the destination address of the packet 54' is an updated address of the mobile host 11, the packet 54' is given to the mobile host 11 without fail.

(fourth operation in FIG. 6)

In the fourth operation, the mobile host 11 receives the marked packet 54' and obtains the original unmarked packet 54 by resuming the packet 54'. This operation is described hereunder with referring to FIG. 2.

The mobile host 11 employs its devices in FIG. 2 to implement its operation. That is, the communication control unit 4 receives the packet 54' and sends it to the reception packet unit 28. The reception packet unit 28 detects that the received packet 54' is marked, and sends it to the marked packet resumption unit 29. The unit 29 obtains the original destination address  $\alpha$ , which is held in the additional information 97, and replaces the current destination address  $\beta$  of the packet 54' with the address  $\alpha$ . Then it sends the packet 54' to the application unit 2. Thus, the mobile host 11 can receive the packet destined for its outdated address.

(fifth operation in FIG. 6)

In the fifth operation, the mobile host 11 sends to the stationary host 12 a packet comprising a response message (hereinafter referred to as a response packet) or a packet excluding the response message (hereinafter referred to as a non-response



packet). A type of the received packet determines whether or not it is responded with the response packet.

When the packet 54' is responded with a response packet, the mobile host 11 employs its devices in FIG. 2 to send the response packet. That is, the response message transmission unit 20 builds the response packet, and sends it to the marked packet conversion unit 21 together with the destination address  $\alpha$  of the packet 54'.

The mobile host 12 also employs its devices to send the non-response packet 55. That is, the application unit 2 gives the address  $\alpha$  assigned before the migration and the non-response packet to the marked packet conversion unit 21. The unit 21 sends the received packet to the stationary host 12 via the communication control unit 4 without marking it. FIG. 11 (e) shows the packet sent by the unit 21 to the stationary host 12.

The communication control unit 4 in the stationary host 4 receives the packet 55, and gives it to the reception packet unit 45. The unit 45 detects that the packet 55 is the non-response packet, so that it gives the packet 55 to the application unit 2. Thus, the stationary host and the mobile host implement a continuous communication unaffected by mobile host's migration. Although the migration communication control device is employed as the stationary host 12 in this embodiment, the conventional host can also be employed to transmit the non-response packet.

In the above, the unmarked response packet and the unmarked non-response packet are sent to the mobile stationary host 12. On the other hand, hereunder the operation of the mobile host 11 at conversion of the response packet and the non-response packet into the marked ones is described. This will be employed effectively in a communication between mobile hosts.

Receiving the unmarked packet from the application unit 2, the marked packet conversion unit 21 generates a packet 55' where the destination address and the source address are the address  $\gamma$  of the stationary host 12 and the address  $\beta$  assigned after the migration respectively. Also in generating the packet 55', the application unit 2 gives to the received packet the address  $\alpha$  assigned before the migration as additional information as well as marks the received packet to indicate that the destination address has converted. FIG. 11 (d) shows a format of the packet 55'. Then the application unit 2 sends the packet 55' to the stationary host 12 via the communication control unit 4.

The communication control unit 4 in the stationary host 12 receives the packet 55', and sends it to the reception packet unit 45. Detecting the packet 55' is the marked packet, the reception packet unit 45 sends it to the marked packet resumption unit 46. The unit 46 resumes the packet 55' into the packet 55 by

unmarking it and replacing the source address thereof with the address  $\alpha$  assigned before the migration, which is held as the additional information. A format of the packet 55 is shown in FIG. 11 (e). Thus, the stationary host and the mobile host implement a continuous communication unaffected by mobile host's migration.

(operation example in FIG. 7)

In FIG. 7, when the mobile host migrates across the network 1, 2, 3, and 4, and obtains a temporary address assigned on each network, the newest address of the mobile host is transmitted to the stationary host, which operates as communication partner.

(migration from network 1 to network 2)

The address of the mobile host is  $m$  when it is attached to the network 1. When migrating from the network 1 to the network 2, the mobile host 11 replaces its address with  $m'$  assigned on the network 2. Then the mobile host 11 notifies the migration communication control device attached to the network 1 that it has migrated to the network 2 by sending thereto a packet comprising a migration post message. In FIG. 7 the migration communication control device gw 1, gw 2 attached to the network 1 receive the migration post packet 61, and store it into its own data hold unit 1. The operation in FIG. 7 is substantially same as the operation in FIG. 6 except that in FIG. 7 the packet 61 holds the address of the mobile host assigned before the last migration besides the correspondence of the addresses each assigned before and after the current migration. The address assigned before the last migration makes the gws prepare for further migration of the mobile host, which will be described later. A format of the packet 61 is shown in FIG. 12 (a). Since the migration from the network 1 to the network 2 is the first migration in FIG. 7, the packet 61 holds 0 at the address assigned before the last migration.

The gw 1 and the gw 2 store in the data hold unit 1 the correspondence of the addresses each assigned before and after the migration, as well as the address assigned before the last migration. As shown in FIG. 13 (a),  $m$ - $m'$  and 0 are stored in the data hold unit 1 of each of the gw 1 and the gw 2.

Then, the gw 1 and the gw 2 detects from 0 at the address assigned before the last migration that no migration had been conducted before the current migration.

The broadcast address of the network 1 can be employed as the destination address of the migration post packet 61. If the packet is destined for the broadcast address, every host attached to the network 1, which includes the gw 1 and the gw 2, will hold the correspondence of the addresses each of which as-

signed before and after the migration as well as the address assigned before the last migration. Thereby, the hosts attached to the network 1 can communicate with the mobile host directly.

(migration from network 2 to network 3)

When migrating from the network 2 to the network 3, the mobile host 11 obtains  $m''$  at the address assigned after the migration. Then the mobile host 11 notifies the gw 2 and a gw 3, both of which are attached to the network 2, that the mobile host 11 has migrated to the network 3 by transmitting thereto a packet comprising the migration post message, referred to as a packet 62 in FIG. 7. FIG. 12 (b) shows a format of the packet 62, which is transmitted to the gw 2. The broadcast address of the network 2 can be employed as the destination address of the packet 62. When the packet 62 is transmitted to the broadcast address of the network 2, every host attached to the network 2, which includes the gw 2 and the gw 3, holds the correspondence of the addresses each assigned before and after the migration.

The gw 2 employs its devices in FIG. 3 to process the packet 62. That is, receiving the packet 62, the gw 2 sends it to the migration post information unit 36 via the communication control unit 4 and the reception packet unit 35, then refers to the data hold unit 1 where  $m \rightarrow m'$  and 0 are still held at the address correspondence and at the address assigned before the last migration respectively. The migration post information post unit 36 obtains from the packet 62  $m'-m''$  as the newly assigned correspondence between the addresses each of which assigned before and after the current migration, the migration from the network 2 to the network 3. Then, it detects whether or not the address  $m'$  coincides with the address held in the data hold unit 1 as the address assigned after the last migration. Since the unit 36 detects the coincidence, it replaces the address  $m'$  in the unit 1 with the address  $m''$  as well as replaces the correspondence  $m-m'$  with the correspondence  $m-m''$ .

Also the migration post information unit 36 sends to the data hold unit 1 the address  $m$  assigned before the last migration together with the address correspondence  $m'-m''$  obtained from the current migration. Now the data hold unit 1 in the gw 2 holds the address  $m$  at the address assigned before the last migration and the address correspondence  $m'-m''$  at the correspondence of the addresses each of which assigned before and after the migration as well as the address 0 at the address assigned before the last migration as well as the address correspondence  $m-m'$  at the correspondence of the addresses each of which assigned before and after the migration. After updating as well as adding the addresses in the data hold unit 1, the migration post information unit 36 sends to the address conversions post transmission

unit 38  $m'-m''$  as the newly obtained correspondence of the addresses before and after the current migration.

The address conversion post transmission unit 38 detects the network satisfying the following conditions with referring to the data hold unit 1 and then transmits the address conversion post message to the broadcast address of the detected network. That is, the address conversion post message is transmitted to the network where the address assigned before the migration, which is held in the data hold unit 1, is other than 0 as well as the migration communication control device employed as the gateway is not attached. Although in the migration from the network 2 to the network 3, the data hold unit 1 holds  $m$  at the address assigned before the last migration, the gw 2 is attached to the network 1; therefore, the unit 38 does not transmit the address conversion post to the network 1.

The packet 62 is also received by gw 3. When receiving the packet 62, the gw 3 employs its own devices in FIG. 3 to process the packet 62, which is substantially same as does the gw 2 except the following. That is, the address conversion post transmission unit 38 of the gw 3 detects that the gw 3 is not attached to the network 1. Also it is detected that the mobile host 11, attached to the network 1, has the address  $m$  as the address assigned before the last migration. Therefore, the unit 38 of the gw 3 transmits to the broadcast address of the network 1 a packet comprising the address conversion post message, which is referred to as a packet 63. FIG. 12 (c) shows the packet 63.

The packet 63 is received by the gw 2, the gw 1, both of which are attached to the network 1. Although it is also received by the stationary host 11, this will not be described here. Obtaining the current address correspondence  $m'-m''$  from the packet 63, where  $m'$  coincides with the address which has been held in the hold unit 1 at the address obtained after the migration, the gw 1 changes the  $m-m'$  in the data hold unit 1 into the  $m-m''$  by replacing  $m'$  with  $m''$  as the address assigned after migration.

On the other hand, the data hold unit 1 of the gw 2 had gained from the packet 62 the above information before receiving the packet 63. Therefore the content of the unit 1 of the gw 2 does not change across reception of the packet 63. This is because the gws of the present invention locate on a gateway, which connects a couple of networks. Due to its location, each gw receives packets from two networks. However, actually the packet 62 is destined for the network 2 and the packet 63 is destined for the network 1. Therefore, even though the gw 2, which are attached to both the network 1 and the network 2, receives both the packet 62 and 63 by the gw 2, this will not cause any problem in the communication between the stationary host 12 and the mobile host 11.

FIG. 13 (b) shows the content of the data hold unit 1 in each of the gws.

(migration from network 3 to network 4)

When migrating from the network 3 to the network 4, the mobile host 11 obtains  $m''$  as the address assigned after the migration. Then the mobile host 11 sends to the gw 3 and a gw 4, both of which are attached to the network 3, a packet comprising the migration post message. The packet received by the gw 3 is referred to as a packet 64. The broadcast address of the network 3 can be employed as the destination address of the packet 64. When the packet 64 is destined for the broadcast address of the network 3, every host attached to the network 2, which includes the gw 3 and the gw 4, obtains from the packet the correspondence of the addresses each of which assigned before and after the migration from the network 3 to the network 4.

The gw 3 employs its devices in FIG. 3 to process the packet 64. That is, receiving the packet 64, the gw 3 converts the content of the data hold unit 1 by replacing the address correspondence  $m-m''$  with  $m-m'''$ , newly holding  $m'''-m''$  obtained from the packet 64 as well as the address  $m'$  assigned before the last migration. Then, the address conversion post transmission unit 38 of the gw 3 transmits the address conversion post message to the network satisfying the following condition. That is, the address conversion post message is transmitted to the network where the address assigned before the migration, which is held in the data hold unit 1, is other than 0 as well as the gw 3 itself is not attached. The packet including the address conversion post message is referred to a packet 65, and the packet is transmitted to the broadcast address of the network 1. FIG. 7 (c) shows the packet 65.

The packet 64 is also received by gw 4. When receiving the packet 64, the gw 4 renews the content of the data hold unit 1 by replacing  $m'-m''$  with  $m'-m'''$  as well as newly holding the address  $m'$  as the address assigned before the last migration. Further, the address conversion post transmission unit 38 of the gw 4 detects that the gw 4 is not attached to the network 2 which has the address other than 0 at the address assigned before the last migration; therefore, the unit 38 of the gw 4 transmits a packet comprising the address conversion post message, which is referred to as a packet 66, to the broadcast address of the network 2. FIG. 7 (c) shows the packet 66.

Receiving the packet 65, 66, the gw 2 and the gw 1 renew the content of its data hold unit 1, which is substantially the same as the above.

The gw 3 and the gw 2 receives the same information twice since the former receives the packet 64 and 65 while the latter receives the packet 65 and 66. This is because gws of the present invention locate on

a gateway and receives packets from a couple of networks, which is described the above.

FIG. 13 (c) shows the content of the data hold unit 1 in each of the gws. Thus, according to the gws of the present invention, the packet transmitted to any of the addresses  $m, m', m''$  is transferred by the gws to the updated address of the mobile host, the gws also notify the stationary host of the updated address.

For example, when the stationary host is not notified of the updated address of the mobile host and transmits a packet to the address  $m'$ , the packet is received by the gw 2 and the gw 3, both of which are attached to the network 2. Then, the gw 2 and the gw 3 transfers the packet to the updated address of the mobile host as well as notifies the stationary host of the updated address. Thereby, the stationary host obtains the updated address of the mobile host, so that it will be able to communicate with the mobile host directly. The packet destined for the address  $m'$  is received by both the gw 2 and the gw 3, since they are attached to the network 2. Thus, the mobile host receives the same packet twice, once from the gw 2 and the other time from the gw 3, and the stationary host receives the same message twice; however, the repeated packet or the message can be simply ignored, so that this will not cause any problem in the communication between the stationary host and the mobile host. The repeated packet or the message is observed when the two gws are attached to each network in FIG. 7; whereas it is not observed when only one migration communication control device is attached to each network, which will be described later at the operation in FIG. 9.

(operation example in FIG. 8)

In FIG. 6, FIG. 7, the stationary host transmits the data packet to the outdated address after mobile host notifies the gws that it has migrated to another network. Then the gws transmit the address conversion post message to the stationary host. However, in FIG. 8 the gws convert the destination address of data the packet from the outdated address into the updated address assigned after the migration instead of transmitting the address conversion post message.

A packet 71, 72 in FIG. 8 are substantially same as the packet 51, 52 in FIG. 6. The operation conducted before the packet 72 is transmitted by the stationary host 12 and is received by the gateway 13 is substantially same as the first operation in FIG. 6. The operation which follows reception of the packet 72 is described hereunder with referring to FIG. 3.

The gateway 13 employs its units in FIG. 3 to process the packet 72. The communication control unit 4 receives the packet 72 and gives it to the reception packet unit 35 in the migration address unit 3. Detecting that the packet 72 is a general packet, the re-

ception packet unit 35 sends it to the address comparison unit 37. The address comparison unit 37 detects whether or not the destination address of the packet 72 coincides with the address in the data hold unit 1 at the address assigned before the migration.

When no coincides is found, the address comparison unit 37 gives the packet 72 to the application unit 2. On the other hand, a coincidence is found, the address assigned after the migration, which corresponds with the address identical to the destination address of the packet 72, is obtained from the data hold unit 1, and is sent to the marked packet conversion unit 39 together with the packet 72. The marked packet conversion unit 39 generates a packet 72' where the destination address of the packet 72 is replaced with the address assigned after the migration, which is sent by the address comparison unit 37, the destination address of the packet 72 is added as additional address, and a mark is set to indicate that the destination address has converted. Then the packet 72' is sent to the communication control unit 4. FIG. 12 (e) shows a format of the packet 72', where identical numerals denotes the same units in FIG. 11. The packet 72' is sent to the mobile host 11 without fail since its destination address is the updated address thereof.

(operation example in FIG. 9)

In FIG. 9, the mobile host migrates across network 1, 2, 3, and 4. In FIG. 7 the gw 1-gw 4 are employed as the migration communication control devices; whereas in FIG. 9 the gw 1-gw 4 are employed simply as gateways to connect networks, and also another migration communication control device is attached to each network. The operation of the migration communication control device, which is connected to the network alone, at processing the migration post message or the address conversion post message is substantially same as one of the gw 1-gw 4 in FIG. 7. The flow of the migration post message and the address migration post message are mainly described hereunder.

(migration from network 1 to network 2)

When migrating from the network 1 to the network 2, the mobile host 11 sends a packet comprising the migration post message to the migration communication control device, which is attached to the network 1. In FIG. 9 (a) a migration post packet 81 is transmitted to a migration communication control device S1, which is attached to the network 1. The destination address of the packet 81 can be the broadcast address of the network 1.

The device S1 processes the packet 81 by employing its devices in FIG. 3. Receiving the packet 81, the device S1 stores into the data hold unit 1 the cor-

respondence of the addresses each assigned before and after the migration as well as the address assigned before the last migration. The migration post information unit 36 transmits the packet 81 to the address conversion post transmission unit 38; however, since the unit 38 detects that the address assigned before the last migration is 0, it does not transmit the address conversion post message to any network. The content of the data hold unit 1 in the S1-S4 are shown in FIG. 14 (a).

(migration from network 2 to network 3)

When migrating from the network 2 to the network 3, the mobile host 11 notifies the S2, which is attached to the network 2, that it has migrated to the network 3 by transmitting thereto the packet comprising the migration post message, which is referred to as a packet 82 in FIG. 9 (b).

The S2 employs its devices in FIG. 3 to process the packet 82. That is, it converts the content of the data hold unit 1 by renewing and adding new information, and finally holds in the unit 1 the address m'-m" at the correspondence of the addresses each of which assigned before and after the migration as well as the address m assigned before the last migration. Then, the migration post information unit 36 gives the newly obtained correspondence m'-m" to the address conversion post transmission unit 38.

The address conversion post transmission unit 38 detects whether or not the address assigned before the last migration, which is held in the data hold unit 1, is 0. If the address is not 0, the unit 38 transmits the address conversion post message to the broadcast address of the network which includes the detected address. In FIG. 9 (b) the address m is held at the address assigned before the last migration, so that the unit 38 transmits the packet 83 to the broadcast address of the network 1.

When receiving the packet 83, the migration communication control device S1, which is attached to the network 1, renews the content of the data hold unit 1 by newly holding the address correspondence m-m" as well as the address 0 at the address assigned before the last migration. Detecting 0 at the address assigned before the last migration, the address conversion post transmission unit 38 does not transmit the address conversion post to any network. The content of the data hold unit 1 in the S1-S4 are shown in FIG. 14 (b).

(migration from network 3 to network 4)

When migrating from the network 3 to the network 4, the mobile host 11 notifies the communication migration control device S3, which is attached to the network 3, that it has migrated to the network 4 by transmitting thereto a packet comprising the mi-

gration post message, referred to as a packet 84 in FIG. 9 (c).

The migration communication control device S3 employs its devices in FIG. 3 to process the packet 84. That is, it newly holds into the data hold unit 1 the address correspondence  $m''-m'''$  as well as the address  $m'$  assigned before the last migration. Then, the address conversion post transmission unit 38 in the S3 transmits a packet comprising the address conversion post message, referred to a packet 85 in FIG. 9 (c), to the broadcast address of the network 2 since the address  $m'$  is held at the address assigned before the last migration in the data host unit 1.

When receiving the packet 85, the migration communication control device S2 employs its devices in FIG. 3 to process it. That is, it newly holds into the data hold unit 1 the address correspondence  $m'-m''$  as well as the address  $m$  assigned before the last migration. Then, the address conversion post transmission unit 38 in the S2 transmits a packet comprising the address conversion post message, referred to a packet 86 in FIG. 9 (c), to the broadcast address of the network 2 since the address  $m$  is held at the address assigned before the last migration in the data hold unit 1.

When receiving the packet 86, the migration communication control device S1 employs its devices in FIG. 3 to process it. That is, it newly holds into the data hold unit 1 the address correspondence  $m-m''$  as well as the address 0 at the address assigned before the last migration. The address conversion post transmission unit 38 in the S1 does transmit the address conversion post since 0 is detected at the address assigned before the last migration. The content of the data hold unit 1 in each of the S1-S4 are shown in FIG. 14 (c). Thus, according to the migration communication control device S1-S4 of the present invention, the S1-S4 are notified of the updated address of the mobile host at every migration, so that the packet transmitted to any of the addresses  $m, m', m''$  is transferred thereby to the updated address of the mobile host. The S1-S4 also notify the stationary host of the updated address of the mobile host.

The operation in FIG. 9 differs from the operation in FIG. 7 in that each network has just one communication migration control device (one of the S1-S4), so that the migration post and the address conversion transmitted to S1-S4 are not duplicated.

In the format shown in FIG. 11 and 12, the mark 96 or the message type 93 indicates kind of packet. That is, mark 96 indicates whether or not the packet is marked while the message type 93 indicates whether it is the packet comprising the migration post message, the packet comprising the address conversion post message, and the general packet. Further, a protocol type can also be employed to indicate which migration communication control device is employed. For example, when TCP/IP is employed, the

protocol number at the IP header thereof distinguishes the packet employed in the embodiment from other packets. That is, when the protocol number in the packet is identical with the one, which has been assigned to the protocol number field, the packet is the one employed in the embodiment.

In the first embodiment of the present invention, a nonvolatile storage can be employed as the data hold unit 1 of the mobile host. If so, the communication can be resumed even after the host or the gateway is turned off as well as after the system is reset.

Also even when the stationary host employs the nonvolatile storage as the data hold unit 1, it can resume the communication, which has interrupted by the switch off or the system reset, rather fast since it obtains from another host the updated address of the mobile host instead of receiving from the gateway the address conversion post message which shows the updated address.

For example, it is supposed in FIG. 7 that the mobile host 11 migrates from the network 1 to the network 4. The data hold unit 1 of the migration communication device holds the address correspondence  $m-m''$  since it has communicated with the mobile host, which is attached to the network 4, at least once. According to the migration communication control device in the embodiment described the above, the packet is transferred from the outdated address to the updated address of the mobile host and the stationary host is notified of the updated address; therefore, even when the address information in the data hold unit is lost by switch off thereof, the stationary host will obtain the updated address. Restart of the communication can also be implemented by employing a specific host such as a server. That is, the server may be constructed to obtain the updated address of the mobile host at every migration, and give it to the stationary host whenever requested. In this case a packet comprising the address inquiry should be generated beforehand.

Also in the fifth operation in FIG. 6, the mobile host 11 employs the application unit 2 and sends to the marked packet conversion unit 21 the address assigned before the migration when transmitting the non-response address to the stationary host after it has migrated to another network. Instead of sending the non-response address, the application unit 2 can transmit a connection identifier to the marked packet conversion unit 21. In this case the data hold unit of the migration communication control device, employed as the mobile host, holds a correspondence between the connection identifier and the address that had been assigned when the connection was established instead of holding the correspondence between the correspondence of the addresses each assigned before and after the migration. Then, the unit 21 obtains the source address of the packet by detecting the address which corresponds to the identi-

fier, which is held in the data hold unit 1.

As is described the above, the mobile host can employ the broadcast address of the network when transmitting the migration post to the migration communication control devices. When the broadcast address is employed, every host attached to the network, to which the migration communication control device is also attached, obtains the updated address of the mobile host. This implements a direct communication between the mobile host and the stationary host, which improves efficiency of the communication.

The address assigned before the last migration, which is held in the hold unit 1, can be replaced with the broadcast address assigned to the network to which the mobile host is attached before the last migration. If the broadcast address is employed, the gateway employed as the migration communication control device (gws) or the migration communication control device (Ss) needs to include the broadcast address in the address conversion post message. In this case both devices can obtain the broadcast address from the data hold unit; therefore, the operation thereof at requesting the broadcast address will be eliminated.

When storage capacity of the data hold unit 1 is limited, the data hold unit 1 holds only the useful data by disposing the unuseful data, which is least recently retrieved therefrom by the address comparison unit.

#### [Embodiment 2]

In FIG. 15 network A, B, and C are connected in a line via gateways 143 and 143', the gateway 143 placing between the network A and B while the gateway 143' placing between the network B and C.

A home migration communication control device 101 including a migration address unit 144 is attached to the network A; a visitor migration communication control device 109 including a migration address unit 145 is attached to the network B; and a visitor migration communication control device 109' including a migration address unit 145' is attached to the network C. A mobile host 146 including a migration address unit 115 is attached to the network A as its home network, and a stationary host 151 including a migration address unit 125 is also attached to the network A.

The mobile host 146 migrates across the network A, B, and C. It has a home address  $\alpha$  assigned when it is attached to the network A, as well as other addresses assigned depending on where it migrates, such as a temporary address  $\beta$  on the network B and a temporary address  $\gamma$  on the network C.

Also each of the home migration communication control device 101, the visitor migration communication control device 109, 109' which are identical in its construction and the stationary host 151 has an address  $H_a$ ,  $V_a$ ,  $V_a'$ , and  $S_a$  respectively assigned on

the network.

Detailed function of the above devices 101, 109, 109', 146, and 151 is described hereunder, in which like components are labeled with like reference numerals.

[home migration communication control device 101]

When the mobile host 146 migrates from the home network to another network, it is assigned the temporary address. However if the stationary host 151 is not notified of that migration, it transmits an original data packet (hereinafter referred to as a non-capsulated data packet) to the home address  $\alpha$  of the mobile host 146. When the noncapsulated data packet is destined for the outdated address of the home mobile host 146, the home migration communication control device 101 transfers that noncapsulated data packet from there to the updated address, that is the temporary address  $\beta$  or  $\gamma$  of the mobile host. Then, the device 101 posts to the stationary host 151 the temporary address  $\beta$  or  $\gamma$  here, so that the stationary host 151 will be able to communicate directly with the mobile host. The device 101 also posts the same information to the visitor migration communication control device 109, 109', so that the devices 109, 109' will implement the same function with the home migration communication control device 101.

As shown in FIG. 16 the home migration communication control device 101 consists of the migration address unit 144 and a communication control unit 108. The migration address unit 144 further comprises a home mobile host (MH) list hold unit 102, a packet transfer unit 103, a mobile host (MH) transfer unit 104, an address inquiry unit 105, a packet monitoring unit 106, an address post unit 107.

Next the function of each component integrating the device 101 will be described. The communication control unit 108 mainly controls the communication of protocols located in lower layers including a physical layer, such as the protocol lower than IP.

The address post unit 107 receives from the mobile host 146 an data packet including an address post message. The address post message is generated when the mobile host 146 migrates to the network B or C, and posts the temporary address  $\beta$  or  $\gamma$  of the mobile host to the device 101. The unit 107 sends the address post message to the mobile host transfer unit 104 as well as sends a response message to the mobile host 146. FIG. 28 (3) is an example of the address post message, which includes the home address  $\alpha$  as well as the temporary address  $\beta$  or  $\gamma$  of the mobile host 146, a value of an autonomous flag F, and a broadcast address  $B_{ba}$ ,  $C_{ba}$  on the network B, C. The autonomous flag F will be described later. FIG. 28 (4) is an example of the response message.

A mobile host transfer unit 104 stores the address post message into the home mobile host list hold unit

102, notifies the visitor migration communication control device 109 or 109' of the migration of the mobile host 146 by sending thereto a mobile host transfer message, and receives the data packet including the response. Further, according to a direction given by the packet transfer unit 103, the unit 104 transmits the mobile host transfer message both to the stationary host 151 and the device 109 or 109'. The unit 103 gives the direction when the value of the autonomous flag F is 1.

FIG. 32 (3) and FIG. 36 (5) are examples of the mobile host transfer message including the home address  $\alpha$ , the temporary address  $\beta$  or  $\gamma$ , and the autonomous flag F. Since the mobile host transfer message is sent to the stationary host 151 is sent only when the autonomous flag F is 1; therefore, it does not necessarily include the value of the flag F. However, the identical message is sent both to the stationary host 151 and the visitor migration communication control device 109, 109' in this embodiment to simplify the construction of the mobile host transfer unit 104. FIG 32 (4) is an example of the response message.

As shown in FIG. 17, the home mobile host list hold unit 102 holds the home address  $\alpha$ , the temporary address  $\beta$ ,  $\gamma$ , the value of the autonomous flag F, and the broadcast address Bba, Cba on the network B, C, all of which are obtained from the mobile host transfer unit 104.

The packet monitoring unit 106 receives the packet destined for the home address  $\alpha$  of the mobile host 146, then sends it to the packet transfer unit 103 when the stationary host 151 transmits the packet to the home address  $\alpha$  of the mobile host 146 after the mobile host 146 has migrated to another network.

The packet transfer unit 103 has a payload including the nonencapsulated data packet and the packet transfer message informing the transfer of the non-encapsulated data packet, generates another data packet, and sends it to the temporary address  $\beta$ ,  $\gamma$  of the mobile host 146. FIG. 32 (2) is an example of the packet transfer message. As is described the above, the packet transfer unit 103 directs the mobile host transfer unit 104 to transmit the mobile host transfer message to the stationary host 151 only when the autonomous flag in the home mobile host list hold unit 102 shows the value of 1. The operation conducted when the flag F is 1 will be described later.

When the stationary host 151 has problems in communicating with the mobile host 146 such as receiving the unusual mobile host transfer message, the address inquiry unit 105 is employed to solve the problems. That is, receiving from the stationary host 151 an address inquiry message, the address inquiry unit 105 transmits to the stationary host 151 a data packet which responds to the address inquiry by showing the address to be used in the communication. The address inquiry message includes a type field 132, a flag field 133, a sequence field 134, and

a home address field 138, each of which having value 5, 1, a certain number, and  $\alpha$  respectively; while the response message includes a temporary address field 139 filled with the temporary address  $\beta$ ,  $\gamma$  as well as the flag field with 2, besides the type field 132, the sequence field 134, and the home address field 138 filled with the same values in the address inquiry message.

[visitor migration communication control device 109]

The visitor migration communication control device 109 implements the same function with the home migration communication control device 101. That is, when the stationary host 151 transmits an encapsulated data packet to the temporary address  $\beta$  of the mobile host 146, which is the updated address thereof since the mobile host has migrated to the network C, the visitor migration communication control device 109 transfers that encapsulated data packet from the temporary address  $\beta$  to temporary address  $\gamma$ . Then, the device 109 posts to the stationary host 151 the temporary address  $\gamma$ , so that the stationary host 151 will be able to communicate directly with the mobile host 146. However, whether or not the device 109 provides the above packet transfer service will be determined in accordance with a processing load put on the device 109 or with a initial setting given by a system operator; thus, the packet transfer service of the device 109 is not necessarily an obligation.

As shown in FIG. 18, the visitor migration communication control device 109 consists of the migration address unit 145 and the communication control unit 108. The migration address unit 145 further comprises the packet monitoring unit 106, a visitor mobile host list hold unit 110, a packet transfer unit 111, a mobile host transfer unit 112, a mobile host visit unit 113, and an autonomous support unit 114. The unit 106 and the unit 108 function the same as those in the home migration communication control device 101.

Receiving an autonomous packet transfer support check message inquiring if the visitor migration communication control device 109 provides the packet transfer service, the autonomous support unit 114 responds to it with the response message where the autonomous flag F shows 1 when the device 109 provides that service or 0 when it does not provide that service. FIG. 28 (1) is an example of the autonomous packet transfer support check message, while FIG. 28 (2) is an example of the response message including the autonomous flag F and the broadcast address Bba.

Receiving from the mobile host 146 the mobile host visit message which informs that the mobile host 146 has migrated to the network B, the mobile host unit 113 responds it with the response message after storing the mobile host visit message into the visitor mobile host list hold unit 110. The mobile host visit



message includes the home address  $\alpha$  and the temporary address  $\beta$  of the mobile host 146. FIG. 28 (5) is the format of the mobile host visit message, while the FIG. 28 (6) is the format of the response message.

Receiving from the mobile host transfer unit 104 in the device 101 the mobile transfer message informing that the mobile host 146 has migrated to the network C, the mobile host transfer unit 112 stores in the visitor mobile host list hold unit 110 the updated temporary address  $\gamma$  of the mobile host 146 and the value of the autonomous flag F by corresponding them to the home address  $\alpha$ . The unit 112 also transmits to the stationary host 151 the mobile host transfer message in accordance with the direction from the packet transfer unit 111, as does the mobile host transfer unit 104 in the device 101.

As shown in FIG. 19, the visitor mobile host list hold unit 110 holds the home address  $\alpha$  and the temporary address  $\beta$  on the network B, which are obtained from the mobile host 146 via the mobile host visit unit 113, as well as the temporary address  $\gamma$  and value on the autonomous flag F, which are obtained from the home migration communication control device 101 via the mobile host transfer unit 112.

The packet transfer unit 111, as does the packet transfer unit 103 in the home migration communication control device 101, transmits to the temporary address  $\gamma$  the data packet including the transfer message as well as orders the mobile host transfer unit 112 to transmit the mobile host transfer message.

[mobile host 146]

As shown in FIG. 20, the mobile host 146 includes the migration address unit 115, an address obtainment unit 116, the communication control unit 108, and an application processing unit 124 which mainly controls the communication of protocols located in higher layers including an application layer, such as TCP or layers located higher than it.

The migration address unit 115 comprises the a packet transmission unit 117, a transfer packet reception unit 118, an address hold unit 119, a migration unit 120, an autonomous support unit 121, an address post unit 122, a mobile host visit unit 123.

The migration address unit 115 comprising the above units is employed in transfer of data to the temporary address  $\beta$  or  $\gamma$  when the mobile host 146 migrates to the network B or C. Also receiving the data packet destined for the temporary address  $\beta$  or  $\gamma$  including the packet transfer message and the noncapsulated data packet, the device 115 transmits the noncapsulated data to the application processing unit 124.

In accordance with the order given by the application processing unit 124 when the mobile host migrates to the network B, C, the migration unit 120 con-

trols the address obtainment unit 116, the autonomous support unit 121, the address post unit 122, the mobile host visit unit 123, and the address hold unit 119.

Directed by the migration processing unit 120, the address obtainment unit 116 obtains the temporary address  $\beta$ ,  $\gamma$  of the mobile host 146 assigned when it migrates to the network B, C respectively. BOOTP in "Bill Croft and John Gilmore, BOOTSTRAP PROTOCOL RFC951, Sep., 1985" is an example of obtaining the temporary address; besides employing the BOOTP, the operator may input the temporary address  $\beta$ ,  $\gamma$  assigned by a system administrator of the network B, C.

Directed by the migration unit 120, the autonomous support unit 121 sends the autonomous packet transfer support check message to inquire if the visitor migration communication control device 109, 109' attached to the network B, C provides the packet transfer service and receives the response message to the inquiry. The autonomous packet transfer support check message is also sent to obtain the broadcast address Bba and Cba on the network B and C respectively.

Directed by the migration unit 120, the address post unit 122 sends the address post message to notify the home migration communication control device 101 of the temporary address  $\beta$ ,  $\gamma$ . The address post message also informs whether or not the device 109, 109' provides the packet transfer service as well as the broadcast address Bba, Cba on the network B, C. If the response message from the visitor migration communication control device 109, 109' has the value 1 of the autonomous flag F, the mobile host visit unit 123 transmits to the visitor migration communication control device 109, 109' the mobile host visit message including the home address  $\alpha$  as well as the temporary address  $\beta$ ,  $\gamma$  respectively.

As shown in FIG. 21, the address hold unit 119 previously holds the home address  $\alpha$  of the mobile host 146 and the broadcast address Aba on the network A. Now, the unit 119 newly holds the temporary address  $\beta$  or  $\gamma$  obtained from the address obtainment unit 116 via the migration unit 120 and the broadcast address Bba or Cba obtained from the autonomous support unit 121 via the migration unit 120.

When the mobile host 146 is attached to the network A and receiving a data packet destined for the home address  $\alpha$ , the transfer packet reception unit 118 sends data etc. in the noncapsulated data packet to the application processing unit 124. On the other hand, when the mobile host 146 is attached to the network B and receiving a data packet destined for the temporary address  $\beta$ , the data packet including the packet transfer message and the noncapsulated data packet destined for  $\alpha$ , the unit 118 sends to the application processing unit 124 data etc. in the noncapsulated data. Thus, the application processing



unit 124 receives the data without being affected by the migration of the mobile across the networks.

Receiving the data to be transmitted and the instruction from the application processing unit 124, the packet transmission unit 117 generates a noncapsulated data packet whose destination address is the home address  $\alpha$  and transmits it.

[stationary host 151]

As shown in FIG. 22, the stationary host 151 comprises the migration address unit 125 and the application processing unit 161 which mainly controls the communication of a protocol located in higher layers including application layer, such as TCP or layers located higher than the TCP and the communication control unit 108.

The migration address unit 125 comprises a transfer packet transmission unit 126, a packet reception unit 127, an address hold unit 128, an address inquiry unit 129, and the mobile host transfer unit 130.

The migration address unit 125 comprising the above units generates a noncapsulated data packet and sends it to the home address  $\alpha$  when it is not notified that the mobile host 146 migrate to the network B or C and obtained the temporary address  $\beta$  or  $\gamma$  respectively. The unit 125 also generates an encapsulated data packet including as a payload the noncapsulated data packet and a data transfer message, which informs transfer of the noncapsulated data packet and sends it to the temporary address  $\beta$ ,  $\gamma$ , when it is notified of the migration.

Receiving from the home migration communication control device 101 and the visitor migration communication control device 109, 109' the data packet including the mobile host transfer message which informs the migration of the mobile host 146, the mobile host transfer unit 130 stores into the address hold unit 128 the home address  $\alpha$  and the temporary address  $\beta$  or  $\gamma$  of the mobile host 146 assigned on the network B or C respectively.

As shown in FIG. 23, the address hold unit 128 holds the home address  $\alpha$ , the temporary address  $\beta$  or  $\gamma$  by corresponding them.

Directed by the application unit 161, the transfer packet transmission unit 126 generates a data packet destined for the home address  $\alpha$ , and transmits it. However, if the address hold unit 128 holds the temporary address  $\beta$  or  $\gamma$  besides the home address  $\alpha$ , the unit 126 generates an encapsulated data packet destined for the temporary address  $\beta$  or  $\gamma$ , which includes as a payload a noncapsulated data packet and a packet transfer message, which informs transfer of the noncapsulated data packet, and transmits it.

As is described the above, both the home migration communication control device 101 and the visitor migration communication control device 109, 109' generate the encapsulated data packet includ-

ing the packet transfer message and the noncapsulated data and transmits it to the current temporary address of the mobile host 146. Owing to the device 101 or 109, 109', the stationary host 151 is able to transmit to the mobile host 146 both the noncapsulated data packet destined for the home address  $\alpha$  and the encapsulated data packet destined for the temporary address  $\beta$  or  $\gamma$  without failure even when the address hold unit 128 fails to hold the current temporary address  $\beta$  or  $\gamma$  and the stationary host 151 transmits the data packet to the outdated address of the mobile host 146.

The packet reception unit 127 receives a data packet which is sent from the mobile host 146 and has Sa as its destination address, and sends the data etc. in it to the application unit 161.

When the address inquiry unit 129 has problems such as that it received an illegal mobile host transfer message or that it cannot communicate with the mobile host 146 successfully, it transmits a data packet including an address inquiry message in order to inquire of the host migration communication control device 101 the address which is currently used to communicate with the mobile host 146.

[construction of data packet]

As shown in FIG. 24 (a), (b), (c), there are three kinds of data packets, each data packet 210, 220, 230, includes each of header 211, 221, 231 and payload 212, 222, 232 respectively.

The header 211 of the data packet 210 includes a destination address 201, and a source address 202. Also the payload 212 consists of a transmission data 203.

The header 221 of the data packet 220 includes the destination address 201 and the source address 202. Also the payload 222 consists of a message 204.

The header 231 of the data packet 230 includes the destination address 201 and the source address 202. Also the payload 232 consists of the message 204, which is employed as the packet transfer message, and a noncapsulated data packet 210. Also each header 211, 221, 231 includes information showing presence or absence of the message 204 as a protocol number etc.

The message 204 includes some of the fields in FIG. 25 in accordance with its type.

The type of the message 204 is indicated in the message type field 132. Besides the above types, the message 204 is also employed as an echo message for examining whether or not a host employs an appropriate operation in accordance with the message.

A flag field 133 indicates whether or not the message 204 is a response. When the message 204 is not the response, the field 133 further indicates whether or not the message 204 requests a response.

A sequence field 134 gives a single number both to the request message and its response message, thereby the request message and the response message are corresponded.

An autonomous flag field 135 contains a value of the autonomous flag F indicating whether or not the visitor migration communication control device 109,109' provide the packet transfer service.

A counter field 136 contains a counter indicating the number of the visitor migration communication control devices employed to transfer the encapsulated data packet consisting of the packet transfer message and the noncapsulated data packet. The visitor migration communication control device increments the counter in the received message packet by 1, and gives it to the message to be transmitted. When the incremented number is greater than the predetermined number, the received message packet is disposed.

A status field 137 of the response message indicates presence or absence of an error in a transmission/reception of the data packet. For example, it indicates an error in authentication information, which will be described later, or the address inquiry message which cannot or should not be responded.

A home address field 138, a temporary address field 139, and a broadcast address field 140 indicates the home address as well as the temporary address of the mobile host 146 or the broadcast address on its home network or on the network it migrates. However, what the broadcast address field 140 indicates depends on type of the message 204. Whether the message 204 is the request or the response also decides the content of the broadcast address field 140.

The authentication information field 141 indicates if a source address coincides with the sender's address.

[outline of communication operation]

The home migration communication control device 101 and the visitor migration communication control device 109,109' is basically employed to transfer the data packet transmitted by the stationary host 151 as well as post to the stationary host 151 the updated temporary address of the mobile host 146. Understanding of such operations will be helped by the following two points.

1. Transfer of the data packet and posting of the updated temporary address are conducted only when the mobile host 146 migrates from its home network to another network. The home network refers to the one to which the home migration communication control device is attached.
2. Posting of the updated temporary address is conducted only when the autonomous flag F is 1, which indicates the visitor migration communication control device 109, attached to the same net-

work as is the mobile host 146, provides the packet transfer service. Otherwise, the data packet transmitted by the stationary host 151 to the posted temporary address will not be received by the mobile host 146 when the mobile host 146 migrates to another network.

[communication operation 1]

An example of the communication operation is described hereunder. In the communication operation 1 the visitor migration communication control device 109,109' provides the packet transfer service when the mobile host 146 migrates from the network A to the network B, further from the network B to the network C.

[migration from network A to network B]

The operation at the migration of the mobile host 146 from the network A to the network B is described with referring to FIGs. 26-29. FIG. 26 shows a flow of the data packet transmitted between the devices; FIG. 27 shows a communication sequence of the data packet; FIG. 28 shows construction of each data packet; and FIG. 29 shows the content of the address hold unit 119 etc.

When the mobile host 146 is attached to the network A, the home mobile host list hold unit 102 in the home migration communication control device 101 holds the home address  $\alpha$  both as the home address and the temporary address of the mobile host 146. Thereby the home migration communication control device 101 detects that the mobile host 146 is attached to the network A.

The address hold unit 119 in the mobile host 146 holds the home address  $\alpha$  and the broadcast address  $A_{ba}$  on the network A.

When the mobile host 146 migrates to the network B, the application unit 124 orders the operation of the migration unit 120 in accordance with the instruction given by the operator. The temporary address  $\beta$  is assigned to the mobile host 146 on the network B, and the address obtainment unit 116 obtains it. The migration unit 120 stores into the address hold unit 119 the temporary address  $\beta$  together with the home address  $\alpha$  and the broadcast address  $A_{ba}$ .

(1) The autonomous support unit 121 transmits to the visitor migration communication control device 109, which is attached to the network B, the data packet including the autonomous packet transfer support check message 147 which holds the home address  $\alpha$  and the temporary address  $\beta$ . The destination address of the data packet is the broadcast address shared by every network, such as an address where every bit is 1. The message 147 does not necessarily hold the home address  $\alpha$  and the temporary address  $\beta$  although

they can be used in checking the security of the network if it does. Also the message 147 holding the home address  $\alpha$  and the temporary address  $\gamma$  can take the place of a mobile host visit message 146, which will be described later.

(2) The autonomous support unit 114 in the visitor migration communication control device 109 responds to the autonomous support unit 121 with the response message 147R where broadcast address Bba is set and the autonomous flag F in the autonomous flag field 135 indicates 1 to inform that the device 109 provides the packet transfer service.

The mobile host 146 transmits the data packet to the visitor migration communication control device 109. The broadcast address Bba is employed as the destination address of the data packet and it is set in the response message 147R; however, this is not an obligation.

That is, when the response message 147R does not hold the broadcast address Bba, the following means can be employed. First, the broadcast address shared by every network can be employed, which is described in the above. Second, the source address, which is set in the header of the data packet comprising the response message 147R, can be employed. Third, a so called name service can be employed, where a server device on the network system informs the broadcast address Bba. Finally, when the address assigned to each of the devices, which are attached to the network, consists of the network address being unique for the network and a device address being unique for the devices, and the broadcast address on each network consists of such network address and the device address where the value of every bit is 1, the network address Bba can be generated by employing the network address included in the temporary address  $\beta$  of the mobile host 146.

(3) The address post unit 122 transmits to the home migration communication control device 101 the address post message 148. The message 148 includes the value 1 of the autonomous flag F, which is obtained from the response message, home address  $\alpha$ , the temporary address  $\beta$  on the network B, and the broadcast address Bba, and the broadcast address Aba is the destination address of the address post message 148.

When the address post unit 107 in the home migration communication control device 101 receives the address post message 148, the mobile host transfer unit 104 stores in the home mobile host list hold unit 102 the temporary address  $\beta$ , the value 1 of the autonomous flag 1, and the broadcast address Bba by corresponding them to the home address  $\alpha$ . Since the home address  $\alpha$

had been stored as the temporary address before the temporary address  $\beta$  was stored, the mobile host transfer unit 104 knows that the mobile host 146 has migrated from the network A to the network B; therefore, it does not transmit the mobile host transfer message to the visitor migration communication control device 109, 109'. That is, the data packet transmitted by the stationary host 151 to the home address  $\alpha$  of the mobile host 146 is received by the home migration communication control device 101 and transferred thereby to the temporary address  $\beta$ ; therefore, the visitor migration communication control device 109, 109' is not employed here.

(4) The address post unit 107 notifies the address post unit 122 that it has received the address post message 148 by sending the response message 148R.

(5) Since the visitor migration communication control device 109 provides the packet transfer service, the mobile host visit unit 123 transmits to the visitor migration communication control device 109 the mobile host visit message 149 including the home address  $\alpha$  and the temporary address  $\beta$ , so that the device 109 is notified that the mobile host 146 has migrated to the network B. The mobile host visit message 149 is destined for the broadcast address Bba.

The mobile host visit unit 113 in the visitor migration communication control device 109 receives the mobile host visit message 149 and stores into the visitor mobile host list hold unit 110 the home address  $\alpha$  as well as the temporary address  $\beta$ . The temporary address  $\beta$  is stored also as the updated temporary address of the mobile host 146, which will be assigned when the mobile host 146 migrates from the network B to another network; thereby, the visitor migration communication control device 109 detects that the mobile host is currently attached to the network B.

(6) The mobile host visit unit 113 notifies the mobile host visit unit 123 by sending the response message 149R that it has received the mobile host visit message 149.

[communication between the stationary host 151 and the mobile host 146 on the network B]

The operation at the communication between the stationary host 151 and the mobile host 146 when the mobile host is attached to the network B is described hereunder with referring to FIGs. 30-33, which are relevant for FIGs. 26-29.

(1) The application unit 161 in the stationary host 151 directs the transmission of the noncapsulated data packet, whose destination is the home address  $\alpha$ , despite the migration of the mobile host 146. Immediately after the mobile host 146

migrates to the network B, that is, when the address hold unit 128 does not hold the home address  $\alpha$  and the temporary address  $\beta$ , the transfer packet transmission unit 126 is not notified of the migration; therefore, it generates the noncapsulated data packet 152 and transmits it to the home address  $\alpha$  in accordance with the direction from the application unit 151.

The noncapsulated data packet 152 is not received by the mobile host 146, which is not attached to the network A, but by the packet monitoring unit 106 in the home migration communication control device 101 since the home mobile host list hold unit 102 in the device 101 holds the home address  $\alpha$  as well as the temporary address  $\beta$ , which coincides with the destination address of the noncapsulated data packet 152.

(2) The packet transfer unit 103 in the home migration communication control device 101 generates an encapsulated data packet including the noncapsulated data packet 152, which is received by the packet monitoring unit 106, and the packet transfer message 153, which informs the transfer of the noncapsulated data packet 152; and transmits it to the temporary address  $\beta$ . The packet transfer message 153 includes the value 0 in the field 133, which indicates that no response is requested, as well as the value 0 on the counter in the field 136, which indicates that the packet transfer message is the first message added to the noncapsulated data packet 152. As is described, no response is requested by the packet transfer message 153. That is, the application unit 161 of the stationary host 151 and the application unit of the mobile host 146, rather than the home migration communication control device 101 and the migration address unit 115, confirm that the mobile host 146 receives the noncapsulated data packet 152.

The transfer packet reception unit 118 in the mobile host 146 receives the encapsulated data packet including the packet transfer message 153 and the noncapsulated data packet 152, since it is destined for the temporary address  $\beta$ , which is held in the address hold unit 119. The unit 118 then detects that the destination address of the noncapsulated data packet 152 is the home address  $\alpha$ , and sends the data etc. in the noncapsulated data packet 152 to the application unit 124.

Thus, the communication between the application unit 124 and the application unit 161 is not affected by the migration of the mobile host 146. (3) The packet transfer unit 103 transmits the encapsulated data packet including the data packet transfer message. It also directs, after detecting that the autonomous flag F indicates 1, the mobile host transfer unit 104 to transmit to the sta-

tionary host 151 the data packet including the mobile host transfer message 154 where the home address  $\alpha$  and the temporary address  $\beta$  are set. Finally, the unit 104 transmits the data packet to the stationary host 151.

The mobile host transfer unit 130 in the stationary host 151 receives the mobile host transfer message and stores into the address hold unit 128 the home address  $\alpha$  and the temporary address  $\beta$ .

(4) The mobile host transfer unit 130 responds to the mobile host transfer unit 104 with the response message 154R.

(5) When the application unit 161 directs the transmission of the noncapsulated data packet to the home address  $\alpha$  after the address hold unit 128 holds the home address  $\alpha$  and the temporary address  $\beta$ , the transfer packet transmission unit 126 first generates a noncapsulated data packet destined for the home address  $\alpha$ , then generates an encapsulated data packet including it and a packet transfer message 155. The encapsulated data packet is then transmitted to the temporary address  $\beta$ . Thus, once the home migration communication control device 101 notifies the stationary host 151 of the home address  $\alpha$  and the temporary address  $\beta$ , the stationary host 151 is able to transmit the data packet to the temporary address  $\beta$  of the mobile host 146, and the home migration communication control device 101 is not employed.

On the other hand, when data is transmitted from the mobile host 146 to the stationary host 151, the  $S_a$  is employed as the destination address  $\alpha$  and the home address is employed as the source address; and the noncapsulated data packet is transmitted from the address  $\alpha$  to the address  $S_a$ .

Thus, even when all the noncapsulated data transmitted by the stationary host 151 is destined for the home address  $\alpha$ , the home migration communication device 101 transfers the data to the updated temporary address of the mobile host; thereby, the communication between the mobile host 146 and the stationary host 151 is implemented, and the conventional device can be employed as the stationary host 151, which broadens a practicability of the network system.

Whereas, when the network system checks the original source address of the data packet or a transfer path of the data packet, the transmission unit may be built in the mobile host 146 like the transfer packet transmission unit 126 in the stationary host 151, and also the reception unit may be built in the stationary host 151 like the transfer packet reception unit 118 in the mobile host 146; and the encapsulated data packet including the packet transfer message and the noncapsulated data packet may be transmitted therebetween.

[migration from network B to network C]

The operation at the migration of the mobile host 146 from the network B to the network C is described hereunder with referring to FIGs. 34-37, relevant for FIGs. 26-29.

(1)-(4) The operation related to transmission of an autonomous packet transfer support check message 147', a response message 147R', an address post message 148', and a response message 148' between the mobile host 146 and the visitor migration communication control device 109' is substantially same as the operation related to transmission of messages between the mobile host 146 and the visitor migration communication control device 109, which is conducted when the mobile host 146 migrates to the network B. However, the operation at the migration from the network A to the network B and the operation at the migration from the network B and the network C are different from each other in part of the operation of the home migration communication control device 101 conducted after it responds to the received address post message 148' with the response message 148R.

(5) When the address post unit 107 receives the address post message 148', the mobile host transfer unit 104 in the home migration communication control device 101 detects that the mobile host been attached to the network B before migrating to the network C since the temporary address  $\beta$  has been stored as the temporary address. Then, the mobile host transfer unit 104 sends to the visitor migration communication control device 109 the data packet including both the home address  $\alpha$  and the temporary address  $\gamma$ , so that the device 109 transfers the data packet transmitted by the stationary host 151 from the temporary address  $\beta$  to the temporary address  $\gamma$ . The data packet received by the visitor migration communication control device is destined for the broadcast address Bba.

In accordance with the address post message 148', the mobile host transfer unit 104 stores into the home move host list hold unit 102 the temporary address  $\gamma$ , the value 1 of the autonomous flag F, and the broadcast address Cba by corresponding them to the home address  $\alpha$ .

Receiving the data packet including the mobile host transfer message 150, the mobile host transfer unit 112 in the visitor migration communication control device 109 stores into the visitor mobile host list hold unit 110 the temporary address  $\gamma$  newly assigned to the mobile host 146 and the value 1 of the autonomous flag F by corresponding them to the home address  $\alpha$ .

(6) The mobile host transfer unit 112 notifies the mobile host transfer unit 104 that it has received

the mobile host transfer message 150 by sending thereto the response message 150R.

(7), (8) The transmission of a mobile host visit message 149' and a response message 149R' between the mobile host 146 and the visitor migration communication control device 109', which is conducted when the device 109' provides the packet transfer service, is substantially same as the transmission of messages between the mobile host 146 and the visitor migration communication control device 109, which is conducted when the mobile host 146 migrates to the network B.

[communication between mobile host 146 attached to network C and stationary host 151]

Transmission of the data packet from the stationary host 151 to the mobile host 146 when the mobile host is attached to the network C is described with referring to FIG. 38-41, which are relevant for FIG. 26-29.

The transmission is substantially same as the transmission between the stationary host 151 and the mobile host 146 when the mobile host 146 is attached to the network B, except that the visitor migration communication control device 109 instead of the home migration communication control device 101 is employed.

(1) When the stationary host 151 is not notified that the mobile host 146 has migrated from the network B to the network C, the stationary host 151 generates the encapsulated data packet including the noncapsulated data packet, which is destined for the home address  $\alpha$ , and the packet transfer message 156; then transmits it to the temporary address  $\beta$ . This is substantially the same as (5) in the communication between the stationary host 151 and the mobile host 146 attached the network B.

The data packet transmitted by the stationary host is not received by the mobile host 146 since the mobile host is not attached to the network B. The data packet is received by the packet monitoring unit 106 in the visitor migration communication control device 109 since the visitor mobile host list hold list unit thereof holds the temporary address  $\beta$  besides the temporary address  $\gamma$ .

(2) The visitor migration communication control device 109 transmits to the temporary address  $\gamma$  of the mobile host 146 the data packet including the packet transfer message 157, which is substantially same as (2) in the communication between the stationary host 151 and the mobile host 146 on the network B except a difference described hereunder.

The home mobile host migration communi-

cation control device 101 receives the noncapsulated data packet 152 and generates an encapsulated data packet comprising the received non-capsulated data packet 152 and the packet transfer message 153. On the other hand, the visitor migration communication control device 109 receives the encapsulated data packet comprising the packet transfer message 156 and the packet transfer unit 111 converts the data packet by changing the destination address from the temporary address  $\beta$  into the temporary address  $\gamma$  as well as converting the packet transfer message 156 into the packet transfer message 157, whose value on the counter is incremented by 1.

(3)-(5) The visitor migration communication control device 109, the stationary host 151, and the mobile host 146 on the network C operate substantially same as the home migration communication control device 101, the stationary host 151, and the mobile host 146 on the network B, which is described the above in (3)-(5); thereby the mobile host transfer message 158 and the response message 158R are transmitted, and the data packet including the packet transfer message 160 is transmitted by the stationary host 151 to the mobile host 146 attached to the network C.

If the stationary host 151 does not transmit any data packet to the mobile host 146, which is attached to the network B, the stationary host is not notified of either the temporary address  $\beta$  or the temporary address  $\gamma$ ; therefore, the stationary host 151 transmits the data packet to the home address  $\alpha$  even when the mobile host 146 has migrated from the network B to the network C. When this occurs, the home migration communication control device 101, as does the visitor migration communication device 109, transfers the data packet from the home address  $\alpha$  to the temporary address  $\gamma$ ; then notifies the stationary host 151 of the updated temporary address  $\gamma$  of the mobile host 146 so that the stationary host 151 will be able to directly transmit the data packet, which comprises the packet transfer message, to the mobile host 146 attached to the network C.

Further, when the mobile host 146 migrates to the network, to which the visitor migration communication control device is attached to provide the packet transfer service, the stationary host 151 may transmit the data packet destined for any of the addresses  $\alpha$ ,  $\beta$ , or  $\gamma$ . When the data packet is transmitted to the home address  $\alpha$  or the temporary address  $\gamma$ , the home migration communication control device 101 or the visitor migration communication control device 109', which is notified of the updated temporary address of the mobile host 146, transfers the data packet to the updated temporary address; then it notifies the stationary host 151 of the updated temporary address of the mobile host.

When the data packet is transmitted to the temporary address  $\beta$  of the mobile host 146, the visitor migration communication control device 109 receives it. Since the device 109 is notified of only the temporary address  $\gamma$ , it transmits the data packet comprising the packet transfer message to the temporary address  $\gamma$  as well as transmits the mobile host transfer message to notify the stationary host 151 of the temporary address  $\gamma$ . The visitor migration communication control device 109' receives the data packet comprising the packet transfer message, which is destined for the temporary address  $\gamma$ , and transmits it to the updated temporary address of the mobile host 146; then transmits the mobile host transfer message to notify the stationary host 151 of the updated temporary address. Also the visitor migration communication control device 109' obtains the address of the visitor migration communication control device 109 from the source address of data packet transmitted thereby, and transmits the mobile host transfer message to the device 109. Thus, the visitor migration communication control device 109' obtains the updated temporary address of the mobile host 146, and transfers the data packet to the mobile host 146 as well as notifies stationary host 151 of the obtained updated temporary address.

[communication operation 2]

Another example of the communication operation is described hereunder. In the communication operation 2 the visitor migration communication control device 109 does not provide the packet transfer service when the mobile host 146 migrates from the network A to the network B, further from the network B to the network C.

As shown in FIG. 42, when the device 109 does not provide the packet transfer service, the autonomous packet transfer support check message 181, transmitted by the mobile host 146 which has migrated from the network A to the network B, is responded with the response message 181R where the autonomous flag F in the autonomous flag field 135 indicates 0. Thereby, the autonomous flag field 135 in the address post message 182, which is transmitted by the mobile host 146 to the home migration communication control device 101, obtains the value 0, and the value 0 is held in the home mobile host list hold unit 102 in the device 101. The mobile host 146 does not transmit the mobile host visit message to the visitor migration communication control device 109.

As shown in FIG. 43, receiving from the stationary host 151 the noncapsulated data packet 183, which is destined for the home address  $\alpha$ , the home migration communication control device generates the encapsulated data packet comprising the received noncapsulated data packet 183 and the packet transfer message 184, and transmits it to the tem-

porary address  $\beta$ , as is in the communication operation 1.

However, recognizing the value 0 on the autonomous flag F, which is held in the home mobile host list hold unit 102, the device 101 does not transmit to the stationary host 151 the mobile host transfer message including the temporary address  $\beta$ . Therefore, every data packet transmitted by the stationary host 151 is destined for the home address  $\alpha$ , and it is transferred to the mobile host 146 by the home migration communication control device 101. Thus, the stationary host 151 is not notified of the temporary address  $\beta$  since the data packet transmitted to the address other than the home address  $\alpha$  is not transferred by the device 109; therefore it is not received by the mobile host 146 when it departs the network B to migrate to the network C.

When the visitor migration communication control device 109', which is attached to the network, provides the packet transfer service, the home migration communication control device 101 notifies the stationary host 151 of the temporary address  $\gamma$  when it transmits the noncapsulated data to the home address  $\alpha$ , so that the stationary host 151 is able to directly transmit the data packet comprising the noncapsulated data packet and the packet transfer message to the mobile host 146 on the network C.

When the visitor migration communication control device 109 does not provide the packet transfer service, the home migration communication control device 101 does not necessarily notify the device 109 of the temporary address  $\gamma$  of the mobile host 146 assigned when it has migrated from the network B to the network C. However, the construction of the device 101 will be simplified if it conducts the same operation either or not the packet transfer service is provided since the visitor migration communication control device 109 ignores the mobile host transfer message.

Also the device 109 may respond to the autonomous packet transfer support check message 181 only when it provides the data packet transfer service; therefore, the presence or absence of the response message 181R indicates to the mobile host 146 whether or not the data packet transfer service is provided. In the above operation the value 0 of the autonomous F also indicates that the packet transfer service is not provided, whereas absence of the response message to the message 181 can indicate the absence of the packet transfer service, which will simplify construction of mobile host 146.

[communication operation 3]

The final example of the communication operation is described hereunder. In the communication operation 3 the visitor migration communication control device 109' does not provide the packet transfer service while the visitor migration communication control

device 109 does.

As shown in FIG. 44, when the packet transfer service is not provided by the visitor migration communication control device 109', the mobile host 146 transmits to the home migration communication control device 101 the address post message 182' where the value 0 is set at the autonomous flag F. Then, the home migration communication control device 101 transmits to the device 109 the mobile host transfer message 185 by setting the value 0 at the autonomous flag F.

When detecting the value 0 at the autonomous flag F, the visitor migration communication control device 109 ceases to provide the packet transfer service.

As shown in FIG. 45, even after cease of the data packet transfer service, the stationary host 151 may transmit to the temporary address the data packet comprising the noncapsulated data packet and the packet transfer message 186.

When this happens, the visitor migration communication control device 109 obtains the noncapsulated data packet 187 from the received encapsulated data packet and transmits it to its destination address, the home address  $\alpha$ . The noncapsulated data packet 187 is then received by the home migration communication control device 101, which is attached to the network A. Finally, the home migration communication control device 101 transfers the noncapsulated data packet 187 together with the packet transfer message 188 to the temporary address  $\gamma$  of mobile host 146, which is attached to the network C.

The visitor migration communication control device 109 notifies the stationary host 151 that the mobile host 146 is attached to the network A instead of the network C by sending the mobile host transfer message 189 where the home address  $\alpha$  is set in the temporary address field 139. Then, the stationary host 151 transmits the noncapsulated data packet 187 to the home address  $\alpha$ , and it is transferred by the home migration communication control device 101, which is employed to take the place of the visitor migration communication control device 109. As another option, the device 109 may send the mobile host transfer message 189 where the invalid address is set, such as the address where every bit is 1. Then, the home migration communication control device 101 may notify the stationary host 151 of the home address  $\alpha$  in accordance with the address inquiry obtained from the stationary host 151.

The operation described the above will be employed when the visitor migration communication control device 109 ceases to provide the packet transfer service operation regardless whether or not the device 109' provides the packet transfer service.

On the other hand, the visitor migration communication device 109 may restart the packet transfer service even when the device 109' ceases to provide



the service.

In this case, the home migration communication control device 101 needs to provide the visitor migration communication control device 109 with the updated temporary address at every migration of the mobile host 146 unless the mobile host migrates to the network to which another visitor migration communication control device is attached and provides the packet transfer service. To realized it, for example, when the value of the autonomous flag F in the address post message is 0 to indicate that the device 109' does not provide the packet transfer service, the broadcast address Bba as the destination address of the mobile host transfer message, which is transmitted to the device 109, will not be renewed.

Additionally, the broadcast address as the destination address of the data packet, which is transmitted by the mobile host 146, can be replaced with the address Ha, Va, Va', each of which is unique to each device. The address unique to each device will be obtained by detecting the source address of the data packet received from each device, or by employing a so called name service.

Also in the second embodiment, the home migration communication control device 101 detects whether or not the mobile host 146 is attached to the same network from what is held as the temporary address in the address hold unit; to be precise, whether or not the home address  $\alpha$  is held as the temporary address. However, this can also be detected by knowing in which table the temporary address is held. For example, when the device 101 and the mobile host 146 are attached to the same network, the first table holds the addresses, such as the home address  $\alpha$ ; whereas, the second table holds the addresses when the device 101 and the mobile host 146 are attached to the different network from each other. Value of the autonomous flag F, 0 or 1, can also be utilized in the same way.

Further, the home migration communication control device 101 and the visitor migration communication control device 109, 109' may be employed as a host such as the mobile host 146 or the stationary host 151.

Finally, the home migration communication control device 101, the visitor migration communication control device 109, the mobile host 146, and the stationary host 156 may be constructed identically and can be replaced with each other.

Although in the embodiment the application unit 124 starts its operation before being notified of updated temporary address  $\beta$ ; therefore it always transmits the data packet to the home address  $\alpha$  of the mobile host 146, it can transmit the data to the temporary address  $\beta$  if it starts its operation after obtaining the temporary address  $\beta$ .

Although the present invention has been fully described by way of examples with reference to the ac-

companying drawings, it is to be noted that various changes and modifications will be apparent to those skilled in the art. Therefore, unless otherwise such changes and modifications depart from the scope of the present invention, they should be constructed as being included therein.

## Claims

1. A migration communication control device constructed to control a communication between a mobile node and a partner node, the mobile node migrating across networks and obtaining an address assigned on each network while the partner node being a communication partner of the mobile node, comprising a first migration control unit, a second migration control unit, a third migration control unit, the second migration control unit being placed on the mobile node and the third migration control unit being placed on the partner node,

wherein the first migration control unit comprises:

packet transfer means for receiving a packet which was destined for an outdated address of the mobile node, the outdated address assigned when the mobile node migrated to a network to which the first migration control unit is attached, generating a conversion packet which holds an updated address instead of the outdated address, and transmitting the conversion packet; and

address post means for transmitting an address post message which indicates the updated address of the mobile node to the third migration control unit, the third migration control unit transmitting the packet received by the packet transfer means, and

the second migration control unit comprises:

migration post means for transmitting to the first migration control unit a migration post message which indicates the updated address of the mobile node when the mobile node migrates to another network; and

packet resumption means for receiving the conversion packet from both the first migration control unit and the third migration control unit and resuming an original packet from the conversion packet, and

the third migration control unit comprises:

packet conversion means for converting a destination address of a packet, the packet to be transmitted to the mobile node, into the updated address indicated by the address post message, the address post message sent by the first migration control unit, and transmitting it to the mobile



node.

2. The migration communication control device of Claim 1, wherein the migration post means in the second migration control unit transmits an identification key included in the migration post message, the identification key being employed to identify the mobile node.
3. The migration communication control device of Claim 2, wherein the identification key is an address of the mobile node assigned at one network before the network to which the mobile node is currently attached.
4. The migration communication control device of Claim 2, wherein the identification key is an address of the mobile node assigned before its initial migration.
5. The migration communication control device of Claim 1; wherein the second migration control unit is constructed to transmit to the third migration control unit the packet which has the same format as the resumed packet.
6. The migration communication control device of Claim 1, wherein the first migration control unit further comprises:
  - address hold means for holding the outdated address and the updated address by corresponding them with each other; and
  - address comparison means for comparing the destination address of the received packet with the outdated address, wherein
  - the packet transfer means generates the conversion packet and transmits it when the address comparison means detects that the destination address of the received packet coincides with the outdated address.
7. The migration communication control device of Claim 1, wherein the first migration control unit further comprises:
  - address hold means for holding the outdated address and the updated address by corresponding them with each other; and
  - address comparison means for comparing the destination address of the packet received by the packet transfer means with the outdated address, wherein
  - the address post means transmits the address post message which indicates the updated address of the mobile node to the third migration control unit, the third migration control unit transmitting the packet received by the packet transfer means, when the address comparison means detects that the destination address of the packet

coincides with the outdated address.

8. The migration communication control device of Claim 1, wherein the second migration control unit further comprises:
  - address hold means for holding the outdated address and the updated address by corresponding them with each other; and
  - address comparison means for comparing the updated address with the destination address of the packet received from one of the first migration control unit and the third migration control unit, wherein
  - the packet resumption means resumes the original packet from the conversion packet when the address comparison means detects that the updated address coincides with the destination address of the packet received from one of the first migration control unit and the third migration control unit.
9. The migration communication control device of Claim 1, wherein the third migration control unit further comprises:
  - address hold means for holding the outdated address and the updated address of the mobile node by corresponding them with each other; and
  - address comparison means for comparing the outdated address in the address hold means with the destination address of the packet to be transmitted to the mobile node, wherein
  - the packet conversion means converts the destination address of the packet to be transmitted to the mobile node into the updated address which corresponds to the outdated address in the address hold means when the address comparison means detects the outdated address in the address hold means coincides with the destination address of the packet.
10. The migration communication control device of Claim 1, wherein there are a plurality of the first migration control units, and the second migration control unit transmits the migration post message to at least one of the first migration control units.
11. The migration communication control device of Claim 10, wherein the migration post means in the second migration control unit transmits the migration post message to the first migration control unit which is attached to the network to which the mobile node was attached before its migration,
  - each of the first migration control units has migration post means for transmitting to one of the other first migration control units a migration post message to post the same address as the

updated address indicated by the migration post message received from the second migration control unit, and

each of the first migration control units has migration post means for transmitting a migration post message from one of the other first migration control units to another first migration control unit to post the same address as the updated address indicated by the received migration post message.

12. The migration communication control device of Claim 11, wherein each of the first migration control units and the second migration control unit further comprise pointer hold means for holding pointers related to the first migration control unit to which the migration post message is transmitted, and wherein

the migration post means in each of the first migration control units and the migration post means in the second migration control unit transmit the migration post message to each of the addresses related to each of the pointers.

13. The migration communication control device of Claim 12, wherein each of the pointers is a broadcast address of the network to which one of the first migration control units is attached.

14. The migration communication control device of Claim 12, wherein each of the pointers is an address which is assigned to one of the first migration control units uniquely.

15. The migration communication control device of claim 12, wherein each of the pointers is the address of the mobile node which is assigned when the mobile node is attached to the same network as is the first migration control unit, and

the migration post means in the first migration control unit and the migration post means in the second migration control unit obtain the broadcast address of the network to which each of the first migration control units is attached with referring to the address of the mobile node, and transmits the migration post message to the obtained broadcast address.

16. The migration communication control device of Claim 12, wherein the pointer hold means in the second migration control unit holds a pointer related to a first migration control unit for the latest migration, which is the first migration control unit being attached to one network before the network to which the mobile node is currently attached, and

the pointer hold means in the first migration control unit holds a pointer related to another

first migration control unit attached to the same network as was the mobile node attached before migrating to the network to which the first migration control unit is attached.

17. The migration communication control device of Claim 12, wherein the second migration control unit further transmits to the first migration control unit the pointer by sending thereto the migration post message, the pointer to be held by the first migration control unit.

18. The migration communication control device of Claim 17, wherein the first migration control unit stores into the pointer hold means the pointer when it receives from the second migration control unit the migration post message by corresponding the pointer with the updated address indicated by the received migration post message.

19. The migration communication control device of Claim 11, wherein each of the first migration control units further comprises:

address hold means for holding the outdated address and the updated address by corresponding them with each other, wherein

migration post message means stores into the address hold means the outdated address and the updated address by corresponding them with each other when it receives from the second migration control unit the migration post message, while converts the updated address in the address hold means into the updated address indicated by the migration post message when it receives from the first migration control unit the migration post message and the outdated address indicated by the migration post message coincides with one of the updated addresses in the address hold means.

20. The migration communication control device of Claim 1, wherein the first migration control unit is placed on a gateway, which connects networks.

21. The migration communication control device of Claim 1, wherein the first migration control unit is placed on the network as an individual node.

22. The migration communication control device of Claim 10, wherein the migration post means in the second migration control unit transmits the migration post message to a home migration control unit, the home migration control unit being the first migration control unit which is attached to a network where the mobile node left for its initial migration, and

the home migration control unit further

comprises home migration post means for transmitting a migration post message to a first migration control unit for the latest migration, the first migration control unit for the latest migration being the first migration control unit which is attached to the network where the mobile node left for the latest migration, to post the same updated address as is indicated by the migration post message received from the second migration control unit.

23. The migration communication control device of Claim 22, wherein the first migration control unit further comprises migration post means for transmitting the migration post message indicating the updated address of the mobile node to one of the other first migration control units when the conversion packet destined for the outdated address of the mobile node was sent therefrom to the first migration control unit.

24. The migration communication control device of Claim 22, wherein the migration post means in the second migration control unit transmits to the home migration control unit the migration post message where a home address and the updated address are corresponded with each other, the home address assigned when the mobile node is attached to the same network as is the home migration control unit,

and each of the packet transfer means and the address post means in the home migration control unit transmits the conversion packet and the address post message respectively with referring to the above home address and the updated address.

25. The migration communication control device of Claim 24, wherein the second migration control unit further comprises an outdated address post means for transmitting to the first migration control unit for the latest migration an outdated address post message where the outdated address and the home address are corresponded with each other, the outdated address being assigned to the mobile node before the latest migration,

the home migration post means in the home migration control unit transmits to the said first migration control unit for the latest migration the migration post message where the above home address and the updated address are corresponded with each other, and

the packet transfer means and the address post means in the first migration control unit for the latest migration transmit the conversion packet and the address post message respectively in accordance with the outdated address and the updated address, the outdated ad-

dress and the updated address being corresponded with each other via the home address.

26. The migration communication control device of the Claim 25, wherein the outdated address post means in the second migration control unit transmits the above outdated address post message at a migration of the mobile node preceding the latest migration, and

each of the migration post means in the second migration control unit and the home migration post means in the home migration control unit transmits the above migration post message at the latest migration of the mobile node.

27. The migration communication control device of Claim 22, wherein the second migration control unit further comprises home migration control unit pointer hold means for holding a pointer related to the home migration control unit,

the migration post means in the second migration control unit transmits the migration post message to the address related to the pointer,

the home migration control unit further comprises pointer hold means for the latest migration for holding a pointer related to the first migration control unit for the latest migration, and

the home migration post means in the home migration control unit transmits the migration post message to the address related to the pointer.

28. The migration communication control device of Claim 27, wherein each of the above pointers is the broadcast address of the network to which each of the first migration control units is attached.

29. The migration communication control device of Claim 27, wherein each of the above pointers is the address assigned to each of the first migration control units uniquely.

30. The migration communication control device of Claim 27, wherein the second migration control unit further comprises pointer obtainment means for requesting to the first migration control unit for the latest migration the pointer related to the first migration control unit for the latest migration, and the migration post means in the second migration control unit posts the obtained pointer to the home migration control unit together with the updated address by sending thereto the migration post message.

31. The migration communication control device of Claim 30, wherein the migration post means in the second migration control unit posts to the

home migration control unit the pointer at the migration of the mobile node preceding the latest migration, while the migration post means posts the above updated address at the latest migration of the mobile node.

32. The migration communication control device of Claim 22, wherein the first migration control unit further comprises address post suppressing means for suppressing transmission of the address post message from the address post means to the third migration control unit, and

the address post suppressing means suppresses transmission of the address post message when none of the first migration control units is attached to the same network as is the mobile node.

33. The migration communication control device of Claim 32, wherein the second migration control unit further comprises detect means for detecting whether or not the first migration control unit is attached to the network to which the mobile node migrates,

the migration post means in the second migration control unit transmits to the home migration control unit the migration post message which includes the detecting result of the above detect means together with the updated address,

the home migration post means in the home migration control unit transmits to the first migration control unit for the latest migration the migration post message which includes the detecting result of the above detect means together with the updated address, and

the address post suppressing means in each of the home migration control unit and the first migration control unit for the latest migration suppress the transmission of the address post message in accordance with the detecting result of the above detect means.

34. The migration communication control device of Claim 22, wherein the first migration control unit further comprises packet transfer suppressing means for suppressing transfer of the packet conducted by the packet transfer means.

35. The migration communication control device of Claim 34, wherein the first migration control unit further comprises address post suppressing means for suppressing transmission of the address post message from the address post means to the third migration control unit, and the address post suppressing means in the first migration control unit being attached to a network to which the mobile node is not attached, suppresses the transmission of the address post message

when the packet transfer suppressing means in the first migration control unit for the latest migration suppresses transfer of the packet.

36. The migration communication control device of Claim 35, wherein the second migration control unit further comprises detect means for detecting whether or not the packet transfer suppressing means in the first migration control means suppresses the transfer of the packet, the first migration control means being attached to the network to which the mobile node migrates, and

the migration post means in the second migration control unit transmits to the home migration control unit the migration post message which includes the detecting result of the above detect means together with the updated address,

the home migration post means in the home migration control unit transmits to the first migration control unit for the latest migration the migration post message which includes the detecting result of the detect means together with the updated address, and

the address post suppressing means in each of the home migration control unit and the first migration control unit for the latest migration suppresses the transmission of the address post message in accordance with the detecting result of the above detect means.

37. The communication control device of Claim 36, wherein the packet transfer suppressing means in the first migration control unit for the latest migration suppresses the transfer of the packet conducted by the packet transfer means, when the packet transfer suppressing means in the first migration control unit being attached to the network to which the mobile node migrates suppresses the transfer of the packet.

38. A packet transfer migration control unit in a migration communication control device, the migration communication control device being constructed to control a communication between a mobile node and a partner node, the mobile node migrating across networks and obtaining an address assigned on each network while the partner node being a communication partner of the mobile node, comprising:

packet transfer means for receiving a packet which was transmitted by the partner node to an outdated address of the mobile node, the outdated address being assigned when the mobile node migrated to a network to which the packet transfer migration control unit is attached, generating a conversion packet which holds an updated address instead of the outdated address, and transmitting the conversion packet;

and

address post means for transmitting an address post message which indicates the updated address of the mobile node to the partner node, the partner node transmitting the packet received by the packet transfer means.

5

39. A mobile node migration control unit in a migration communication control device, the migration communication control device being constructed to control a communication between a mobile node which migrates across networks and obtains an address assigned on each network and a partner node which is a communication partner of the mobile node, being placed on the mobile node and comprising:

10

migration post means for transmitting to a packet transfer migration control unit a migration post message which indicates an updated address of the mobile node when the mobile node migrates to another network, the packet transfer migration control unit for receiving a packet which was transmitted by the partner node to an outdated address of the mobile node, the outdated address assigned when the mobile node migrated to a network to which the migration control unit for packet transfer is attached, generating a conversion packet which holds the updated address instead of the outdated address, and transmitting the conversion packet; and

15

20

25

30

packet resumption means for receiving the conversion packet from both the packet transfer migration control unit and the mobile node, and resuming an original packet from the conversion packet.

35

40. A partner node migration control unit in a migration communication control device, the migration communication control device being constructed to control a communication between a mobile node which migrates across networks and obtains an address assigned on each network and a partner node which is a communication partner of the mobile node, being placed on the mobile node and comprising:

40

45

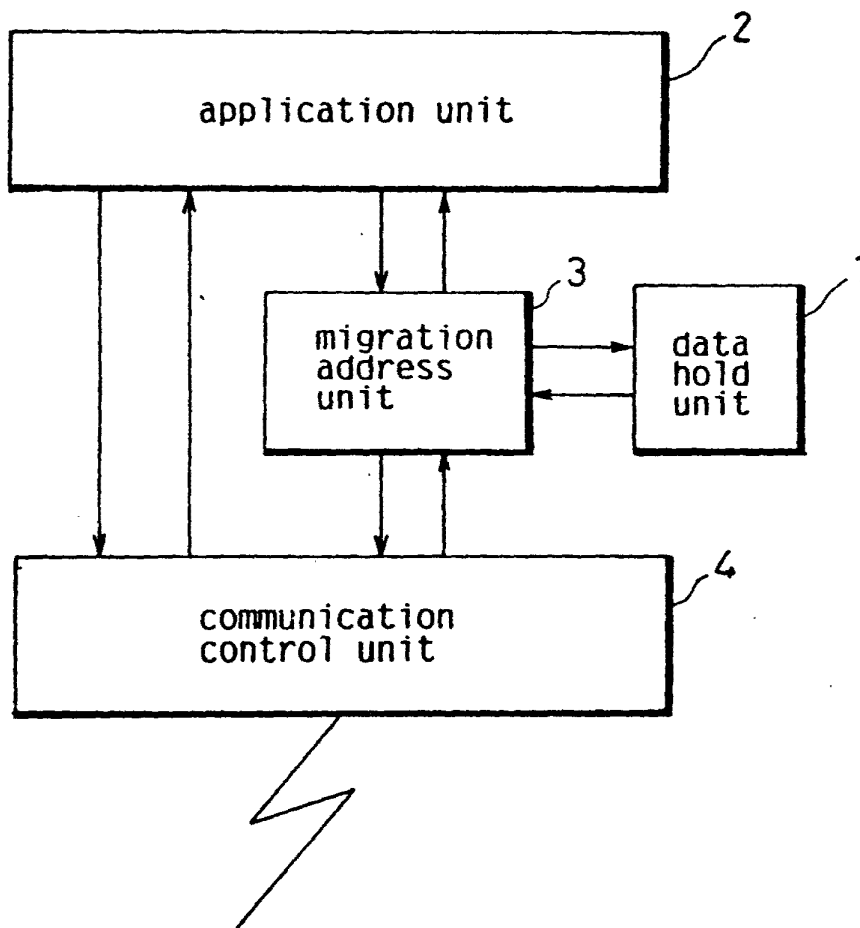
address post message receiving means for receiving an address post message which indicates an updated address of the mobile node from a packet transfer migration control unit, the packet transfer migration control unit transmitting an address post message which indicates the updated address of the mobile node to the partner node; and

50

packet conversion means for converting a destination address of a packet, the packet to be transmitted to the mobile node, into the updated address indicated by the address post message, and transmitting it to the mobile node.

55

FIG. 1



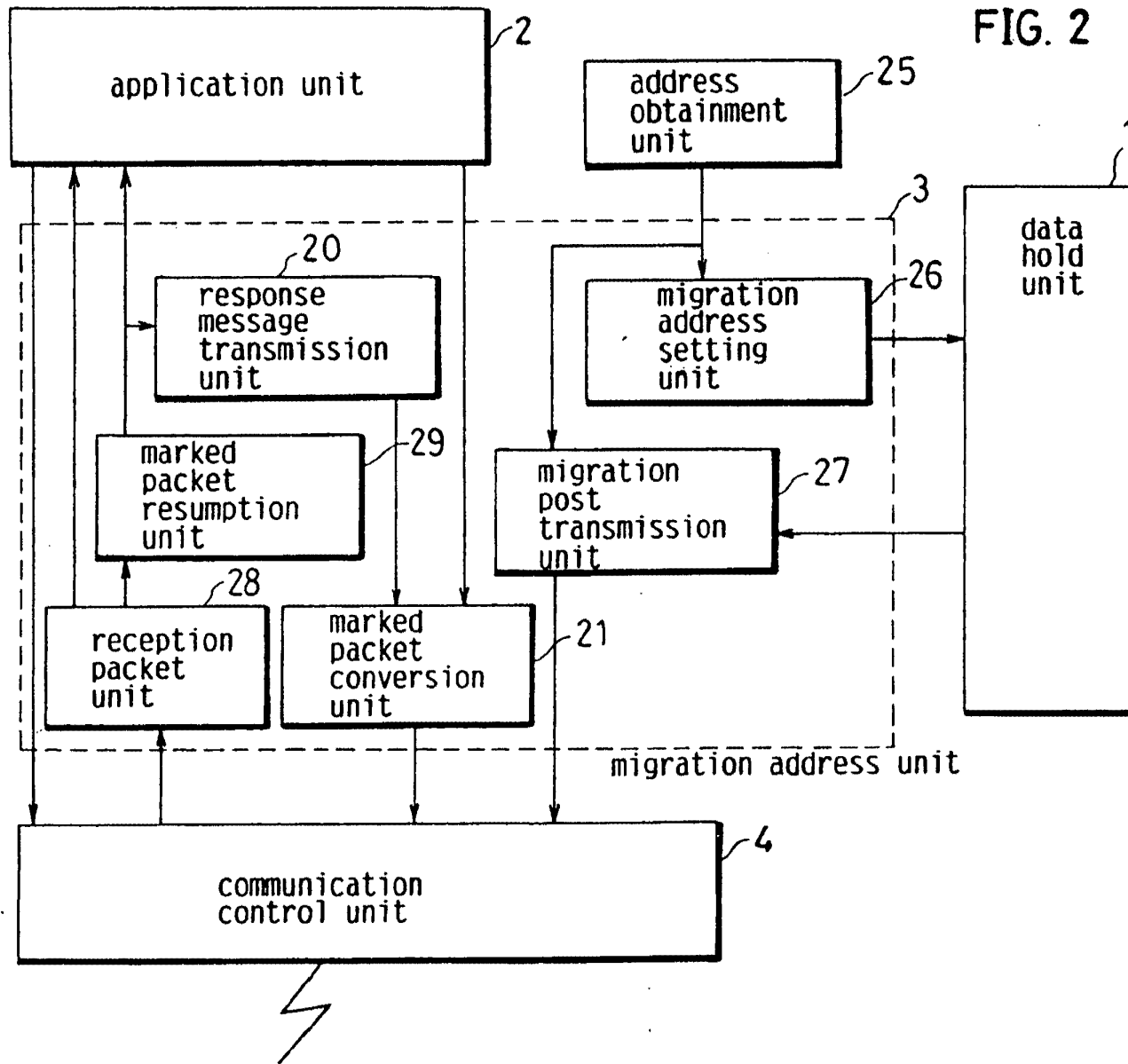


FIG. 2

FIG. 3

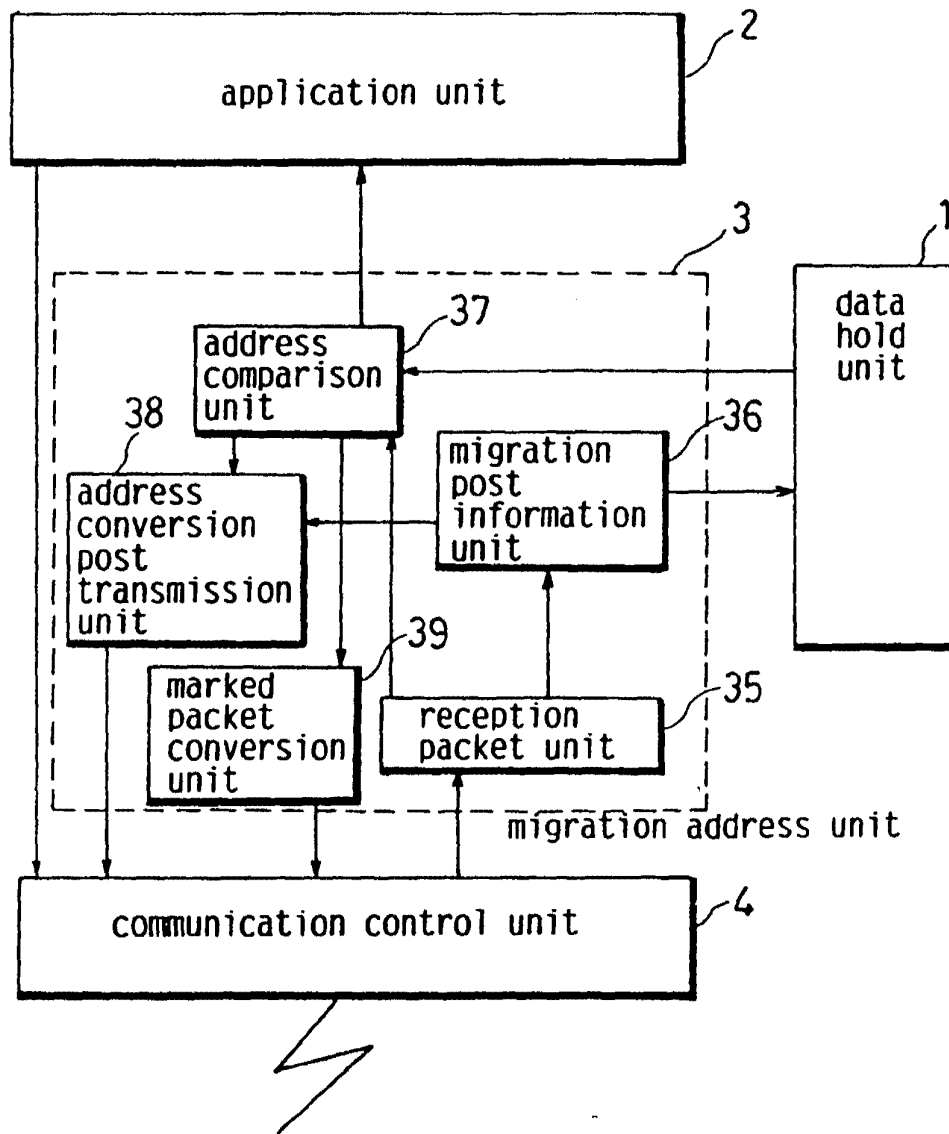
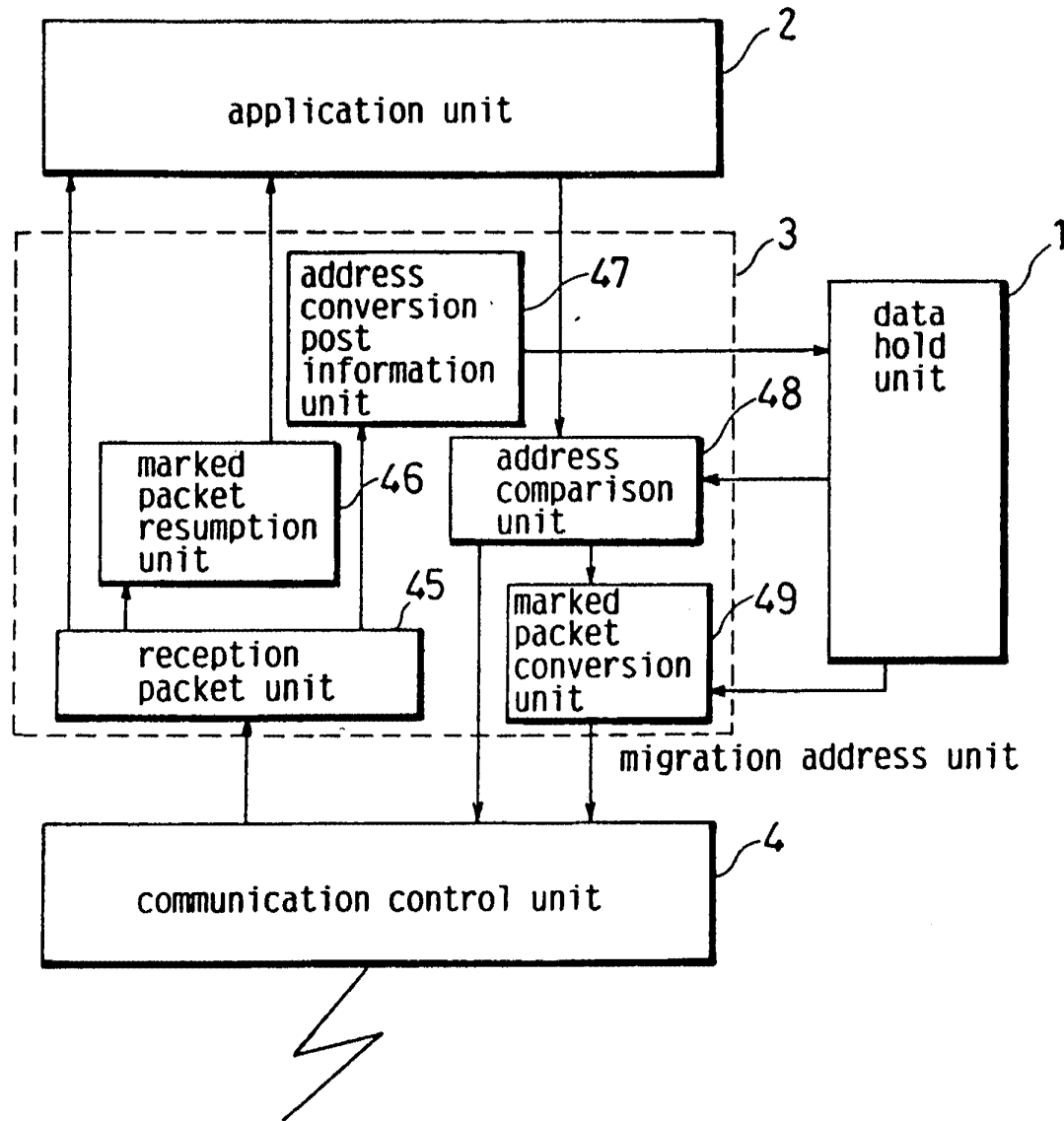




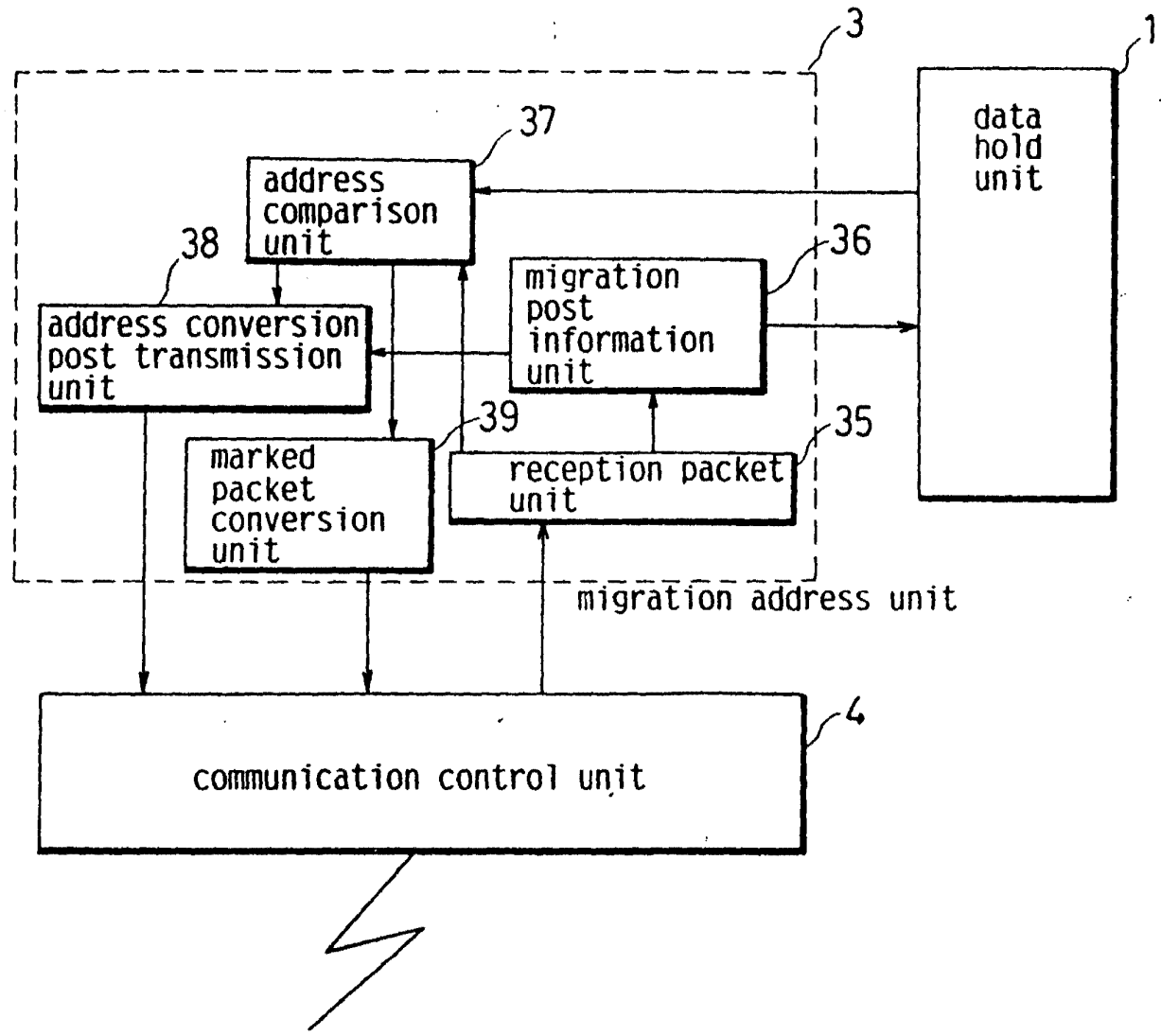
FIG. 4



EP 0 556 012 A2

28

FIG. 5



39

FIG. 6

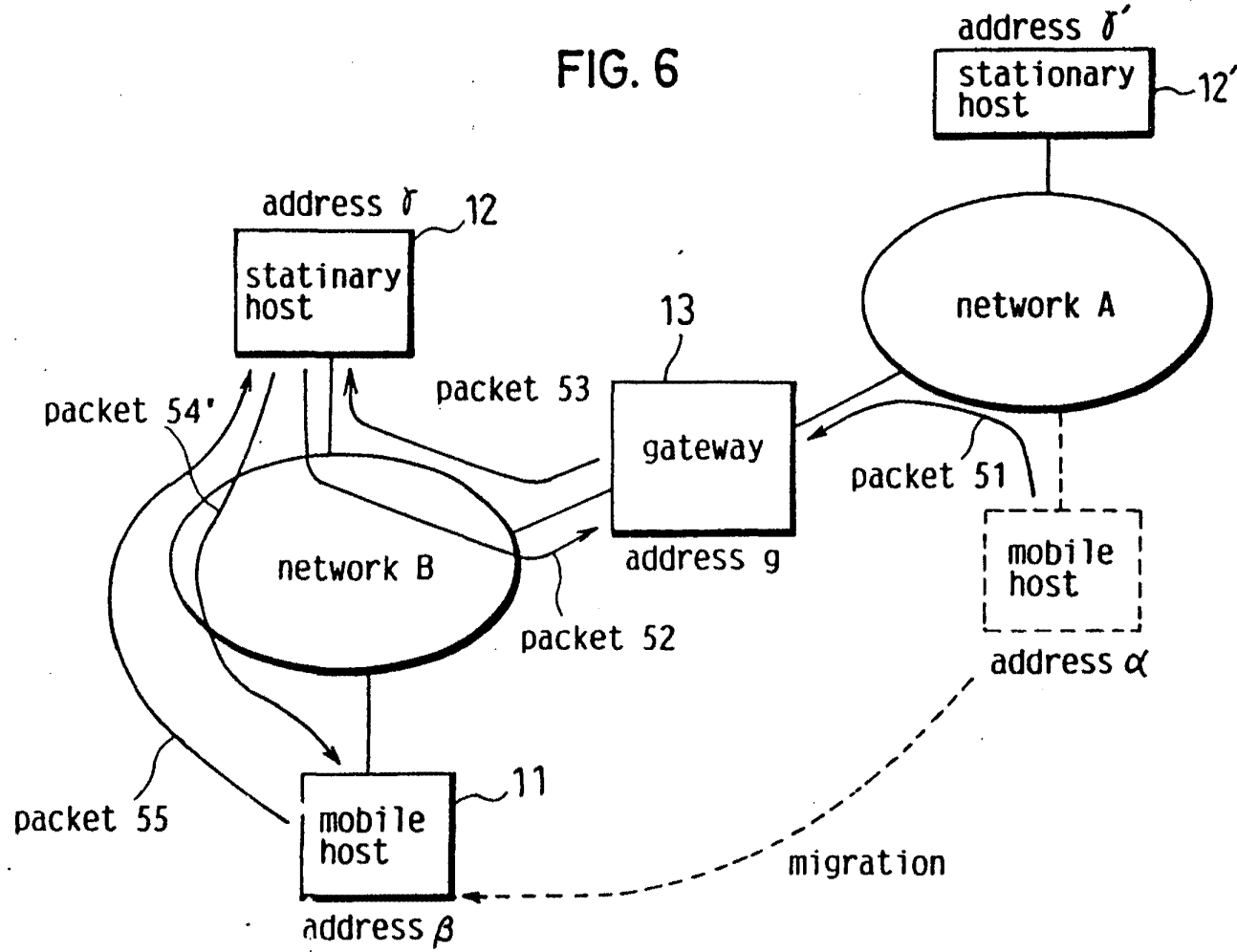


FIG. 7

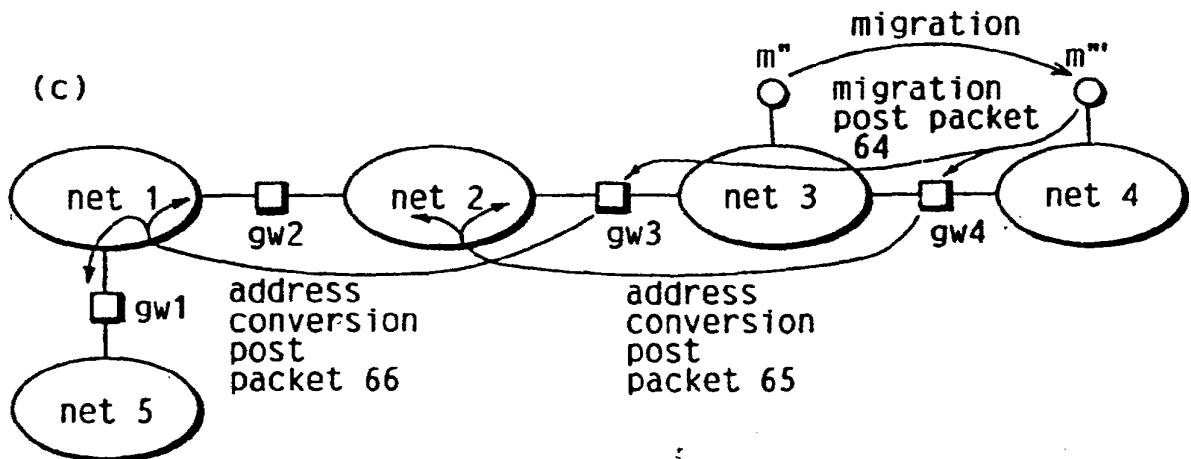
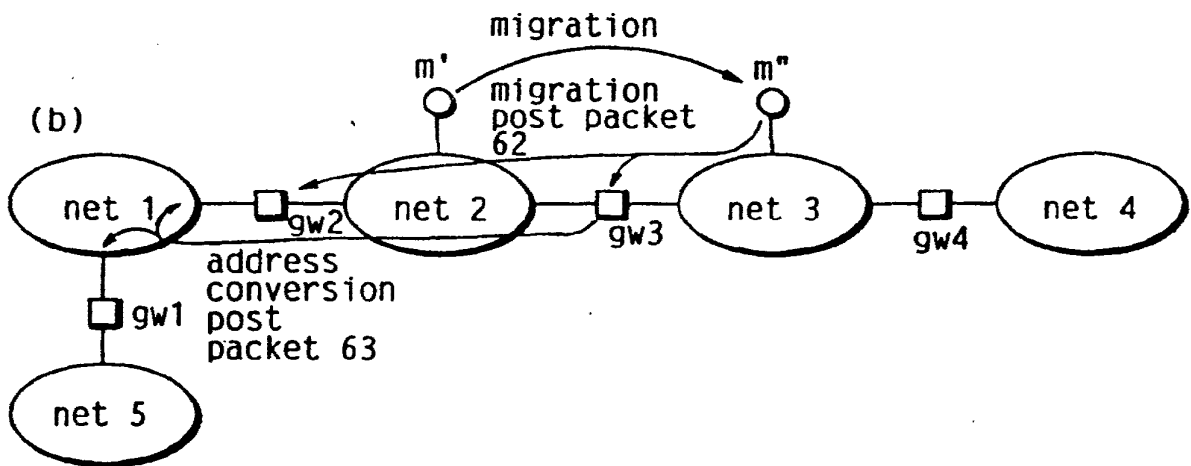
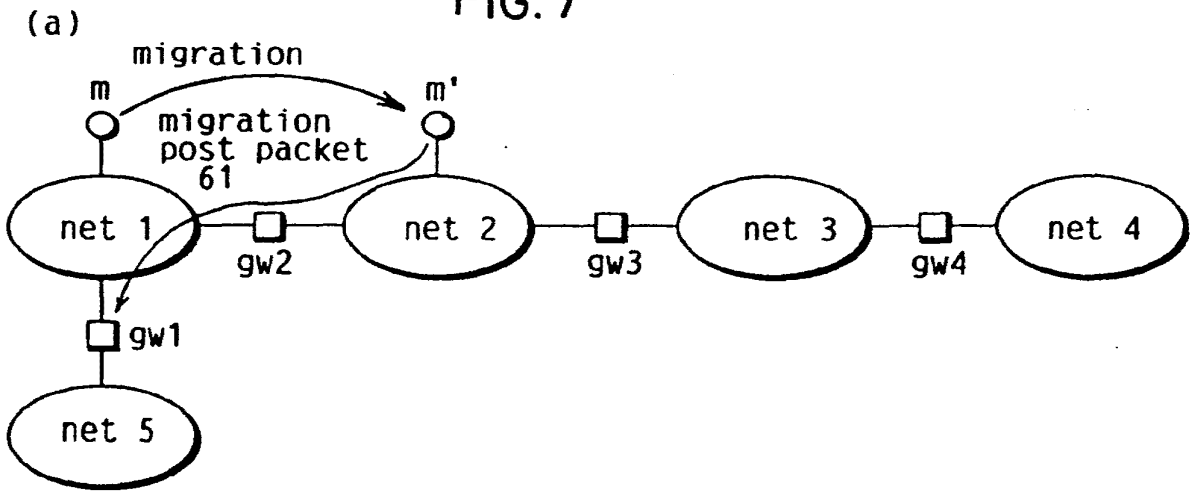


FIG. 8

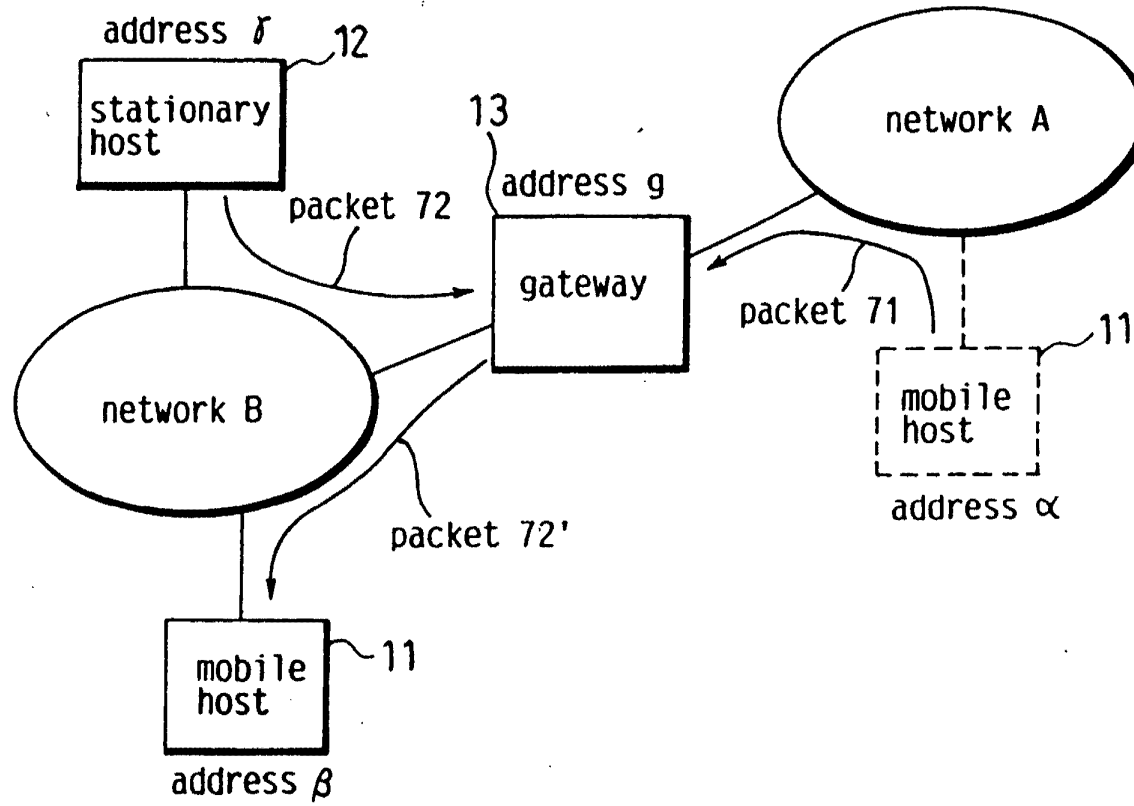


FIG. 9

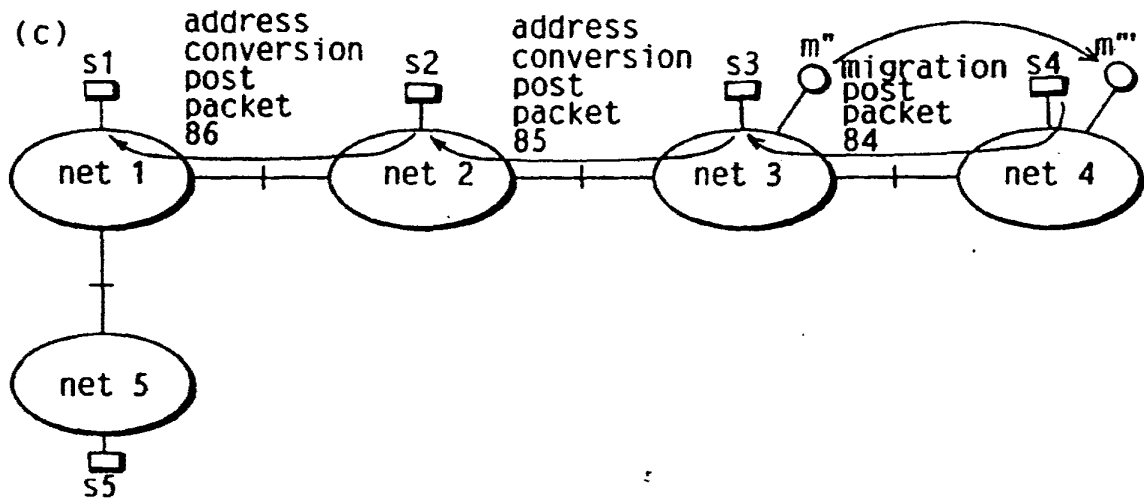
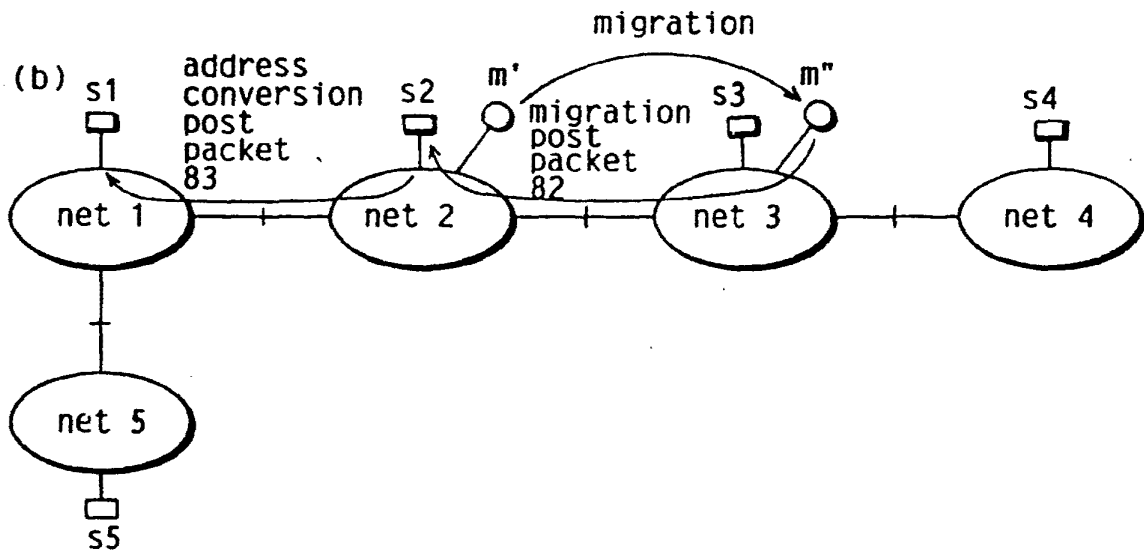
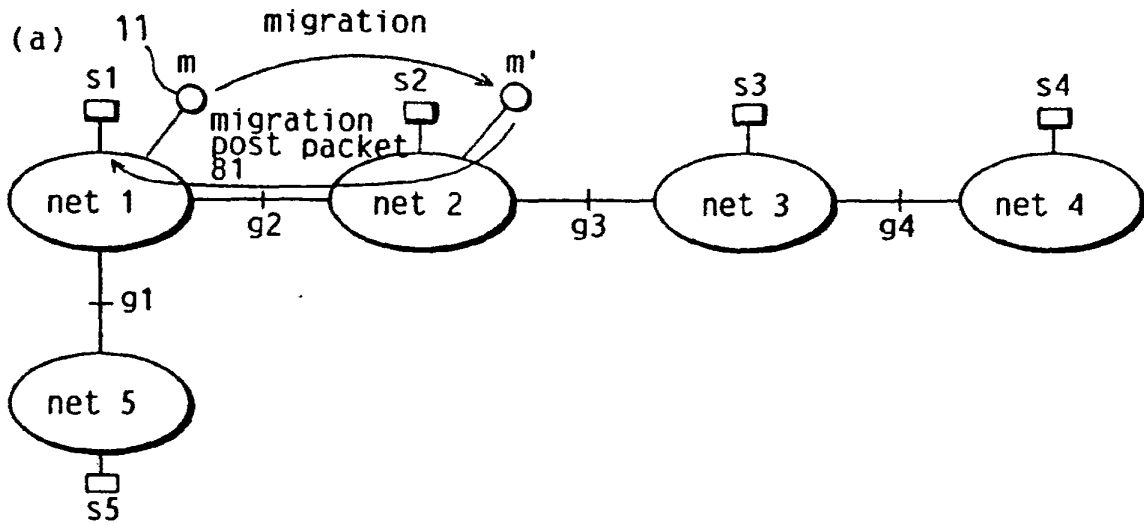


FIG. 10

(a)

address before migration	address after migration
address $\alpha$	address $\beta$

(b)

address before migration	address after migration
address $\alpha$	address $\beta$
address X	address Y



European Patent Office  
Office européen des brevets



Publication number : 0 556 012 A3

12

**EUROPEAN PATENT APPLICATION**

21 Application number : 93300919.3

51 Int. Cl.<sup>5</sup> : H04Q 7/00, H04L 12/56

22 Date of filing : 09.02.93

30 Priority : 10.02.92 JP 23506/92  
16.09.92 JP 246855/92  
10.11.92 JP 299531/92

43 Date of publication of application :  
18.08.93 Bulletin 93/33

84 Designated Contracting States :  
DE FR GB

88 Date of deferred publication of search report :  
03.05.95 Bulletin 95/18

71 Applicant : MATSUSHITA ELECTRIC  
INDUSTRIAL CO., LTD.  
1006, Kadoma  
Kadoma-shi, Osaka-fu 571 (JP)

72 Inventor : Wada, Hiromi  
15-10, Higashigaoka, Uzumasa  
Neyagawa-shi, Osaka 572 (JP)  
Inventor : Yozawa, Takashi  
5-16-19, Shinke, Aoo  
Mino-shi, Osaka 562 (JP)  
Inventor : Ohnishi, Tatsuya  
281-5, Kawahara,  
Aza,  
Sasabe  
Kawanishi-shi, Hyogo 666-01 (JP)

74 Representative : Cummings, Sean Patrick et al  
David Keltie Associates  
Audrey House  
Ely Place  
London EC1N 6SN (GB)

54 Migration communication control device.

57 Disclosed is a migration communication control device constructed to control a continuous communication between a mobile node and a node unaffected the mobile node's migration. The migration communication control device comprises a first migration control unit, a second migration control unit on the mobile node, and a third migration control unit on the partner node. The first migration control unit comprises a packet transfer unit and an address post unit. The packet transfer unit receives a packet which was destined for an outdated address of the mobile node, generates a conversion packet which holds an updated address instead of the outdated address, and then transmits the conversion packet, while an address post unit transmits an address post message which indicates the updated address to the third migration control unit. The second migration control unit comprises a migration post unit and a packet resumption unit. The migration post unit transmits to the first migration control unit a migration post message which indicates the updated address when the mobile node migrates to another network while a packet resumption unit receives the conversion packet from both the first migration control unit and the third migration control unit and resumes an original packet from the conversion packet. The third migration control unit comprises a packet conversion unit which converts a destination address of a packet into the updated address, then transmits it to the mobile node.

EP 0 556 012 A3





European Patent  
Office

EUROPEAN SEARCH REPORT

Application Number

DOCUMENTS CONSIDERED TO BE RELEVANT			EP 93300919.3
Category	Citation of document with indication, where appropriate, of relevant passages	Relevant to claim	CLASSIFICATION OF THE APPLICATION (Int. Cl. 5)
A	<p>DATABASE WPIL, no. 90-311 754, DERWENT PUBLICATIONS LTD., London; &amp; TP-A-99 004 (ANONYMOUS) * Abstract *</p> <p>--</p>	1, 38-40	H 04 Q 7/00 H 04 L 12/56
A	<p>GB - A - 2 236 393 (SHELL INTERNATIONALE RESEARCH MAATSCHAPPIJ B.V.) * Fig. 2A,2B; abstract; claim 1 *</p> <p>--</p>	1, 38-40	
A	<p>WO - A - 86/01 918 (HOLBERG) * Fig. 1,2; abstract; claim 1 *</p> <p>----</p>	1, 38-40	
			<p>TECHNICAL FIELDS SEARCHED (Int. Cl. 5)</p> <p>H 04 Q 7/00 H 04 L 12/00 G 06 F 15/00 G 01 V 1/00</p>
The present search report has been drawn up for all claims			
Place of search VIENNA		Date of completion of the search 03-02-1995	Examiner BERGER
<p>CATEGORY OF CITED DOCUMENTS</p> <p>X : particularly relevant if taken alone Y : particularly relevant if combined with another document of the same category A : technological background O : non-written disclosure P : intermediate document</p>		<p>T : theory or principle underlying the invention E : earlier patent document, but published on, or after the filing date D : document cited in the application L : document cited for other reasons ..... &amp; : member of the same patent family, corresponding document</p>	

EPO FORM 1503 (3.12.1989)

FIG. 11

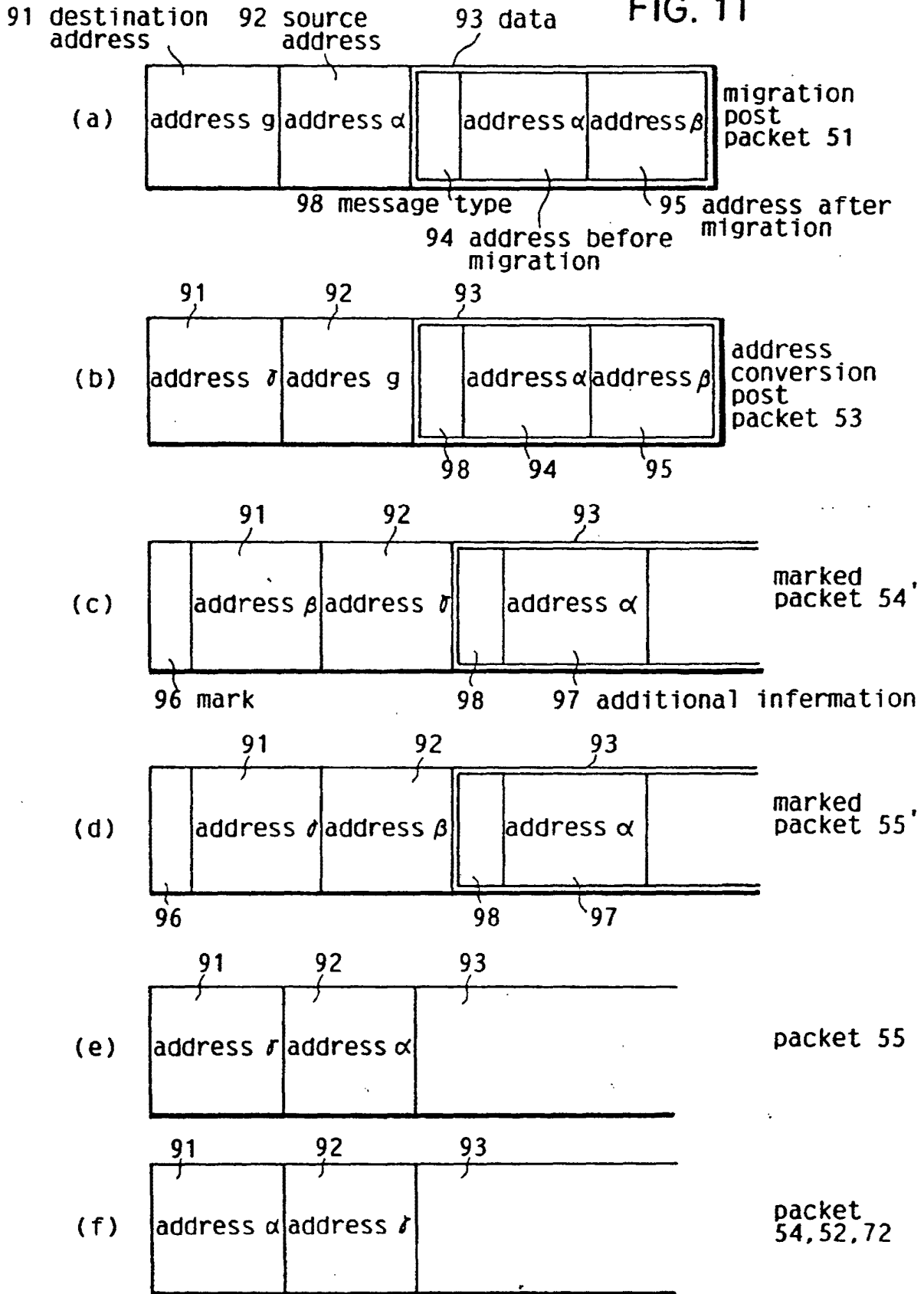
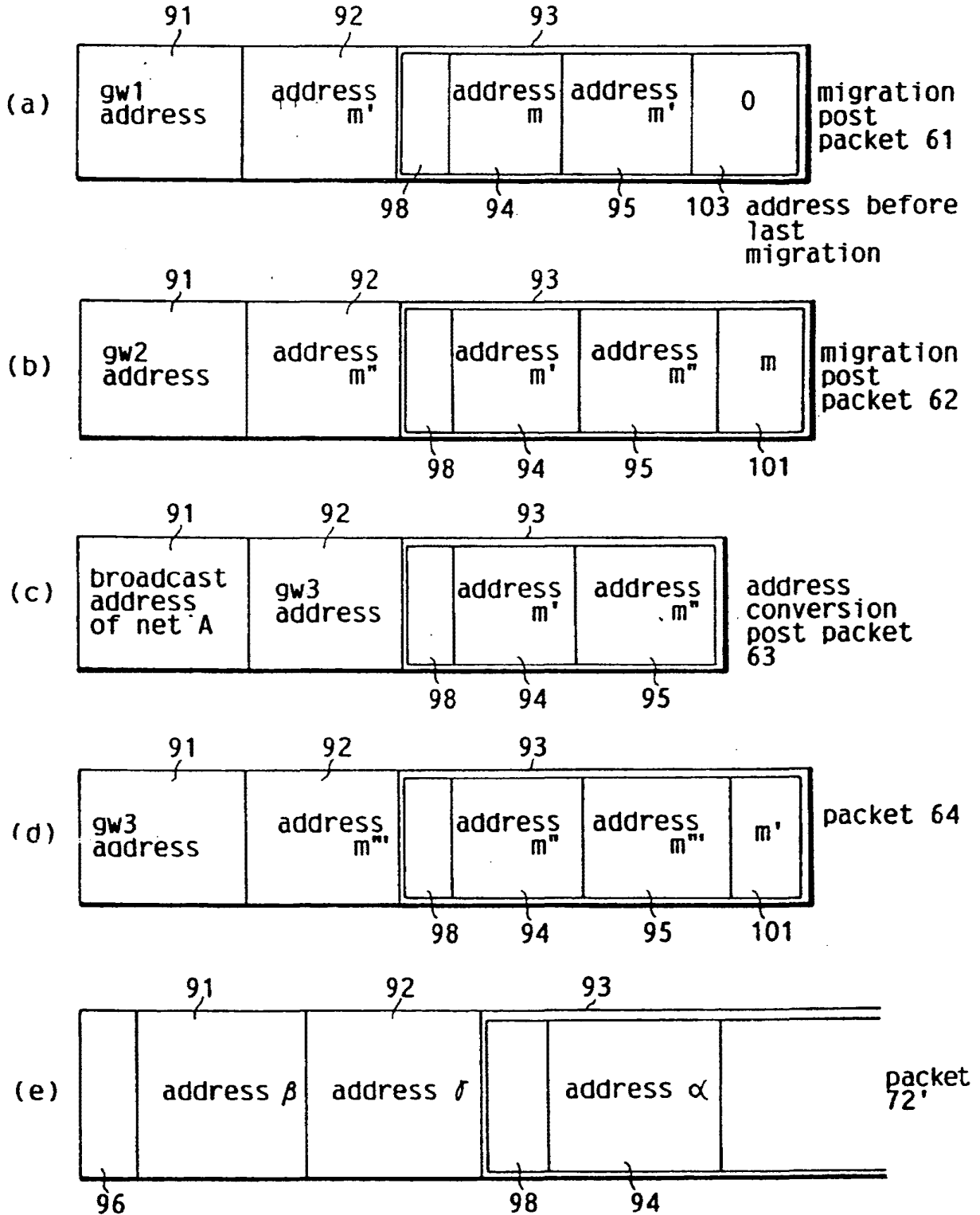


FIG. 12



(a) migration from network A to network B

FIG. 13

gateway	address correspondence	address before last migration
gw1	$m \rightarrow m'$	0
gw2	$m \rightarrow m'$	0
gw3	—	—
gw4	—	—

(b) migration from network B to network C

gateway	address correspondence	address before last migration
gw1	$m \rightarrow m''$	0
gw2	$m \rightarrow m''$ $m' \rightarrow m''$	$\frac{0}{m}$
gw3	$m' \rightarrow m''$	m
gw4	—	—

(c) migration from network C to network D

gateway	address correspondence	address before last migration
gw1	$m \rightarrow m'''$	0
gw2	$m \rightarrow m'''$ $m' \rightarrow m'''$	$\frac{0}{m}$
gw3	$m' \rightarrow m'''$ $m'' \rightarrow m'''$	$\frac{m}{m'}$
gw4	$m'' \rightarrow m'''$	$m'$

(a) migration from network A to network B

FIG. 14

migration communication control device	content of hold unit	
	address correspon- dence	address before last migration
S1	$m \rightarrow m'$	0
S2	—	—
S3	—	—
S4	—	—

(b) migration from network B to network C

migration communication control device	content of hold unit	
	address correspon- dence	address before last migration
S1	$m \rightarrow m''$	0
S2	$m' \rightarrow m''$	m
S3	—	—
S4	—	—

(c) migration from network C to network D

migration communication control device	content of hold unit	
	address correspon- dence	address before last migration
S1	$m \rightarrow m'''$	0
S2	$m' \rightarrow m'''$	m
S3	$m'' \rightarrow m'''$	$m'$
S4	—	—

FIG. 15

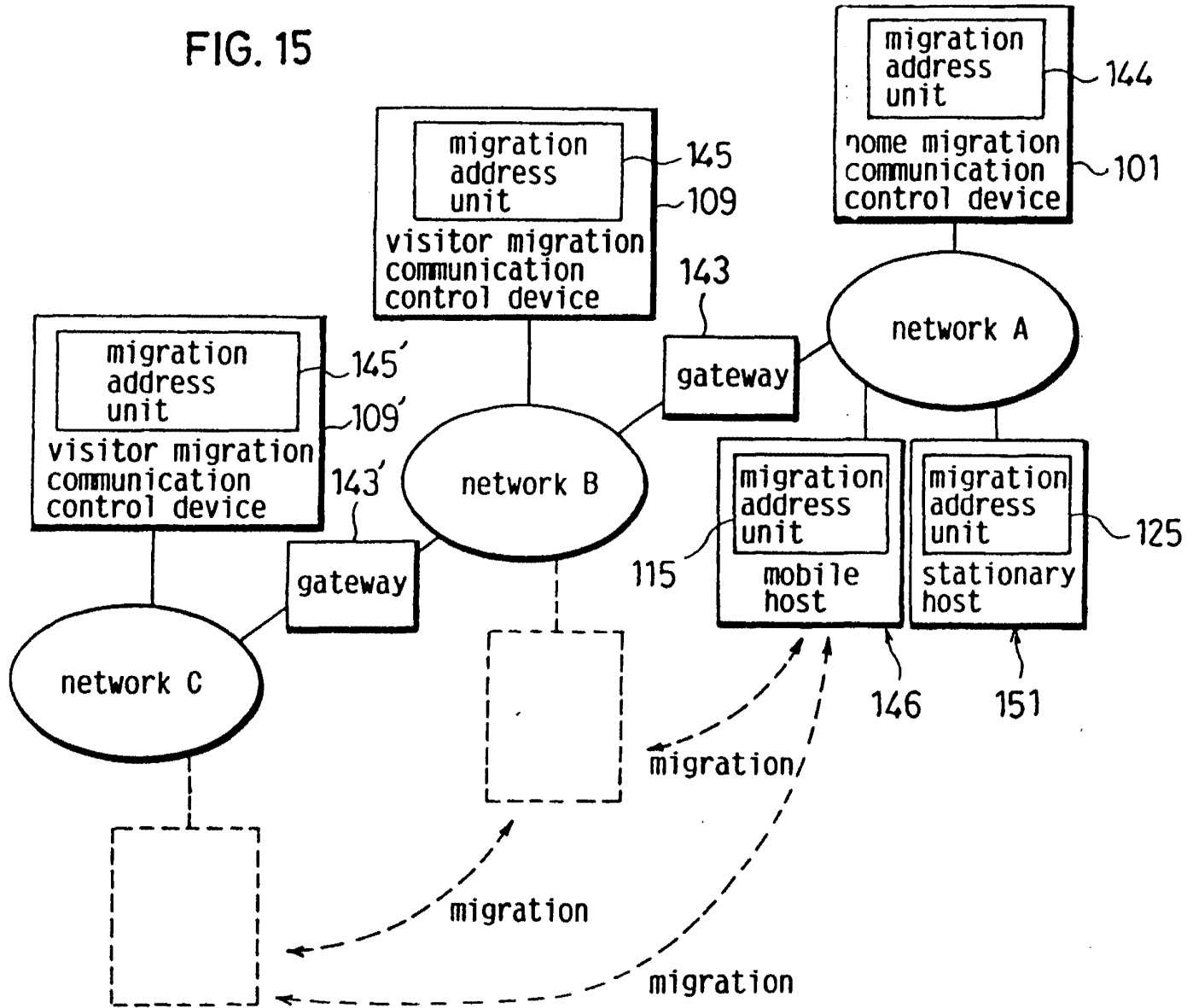


FIG. 16

home migration communication control device 101

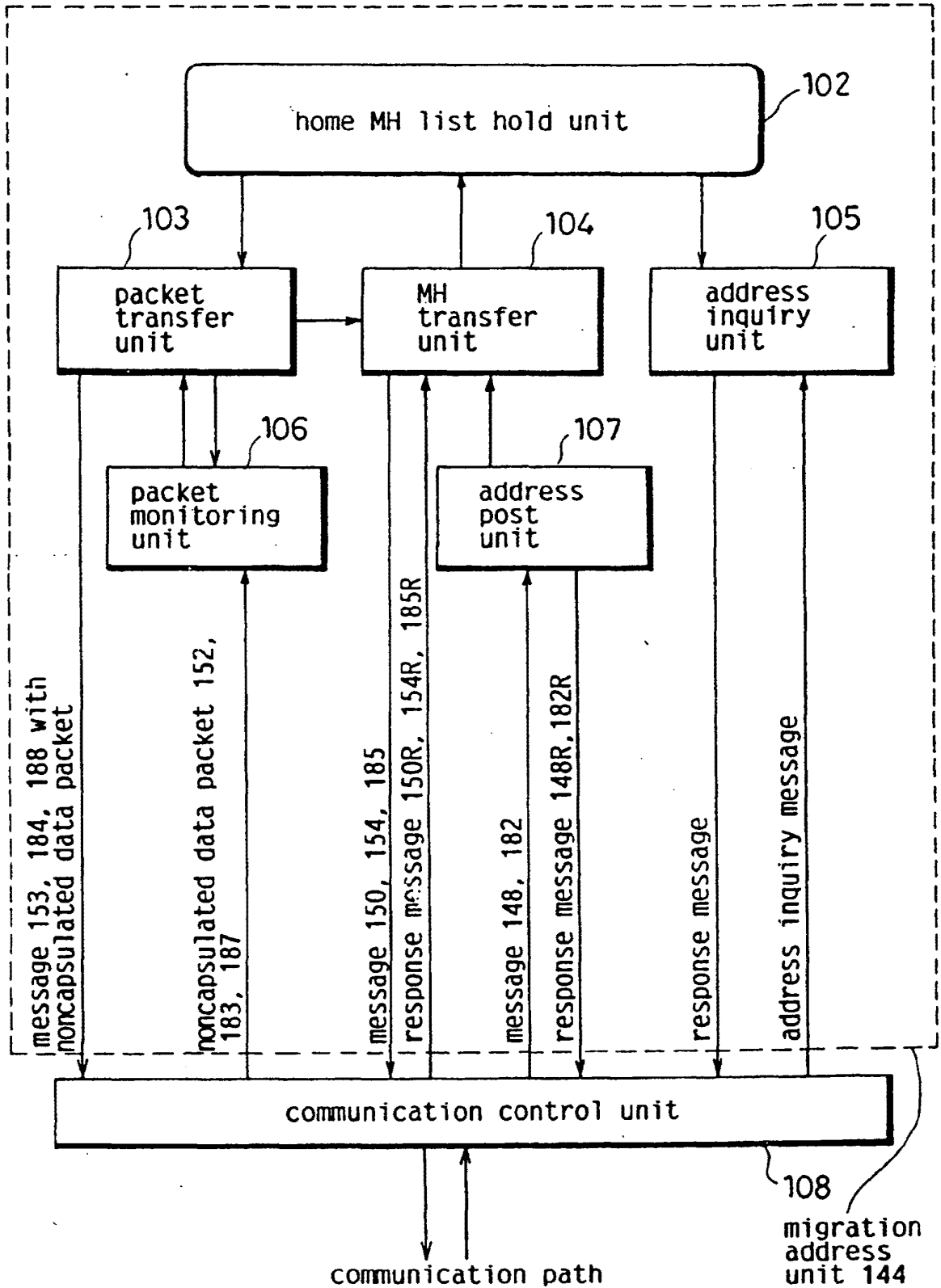


FIG. 17

MH's home address	MH's current temporary address	autonomous flag F	current broadcast address
$\alpha$	$\beta$ or $\delta$	1	Bba or Cba



FIG. 18

visitor migration communication control device 109(109')

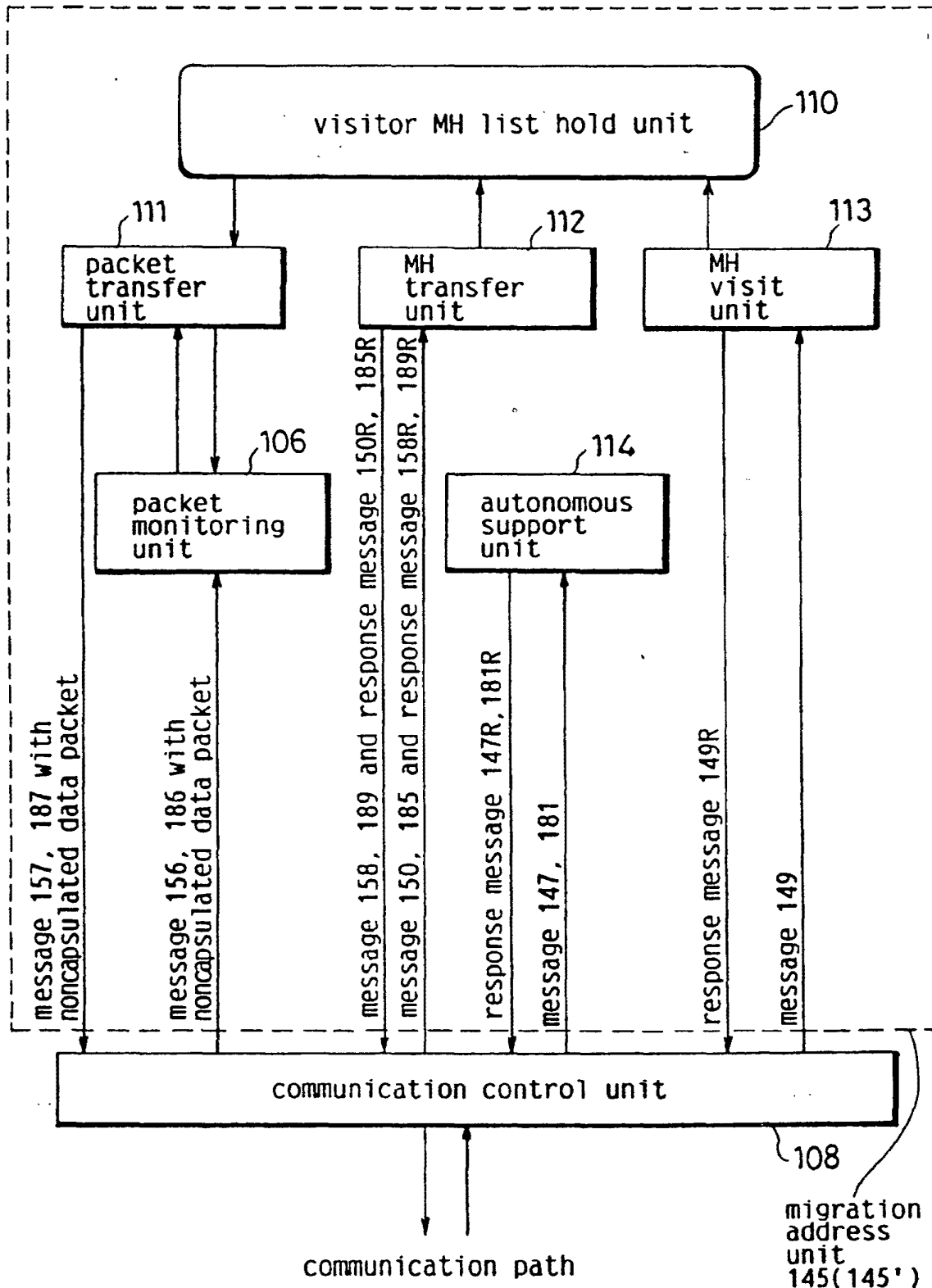


FIG. 19

MH's home address	temporary address	temporary address after migration	autonomous flag F
$\alpha$	$\beta$	$\delta$	1

FIG. 20

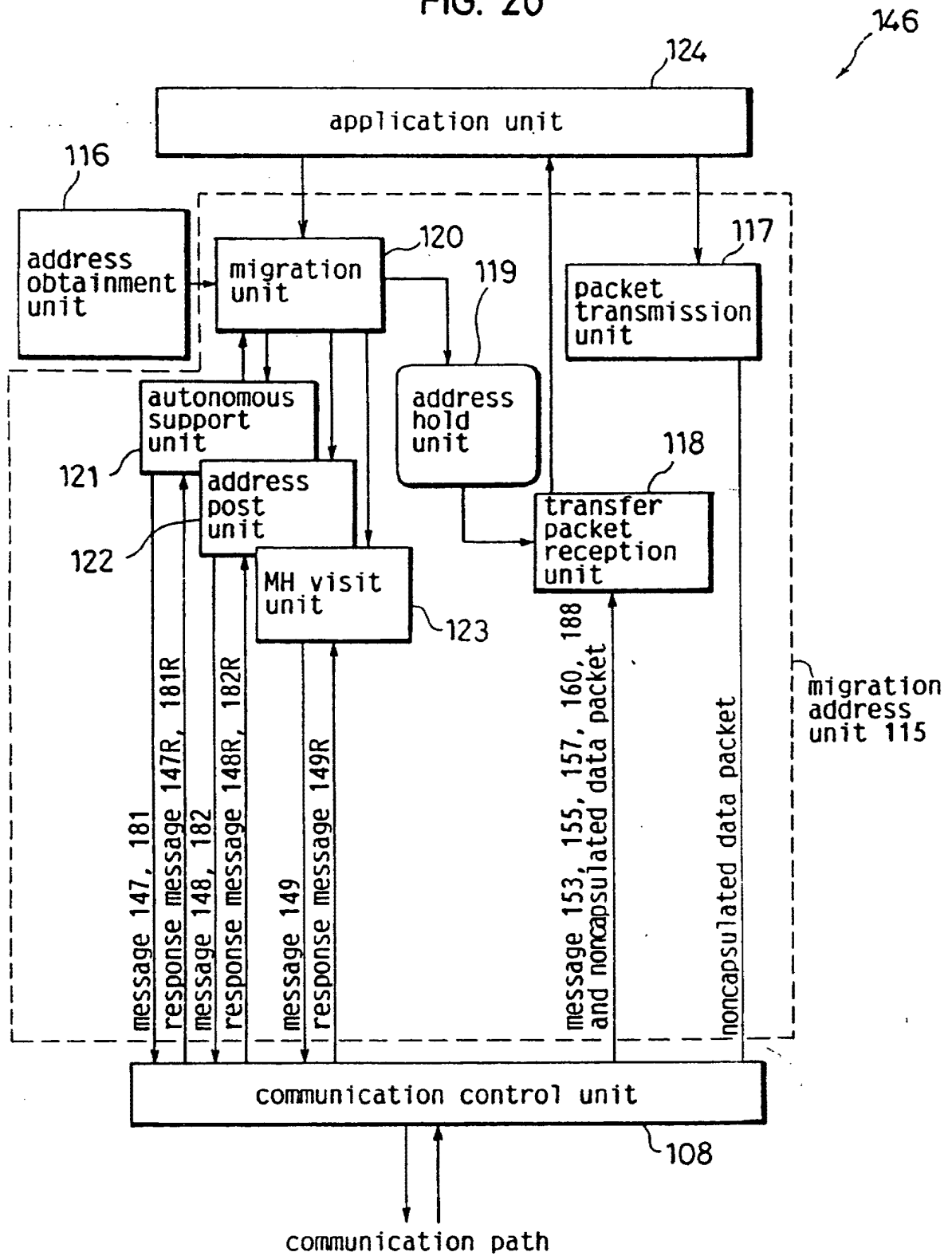


FIG. 21

home address	broadcast address of home network	current temporary address	broadcast address
$\alpha$	Aba	$\beta$ or $\delta$	Bba or Cba

FIG. 22

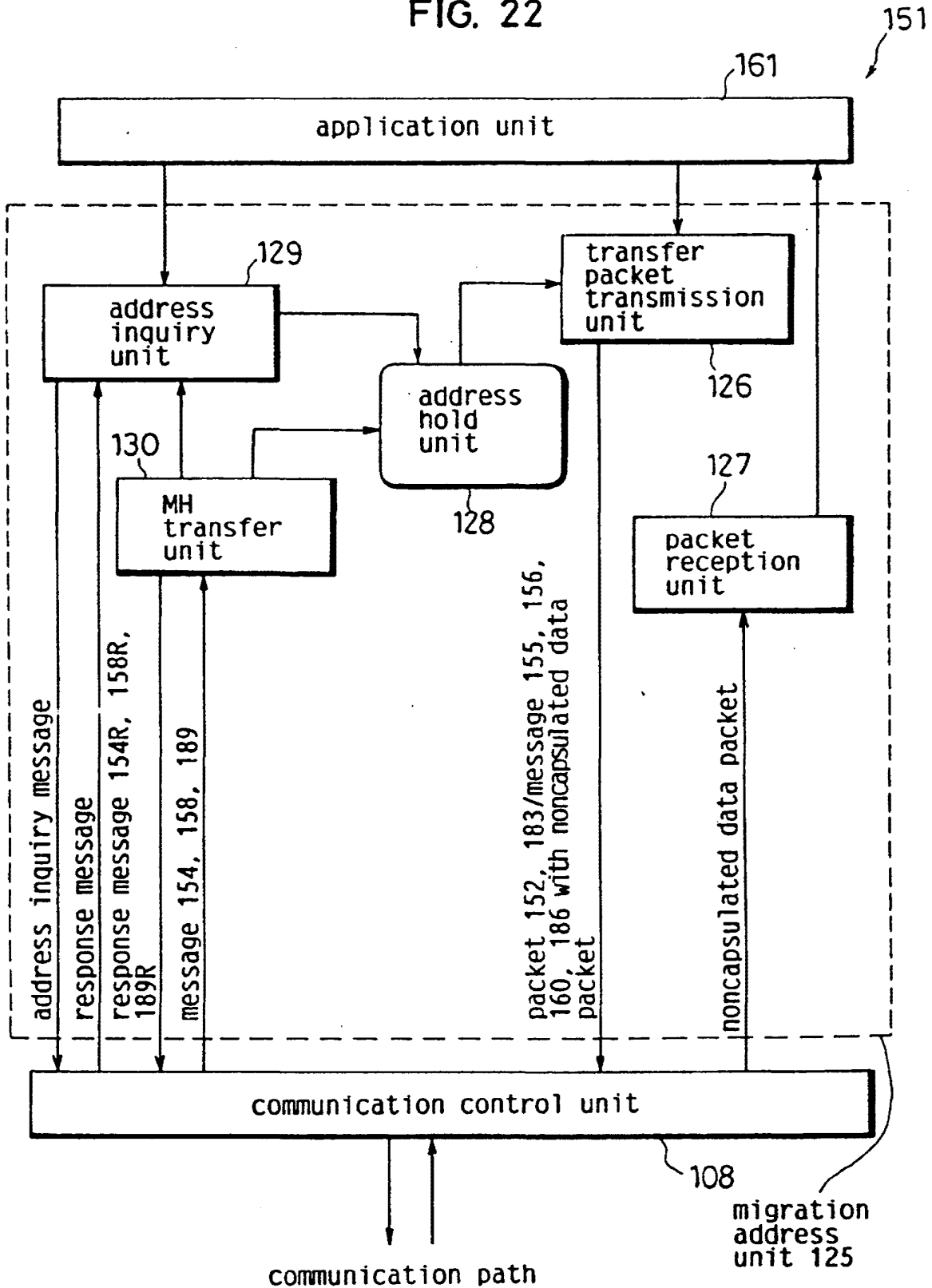
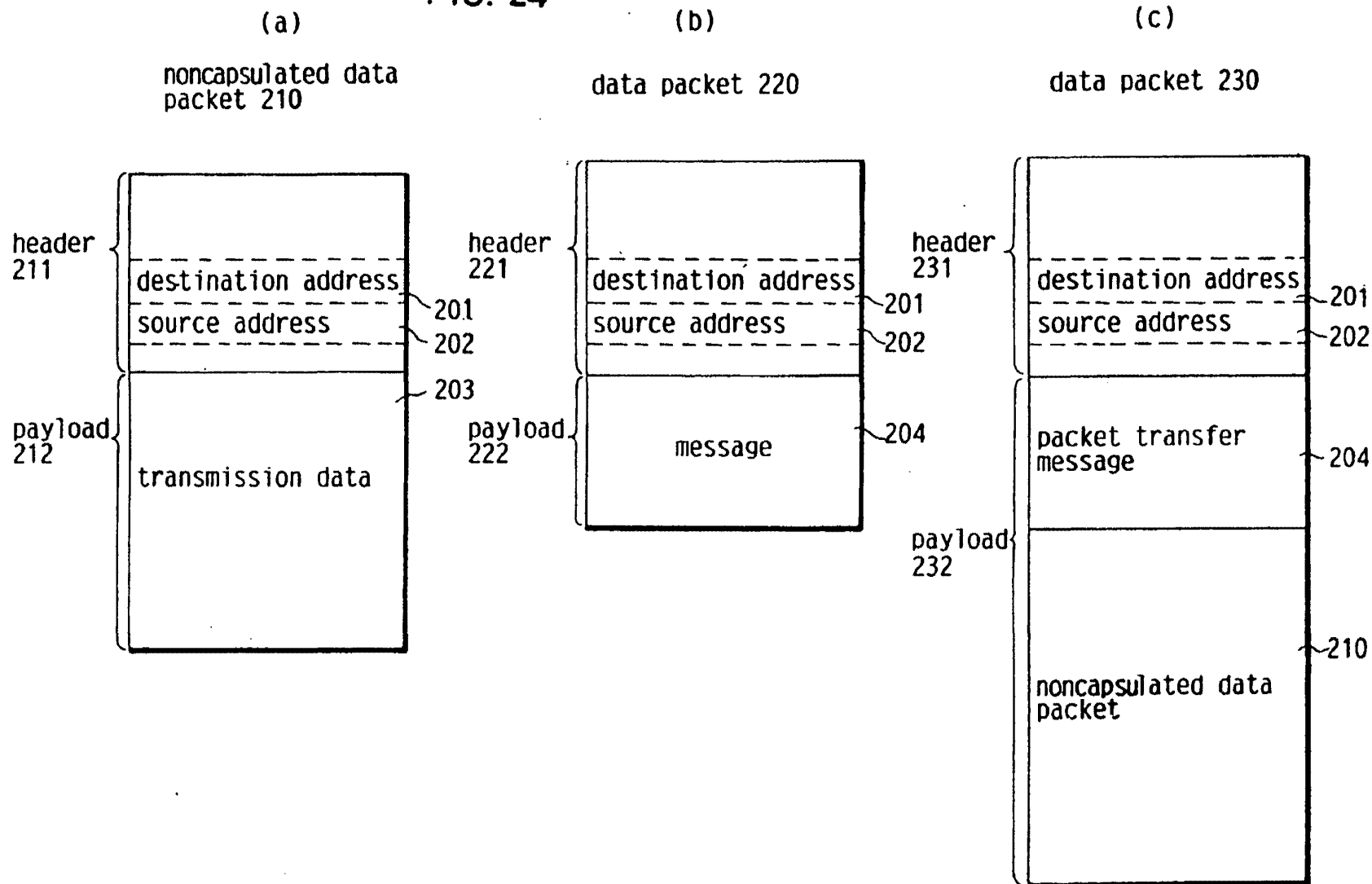


FIG. 23

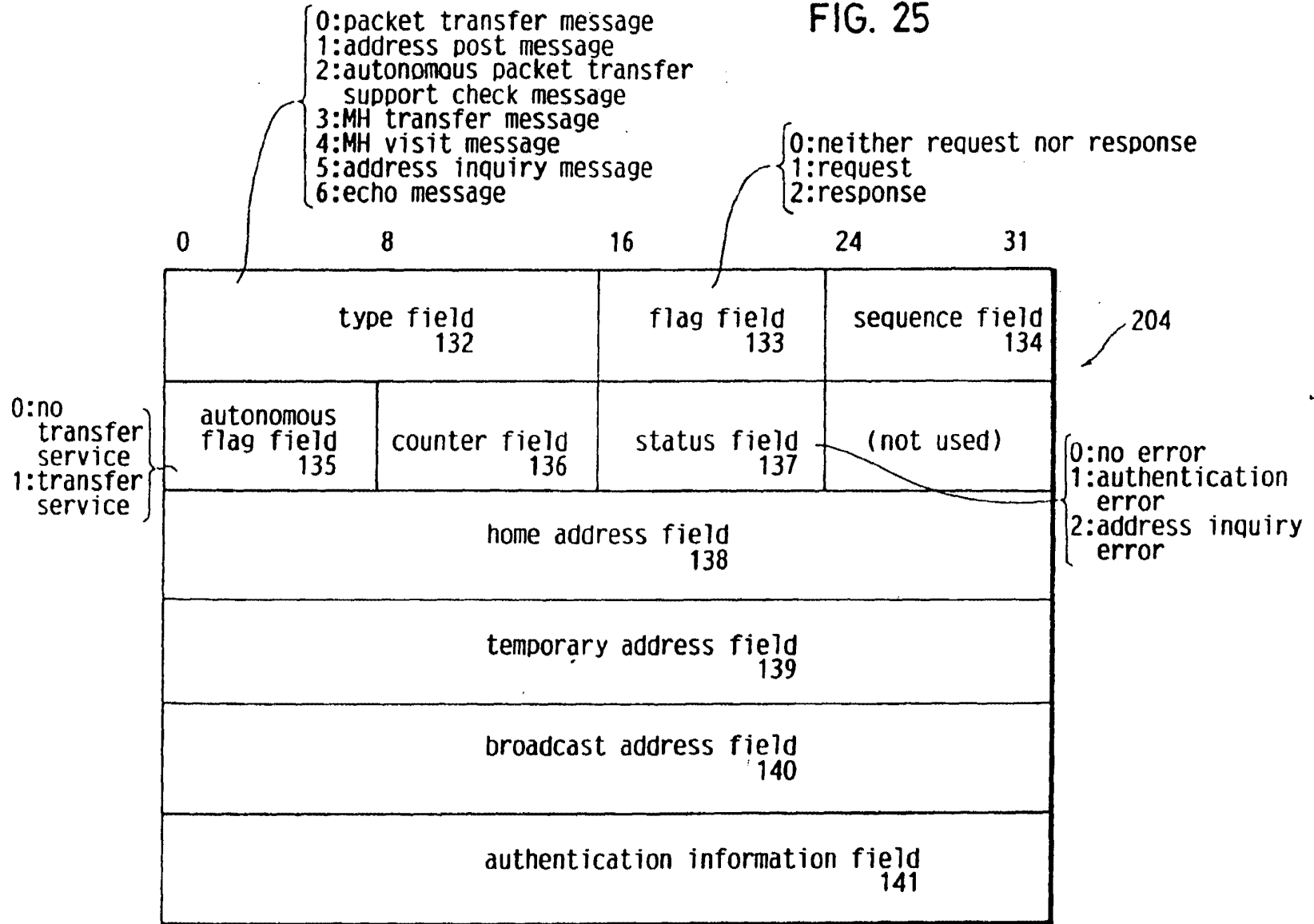
MH's home address	MH's temporary address
$\alpha$	$\beta$ or $\delta$

FIG. 24



EP 0 556 012 A2

FIG. 25



59



FIG. 26

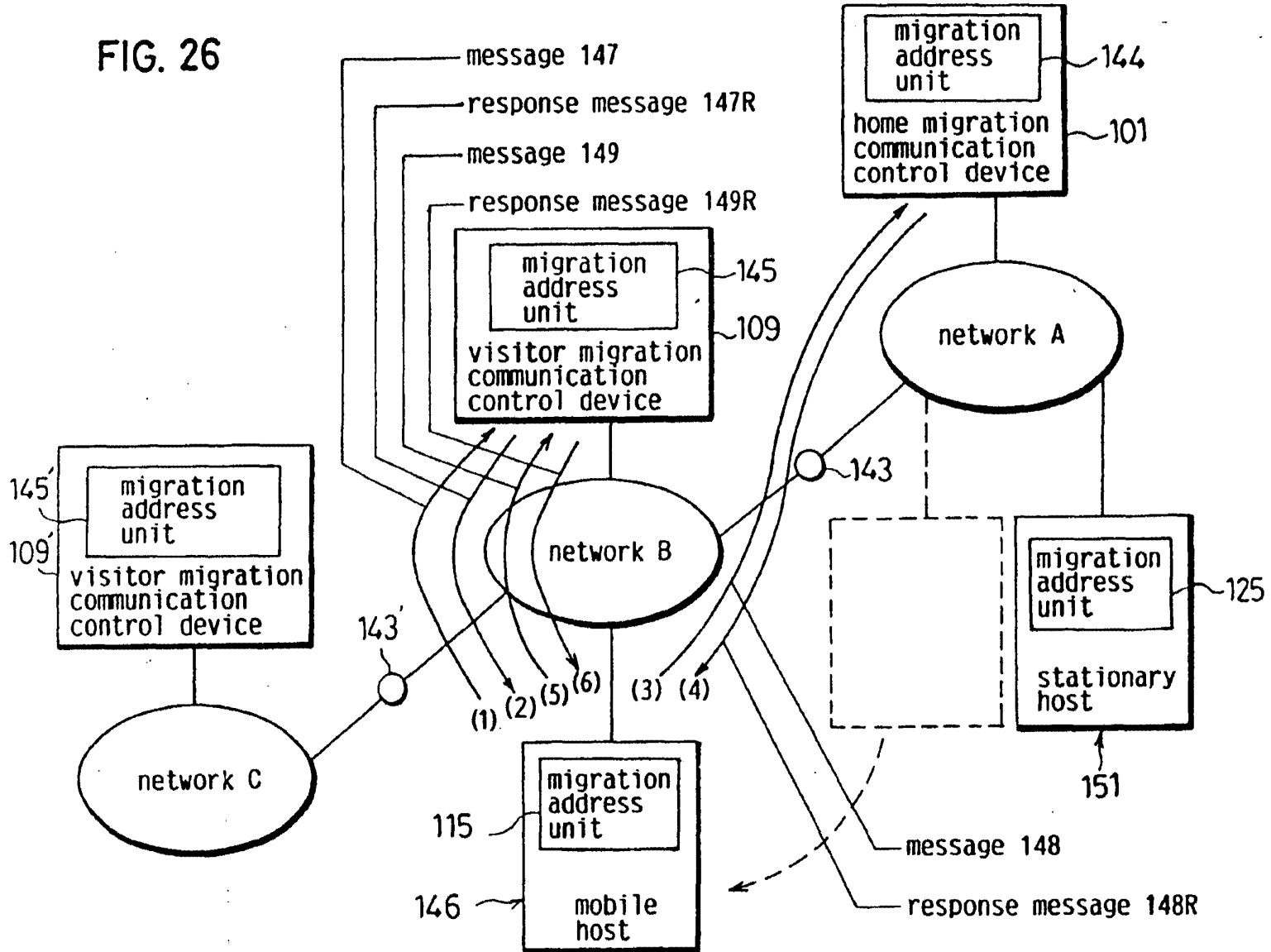


FIG. 27 migration from network A to network B

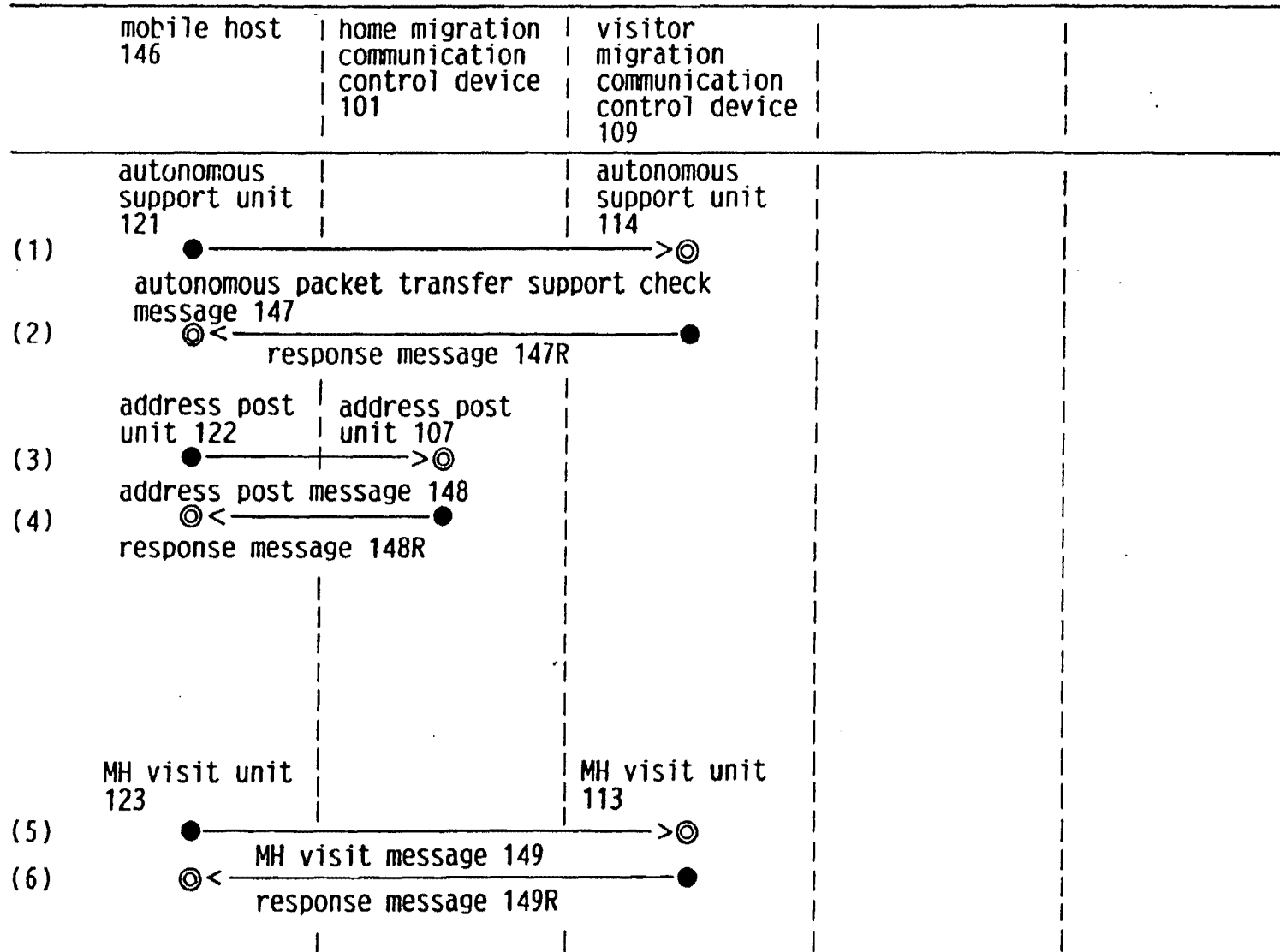
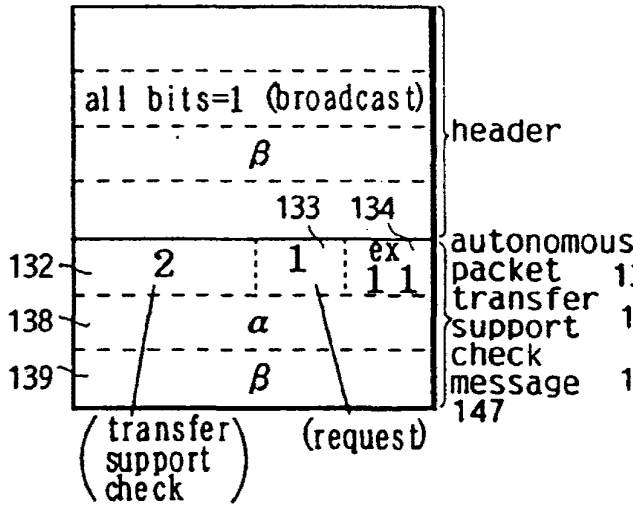
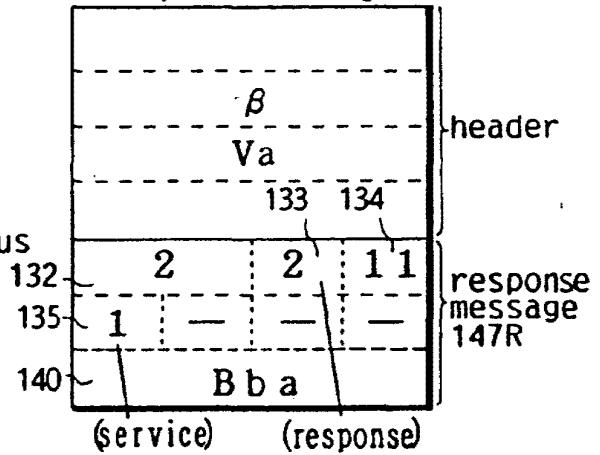


FIG.28

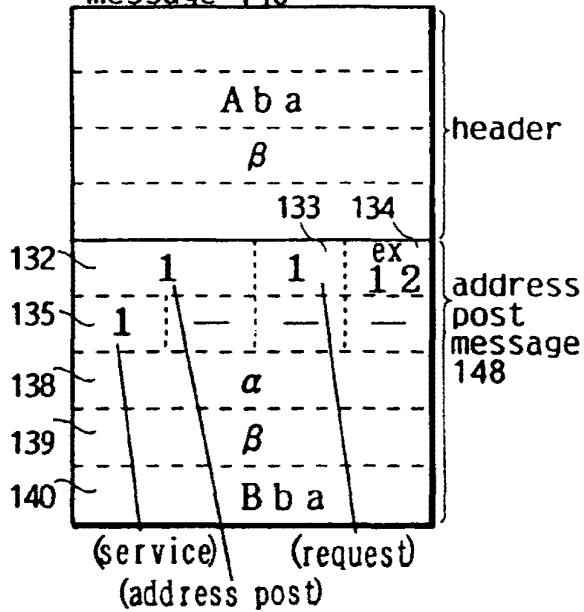
(1) data packet including message 147



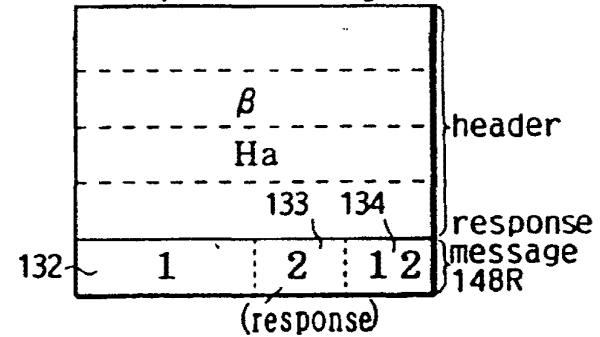
(2) data packet including response message 147R



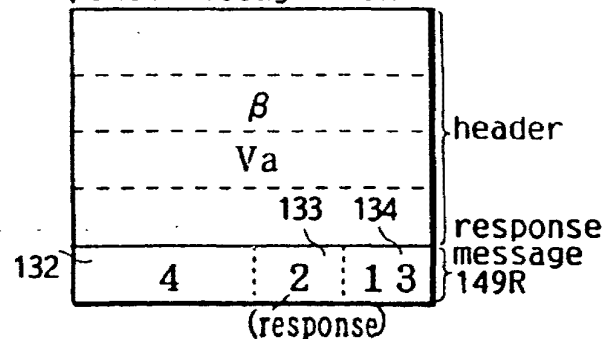
(3) data packet including message 148



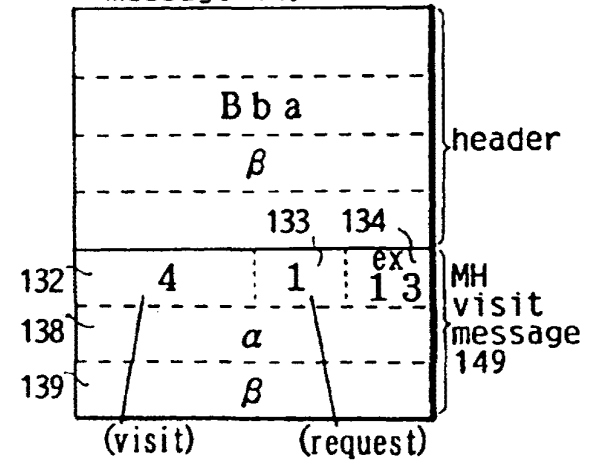
(4) data packet including response message 148R



(6) data packet including response message 149R



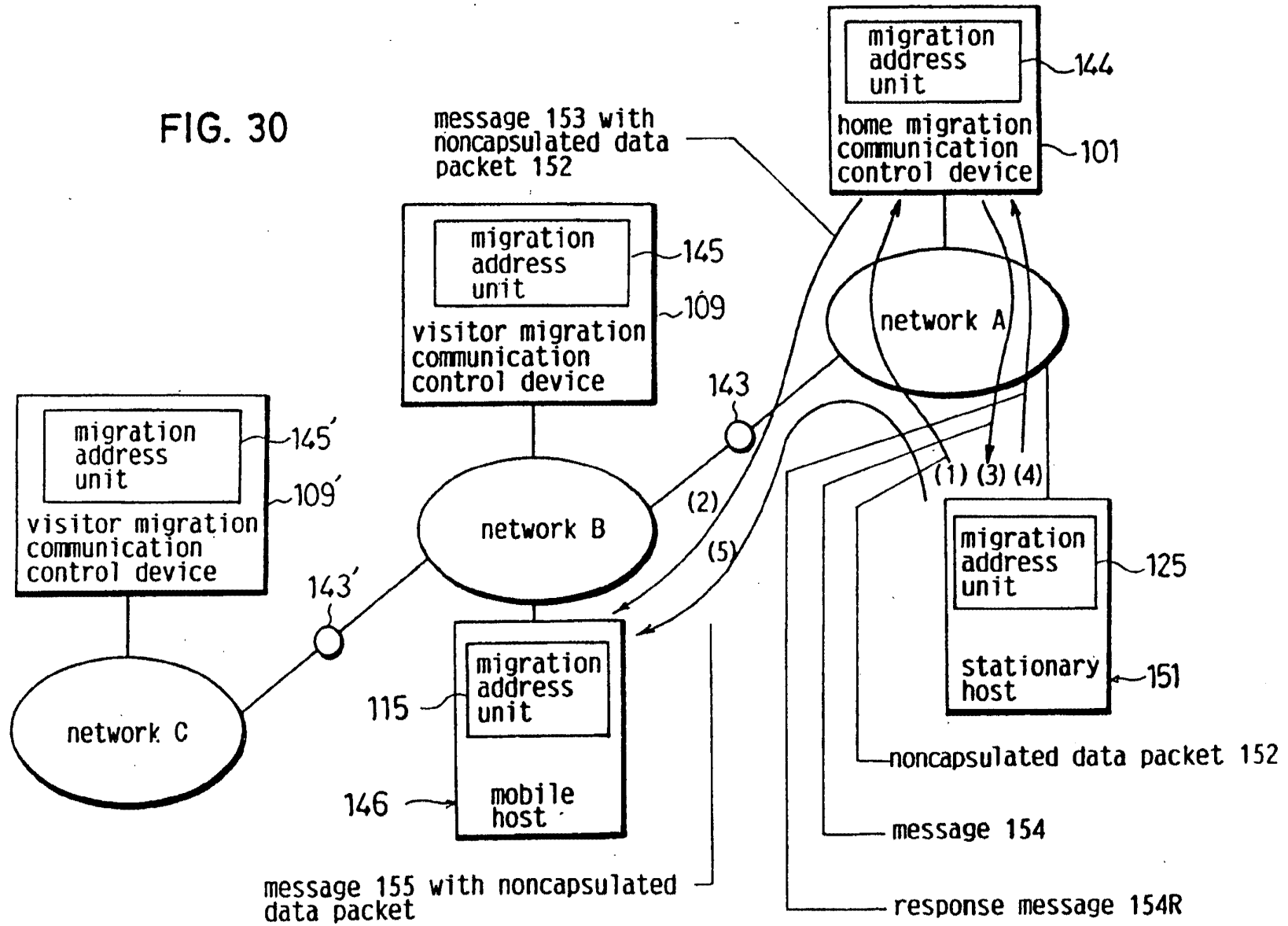
(5) data packet including message 149



address after obtainment of $\beta$	address hold unit 119(146)				home MH host list hold unit 102(101)				visitor MH list hold unit 110(109)				visitor MH list hold unit 110(109)				address hold unit 128(151)		
	$\alpha$	Aba	$\beta$	-	$\alpha$	$\alpha$	-	-	-	-	-	-	-	-	-	-	-		
(1)																			
(2)	$\alpha$	Aba	$\beta$	-															
(3)					$\alpha$	$\beta$	1	Bda											
(4)																			
(5)									$\alpha$	$\beta$	$\beta$	-							
(6)																			

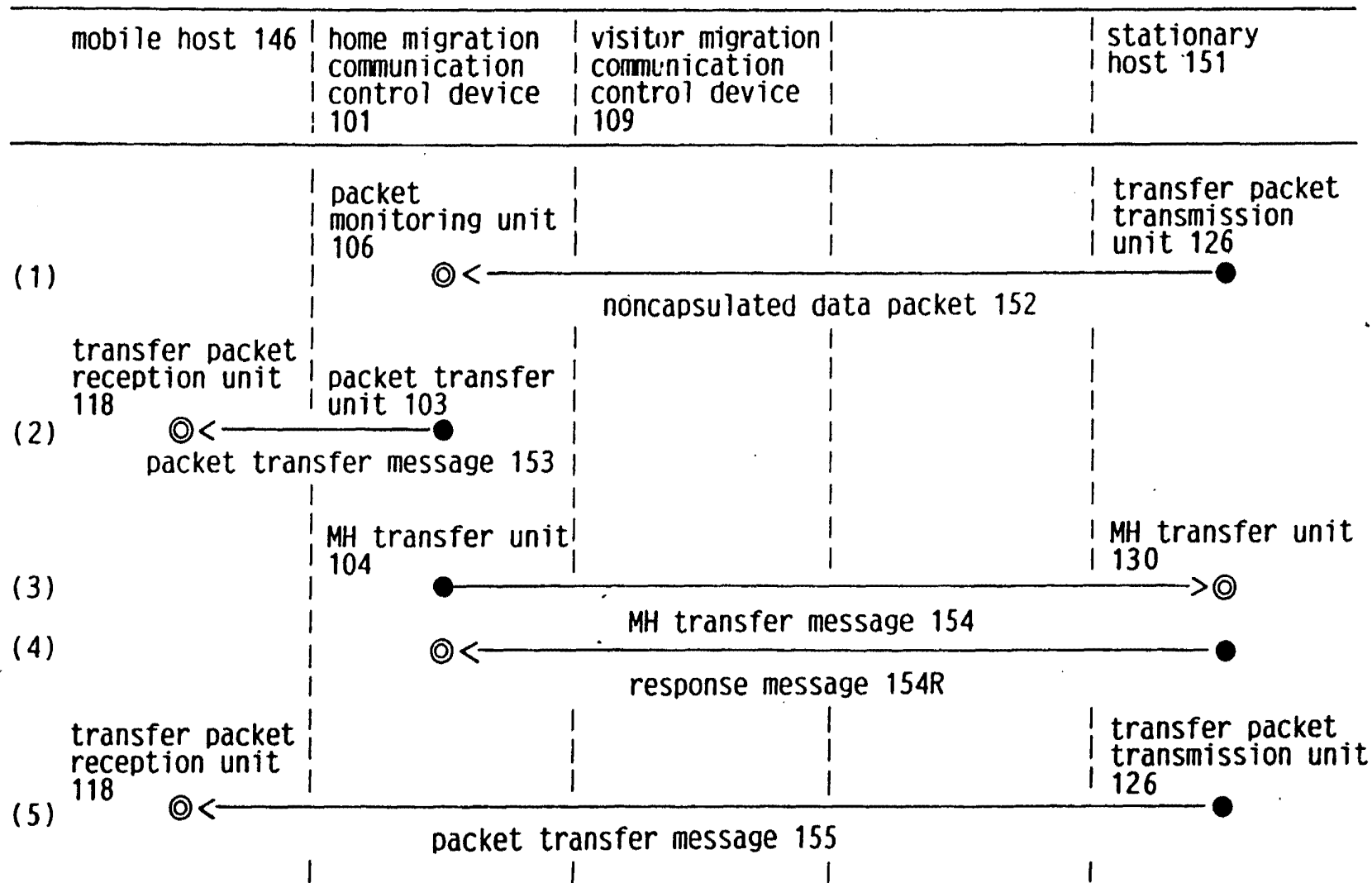
FIG. 29

FIG. 30



# FIG. 31

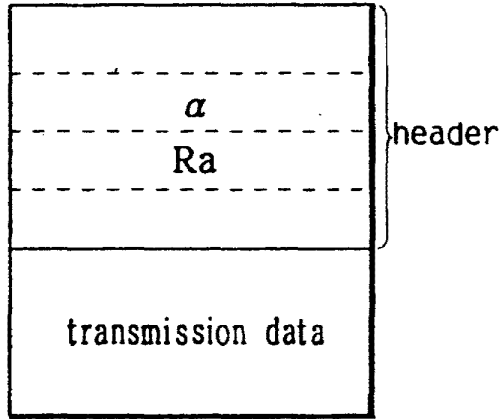
data packet from SH 151 to MH 146 on network B



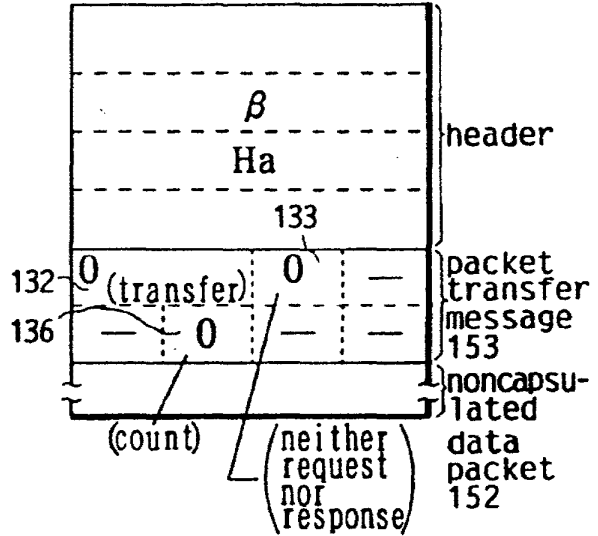
65

FIG. 32

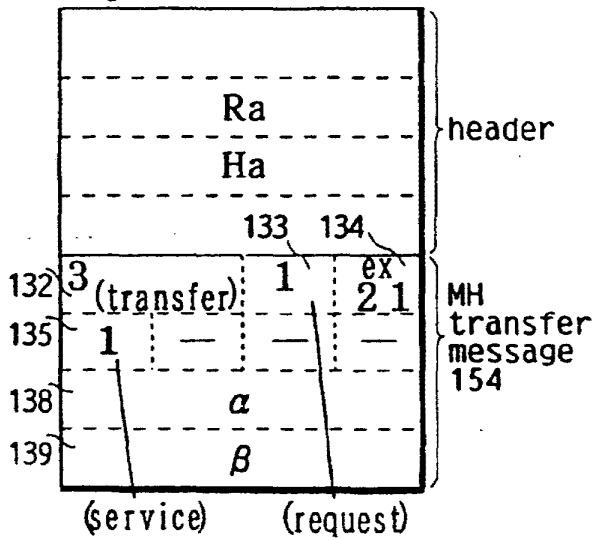
(1) noncapsulated data packet 152



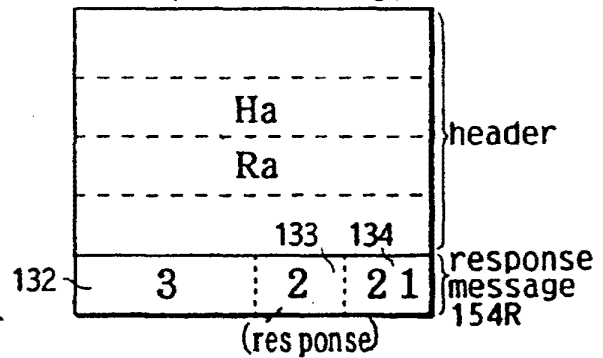
(2) data packet including message 153 and noncapsulated data packet



(3) data packet including message 154



(4) data packet including response message 154R



(5) data packet including message 155 and noncapsulated data packet

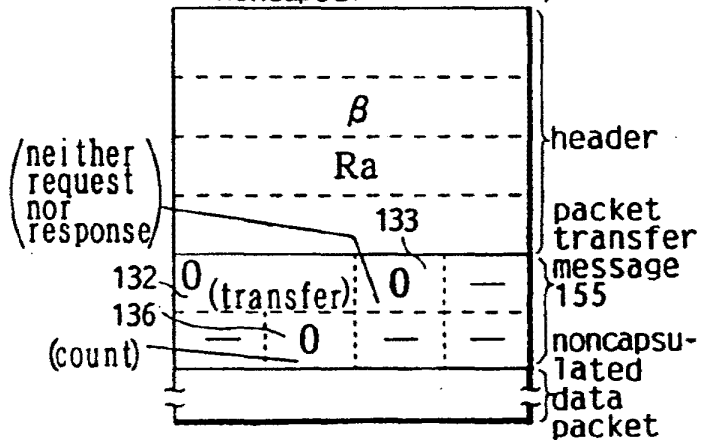
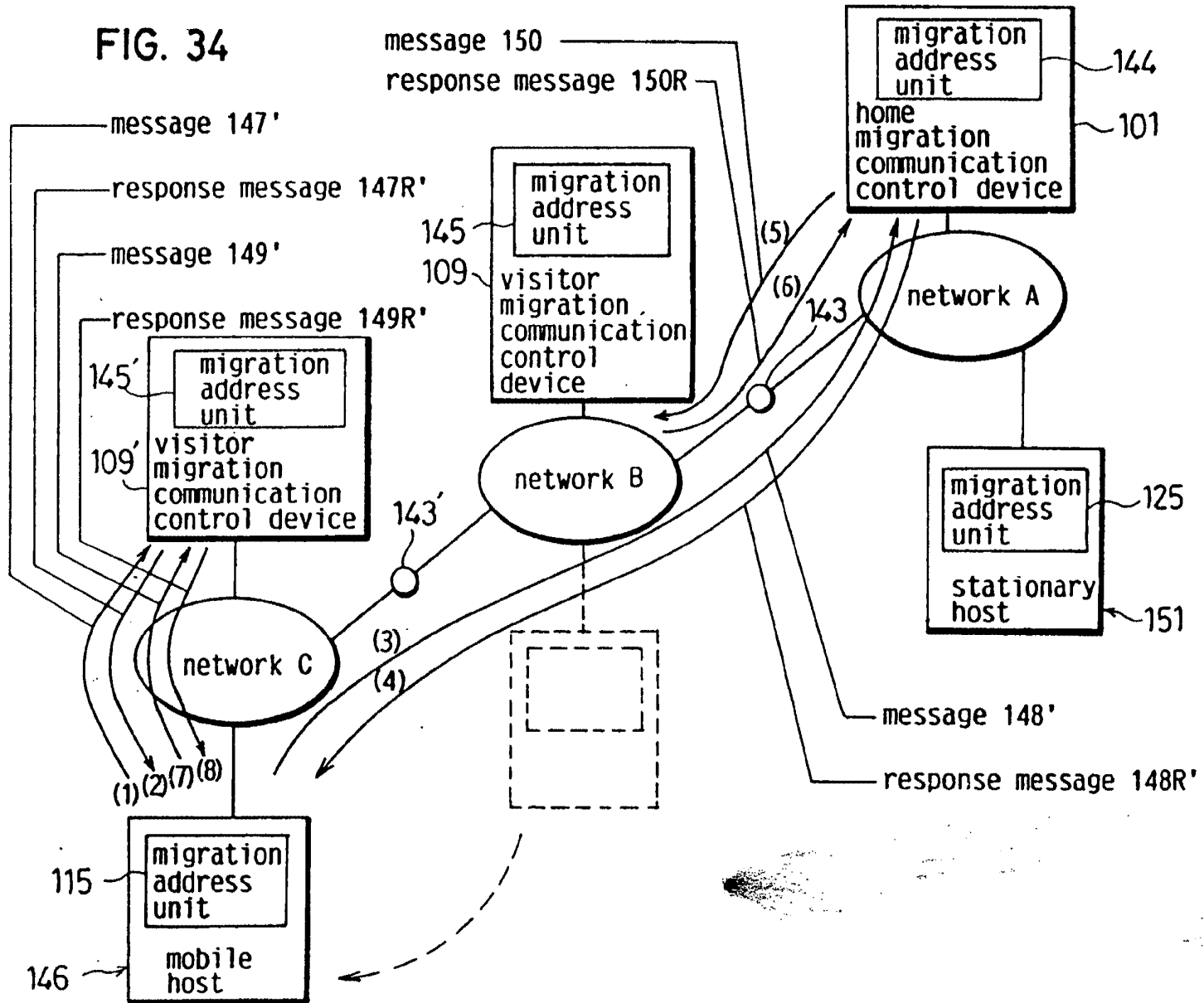


FIG. 33

address before communica- tion	address hold unit 119(146)				home MH list hold unit 102(101)				visitor MH list hold unit 110(109)				visitor MH list hold unit 110'(109)				address hold unit 128(151)	
	$\alpha$	Aba	$\beta$	Bba	$\alpha$	$\beta$	1	Bba	$\alpha$	$\beta$	$\beta$	1	1	1	1	1	$\alpha$	$\beta$
(1)																		
(2)																		
(3)																	$\alpha$	$\beta$
(4)																		
(5)																		

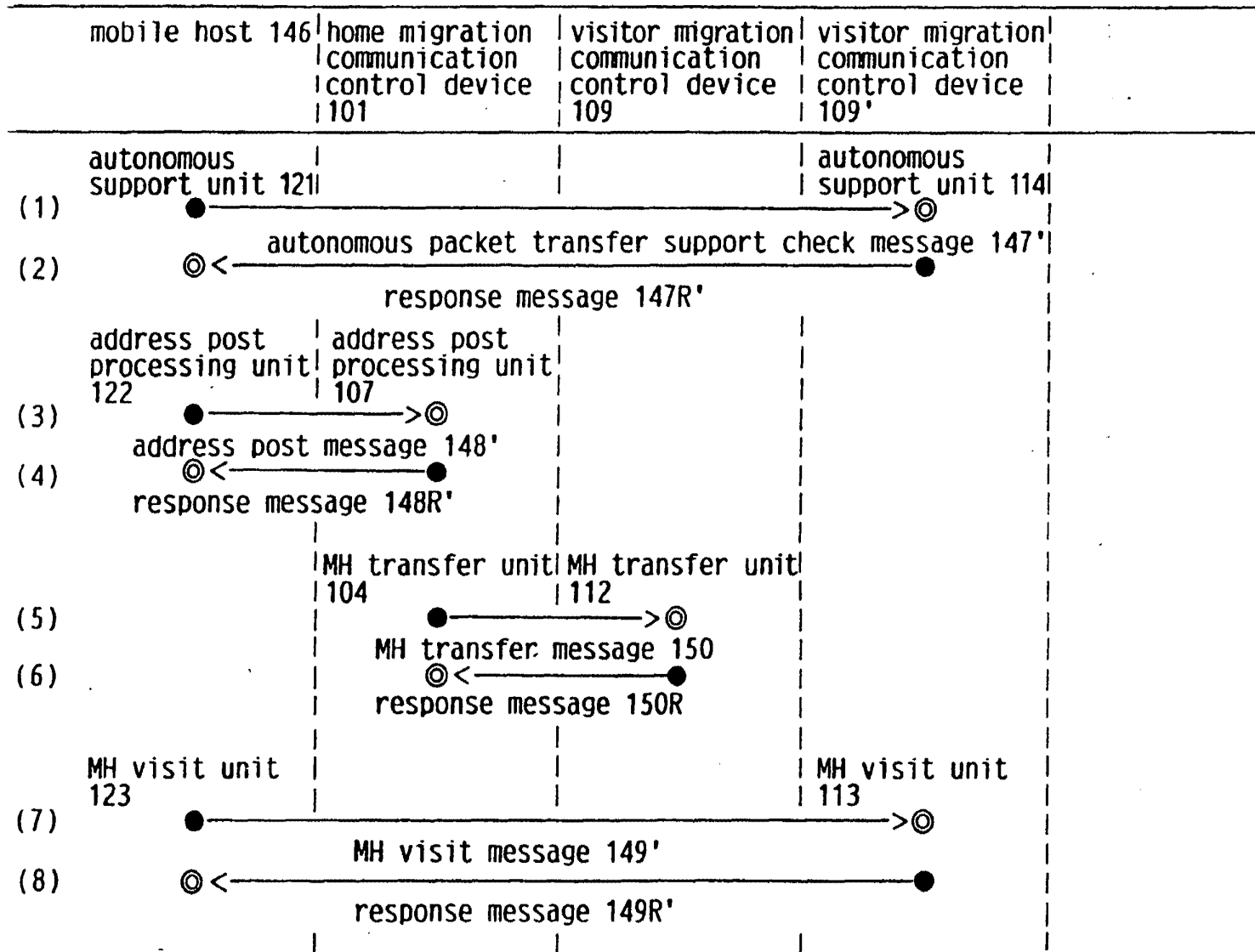


FIG. 34

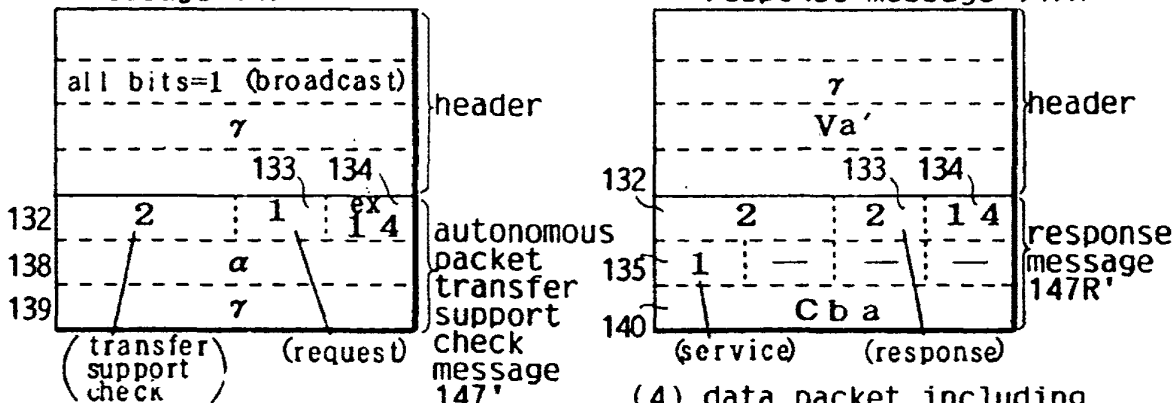


EP 0 556 012 A2

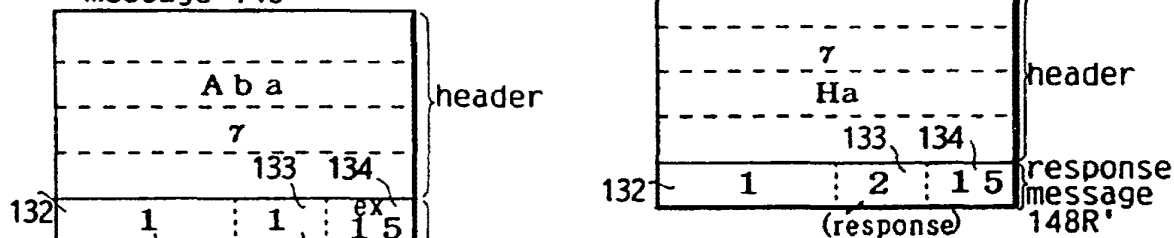
FIG. 35 migration from network B to network C



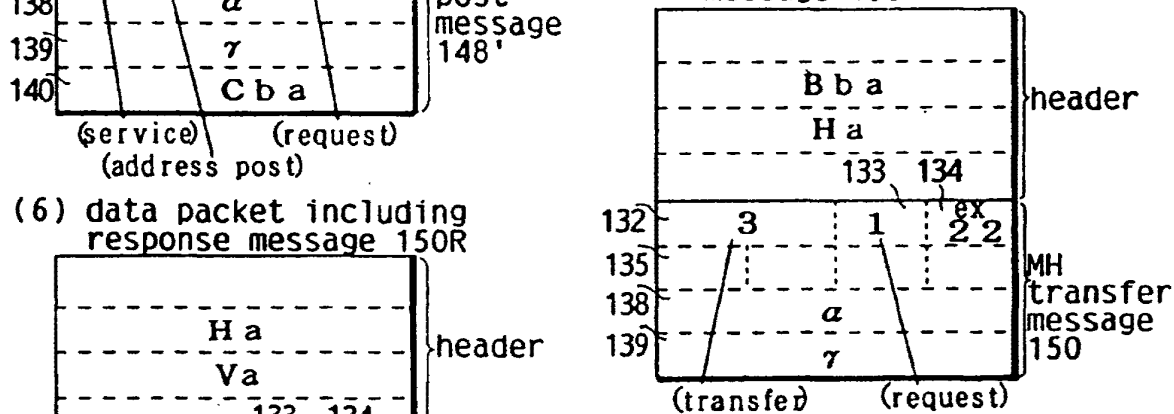
(1) data packet including message 147' (2) data packet including response message 147R'



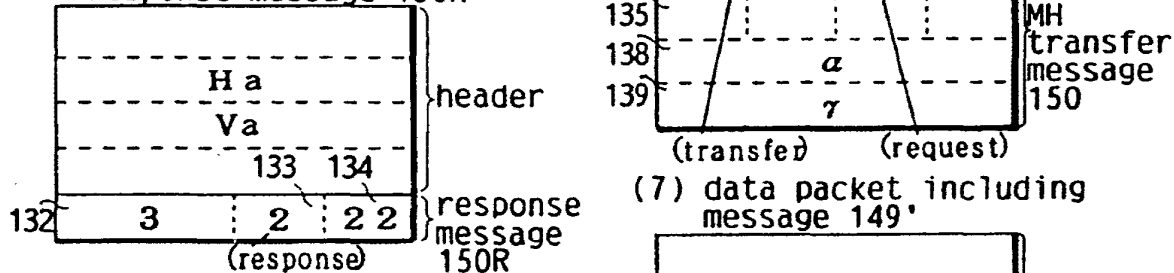
(3) data packet including message 148' (4) data packet including response message 148R'



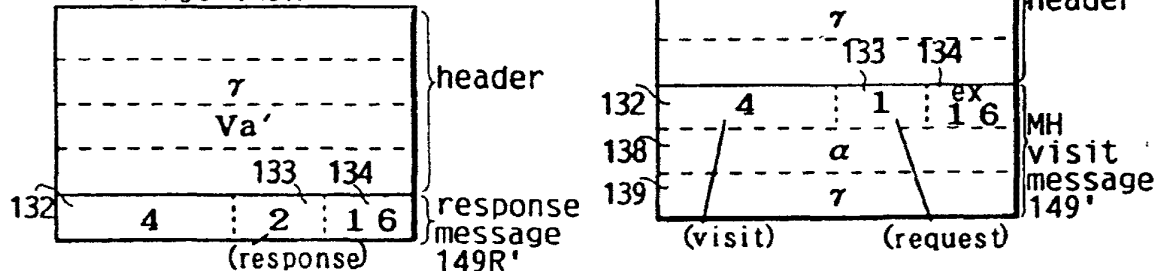
(5) data packet including message 150



(6) data packet including response message 150R



(7) data packet including message 149'



(8) data packet including message 149R'

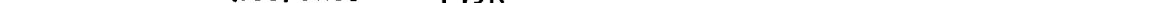
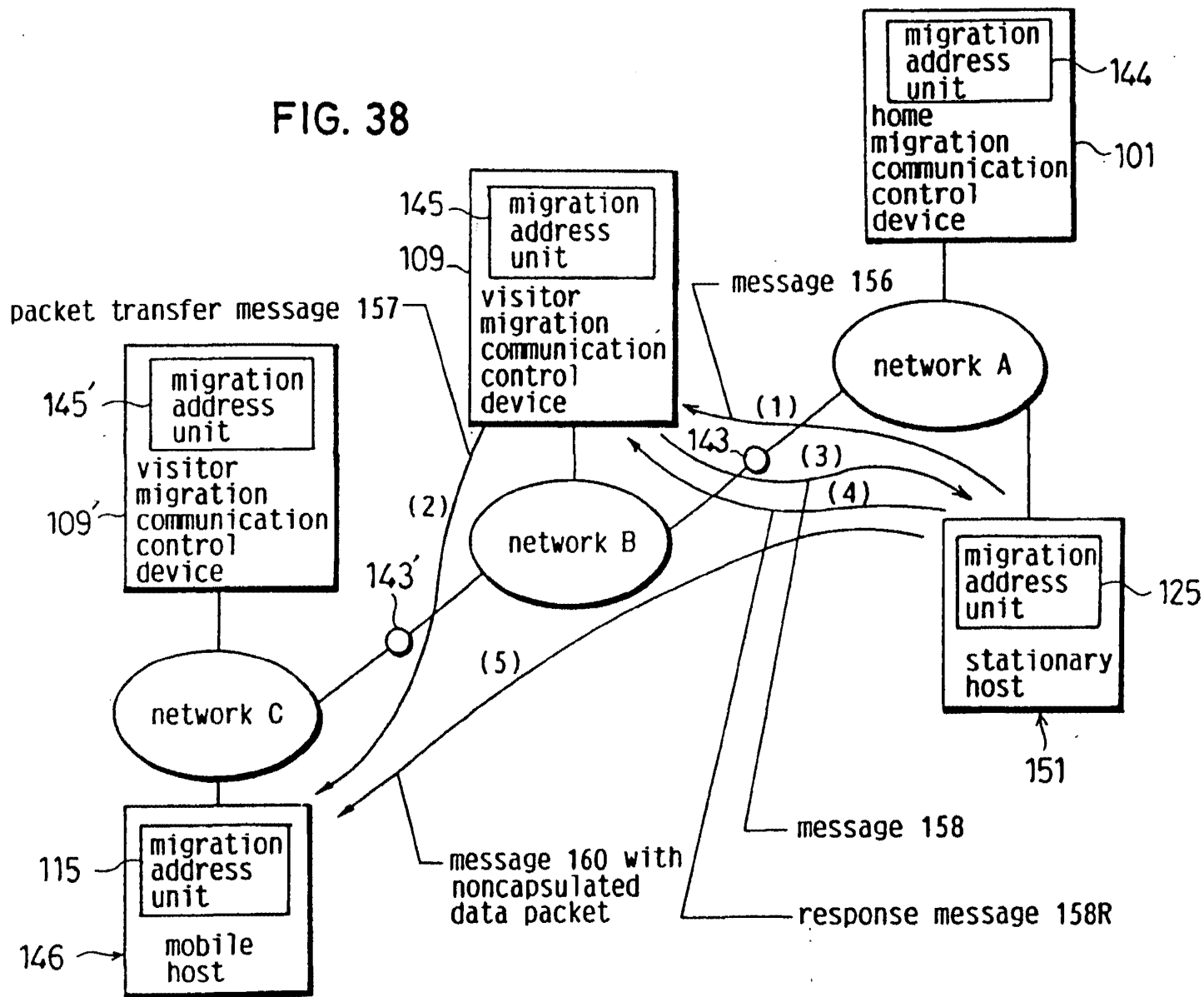


FIG. 37

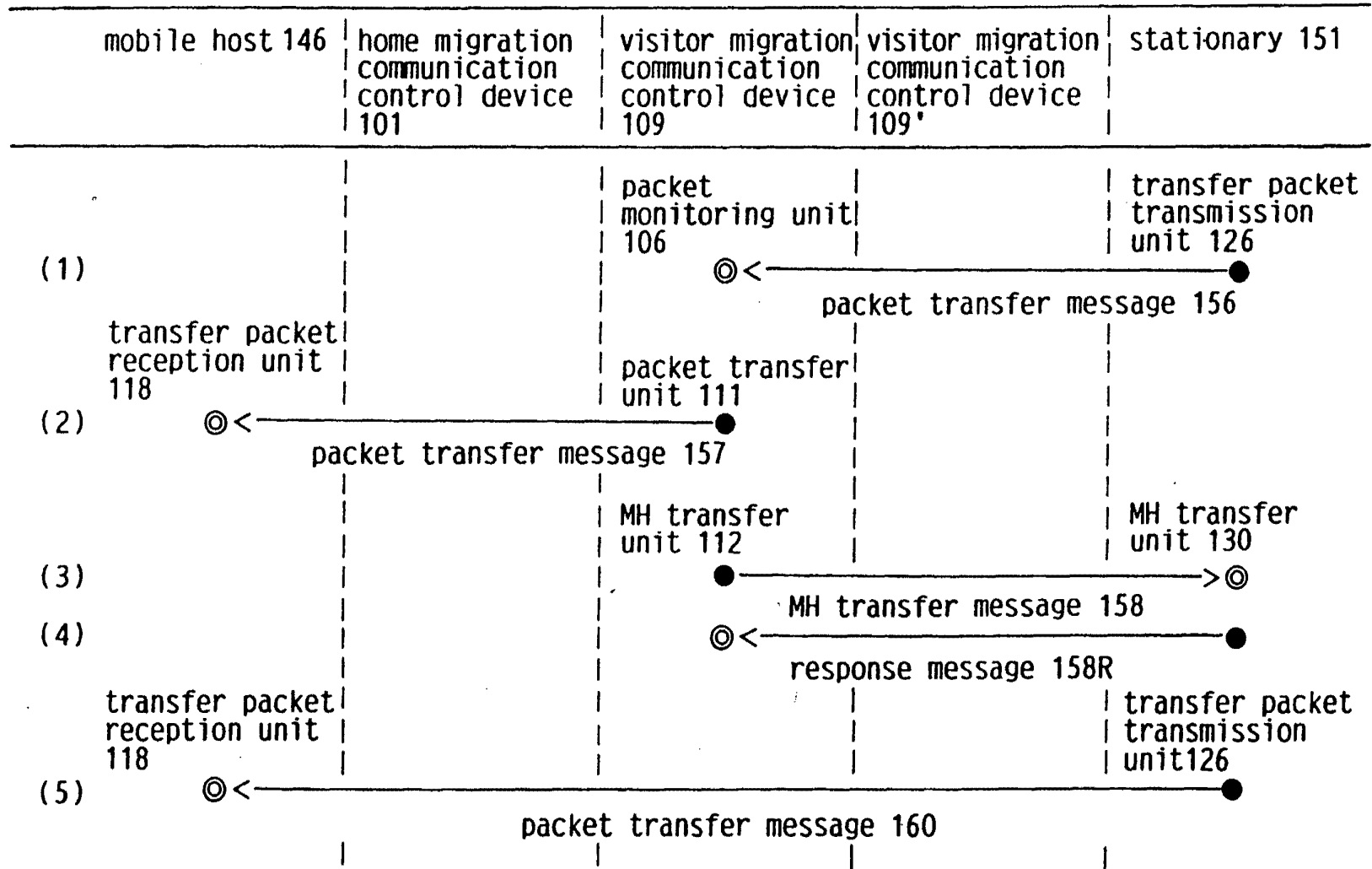
address after obtaining of $\beta$	address hold unit 119(146)				home MH 1st hold unit 102(101)				visitor MH 1st hold unit 110(109)				visitor MH 1st hold unit 110(109)				address hold unit 128(151)	
	$\alpha$	Aba	$\beta$	Bba	$\alpha$	$\beta$	1	Bba	$\alpha$	$\beta$	$\beta$	-	-	-	-	$\alpha$	$\beta$	
(1)																		
(2)	$\alpha$	Aba	$\beta$	Bba														
(3)					$\alpha$	$\beta$	1	Cba										
(4)																		
(5)									$\alpha$	$\beta$	$\beta$	1						
(6)															$\alpha$			
(7)															$\beta$			
(8)																		

FIG. 38



# FIG. 39

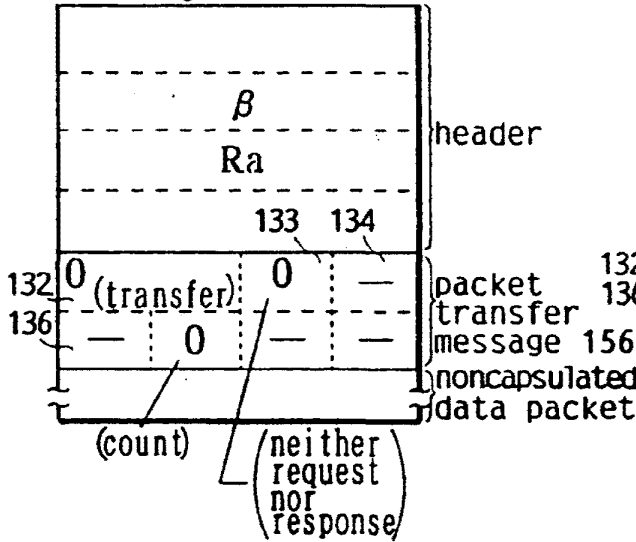
data packet from SH 151 to MH on network C



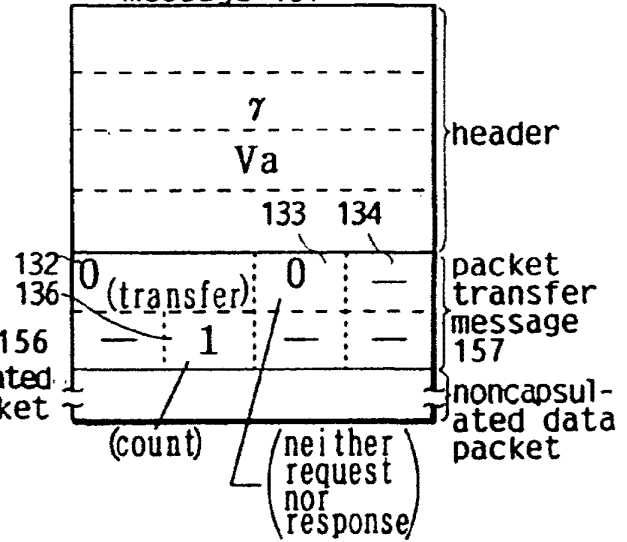
73

FIG. 40

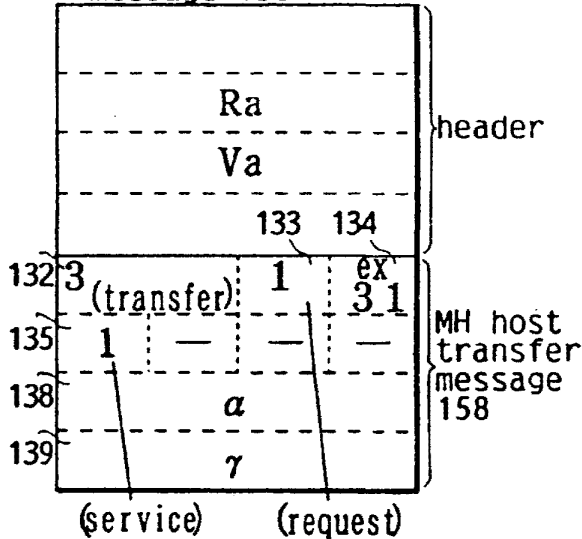
(1) data packet including message 156



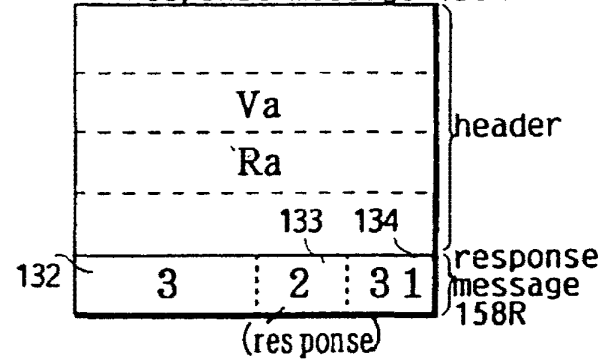
(2) data packet including message 157



(3) data packet including message 158



(4) data packet including response message 158R



(5) data packet including message 160

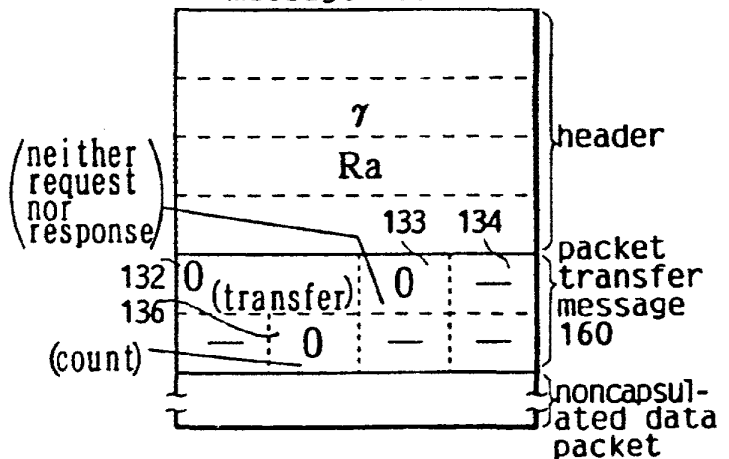
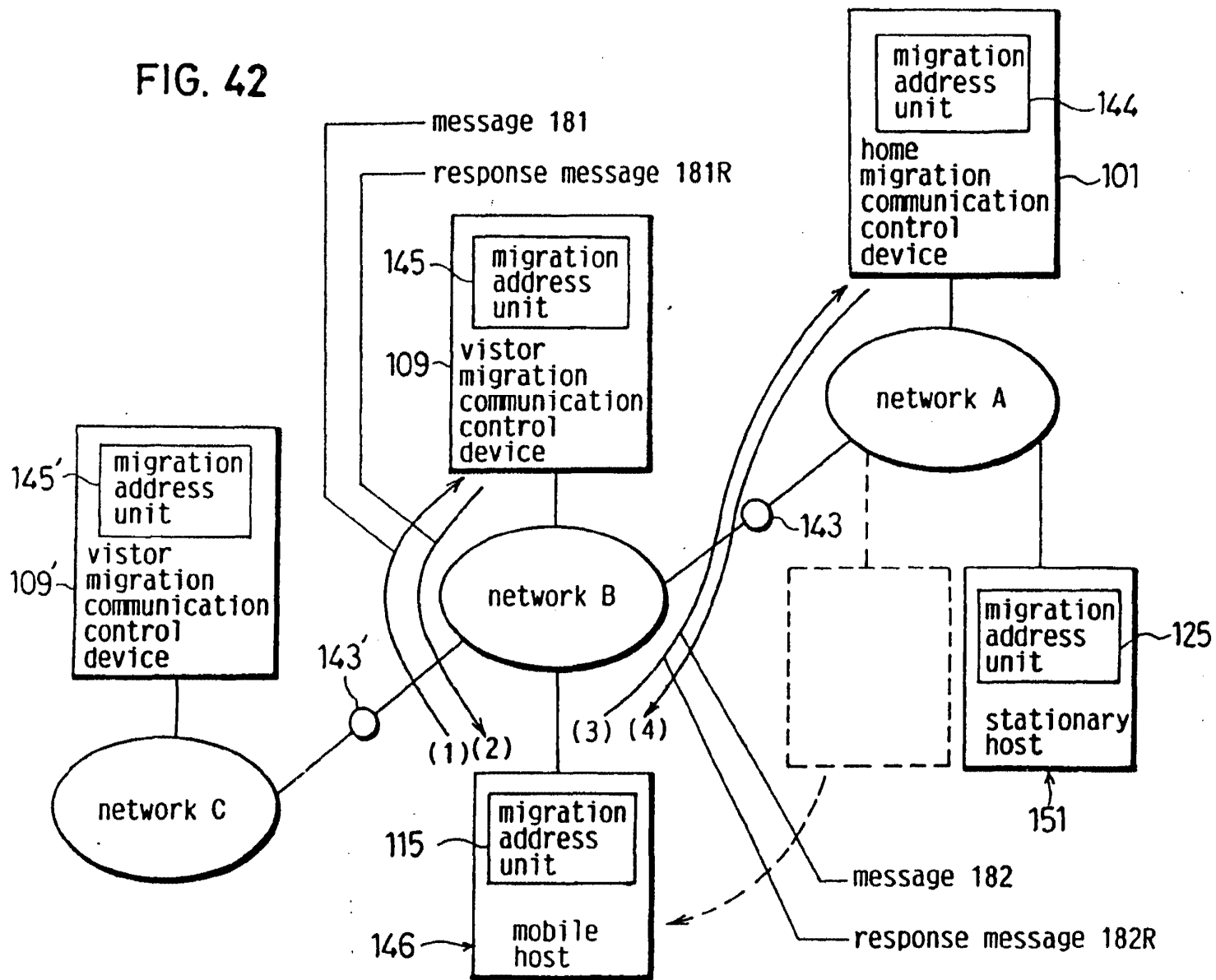


FIG. 41

address before communica- tion	address hold unit 119				home MH list hold unit 102				visitor MH list hold unit 110				visitor MH list hold unit 109'				address hold unit 128	
	$\alpha$	Aba	$\beta$	Cba	$\alpha$	$\beta$	1	Cba	$\alpha$	$\beta$	$\beta$	1	$\alpha$	$\beta$	$\beta$	-	$\alpha$	$\beta$
(1)																		
(2)																		
(3)																	$\alpha$	$\beta$
(4)																		
(5)																		



FIG. 42



EP 0 556 012 A2

FIG. 43

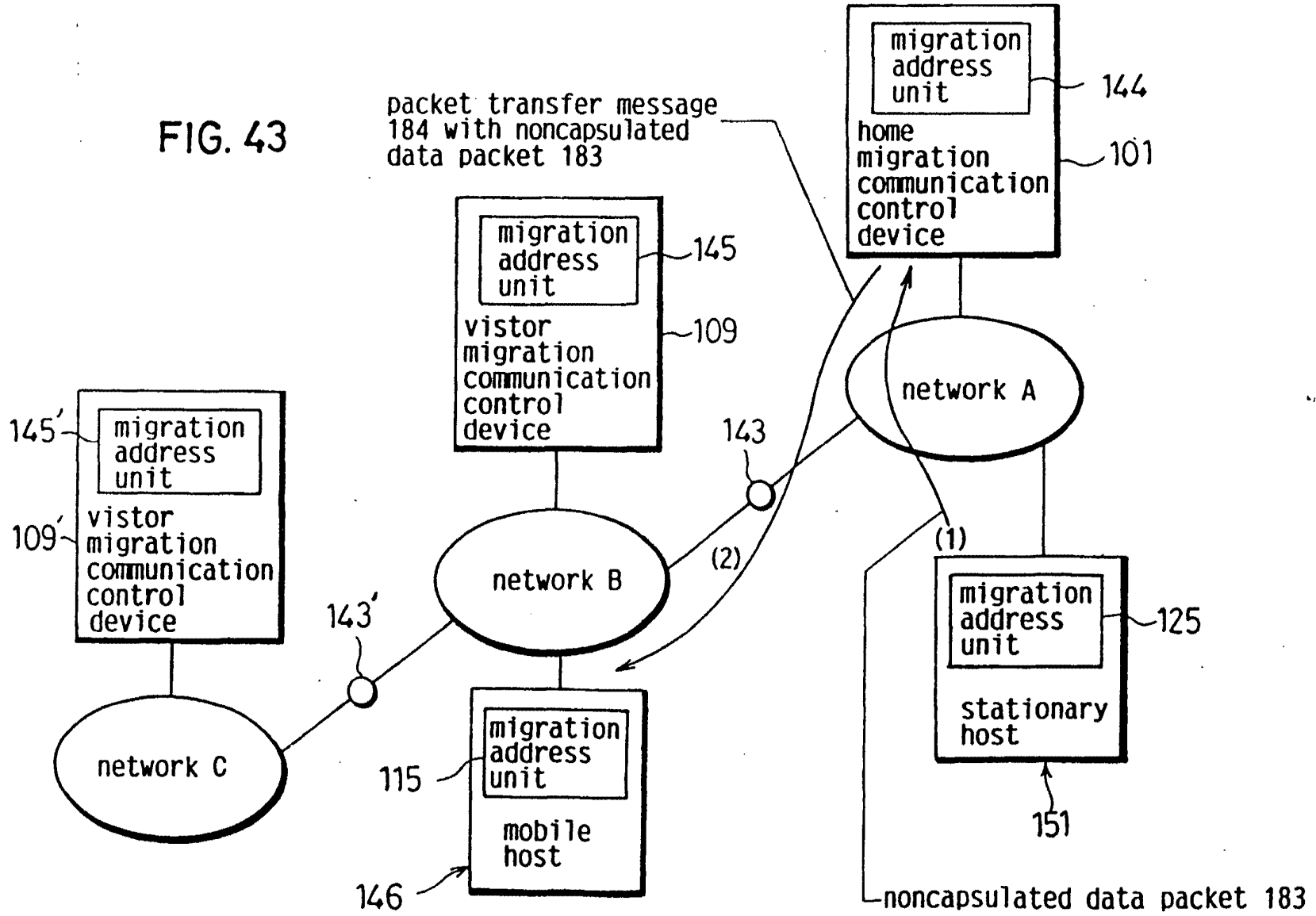


FIG. 44

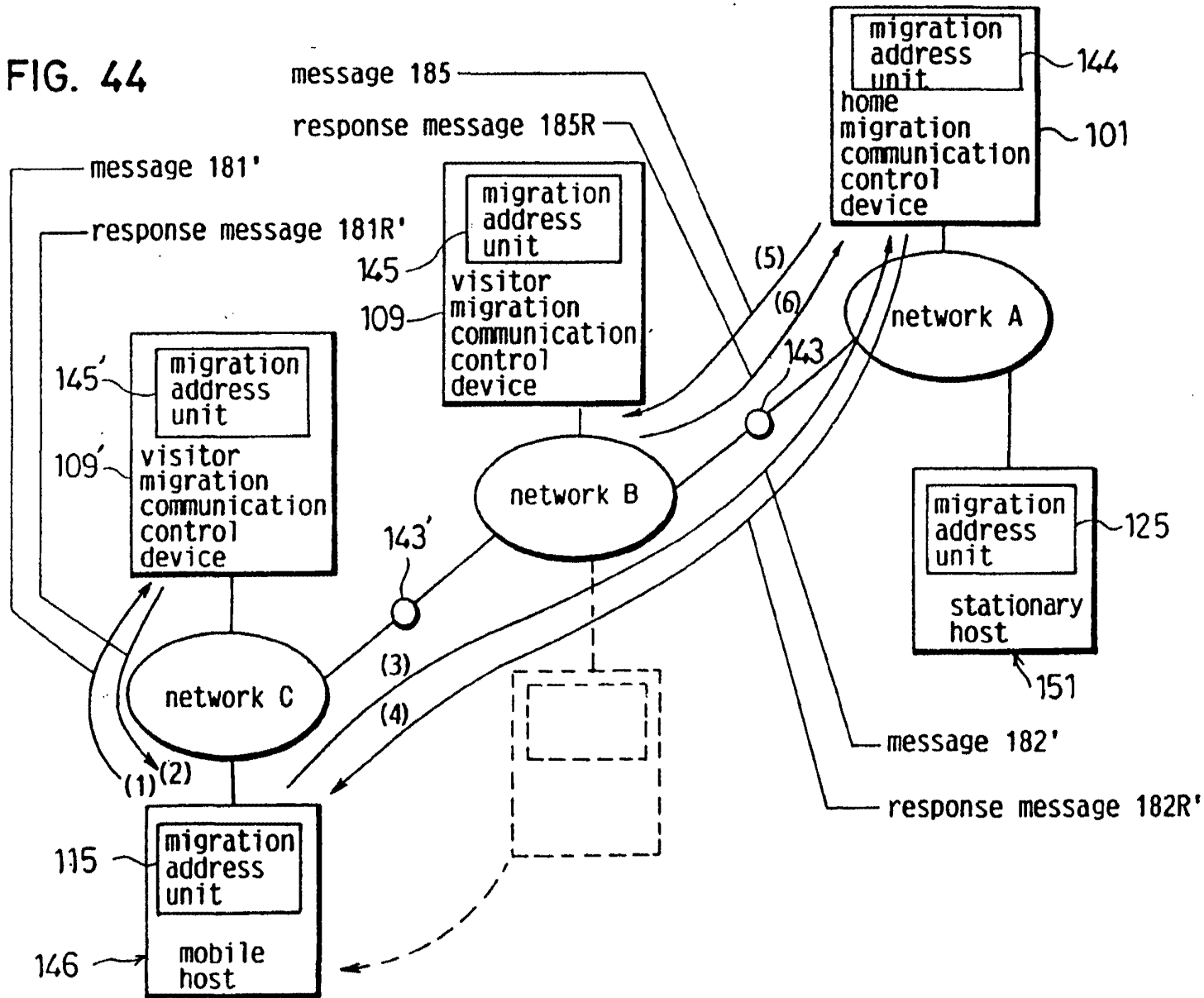
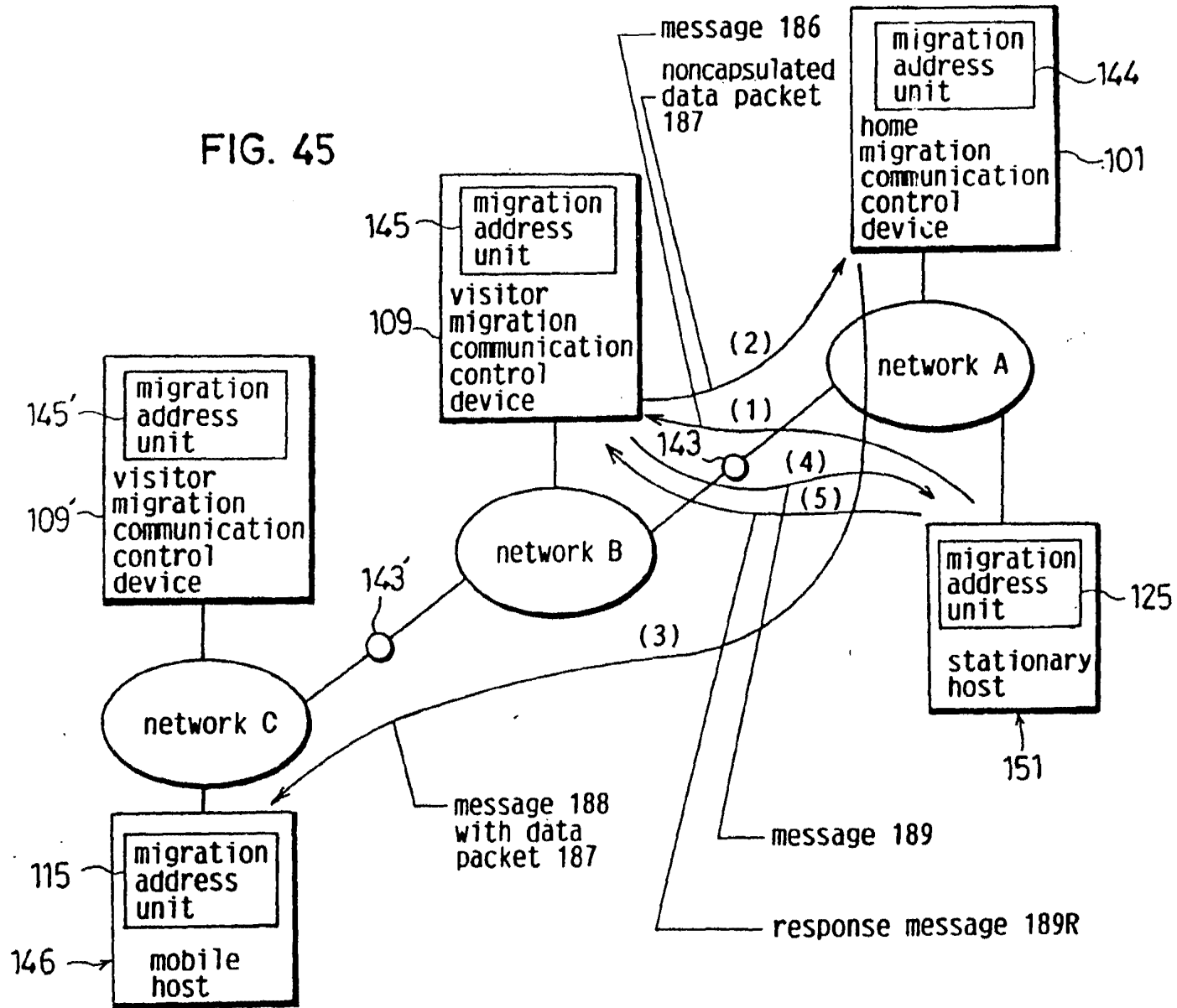


FIG. 45

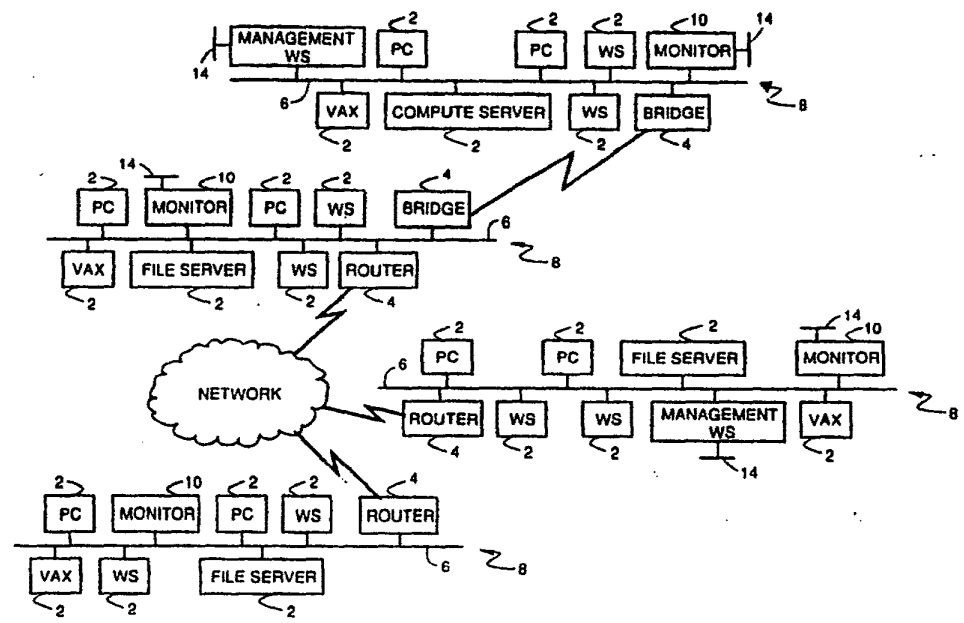


#13

INTERNATIONAL APPLICATION PUBLISHED UNDER THE PATENT COOPERATION TREATY (PCT)

<p>(51) International Patent Classification <sup>5</sup> : H04J 3/14, 3/24, H04L 12/56</p>	<p>A1</p>	<p>(11) International Publication Number: WO 92/19054 (43) International Publication Date: 29 October 1992 (29.10.92)</p>
<p>(21) International Application Number: PCT/US92/02995 (22) International Filing Date: 10 April 1992 (10.04.92) (30) Priority data: 684,695 12 April 1991 (12.04.91) US (71) Applicant: CONCORD COMMUNICATIONS, INC. [US/US]; 753 Forest Street, Marlboro, MA 01752 (US). (72) Inventors: FERDINAND, Engel ; 21 Joseph Road, Northborough, MA 01532 (US). JONES, Kendall, S. ; 90 Boulder Road, Newton Center, MA 02159 (US). ROBERTSON, Kary ; 398 North Road, Bedford, MA 01739 (US). THOMPSON, David, M. ; 5127 243rd Road, Redmond, WA 98053 (US). WHITE, Gerard ; 133 Massapoag Road, Tyngsborough, MA 01879 (US).</p>	<p>(74) Agent: PRAHL, Eric, L.; Fish &amp; Richardson, 225 Franklin Street, Boston, MA 02110-2804 (US). (81) Designated States: AT (European patent), BE (European patent), CA, CH (European patent), DE (European patent), DK (European patent), ES (European patent), FR (European patent), GB (European patent), GR (European patent), IT (European patent), JP, LU (European patent), MC (European patent), NL (European patent), SE (European patent).  <b>Published</b> <i>With international search report.</i></p>	

(54) Title: NETWORK MONITORING



(57) Abstract

Monitoring is done of communications which occur in a network of nodes (2), each communication being effected by a transmission of one or more packets among two or more communicating nodes (2), each communication complying with a predefined communication protocol selected from among protocols available in the network. The contents of packets are detected passively and in real time, communication information (130, 152, 178) associated with multiple protocols is derived from the packet contents.

**FOR THE PURPOSES OF INFORMATION ONLY**

Codes used to identify States party to the PCT on the front pages of pamphlets publishing international applications under the PCT.

AT	Austria	ES	Spain	MC	Madagascar
AU	Australia	FI	Finland	ML	Mali
BB	Barbados	FR	France	MN	Mongolia
BE	Belgium	GA	Gabon	MR	Mauritania
BF	Burkina Faso	GB	United Kingdom	MW	Malawi
BG	Bulgaria	GN	Guinea	NL	Netherlands
BJ	Benin	GR	Greece	NO	Norway
BR	Brazil	HU	Hungary	PL	Poland
CA	Canada	IT	Italy	RO	Romania
CF	Central African Republic	JP	Japan	RU	Russian Federation
CG	Congo	KP	Democratic People's Republic of Korea	SD	Sudan
CH	Switzerland	KR	Republic of Korea	SE	Sweden
CI	Côte d'Ivoire	LI	Liechtenstein	SN	Senegal
CM	Cameroon	LK	Sri Lanka	SU	Soviet Union
CS	Czechoslovakia	LU	Luxembourg	TD	Chad
DE	Germany	MC	Monaco	TG	Togo
DK	Denmark			US	United States of America

NETWORK MONITORING

Background of the Invention

The invention relates to monitoring and managing communication networks for computers.

5           Today's computer networks are large complex systems with many components from a large variety of vendors. These networks often span large geographic areas ranging from a campus-like setting to world wide networks. While the network itself can be used by many different types of  
10 organizations, the purpose of these networks is to move information between computers. Typical applications are electronic mail, transaction processing, remote database, query, and simple file transfer. Usually, the organization that has installed and is running the  
15 network needs the network to be running properly in order to operate its business. Since these networks are complex systems, there are various controls provided by the different equipment to control and manage the network. Network management is the task of planning,  
20 engineering, securing and operating a network.

To manage the network properly, the Network Manager has some obvious needs. First, the Network Manager must trouble shoot problems. As the errors develop in a running network, the Network Manager must  
25 have some tools that notify him of the errors and allow him to diagnose and repair these errors. Second, the Network Manager needs to configure the network in such a manner that the network loading characteristics provide the best service possible for the network users. To do  
30 this the Network Manager must have tools that allow him visibility into access patterns, bottlenecks and general loading. With such data, the Network Manager can reconfigure the network components for better service.

There are many different components that need to  
35 be managed in the network. These elements can be, but

- 2 -

are not limited to: routers, bridges, PC's, workstations, minicomputers, supercomputers, printers, file servers, switches and pbx's. Each component provides a protocol for reading and writing the management variables in the machine. These variables are usually defined by the component vendor and are usually referred to as a Management Information Base (MIB). There are some standard MIB's, such as the IETF (Internet Engineering Task Force) MIB I and MIB II standard definitions.

Through the reading and writing of MIB variables, software in other computers can manage or control the component. The software in the component that provides remote access to the MIB variables is usually called an agent. Thus, an individual charged with the responsibility of managing a large network often will use various tools to manipulate the MIB's of various agents on the network.

Unfortunately, the standards for accessing MIBs are not yet uniformly provided nor are the MIB definitions complete enough to manage an entire network. The Network Manager must therefore use several different types of computers to access the agents in the network. This poses a problem, since the errors occurring on the network will tend to show up in different computers and the Network Manager must therefore monitor several different screens to determine if the network is running properly. Even when the Network Manager is able to accomplish this task, the tools available are not sufficient for the Network Manager to function properly.

Furthermore, there are many errors and loadings on the network that are not reported by agents. Flow control problems, retransmissions, on-off segment loading, network capacities and utilizations are some of the types of data that are not provided by the agents.



Simple needs like charging each user for actual network usage are impossible.

Summary of the Invention

In general, in one aspect, the invention features  
5 monitoring communications which occur in a network of  
nodes, each communication being effected by a  
transmission of one or more packets among two or more  
communicating nodes, each communication complying with a  
predefined communication protocol selected from among  
10 protocols available in the network. The contents of  
packets are detected passively and in real time,  
communication information associated with multiple  
protocols is derived from the packet contents.

Preferred embodiments of the invention include the  
15 following features. The communication information  
derived from the packet contents is associated with  
multiple layers of at least one of the protocols.

In general, in another aspect, the invention  
features monitoring communication dialogs which occur in  
20 a network of nodes, each dialog being effected by a  
transmission of one or more packets among two or more  
communicating nodes, each dialog complying with a  
predefined communication protocol selected from among  
protocols available in the network. Information about  
25 the states of dialogs occurring in the network and which  
comply with different selected protocols available in the  
network is derived from the packet contents.

Preferred embodiments of the invention include the  
following features. A current state is maintained for  
30 each dialog, and the current state is updated in response  
to the detected contents of transmitted packets. For  
each dialog, a history of events is maintained based on  
information derived from the contents of packets, and the  
history of events is analyzed to derive information about  
35 the dialog. The analysis of the history includes

- 4 -

counting events and gathering statistics about events. The history is monitored for dialogs which are inactive, and dialogs which have been inactive for a predetermined period of time are purged. For example, the current  
5 state is updated to data state in response to observing the transmission of at least two data related packets from each node. Sequence numbers of data related packets stored in the history of events are analyzed and retransmissions are detected based on the sequence  
10 numbers. The the current state is updated based on each new packet associated with the dialog; if an updated current state cannot be determined, information about prior packets associated with the dialog is consulted as an aid in updating the state. The history of events may  
15 be searched to identify the initiator of a dialog.

The full set of packets associated with a dialog up to a point in time completely define a true state of the dialog at that point in time, and the step of updating the current state in response to the detected  
20 contents of transmitted packets includes generating a current state (e.g., "unknown") which may not conform to the true state. The current state may be updated to the true state based on information about prior packets transmitted in the dialog.

25 Each communication may involve multiple dialogs corresponding to a specific protocol. Each protocol layer of the communication may be parsed and analyzed to isolate each dialog and statistics may be kept for each dialog. The protocols may include a connectionless-type  
30 protocol in which the state of a dialog is implicit in transmitted packets, and the step of deriving information about the states of dialogs includes inferring the states of the dialogs from the packets. Keeping statistics for protocol layers may be temporarily suspended when parsing

and statistics gathering is not rapid enough to match the rate of packets to be parsed.

In general, in another aspect, the invention features monitoring the operation of the network with respect to specific items of performance during normal operation, generating a model of the network based on the monitoring, and setting acceptable threshold levels for the specific items of performance based on the model. In preferred embodiments, the operation of the network is monitored with respect to the specific items of performance during periods which may include abnormal operation.

In general, in another aspect, the invention features the combination of a monitor connected to the network medium for passively, and in real time, monitoring transmitted packets and storing information about dialogs associated with the packets, and a workstation for receiving the information about dialogs from the monitor and providing an interface to a user. In preferred embodiments, the workstation includes means for enabling a user to observe events of active dialogs.

In general, in another aspect, the invention features apparatus for monitoring packet communications in a network of nodes in which communications may be in accordance with multiple protocols. The apparatus includes a monitor connected to a communication medium of the network for passively, and in real time, monitoring transmitted packets of different protocols and storing information about communications associated with the packets, the communications being in accordance with different protocols, and a workstation for receiving the information about the communications from the monitor and providing an interface to a user. The monitor and the workstation include means for relaying the information about multiple protocols with respect to communication in

- 6 -

the different protocols from the monitor to the workstation in accordance with a single common network management protocol.

In general, in another aspect, the invention features diagnosing communication problems between two nodes in a network of nodes interconnected by links. The operation of the network is monitored with respect to specific items of performance during normal operation. A model of normal operation of the network is generated based on the monitoring. Acceptable threshold levels are set for the specific items of performance based on the model. The operation of the network is monitored with respect to the specific items of performance during periods which may include abnormal operation. When abnormal operation of the network with respect to communication between the two nodes is detected, the problem is diagnosed by separately analyzing the performance of each of the nodes and each of the links connecting the two nodes to isolate the abnormal operation.

In general, in another aspect, the invention features a method of timing the duration of a transaction of interest occurring in the course of communication between nodes of a network, the beginning of the transaction being defined by the sending of a first packet of a particular kind from one node to the other, and the end of the transaction being defined by the sending of another packet of a particular kind between the nodes. In the method, packets transmitted in the network are monitored passively and in real time. The beginning time of the transaction is determined based on the appearance of the first packet. A determination is made of when the other packet has been transmitted. The timing of the duration of the transaction is ended upon the appearance of the other packet.

In general, in another aspect, the invention features, tracking node address to node name mappings in a network of nodes of the kind in which each node has a possibly nonunique node name and a unique node address  
5 within the network and in which node addresses can be assigned and reassigned to node names dynamically using a name binding protocol message incorporated within a packet. In the method, packets transmitted in the network are monitored, and a table linking node names to  
10 node addresses is updated based on information contained in the name binding protocol messages in the packets.

One advantage of the invention is that it enables a network manager to passively monitor multi-protocol networks at multiple layers of the communications. In  
15 addition, it organizes and presents network performance statistics in terms of dialogs which are occurring at any desired level of the communication. This technique of organizing and displaying network performance statistics provides an effective and useful view of network  
20 performance and facilitates a quick diagnosis of network problems.

Other advantages and features will become apparent from the following description of the preferred embodiment and from the claims.

25 Description of the Preferred Embodiments

Fig. 1 is a block diagram of a network;

Fig. 2 shows the layered structure of a network communication and a protocol tree within that layered environment;

30 Fig. 3 illustrates the structure of an ethernet/IP/TCP packet;

Fig. 4 illustrates the different layers of a communication between two nodes;

Fig. 5 shows the software modules within the  
35 Monitor;

- 8 -

Fig. 6 shows the structure of the Monitor software in terms of tasks and intertask communication mechanisms;

Figs. 7a-c show the STATS data structures which store performance statistics relating to the the data  
5 link layer;

Fig. 8 is a event/state table describing the operation of the state machine for a TCP connection;

Fig. 9a is a history data structure that is identified by a pointer found in the appropriate dialog  
10 statistics data within STATS;

Fig. 9b is a record from the history table;

Fig. 10 is a flow diagram of the Look\_for\_Data\_State routine;

Fig. 11 is a flow diagram of the  
15 Look\_for\_Initiator routine that is called by the Look\_for\_Data\_State routine;

Fig. 12 is a flow diagram of the Look\_for\_Retransmission routine which is called by the  
Look\_at\_History routine;

20 Fig. 13 is a diagram of the major steps in processing a frame through the Real Time Parser (RTP);

Fig. 14 is a diagram of the major steps in the processing a statistics threshold event;

Fig. 15 is a diagram of the major steps in the  
25 processing of a database update;

Fig. 16 is a diagram of the major steps in the processing of a monitor control request;

Fig. 17 is a logical map of the network as displayed by the Management Workstation;

30 Fig. 18 is a basic summary tool display screen;

Fig. 19 is a protocol selection menu that may be invoked through the summary tool display screen;

Figs. 20a-g are examples of the statistical variables which are displayed for different protocols;

Fig. 21 is an example of information that is displayed in the dialogs panel of the summary tool display screen;

Fig. 22 is a basic data screen presenting a rate values panel, a count values panel and a protocols seen panel;

Fig. 23 is a traffic matrix screen;

Fig. 24 is a flow diagram of the algorithm for adaptively establishing network thresholds based upon actual network performance;

Fig. 25 is a simple multi-segment network;

Fig. 26 is a flow diagram of the operation of the diagnostic analyzer algorithm;

Fig. 27 is a flow diagram of the source node analyzer algorithm;

Fig. 28 is a flow diagram of the sink node analyzer algorithm;

Fig. 29 is a flow diagram of the link analysis logic;

Fig. 30 is a flow diagram of the DLL problem checking routine;

Fig. 31 is a flow diagram of the IP problem checking routine;

Fig. 32 is a flow diagram of the IP link component problem checking routine;

Fig. 33 is a flow diagram of the DLL link component problem checking routine;

Fig. 34 shows the structure of the event timing database;

Fig. 35 is a flow diagram of the operation of the event timing module (ETM) in the Network Monitor;

Fig. 36 is a network which includes an Appletalk® segment;

Fig. 37 is a Name Table that is maintained by the Address Tracking Module (ATM);

- 10 -

Fig. 38 is a flow diagram of the operation of the ATM; and

Fig. 39 is a flow diagram of the operation of the ATM.

5 Also attached hereto before the claims are the following appendices:

Appendix I identifies the SNMP MIB subset that is supported by the Monitor and the Management Workstation (2 pages);

10 Appendix II defines the extension to the standard MIB that are supported by the Monitor and the Management Workstation (25 pages);

Appendix III is a summary of the protocol variables for which the Monitor gathers statistics and a  
15 brief description of the variables, where appropriate (17 pages);

Appendix IV is a list of the Summary Tool Values Display Fields with brief descriptions (2 pages); and

20 Appendix V is a description of the actual screens for the Values Tool (34 pages).

#### Structure and Operation

##### The Network:

A typical network, such as the one shown in Fig. 1, includes at least three major components, namely,  
25 network nodes 2, network elements 4 and communication lines 6. Network nodes 2 are the individual computers on the network. They are the very reason the network exists. They include but are not limited to workstations (WS), personal computers (PC), file servers (FS), compute  
30 servers (CS) and host computers (e.g., a VAX), to name but a few. The term server is often used as though it was different from a node, but it is, in fact, just a node providing special services.

In general, network elements 4 are anything that  
35 participate in the service of providing data movement in



a network, i.e., providing the basic communications. They include, but are not limited to, LAN's, routers, bridges, gateways, multiplexors, switches and connectors. Bridges serve as connections between different network  
5 segments. They keep track of the nodes which are connected to each of the segments to which they are connected. When they see a packet on one segment that is addressed to a node on another of their segments, they grab the packet from the one segment and transfer it to  
10 the proper segment. Gateways generally provide connections between different network segments that are operating under different protocols and serve to convert communications from one protocol to the other. Nodes send packets to routers so that they may be directed over  
15 the appropriate segments to the intended destination node.

Finally, network or communication lines 6 are the components of the network which connect nodes 2 and elements 4 together so that communications between nodes 2  
20 may take place. They can be private lines, satellite lines or Public Carrier lines. They are expensive resources and are usually managed as separate entities. Often networks are organized into segments 8 that are connected by network elements 4. A segment 8 is a  
25 section of a LAN connected at a physical level (this may include repeaters). Within a segment, no protocols at layers above the physical layer are needed to enable signals from two stations on the same segment to reach each other (i.e., there are no routers, bridges,  
30 gateways...).

The Network Monitor and the Management Workstation:

In the described embodiment, there are two basic elements to the monitoring system which is to be described, namely, a Network Monitor 10 and a Management

- 12 -

Workstation 12. Both elements interact with each other over the local area network (LAN).

Network Monitor 10 (referred to hereinafter simply as Monitor 10) is the data collection module which is  
5 attached to the LAN. It is a high performance real time front end processor which collects packets on the network and performs some degree of analysis to search for actual or potential problems and to maintain statistical information for use in later analysis. In general, it  
10 performs the following functions. It operates in a promiscuous mode to capture and analyze all packets on the segment and it extracts all items of interest from the frames. It generates alarms to notify the Management Workstation of the occurrence of significant events. It  
15 receives commands from the Management Workstation, processes them appropriately and returns responses.

Management Workstation 12 is the operator interface. It collects and presents troubleshooting and performance information to the user. It is based on the  
20 SunNet Manager (SNM) product and provides a graphical network-map-based interface and sophisticated data presentation and analysis tools. It receives information from Monitor 10, stores it and displays the information in various ways. It also instructs Monitor 10 to perform  
25 certain actions. Monitor 10, in turn, sends responses and alarms to Management Workstation 12 over either the primary LAN or a backup serial link 14 using SNMP with the MIB extensions defined later.

These devices can be connected to each other over  
30 various types of networks and are not limited to connections over a local area network. As indicated in Fig. 1, there can be multiple Workstations 12 as well as multiple Monitors 10.

Before describing these components in greater  
35 detail, background information will first be reviewed

regarding communication protocols which specify how communications are conducted over the network and regarding the structure of the packets.

The Protocol Tree:

5           As shown in Fig. 2, communication over the network is organized as a series of layers or levels, each one built upon the next lower one, and each one specified by one or more protocols (represented by the boxes). Each layer is responsible for handling a different phase of  
10 the communication between nodes on the network. The protocols for each layer are defined so that the services offered by any layer are relatively independent of the services offered by the neighbors above and below.

Although the identities and number of layers may differ  
15 depending on the network (i.e., the protocol set defining communication over the network), in general, most of them share a similar structure and have features in common.

For purposes of the present description, the Open Systems Interconnection (OSI) model will be presented as  
20 representative of structured protocol architectures. The OSI model, developed by the International Organization for Standardization, includes seven layers. As indicated in Fig. 2, there is a physical layer, a data link layer (DLL), a network layer, a transport layer, a session  
25 layer, a presentation layer and an application layer, in that order. As background for what is to follow, the function of each of these layers will be briefly described.

The physical layer provides the physical medium  
30 for the data transmission. It specifies the electrical and mechanical interfaces of the network and deals with bit level detail. The data link layer is responsible for ensuring an error-free physical link between the communicating nodes. It is responsible for creating and  
35 recognizing frame boundaries (i.e., the boundaries of the

- 14 -

packets of data that are sent over the network.) The network layer determines how packets are routed within the network. The transport layer accepts data from the layer above it (i.e., the session layer), breaks the

5 packets up into smaller units, if required, and passes these to the network layer for transmission over the network. It may insure that the smaller pieces all arrive properly at the other end. The session layer is the user's interface into the network. The user must

10 interface with the session layer in order to negotiate a connection with a process in another machine. The presentation layer provides code conversion and data reformatting for the user's application. Finally, the application layer selects the overall network service for

15 the user's application.

Fig. 2 also shows the protocol tree which is implemented by the described embodiment. A protocol tree shows the protocols that apply to each layer and it identifies by the tree structure which protocols at each

20 layer can run "on top of" the protocols of the next lower layer. Though standard abbreviations are used to identify the protocols, for the convenience of the reader, the meaning of the abbreviations are as follows:

	ARP	Address Resolution Protocol
25	ETHERNET	Ethernet Data Link Control
	FTP	File Transfer Protocol
	ICMP	Internet Control Message Protocol
	IP	Internet Protocol
	LLC	802.2 Logical Link Control
30	MAC	802.3 CSMA/CD Media Access Control
	NFS	Network File System
	NSP	Name Server Protocol
	RARP	Reverse Address Resolution Protocol
	SMTP	Simple Mail Transfer Protocol
35	SNMP	Simple Network Management Protocol

TCP	Transmission Control Protocol
TFTP	Trivial File Transfer Protocol
UDP	User Datagram Protocol

Two terms are commonly used to describe the protocol  
5 tree, namely, a protocol stack and a protocol family (or  
suite). A protocol stack generally refers to the  
underlying protocols that are used when sending a message  
over a network. For example, FTP/TCP/IP/LLC is a  
protocol stack. A protocol family is a loose association  
10 of protocols which tend to be used on the same network  
(or derive from a common source). Thus, for example, the  
TCP/IP family includes IP, TCP, UDP, ARP, TELNET and FTP.  
The Decnet family includes the protocols from Digital  
Equipment Corporation. And the SNA family includes the  
15 protocols from IBM.

The Packet:

The relevant protocol stack defines the structure  
of each packet that is sent over the network. Fig. 3,  
which shows an TCP/IP packet, illustrates the typical  
20 structure of a packet. In general, each level of the  
protocol stack takes the data from the next higher level  
and adds header information to form a protocol data unit  
(PDU) which it passes to the next lower level. That is,  
as the data from the application is passed down through  
25 the protocol layers in preparation for transmission over  
the network, each layer adds its own information to the  
data passed down from above until the complete packet is  
assembled. Thus, the structure of a packet resembles  
that of an onion, with each PDU of a given layer wrapped  
30 within the PDU of the adjacent lower level.

At the ethernet level, the PDU includes a  
destination address (DEST MAC ADDR), a source address  
(SRC MAC ADDR), a type (TYPE) identifying the protocol  
which is running on top of this layer, and a DATA field  
35 for the PDU from the IP layer.

- 16 -

Like the ethernet packet, the PDU for the IP layer includes an IP header plus a DATA field. The IP header includes a type field (TYPE) for indicating the type of service, a length field (LGTH) for specifying the total  
5 length of the PDU, an identification field (ID), a protocol field (PROT) for identifying the protocol which is running on top of the IP layer (in this case, TCP), a source address field (SRC ADDR) for specifying the IP  
10 ADDR) for specifying the IP address of the destination node, and a DATA field.

The PDU built by the TCP protocol also consists of a header and the data passed down from the next higher layer. In this case the header includes a source port  
15 field (SRC PORT) for specifying the port number of the sender, a destination port field (DEST PORT) for specifying the port number of the destination, a sequence number field (SEQ NO.) for specifying the sequence number of the data that is being sent in this packet, and an  
20 acknowledgment number field (ACK NO.) for specifying the number of the acknowledgment being returned. It also includes bits which identify the packet type, namely, an acknowledgment bit (ACK), a reset connection bit (RST), a synchronize bit (SYN), and a no more data from sender bit  
25 (FIN). There is also a window size field (WINDOW) for specifying the size of the window being used.

The Concept of a Dialog:

The concept of a dialog is used throughout the following description. As will become apparent, it is a  
30 concept which provides a useful way of conceptualizing, organizing and displaying information about the performance of a network - for any protocol and for any layer of the multi-level protocol stack.

As noted above, the basic unit of information in  
35 communication is a packet. A packet conveys meaning

between the sender and the receiver and is part of a larger framework of packet exchanges. The larger exchange is called a dialog within the context of this document. That is, a dialog is a communication between a  
5 sender and a receiver, which is composed of one or more packets being transmitted between the two. There can be multiple senders and receivers which can change roles. In fact, most dialogs involve exchanges in both directions.

10 Stated another way, a dialog is the exchange of messages and the associated meaning and state that is inherent in any particular exchange at any layer. It refers to the exchange between the peer entities (hardware or software) in any communication. In those  
15 situations where there is a layering of protocols, any particular message exchange could be viewed as belonging to multiple dialogs. For example, in Fig. 4 Nodes A and B are exchanging packets and are engaged in multiple dialogs. Layer 1 in Node A has a dialog with Layer 1 in  
20 Node B. For this example, one could state that this is the data link layer and the nature of the dialog deals with the message length, number of messages, errors and perhaps the guarantee of the delivery. Simultaneously, Layer n of Node A is having a dialog with Layer n of node  
25 B. For the sake of the example, one could state that this is an application layer dialog which deals with virtual terminal connections and response rates. One can also assume that all of the other layers (2 through n-1) are also having simultaneous dialogs.

30 In some protocols there are explicit primitives that deal with the dialog and they are generally referred to as connections or virtual circuits. However, dialogs exist even in stateless and connectionless protocols. Two more examples will be described to help clarify the  
35 concept further, one dealing with a connection oriented

- 18 -

protocol and the other dealing with a connectionless protocol.

In a typical connection oriented protocol, Node A sends a connection request (CR) message to Node B. The  
5 CR is an explicit request to form a connection. This is the start of a particular dialog, which is no different from the start of the connection. Nodes A and B could have other dialogs active simultaneously with this particular dialog. Each dialog is seen as unique. A  
10 connection is a particular type of dialog.

In a typical connectionless protocol, Node A sends Node B a message that is a datagram which has no connection paradigm, in fact, neither do the protocol(s) at higher layers. The application protocol designates  
15 this as a request to initiate some action. For example, a file server protocol such as Sun Microsystems' Network File System (NFS) could make a mount request. A dialog comes into existence once the communication between Nodes A and B has begun. It is possible to determine that  
20 communication has occurred and to determine the actions being requested. If in fact there exists more than one communication thread between Nodes A and B, then these would represent separate, different dialogs.

Inside the Network Monitor:

25 Monitor 10 includes a MIPS R3000 general purpose microprocessor (from MIPS Computer Systems, Inc.) running at 25 MHz. It is capable of providing 20 mips processing power. Monitor 10 also includes a 64Kbyte instruction cache and a 64Kbyte data cache, implemented by SRAM.

30 The major software modules of Monitor 10 are implemented as a mixture of tasks and subroutine libraries as shown in Fig. 5. It is organized this way so as to minimise the context switching overhead incurred during critical processing sequences. There is NO  
35 PREEMPTION of any module in the monitor subsystem. Each



module is cognizant of the fact that it should return control to the kernel in order to let other tasks run. Since the monitor subsystem is a closed environment, the software is aware of real time constraints.

5           Among the major modules which make up Monitor 10 is a real time kernel 20, a boot/load module 22, a driver 24, a test module 26, an SNMP Agent 28, a Timer module 30, a real time parser (RTP) 32, a Message Transport Module (MTM) 34, a statistics database (STATS) 36, an  
10 Event Manager (EM) 38, an Event Timing Module (ETM) 40 and a control module 42. Each of these will now be described in greater detail.

          Real Time Kernel 20 takes care of the general housekeeping activities in Monitor 10. It is responsible  
15 for scheduling, handling intertask communications via queues, managing a potentially large number of timers, manipulating linked lists, and handling simple memory management.

          Boot/Load Module 22, which is FProm based, enables  
20 Monitor 10 to start itself when the power is turned on in the box. It initializes functions such as diagnostics, and environmental initialization and it initiates down loading of the Network Monitor Software including program and configuration files from the Management Workstation.  
25 Boot/load module 22 is also responsible for reloading program and/or configuration data following internal error detection or on command from the Management Workstation. To accomplish down loading, boot/load module 22 uses the Trivial File Transfer Protocol (TFTP).  
30 The protocol stack used for loading is TFTP/UDP/IP/ethernet over the LAN and TFTP/UDP/IP/SLIP over the serial line.

          Device Driver 24 manages the network controller hardware so that Monitor 10 is able to read and write  
35 packets from the network and it manages the serial

- 20 -

interface. It does so both for the purposes of monitoring traffic (promiscuous mode) and for the purposes of communicating with the Management Workstation and other devices on the network. The communication  
5 occurs through the network controller hardware of the physical network (e.g. Ethernet). The drivers for the LAN controller and serial line interface are used by the boot load module and the MTM. They provide access to the chips and isolate higher layers from the hardware  
10 specifics.

Test module 26 performs and reports results of physical layer tests (TDR, connectivity,...) under control of the Management Workstation. It provides traffic load information in response to user requests  
15 identifying the particular traffic data of interest. The load information is reported either as a percent of available bandwidth or as frame size(s) plus rate.

SNMP Agent 28 translates requests and information into the network management protocol being used to  
20 communicate with the Management Workstation, e.g., the Simple Network Management Protocol (SNMP).

Control Module 42 coordinates access to monitor control variables and performs actions necessary when these are altered. Among the monitor control variables  
25 which it handles are the following:

set reset monitor - transfer control to reset logic;

set time of day - modify monitor hardware clock and generate response to Management Workstation;

30 get time of day - read monitor hardware clock and generate response to Workstation;

set trap permit - send trap control ITM to EM and  
generate response to Workstation;

get trap permit - generate response to  
Workstation;

5 Control module 42 also updates parse control records  
within STATS when invoked by the RTP (to be described) or  
during overload conditions so that higher layers of  
parsing are dropped until the overload situation is  
resolved. When overload is over it restores full  
10 parsing.

Timer 30 is invoked periodically to perform  
general housekeeping functions. It pulses the watchdog  
timer at appropriate intervals. It also takes care of  
internal time stamping and kicking off routines like the  
15 EM routine which periodically recalculates certain  
numbers within the statistical database (i.e., STATS).

Real Time Parser (RTP) 32 sees all frames on the  
network and it determines which protocols are being used  
and interprets the frames. The RTP includes a protocol  
20 parser and a state machine. The protocol parser parses a  
received frame in the "classical" manner, layer-by-layer,  
lowest layer first. The parsing is performed such that  
the statistical objects in STATS (i.e., the network  
parameters for which performance data is kept) are  
25 maintained. Which layers are to have statistics stored  
for them is determined by a parse control record that is  
stored in STATS (to be described later). As each layer  
is parsed, the RTP invokes the appropriate functions in  
the statistics module (STATS) to update those statistical  
30 objects which must be changed.

The state machine within RTP 32 is responsible for  
tracking state as appropriate to protocols and  
connections. It is responsible for maintaining and  
updating the connection oriented statistical elements in

- 22 -

STATS. In order to track connection states and events, the RTP invokes a routine within the state machine. This routine determines the state of a connection based on past observed frames and keeps track of sequence numbers. 5 It is the routine that determines if a connection is in data transfer state and if a retransmission has occurred. The objectives of the state machine are to keep a brief history of events, state transitions, and sequence numbers per connection; to detect data transfer state so 10 that sequence tracking can begin; and to count inconsistencies but still maintain tracking while falling into an appropriate state (e.g. unknown).

RTP 32 also performs overload control by determining the number of frames awaiting processing and 15 invoking control module 42 to update the parse control records so as to reduce the parsing depth when the number becomes too large.

Statistics Module (STATS) 36 is where Monitor 10 keeps information about the statistical objects it is 20 charged with monitoring. A statistical object represents a network parameter for which performance information is gathered. This information is contained in an extended MIB (Management Information Base), which is updated by RTP 32 and EM 38.

25 STATS updates statistical objects in response to RTP invocation. There are at least four statistical object classes, namely, counters, timers, percentages (%), and meters. Each statistical object is implemented as appropriate to the object class to which it belongs. 30 That is, each statistical object behaves such that when invoked by RTP 32 it updates and then generates an alarm if its value meets a preset threshold. (Meets means that for a high threshold the value is equal to or greater than the threshold and for a low threshold the value is

equal to or less than the threshold. Note that a single object may have both high and low thresholds.)

STATS 36 is responsible for the maintenance and initial analysis of the database. This includes  
5 coordinating access to the database variables, ensuring appropriate interlocks are applied and generating alarms when thresholds are crossed. Only STATS 36 is aware of the internal structure of the database, the rest of the system is not.

10 STATS 36 is also responsible for tracking events of interest in the form of various statistical reductions. Examples are counters, rate meters, and rate of change of rate meters. It initiates events based on particular statistics reaching configured limits, i.e.,  
15 thresholds. The events are passed to the EM which sends a trap (i.e., an alarm) to the Management Workstation. The statistics within STATS 36 are readable from the Management Workstation on request.

STATS performs lookup on all addressing fields.  
20 It assigns new data structures to address field values not currently present. It performs any hashing for fast access to the database. More details will be presented later in this document.

Event Manager (EM) 38 extracts statistics from  
25 STATS and formats it in ways that allow the Workstation to understand it. It also examines the various statistics to see if their behavior warrants a notification to the Management Workstation. If so, it uses the SNMP Agent software to initiate such  
30 notifications.

If the Workstation asks for data, EM 38 gets the data from STATS and sends it to the Workstation. It also performs some level of analysis for statistical, accounting and alarm filtering and decides on further  
35 action (e.g. delivery to the Management Workstation).

- 24 -

EM 38 is also responsible for controlling the delivery of events to the Management Workstation, e.g., it performs event filtering. The action to be taken on receipt of an event (e.g. threshold exceeded in STATS) is specified by  
5 the event action associated with the threshold. The event is used as an index to select the defined action (e.g. report to Workstation, run local routine xxxx, ignore). The action can be modified by commands from the Management Workstation (e.g., turn off an alarm) or by  
10 the control module in an overload situation. An update to the event action, however, does not affect events previously processed even if they are still waiting for transmission to the Management Workstation. Discarded events are counted as such by EM 38.

15 EM 38 also implements a throttle mechanism to limit the rate of delivery of alarms to the console based on configured limits. This prevents the rapid generation of multiple alarms. In essence, Monitor 10 is given a maximum frequency at which alarms may be sent to the  
20 Workstation. Although alarms in excess of the maximum frequency are discarded, a count is kept of the number of alarms that were discarded.

EM 38 invokes routines from the statistics module (STATS) to perform periodic updates such as rate  
25 calculations and threshold checks. It calculates time averages, e.g., average traffic by source stations, destination stations. EM 38 requests for access to monitor control variables are passed to the control module.

30 EM 38 checks whether asynchronous traps (i.e., alarms) to the Workstation are permitted before generating any.

EM 38 receives database update requests from the Management Workstation and invokes the statistics module  
35 (STATS) to process these.

Message Transport Module (MTM) 34, which is DRAM based, has two distinct but closely related functions. First, it is responsible for the conversion of Workstation commands and responses from the internal  
5 format used within Monitor 10 to the format used to communicate over the network. It isolates the rest of the system from the protocol used to communicate within Management Workstation. It translates between the internal representation of data and ASN.1 used for SNMP.  
10 It performs initial decoding of Workstation requests and directs the requests to appropriate modules for processing. It implements SNMP/UDP/IP/LLC or ETHERNET protocols for LAN and SNMP/UDP/IP/SLIP protocols for serial line. It receives network management commands  
15 from the Management Workstation and delivers these to the appropriate module for action. Alarms and responses destined for the Workstation are also directed via this module.

Second, MTM 34 is responsible for the delivery and  
20 reception of data to and from the Management Workstation using the protocol appropriate to the network. Primary and backup communication paths are provided transparently to the rest of the monitor modules (e.g. LAN and dial up link). It is capable of full duplex delivery of messages  
25 between the console and monitoring module. The messages carry event, configuration, test and statistics data.

Event Timing Module (ETM) 40 keeps track of the start time and end times of user specified transactions over the network. In essence, this module monitors the  
30 responsiveness of the network at any protocol or layer specified by the user.

Address Tracking Module 42 keeps track of the node name to node address bindings on networks which implement dynamic node addressing protocols.

- 26 -

Memory management for Monitor 10 is handled in accordance with following guidelines. The available memory is divided into four blocks during system initialization. One block includes receive frame 5 buffers. They are used for receiving LAN traffic and for receiving secondary link traffic. These are organized as linked lists of fixed sized buffers. A second block includes system control message blocks. They are used for intertask messages within Monitor 10 and are 10 organized as a linked list of free blocks and multiple linked lists of in process intertask messages. A third block includes transmit buffers. They are used for creation and transmission of workstation alarms and responses and are organized as a linked list of fixed 15 sized buffers. A fourth block is the statistics. This is allocated as a fixed size area at system initialization and managed by the statistics module during system operation.

#### Task Structure of Monitor;

20 The structure of the Monitor in terms of tasks and intertask messages is shown in Fig. 6. The rectangular blocks represent interrupt service routines, the ovals represent tasks and the circles represent input queues.

Each task in the system has a single input queue 25 which it uses to receive all input. All inter-process communications take place via messages placed onto the input queue of the destination task. Each task waits on a (well known) input queue and processes events or inter-task messages (i.e., ITM's) as they are received. Each 30 task returns to the kernel within an appropriate time period defined for each task (e.g. after processing a fixed number of events).

Interrupt service routines (ISR's) run on receipt of hardware generated interrupts. They invoke task level



processing by sending an ITM to the input queue of the appropriate task.

The kernel scheduler acts as the base loop of the system and calls any runnable tasks as subroutines. The  
5 determination of whether a task is runnable is made from the input queue, i.e., if this has an entry the task has work to perform. The scheduler scans the input queues for each task in a round robin fashion and invokes a task with input pending. Each task processes items from its  
10 input queue and returns to the scheduler within a defined period. The scheduler then continues the scan cycle of the input queues. This avoids any task locking out others by processing a continuously busy input queue. A task may be given an effectively higher priority by  
15 providing it with multiple entries in the scan table.

Database accesses are generally performed using access routines. This hides the internal structure of the database from other modules and also ensures that appropriate interlocks are applied to shared data.

20 The EM processes a single event from the input queue and then returns to the scheduler.

The MTM Xmit task processes a single event from its input queue and then returns control to the scheduler. The MTM Recv task processes events from the  
25 input queue until it is empty or a defined number (e.g. 10) events have been processed and then returns control to the scheduler.

The timer task processes a single event from the input queue and then returns control to the scheduler.

30 RTP continues to process frames until the input queue is empty or it has processed a defined number (e.g. 10) frames. It then returns to the scheduler.

The following sections contain a more detailed description of some of the above-identified software  
35 modules.

- 28 -

The Statistics Module (STATS):

The functions of the statistics module are:

- \* to define statistics records;
- \* to allocate and initialize statistics records;
- 5 \* to provide routines to lookup statistics records,  
e.g. lookup\_id\_addr;
- \* to provide routines to manipulate the statistics  
within the records, e.g. stats\_age, stats\_incr and  
stats\_rate;
- 10 \* to provide routines to free statistics records,  
e.g. stats\_allocate and stats\_deallocate

It provides these services to the Real Time Parser (RTP) module and to the Event Manager (EM) module.

STATS defines the database and it contains  
15 subroutines for updating the statistics which it keeps.

STATS contains the type definitions for all  
statistics records (e.g. DLL, IP, TCP statistics). It  
provides an initialization routine whose major function  
is to allocate statistics records at startup from  
20 cacheable memory. It provides lookup routines in order  
to get at the statistics. Each type of statistics record  
has its own lookup routine (e.g. lookup\_ip\_address) which  
returns a pointer to a statistics record of the  
appropriate type or NULL.

25 As a received frame is being parsed, statistics  
within statistics records need to be manipulated (e.g.  
incremented) to record relevant information about the  
frame. STATS provides the routines to manipulate those  
statistics. For example, there is a routine to update  
30 counters. After the counter is incremented/decremented  
and if there is a non-zero threshold associated with the  
counter, the internal routine compares its value to the  
threshold. If the threshold has been exceeded, the Event  
Manager is signaled in order to send a trap to the  
35 Workstation. Besides manipulating statistics, these

routines, if necessary, signal the Event Manager via an Intertask Message (ITM) to send a trap to the Management Workstation.

The following is an example of some of the  
5 statistics records that are kept in STATS.

- o monitor statistics
- o mac statistics for segment
- o llc statistics for segment
- o statistics per ethernet/lsap type for segment
- 10 o ip statistics for segment
- o icmp statistics for segment
- o tcp statistics for segment
- o udp statistics for segment
- o nfs statistics for segment
- 15 o ftp control statistics for segment
- o ftp data statistics for segment
- o telnet statistics for segment
- o smtp statistics for segment
- o arp statistics for segment
  
- 20 o statistics per mac address
- o statistics per ethernet type/lasp per mac address
- o statistics per ip address (includes icmp)
- o statistics per tcp socket
- 25 o statistics per udp socket
- o statistics per nfs socket
- o statistics per ftp control socket
- o statistics per ftp data socket
- o statistics per telnet socket
- 30 o statistics per smtp socket
- o arp statistics per ip address
  
- o statistics per mac address pair
- o statistics per ip pair (includes icmp)

- 30 -

- o statistics per tcp connection
  - o statistics per udp pair
  - o statistics per nfs pair
  - o statistics per ftp control connection
  - 5 o statistics per ftp data connection
  - o statistics per telnet connection
  - o statistics per smtp connection
- o connection histories per udp and tcp socket

All statistics are organized similarly across protocol  
10 types. The details of the data structures for the DLL  
level are presented later.

As noted earlier, there are four statistical  
object classes (i.e., variables), namely, counts, rates,  
percentages (%), and meters. They are defined and  
15 implemented as follows.

A count is a continuously incrementing variable  
which rolls around to 0 on overflow. It may be reset on  
command from the user (or from software). A threshold  
may be applied to the count and will cause an alarm when  
20 the threshold count is reached. The threshold count  
fires each time the counter increments past the threshold  
value. For example, if the threshold is set to 5, alarms  
are generated when the count is 5, 10, 15,...

A rate is essentially a first derivative of a  
25 count variable. The rate is calculated at a period  
appropriate to the variable. For each rate variable, a  
minimum, maximum and average value is maintained.  
Thresholds may be set on high values of the rate. The  
maximums and minimums may be reset on command. The  
30 threshold event is triggered each time the rate  
calculated is in the threshold region.

As commonly used, the % is calculated at a period  
appropriate to the variable. For each % variable a

minimum, maximum and average value is maintained. A threshold may be set on high values of the %. The threshold event is triggered each time the % calculated is in the threshold region.

5           Finally, a meter is a variable which may take any discrete value within a defined range. The current value has no correlation to past or future values. A threshold may be set on a maximum and/or minimum value for a meter.

10           The rate and % fields of network event variables are updated differently than counter or meter fields in that they are calculated at fixed intervals rather than on receipt of data from the network.

15           Structures for statistics kept on a per address or per address pair basis are allocated at initialization time. There are several sizes for these structures. Structures of the same size are linked together in a free pool. As a new structure is needed, it is obtained from a free queue, initialized, and linked into an active list. Active lists are kept on a per statistics type  
20 basis.

25           As an address or address pair (e.g. mac, ip, tcp...) is seen, RTP code calls an appropriate lookup routine. The lookup routine scans active statistics structures to see if a structure has already been allocated for the statistics. Hashing algorithms are used in order to provide for efficient lookup. If no structure has been allocated, the lookup routine examines the appropriate parse control records to determine whether statistics should be kept, and, if so, it  
30 allocates a structure of the appropriate size, initializes it and links it into an active list.

          Either the address of a structure or a NULL is returned by these routines. If NULL is returned, the RTP does not stop parsing, but it will not be allowed to

- 32 -

store the statistics for which the structure was requested.

The RTP updates statistics within the data base as it runs. This is done via macros defined for the RTP.

- 5 The macros call on internal routines which know how to manipulate the relevant statistic. If the pointer to the statistics structure is NULL, the internal routine will not be invoked.

The EM causes rates to be calculated. The STATS  
10 module supplies routines (e.g. stats\_rate) which must be called by the EM in order to perform the rate calculations. It also calls subroutines to reformat the data in the database in order to present it to the Workstation (i.e., in response to a get from the  
15 Workstation).

The calculation algorithms for the rate and % fields of network event variables are as follows.

The following rates are calculated in units per second, at the indicated (approximate) intervals:

- 20 1. 10 second intervals:  
e.g. DLL frame, byte, ethernet, 802.3, broadcast, multicast rates
2. 60 second intervals  
e.g., all DLL error, ethertype/dsap rates
- 25 all IP rates.  
TCP packets, bytes, errors, retransmitted packets, retransmitted bytes, acks, rstts  
UDP packet, error, byte rates  
FTP file transfer, byte transfer, error rates

30 For these rates, the new average replaces the previous value directly. Maximum and minimum values are retained until reset by the user.

The following rates are calculated in units per hour at the indicated time intervals:

- 35 1. 15 minute interval.

e.g., TCP - connection rate  
Telnet connection rate  
FTP session rate

The hourly rate is calculated from a sum of the  
5 last twelve 5 minute readings, as obtained from the  
buckets for the pertinent parameter. Each new reading  
replaces the oldest of the twelve values maintained.  
Maximum and minimum values are retained until reset by  
the user.

10 There are a number of other internal routines in  
STATS. For example, all statistical data collected by  
the Monitor is subject to age out. Thus, if no activity  
is seen for an address (or address pair) in the time  
period defined for age out, then the data is discarded  
15 and the space reclaimed so that it may be recycled. In  
this manner, the Monitor is able to use the memory for  
active elements rather than stale data. The user can  
select the age out times for the different components.  
The EM periodically kicks off the aging mechanism to  
20 perform this recycling of resources. STATS provides the  
routines which the EM calls, e.g. stats\_age.

There are also routines in STATS to allocate and  
de-allocate Statistics, e.g., stats\_allocate and  
stats\_de-allocate. The allocate routine is called when  
25 stations and dialogs are picked up by the Network  
Monitor. The de-allocate routine is called by the aging  
routines when a structure is to be recycled.

#### The Data Structures in STATS

The general structure of the database within STATS  
30 is illustrated by Figs. 7a-c, which shows information  
that is maintained for the Data Link Layer (DLL) and its  
organization. A set of data structures is kept for each  
address associated with the layer. In this case there  
are three relevant addresses, namely a segment address,  
35 indicating which segment the node is on, a MAC address

- 34 -

for the node on the segment, and an address which identifies the dialog occurring over that layer. The dialog address is the combination of the MAC addresses for the two nodes which make up the dialog. Thus, the overall data structure has three identifiable components: a segment address data structure (see Fig. 7a), a MAC address data structure (see Fig. 7b) and a dialog data structure (see Fig. 7c).

The segment address structure includes a doubly linked list 102 of segment address records 104, each one for a different segment address. Each segment address record 104 contains a forward and backward link (field 106) for forward and backward pointers to neighboring records and a hash link (field 108). In other words, the segment address records are accessed by either walking down the doubly linked list or by using a hashing mechanism to generate a pointer into the doubly linked list to the first record of a smaller hash linked list. Each record also contains the address of the segment (field 110) and a set of fields for other information. Among these are a flags field 112, a type field 114, a parse\_control field 116, and an EM\_control field 118. Flags field 112 contains a bit which indicates whether the identified address corresponds to the address of another Network Monitor. This field only has meaning in the MAC address record and not in the segment or dialog address record. Type field 114 identifies the MIB group which applies to this address. Parse control field 116 is a bit mask which indicates what subgroups of statistics from the identified MIB group are maintained, if any. Flags field 112, type field 114 and parse control field 116 make up what is referred to as the parse control record for this MAC address. The Network Monitor uses a default value for parse control field 116 upon initialization or whenever a new node is detected.



The default value turns off all statistics gathering. The statistics gathering for any particular address may subsequently be turned on by the Workstation through a Network Monitor control command that sets the appropriate 5 bits of the parse control field to one.

EM\_control field 118 identifies the subgroups of statistics within the MIB group that have changed since the EM last serviced the database to update rates and other variables. This field is used by the EM to 10 identify those parts of STATS which must be updated or for which recalculations must be performed when the EM next services STAT.

Each segment address record 104 also contains three fields for time related information. There is a 15 start\_time field 120 for the time that is used to perform some of the rate calculations for the underlying statistics; a first\_seen field 122 for the time at which the Network Monitor first saw the communication; and a last\_seen field 124 for the time at which the last 20 communication was seen. The last\_seen time is used to age out the data structure if no activity is seen on the segment after a preselected period of time elapses. The first\_seen time is a statistic which may be of interest to the network manager and is thus retrievable by the 25 Management Workstation for display.

Finally, each segment address record includes a stats\_pointer field 126 for a pointer to a DLL segment statistics data structure 130 which contains all of the statistics that are maintained for the segment address. 30 If the bits in parse\_control field 116 are all set to off, indicating that no statistics are to be maintained for the address, then the pointer in stats\_pointer field 126 is a null pointer.

The list of events shown in data structure 130 of 35 Fig. 7a illustrates the type of data that is collected

- 36 -

for this address when the parse control field bits are set to on. Some of the entries in DLL segment statistics data structure 130 are pointers to buckets for historical data. In the case where buckets are maintained, there  
5 are twelve buckets each of which represents a time period of five minutes duration and each of which generally contains two items of information, namely, a count for the corresponding five minute time period and a MAX rate for that time period. MAX rate records any spikes which  
10 have occurred during the period and which the user may not have observed because he was not viewing that particular statistic at the time.

At the end of DLL segment statistics data structure 130, there is a protocol\_Q pointer 132 to a  
15 linked list 134 of protocol statistics records 136 identifying all of the protocols which have been detected running on top of the DLL layer for the segment. Each record 136 includes a link 138 to the next record in the list, the identity of the protocol (field 140), a frames  
20 count for the number of frames detected for the identified protocol (field 142); and a frame rate (field 144).

The MAC address data structure is organized in a similar manner to that of the segment data structure (see  
25 Fig. 7b). There is a doubly linked list 146 of MAC address records 148, each of which contains the same type of information as is stored in DLL segment address records 104. A pointer 150 at the end of each MAC  
30 address record 148 points to a DLL address statistics data structure 152, which like the DLL segment address data structure 130, contains fields for all of the statistics that are gathered for that DLL MAC address. Examples of the particular statistics are shown in Fig. 7b.

At the end of DLL address statistics data structure 152, there are two pointer fields 152 and 154, one for a pointer to a record 158 in a dialog link queue 160, and the other for a pointer to a linked list 162 of 5 protocol statistics records 164. Each dialog link queue entry 158 contains a pointer to the next entry (field 168) in the queue and it contains a dialog\_addr pointer 170 which points to an entry in the DLL dialog queue which involves the MAC address. (see Fig. 7c). Protocol 10 statistics records 164 have the same structure and contain the same categories of information as their counterparts hanging off of DLL segment statistics data structure 130.

The above-described design is repeated in the DLL 15 dialog data structures. That is, dialog record 172 includes the same categories of information as its counterpart in the DLL segment address data structure and the MAC address data structure. The address field 174 contains the addresses of both ends of the dialog 20 concatenated together to form a single address. The first and second addresses within the single address are arbitrarily designated nodes 1 and 2, respectively. In the stats\_pointer field 176 there is a pointer to a dialog statistics data structure 178 containing the 25 relevant statistics for the dialog. The entries in the first two fields in this data structure (i.e., fields 180 and 182) are designated protocol entries and protocols. Protocol entries is the number of different protocols which have been seen between the two MAC addresses. The 30 protocols that have been seen are enumerated in the protocols field 182.

DLL dialog statistics data structure 178, illustrated by Fig. 7c, includes several additional fields of information which only appear in these 35 structures for dialogs for which state information can be

- 38 -

kept (e.g. TCP connection). The additional fields identify the transport protocol (e.g., TCP) (field 184) and the application which is running on top of that protocol (field 186). They also include the identity of the initiator of the connection (field 188), the state of the connection (field 190) and the reason that the connection was closed, when it is closed (field 192). Finally, they also include a state\_pointer (field 194) which points to a history data structure that will be described in greater detail later. Suffice it to say, that the history data structure contains a short history of events and states for each end of the dialog. The state machine uses the information contained in the history data structure to loosely determine what the state of each of the end nodes is throughout the course of the connection. The qualifier "loosely" is used because the state machine does not closely shadow the state of the connection and thus is capable of recovering from loss of state due to lost packets or missed communications.

The above-described structures and organization are used for all layers and all protocols within STATS. Real Time Parser (RTP)

The RTP runs as an application task. It is scheduled by the Real Time Kernel scheduler when received frames are detected. The RTP parses the frames and causes statistics, state tracking, and tracing operations to be performed.

The functions of the RTP are:

- \* obtain frames from the RTP Input Queue;
- \* parse the frames;
- \* maintain statistics using routines supplied by the STATS module;
- \* maintain protocol state information;

- \* notify the MTM via an ITM if a frame has been received with the Network Monitor's address as the destination address; and
- \* notify the EM via an ITM if a frame has been received with any Network Monitor's address as the source address.

The design of the RTP is straightforward. It is a collection of routines which perform protocol parsing. The RTP interfaces to the Real Time Kernel in order to perform RTP initialization, to be scheduled in order to parse frames, to free frames, to obtain and send an ITM to another task; and to report fatal errors. The RTP is invoked by the scheduler when there is at least one frame to parse. The appropriate parse routines are executed per frame. Each parse routine invokes the next level parse routine or decides that parsing is done. Termination of the parse occurs on an error or when the frame has been completely parsed.

Each parse routine is a separately compilable module. In general, parse routines share very little data. Each knows where to begin parsing in the frame and the length of the data remaining in the frame.

The following is a list of the parse routines that are available within RTP for parsing the different protocols at the various layers.

Data Link Layer Parse - rtp\_dll\_parse:

This routine handles Ethernet, IEEE 802.3, IEEE 802.2, and SNAP. See RFC 1010, Assigned Numbers for a description of SNAP (Subnetwork Access Protocol).

Address Resolution Protocol Parse - rtp\_arp\_parse

ARP is parsed as specified in RFC 826.

Internet Protocol Parse - rtp\_ip\_parse

IP Version 4 is parsed as specified in RFC 791 as amended by RFC 950, RFC 919, and RFC 922.

- 40 -

Internet Control Message Protocol Parse - rtp\_icmp\_parse  
 ICMP is parsed as specified in RFC 792.

Unit Data Protocol Parse - rtp\_udp\_parse  
 UDP is parsed as specified in RFC 768.

5 Transmission Control Protocol Parse - rtp\_tcp\_parse  
 TCP is parsed as specified in RFC 793.

Simple Mail Transfer Protocol Parse - rtp\_smtp\_parse  
 SMTP is parsed as specified in RFC 821.

10 File Transfer Protocol Parse - rtp\_ftp\_parse  
 FTP is parsed as specified in RFC 959.

Telnet Protocol Parse - rtp\_telnet\_parse  
 The Telnet protocol is parsed as specified in RFC  
 854.

15 Network File System Protocol Parse - rpt\_nfs\_parse  
 The NFS protocol is parsed as specified in RFC  
 1094.

The RTP calls routines supplied by STATS to look  
 up data structures. By calling these lookup routines,  
 global pointers to data structures are set up. Following  
 20 are examples of the pointers to statistics data  
 structures that are set up when parse routines call  
 Statistics module lookup routines.

mac\_segment, mac\_dst\_segment, mac\_this\_segment,  
 mac\_src, mac\_dst, mac\_dialog  
 25 ip\_src\_segment, ip\_dst\_segment, ip\_this\_segment,  
 ip\_src, ip\_dst, ip\_dialog  
 tcp\_src\_segment, tcp\_dst\_segment,  
 tcp\_this\_segment,  
 tcp\_src, tcp\_dst, tcp\_src\_socket, tcp\_dst\_socket,  
 30 tcp\_connection

The mac\_src and mac\_dst routines return pointers  
 to the data structures within STATS for the source MAC  
 address and the destination MAC address, respectively.  
 The lookup\_mac\_dialog routine returns a pointer to the  
 35 data structure within STATS for the dialog between the

two nodes on the MAC layer. The other STATS routines supply similar pointers for data structures relevant to other protocols.

The RTP routines are aware of the names of the  
5 statistics that must be manipulated within the data base (e.g. frames, bytes) but are not aware of the structure of the data. When a statistic is to be manipulated, the RTP routine invokes a macro which manipulates the  
10 appropriate statistics in data structures. The macros use the global pointers which were set up during the lookup process described above.

After a frame has been parsed (whether the parse was successful or not), the RTP routine examines the destination mac and ip addresses. If either of the  
15 addresses is that of the Network Monitor, RTP obtains a low priority ITM, initializes it, and sends the ITM to the MTM task. One of the fields of the ITM contains the address of the buffer containing the frame.

The RTP must hand some received frames to the EM  
20 in order to accomplish the autotopology function (described later). After a frame has been parsed (whether the parse was successful or not), the RTP routine examines the source mac and ip addresses. If either of the addresses is that of another Network  
25 Monitor, RTP obtains a low priority ITM, initializes it and sends the ITM to the EM task. The address data structure (in particular, the flags field of the parse control record) within STATS for the MAC or the IP address indicates whether the source address is that of  
30 another Network Monitor. One of the fields of the ITM contains the address of the buffer containing the frame.

The RTP receives traffic frames from the network for analysis. RTP operation may be modified by sending control messages to the Monitor. RTP first parses these  
35 messages, then detects that the messages are destined for

- 42 -

the Monitor and passes them to the MTM task. Parameters which affect RTP operation may be changed by such control messages.

The general operation of the RTP upon receipt of a traffic frame is as follows:

```

    Get next frame from input queue
    get address records for these stations
    For each level of active parsing
    {
10   get pointer to start of protocol header
      call layer parse routine
      determine protocol at next level
      set pointer to start of next layer protocol

      }end of frame parsing
15   if this is a monitor command add to MTM input
      queue
      if this frame is from another monitor, pass
      to EM
      check for overload -if yes tell control

```

#### 20 The State Machine:

In the described embodiment, the state machine determines and keeps state for both addresses of all TCP connections. TCP is a connection oriented transport protocol, and TCP clearly defines the connection in terms of states of the connection. There are other protocols which do not explicitly define the communication in terms of state, e.g. connectionless protocols such as NFS. Nevertheless, even in the connectionless protocols there is implicitly the concept of state because there is an expected order to the events which will occur during the course of the communication. That is, at the very least, one can identify a beginning and an end of the communication, and usually some sequence of events which will occur during the course of the communication. Thus,



even though the described embodiment involves a connection oriented protocol, the principles are applicable to many connectionless protocols or for that matter any protocol for which one can identify a beginning and an end to the communication under that protocol.

Whenever a TCP packet is detected, the RTP parses the information for that layer to identify the event associated with that packet. It then passes the identified event along with the dialog identifier to the state machine. For each address of the two parties to the communication, the state machine determines what the current state of the node is. The code within the state machine determines the state of a connection based upon a set of rules that are illustrated by the event/state table shown in Fig. 8.

The interpretation of the event/state table is as follows. The top row of the table identifies the six possible states of a TCP connection. These states are not the states defined in the TCP protocol specification. The left most column identifies the eight events which may occur during the course of a connection. Within the table is an array of boxes, each of which sits at the intersection of a particular event/state combination. Each box specifies the actions taken by the state machine if the identified event occurs while the connection is in the identified state. When the state machine receives a new event, it may perform three types of action. It may change the recorded state for the node. The state to which the node is changed is specified by the S="STATE" entry located at the top of the box. It may increment or decrement the appropriate counters to record the information relevant to that event's occurrence. (In the table, incrementing and decrementing are signified by the ++ and the -- symbols, respectively, located after the

- 44 -

identity of the variable being updated.) Or the state machine may take other actions such as those specified in the table as start close timer, Look\_for\_Data\_State, or Look\_at\_History (to be described shortly). The

5 particular actions which the state machine takes are specified in each box. An empty box indicates that no action is taken for that particular event/state combination. Note, however, that the occurrence of an event is also likely to have caused the update of

10 statistics within STATS, if not by the state machine, then by some other part of the RTP. Also note that it may be desirable to have the state machine record other events, in which case the state table would be modified to identify those other actions.

15 Two events appearing on the table deserve further explanation, namely, close timer expires and inactivity timer expires. The close timer, which is specified by TCP, is started at the end of a connection and it establishes a period during which any old packets for the

20 connection which are received are thrown away (i.e., ignored). The inactivity timer is not specified by TCP but rather is part of the Network Monitor's resource management functions. Since keeping statistics for dialogs (especially old dialogs) consumes resources, it

25 is desirable to recycle resources for a dialog if no activity has been seen for some period of time. The inactivity timer provides the mechanism for accomplishing this. It is restarted each time an event for the connection is received. If the inactivity timer expires

30 (i.e., if no event is received before the timer period ends), the connection is assumed to have gone inactive and all of the resources associated with the dialog are recycled. This involves freeing them up for use by other dialogs.

The other states and events within the table differ from but are consistent with the definitions provided by TCP and should be self evident in view of that protocol specification.

5           The event/state table can be read as follows.  
Assume, for example, that node 1 is in DATA state and the RTP receives another packet from node 1 which it determines to be a TCP FIN packet. According to the entry in the table at the intersection of FIN/DATA (i.e.,  
10 event/state), the state machine sets the state of the connection for node 1 to CLOSING, it decrements the active connections counter and it starts the close timer. When the close timer expires, assuming no other events over that connection have occurred, the state machine  
15 sets node 1's state to CLOSED and it starts the inactivity timer. If the RTP sends another SYN packet to reinitiate a new connection before the inactive timer expires, the state machine sets node 1's state to CONNECTING (see the SYN/CLOSED entry) and it increments  
20 an after close counter.

When a connection is first seen, the Network Monitor sets the state of both ends of the connection to UNKNOWN state. If some number of data and acknowledgment frames are seen from both connection ends, the states of  
25 the connection ends may be promoted to DATA state. The connection history is searched to make this determination as will be described shortly.

Referring to Figs. 9a-b, within STATS there is a history data structure 200 which the state machine uses  
30 to remember the current state of the connection, the state of each of the nodes participating in the connection and a short history of state related information. History data structure 200 is identified by a state\_pointer found at the end of the associated dialog  
35 statistics data structure in STATS (see Fig. 7c). Within

- 46 -

history data structure 200, the state machine records the current state of node 1 (field 202), the current state of node 2 (field 206) and other data relating to the corresponding node (fields 204 and 208). The other data  
5 includes, for example, the window size for the receive and transmit communications, the last detected sequence numbers for the data and acknowledgment frames, and other data transfer information.

History data structure 200 also includes a history  
10 table (field 212) for storing a short history of events which have occurred over the connection and it includes an index to the next entry within the history table for storing the information about the next received event (field 210). The history table is implemented as a  
15 circular buffer which includes sufficient memory to store, for example, 16 records. Each record, shown in Fig. 9b, stores the state of the node when the event was detected (field 218), the event which was detected (i.e., received) (field 220), the data field length (field 222),  
20 the sequence number (field 224), the acknowledgment sequence number (field 226) and the identity of the initiator of the event, i.e., either node 1 or node 2 or 0 if neither (field 228).

Though the Network Monitor operates in a  
25 promiscuous mode, it may occasionally fail to detect or it may, due to overload, lose a packet within a communication. If this occurs the state machine may not be able to accurately determine the state of the connection upon receipt of the next event. The problem  
30 is evidenced by the fact that the next event is not what was expected. When this occurs, the state machine tries to recover state by relying on state history information stored in the history table in field 212 to deduce what the state is. To deduce the current state from  
35 historical information, the state machine uses one of the

two previously mentioned routines, namely,  
Look\_for\_Data\_State and Look\_at\_History.

Referring to Fig. 10, Look\_for\_Data\_State routine  
230 searches back through the history one record at a  
5 time until it finds evidence that the current state is  
DATA state or until it reaches the end of the circular  
buffer (step 232). Routine 230 detects the existence of  
DATA state by determining whether node 1 and node 2 each  
have had at least two data events or two acknowledgment  
10 combinations with no intervening connect, disconnect or  
abort events (step 234). If such a sequence of events is  
found within the history, routine 230 enters both node 1  
and node 2 into DATA state (step 236), it increments the  
active connections counter (step 238) and then it calls a  
15 Look\_for\_Initiator routine to look for the initiator of  
the connection (step 240). If such a pattern of events  
is not found within the history, routine 230 returns  
without changing the state for the node (step 242).

As shown in Fig. 11, Look\_for\_Initiator routine  
20 240 also searches back through the history to detect a  
telltale event pattern which identifies the actual  
initiator of the connection (step 244). More  
specifically, routine 240 determines whether nodes 1 and  
2 each sent connect-related packets. If they did,  
25 routine 240 identifies the initiator as the first node to  
send a connect-related packet (step 246). If the search  
is not successful, the identity of the connection  
initiator remains unknown (step 248).

The Look\_at\_History routine is called to check  
30 back through the history to determine whether data  
transmissions have been repeated. In the case of  
retransmissions, the routine calls a  
Look\_for\_Retransmission routine 250, the operation of  
which is shown in Fig. 12. Routine 250 searches back  
35 through the history (step 252) and checks whether the

- 48 -

same initiator node has sent data twice (step 254). It detects this by comparing the current sequence number of the packet as provided by the RTP with the sequence numbers of data packets that were previously sent as reported in the history table. If a retransmission is spotted, the retransmission counter in the dialog statistics data structure of STATS is incremented (step 256). If the sequence number is not found within the history table, indicating that the received packet does not represent a retransmission, the retransmission counter is not incremented (step 258).

Other statistics such as Window probes and keep alives may also be detected by looking at the received frame, data transfer variables, and, if necessary, the history.

Even if frames are missed by the Network Monitor, because it is not directly "shadowing" the connection, the Network Monitor still keeps useful statistics about the connection. If inconsistencies are detected the Network Monitor counts them and, where appropriate, drops back to UNKNOWN state. Then, the Network Monitor waits for the connection to stabilize or deteriorate so that it can again determine the appropriate state based upon the history table.

#### 25 Principal Transactions of Network Monitor Modules:

The transactions which represent the major portion of the processing load within the Monitor, include monitoring, actions on threshold alarms, processing database get/set requests from the Management Workstation, and processing monitor control requests from the Management Workstation. Each of these mechanisms will now be briefly described.

Monitoring involves the message sequence shown in Fig. 13. In that figure, as in the other figures involving message sequences, the numbers under the

heading SEQ. identify the major steps in the sequence.

The following steps occur:

1. ISR puts Received traffic frame ITM on RTP input queue
- 5 2. request address of pertinent data structure from STATS (get parse control record for this station)
3. pass pointer to RTP
4. update statistical objects by call to statistical update routine in STATS using pointer to pertinent data structure
- 10 5. parse completed - release buffers

The major steps which follow a statistics threshold event (i.e., an alarm event) are shown in Fig.

14. The steps are as follows:

- 15 1. statistical object update causes threshold alarm
2. STATS generates threshold event ITM to event manager (EM)
3. look up appropriate action for this event
4. perform local event processing
- 20 5. generate network alarm ITM to MTM Xmit (if required)
6. format network alarm trap for Workstation from event manager data
7. send alarm to Workstation

25 The major steps in processing of a database update request (i.e., a get/set request) from the Management Workstation are shown in Fig. 15. The steps are as follows:

- 30 1. LAN ISR receives frame from network and passes it to RTP for parsing
2. RTP parses frame as for any other traffic on segment.
3. RTP detects frame is for monitor and sends received Workstation message over LAN ITM to MTM
- 35 Recv.

- 50 -

4. MTM Recv processes protocol stack.
5. MTM Recv sends database update request ITM to EM.
6. EM calls STATS to do database read or database write with appropriate IMPB
- 5 7. STATS performs database access and returns response to EM.
8. EM encodes response to Workstation and sends database update response ITM to MTM Xmit
9. MTM Xmit transmits.
- 10 The major steps in processing of a monitor control request from the Management Workstation are shown in Fig. 16. The steps are as follows:
  1. Lan ISR receives frame from network and passes received frame ITM to RTP for parsing.
  - 15 2. RTP parses frame as for any other traffic on segment.
  3. RTP detects frame is for monitor and sends received workstation message over LAN ITM to MTM Recv.
  - 20 4. MTM Recv processes protocol stack and decodes workstation command.
  5. MTM Recv sends request ITM to EM.
  6. EM calls Control with monitor control IMPB.
  7. Control performs requested operation and generates response to EM.
  - 25 8. EM sends database update response ITM to MTM Xmit.
  9. MTM Xmit encodes response to Workstation and transmits.

#### The Monitor/Workstation Interface:

- 30 The interface between the Monitor and the Management Workstation is based on the SNMP definition (RFC 1089 SNMP; RFC 1065 SMI; RFC 1066 SNMP MIB - Note: RFC means Request for Comments). All five SNMP PDU types are supported:
- 35 get-request



get-next-request  
get-response  
set-request  
trap

5 The SNMP MIB extensions are designed such that where possible a user request for data maps to a single complex MIB object. In this manner, the get-request is simple and concise to create, and the response should contain all the data necessary to build the screen. Thus, if the  
10 user requests the IP statistics for a segment this maps to an IP Segment Group.

The data in the Monitor is keyed by addresses (MAC, IP) and port numbers (telnet, FTP). The user may wish to relate his data to physical nodes entered into  
15 the network map. The mapping of addresses to physical nodes is controlled by the user (with support from the Management Workstation system where possible) and the Workstation retains this information so that when a user requests data for node 'Joe' the Workstation asks the  
20 Monitor for the data for the appropriate address(es). The node to address mapping need not be one to one.

Loading and dumping of monitors uses TFTP (Trivial File Transfer Protocol). This operates over UDP as does SNMP. The Monitor to Workstation interface follows the  
25 SNMP philosophy of operating primarily in a polled mode. The Workstation acts as the master and polls the Monitor slaves for data on a regular (configurable) basis.

The information communicated by the SNMP is represented according to that subset of ASN.1 (ISO 8824  
30 Specification of ASN.1) defined in the Internet standard Structure of Management Information (SMI - RFC 1065). The subset of the standard Management Information Base (MIB) (RFC 1066 SNMP MIB) which is supported by the Workstation is defined in Appendix III. The added value  
35 provided by the Workstation is encoded as enterprise

- 52 -

specific extensions to the MIB as defined in Appendix IV. The format for these extensions follows the SMI recommendations for object identifiers so that the Workstation extensions fall in the subtree

- 5 1.3.6.1.4.1.x.1. where x is an enterprise specific node identifier assigned by the IAB.

Appendix V is a summary of the network variables for which data is collected by the Monitor for the extended MIB and which can be retrieved by the  
10 Workstation. The summary includes short descriptions of the meaning and significance of the variables, where appropriate.

The Management Workstation:

The Management Workstation is a SUN Sparcstation  
15 (also referred to as a Sun) available from Sun Microsystems, Inc. It is running the Sun flavor of Unix and uses the Open Look Graphical User Interface (GUI) and the SunNet Manager as the base system. The options required are those to run SunNet Manager with some  
20 additional disk storage requirement.

The network is represented by a logical map illustrating the network components and the relationships between them, as shown in Fig. 17. A hierarchical network map is supported with navigation through the  
25 layers of the hierarchy, as provided by SNM. The Management Workstation determines the topology of the network and informs the user of the network objects and their connectivity so that he can create a network map. To assist with the map creation process, the Management  
30 Workstation attempts to determine the stations connected to each LAN segment to which a Monitor is attached. Automatic determination of segment topology by detecting stations is performed using the autotopology algorithms as described in copending U.S. Patent Application S.N.  
35 \*\*\*,\*\*\* entitled "Automatic Topology Monitor for Multi-

Segment Local Area Network" filed on January 14, 1991 (Attorney Docket No. 13283-NE.APP), incorporated herein by reference.

5 In normal operation, each station in the network is monitored by a single Monitor that is located on its local segment. The initial determination of the Monitor responsible for a station is based on the results of the autotopology mechanism. The user may override this initial default if required.

10 The user is informed of new stations appearing on any segment in the network via the alarm mechanism. As for other alarms, the user may select whether stations appearing on and disappearing from the network segment generate alarms and may modify the times used in the  
15 aging algorithms. When a new node alarm occurs, the user must add the new alarm to the map using the SNM tools. In this manner, the SNM system becomes aware of the nodes.

20 The sequence of events following the detection of a new node is:

1. the location of the node is determined automatically for the user.
2. the Monitor generates an alarm for the user indicating the new node and providing  
25 some or all of the following information:  
mac address of node  
ip address of node  
segment that the node is believed to be  
30 located on  
Monitor to be responsible for the node
3. the user must select the segment and add the node manually using the SNM editor

- 54 -

4. The update to the SNM database will be detected and the file reread. The Workstation database is reconstructed and the parse control records for the Monitors updated if required.

5

5. The Monitor responsible for the new node has its parse control record updated via SNMP set request(s).

An internal record of new nodes is required for the autotopology. When a new node is reported by a Network Monitor, the Management Workstation needs to have the previous location information in order to know which Network Monitors to involve in autotopology. For example, two nodes with the same IP address may exist in separate segments of the network. The history makes possible the correlation of the addresses and it makes possible duplicate address detection.

15

Before a new Monitor can communicate with the Management Workstation via SNMP it needs to be added to the SNM system files. As the SNM files are cached in the database, the file must be updated and the SNM system forced to reread it.

20

Thus, on the detection of a new Monitor the following events need to occur in order to add the Monitor to the Workstation:

25

1. The Monitor issues a trap to the Management Workstation software and requests code to be loaded from the Sun Microsystems boot/load server.
2. The code load fails as the Monitor is not known to the unix networking software at this time.
3. The Workstation confirms that the new Monitor does not exceed the configured system limits (e.g. 5 Monitors per

30

35

- Workstation) and terminates the initialization sequence if limits are exceeded. An alarm is issued to the user indicating the presence of the new Monitor and whether it can be supported.
- 5           4. The user adds the Monitor to the SNMP.HOSTS file of the SNM system, to the etc/hosts file of the Unix networking system and to the SNM map.
  - 10          5. When the files have been updated the user resets the Monitor using the set tool (described later).
  6. The Monitor again issues a trap to the Management Workstation software and  
15           requests code to be loaded from the Sun boot/load server.
  7. The code load takes place and the Monitor issues a trap requesting data from the Management Workstation.
  - 20          8. The Monitor data is issued using SNMP set requests.

Note that on receiving the set request, the SNMP proxy rereads in the (updated) SNMP.HOSTS file which now includes the new Monitor. Also note that the SNMP hosts  
25 file need only contain the Monitors, not the entire list of nodes in the system.

9. On completion of the set request(s) the Monitor run command is issued by the Workstation to bring the Monitor on line.

30           The user is responsible for entering data into the SNM database manually. During operation, the Workstation monitors the file write date for the SNM database. When this is different from the last date read, the SNM database is reread and the Workstation database  
35 reconstructed. In this manner, user updates to the SNM

- 56 -

database are incorporated into the Workstation database as quickly as possible without need for the user to take any action.

When the Workstation is loaded, the database is  
5 created from the data in the SNM file system (which the user has possibly updated). This data is checked for consistency and for conformance to the limits imposed by the Workstation at this time and a warning is generated to the user if any problems are seen. If the data errors  
10 are minor the system continues operation; if they are fatal the user is asked to correct them and Workstation operation terminates.

The monitoring functions of the Management Workstation are provided as an extension to the SNM  
15 system. They consist of additional display tools (i.e., summary tool, values tool, and set tool) which the user invokes to access the Monitor options and a Workstation event log in which all alarms are recorded.

As a result of the monitoring process, the Monitor  
20 makes a large number of statistics available to the operator. These are available for examination via the Workstation tools that are provided. In addition, the Monitor statistics (or a selected subset thereof) can be made visible to any SNMP manager by providing it with  
25 knowledge of the extended MIB. A description of the statistics maintained are described elsewhere.

Network event statistics are maintained on a per network, per segment and per node basis. Within a node, statistics are maintained on a per address (as  
30 appropriate to the protocol layer - IP address, port number, ...) and per connection basis. Per network statistics are always derived by the Workstation from the per segment variables maintained by the Monitors. Subsets of the basic statistics are maintained on a node  
35 to node and segment to segment basis.

If the user requests displays of segment to segment traffic, the Workstation calculates this data as follows. The inter segment traffic is derived from the node to node statistics for the intersecting set of 5 nodes. Thus, if segment A has nodes 1, 2, and 3 and segment B has nodes 20, 21, and 22, then summing the node to node traffic for

- 1 -> 20,21,22
- 2 -> 20,21,22
- 10 3 -> 20,21,22

produces the required result. On-LAN/off-LAN traffic for segments is calculated by a simply summing node to node traffic for all stations on the LAN and then subtracting this from total segment counts.

15 Alarms are reported to the user in the following ways:

1. Alarms received are logged in a Workstation log.
2. The node which the alarm relates to is highlighted on the map.
- 20 3. The node status change is propagated up through the (map) hierarchy to support the case where the node is not visible on the screen. This is as provided by SNMP.

#### Summary Tool

25 After the user has selected an object from the map and invokes the display tools, the summary tool generates the user's initial screen at the Management Workstation. It presents a set of statistical data selected to give an overview of the operational status of the object (e.g., a 30 selected node or segment). The Workstation polls the Monitor for the data required by the Summary Tool display screens.

The Summary Tool displays a basic summary tool screen such as is shown in Fig. 18. The summary tool 35 screen has three panels, namely, a control panel 602, a

- 58 -

values panel 604, and a dialogs panel 606. The control panel includes the indicated mouse activated buttons. The functions of each of the buttons is as follows. The file button invokes a traditional file menu. The view  
5 button invokes a view menu which allows the user to modify or tailor the visual properties of the tool. The properties button invokes a properties menu containing choices for viewing and sometimes modifying the properties of objects. The tools button invokes a tools  
10 menu which provides access to the other Workstation tools, e.g. Values Tool.

The Update Interval field allows the user to specify the frequency at which the displayed statistics are updated by polling the Monitor. The Update Once  
15 button enables the user to retrieve a single screen update. When the Update Once button is invoked not only is the screen updated but the update interval is automatically set to "none".

The type field enables the user to specify the  
20 type of network objects on which to operate, i.e., segment or node.

The name button invokes a pop up menu containing an alphabetical list of all network objects of the type selected and apply and reset buttons. The required name  
25 can then be selected from the (scrolling) list and it will be entered in the name field of the summary tool when the apply button is invoked. Alternatively, the user may enter the name directly in the summary tool name field.

30 The protocol button invokes a pop up menu which provides an exclusive set of protocol layers which the user may select. Selection of a layer copies the layer name into the displayed field of the summary tool when the apply operation is invoked. An example of a protocol  
35 selection menu is shown in Fig. 19. It displays the



available protocols in the form of a protocol tree with multiple protocol families. The protocol selection is two dimensional. That is, the user first selects the protocol family and then the particular layer within that family.

As indicated by the protocol trees shown in Fig. 19, the capabilities of the Monitor can be readily extended to handle other protocol families. The particular ones which are implemented depend upon the needs of the particular network environment in which the Monitor will operate.

The user invokes the apply button to indicate that the selection process is complete and the type, name, protocol, etc. should be applied. This then updates the screen using the new parameter set that the user selected. The reset button is used to undo the selections and restore them to their values at the last apply operation.

The set of statistics for the selected parameter set is displayed in values panel 604. The members of the sets differ depending upon, for example, what protocol was selected. Figs. 20a-g present examples of the types of statistical variables which are displayed for the DLL, IP, UDP, TCP, ICMP, NFS, and ARP/RARP protocols, respectively. The meaning of the values display fields are described in Appendix I, attached hereto.

Dialogs panel 606 contains a display of the connection statistics for all protocols for a selected node. Within the Management Workstation, connection lists are maintained per node, per supported protocol. When connections are displayed, they are sorted on "Last Seen" with the most current displayed first. A single list returned from the Monitor contains all current connection. For TCP, however, each connection also contains a state and TCP connections are displayed as

- 60 -

Past and Present based upon the returned state of the connection. For certain dialogs, such as TCP and NFS over UDP, there is an associated direction to the dialog, i.e., from the initiator (source) to the receiver (sink).  
5 For these dialogs, the direction is identified in a DIR. field. A sample of information that is displayed in dialogs panel 606 is presented in Fig. 21 for current connections.

#### Values Tool

10 The values tool provides the user with the ability to look at the statistical database for a network object in detail. When the user invokes this tool, he may select a basic data screen containing a rate values panel 620, a count values panel 622 and a protocols seen panel  
15 626, as shown in Fig. 22, or he may select a traffic matrix screen 628, as illustrated in Fig. 23.

In rate values and count values panels 620 and 622, value tools presents the monitored rate and count statistics, respectively, for a selected protocol. The  
20 parameters which are displayed for the different protocols (i.e., different groups) are listed in Appendix II. In general, a data element that is being displayed for a node shows up in three rows, namely, a total for the data element, the number into the data element, and  
25 the number out of the data element. Any exceptions to this are identified in Appendix II. Data elements that are displayed for segments, are presented as totals only, with no distinction between Rx and Tx.

When invoked the Values Tool displays a primary  
30 screen to the user. The primary screen contains what is considered to be the most significant information for the selected object. The user can view other information for the object (i.e., the statistics for the other parameters) by scrolling down.

The displayed information for the count values and rate values panels 620 and 622 includes the following. An alarm field reports whether an alarm is currently active for this item. It displays as "\*" if active alarm is present. A Current Value/Rate field reports the current rate or the value of the counter used to generate threshold alarms for this item. This is reset following each threshold trigger and thus gives an idea of how close to an alarm threshold the variable is. A Typical Value field reports what this item could be expected to read in a "normal" operating situation. This field is filled in for those items where this is predictable and useful. It is maintained in the Workstation database and is modifiable by the user using the set tool. An Accumulated Count field reports the current accumulated value of the item or the current rate. A Max Value field reports the highest value recently seen for the item. This value is reset at intervals defined by a user adjustable parameter (default 30 minutes). This is not a rolling cycle but rather represents the highest value since it was reset which may be from 1 to 30 minutes ago (for a rest period of 30 minutes). It is used only for rates. A Min Value field reports the lowest value recently seen for the item. This operates in the same manner as Max Value field and is used only for rates.

A Percent (%) field reports only for the following variables:

off seg counts:

100(in count / total off seg count)  
100(out count / total off seg count)  
100(transit count / total off seg count)  
100(local count / total off seg count)

off seg rates

100(transit rate / total off seg rate), etc.  
protocols

- 62 -

100(frame rate this protocol / total frame  
rate)

On the right half of the basic display, there the  
following additional fields: a High Threshold field and a  
5 Sample period for rates field.

#### Set Tool

The set tool provides the user with the ability to  
modify the parameters controlling the operation of the  
Monitors and the Management Workstation. These  
10 parameters affect both user interface displays and the  
actual operation of the Monitors. The parameters which  
can be operated on by the set tool can be divided into  
the following categories: alarm thresholds, monitoring  
control, segment Monitor administration, and typical  
15 values.

The monitoring control variables specify the  
actions of the segment Monitors and each Monitor can have  
a distinct set of control variables (e.g., the parse  
control records that are described elsewhere). The user  
20 is able to define those nodes, segments, dialogs and  
protocols in which he is interested so as to make the  
best use of memory space available for data storage.  
This mechanism allows for load sharing, where multiple  
Monitors on the same segment can divide up the total  
25 number of network objects which are to be monitored so  
that no duplication of effort between them takes place.

The monitor administration variables allow the  
user to modify the operation of the segment Monitor in a  
more direct manner than the monitoring control variables.  
30 Using the set tool, the user can perform those operations  
such as reset, time changes etc. which are normally the  
prerogative of a system administrator.

Note that the above descriptions of the tools  
available through the Management Workstation are not  
35 meant to imply that other choices may not be made

regarding the particular information which is displayed and the manner in which it is displayed.

Adaptively Setting Network Monitor Thresholds:

The Workstation sets the thresholds in the Network  
5 Monitor based upon the performance of the system as  
observed over an extended period of time. That is, the  
Workstation periodically samples the output of the  
Network Monitors and assembles a model of a normally  
functioning network. Then, the Workstation sets the  
10 thresholds in the Network Monitors based upon that model.  
If the observation period is chosen to be long enough and  
since the model represents the "average" of the network  
performance over the observation period, temporary  
undesired deviations from normal behavior are smoothed  
15 out over time and model tends to accurately reflect  
normal network behavior.

Referring the Fig. 24, the details of the training  
procedure for adaptively setting the Network Monitor  
thresholds are as follows. To begin training, the  
20 Workstation sends a start learning command to the Network  
Monitors from which performance data is desired (step  
302). The start learning command disables the thresholds  
within the Network Monitor and causes the Network Monitor  
to periodically send data for a predefined set of network  
25 parameters to the Management Workstation. (Disabling the  
thresholds, however, is not necessary. One could have  
the learning mode operational in parallel with monitoring  
using existing thresholds.) The set of parameters may be  
any or all of the previously mentioned parameters for  
30 which thresholds are or may be defined.

Throughout the learning period, the Network  
Monitor sends "snapshots" of the network's performance to  
the Workstation which, in turn, stores the data in a  
performance history database 306 (step 304). The network  
35 manager sets the length of the learning period.

- 64 -

Typically, it should be long enough to include the full range of load conditions that the network experiences so that a representative performance history is generated. It should also be long enough so that short periods of  
5 overload or faulty behavior do not distort the resulting averages.

After the learning period has expired, the network manager, through the Management Workstation, sends a stop learning command to the Monitor (step 308). The Monitor  
10 ceases automatically sending further performance data updates to the Workstation and the Workstation processes the data in its performance history database (step 310). The processing may involve simply computing averages for the parameters of interest or it may involve more  
15 sophisticated statistical analysis of the data, such as computing means, standard deviations, maximum and minimum values, or using curve fitting to compute rates and other pertinent parameter values.

After the Workstation has statistically analyzed  
20 the performance data, it computes a new set of thresholds for the relevant performance parameters (step 312). To do this, it uses formulas which are appropriate to the particular parameter for which a threshold is being computed. That is, if the parameter is one for which one  
25 would expect to see wide variations in its value during network monitoring, then the threshold should be set high enough so that the normal expected variations do not trigger alarms. On the other hand, if the parameter is of a type for which only small variations are expected  
30 and larger variations indicate a problem, then the threshold should be set to a value that is close to the average observed value. Examples of formulae which may be used to compute thresholds are:

- \* Highest value seen during learning period;

- \* Highest value seen during learning period + 10%;
- \* Highest value seen during learning period + 50%;
- 5 \* Highest value seen during learning period + user-defined percent;
- \* Any value of the parameter other than zero;
- \* Average value seen during learning period + 50%; and
- 10 \* Average value seen during learning period + user-defined percent.

As should be evident from these examples, there is a broad range of possibilities regarding how to compute a particular threshold. The choice, however, should  
15 reflect the parameter's importance in signaling serious network problems and its normal expected behavior (as may be evidenced from the performance history acquired for the parameter during the learning mode).

After the thresholds are computed, the Workstation  
20 loads them into the Monitor and instructs the Monitor to revert to normal monitoring using the new thresholds (step 314).

This procedure provides a mechanism enabling the network manager to adaptively reset thresholds in  
25 response to changing conditions on the network, shifting usage patterns and evolving network topology. As the network changes over time, the network manager merely invokes the adaptive threshold setting feature and updates the thresholds to reflect those changes.

30 The Diagnostic Analyzer Module:

The Management Workstation includes a diagnostic analyzer module which automatically detects and diagnoses the existence and cause of certain types of network problems. The functions of the diagnostic module may  
35 actually be distributed among the Workstation and the

- 66 -

Network Monitors which are active on the network. In principle, the diagnostic analyzer module includes the following elements for performing its fault detection and analysis functions.

5           The Management Workstation contains a reference model of a normally operating network. The reference model is generated by observing the performance of the network over an extended period of time and computing averages of the performance statistics that were observed  
10 during the observation period. The reference model provides a reference against which future network performance can be compared so as to diagnose and analyze potential problems. The Network Monitor (in particular, the STATS module) includes alarm thresholds on a selected  
15 set of the parameters which it monitors. Some of those thresholds are set on parameters which tend to be indicative of the onset or the presence of particular network problems.

          During monitoring, when a Monitor threshold is  
20 exceeded, thereby indicating a potential problem (e.g. in a TCP connection), the Network Monitor alerts the Workstation by sending an alarm. The Workstation notifies the user and presents the user with the option of either ignoring the alarm or invoking a diagnostic  
25 algorithm to analyze the problem. If the user invokes the diagnostic algorithm, the Workstation compares the current performance statistics to its reference model to analyze the problem and report its results. (Of course, this may also be handled automatically so as to not  
30 require user intervention.) The Workstation obtains the data on current performance of the network by retrieving the relevant performance statistics from all of the segment Network Monitors that may have information useful to diagnosing the problem.



The details of a specific example involving poor TCP connection performance will now be described. This example refers to a typical network on which the diagnostic analyzer resides, such as the network  
5 illustrated in Fig. 25. It includes three segments labelled S1, S2, and S3, a router R1 connecting S1 to S2, a router R2 connecting S2 to S3, and at least two nodes, node A on S1 which communicates with node B on S3. On each segment there is also a Network Monitor 324 to  
10 observe the performance of its segment in the manner described earlier. A Management Workstation 320 is also located on S1 and it includes a diagnostic analyzer module 322. For this example, the symptom of the network problem is degraded performance of a TCP connection  
15 between Nodes A and B.

A TCP connection problem may manifest itself in a number of ways, including, for example, excessively high numbers for any of the following:

- errors
- 20 packets with bad sequence numbers
- packets retransmitted
- bytes retransmitted
- out of order packets
- out of order bytes
- 25 packets after window closed
- bytes after window closed
- average and maximum round trip times

or by an unusually low value for the current window size. By setting the appropriate thresholds, the Monitor is  
30 programmed to recognize any one or more of these symptoms. If any one of of the thresholds is exceeded, the Monitor sends an alarm to the Workstation. The Workstation is programmed to recognize the particular alarm as related to an event which can be further  
35 analyzed by its diagnostic analyzer module 322. Thus,

- 68 -

the Workstation presents the user with the option of invoking its diagnostic capabilities (or automatically invokes the diagnostic capabilities).

In general terms, when the diagnostic analyzer is  
5 invoked, it looks at the performance data that the segment Monitors produce for the two nodes, for the dialogs between them and for the links that interconnect them and compares that data to the reference model for the network. If a significant divergence from the  
10 reference model is identified, the diagnostic analyzer informs the Workstation (and the user) about the nature of the divergence and the likely cause of the problem. In conducting the comparison to "normal" network performance, the network circuit involved in  
15 communications between nodes A and B is decomposed into its individual components and diagnostic analysis is performed on each link individually in the effort to isolate the problem further.

The overall structure of the diagnostic algorithm  
20 400 is shown in Fig. 26. When invoked for analyzing a possible TCP problem between nodes A and B, diagnostic analyzer 322 checks for a TCP problem at node A when it is acting as a source node (step 402). To perform this check, diagnostic algorithm 400 invokes a source node  
25 analyzer algorithm 450 shown in Fig. 27. If a problem is identified, the Workstation reports that there is a high probability that node A is causing a TCP problem when operating as a source node and it reports the results of the investigation performed by algorithm 450 (step 404).

30 If node A does not appear to be experiencing a TCP problem when acting as a source node, diagnostic analyzer 322 checks for evidence of a TCP problem at node B when it is acting as a sink node (step 406). To perform this check, diagnostic algorithm 400 invokes a sink node  
35 analyzer algorithm 470 shown in Fig. 28. If a problem is

identified, the Workstation reports that there is a high probability that node B is causing a TCP problem when operating as a sink node and it reports the results of the investigation performed by algorithm 470 (step 408).

5           Note that source and sink nodes are concepts which apply to those dialogs for which a direction of the communication can be defined. For example, the source node may be the one which initiated the dialog for the purpose of sending data to the other node, i.e., the sink  
10 node.

          If node B does not appear to be experiencing a TCP problem when acting as a sink node, diagnostic analyzer 322 checks for evidence of a TCP problem on the link between Node A and Node B (step 410). To perform this  
15 check, diagnostic algorithm 400 invokes a link analysis algorithm 550 shown in Fig. 29. If a problem is identified, the Workstation reports that there is a high probability that a TCP problem exists on the link and it reports the results of the investigation performed by  
20 link analysis algorithm 550 (step 412).

          If the link does not appear to be experiencing a TCP problem, diagnostic analyzer 322 checks for evidence of a TCP problem at node B when it is acting as a source node (step 414). To perform this check, diagnostic  
25 algorithm 400 invokes the previously mentioned source algorithm 450 for Node B. If a problem is identified, the Workstation reports that there is a medium probability that node B is causing a TCP problem when operating as a source node and it reports the results of  
30 the investigation performed by algorithm 450 (step 416).

          If node B does not appear to be experiencing a TCP problem when acting as a source node, diagnostic analyzer 322 checks for a TCP problem at node A when it is acting as a sink node (step 418). To perform this check,  
35 diagnostic algorithm 400 invokes sink node analyzer

- 70 -

algorithm 470 for Node A. If a problem is identified, the Network Monitor reports that there is a medium probability that node A is causing a TCP problem when operating as a sink node and it reports the results of the investigation performed by algorithm 470 (step 420).

Finally, if node A does not appear to be experiencing a TCP problem when acting as a sink node, diagnostic analyzer 322 reports that it was not able to isolate the cause of a TCP problem (step 422).

10 The algorithms which are called from within the above-described diagnostic algorithm will now be described. Referring to Fig. 27, source node analyzer algorithm 450 checks whether a particular node is causing a TCP problem when operating as a source node. The  
15 strategy is as follows. To determine whether a TCP problem exists at this node which is the source node for the TCP connection, look at other connections for which this node is a source. If other TCP connections are okay, then there is probably not a problem with this  
20 node. This is an easy check with a high probability of being correct. If no other good connections exist, then look at the lower layers for possible reasons. Start at DLL and work up as problems at lower layers are more fundamental, i.e., they cause problems at higher layers  
25 whereas the reverse is not true.

In accordance with this approach, algorithm 450 first determines whether the node is acting as a source node in any other TCP connection and, if so, whether the other connection is okay (step 452). If the node is  
30 performing satisfactorily as a source node in another TCP connection, algorithm 450 reports that there is no problem at the source node and returns to diagnostic algorithm 400 (step 454). If algorithm 450 cannot identify any other TCP connections involving this node  
35 that are okay, it moves up through the protocol stack

checking each level for a problem. In this case, it then checks for DLL problems at the node when it is acting as a source node by calling an DLL problem checking routine 510 (see Fig. 30) (step 456). If a DLL problem is found, 5 that fact is reported (step 458). If no DLL problems are found, algorithm 450 checks for an IP problem at the node when it is acting as a source by calling an IP problem checking routine 490 (see Fig. 31) (step 460). If an IP problem is found, that fact is reported (step 462). If 10 no IP problems are found, algorithm 450 checks whether any other TCP connection in which the node participates as a source is not okay (step 464). If another TCP connection involving the node exists and it is not okay, algorithm 450 reports a TCP problem at the node (step 15 466). If no other TCP connections where the node is acting as a source node can be found, algorithm 450 exits.

Referring to Fig. 28, sink node analyzer algorithm 470 checks whether a particular node is causing a TCP 20 problem when operating as a sink node. It first determines whether the node is acting as a sink node in any other TCP connection and, if so, whether the other connection is okay (step 472). If the node is performing satisfactorily as a sink node in another TCP connection, 25 algorithm 470 reports that there is no problem at the source node and returns to diagnostic algorithm 400 (step 474). If algorithm 470 cannot identify any other TCP connections involving this node that are okay, it then checks for DLL problems at the node when it is acting as 30 a sink node by calling DLL problem checking routine 510 (step 476). If a DLL problem is found, that fact is reported (step 478). If no DLL problems are found, algorithm 470 checks for an IP problem at the node when it is acting as a sink by calling IP problem checking 35 routine 490 (step 480). If an IP problem is found, that

- 72 -

fact is reported (step 482). If no IP problems are found, algorithm 470 checks whether any other TCP connection in which the node participates as a sink is not okay (step 484). If another TCP connection involving  
5 the node as a sink exists and it is not okay, algorithm 470 reports a TCP problem at the node (step 486). If no other TCP connections where the node is acting as a sink node can be found, algorithm 470 exits.

Referring to Fig. 31, IP problem checking routine  
10 490 checks for IP problems at a node. It does this by comparing the IP performance statistics for the node to the reference model (steps 492 and 494). If it detects any significant deviations from the reference model, it reports that there is an IP problem at the node (step  
15 496). If no significant deviations are noted, it reports that there is no IP problem at the node (step 498).

As revealed by examining Fig. 30, DLL problem checking routine 510 operates in a similar manner to IP problem checking routine 490, with the exception that it  
20 examines a different set of parameters (i.e., DLL parameters) for significant deviations.

Referring the Fig. 29, link analysis logic 550 first determines whether any other TCP connection for the link is operating properly (step 552). If a properly  
25 operating TCP connection exists on the link, indicating that there is no link problem, link analysis logic 550 reports that the link is okay (step 554). If a properly operating TCP connection cannot be found, the link is decomposed into its constituent components and an IP link  
30 component problem checking routine 570 (see Fig. 32) is invoked for each of the link components (step 556). IP link component problem routine 570 evaluates the link component by checking the IP layer statistics for the relevant link component.

The decomposition of the link into its components arranges them in order of their distance from the source node and the analysis of the components proceeds in that order. Thus, for example, the link components which make up the link between nodes A and B include in order: segment S1, router R1, segment S2, router R2, and segment S3. The IP data for these various components are analyzed in the following order:

10 IP data for segment S1  
IP data for address R1  
IP data for source node to R1  
IP data for S1 to S2  
IP data for S2  
IP data for address R2  
15 IP data for S3  
IP data for S2 to S3  
IP data for S1 to S3

As shown in Fig. 32, IP link component problem checking routine 570 compares IP statistics for the link component to the reference model (step 572) to determine whether network performance deviates significantly from that specified by the model (step 574). If significant deviations are detected, routine 570 reports that there is an IP problem at the link component (step 576).  
25 Otherwise, it reports that it found no IP problem (step 578).

Referring back to Fig. 29, after completing the IP problem analysis for all of the link components, logic 550 then invokes a DLL link component problem checking routine 580 (see Fig. 33) for each link component to check its DLL statistics (step 558).  
30

DLL link problem routine 580 is similar to IP link problem routine 570. As shown in Fig. 33, DLL link problem checking routine 580 compares DLL statistics for the link to the reference model (step 582) to determine  
35

- 74 -

whether network performance at the DLL deviates significantly from that specified by the model (step 584). If significant deviations are detected, routine 580 reports that there is a DLL problem at the link component (step 586). Otherwise, it reports that no DLL problems were found (step 588).

Referring back to Fig. 29, after completing the DLL problem analysis for all of the link components, logic 550 checks whether there is any other TCP on the link (step 560). If another TCP exists on the link (which implies that the other TCP is also not operating properly), logic 550 reports that there is a TCP problem on the link (step 562). Otherwise, logic 550 reports that there was not enough information from the existing packet traffic to determine whether there was a link problem (step 564)

If the analysis of the link components does not isolate the source of the problem and if there were components for which sufficient information was not available (due possibly to lack of traffic over through that component), the user may send test messages to those components to generate the information needed to evaluate its performance.

The reference model against which comparisons are made to detect and isolate malfunctions may be generated by examining the behavior of the network over an extended period of operation or over multiple periods of operation. During those periods of operation, average values and maximum excursions (or standard deviations) for observed statistics are computed. These values provide an initial estimate of a model of a properly functioning system. As more experience with the network is obtained and as more historical data on the various statistics is accumulated the thresholds for detecting actual malfunctions or imminent malfunctions and the



reference model can be revised to reflect the new experience.

What constitutes a significant deviation from the reference model depends upon the particular parameter  
5 involved. Some parameters will not deviate from the expected norm and thus any deviation would be considered to be significant, for example, consider ICMP messages of type "destination unreachable," IP errors, TCP errors. Other parameters will normally vary within a wide range  
10 of acceptable values, and only if they move outside of that range should the deviation be considered significant. The acceptable ranges of variation can be determined by watching network performance over a sustained period of operation.

15 The parameters which tend to provide useful information for identifying and isolating problems at the node level for the different protocols and layers include the following.

20 TCP  
error rate  
header byte rate  
packets retransmitted  
bytes retransmitted  
packets after window closed  
25 bytes after window closed

UDP  
error rate  
header byte rate

30 IP  
error rate  
header byte rate  
fragmentation rate  
all ICMP messages of type destination

- 76 -

unreachable, parameter problem,  
redirection

DLL  
error rate  
5 runts

For diagnosing network segment problems, the above-identified parameters are also useful with the addition of the alignment rate and the collision rate at the DLL. All or some subset of these parameters may be included  
10 among the set of parameters which are examined during the diagnostic procedure to detect and isolate network problems.

The above-described technique can be applied to a wide range of problems on the network, including among  
15 others, the following:

TCP Connection fails to establish  
UDP Connection performs poorly  
UDP not working at all  
IP poor performance/high error rate  
20 IP not working at all  
DLL poor performance/high error rate  
DLL not working at all

For each of these problems, the diagnostic approach would be similar to that described above, using, of course,  
25 different parameters to identify the potential problem and isolate its cause.

#### The Event Timing Module

Referring again to Fig. 5, the RTP is programmed to detect the occurrence of certain transactions for  
30 which timing information is desired. The transactions typically occur within a dialog at a particular layer of the protocol stack and they involve a first event (i.e., an initiating event) and a subsequent partner event or response. The events are protocol messages that arrive

at the Network Monitor, are parsed by the RTP and then passed to Event Timing Module (ETM) for processing. A transaction of interest might be, for example, a read of a file on a server. In that case, the initiating event  
5 is the read request and the partner event is the read response. The time of interest is the time required to receive a response to the read request (i.e., the transaction time). The transaction time provides a useful measure of network performance and if measured at  
10 various times throughout the day under different load conditions gives a measure of how different loads affect network response times. The layer of the communication protocol at which the relevant dialog takes place will of course depend upon the nature of the event.

15 In general, when the RTP detects an event, it transfers control to the ETM which records an arrival time for the event. If the event is an initiating event, the ETM stores the arrival time in an event timing database 300 (see Fig. 34) for future use. If the event  
20 is a partner event, the ETM computes a difference between that arrival time and an earlier stored time for the initiating event to determine the complete transaction time.

Event timing database 300 is an array of records  
25 302. Each record 302 includes a dialog field 304 for identifying the dialog over which the transactions of interest are occurring and it includes an entry type field 306 for identifying the event type of interest. Each record 302 also includes a start time field 308 for  
30 storing the arrival time of the initiating event and an average delay time field 310 for storing the computed average delay for the transactions. A more detailed description of the operation of the ETM follows.

Referring to Fig. 35, when the RTP detects the  
35 arrival of a packet of the type for which timing

- 78 -

information is being kept, it passes control to the ETM along with relevant information from the packet, such as the dialog identifier and the event type (step 320). The ETM then determines whether it is to keep timing  
5 information for that particular event by checking the event timing database (step 322). Since each event type can have multiple occurrences (i.e., there can be multiple dialogs at a given layer), the dialog identifier is used to distinguish between events of the same type  
10 for different dialogs and to identify those for which information has been requested. All of the dialog/events of interest are identified in the event timing database. If the current dialog and event appear in the event timing database, indicating that the event should be  
15 timed, the ETM determines whether the event is a starting event or an ending event so that it may be processed properly (step 324). For certain events, the absence of a start time in the entry field of the appropriate record  
302 in event timing database 300 is one indicator that  
20 the event represents a start time; otherwise, it is an end time event. For other events, the ETM determines if the start time is to be set by the event type as specified in the packet being parsed. For example, if the event is a file read a start time is stored. If the  
25 event is the read completion it represents an end time. In general, each protocol event will have its own intrinsic meaning for how to determine start and end times.

Note that the arrival time is only an estimate of  
30 the actual arrival time due to possible queuing and other processing delays. Nevertheless, the delays are generally so small in comparison to the transaction times being measured that they are of little consequence.

In step 324, if the event represents a start time,  
35 the ETM gets the current time from the kernal and stores

it in start time field 308 of the appropriate record in event timing database 300 (step 326). If the event represents an end time event, the ETM obtains the current time from the kernel and computes a difference between  
5 that time and the corresponding start time found in event timing database 300 (step 328). This represents the total time for the transaction of interest. It is combined with the stored average transaction time to compute a new running average transaction time for that  
10 event (step 330).

Any one of many different methods can be used to compute the running average transaction time. For example, the following formula can be used:

New Avg. = [(5 \* Stored Avg.) + Transaction  
15 Time]/6.

After six transaction have been timed, the computed new average becomes a running average for the transaction times. The ETM stores this computed average in the appropriate record of event timing database 300,  
20 replacing the previous average transaction time stored in that record, and it clears start time entry field 308 for that record in preparation for timing the next transaction.

After processing the event in steps 322, 326, and  
25 330, the ETM checks the age of all of the start time entries in the event timing database 300 to determine if any of them are too "old" (step 332). If the difference between the current time and any of the start times exceeds a preselected threshold, indicating that a  
30 partner event has not occurred within a reasonable period of time, the ETM deletes the old start time entry for that dialog/event (step 334). This insures that a missed packet for a partner event does not result in an erroneously large transaction time which throws off the  
35 running average for that event.

- 80 -

If the average transaction time increases beyond a preselected threshold set for timing events, an alarm is sent to the Workstation.

Two examples will now be described to illustrate the operation of the ETM for specific event types. In the first example, Node A of Fig. 25 is communicating with Node B using the NFS protocol. Node A is the client while Node B is the server. The Network Monitor resides on the same segment as node A, but this is not a requirement. When Node A issues a read request to Node B, the Network Monitor sees the request and the RTP within the Network Monitor transfers control to the ETM. Since it is a read, the ETM stores a start time in the Event Timing Database. Thus, the start time is the time at which the read was initiated.

After some delay, caused by the transmission delays of getting the read message to node B, node B performs the read and sends a response back to node A. After some further transmission delays in returning the read response, the Network Monitor receives the second packet for the event. At the time, the ETM recognizes that the event is an end time event and updates the average transaction time entry in the appropriate record with a new computed running average. The ETM then compares the average transaction time with the threshold for this event and if it has been exceeded, issues an alarm to the Workstation.

In the second example, node A is communicating with Node B using the Telnet protocol. Telnet is a virtual terminal protocol. The events of interest take place long after the initial connection has been established. Node A is typing at a standard ASCII (VT100 class) terminal which is logically (through the network) connected to Node B. Node B has an application which is receiving the characters being typed on Node A and, at

appropriate times, indicated by the logic of the applications, sends characters back to the terminal located on Node A. Thus, every time node A sends characters to B, the Network Monitor sees the  
5 transmission.

In this case, there are several transaction times which could provide useful network performance information. They include, for example, the amount of time it takes to echo characters typed at the keyboard  
10 through the network and back to the display screen, the delay between typing an end of line command and seeing the completion of the application event come back or the network delays incurred in sending a packet and receiving acknowledgment for when it was received.

In this example, the particular time being measured is the time it takes for the network to send a packet and receive an acknowledgement that the packet has arrived. Since Telnet runs on top of TCP, which in turn runs on top of IP, the Network Monitor monitors the TCP  
15 acknowledge end-to-end time delays.  
20

Note that this is a design choice of the implementation and that all events visible to the Network Monitor by virtue of the fact that information is in the packet could be measured.

When Node A transmits a data packet to Node B, the Network Monitor receives the packet. The RTP recognizes the packet as being part of a timed transaction and passes control to the ETM. The ETM recognizes it as a start time event, stores the start time in the event  
25 timing database and returns control to the RTP after  
30 checking for aging.

When Node B receives the data packet from Node A, it sends back an acknowledgment packet. When the Network Monitor sees that packet, it delivers the event to the  
35 ETM, which recognizes it as an end time event. The ETM

- 82 -

calculates the delay time for the complete transaction and uses that to update the average transaction time. The ETM then compares the new average transaction time with the threshold for this event. If it has been  
5 exceeded, the ETM issues an alarm to the Workstation.

Note that this example is measuring something very different than the previous example. The first example measures the time it takes to traverse the network, perform an action and return that result to the  
10 requesting node. It measures performance as seen by the user and it includes delay times from the network as well as delay times from the File Server.

The second example is measuring network delays without looking at the service delays. That is, the ETM  
15 is measuring the amount of time it takes to send a packet to a node and receive the acknowledgement of the receipt of the message. In this example, the ETM is measuring transmissions delays as well as processing delays associated with network traffic, but not anything having  
20 to do with non-network processing.

As can be seen from the above examples, the ETM can measure a broad range of events. Each of these events can be measured passively and without the cooperation of the nodes that are actually participating  
25 in the transmission.

#### The Address Tracker Module (ATM)

Address tracker module (ATM) 43, one of the software modules in the Network Monitor (see Fig. 5), operates on networks on which the node addresses for  
30 particular node to node connections are assigned dynamically. An Appletalk® Network, developed by Apple Computer Company, is an example of a network which uses dynamic node addressing. In such networks, the dynamic change in the address of a particular service causes  
35 difficulty troubleshooting the network because the



network manager may not know where the various nodes are and what they are called. In addition, foreign network addresses (e.g., the IP addresses used by that node for communication over an IP network to which it is  
5 connected) can not be relied upon to point to a particular node. ATM 43 solves this problem by passively monitoring the network traffic and collecting a table showing the node address to node name mappings.

In the following description, the network on which  
10 the Monitor is located is assumed to be an Appletalk® Network. Thus, as background for the following discussion, the manner in which the dynamic node addressing mechanism operates on that network will first be described.

15 When a node is activated on the Appletalk® Network, it establishes its own node address in accordance with protocol referred to as the Local Link Access Protocol (LLAP). That is, the node guesses its own node address and then verifies that no other node on  
20 the network is using that address. The node verifies the uniqueness of its guess by sending an LLAP Enquiry control packet informing all other nodes on the network that it is going to assign itself a particular address unless another node responds that the address has already  
25 been assigned. If no other node claims that address as its own by sending an LLAP acknowledgment control packet, the first node uses the address which it has selected. If another node claims the address as its own, the first node tries another address. This continues until, the  
30 node finds an unused address.

When the first node wants to communicate with a second node, it must determine the dynamically assigned node address of the second node. It does this in accordance with another protocol referred to as the Name  
35 Binding Protocol (NBP). The Name Binding Protocol is

- 84 -

used to map or bind human understandable node names with machine understandable node addresses. The NBP allows nodes to dynamically translate a string of characters (i.e., a node name) into a node address. The node  
5 needing to communicate with another node broadcasts an NBP Lookup packet containing the name for which a node address is being requested. The node having the name being requested responds with its address and returns a  
10 Lookup Reply packet containing its address to the original requesting node. The first node then uses that address its current communications with the second node.

Referring to Fig. 36, the network includes an Appletalk® Network segment 702 and a TCP/IP segment 704, each of which are connected to a larger network 706  
15 through their respective gateways 708. A Monitor 710, including a Real Time Parser (RTP) 712 and an Address Tracking Module (ATM) 714, is located on Appletalk network segment 702 along with other nodes 711. A  
20 Management Workstation 716 is located on segment 704. It is assumed that Monitor 710 has the features and capabilities previously described; therefore, those features not specifically related to the dynamic node  
25 addressing capability will not be repeated here but rather the reader is referred to the earlier discussion. Suffice it to say that Monitor 710 is, of course, adapted to operate on Appletalk Network segment 702, to parse and  
30 analyze the packets which are transmitted over that segment according to the Appletalk® family of protocols and to communicate the information which it extracts from the network to Management Workstation 716 located on  
segment 704.

Within Monitor 710, ATM 714 maintains a name table data structure 730 such as is shown in Fig. 37. Name  
35 Table 720 includes records 722, each of which has a node name field 724, a node address field 726, an IP address

field 728, and a time field 729. ATM 714 uses Name Table 720 to keep track of the mappings of node names to node address and to IP address. The relevance of each of the fields of records 722 in Name Table 720 are explained in 5 the following description of how ATM 714 operates.

In general, Monitor 710 operates as previously described. That is, it passively monitors all packet traffic over segment 702 and sends all packets to RTP 712 for parsing. When RTP 712 recognizes an Appletalk 10 packet, it transfers control to ATM 714 which analyzes the packet for the presence of address mapping information.

The operation of ATM 714 is shown in greater detail in the flow diagram of Fig. 38. When ATM 714 15 receives control from RTP 712, it takes the packet (step 730 and strips off the lower layers of the protocol until it determines whether there is a Name Binding Protocol message inside the packet (step 732). If it is a NBP message, ATM 714 then determines whether it is new name 20 Lookup message (step 734). If it is a new name Lookup message, ATM 714 extracts the name from the message (i.e., the name for which a node address is being requested) and adds the name to the node name field 724 of a record 722 in Name Table 720 (step 736).

25 If the message is an NBP message but it is not a Lookup message, ATM 714 determines whether it is a Lookup Reply (step 738). If it is a Lookup Reply, signifying that it contains a node name/node address binding, ATM 714 extracts the name and the assigned node address from 30 the message and adds this information to Name Table 720. ATM 714 does this by searching the name fields of records 722 in Name Table 720 until it locates the name. Then, it updates the node address field of the identified record to contain the node address which was extracted 35 from the received NBP packet. ATM 714 also updates time

- 86 -

field 729 to record the time at which the message was processed.

After ATM 714 has updated the address field of the appropriate record, it determines whether any records 722  
5 in Name Table 720 should be aged out (step 742). ATM 714 compares the current time to the times recorded in the time fields. If the elapsed time is greater than a preselected time period (e.g. 48 hours), ATM 714 clears the record of all information (step 744). After that, it  
10 awaits the next packet from RTP 712.

As ATM 714 is processing each a packet and it determines either that it does not contain an NBP message (step 732) or it does not contain a Lookup Reply message (step 738), ATM 714 branches to step 742 to perform the  
15 age out check before going on to the next packet from RTP 712.

The Appletalk to IP gateways provide services that allow an Appletalk Node to dynamically connect to an IP address for communicating with IP nodes. This service  
20 extends the dynamic node address mechanism to the IP world for all Appletalk nodes. While the flexibility provided is helpful to the users, the network manager is faced with the problem of not knowing which Appletalk Nodes are currently using a particular IP address and  
25 thus, they can not easily track down problems created by the particular node.

ATM 714 can use passive monitoring of the IP address assignment mechanisms to provide the network manager a Name-to-IP address mapping.

30 If ATM 714 is also keeping IP address information, it implements the additional steps shown in Fig. 39 after completing the node name to node address mapping steps. ATM 714 again checks whether it is an NBP message (step 748). If it is an NBP message, ATM 714 checks whether it  
35 is a response to an IP address request (step 750). IP

address requests are typically implied by an NBP Lookup request for an IP gateway. The gateway responds by supplying the gateway address as well as an IP address that is assigned to the requesting node. If the NBP  
5 message is an IP address response, ATM 714 looks up the requesting node in Name Table 720 (step 752) and stores the IP address assignment in the IP address field of the appropriate record 722 (step 754).

After storing the IP address assignment  
10 information, ATM 714 locates all other records 722 in Name Table 720 which contain that IP address. Since the IP address has been assigned to a new node name, those old entries are no longer valid and must be eliminated. Therefore, ATM 714 purges the IP address fields of those  
15 records (step 756). After doing this cleanup step, ATM 714 returns control to RTP 712.

Other embodiments are within the following claims. For example, the Network Monitor can be adapted to identify node types by analyzing the type of packet  
20 traffic to or from the node. If the node being monitored is receiving mount requests, the Monitor would report that the node is behaving like node a file server. If the node is issuing routing requests, the Monitor would report that the node is behaving like a router. In  
25 either case, the network manager can check a table of what nodes are permitted to provide what functions to determine whether the node is authorized to function as either a file server or a router, and if not, can take appropriate action to correct the problem.

- 88 -

## APPENDIX I

## SNMP MIB Subset Supported

This is the subset of the standard MIB which can be obtained by monitoring.

Refer to RFC 1066 Management Information Base for an explanation on the items which follow.

System group:  
none

Interfaces group  
ifType  
ifPhysAddress  
ifOperStatus  
ifInOctets  
ifInUcastPkts  
ifInNUcastPkts  
ifOutOctets  
ifOutUcastPkts  
ifOutNUcastPkts

Address Translation group  
none

IP group  
ipForwarding  
ipDefaultTTL  
ipInReceives  
ipInHdrErrors  
ipInAddrErrors  
ipForwDatagrams  
ipReasmReqds  
ipFragCreates

IP Address Table  
ipAddress  
ipAdEntBcastAddr

IP Routing Table  
none

ICMP group  
icmpInMsgs  
icmpInErrors  
icmpInDestUnreachs  
icmpInTimeExcds  
icmpInParmProbs  
icmpInSrcQuenchs  
icmpInRedirects  
icmpInEchoes

App. I - 1



**UNITED STATES DEPARTMENT OF COMMERCE**  
**Patent and Trademark Office**  
 Address: COMMISSIONER OF PATENTS AND TRADEMARKS  
 Washington, D.C. 20231

APPLICATION NO. 08/533,115	FILING DATE 09/25/95	FIRST NAMED INVENTOR HUTTON	ATTORNEY DOCKET NO.
-------------------------------	-------------------------	--------------------------------	---------------------

BOOSTEIN & KUDIRKA, PC  
 ONE BEACON STREET  
 BOSTON MA 02108

E3M1/0818

KAMINER GREGORY R.
-----------------------

ART UNIT	PAPER NUMBER
----------	--------------

08/18/97

DATE MAILED

Please find below and/or attached an Office communication concerning this application or proceeding.

Commissioner of Patents and Trademarks

*See attached.*

**KUDIRKA & JOBSE, LLP**  
One Beacon Street  
Boston, MA 02108  
Tel (617) 367-4600  
Fax (617) 367-4656

**FACSIMILE COVER SHEET**

Number of pages being transmitted (including cover sheet): 2

Date: 9/10/97

Recipient's Name Ex. Ken Weider

Company Name USPTO

Facsimile Number (703) 305-3991

Telephone Number (703) 305-4710

From Facsimile Number (617) 367-4656

Sender's Name Bruce Jobse

**Original Documents Via**

First Class Mail  Overnight  E-Mail  Not Sent

**Comments or Instructions**

This transmission contains confidential information intended for use only by the above-named recipient. Reading, discussion, distribution, or copying of this message is strictly prohibited by anyone other than the named recipient, or his or her employees or agents. If you have received this fax in error, please immediately notify us by telephone (collect), and return the original message to us at the above address via the U.S. Postal Service.

**IF YOU DID NOT RECEIVE ALL OF THE PAGES OF THIS TRANSMISSION  
OR IF ANY OF THE PAGES ARE ILLEGIBLE, PLEASE CALL  
IMMEDIATELY AT (617) 367-4600**

Our File Number(s) N0003/7000  
Your File Number(s) \_\_\_\_\_





UNITED STATES DEPARTMENT OF COMMERCE  
Patent and Trademark Office  
ASSISTANT SECRETARY AND COMMISSIONER OF  
PATENTS AND TRADEMARKS  
Washington, D.C. 20231

FAX RECEIVED  
SEP 10 1997  
GROUP 2600

Bookstein & Kudirka, PC  
One Beacon Street  
Boston, Mass. 02108

Applicant: Glenn W. Hutton : Decision on Petition Under  
Filed: September 25, 1995 : 37 CFR Section 1.48 (c)  
Serial No. 08/533,115 :  
For: Point to Point Internet Protocol :

This is a decision on the petition filed on April 21, 1997 to add originally named inventors under 37 CFR Section 1.48(c). Applicants request that Shane D. Mattaway and Craig B. Strickland be added to the above referenced application as they contributed to the invention subject matter added by preliminary amendment which was filed on April 10, 1996, after the original filing of the application.

The petition includes a verified statement of facts but does not include a statement that the error was made without deceptive intention, as required by 37 CFR Section 1.48(a). Also the consent by the assignee is not acceptable at this time because it is not accompanied by a proper certification under 37 CFR Section 3.73(b). The consent must also include a statement specifying that the evidentiary document (assignment paper) has been reviewed and that to the best of the assignee's knowledge and belief, title is in the assignee seeking to take action. The consent must also be verified in the form of a declaration.

Therefore, the petition is DENIED. The petition may be resubmitted in proper form for reconsideration.

Alyssa H. Bowler  
Supervisory Patent Examiner  
Art Unit 2302

(Copy of paper #12)



ATTORNEY DOCKET NO. N0003/7000

#14  
Pat. to  
Correct  
Invent.  
12/19/97  
CLASS 2500  
F50-9 57  
F50-9 57

IN THE UNITED STATES PATENT AND TRADEMARK OFFICE

Applicant: Glenn W. Hutton  
Serial No.: 08/533,115  
Filed: September 25, 1995  
For: POINT-TO-POINT INTERNET PROTOCOL  
Examiner: Richard J. Gregson, Esq.  
Art Unit: 2302

CERTIFICATE OF MAILING UNDER 37 C.F.R. §1.8(a)

The undersigned hereby certifies that this document is being placed in the United States mail with first-class postage attached, addressed to Assistant Commissioner for Patents, Washington, DC 20231 on the 2nd day of December, 1997.

Anna Maria Keel  
Anna Maria Keel

Assistant Commissioner for Patents  
Washington, D.C. 20231

**PETITION TO ADD TO ORIGINALLY NAMED INVENTOR(S) UNDER 37 CFR 1.48(c)**

Sir/Madam:

Applicant respectfully requests that the above-identified application be amended under 37 CFR 1.48(c) to add inventors for subject matter disclosed in the application but previously unclaimed. This Petition to Add to Originally Named Inventor is being resubmitted following denial of the originally submitted Petition as set forth in paper number 12. The Applicant's attorney has since discussed the subject matter and form of the Petition with Special Petitions Examiner Ken Weider of the USPTO. Applicant's attorney now believes this Petition is in allowable condition. Examiner Gregson, as well as Supervising Patent Examiner Bowler, are requested to contact Examiner Weider if any questions remain as to the allowability of this petition.

04/13/1998 MIVILLARI 08000069 023038 08533115  
01 FC:122 130.00 CH

Please add the following inventors:

Shane D. Mattaway  
826 Periwinkle Street  
Boca Raton, FL 33486

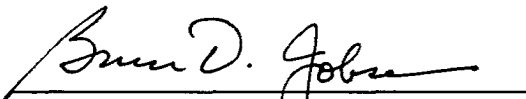
Craig B. Strickland  
5713 NW 65th Terrace  
Tamarac, FL 33321

Attached with this petition are the following:

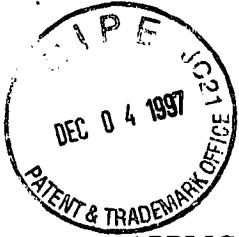
- A. A copy of the Statement of facts verified by the original-named inventor establishing when the error occurred without deceptive intent and the diligence with which this petition and amendment is being made with respect to these facts, the original signed copy having been submitted to the USPTO on April 17, 1997;
- B. A copy of the Declaration by each of the actual inventors as required under 37 CFR §1.63 as originally submitted on April 17, 1997; and
- C. Written assent of the assignee in the form of a Certificate under 37 CFR 3.73(b).

Payment of the \$130.00 fee for this petition, as required under 37 CFR §1.17(h), was paid with the submission of the original petition on April 17, 1997. If the fee is insufficient, the balance may be charged to the account of the undersigned, Deposit Account No. 02-3038. A duplicate of this sheet is enclosed.

Respectfully submitted,



Bruce D. Jobse, Esq.  
Reg. No. 33,518  
KUDIRKA & JOBSE, LLP  
One Beacon Street  
Boston, MA 02108  
(617) 367-4600



Attorney Docket No. N0003/7000

IN THE UNITED STATES PATENT AND TRADEMARK OFFICE

APPLICANT Glenn W. Hutton  
SERIAL NO.: 08/533,115  
FILED: September 25, 1995  
FOR: POINT-TO-POINT INTERNET PROTOCOL  
EXAMINER: R. Gregson  
ART UNIT: 2302

CLASSIFIED  
15-9-97  
2302

CERTIFICATE OF MAILING

I hereby certify that this correspondence is being deposited with the United States Postal Service as first class mail in an envelope addressed to: Assistant Commissioner for Patents, Washington, DC 20231, on December 2, 1997.

Anna Maria Keel  
(Typed or printed name of person mailing correspondence)

Anna Maria Keel  
(Signature of person mailing correspondence)

Assistant Commissioner for Patents  
Washington, D.C. 20231

**CERTIFICATE UNDER 37 C.F.R. 3.73(b)**

NetSpeak Corporation, a Florida corporation, certifies that it is the assignee of the entire right, title and interest in the patent application identified above by virtue of a chain of title from the inventor as evidenced by a first assignment dated November 27, 1995 from Glenn W. Hutton to the Internet Telephone Company, Reel 7981, Frame 0020, and a second assignment from the Internet Telephone Company to NetSpeak Corporation dated May 14, 1996, Reel 7981, Frame 0053, copies of which are attached.


The undersigned has reviewed all the documents in the chain of title of the patent application identified above and, to the best of undersigned's knowledge and belief, title is in the assignee identified above.

The undersigned is empowered to sign this certificate on behalf of the assignee and to consent to the addition of Shane D. Mattaway and Craig B. Strickland as inventors to the application.

I hereby declare that all statements made herein of my own knowledge are true, and that all statements made on information and belief are believed to be true; and further, that these statements are made with the knowledge that willful false statements, and the like so made, are

punishable by fine or imprisonment, or both, under Section 1001, Title 18 of the United States Code, and that such willful false statements may jeopardize the validity of the application or any patent issuing thereon.

11/26/97  
Date

  
\_\_\_\_\_  
Stephen R. Cohen  
Chief Executive Officer  
NetSpeak Corporation

H:\BDJ\N0003\7000\ASSENTAS.WPD

GP 2783



ATTORNEY'S DOCKET NO.: N0003/7000

IN THE UNITED STATES PATENT AND TRADEMARK OFFICE

APPLICANT: Glenn W. Hutton  
SERIAL NO.: 08/533,115  
FILED: September 25, 1995  
FOR: POINT-TO-POINT INTERNET PROTOCOL  
EXAMINER: Richard J. Gregson, Esq.  
ART UNIT: 2302

RECEIVED  
SEP 26 1995  
2302

CERTIFICATE OF MAILING UNDER 37 C.F.R. §1.8(a)

The undersigned hereby certifies that this document is being placed in the United States mail with first-class postage attached, addressed to Assistant Commissioner for Patents, Washington, DC 20231 on the 2nd day of December, 1997.

Anna Maria Keel  
Anna Maria Keel

Assistant Commissioner for Patents  
Washington, D.C. 20231

Sir/Madam:

Transmitted herewith for filing are the following documents:

- Certificate under 37 C.F.R. 3.73(b)
- Corrected Petition to Add to Originally Named Inventor(s)
- Copy of Statement of Facts
- Copy of Declaration

If the enclosed papers are considered incomplete, the Mail Room and/or the Assignment Branch is respectfully requested to contact the undersigned collect at (617) 367-4600, Boston, Massachusetts.

No fee is enclosed or believed due with this correspondence. Any fee may be charged to the account of the undersigned, Deposit Account No. 02-3038. A duplicate of this sheet is enclosed.

Respectfully submitted,

Bruce D. Jobse

Bruce D. Jobse, Esq.  
Reg. No.: 33,518  
KUDIRKA & JOBSE, LLP  
One Beacon Street  
Boston, Massachusetts 02108  
Tel.: (617) 367-4600



# DECLARATION AND POWER OF ATTORNEY FOR PATENT APPLICATION

As a below named inventor, I hereby declare that:

My residence, post office address and citizenship are stated below next to my name:

I believe I am an original, first and joint inventor the subject matter which is claimed and for which a patent is sought on the invention entitled **POINT-TO-POINT INTERNET PROTOCOL**, the specification of which was filed on September 25, 1995 under Attorney's Docket Number N0003/7000, now U.S. Patent Application Serial No. 08/533,115.

I hereby state that I have reviewed and understand the contents of the above identified patent application, including the claims as amended by any amendment referred to above.

I acknowledge the duty to disclose information which is material to the patentability of this application in accordance with 37 C.F.R. 1.56.

I hereby claim the benefit of foreign priority under 35 U.S.C. 119 of any foreign application(s) for patent or inventor's certificate having a filing date before that of the application the priority of which is claimed:

Prior Foreign Application(s):			Priority Claimed
_____	_____	_____	Yes ___ No ___
(Number)	(Country)	(Filing Date)	

I hereby claim the benefit of United States priority under 35 U.S.C. 120 of any United States application(s) listed below and, insofar as the subject matter of each of the claims of this application is not disclosed in a listed prior United States application in the manner provided by the first paragraph of 35 U.S.C. 112, I acknowledge the duty to disclose information material to the patentability of this application as defined in 37 C.F.R. 1.56 which occurred between the filing date of the prior application and the national or PCT international filing date of this application.

_____	_____	_____
(Application Serial #)	(Filing Date)	(Status)
_____	_____	_____
(Application Serial #)	(Filing Date)	(Status)
_____	_____	_____
(Application Serial #)	(Filing Date)	(Status)

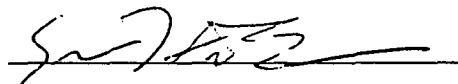
I hereby declare that all statements made herein of my own knowledge are true and that all statements made on information and belief are believed to be true; and further that these statements were made with the knowledge that willful false statements and the like so made are punishable by fine or imprisonment, or both, under 18 U.S.C. 1001 and that such willful false statements may jeopardize the validity of the application or any patent issued thereon.

POWER OF ATTORNEY: As a named inventor, I hereby appoint the following attorneys and/or agents to prosecute this application and transact all business in the Patent and Trademark Office connected therewith.

Bruce D. Jobse	Reg. No. 33,518	Paul E. Kudirka	Reg. No. 26,931
Arthur Z. Bookstein	Reg. No. 22,958	John F. Perullo	Reg. No. 36,265
Philip L. Conrad	Reg. No. 34,567	Steven G. Saunders	Reg. No. 36,265
Paul J. Cook	Reg. No. 20,280		

Send correspondence to Bruce D. Jobse, BOOKSTEIN & KUDIRKA, P.C., One Beacon Street, Boston, Massachusetts, 02108.

FULL NAME OF INVENTOR: Glenn W. Hutton

INVENTOR'S SIGNATURE:  DATE: 4-2-97

RESIDENCE: 9725 Hammocks Boulevard, #206, Miami, FL 33196  
CITIZENSHIP: Canada  
POST OFFICE ADDRESS: 9725 Hammocks Boulevard, #206, Miami, FL 33196

---

---

FULL NAME OF INVENTOR: Shane D. Mattaway

INVENTOR'S SIGNATURE: \_\_\_\_\_ DATE: \_\_\_\_\_

RESIDENCE: 826 Periwinkle, Boca Raton, FL 33486  
CITIZENSHIP: U.S.A.  
POST OFFICE ADDRESS: 826 Periwinkle, Boca Raton, FL 33486

---

---

FULL NAME OF INVENTOR: Craig B. Strickland

INVENTOR'S SIGNATURE: \_\_\_\_\_ DATE: \_\_\_\_\_

RESIDENCE: 5713 NW 65th Terrace, Tamarac, FL 33321  
CITIZENSHIP: Canada  
POST OFFICE ADDRESS: 5713 NW 65th Terrace, Tamarac, FL 33321

H:\BD\N0003\7000\DECL.WPD





# DECLARATION AND POWER OF ATTORNEY FOR PATENT APPLICATION

As a below named inventor, I hereby declare that:

My residence, post office address and citizenship are stated below next to my name:

I believe I am an original, first and joint inventor the subject matter which is claimed and for which a patent is sought on the invention entitled **POINT-TO-POINT INTERNET PROTOCOL**, the specification of which was filed on September 25, 1995 under Attorney's Docket Number N0003/7000, now U.S. Patent Application Serial No. 08/533,115.

I hereby state that I have reviewed and understand the contents of the above identified patent application, including the claims as amended by any amendment referred to above.

I acknowledge the duty to disclose information which is material to the patentability of this application in accordance with 37 C.F.R. 1.56.

I hereby claim the benefit of foreign priority under 35 U.S.C. 119 of any foreign application(s) for patent or inventor's certificate having a filing date before that of the application the priority of which is claimed:

Prior Foreign Application(s):			Priority Claimed	
_____	_____	_____	_____ Yes	_____ No
(Number)	(Country)	(Filing Date)		

I hereby claim the benefit of United States priority under 35 U.S.C. 120 of any United States application(s) listed below and, insofar as the subject matter of each of the claims of this application is not disclosed in a listed prior United States application in the manner provided by the first paragraph of 35 U.S.C. 112, I acknowledge the duty to disclose information material to the patentability of this application as defined in 37 C.F.R. 1.56 which occurred between the filing date of the prior application and the national or PCT international filing date of this application.

_____	_____	_____
(Application Serial #)	(Filing Date)	(Status)
_____	_____	_____
(Application Serial #)	(Filing Date)	(Status)
_____	_____	_____
(Application Serial #)	(Filing Date)	(Status)

I hereby declare that all statements made herein of my own knowledge are true and that all statements made on information and belief are believed to be true; and further that these statements were made with the knowledge that willful false statements and the like so made are punishable by fine or imprisonment, or both, under 18 U.S.C. 1001 and that such willful false statements may jeopardize the validity of the application or any patent issued thereon.

POWER OF ATTORNEY: As a named inventor, I hereby appoint the following attorneys and/or agents to prosecute this application and transact all business in the Patent and Trademark Office connected therewith.

Bruce D. Jobse	Reg. No. 33,518	Paul E. Kudirka	Reg. No. 26,931
Arthur Z. Bookstein	Reg. No. 22,958	John F. Perullo	Reg. No. 36,265
Philip L. Conrad	Reg. No. 34,567	Steven G. Saunders	Reg. No. 36,265
Paul J. Cook	Reg. No. 20,280		

Send correspondence to Bruce D. Jobse, BOOKSTEIN & KUDIRKA, P.C., One Beacon Street, Boston, Massachusetts, 02108.

FULL NAME OF INVENTOR: Glenn W. Hutton

INVENTOR'S SIGNATURE: \_\_\_\_\_ DATE: \_\_\_\_\_

RESIDENCE: 9725 Hammocks Boulevard, #206, Miami, FL 33196  
CITIZENSHIP: Canada  
POST OFFICE ADDRESS: 9725 Hammocks Boulevard, #206, Miami, FL 33196

---


FULL NAME OF INVENTOR: Shane D. Mattaway

INVENTOR'S SIGNATURE:  DATE: 1/3/97

RESIDENCE: 826 Periwinkle, Boca Raton, FL 33486  
CITIZENSHIP: U.S.A.  
POST OFFICE ADDRESS: 826 Periwinkle, Boca Raton, FL 33486

---

FULL NAME OF INVENTOR: Craig B. Strickland

INVENTOR'S SIGNATURE:  DATE: 1/3/97

RESIDENCE: 5713 NW 65th Terrace, Tamarac, FL 33321  
CITIZENSHIP: Canada  
POST OFFICE ADDRESS: 5713 NW 65th Terrace, Tamarac, FL 33321

H:\BD\N0003\7000\DECL.WPD



ATTORNEY DOCKET NO. N0003/7000

IN THE UNITED STATES PATENT AND TRADEMARK OFFICE

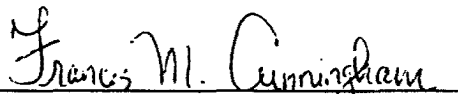
Applicant: Glenn W. Hutton  
Serial No.: 08/533,115  
Filed: September 25, 1995  
For: POINT-TO-POINT INTERNET PROTOCOL  
Examiner: --  
Art Unit: 2302

RECEIVED  
SEP 29 1995  
2302

CERTIFICATE OF MAILING UNDER 37 C.F.R. §1.8(a)

The undersigned hereby certifies that this document is being placed in the United States mail with first-class postage attached, addressed to Assistant Commissioner for Patents, Washington, DC 20231 on

April 17, 1997

  
Frances M. Cunningham

Assistant Commissioner for Patents  
Washington, D.C. 20231

STATEMENT OF FACTS IN SUPPORT OF PETITION  
TO ADD INVENTORS UNDER 37 CFR §1.48(C)

Statement of Facts

1. On September 25, 1995, patent application serial number 08/533,155, entitled "Point-to-Point Internet Protocol" was filed on my behalf, as sole inventor, by Anthony J. Natoli, Esq., Reg. No. 36,223, of the law firm of Dilworth & Barrese, Uniondale, New York, NY.
2. On November 27, 1995 I assigned all right, title and interest in and to the patent application to the Internet Telephone Company, a Florida corporation having a place of business at One South Ocean Boulevard, Suite 305, Boca Raton, Florida 33432.
3. In March of 1996, NetSpeak Corporation, parent corporation of the Internet Telephone Company, retained the services of Bruce D. Jobse, Esq., Reg. No. 33,518, of the law firm of Bookstein & Kudirka, Boston, Massachusetts, to prosecute

the above-identified application.

4. On April 5, 1996 a preliminary amendment to the patent application was filed adding claims 21-53, some of which were directed to subject matter previously disclosed but not yet claimed.

5. I became aware of the preliminary amendment and the additional claims during a telephone conversation with attorney Bruce D. Jobse sometime in late November 1996.

6. On December 11, 1996 I received a copy of the above-mentioned preliminary amendment filed April 5, 1996. I acknowledge that both Shane D. Mattaway and Craig B. Strickland contributed to the subject matter of at least one currently pending claim of the above-identified application. The necessity of naming Shane D. Mattaway and Craig B. Strickland as inventors was discovered sometime between my subsequent review of the copy of the preliminary amendment and the date of this Statement of Facts. A diligent effort has been made to correct this error.

I hereby declare that all statements made herein of my own knowledge are true and that statements made on information and belief are believed to be true and further that the statements were made with the knowledge that willful false statements and the like so made are punishable by fine or imprisonment, or both under Section 1001 of Title 18 of United States Code, and that such willful, false statements may jeopardize the validity of the application or any patents issued therefrom.



Glenn W. Hutton

4-2-97

Date

~~4-2-97 5743 NW 65th Terrace, Tamarac, FL 33321~~

SA 9725 HANNOCKS BLVD #206

Citizen: Canada

MIAMI, FL. 33196

H:\BDJVN000317000\STMTFACT.WPD



GAU-2302

PATENT: N0003/7000

IN THE UNITED STATES PATENT AND TRADEMARK OFFICE

#15  
EA (3)  
1/8/98

Applicant: Glenn W. Hutton  
Serial No.: 08/533,115  
Filed: September 25, 1995  
For: POINT-TO-POINT INTERNET PROTOCOL  
Examiner: Richard J. Gregson, Esq.  
Art Unit: 2302

KUDIRKA & JOBSE, LLP  
One Beacon Street  
Boston, MA 02108

RECEIVED  
DEC 11 57  
GROUP 2600

CERTIFICATE OF MAILING

I hereby certify that the following Petition is being deposited with the United States Postal Service as first class mail in an envelope addressed to the Assistant Commissioner for Patents, Washington, D.C. 20231 on December 2, 1997.

Bruce D. Jobse

Assistant Commissioner for Patents  
Washington, D.C. 20231

Sir/Madam:

PETITION FOR EXTENSION OF TIME

Please extend the time for response to the Office Action dated June 2, 1997 for Three months to December 2, 1997. Enclosed is a check in the amount of \$950.00 to cover the cost of the extension.

12/09/1997  
01 FC:117

The Commissioner is hereby authorized to charge any other fees under 37 C.F.R. §1.16 and 1.17 that may be required, or credit any overpayment, to our Deposit Account No. 02-3038.

Respectfully submitted,

Bruce D. Jobse, Esq.  
Reg. No. 33,518  
KUDIRKA & JOBSE, LLP  
One Beacon Street  
Boston, MA 02108  
(617) 367-4600



ATTORNEY DOCKET NO. N0003/7000

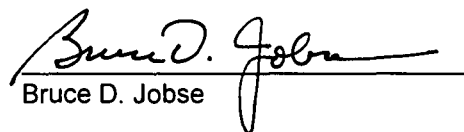
IN THE UNITED STATES PATENT AND TRADEMARK OFFICE

Applicant: Glenn W. Hutton  
Serial No.: 08/533,115  
Filed: September 25, 1995  
For: POINT-TO-POINT INTERNET PROTOCOL  
Examiner: Richard J. Gregson, Esq.  
Art Unit: 2302

#16  
Decl  
w/att  
11/8/98

CERTIFICATE OF MAILING

I hereby certify that the following correspondence is being deposited with the United States Postal Service as first class mail in an envelope addressed to the Assistant Commissioner for Patents, Washington, D.C. 20231 on December 2, 1997.

  
Bruce D. Jobse

Assistant Commissioner for Patents  
Washington, D.C. 20231

**DECLARATION OF PRIOR INVENTION IN THE UNITED STATES TO OVERCOME  
CITED PATENT UNDER 37 CFR 1.131**

Sir/Madam:

This declaration is to establish completion of the invention in this application in the United States at a date prior to May 23, 1995, the effective date of prior art patent 5,581,552, cited by the Examiner. The undersigned Declarant is the named Inventor in the above-identified patent application. The Declarant's statements set forth below establishes conception of the invention prior to the effective date of the reference coupled with due diligence from prior to the effective date to filing of the application. Exhibits A and B are submitted herewith to support the Declarant's statements. This Declaration is submitted prior to final rejection of the application.

1. I am the named inventor in the United States Patent Application 08/533,115, filed September 25, 1995, entitled "POINT-TO-POINT INTERNET PROTOCOL".

2. In the early morning hours on a date prior to May of 1995, I conceived of the subject matter disclosed in the above-identified patent application and memorialized the concept in a word processing document entitled "webph.doc" on my computer system, a copy of which is attached hereto as Exhibit A, including a printout of the file properties, the dates of creation and last modification of which have been redacted.

3. The various aspects of the inventive subject matter are set forth in sections 1-5 of Exhibit A, particularly sections 2-4.

4. I authored and edited the document into its final format on the same date the document was created.

5. A number of weeks after the conception of the inventive subject matter, and while refining the inventive concepts, I helped form, and became a principal in the Internet Telephone Company, a Florida Corporation having a place of business at One South Ocean Boulevard, Suite 305, Boca Raton, Florida 33432.

6. Following formation of the Internet Telephone Company, a detailed design specification entitled "Internet Telephone Company Webphone Design", a copy of which is attached hereto as Exhibit B, was generated to memorialize an implementation of the inventive concepts and provided the basis from which coding and testing of a working embodiment of the inventive concepts continued diligently until the filing date of this patent application, September 25, 1995.

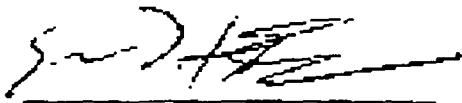
I hereby declare that all statements made herein of my own knowledge are true and that all statements made on information and belief are believed to be true; and further that these statements were made with the knowledge that willful false statements and the like so made are punishable by fine or imprisonment, or both, under

08/533,115

-3-

N0003/7000

Section 1001 of Title 18 of the United States Code, and that such willful false statements may jeopardize the validity of the application or any patent issued thereon.



Glenn W. Hutton

12-2-97

Date

Residence: 9725 Hammocks Boulevard, #206  
Miami, Florida 33196

Citizenship: CANADA  
Post Office Address: 9725 Hammocks Boulevard, #206  
Miami, Florida 33196

H:\BDJW0003\7000\DLPR\INV.WPD



Super Phone mail  
Global mail

Concept:

A multi purpose internet mailer package, providing; E-mail, voice mail/answering machine, real-time phone connections over the internet and IRC real-time conversations. and picture mail and text to speech.

\* Also users that do not have a sound card might be able to hear sound files played through their PC speaker using the speaker sound driver. \*\*CHECK on file size\*\*

1. Basic E-mail package self explanatory.
2. Voice mail/Answering machine.

When the program is first installed on the users machine their are prompted to record a short out going message. The message is store on the POP server with a standard name such as outmsg.au. When another user calls via the internet phone the users is greeted with the msg and may then leave a voice message for the person they are trying to reach.

If the user they are trying to reach is logged onto the network the users software would automatically log onto the POP server and either ren the outmsg file or delete it from the server. This way when another user tries to call him the msg would not be found and an e-mail would be sent to the receiver of the call. The mail software would then send back to the calling party the IP address of the called party and a connection could be made.

3. Real - Time Phone connections

Just like in the real world sometimes you call and no one is home. The same concept applies here. The setup is a follows;

The party to be called logs onto the network and loads software. Approximately every 30 seconds it polls the POP server to see if anyone has sent a msg (like a query with a small amount of data i.e. the callers IP address). If the program finds such a msg it response with a msg back to the caller POP server with its IP address. Now both parties have each others IP addresses and a real-time connection can be made.

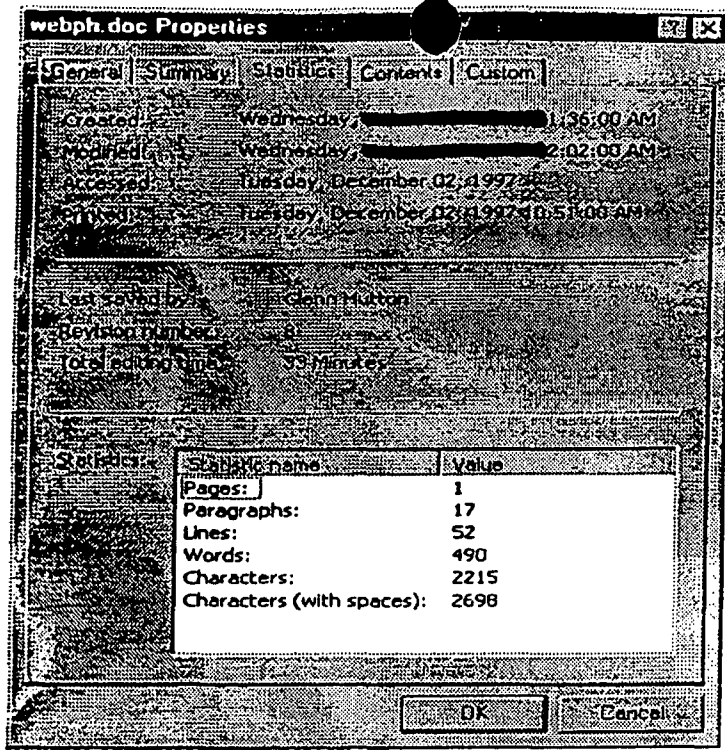
4. Real - Time Phone connections 2

Similar to above however involves a dedicated server or possible network of servers. The setup is as follows;

The party logs onto the network and loads the software. Similar to the POP server concept the phone software will send a message to the connection server providing the server with the users information, ie, IP address, user name and other user information. A record is kept on the server set with a flag identifying that the user is on line. Again, like the POP server concept the email address of the user is the primary identification for other users to find if a user is on or off line. This interface like the POP server concept does not require the user to be permently connected to the server.

5. Text to speech for reading E-mail.

Just a simple plug in (Viewer) as most sound cards come with the software.





*R. Gregg*  
#17 B  
1/8/98

ATTORNEY DOCKET NO. N0003/7000

IN THE UNITED STATES PATENT AND TRADEMARK OFFICE

Applicant: Glenn W. Hutton  
Serial No.: 08/533,115  
Filed: September 25, 1995  
For: POINT-TO-POINT INTERNET PROTOCOL  
Examiner: Richard J. Gregson, Esq.  
Art Unit: 2302

CERTIFICATE OF MAILING

I hereby certify that the following correspondence is being deposited with the United States Postal Service as first class mail in an envelope addressed to the Assistant Commissioner for Patents, Washington, D.C. 20231 on December 2, 1997.

*Bruce D. Jobse*  
Bruce D. Jobse

Assistant Commissioner for Patents  
Washington, D.C. 20231

Sir:

RECEIVED  
DEC 11 57  
GA-302 2300

AMENDMENT

In the Title

Please delete the title as filed and insert -- Method and Apparatus for Establishing Point-to-Point Communications Over a Computer Network --.

In the Specification

01/23/1998 KDUNCAN 00000072 DAB-200065 08533115  
01 FC:202 287.00 CH  
02 FC:203 165.00 CH

Page 1, line 20, after "interfacing" insert --to--.

Page 6, line 18, change "by" to --to--.

Page 7, line 6, change "read-only" to --random access--;

line 14, change "other" to --another--.

Page 12, line 17, change "the connection server 26" to --a connection service

*B* *1-*

provider--.

Page 13, line 6, change "the connection server 26" to --a connection service provider--.

In the Claims

Please amend the claims as follows:

22. (Amended) A computer program product for use with a computer system, the computer system having first processor operatively coupled to a second processor [and second processors] and a server [operatively coupled] over a computer network, the computer program product comprising:

a computer useable medium having program code means embodied in the medium for establishing a point-to-point communications link between the first processor and a second processor over a computer network, the medium further comprising:

program code means for transmitting an E-mail signal comprising a network protocol address [from] of the first processor to the second processor [server] over the computer network;

program code means for receiving a second network protocol address from the second processor over the computer network; and

program code means, responsive to the second network protocol address, for establishing a point-to-point communication link between the first processor and the second processor over a computer network.

42. (Amended) The method of claim 41 wherein [the elements generated in steps A and B are graphic elements and] the step of establishing a [point-to-communication] point-to-point link as described in step C is performed in response to a user manipulating the graphic elements on the graphic user interface.

Please add the following claims:

*subC6* →

54. A method of locating a user over a computer network comprising the steps of:

- a. maintaining an Internet accessible list having a plurality of entries, each entry comprising an electronic mail address and a corresponding Internet protocol address for a process currently connected to the Internet; and
- b. in response to identification of one of the list entries by a requesting process, providing one of the electronic mail address and the corresponding Internet protocol address of the identified entry to the requesting process.

*B*

55. A method for locating users having dynamically assigned network protocol addresses over a computer network, the method comprising the steps of:

- a. maintaining in a computer memory, a network accessible compilation of entries, each entry comprising a network protocol address and a corresponding identifier for a user connected to the computer network;
- b. in response to identification of one of the entries by a requesting process providing one of the identifier and the network protocol address to the requesting process.

56. The method of claim 55 further comprising the step of:

- c. modifying the compilation of entries.

57. The method of claim 56 wherein step c further comprises:

- c.1 adding an entry to the compilation upon the occurrence of a predetermined event.

58. The method of claim 57 wherein the predetermined event comprises notification by a user process of an assigned network protocol address.

59. The method of claim 56 wherein step c further comprises:  
c.1 deleting an entry from the compilation upon the occurrence of a predetermined event.

60. A computer program product for use with a server apparatus operatively coupled over a computer network to one or more computer processes, the computer program product comprising a computer usable medium having program code embodied in the medium the program code comprising:

a. program code configured to maintain, in a computer memory, a network accessible compilation of entries, each entry comprising a network protocol address and a corresponding identifier for a process connected to the computer network; and

b. program code responsive to identification of one of the entries by a requesting process and configured to provide one of the identifier and the network protocol address to the requesting process.

61. The computer program product of claim 60 further comprising:

c. program code configured to modify the compilation of entries.

62. The computer program product of claim 61 wherein program code configured to modify comprises:

c.1 program code configured to add an entry to the compilation upon the occurrence of a predetermined event.

63. The computer program product of claim 62 wherein the predetermined event comprises notification by a process of an assigned network protocol address.

64. The computer program product of claim 60 wherein step c further

comprises:

~~c.1 program code configured to delete an entry from the compilation upon the occurrence of a predetermined event.~~

65. A computer program product for use with a server operatively coupled over a computer network to a plurality of processes, the computer program product comprising a computer usable medium having program code embodied thereon the program code comprising:

a. program code configured to receive the current network protocol address of one of the processes coupled to the network;

b. program code configured to receive an identifier associated with said one process, and

c. program code configured to receive queries for one of the network protocol address and the associated identifier of said one process from other processes over the computer network.

*subc.1*  
66. A computer program product for use with a computer system, the computer system including a first process operatively coupled over a computer network to a second process and a server process, the computer program product comprising a computer usable medium having computer readable program code embodied therein, the program code means comprising:

a. program code configured to access a directory database, the database having a network protocol address for a plurality of processes having on-line status with respect to the computer network; and

b. program code responsive to one of the network protocol addresses and configured to establish a point-to-point communication link from the first process to the second process over the computer network.

67. In a first computer process operatively coupled over a computer network to a second process and an address server, a method of establishing a point-to-point communication between the first and second processes comprising the steps of:

- A. querying the address server as to whether the second process is connected to the computer network;
- B. receiving a network protocol address of the second process from the address server, when the second process is connected to the computer network; and
- C. in responsive to the network protocol address of the second process, establishing a point-to-point communication link with the second process over the computer network.

68. In a first computer process operatively coupled over a computer network to a second process and an E-mail server, a method of establishing a point-to-point communication between the first and second processes comprising the steps of:

- A. transmitting an E-mail signal comprising a network protocol address of the first process to the second process over the computer network;
- B. receiving a second network protocol address from the second process over the computer network; and
- C. in responsive to the second network protocol address, establishing a point-to-point communication link between the first process and the second process over a computer network.

#### REMARKS

Applicant has considered carefully the Office Action dated June 2, 1997 and the references cited therein. In response, the title, specification, and claims have been amended. Applicant respectfully requests reexamination of the application.

The title of the application has now been changed to "METHOD AND APPARATUS FOR ESTABLISHING POINT-TO-POINT COMMUNICATIONS OVER A



COMPUTER NETWORK. Applicant asserts that the title as amended is indicative of the invention to which the claims are directed.

Regarding the multiple information disclosures submitted prior to examination, many of the submitted references were located during patentability searches not performed by applicant's current counsel. Applicant's current counsel submitted such references under the continuing duty of candor under 37 C.F.R. §§56, 1.97, 1.98. The Applicant is relying on the Examiner's expertise to determine the relevance of the references to the claimed subject matter.

As requested by the Examiner, the applicant has checked the specification for minor errors and has, in response, amended the specification as set forth herein. No new matter is believed to be added by these changes to the specification.

Claim 22 has been amended to conform the claim language with the specification. Such amendments are not required to distinguish the claimed subject matter over any of the cited references, whether considered singularly or in combination.

Claim 42 has been amended to correct a grammatical error and any potential problems under 37 C.F.R. §112, second paragraph. Such amendment is not required to distinguish the claimed subject matter over any of the cited references, whether considered singularly or in combination.

Applicant submits herewith a declaration of prior invention under 37 CFR 1.131 to overcome the rejection of all claims under 35 U.S.C. §103 as being unpatentable over Civanlar et al. in view of Morgan et al. and/or further in view of December et al. The declaration is submitted with a facsimile signature of the declarant inventor. The original signed declaration will be submitted as soon as it becomes available. In light of the declaration and accompanying exhibits, all rejections based on the Civanlar et al. reference are deemed moot.

In addition, Applicant has the following remarks. One of the major factors

inhibiting dynamic communications over the Internet, and other computer networks, is the inability to obtain the current dynamically assigned network protocol address of a user process connected to the network. This problem is analogous to trying to call someone whose telephone number changes after each call. Applicant's invention provides techniques for determining the current dynamically assigned network protocol address of a user process connected to the network. The first technique utilizes a dedicated server which acts as a network address/information directory from which calling processes can obtain information. When a first process connects to the network, the process logs-on to the server and provides the server with the network protocol address under which the first process is currently operating. A second process wishing to establish communications with the first process, connects to the server and request the network protocol address under which the first process is currently operating. Upon receipt of the network protocol address of the first process, the second process establishes communications with the first process directly, without any intervention from the address/ information server.

The Examiner has repeatedly indicated that Civanlar et al. in view of Morgan et al. teach an address server and database utilized to initiate communications between two nodes. Conversely, in the present invention, communications between two nodes, e.g. processes, are initiated by solely by one of the processes. The address server may have optionally supplied address information to one of the processes, but the address server does not establish the point-to-point communication connection between the nodes. Applicant has reviewed Civanlar et al. in view of Morgan et al. and has found no disclosure or suggestion of this first claimed technique whether the references are considered singularly or in combination.

Applicant's invention provides a second techniques for determining the current dynamically assigned network protocol address of a user process connected to the network. In the second technique, a first process wishing to establish communications with a second process, sends, via E-mail, the network protocol address under which

the first process is currently operating to the second process. Upon receipt of the E-mail message, the second process sends to the first process, via E-mail, the network protocol address under which the second process is currently operating. Upon receipt of the network protocol address of the second process, the first process establishes communications with the second process directly, without any intervention from the address/ information server. This second technique may be used in addition to or in place of the first technique. As with the first technique, communications between two nodes, e.g. processes, are initiated by solely by one of the processes. The address server does not establish the point-to-point communication connection between the nodes. Applicant has reviewed Civanlar et al. in view of Morgan et al. and further in view of December et al. and has found no disclosure or suggestion of this second claimed technique whether the references are considered singularly or in combination.

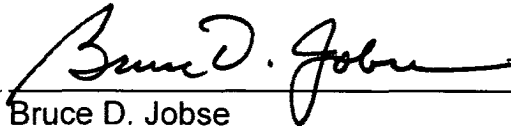
Applicant respectfully traverses the rejection of claims 32-42 and 43-53 under 35 U.S.C. §103 as being unpatentable over Civanlar et al. in view of Morgan et al. and further in view of December et al. Claims 32-42 are directed to a method for establishing a point-to-point communication link from a caller processor to a callee processor over a computer network by associating graphic elements representing communication line and a first callee processor. Claims 43-53 essentially comprise a computer program product claim counterparts to claims 32-42. Applicant has reviewed the cited references in detail and can find no suggestion or disclosure of generating graphic elements representing a communication line or a callee processor or establishment of a point-to-point communication link by associating the graphic element.

Applicant submits herewith new claims 54-68 to more particularly point out and distinctly claim the subject matter which the Applicant regards as the invention. All claims are believed allowable over any of the references cited by the Applicant, whether considered singularly or in combination. Accordingly, Applicant believes this application is in condition for allowance and a notice to that effect is respectfully requested. If the

Examiner has any questions regarding this amendment or the application in general he is invited to call the Applicant's attorney at the number listed below.

The Commissioner is hereby authorized to charge any other fees under 37 C.F.R. §1.16 and 1.17 that may be required, or credit any overpayment, to our Deposit Account No. 20-0065.

Respectfully submitted,



Bruce D. Jobse  
Reg. No. 33,518  
KUDIRKA & JOBSE, P.C.  
One Beacon Street  
Boston, MA 02108  
(617) 367-4600

GP 2302  
\$



IN THE UNITED STATES PATENT AND TRADEMARK OFFICE

Applicant: Glenn W. Hutton  
Serial No.: 08/533,115  
Filed: September 25, 1995  
For: POINT-TO-POINT INTERNET PROTOCOL  
Examiner: Richard J. Gregson, Esq.  
Art Unit: 2302

RECEIVED  
DEC 11 97  
GROUP 2600

Assistant Commissioner for Patents  
Washington, D.C. 20231

CERTIFICATE OF MAILING UNDER 37 C.F.R. §1.8(a)

The undersigned hereby certifies that this document is being placed in the United States mail with first-class postage attached, addressed to Assistant Commissioner for Patents, Washington, DC 20231 on the 2nd day of December, 1997.

Bruce D. Jobse

AMENDMENT TRANSMITTAL LETTER

Sir/Madam:

Transmitted herewith for filing in the above identified patent application are the following papers:

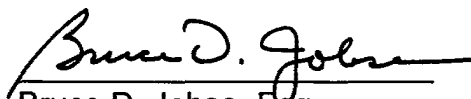
- [X] Amendment
- [X] Petition for 3-Month Extension of Time
- [X] Check in the Amount of \$950.00
- [X] Declaration Under 37 CFR 1.131
- [X] Exhibits A and B

The fee is calculated as follows:

		Previously Paid				
Total Claims	68	- 53	=	15	X	\$22.00 = 330.00
Independent Claims	19	- 12	=	7	X	\$82.00 = 574.00
<b>TOTAL</b>						<b>\$904.00</b>

The Commissioner is hereby authorized to charge any other fees under 37 C.F.R. §§1.16 and 1.17 that may be required, or credit any overpayment, to our Deposit Account No. 02-3038.

Respectfully submitted,



Bruce D. Jobse, Esq.  
Reg. No. 35,518  
KUDIRKA & JOBSE, LLP  
One Beacon Street  
Boston, MA 02108  
(617) 367-4600

December 2, 1997

08/533115



UNITED STATES DEPARTMENT OF COMMERCE  
Patent and Trademark Office

Address: COMMISSIONER OF PATENTS AND TRADEMARKS  
Washington, D.C. 20231

28

APPLICATION NO.	FILING DATE	FIRST NAMED INVENTOR	ATTORNEY DOCKET NO.
087533,115	09/25/95	HUTTON	649-2

LM21/0414

BOOSTEIN & KUDIRKA, PC  
ONE BEACON STREET  
BOSTON MA 02108

EXAMINER  
RINEHART, M


ART UNIT      PAPER NUMBER  
2756

DATE MAILED:      04/14/98

Please find below and/or attached an Office communication concerning this application or proceeding.


Commissioner of Patents and Trademarks

See Attachment.

  
**MARK H. RINEHART  
PRIMARY EXAMINER**

# Office Action Summary

Application No. <b>08/533,115</b>	Applicant(s) <b>Hutton et al.</b>
Examiner <b>Mark H. Rinehart</b>	Group Art Unit <b>2756</b>



Responsive to communication(s) filed on 12/4/97

This action is **FINAL**.

Since this application is in condition for allowance except for formal matters, **prosecution as to the merits is closed** in accordance with the practice under *Ex parte Quayle*, 1935 C.D. 11; 453 O.G. 213.

A shortened statutory period for response to this action is set to expire 30 days month(s), or thirty days, whichever is longer, from the mailing date of this communication. Failure to respond within the period for response will cause the application to become abandoned. (35 U.S.C. § 133). Extensions of time may be obtained under the provisions of 37 CFR 1.136(a).

### Disposition of Claims

Claim(s) 1-68 is/are pending in the application.

Of the above, claim(s) \_\_\_\_\_ is/are withdrawn from consideration.

Claim(s) \_\_\_\_\_ is/are allowed.

Claim(s) \_\_\_\_\_ is/are rejected.

Claim(s) \_\_\_\_\_ is/are objected to.

Claims 1-68 are subject to restriction or election requirement.

### Application Papers

See the attached Notice of Draftsperson's Patent Drawing Review, PTO-948.

The drawing(s) filed on \_\_\_\_\_ is/are objected to by the Examiner.

The proposed drawing correction, filed on \_\_\_\_\_ is  approved  disapproved.

The specification is objected to by the Examiner.

The oath or declaration is objected to by the Examiner.

### Priority under 35 U.S.C. § 119

Acknowledgement is made of a claim for foreign priority under 35 U.S.C. § 119(a)-(d).

All  Some\*  None of the CERTIFIED copies of the priority documents have been  
 received.

received in Application No. (Series Code/Serial Number) \_\_\_\_\_.

received in this national stage application from the International Bureau (PCT Rule 17.2(a)).

\*Certified copies not received: \_\_\_\_\_

Acknowledgement is made of a claim for domestic priority under 35 U.S.C. § 119(e).

### Attachment(s)

Notice of References Cited, PTO-892.

Information Disclosure Statement(s), PTO-1449, Paper No(s). 2,4,5,13

Interview Summary, PTO-413

Notice of Draftsperson's Patent Drawing Review, PTO-948

Notice of Informal Patent Application, PTO-152

# FILE COPY

--- SEE OFFICE ACTION ON THE FOLLOWING PAGES ---



Art Unit: 2756

**DETAILED ACTION**

***Election/Restriction***

1. Restriction to one of the following inventions is required under 35 U.S.C. 121:
  - I. Claims 1-4, 6-11, 21, 26-64, and 66-67, drawn to a system, apparatus, and method for querying a database server from a first computer to determine the status and identifier associated with a second computer within the operating network for establishing a connection, classified in class 395, subclass 200.58.
  - II. Claims 12-16, 19-20, 22-25, and 68, drawn to a system, apparatus, and method for directing an electronic mail message from a first computer through a network to a second computer for initiating the second computer to directly message the first computer with its address, classified in class 395, subclass 200.37.
  - III. Claims 17-18, drawn to an apparatus for initiating an electronic mail transmission, classified in class 395, subclass 300.36.
  - IV. Claim 65, drawn to a method for updating and querying a status database server, classified in class 395, subclass 200.54.
  
2. The inventions are distinct, each from the other because of the following reasons:

Inventions I, II, III, and IV are related as subcombinations disclosed as usable together in a single combination. The subcombinations are distinct from each other if they are shown to be separately usable. In the instant case, invention I has separate utility such as allowing a communicating computer to establish the identifier and online status of a second computer with identifying itself to the second computer to accomodate privacy concerns; invention II has

**FILE COPY**

Art Unit: 2756

separate utility such as allowing a called computer to determine the sender of a connection request and directly respond or refuse a connection with the calling computer; invention III has separate utility such as preparing a mail message for electronic transmission to a distribution mail server; and invention IV has separate utility such as monitoring status of computers on a network system to enable management of a network system. See MPEP § 806.05(d).

3. Claim 5 link(s) inventions I and II. The restriction requirement between the linked inventions is subject to the nonallowance of the linking claim(s), claim 5. Upon the allowance of the linking claim(s), the restriction requirement as to the linked inventions shall be withdrawn and any claim(s) depending from or otherwise including all the limitations of the allowable linking claim(s) will be entitled to examination in the instant application. Applicant(s) are advised that if any such claim(s) depending from or including all the limitations of the allowable linking claim(s) is/are presented in a continuation or divisional application, the claims of the continuation or divisional application may be subject to provisional statutory and/or nonstatutory double patenting rejections over the claims of the instant application. Where a restriction requirement is withdrawn, the provisions of 35 U.S.C. 121 are no longer applicable. *In re Ziegler*, 44 F.2d 1211, 1215, 170 USPQ 129, 131-32 (CCPA 1971). See also MPEP § 804.01.

4. Because these inventions are distinct for the reasons given above and have acquired a separate status in the art as shown by their different classification, restriction for examination purposes as indicated is proper.

Art Unit: 2756

5. Because these inventions are distinct for the reasons given above and the search required for each of Groups I-IV is not required for each of the other Groups, restriction for examination purposes as indicated is proper.

6. Because these inventions are distinct for the reasons given above and have acquired a separate status in the art because of their recognized divergent subject matter, restriction for examination purposes as indicated is proper.

7. A telephone call was made to Bruce D. Jobse, Reg. # 33,518, on 4/10/98 to request an oral election to the above restriction requirement, but did not result in an election being made.

Applicant is advised that the reply to this requirement to be complete must include an election of the invention to be examined even though the requirement be traversed (37 CFR 1.143).

8. Applicant is reminded that upon the cancellation of claims to a non-elected invention, the inventorship must be amended in compliance with 37 CFR 1.48(b) if one or more of the currently named inventors is no longer an inventor of at least one claim remaining in the application. Any amendment of inventorship must be accompanied by a petition under 37 CFR 1.48(b) and by the fee required under 37 CFR 1.17(i).

9. The Examiner notes that the disclosed inventions are rather complex in some of the details of the embodiments disclosed and claimed. While an election is required at this time, the Examiner would be willing to consider restriction of the invention based upon different groupings

Art Unit: 2756

should the Applicant wish to propose a different grouping of the claims for examination. An interview to such effect would be entertained by the Examiner if it would aid in establishing a more acceptable grouping of the claims for examination in order to advance prosecution of the application.


10. Any inquiry concerning this communication or earlier communications from the examiner should be directed to Primary Examiner Rinehart whose telephone number is (703) 305-4815. The examiner can normally be reached on Monday through Thursday from 8:00 AM - 5:30 PM. The examiner can also be reached on alternate Fridays.

If attempts to reach the examiner by telephone are unsuccessful, the examiner's supervisor, Supervisory Primary Examiner Frank J. Asta, can be reached on (703) 305-3817. The fax phone number for the Electrical Examining Technology Center is (703) 308-9051.

Any inquiry of a general nature or relating to the status of this application should be directed to the Group receptionist whose telephone number is (703) 305-3900.

Mark H. Rinehart  
Primary Examiner  
Art Unit 2756



  
**MARK H. RINEHART  
PRIMARY EXAMINER**

Attachment       #18      

**The drawings submitted with this application were declared informal by the applicant. Accordingly they have not been reviewed by a draftsman at this time. When formal drawings are submitted, the draftsman will perform a review.**

**Direct any inquires concerning drawing review to the Drawing Review Branch (703) 305-8404.**

#2

Sheet 1 of

Form PTO-1449 U.S. DEPARTMENT OF COMMERCE PATENT AND TRADEMARK OFFICE INFORMATION DISCLOSURE STATEMENT BY APPLICANT (Use several sheets if necessary)	ATTY. DOCKET NO. 649-2	SERIAL NO. 08/533,115
	APPLICANT Glenn V. Hutton	
	FILING DATE September 25, 1995	GROUP Art Unit 27



U.S. PATENT DOCUMENTS

EXAMINER INITIALS	DOCUMENT NUMBER	DATE	NAME	CLASS	SUBCLASS	FILING IF APPRO
RR	5 1 5 0 3 6 0	9/22/92	Perlman et al.			
	5 2 0 4 6 6 9	4/20/93	Dorfe et al.			
	5 2 2 4 0 9 5	6/29/93	Moest et al.			
	5 2 9 1 5 5 4	3/1/94	Morales			
	5 3 0 9 4 3 3	5/3/94	Cidon et al.			
	5 3 2 1 8 1 3	6/14/94	McMillen et al.			
	5 3 5 7 5 7 1	10/18/94	Berwart			
RR	5 4 0 0 3 3 5	3/21/95	Yanada			

FOREIGN PATENT DOCUMENTS

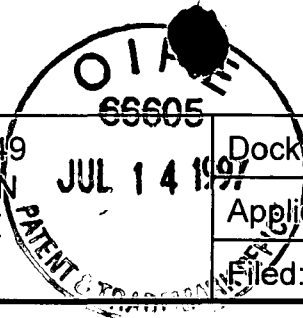
DOCUMENT NUMBER	DATE	COUNTRY	CLASS	SUBCLASS	TRANSLAT YES

OTHER DOCUMENTS (Including Author, Title, Date, Pertinent Pages, Etc.)


EXAMINER <b>MARK H. RINEHART</b> PRIMARY EXAMINER	DATE CONSIDERED 4/8/98
---	---------------------------

EXAMINER: Initial if citation considered, whether or not citation is in conformance with MPEP 609; Draw line through citation if not in conformance and not considered. Include copy of this form with next communication to applicant.

#13



Form PTO-1449 INFORMATION DISCLOSURE STATEMENT	Docket No.: N0003/7000	Serial No. 08/533,115
	Applicant: Glenn W. Hutton	
	Filed: September 25, 1995	Group: 2302 2756

U.S. Patent Documents

Ex.	Doc. No.	Date	Name	Class	Subcl.	Filed
MR	5 4 2 5 0 2 8	06/13/95	K.H. Britton et al.	—	—	07/16/92

RECEIVED  
AUS-1 97  
GROUP 2600

Foreign Patent Documents

Ex.	Doc. No.	Date	Name	Class	Subcl.	Filed
EP	A2 0 4 5 5 4 0 2	06/11/91	J.C. Wu	—	—	23/04/91
EP	A2 0 5 5 6 0 1 2	18/08/93	H. Wada et al.	—	—	09/02/93
WO	9 2 1 9 0 5 4	29/10/92	E. Ferdinand et al.	—	—	10/04/92

MR

OTHER DOCUMENTS (including, Author, Title, Date, Pages, Etc.)

MR	<i>Internetworking with TCP/IP, Volume I, Second Edition, Principles, Protocols, and Architecture, by Douglas E. Comer.; 1991; table of contents, pgs 1-3, 17-19, 311-333</i>

Examiner: <b>MARK H. RINEHART</b> <b>PRIMARY EXAMINER</b>	Date considered 4/8/98
--	------------------------

EXAMINER: Initial if citation considered, whether or not citation is in conformance with MPEP 609; Draw line through citation if not in conformance and not considered. Include copy of this form with next communication to applicant. An \* indicates references that do not require a copy to be provided under 37 C.F.R. §1.98(d) because a copy was previously cited or submitted in a prior application, which is relied upon under 35 U.S.C. §120.

Form PTO-1449 INFORMATION DISCLOSURE STATEMENT	MAIL ROOM AUG 12 1996 PAT. & TRADEMARK OFF.	Docket No.: N0003/7000	Serial No. 08/533,115
	Applicant: Glenn W. Hutton		
	Filed: September 25, 1995		Group: 2305 2756

U.S. Patent Documents

Ex.	Doc. No.	Date	Name	Class	Subcl.	Filed
WR	5 4 5 5 8 5 4	10/3/95	Dilts et al.	—	—	

RECEIVED  
AUG 21 1996  
GROUP 2300

Foreign Patent Documents

Ex.	Doc. No.	Date	Name	Class	Subcl.	Filed

OTHER DOCUMENTS (including, Author, Title, Date, Pages, Etc.)


Examiner: <b>MARK H. RINEHART PRIMARY EXAMINER</b>	Date considered 4/2/98
--	------------------------

EXAMINER: Initial if citation considered, whether or not citation is in conformance with MPEP 609; Draw line through citation if not in conformance and not considered. Include copy of this form with next communication to applicant. An \* indicates references that do not require a copy to be provided under 37 C.F.R. §1.98(d) because a copy was previously cited or submitted in a prior application, which is relied upon under 35 U.S.C. §120.





#4

Form PTO-1449 INFORMATION DISCLOSURE STATEMENT	Docket No.: N0003/7000	Serial No. 08/533,115
	Applicant: Glenn W. Hutton	
	Filed: September 25, 1995	Group: 2305 2756

U.S. Patent Documents

Ex.	Doc. No.	Date	Name	Class	Subcl.	Filed
WR	5 4 3 4 7 9 7	07/1995	Barris			

RECEIVED  
AUG 08 1996  
GROUP 2300

Foreign Patent Documents

Ex.	Doc. No.	Date	Name	Class	Subcl.	Filed

OTHER DOCUMENTS (including, Author, Title, Date, Pages, Etc.)


Examiner: <b>MARK H. RINEHART</b> <b>PRIMARY EXAMINER</b>	Date considered 4/8/98
--	------------------------

EXAMINER: Initial if citation considered, whether or not citation is in conformance with MPEP 609; Draw line through citation if not in conformance and not considered. Include copy of this form with next communication to applicant. An \* indicates references that do not require a copy to be provided under 37 C.F.R. §1.98(d) because a copy was previously cited or submitted in a prior application, which is relied upon under 35 U.S.C. §120.



**UNITED STATES DEPARTMENT OF COMMERCE  
Patent and Trademark Office**

Address: COMMISSIONER OF PATENTS AND TRADEMARKS  
Washington, D.C. 20231

APPLICATION NO.	FILING DATE	FIRST NAMED INVENTOR	ATTORNEY DOCKET NO.
087533,115	09/25/95	HUTTON	649-2

BOOSTEIN & KUDIRKA, PC  
ONE BEACON STREET  
BOSTON MA 02108

LM21/0415

EXAMINER  
RINEHART, M

ART UNIT	PAPER NUMBER
2756	19

DATE MAILED: 04/15/98

**Please find below and/or attached an Office communication concerning this application or proceeding.**

**Commissioner of Patents and Trademarks**



UNITED STATES DEPARTMENT OF COMMERCE  
 Patent and Trademark Office  
 Address: COMMISSIONER OF PATENTS AND TRADEMARKS  
 Washington, D.C. 20231

Paper # 19


In re Application of Glenn W. Hutton :  
 Serial No. 08/533,115 : DECISION ON PETITION  
 Filed: September 25, 1995 : UNDER 37 C.F.R. § 1.48  
 For: POINT-TO-POINT INTERNET PROTOCOL :

This is a decision on the petition filed December 04, 1997 to correct inventorship under 37 C.F.R. § 1.48.

The petition is granted.

The inventorship in this application has been corrected to add Shane D. Mattaway and Craig B. Strickland as joint inventors.

Mark H. Rinehart  
 Primary Examiner  
 Patent Examining Group 2700

  
**MARK H. RINEHART**  
**PRIMARY EXAMINER**

Bookstein & Kudirka, PC  
 One Beacon Street  
 Boston, Massachusetts 02108

**FILE COPY**



ATTORNEY DOCKET NO. N0003/7000

#20  
MDJ  
5-22-98

IN THE UNITED STATES PATENT AND TRADEMARK OFFICE

Applicant: Glenn W. Hutton, et al.  
Serial No.: 08/533,115  
Filed: September 25, 1995  
For: POINT-TO-POINT INTERNET PROTOCOL  
Examiner: Richard J. Gregson, Esq.  
Art Unit: 2302

CERTIFICATE OF MAILING

I hereby certify that the following correspondence is being deposited with the United States Postal Service as first class mail in an envelope addressed to the Assistant Commissioner for Patents, Washington, D.C. 20231 on May 14, 1998.

*Frances M. Cunningham*  
\_\_\_\_\_  
Frances M. Cunningham

Assistant Commissioner for Patents  
Washington, D.C. 20231

Sir:

RESPONSE TO RESTRICTION REQUIREMENT

In response to the Restriction Requirement set forth in Paper No. 18, Applicant hereby elects Group I, directed to claims 1-4, 6-11, 21, 26-64 and 66-67, as set forth in paragraph No. 1 in the Restriction Requirement. The Examiner has invited the Applicant to comment on the different groupings. Applicant has reviewed the groupings and suggests that claims 23 and 24 likewise be categorized with Group I, instead of Group II.

If the Examiner has any questions regarding Applicant's election or suggestion, he is invited to call Applicant's attorney at the number listed below. The Commissioner is hereby authorized to charge any fees under 37 C.F.R. §1.16 and 1.17 that may be required to our Deposit Account No. 20-0065.

Respectfully submitted,

*Bruce D. Jobse*  
\_\_\_\_\_  
Bruce D. Jobse, Reg. No. 33,518  
KUDIRKA & JOBSE, LLP  
One Beacon Street  
Boston, MA 02108  
(617) 367-4600

RECEIVED  
98 MAY 21 AM 11:55  
GROUP 2790



Gp ~~2308~~  
2741

ATTORNEY DOCKET NO. N0003/7000

IN THE UNITED STATES PATENT AND TRADEMARK OFFICE

Applicant: Glenn W. Hutton  
Serial No.: 08/533,115  
Filed: September 25, 1995  
For: POINT-TO-POINT INTERNET PROTOCOL  
Examiner: Richard J. Gregson, Esq.  
Art Unit: 2302

CERTIFICATE OF MAILING

I hereby certify that the following correspondence is being deposited with the United States Postal Service as first class mail in an envelope addressed to the Assistant Commissioner for Patents, Washington, D.C. 20231 on May 14, 1998.

*Frances M. Cunningham*  
Frances M. Cunningham

Assistant Commissioner for Patents  
Washington, D.C. 20231

Sir:

Transmitted herewith for filing in the above-identified patent application is the following paper:

Response to Restriction Requirement

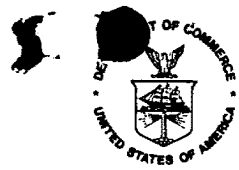
No fee is being submitted. The Commissioner is hereby authorized to charge any fees under 37 C.F.R. §§1.16 and 1.17 that may be required, or credit any overpayment, to our Deposit Account No. 02-3038.

RECEIVED  
98 MAY 21 AM 11:12  
GROUP 2700

Respectfully submitted,

*Bruce D. Jobse*  
Bruce D. Jobse, Reg. No. 33,518  
KUDIRKA & JOBSE, LLP  
One Beacon Street  
Boston, MA 02108  
(617) 367-4600

08/533115



**UNITED STATES DEPARTMENT OF COMMERCE  
Patent and Trademark Office**

Address: COMMISSIONER OF PATENTS AND TRADEMARKS  
Washington, D.C. 20231

APPLICATION NO.	FILING DATE	FIRST NAMED INVENTOR	ATTORNEY DOCKET NO.
087533,115	09/25/95	HUTTON	649-2

BOOSTEIN & KUDIRKA, PC  
ONE BEACON STREET  
BOSTON MA 02108

LM21/0803

<b>EXAMINER</b> RINEHART, M
--------------------------------


<b>ART UNIT</b> 2756	<b>PAPER NUMBER</b> 21
-------------------------	---------------------------

DATE MAILED: 08/03/98

Please find below and/or attached an Office communication concerning this application or proceeding.


Commissioner of Patents and Trademarks

See Attachment

  
**MARK H. RINEHART  
PRIMARY EXAMINER**

**Office Action Summary**

Application No. <b>08/533,115</b>	Applicant(s) <b>Hutton et al.</b>
Examiner <b>Mark H. Rinehart</b>	Group Art Unit <b>2756</b>



- Responsive to communication(s) filed on 5/19/98
- This action is **FINAL**.
- Since this application is in condition for allowance except for formal matters, **prosecution as to the merits is closed** in accordance with the practice under *Ex parte Quayle*, 1935 C.D. 11; 453 O.G. 213.

A shortened statutory period for response to this action is set to expire 30 days month(s), or thirty days, whichever is longer, from the mailing date of this communication. Failure to respond within the period for response will cause the application to become abandoned. (35 U.S.C. § 133). Extensions of time may be obtained under the provisions of 37 CFR 1.136(a).

**Disposition of Claims**

- Claim(s) 1-68 is/are pending in the application.
- Of the above, claim(s) \_\_\_\_\_ is/are withdrawn from consideration.
- Claim(s) \_\_\_\_\_ is/are allowed.
- Claim(s) \_\_\_\_\_ is/are rejected.
- Claim(s) \_\_\_\_\_ is/are objected to.
- Claims 1-68 are subject to restriction or election requirement.

**Application Papers**

- See the attached Notice of Draftsperson's Patent Drawing Review, PTO-948.
- The drawing(s) filed on \_\_\_\_\_ is/are objected to by the Examiner.
- The proposed drawing correction, filed on \_\_\_\_\_ is  approved  disapproved.
- The specification is objected to by the Examiner.
- The oath or declaration is objected to by the Examiner.

**Priority under 35 U.S.C. § 119**

- Acknowledgement is made of a claim for foreign priority under 35 U.S.C. § 119(a)-(d).
  - All  Some\*  None of the CERTIFIED copies of the priority documents have been
    - received.
    - received in Application No. (Series Code/Serial Number) \_\_\_\_\_.
    - received in this national stage application from the International Bureau (PCT Rule 17.2(a)).

\*Certified copies not received: \_\_\_\_\_

- Acknowledgement is made of a claim for domestic priority under 35 U.S.C. § 119(e).

**Attachment(s)**

- Notice of References Cited, PTO-892
- Information Disclosure Statement(s), PTO-1449, Paper No(s). \_\_\_\_\_
- Interview Summary, PTO-413
- Notice of Draftsperson's Patent Drawing Review, PTO-948
- Notice of Informal Patent Application, PTO-152

**FILE COPY** --- SEE OFFICE ACTION ON THE FOLLOWING PAGES ---

Art Unit: 2756

### DETAILED ACTION

1. The previous requirement for restriction is vacated in response to Applicant's suggestion that the claims be grouped differently. A new requirement for restriction is established in the instant Office Action.

#### *Election/Restriction*

2. Restriction to one of the following inventions is required under 35 U.S.C. 121:
- I. Claims 1-4, 6-11, 21, 23-24, 26-64, and 66-67, drawn to a system, apparatus, and method for querying a database server from a first computer to determine the status and identifier associated with a second computer within the operating network for establishing a connection, classified in class 395, subclass 200.58.
  - II. Claims 12-16, 19-20, 22, 25, and 68, drawn to a system, apparatus, and method for directing an electronic mail message from a first computer through a network to a second computer for initiating the second computer to directly message the first computer with its address, classified in class 395, subclass 200.37.
  - III. Claims 17-18, drawn to an apparatus for initiating an electronic mail transmission, classified in class 395, subclass 300.36.
  - IV. Claim 65, drawn to a method for updating and querying a status database server, classified in class 395, subclass 200.54.

3. The inventions are distinct, each from the other because of the following reasons:  
Inventions I, II, III, and IV are related as subcombinations disclosed as usable together in a single

**FILE COPY**



Art Unit: 2756

combination. The subcombinations are distinct from each other if they are shown to be separately usable. In the instant case, invention I has separate utility such as allowing a communicating computer to establish the identifier and online status of a second computer with identifying itself to the second computer to accommodate privacy concerns; invention II has separate utility such as allowing a called computer to determine the sender of a connection request and directly respond or refuse a connection with the calling computer; invention III has separate utility such as preparing a mail message for electronic transmission to a distribution mail server; and invention IV has separate utility such as monitoring status of computers on a network system to enable management of a network system. See MPEP § 806.05(d).

MR 7/21/98  
4. Claim 5<sup>and 25</sup> link(s) inventions I and II. The restriction requirement between the linked inventions is subject to the nonallowance of the linking claim(s), claim 5. Upon the allowance of the linking claim(s), the restriction requirement as to the linked inventions shall be withdrawn and any claim(s) depending from or otherwise including all the limitations of the allowable linking claim(s) will be entitled to examination in the instant application. Applicant(s) are advised that if any such claim(s) depending from or including all the limitations of the allowable linking claim(s) is/are presented in a continuation or divisional application, the claims of the continuation or divisional application may be subject to provisional statutory and/or nonstatutory double patenting rejections over the claims of the instant application. Where a restriction requirement is withdrawn, the provisions of 35 U.S.C. 121 are no longer applicable. *In re Ziegler*, 44 F.2d 1211, 1215, 170 USPQ 129, 131-32 (CCPA 1971). See also MPEP § 804.01.

Art Unit: 2756

5. Because these inventions are distinct for the reasons given above and have acquired a separate status in the art as shown by their different classification, restriction for examination purposes as indicated is proper.

6. Because these inventions are distinct for the reasons given above and the search required for each of Groups I-IV is not required for each of the other Groups, restriction for examination purposes as indicated is proper.

7. Because these inventions are distinct for the reasons given above and have acquired a separate status in the art because of their recognized divergent subject matter, restriction for examination purposes as indicated is proper.

8. Applicant is reminded that upon the cancellation of claims to a non-elected invention, the inventorship must be amended in compliance with 37 CFR 1.48(b) if one or more of the currently named inventors is no longer an inventor of at least one claim remaining in the application. Any amendment of inventorship must be accompanied by a petition under 37 CFR 1.48(b) and by the fee required under 37 CFR 1.17(i).

9. The Examiner notes that although an election was made in the previous requirement for restriction, that the previous requirement has been vacated in order to regroup the invention as suggested by Applicant. Thus, a new election must be made in order to maintain clarity in the record.

Art Unit: 2756


10. Any inquiry concerning this communication or earlier communications from the examiner should be directed to Primary Examiner Rinehart whose telephone number is (703) 305-4815. The examiner can normally be reached on Monday through Thursday from 8:00 AM - 5:30 PM. The examiner can also be reached on alternate Fridays.

If attempts to reach the examiner by telephone are unsuccessful, the examiner's supervisor, Supervisory Primary Examiner Frank J. Asta, can be reached on (703) 305-3817. The fax phone number for the Electrical Examining Technology Center is (703) 308-9051.

Any inquiry of a general nature or relating to the status of this application should be directed to the Group receptionist whose telephone number is (703) 305-3900.

Mark H. Rinehart  
Primary Examiner  
Art Unit 2756



  
**MARK H. RINEHART**  
**PRIMARY EXAMINER**



ATTORNEY DOCKET NO. N0003/7000

#22  
JRM  
8-19-98

IN THE UNITED STATES PATENT AND TRADEMARK OFFICE

Applicant: Glenn W. Hutton, et al.  
Serial No.: 08/533,115  
Filed: September 25, 1995  
For: POINT-TO-POINT INTERNET PROTOCOL  
Examiner: Mark H. Rinehart  
Art Unit: 2302

RECEIVED  
98 AUG 18 AM 9:36  
GROUP 2700

CERTIFICATE OF MAILING

I hereby certify that the following correspondence is being deposited with the United States Postal Service as first class mail in an envelope addressed to the Assistant Commissioner for Patents, Washington, D.C. 20231 on August 11, 1998.

*Frances M. Cunningham*  
Frances M. Cunningham

Assistant Commissioner for Patents  
Washington, D.C. 20231

Sir:

RESPONSE TO RESTRICTION REQUIREMENT

In response to the new Restriction Requirement set forth in Paper No. 21, Applicants hereby elect Group I, directed to claims 1-4, 6-11, 21, 23-24, 26-64 and 66-67, as set forth in paragraph No. 2 of the new Restriction Requirement.

If the Examiner has any questions regarding Applicants' election or suggestion, he is invited to call Applicants' attorney at the number listed below. The Commissioner is hereby authorized to charge any fees under 37 C.F.R. §1.16 and 1.17 that may be required to our Deposit Account No. 02-3038.

Respectfully submitted,

*Bruce D. Jobse*  
Bruce D. Jobse, Reg. No. 33,518  
KUDIRKA & JOBSE, LLP  
Two Center Plaza  
Boston, MA 02108  
(617) 367-4600



GAU 2302  
2783

ATTORNEY DOCKET NO. N0003/7000

IN THE UNITED STATES PATENT AND TRADEMARK OFFICE

Applicant: Glenn W. Hutton  
Serial No.: 08/533,115  
Filed: September 25, 1995  
For: POINT-TO-POINT INTERNET PROTOCOL  
Examiner: Mark H. Rinehart  
Art Unit: 2302

RECEIVED  
98 AUG 18 AM 9:36  
GROUP 2700

CERTIFICATE OF MAILING

I hereby certify that the following correspondence is being deposited with the United States Postal Service as first class mail in an envelope addressed to the Assistant Commissioner for Patents, Washington, D.C. 20231 on August 11, 1998.

*Frances M. Cunningham*  
\_\_\_\_\_  
Frances M. Cunningham

Assistant Commissioner for Patents  
Washington, D.C. 20231

Sir:

Transmitted herewith for filing in the above-identified patent application is the following paper:

Response to Restriction Requirement

No fee is being submitted. The Commissioner is hereby authorized to charge any fees under 37 C.F.R. §§1.16 and 1.17 that may be required, or credit any overpayment, to our Deposit Account No. 02-3038.

Respectfully submitted,

*Bruce D. Jobse*  
\_\_\_\_\_  
Bruce D. Jobse, Reg. No. 33,518  
KUDIRKA & JOBSE, LLP  
Two Center Plaza  
Boston, MA 02108  
(617) 367-4600



#24  
S. 30yd  
11/19/98

ATTORNEY DOCKET NO. N0003/7000

**IN THE UNITED STATES PATENT AND TRADEMARK OFFICE**

Applicant: Glenn W. Hutton  
Serial No.: 08/533,115  
Filed: September 25, 1995  
For: POINT-TO-POINT INTERNET PROTOCOL  
Examiner: Richard J. Gregson, Esq.  
Art Unit: 2302

RECEIVED  
98 NOV -2 AM 7:51  
GROUP 2700

Assistant Commissioner for Patents  
Washington, D.C. 20231

SUPPLEMENTAL RESPONSE

Sir/Madam,

Remarks

Applicant encloses herewith a hard copy signature for the Declaration of Prior Invention under 37 C.F.R. §1.131 originally submitted on December 2, 1997 with a facsimile signature. The original hard copy signature of the declarant was lost. Accordingly, the declarant re-executed the signature page which is enclosed herewith. If the Examiner has any questions regarding this supplemental response or the application in general he is invited to call the Applicant's attorney at the number listed below.

The Commissioner is hereby authorized to charge any other fees under 37 C.F.R. §1.16 and 1.17 that may be required, or credit any overpayment, to our Deposit Account No. 02-3038.

Respectfully submitted,

Bruce D. Jobse, Reg. No. 33,518  
KUDIRKA & JOBSE, LLP  
Two Center Plaza  
Boston, MA 02108  
(617) 367-4600

RECEIVED  
98 AUG 25 PM 1:08  
GROUP 2700

Section 1001 of Title 18 of the United States Code, and that such willful false statements may jeopardize the validity of the application or any patent issued thereon.

  
\_\_\_\_\_  
Glenn W. Hutton

12-2-97.  
Date

Residence: 9725 Hammocks Boulevard, #206  
Miami, Florida 33196

Citizenship: CANADA  
Post Office Address: 9725 Hammocks Boulevard, #206  
Miami, Florida 33196

H:\BDJ\N0003\7000\DLPRINV.WPD

RECEIVED  
98 NOV -2 AM 7:57  
GROUP 2700



ATTORNEY DOCKET NO. N0003/7000

IN THE UNITED STATES PATENT AND TRADEMARK OFFICE

Applicant: Glenn W. Hutton  
Serial No.: 08/533,115  
Filed: September 25, 1995  
For: POINT-TO-POINT INTERNET PROTOCOL  
Examiner: Richard J. Gregson, Esq.  
Art Unit: 2302

CERTIFICATE OF MAILING

I hereby certify that the following correspondence is being deposited with the United States Postal Service as first class mail in an envelope addressed to the Assistant Commissioner for Patents, Washington, D.C. 20231 on August 19, 1998.

*Frances M. Cunningham*  
Frances M. Cunningham

Assistant Commissioner for Patents  
Washington, D.C. 20231

Sir/Madam:

Transmitted herewith for filing is/are the following document(s):

Supplemental Response

If the enclosed papers are considered incomplete, the Mail Room and/or the Application Branch is respectfully requested to contact the undersigned collect at (617) 367-4600, Boston, Massachusetts.

No fee is being submitted. If the fee is insufficient, the balance may be charged to the account of the undersigned, Deposit Account No. 02-3038. A duplicate of this sheet is enclosed.

Respectfully submitted,

*Bruce D. Jobse*  
Bruce D. Jobse, Reg. No. 33,518  
KUDIRKA & JOBSE, LLP  
Two Center Plaza  
Boston, MA 02108  
(617) 367-4600

RECEIVED  
98 NOV -2 AM 7:57  
GROUP 2700

RECEIVED  
98 AUG 25 PM 1:08  
GROUP 2700



GP-2302  
2783



ATTORNEY DOCKET NO. N0003/7000

IN THE UNITED STATES PATENT AND TRADEMARK OFFICE

Applicant: Glenn W. Hutton  
Serial No.: 08/533,115  
Filed: September 25, 1995  
For: POINT-TO-POINT INTERNET PROTOCOL  
Examiner: Richard J. Gregson, Esq.  
Art Unit: 2302

CERTIFICATE OF MAILING

I hereby certify that the following correspondence is being deposited with the United States Postal Service as first class mail in an envelope addressed to the Assistant Commissioner for Patents, Washington, D.C. 20231 on August 19, 1998.

*Frances M. Cunningham*  
Frances M. Cunningham

Assistant Commissioner for Patents  
Washington, D.C. 20231

Sir/Madam:

Transmitted herewith for filing is/are the following document(s):

Supplemental Response

If the enclosed papers are considered incomplete, the Mail Room and/or the Application Branch is respectfully requested to contact the undersigned collect at (617) 367-4600, Boston, Massachusetts.

No fee is being submitted. If the fee is insufficient, the balance may be charged to the account of the undersigned, Deposit Account No. 02-3038. A duplicate of this sheet is enclosed.

Respectfully submitted,

*Bruce D. Jobse*  
Bruce D. Jobse, Reg. No. 33,518  
KUDIRKA & JOBSE, LLP  
Two Center Plaza  
Boston, MA 02108  
(617) 367-4600

RECEIVED  
98 NOV - 2 AM 7:57  
GROUP 2700

RECEIVED  
98 AUG 25 PM 1:08  
GROUP 2700



#25  
S. Zard  
11/19/98

Attorney Docket No. N0003/7000

**IN THE UNITED STATES PATENT AND TRADEMARK OFFICE**

Applicant: Glenn W. Hutton  
Serial No.: 08/533,115  
Examiner: M. Rinehart  
Filed: September 25, 1995  
For: POINT-TO-POINT INTERNET PROTOCOL  
Art Unit: 2756

**CERTIFICATE OF MAILING UNDER 37 C.F.R. §1.8(a)**

The undersigned hereby certifies that this document is being placed in the United States mail with first-class postage attached, addressed to Assistant Commissioner for Patents, Washington, DC 20231 on the 24<sup>th</sup> day of August, 1998

*Frances M. Cunningham*  
\_\_\_\_\_  
Frances M. Cunningham

Assistant Commissioner for Patents  
Washington, DC 20231

Sir/Madam:

**CHANGE OF CORRESPONDENCE ADDRESS**

Pursuant to 37 C.F.R. §1.33(d), we request that the correspondence address for the above-identified patent application be changed to KUDIRKA & JOBSE, LLP, Two Center Plaza, Boston, MA 02108. Please address all future correspondence to the undersigned.

Respectfully submitted,

*Bruce D. Jobse*  
\_\_\_\_\_  
Bruce D. Jobse, Esq.  
Reg. No. 33,518  
KUDIRKA & JOBSE, LLP  
Two Center Plaza  
Boston, MA 02108  
(617) 367-4600

RECEIVED  
98 NOV -2 AM 8:04  
GROUP 2700

RECEIVED  
98 AUG 31 PM 2:36  
GROUP 2700

GP 2756



Attorney Docket No. N0003/7003

IN THE UNITED STATES PATENT AND TRADEMARK OFFICE

Applicant: Glenn W. Hutton  
Serial No.: 08/533,115  
Examiner: M. Rinehart  
Filed: September 25, 1995  
For: POINT-TO-POINT INTERNET PROTOCOL  
Art Unit: 2756

Assistant Commissioner for Patents  
Washington, DC 20231

Sir/Madam:

Transmitted herewith for filing is the following paper:

[X] Change of Correspondence Address

No fee is being submitted. The Commissioner is hereby authorized to charge any fees under 37 C.F.R. §§1.16 and 1.17 that may be required to Deposit Account No. 02-3038

Respectfully submitted,

Bruce D. Jobse, Esq.  
Reg. No. 33,518  
KUDIRKA & JOBSE, LLP  
Two Center Plaza  
Boston, MA 02108  
(617) 367-4600

RECEIVED  
98 AUG 31 PM 2:36  
GROUP 2700

RECEIVED  
98 NOV -2 AM 8:04  
GROUP 2700

=> d his

(FILE 'USPAT' ENTERED AT 08:01:23 ON 26 OCT 1998)

L1 0 S INTERNET/ASN AND TELEPHONE/ASN  
E NETSPEAK/AS  
E NETSPEAK/ASN  
E INTERNET/ASN  
L2 3 S E3  
E NETSCAPE/ASN  
L3 6 S E3  
L4 78 S MICROSOFT/ASN AND INTERNET  
L5 87 S L1-L4  
E HUTTON, GLENN/IN  
L6 1 S E4  
E MATLAWAY/IN  
E STRICKLAND, CRAIG/IN  
L7 193 S (INTERNET OR TCPIP) (5A) TELEPHON?  
L8 54976 S 395/200.3-200.83/CCLST OR 370/CLAS OR 379/CLAS  
L9 66 S L7 AND L8  
=>



**UNITED STATES DEPARTMENT OF COMMERCE  
Patent and Trademark Office**

Address: COMMISSIONER OF PATENTS AND TRADEMARKS  
Washington, D.C. 20231

*PS*

APPLICATION NO.	FILING DATE	FIRST NAMED INVENTOR	ATTORNEY DOCKET NO.
08/533,115	09/25/95	HUTTON	G 649-2

LM02/1028

BOOSTEIN & KUDIRKA, PC  
ONE BEACON STREET  
BOSTON MA 02108

EXAMINER

RINEHART, M

ART UNIT	PAPER NUMBER
2756	<i>23</i>

DATE MAILED:

10/28/98

Please find below and/or attached an Office communication concerning this application or proceeding.


Commissioner of Patents and Trademarks

*See Attachment*

Mark H. Rinehart  
Primary Examiner

**Office Action Summary**

Application No. <b>08/533,115</b>	Applicant(s) <b>Hutton et al.</b>
Examiner <b>Mark H. Rinehart</b>	Group Art Unit <b>2756</b>



Responsive to communication(s) filed on 12/4/97 and 8/14/98

This action is **FINAL**.

Since this application is in condition for allowance except for formal matters, prosecution as to the merits is closed in accordance with the practice under *Ex parte Quayle*, 1935 C.D. 11; 453 O.G. 213.

A shortened statutory period for response to this action is set to expire three (3) month(s), or thirty days, whichever is longer, from the mailing date of this communication. Failure to respond within the period for response will cause the application to become abandoned. (35 U.S.C. § 133). Extensions of time may be obtained under the provisions of 37 CFR 1.136(a).

**Disposition of Claims**

Claim(s) 1-68 is/are pending in the application.

Of the above, claim(s) 5, 12-20, 22, 25, 65, and 68 is/are withdrawn from consideration.

Claim(s) \_\_\_\_\_ is/are allowed.

Claim(s) 1-4, 6-11, 21, 23, 24, 26-64, 66, and 67 is/are rejected.

Claim(s) \_\_\_\_\_ is/are objected to.

Claims 5, 12-20, 22, 25, 65, and 68 are subject to restriction or election requirement.

**Application Papers**

See the attached Notice of Draftsperson's Patent Drawing Review, PTO-948.

The drawing(s) filed on \_\_\_\_\_ is/are objected to by the Examiner.

The proposed drawing correction, filed on \_\_\_\_\_ is  approved  disapproved.

The specification is objected to by the Examiner.

The oath or declaration is objected to by the Examiner.

**Priority under 35 U.S.C. § 119**

Acknowledgement is made of a claim for foreign priority under 35 U.S.C. § 119(a)-(d).

All  Some\*  None of the CERTIFIED copies of the priority documents have been  
 received.

received in Application No. (Series Code/Serial Number) \_\_\_\_\_.

received in this national stage application from the International Bureau (PCT Rule 17.2(a)).

\*Certified copies not received: \_\_\_\_\_

Acknowledgement is made of a claim for domestic priority under 35 U.S.C. § 119(e).

**Attachment(s)**

Notice of References Cited, PTO-892

Information Disclosure Statement(s), PTO-1449, Paper No(s). \_\_\_\_\_

Interview Summary, PTO-413

Notice of Draftsperson's Patent Drawing Review, PTO-948

Notice of Informal Patent Application, PTO-152

--- SEE OFFICE ACTION ON THE FOLLOWING PAGES ---

**FILE COPY**

**Part III DETAILED ACTION**

1. This application has been examined. Claims 1-68 are pending.
2. The amendment received on 12/04/97 has been entered. New claims 54-68 have been added.
3. The declaration filed on 12/04/97 under 37 CFR 1.131 is sufficient to overcome the Civanlar et al. (US 5,581,552) reference.

***Election/Restriction***

4. Applicant's election without traverse of Invention Group I consisting of claims 1-4, 6-11, 21, 23-24, 26-64, and 66-67 in Paper No. 22 received 08/14/98 is acknowledged.
5. Claims 5, 12-20, 22, 25, 65, and 68 are withdrawn from further consideration by the examiner, 37 CFR 1.142(b) as being drawn to non-elected Inventions Groups II, III, and IV. Election was made **without** traverse in Paper No. 22.

***Information Disclosure Statement***

6. In view of the extremely large number of references submitted by the Applicant(s) for consideration of this application, the Applicant(s) are requested to identify any references which have particular significance in the prosecution of this application for further consideration by the Examiner. Applicant(s) should also indicate the specific features, corresponding passages, and figures of such references which are believed to be germane to the invention claimed in the application. Applicant is reminded that mere presentation of a reference does not preclude presentation of an analysis of the reference to insure proper consideration during examination.

**FILE COPY**

***Specification***

7. The lengthy specification has not been checked to the extent necessary to determine the presence of all possible minor errors. Applicant's cooperation is requested in correcting any errors of which applicant may become aware in the specification.

***Claim Rejections - 35 USC § 102***

8. The following is a quotation of the appropriate paragraphs of 35 U.S.C. 102 that form the basis for the rejections under this section made in this Office action:

A person shall be entitled to a patent unless --

(e) the invention was described in a patent granted on an application for patent by another filed in the United States before the invention thereof by the applicant for patent, or on an international application by another who has fulfilled the requirements of paragraphs (1), (2), and (4) of section 371(c) of this title before the invention thereof by the applicant for patent.

9. Claims 1-4 are rejected under 35 U.S.C. 102(e) as being clearly anticipated by Gordon (US 5,608,786).

Gordon teaches a system operating to establish a point-to-point connection through an internet system utilizing IP addressing and telephone connection setup based on active status response to queries of a connection database. See Abstract; Figures 1 and 5; and col. 1-3, 4-6, and 8-10. Thus, Gordon reads on the claimed method.

***Claim Rejections - 35 USC § 103***

10. The following is a quotation of 35 U.S.C. § 103 which forms the basis for all obviousness rejections set forth in this Office action:

A patent may not be obtained though the invention is not identically disclosed or described as set forth in section 102 of this title, if the differences between the subject matter sought to be patented and the prior art are such that the subject matter as a whole would have been obvious at the time the invention was made to a person having ordinary skill in the art to which said subject matter pertains. Patentability shall not be negated by the manner in which the invention was made.



Subject matter developed by another person, which qualifies as prior art only under subsection (f) or (g) of section 102 of this title, shall not preclude patentability under this section where the subject matter and the claimed invention were, at the time the invention was made, owned by the same person or subject to an obligation of assignment to the same person.

11. Claims 1-4 are rejected under 35 U.S.C. § 103 as being unpatentable over Cohn, et al, (US 5,740,231) in view of Morgan, et al., (US 5,524,254).

The claimed invention found within Claim 1 consists of a method for establishing point-to-point Internet communications comprising (a) storing in a database a set of IP addresses for on-line nodes, (b) transmitting a query from a node to a server to determine the status of a second node, and © retrieving the IP address of the second node from the database in to establish communication between the two nodes. Cohn, et al., at Figures 6 and 13 and col. 15, lns. 20-63 and col. 23, ln. 29 - col. 24, ln. 42, teaches a multimedia server which uses a communication protocol in which the requesting node sends a request for communication with another node through a address server, which contains an address database, to obtain the address and routing information necessary to complete the communication. Cohn, et al., doesn't specify searching the database to match the address with the destination node. Morgan, et al, in columns in columns 3-4, teaches the look-up procedure into the database which is performed to retrieve the matching address from the database for use in initiating communications over an network. It would have been obvious to one of ordinary in the art at the time the claimed invention was made to include an database and search/retrieval mechanism to locate the needed network address because such a mechanism permits the database to me modified over time to allow dynamic address assignment thus reducing the need to larger address identifiers and thus the amount of data that needs to be transmitted with each packet of data.

Regarding Claim 2, the claimed invention adds the further limitation to the invention found within Claim 1 that steps of obtaining the on-line status and IP address of the second node

include the steps of: (b1) sending a query to a server, (c1) searching the server's database, (c2) determining the on-line status of the second node, (c3) retrieving the IP address of the second node, (c4) and transmitting the IP address of the second node from the server to the requesting node. As was discussed above regarding Claim 1, Morgan, et al., in columns 3-4, teaches the look-up procedure into the database which is performed to retrieve the matching address from the database for use in initiating communications over an network. It would have been obvious to one of ordinary in the art at the time the claimed invention was made to include an database and search/retrieval mechanism to locate the needed network address because such a mechanism permits the database to be modified over time to allow dynamic address assignment thus reducing the need to larger address identifiers and thus the amount of data that needs to be transmitted with each packet of data.

Regarding Claim 3 and 4, the claimed invention in Claim 3 adds the further limitation to the invention found within Claim 2 that the claimed process generate and transmit an error message which is sent to the requesting node when the second node's status is off-line. The claimed invention Claim 4 adds the further limitation to the invention found within Claim 1 that secondary communications protocol is used when a off-line status is found. Morgan, et al., in columns 13-14 teaches the process of handling error condition where the requested second node is not available, that the processing terminates gracefully. Implicit within this operation is the transmittal of appropriate messages to the requesting node of this condition with the initiation of error recovery procedures..

12. Claim 6, which teaches an apparatus claim, fail to teach or define above or beyond Claims 1-4 above and are rejected for the same reasons set forth above in the rejections of Claims 1-4, supra.

13. Claims 7-11, which also teaches a set of apparatus claims, fail to teach or define above

or beyond Claims 1-4 above and are rejected for the same reasons set forth above in the rejections of Claims 1-4, supra.

14. Claim 21, which teaches a computer program product claim, fail to teach or define above or beyond Claims 1-4 above and are rejected for the same reasons set forth above in the rejections of Claims 1-4, supra.

15. Claims 23-24, which also teaches a set of apparatus claims, fail to teach or define above or beyond Claims 1-4 above and are rejected for the same reasons set forth above in the rejections of Claims 1-4, supra.

16. Claims 26-42, 54-59, and 67, which teaches a set of method claims, fail to teach or define above or beyond the apparatus found within Claims 1-4 above and are rejected for the same reasons set forth above in the rejections of Claims 1-4, supra.

17. Claims 43-53, 60-64, and 66, which teach a set of computer program product claims, fail to teach or define above or beyond the apparatus found within Claims 1-4 above and are rejected for the same reasons set forth above in the rejections of Claims 1-4, supra.

18. Claims 5 and 25 are rejected under 35 U.S.C. 103 as being unpatentable over Cohn, et al, (US 5,740,231) in view of Morgan, et al., (US 5,524,254) as applied to claims 1-4 above, and further in view of December, et al. (The World Wide Web Unleashed) . The claimed invention in Claims 5 and 25 adds the further limitation to the invention found within Claim 4 that performing the secondary communication protocol includes (d1) transmitting an e-mail signal over Internet from the first node with its IP address, (d2) transmitting the message thru the Internet for delivery at the second node, and (d3) transmitting a second IP address to the first node for establishing the point-to-point communications. The combination of Cohn, et al., and Morgan, et al. teaches the communications mechanism claimed here in utilizing the address server and its database to initiate communications between the two nodes. Neither of these two references teaches the

message transport mechanism which is utilized to transmit the various messages between the various processors on the network. December, et al., on pages 6-9 teaches the various message and data types which are readily transported between two nodes attached to the Internet and that each type of message is a format for which blocks of data are sent between different processors. It would have been obvious to one of ordinary skill in the art at the time the claimed invention was made to utilize Internet e-mail messages as the means to transport various requests between two processors attached to the Internet because it is a well defined and well supported data transport means for moving data between processors across the Internet and that the substitution of e-mail as the transport mechanism for any other message transport means would be within the ordinary skill of the art as these transport means are equivalent means for moving blocks of data between nodes of the network.

#### ***Response to Arguments***

19. Applicant's arguments with respect to the claims have been considered but are moot in view of the new ground(s) of rejection.

#### ***Conclusion***

20. The prior art made of record and not relied upon is considered pertinent to applicant's disclosure:

Heylighen teaches the basics of Internet communication and the addressing means used therein.

21. **Any response to this action should be mailed to:**

Commissioner of Patents and Trademarks  
Washington, D.C. 20231

**or faxed to:**

(703) 308-9051, (for formal communications intended for entry)

Or:

(703) 308-5358, (for informal or draft communications, please label  
"PROPOSED" or "DRAFT")

Hand-delivered responses should be brought to Crystal Park II, 2121 Crystal  
Drive, Arlington, VA., Sixth Floor (Receptionist).

22. Any inquiry concerning this communication or earlier communications from the examiner should be directed to Primary Examiner Rinehart whose telephone number is (703) 305-4815. The examiner can normally be reached on Monday through Thursday from 8:00 AM - 5:30 PM. The examiner can also be reached on alternate Fridays.

If attempts to reach the examiner by telephone are unsuccessful, the examiner's supervisor, Supervisory Primary Examiner Frank J. Asta, can be reached on (703) 305-3817. The fax phone number for the Electrical Examining Technology Center is (703) 308-9051.

Any inquiry of a general nature or relating to the status of this application should be directed to the Group receptionist whose telephone number is (703) 305-3900.

Mark H. Rinehart  
Primary Examiner  
Art Unit 2756



A handwritten signature in black ink, appearing to read "Mark H. Rinehart".

**Mark H. Rinehart**  
**Primary Examiner**

**Notice of References Cited**

Application No. <b>08/533,115</b>	Applicant(s) <b>Hutton et al.</b>	
Examiner <b>Mark H. Rinehart</b>	Group Art Unit <b>2756</b>	Page 1 of 1

**U.S. PATENT DOCUMENTS**

	DOCUMENT NO.	DATE	NAME	CLASS	SUBCLASS
A	5,608,786	3/4/97	Gordon	----	----
B	5,740,231	4/14/98	Cohn et al.	----	----
C					
D					
E					
F					
G					
H					
I					
J					
K					
L					
M					

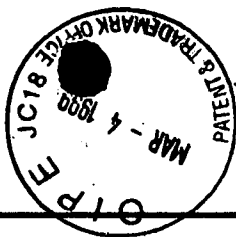
**FOREIGN PATENT DOCUMENTS**

	DOCUMENT NO.	DATE	COUNTRY	NAME	CLASS	SUBCLASS
N						
O						
P						
Q						
R						
S						
T						

**NON-PATENT DOCUMENTS**

	DOCUMENT (Including Author, Title, Source, and Pertinent Pages)	DATE
U		
V		
W		
X		

**FILE COPY**



#26  
D. Sand  
3/16/99

<b>INFORMATION DISCLOSURE TRANSMITTAL</b>		Docket No.: N0003/7000
Applicant:	Glenn W. Hutton, et al.	<b>RECEIVED</b> <b>MAR 10 1999</b> <b>Group 2700</b>
Serial No	08/533,115	
Filed:	September 25, 1995	
For:	METHOD AND APPARATUS FOR ESTABLISHING POINT-TO-POINT COMMUNICATIONS OVER A COMPUTER NETWORK	
Examiner:	M. Rinehart	
Art Unit:	2756	

CERTIFICATE OF MAILING UNDER 37 C.F.R. §1.8(a)

The undersigned hereby certifies that this document is being placed in the United States mail with first-class postage attached, addressed to Assistant Commissioner for Patents, Washington, DC 20231 on March 1, 1999.

*Frances M. Cunningham*  
Frances M. Cunningham

Assistant Commissioner for Patents  
Washington, DC 20231

In keeping with the duty of candor and good faith owed to the Patent and Trademark Office, Applicant wishes to bring information to the attention of the Examiner. The filing of this statement shall not be construed as a representation that a search has been made or as an admission that this information is, or is considered to be, material to patentability as defined in 37 C.F.R. §1.56(b).

**Enclosures**

- A form PTO-1449 listing this information is attached.
- A copy of each document cited is enclosed.
- Copies of documents cited are not enclosed because
- A petition requesting consideration of the information disclosure statement is attached (see below.)

**Fees**

- This statement is filed before the later of (1) three months of (i) the filing of a national application or (ii) the entry date for the national stage of an international application and (2) the mailing date of a first office action on the merits. No fee is due.

Void date: 03/08/1999 SLUANG  
03/08/1999 SLUANG 00000101 08533115  
03 FC:998

This statement is filed before the mailing date of either a final office action or a notice of allowance, and

- The submission fee of \$240.00 under 37 CFR §1.17(p) is enclosed, or
- A petition requesting consideration of the information disclosure statement is attached, the petition fee of \_\_\_\_\_ under 37 CFR §1.17(i) is enclosed, and
- each item of information contained in this statement was cited in a communication from a foreign patent office in a counterpart

03/08/1999 SLUANG 00000101 08533115  
240.00 DP  
10.00 DP  
02 FC:126  
03 FC:998

Information Disclosure Transmittal 1

- foreign application not more than three months prior to the filing of this statement, or
- no item of information contained in this statement was cited in a communication from a foreign patent office in a counterpart foreign application and, to the knowledge of the person signing the statement after making reasonable inquiry, no item of information contained in this statement was known to any individual designated in 37 CFR §1.56(c) more than three months prior to the filing of this statement.

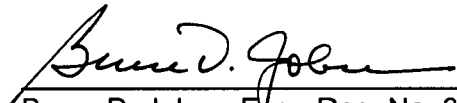
**Payment**

- A check in the amount of the submission or petition fee is enclosed.
- Charge Account No. 02-3038 in the amount of the submission or petition fee. A duplicate of this transmittal sheet is attached.

**Authorization to Charge Additional Fees**

- The Commissioner is hereby authorized to charge any additional fees under 37 C.F.R. §1.16 and §1.17 required by the attached paper and during the entire pendency of this application to Account No. 02-3038.

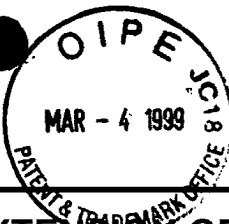
Respectfully submitted,



Date: 3/1/99

Bruce D. Jobse, Esq. Reg. No. 33,518  
KUDIRKA & JOBSE, LLP  
Customer Number 021127  
Tel: (617) 367-4600 Fax: (617) 367-4656





#29  
D. Sand  
3/11/99

<b>PETITION FOR EXTENSION OF TIME</b>		Docket No. N0003/7000
Applicant:	Glenn W. Hutton, et al.	
Serial No.	08/533,115	
Filed:	September 25, 1995	
For:	METHOD AND APPARATUS FOR ESTABLISHING POINT-TO-POINT COMMUNICATIONS OVER A COMPUTER NETWORK	
Examiner:	M. Rinehart	<b>RECEIVED</b> MAR 10 1999
Art Unit:	2756	

Group 2700

CERTIFICATE OF MAILING UNDER 37 C.F.R. §1.8(a)

The undersigned hereby certifies that this document is being placed in the United States mail with first-class postage attached, addressed to Assistant Commissioner for Patents, Washington, DC 20231 on March 1, 1999.

*Frances M. Cunningham*  
Frances M. Cunningham

Assistant Commissioner for Patents  
Washington, D.C. 20231

This is a request under the provisions of 37 C.F.R. §1.136(a) to extend the period for filing a response in the above-identified application up to, and including, March 1, 1999.

Small Entity

- A small entity statement under 37 C.F.R. §1.27 has already been filed.
- A small entity statement under 37 C.F.R. §1.27 is attached

Extension

The requested extension and the appropriate fee are as follows:

- One month (37 C.F.R. §1.17(a)(1)) \$110.00
- Two months (37 C.F.R. §1.17(a)(2))
- Three months (37 C.F.R. §1.17(a)(3))
- Four months (37 C.F.R. §1.17(a)(4))
- Five months (37 C.F.R. §1.17(a)(5))

Reduction by one-half for request by small entity  
**Total Fee: \$110.00**

Payment

- A check in the amount of the extension fee is enclosed.
- The extension fee is included in a fee payment made in connection with papers accompanying this petition.

03/08/1999 SLUANG 00000101 08533115  
01 FC:115 110.00 OP

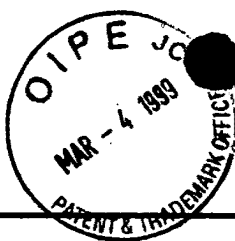
Rep In. Ref: 03/08/1999 SLUANG 0012495700  
DAH: 023038 Name/Number: 08533115 \$10.00 CR  
FC: 704

- Charge the extension fee to deposit account no. 02-3038. A duplicate of this sheet is attached.  
 The Commissioner is hereby authorized to charge any other fees under 37 C.F.R. §1.16 and §1.17 that may be required, or credit any overpayment, to deposit account no. 02-3038.

*Bruce D. Jobse*

Date: March 1, 1989

Bruce D. Jobse, Esq. Reg. No. 33,518  
KUDIRKA & JOBSE, LLP  
Customer Number 021127  
Tel: (617) 367-4600 Fax: (617) 367-4656



#28C  
S. Zord  
3/16/99

<b>AMENDMENT</b>		Docket No. N0003/7000
Applicant:	Glenn W. Hutton, et al.	
Serial No.	08/533,115	
Filed:	September 25, 1995	
For:	METHOD AND APPARATUS FOR ESTABLISHING POINT-TO-POINT COMMUNICATIONS OVER A COMPUTER NETWORK	
Examiner:	M. Rinehart	
Art Unit:	2756	

CERTIFICATE OF MAILING UNDER 37 C.F.R. §1.8(a)

The undersigned hereby certifies that this document is being placed in the United States mail with first-class postage attached, addressed to Assistant Commissioner for Patents, Box Non-Fee Amendment, Washington, DC 20231 on March 1, 1999.

*Frances M. Cunningham*  
Frances M. Cunningham

Assistant Commissioner for Patents  
Washington, D.C. 20231

**In response to the office communication dated October 28, 1998, please amend the above-identified application as follows:**

**In the Specification:**

- Page 2, line 13, change "XXX.XXX.XXX.XXX" to --XXX.XXX.XXX--;
- line 14, change "XXX.XXX.XXX.XXX.10" to --XXX.XXX.XXX.10--;
- line 15, change "XXX.XXX.XXX.XXX.11" to --XXX.XXX.XXX.11--;
- line 15, change "XXX.XXX.XXX.XXX.12" to --XXX.XXX.XXX.12--;
- Page 11, line 10, change "2<sup>32</sup>" to --32-bit--.

**In the claims:**

- Please amend the claims as follows:
- Please cancel claims 1-4 and 6-11, without prejudice.

21. (Amended) A computer program product for use with a computer system, the computer system executing a first process and operatively connectable to a

C 32

second process [having first and second processors] and a server [operatively coupled] over a computer network, the computer program product comprising:

a computer usable medium having program code [means] embodied in the medium [for establishing a point-to-point communications link between the first processor and the second processor over the computer network], the [medium further] program code comprising:

program code for transmitting to the server a network protocol address received by the first process following connection to the computer network;

program code [means] for transmitting, [from the first processor] to the server, a query as to whether the second [processor] process is connected to the computer network;

program code [means] for receiving a network protocol address of the second [processor] process from the server, when the second [processor] process is connected to the computer network; and

program code [means], responsive to the network protocol address of the second [processor] process, for establishing a point-to-point communication link between the first [processor] process and the second [processor] process over the computer network.

---

23. (Amended) [A computer server] An apparatus for enabling point-to-point communications between a first and a second [processor] process over a computer network, the [server] apparatus comprising:

a [server] processor;

a network interface [means], operatively coupled to the [server] processor, for connecting the [server] apparatus to the computer network;

a memory, operatively coupled to the processor, for storing a network protocol address for selected of a plurality of [processors connected] processes, each network protocol address stored in the memory following connection of a respective process to the computer network;

means, responsive to a query from the first [processor] process, for determining the on-line status of the second [processor] process and for

33

transmitting [the] a network protocol address of the second [processor] process to the first [processor] process in response to a positive determination of the on-line status of the second [processor] process.

3  
24. (Amended) The computer server apparatus of claim ~~23~~<sup>2</sup> further comprising a timer [means], operatively coupled to the [server] processor, for time stamping the network protocol addresses stored in the memory.

4  
26. (Amended) [In a connection server having a database and a computer network operatively coupled thereto, a] A method for enabling point-to-point communication between a first [processing unit] process and a second [processing unit] process over a computer network, the method comprising the steps of:

- A. receiving and storing into a computer memory [storing in the database,] a respective network protocol address for [each] selected of a plurality of [processing units] processes that have an on-line status with respect to the computer network, each of the network protocol addresses received following connection of the respective process to the computer network;
- B. receiving a query from the first [processing unit] process to determine the on-line status of the second [processing unit] process;
- C. determining the on-line status of the second [processing unit] process; and
- D. transmitting an indication of the on-line status of the second [processing unit] process to the first [processing unit] process over the computer network.

5  
27. (Amended) The method of claim ~~26~~<sup>4</sup> wherein step C further comprises the steps of:

34

c.1 searching the [database] computer memory for an entry relating the second [processing unit] process; and

c.2 retrieving [the] a network protocol address of the second [processing unit] process in response to a positive determination of the on-line status of the second [processing unit] process.

4  
28. (Amended) The method of claim ~~26~~<sup>4</sup> wherein step D further comprises the steps of:

d.1 transmitting the network protocol address of the second [processing unit] process to the first [processing unit] process when the second [processing unit] process is determined in step C to have a positive on-line status with respect to the computer network.

7  
~~29~~. (Amended) The method of claim ~~26~~<sup>4</sup> wherein step D further comprises the steps of:

d.1 generating an off-line message when the second [processing unit] process is determined in step C to have a negative on-line status with respect to the computer network; and

d.2 transmitting the off-line message to the first [processing unit] process.

8  
30. (Amended) The method of claim ~~26~~<sup>4</sup> further comprising the steps of:

E. receiving an E-mail signal comprising a first network protocol address from the first [processing unit] process; and

F. transmitting the E-mail signal over the computer network to the second [processing unit] process.

9  
31. (Amended) The method of claim ~~30~~<sup>8</sup> wherein the E-mail signal further comprises a session number and wherein step F further comprises the step of:

f.1 transmitting the session number and network protocol address over the computer network to the second [processor] process.

4-  
35

10

~~32.~~ (Amended) In a computer system, a [A] method for establishing a point-to-point communication link from a caller [processor] process to a callee [processor] process over a computer network, the caller [processor having] process having a user interface and being operatively [coupled] connectable to the callee [processor] process and a server over the computer network, the method comprising the steps of:

C3

A. [generating an] providing a user interface element representing a first communication line;

B. [generating an] providing a user interface element representing a first callee [processor] process; and

C. establishing a point-to-point communication link from the caller [processor] process to the first callee [processor] process, in response to a user associating the element representing the first callee [processor] process with the element representing the first communication line.

11

10

~~33.~~ (Amended) The method of claim ~~32~~ wherein step C further comprises the steps of:

c.1 querying the server as to the on-line status of the first callee [processor] process and

c.2 receiving a network protocol address of the first callee [processor] process over the computer network from the server.

E

12

10

~~34.~~ (Amended) The method of claim ~~32~~ further comprising the step of:

D. [generating] providing an element representing a second communication line.

13

12

~~35.~~ (Amended) The method of claim ~~34~~ further comprising the step<sup>s</sup> of:

E. terminating the point-to-point communication link from the caller [processor] process to the first callee [processor] process, in response to the

E

5-  
36

user disassociating the element representing the first callee [processor] process from the element representing the first communication line; and

F. establishing a different point-to-point communication link from the caller [processor] process to the first callee [processor] process, in response to the user associating the element representing the first callee [processor] process with the element representing the second communication line.

14  
~~36.~~

10

(Amended) The method of claim ~~32~~ further comprising the steps of:

D. [generating an] providing a user interface element representing a second callee [processor] process; and

E. establishing a conference point-to-point communication link between the caller [processor] process and the first and second callee [processors] process, in response to the user associating the element representing the second callee [processor] process with the element representing the first communication line.

15  
~~37.~~

10

(Amended) The method of claim ~~32~~ further comprising the step of:

F. removing the second callee [processor] process from the conference point-to-point communication link in response to the user disassociating the element representing the second callee [processor] process from the element representing the first communication line.

16  
~~38.~~

10

(Amended) The method of claim ~~32~~ further comprising the steps of:

D. [generating an] providing a user interface element representing a communication line having a temporarily disabled status; and

E. temporarily disabling a point-to-point communication link between the caller [processor] process and the first callee [processor] process, in response to the user associating the element representing the first callee [processor] process with the element representing the communication line having a temporarily disabled status.

-6-  
37



17  
~~39~~. (Amended) The method of claim ~~38~~<sup>16</sup> wherein the element [generated] provided in step D represents a communication line on hold status.

C3  
~~40~~. (Amended) The method of claim ~~39~~<sup>17</sup> wherein the element [generated] provided in step D represents a communication line on mute status.

~~41~~. (Amended) The method of claim ~~32~~<sup>10</sup> wherein the caller [processor] process further comprises a visual display and the user interface comprises a graphic user interface.

C4  
~~42~~. (Amended) The method of claim ~~41~~<sup>19</sup> wherein the steps of establishing a point-to-point link as described in step C is performed in response to [a user manipulating] manipulation of the graphic elements on the graphic user interface.

C5  
~~43~~. (Amended) A computer program product for use with a computer system comprising:  
a computer usable medium having program code [means] embodied in the medium for establishing a point-to-point communication link from a caller [processor] process to a callee [processor] process over a computer network, the caller [processor] process having a user interface and being operatively [coupled] connectable to the callee [processor] process and a server over the computer network, the medium further comprising:

program code [means] for generating an element representing a first communication line;

program code [means] for generating an element representing a first callee [processor] process;

program code [means], responsive to a user associating the element representing the first callee [processor] process with the element representing the first communication line, for establishing a point-to-point communication link from the caller [processor] process to the first callee [processor] process.

38

22

21

44. (Amended) The computer program product of claim ~~43~~ wherein the program code [means] for establishing a point-to-point communication link further comprises:

program code [means] for querying the server as to the on-line status of the first callee [processor] process; and

program code [means] for receiving a network protocol address of the first callee [processor] process over the computer network from the server.

C

23

21

45. (Amended) A computer program product of claim ~~43~~ further comprising: program code [means] for generating an element representing a second communication line.

24

23

46. (Amended) The computer program product of claim ~~45~~ further comprising: program code [means], responsive to the user disassociating the element representing the first callee [processor] process from the element representing the first communication line, for terminating the point-to-point communication link from the caller [processor] process to the first callee [processor] process; and program code [means], responsive to the user associating the element representing the first callee [processor] process with the element presenting the second communication line, for establishing a different point-to-point communication link from the caller [processor] process to the first callee [processor] process.

25

21

47. (Amended) The computer program product of claim ~~43~~ further comprising: program code [means] for generating an element representing a second callee [processor] process; and

program code means, responsive to the user associating the element representing the second callee [processor] process with the element representing the first communication line, for establishing a conference communication link between the caller [processor] process and the first and second callee [processors] process.

39

24  
48. (Amended) The computer program product of claim 47<sup>25</sup> further comprising:  
program code [means], responsive to the user disassociating the element  
representing the second callee [processor] process from the element  
representing the first communication line, for removing the second callee  
[processor] process from the conference communication link.

CS  
27  
49. (Amended) The computer program product of claim 43<sup>21</sup> further comprising:  
program code [means] for generating an element representing a  
communication line having a temporarily disabled status; and  
program code [means], responsive [to user associating] association of the  
element representing the first callee [processor] process with the element  
representing the communication line having a temporarily disabled status, for  
temporarily disabling the point-to-point communication link between the caller  
[processor] process and the first callee [processor] process.

28  
50. The computer program product of claim 49<sup>27</sup> wherein the communication  
line having a temporarily disabled status comprises a communication line on hold  
status.

29  
51. The computer program product of claim 49<sup>27</sup> wherein the communication  
line having a temporarily disabled status comprises a communication line on  
mute status.

30  
52. (Amended) A computer program product of claim 43<sup>21</sup> wherein the  
computer system [caller processor] further comprises a visual display and the  
user interface comprises a graphic user interface.

31  
53. (Amended) The computer program product of claim 52<sup>30</sup> wherein the  
element representing the first communication line and the element representing  
the first callee [processor] process are graphic elements and wherein the

program code [means] for establishing a point-to-point communication link from the caller [processor] process to the first callee [processor] process further comprises:

32  
program code [means], responsive to [a user manipulating] manipulation of the graphic elements on the graphic user interface, for establishing the point-to-point communication link from the caller [processor] process to the first callee [processor] process.

32  
34. (Amended) A method of locating a [user] process over a computer network comprising the steps of :

30  
a. maintaining an Internet accessible list having a plurality of selected entries, each entry comprising an [electronic mail address] identifier and a corresponding Internet protocol address [for] of a process currently connected to the Internet, the Internet Protocol address added to the list following connection of the process to the computer network; and

b. in response to identification of one of the list entries by a requesting process, providing one of the [electronic mail address] identifier and the corresponding Internet protocol address of the identified entry to the requesting process.

33  
55. (Amended) A method for locating [users] processes having dynamically assigned network protocol addresses over a computer network, the method comprising the steps of:

a. maintaining, in a computer memory, a network accessible compilation of entries, [each entry] selected of the entries comprising a network protocol address and a corresponding identifier [for a user] of a process connected to the computer network[;], the network protocol address of the corresponding process assigned to the process upon connection to the computer network; and

41

b. in response to identification of one of the entries by a requesting process providing one of the identifier and the network protocol address to the requesting process.

34

56. (Amended) The method of claim 55 further comprising the step of:

33

c. modifying the compilation of entries.

35

57. (Amended) The method of claim 56 wherein step c further comprises:

34

c.1 adding an entry to the compilation upon the occurrence of a predetermined event.

36

58. (Amended) The method of claim 57 wherein the predetermined event comprises notification by a user process of an assigned network protocol address.

35

37

59. (Amended) The method of claim 56 wherein step c further comprises:

34

c.1 deleting an entry from the compilation upon the occurrence of a predetermined event.

38

60. (Amended) A computer program product for use with a [server apparatus] computer system having a memory and being operatively [coupled] connectable over a computer network to one or more computer processes, the computer program product comprising a computer usable medium having program code embodied in the medium the program code comprising:

a. program code configured to maintain, in [a] the computer memory, a network accessible compilation of entries, [each entry] selected of the entries comprising a network protocol address and a corresponding identifier [for] of a process connected to the computer network, the network protocol address of the corresponding process assigned to the process upon connection to the computer network; and

b. program code responsive to identification of one of the entries by a requesting process and configured to provide one of the identifier and the network protocol address to the requesting process.

39  
61. (Amended) The computer program product of claim ~~60~~<sup>38</sup> further comprising:  
c. program code configured to modify the compilation of entries.

C 40  
62. (Amended) The computer program product of claim ~~61~~<sup>39</sup> wherein program code configured to modify comprises:

c.1 program code configured to add an entry to the compilation upon the occurrence of a predetermined event.

41  
63. (Amended) The computer program product of claim ~~62~~<sup>40</sup> wherein the predetermined event comprises notification by a process of an assigned network protocol address.

42  
64. (Amended) The computer program product of claim ~~60~~<sup>38</sup> wherein step c further comprises:

c.1 program code configured to delete an entry from the compilation upon the occurrence of a predetermined event.

---

C 43  
65. (Amended) A computer program product for use with a computer system, the computer system [including] executing a first process operatively coupled over a computer network to a second process and a server process, the computer program product comprising a computer usable medium having computer readable program code embodied therein, the program code [means] comprising:

a. program code configured to access a directory database, the database having a network protocol address for a selected plurality of processes having on-line status with respect to the computer network, the network protocol

address of each respective process forwarded to the database following connection to the computer network; and

b. program code responsive to one of the network protocol addresses and configured to establish a point-to-point communication link from the first process to the second process over the computer network.

44  
67

UN

(Amended) In a first computer process operatively coupled over a computer network to a second process and an address server, a method of establishing a point-to-point communication between the first and second processes comprising the steps of:

A. following connection of the first process to the computer network forwarding to the address server a network protocol address at which the first process is connected to the computer network;

[A.] B. querying the address server as to whether the second process is connected to the computer network;

[B.] C. receiving a network protocol address of the second process from the address server, when the second process is connected to the computer network; and

[C.] D. in [responsive] response to the network protocol address of the second process, establishing a point-to-point communication link with the second process over the computer network.

### Remarks

Applicants have considered carefully the Office Action dated October 28, 1998 and the references cited therein. In response, the claims have been amended. Applicants respectfully request reexamination and reconsideration of the application.

Claims 1-4, 6-11, 21, 23-24, 26-64, 66 and 67 have been examined and are rejected over various combinations of U.S. Patent 5,608,786(Gordon); U.S. Patent 5,740,231 (Cohn); U.S. Patent 5,524,254 (Morgan); and excerpts from The World Wide Web Unleashed (December). Before responding to the

-13-  
44

individual rejections set forth in the Office Action (Paper No. 23), Applicants request that the Examiner consider the following remarks.

In the office action, the Examiner has repeatedly stated that "[I]t would have been obvious to one of ordinary skill in the art at the time the invention was made to include a database and search retrieval mechanism to locate the needed network address because such mechanism permits the database to be modified over time to allow dynamic address assignment thus reducing the need to large address identifiers and thus the amount of data that needs to be transmitted with each packet of data."( Paper No. 23, paragraph 11).

Applicants respectfully note that this mischaracterization of the motivation for the invention was first introduced by the prior Examiner (Paper 18, paragraph 7).

Applicants' invention solves a fundamental problem associated with the Internet. The problem is not reducing the need for larger address identifiers. The problem is not the amount of data which needs to be transmitted with each packet over the network. The problem is: How can a global network user be located if he/she has no permanent network address?

Applicants have disclosed a solution to the above-described problem. The solution utilizes a client/ server system. In the disclosed system, a client process contacts a dedicated address directory server and forwards to the server the network protocol address to which it has been assigned upon connection to the computer network, along with other identification information. The dedicated address directory server maintains a compilation or list of entries, each of which contain a process identifier and the corresponding network protocol address forwarded to the server by the process itself. Other processes wishing to contact a desired target process simply query the address directory server to determine whether the target process is on-line and the current network protocol address at which the target process is located. The server forwards the network protocol address of the target process to the querying process. The querying process utilizes the information to establish a point-to-point communication with the target process.



The Examiner is relying primarily on Morgan to disclose a database containing one or more network addresses. The Examiner will note that although a database may be programmable or contain writable memory, such a database does not teach or suggest Applicants' inventive client/service system in which the client processes themselves update the database with their current information. This aspect distinguishes Applicants' system from the art of record.

Applicants have cancelled claims 1-4, and 6-11 without prejudice. Accordingly, any rejections of those claims are hereby deemed moot.

Applicants have made global amendments to the claims to ensure consistent use terminology throughout the claims and to conform the claims to 35 U.S.C. Section 112, 2nd paragraph. Specifically, the term "means" has been eliminated from the remaining pending claims. Also, all occurrences of "processors" have been changed to "process". Various other claims have been made for clarity sake. Such amendments are not necessitated by any reference cited by the Examiner but are offered to clarify the claim language and to more particularly point out and distinctly claim the subject matter which Applicants regard as their invention.

The Examiner has rejected the remaining pending claims under 35 USC §103 as being unpatentable over U.S. Patent 5,740,231 (Cohn et al.) in view of U.S. Patent 5,524,254 (Morgan et al.). Applicants respectfully assert that the claims, as amended, patentably distinguishes over the combined teachings of Cohn and Morgan for the following reasons. As stated by the Examiner, Cohn does not specify searching a database to match an address with a destination node. Although the sections of Morgan cited by the Examiner disclose an address recognition engine which reads each request and uses the address contained in the request as an index into an information database for look-up of a corresponding entry (Morgan, column 4, lines 44-56), the Examiner has failed to show where Morgan discloses a database in which the client process supply the database with their respective network addresses.

Claim 21 is directed to a computer program product for use with a computer system functioning as a client process in the inventive client/server

system of the subject application. Claim 21 has been amended to recite "program code for transmitting to the server a network protocol address received by the first process following connection to the computer network " (claim 21, lines 9-10). None of the references cited by the Examiner, whether considered singularly or in combination, disclose, teach or suggest a process or client process which forwards its network protocol address received upon connection to the computer network to a server. As discussed previously, the reporting or "logging-in" of a client process with an address directory server to provide the server with the current network protocol address at which the process can be located is not shown in the prior art.

Claim 23 is an apparatus claim directed to the server portion of Applicants' inventive system. Claim 23 has been amended to now recite an apparatus comprising a processor, a network interface and "a memory ... for storing a network protocol address for selected of a plurality of processes, each network protocol address stored in the memory following connection of the respective process to the computer network" (claim 23, lines 7-10). Claim 23 is believed patentable over the art of record, particularly the Morgan reference, as none of the references disclose or suggest, whether considered singularly or in combination the subject matter now claimed. Claim 24 includes all the limitations of claim 23 and is likewise believed patentable over the cited references for the same reasons as claim 23.

Claim 26 recites a method and has been amended similarly to claim 23. Specifically, claim 26 now recites a method for enabling point-to-point communication between a first process and a second process over a computer network including the step of "receiving and storing in a computer memory a respective network protocol address for selected of a plurality of processes that have an on-line status with respect to the computer network, each of the network protocol addresses received following connection of the respective process to the computer network" (claim 26, lines 6-11). As stated previously, none of the references of record, particularly Morgan et al., are believed to disclose a process for storing network protocol address in which the network protocol

address are received following connection of the process to the computer network. Claims 27-31 include all the limitations of claim 26 and are likewise believed patentable over the art of record for the same reasons as claim 26.

Applicants are puzzled by Examiner's assertion in Paragraphs 16 and 17 of the Office Action that claims 32-42 and 43-53 fail to teach or define beyond the subject matter of claims 1-4. Claims 32-42 are directed to a method for establishing a point-to-point communication link with the user interface of a client process by associating elements representing a communication line and various processes. None of the references cited by the Examiner, including Gordon, Morgan, Cohn and December disclose or suggest a user interface or a technique for establishing communications by manipulation of user interface elements. Claims 43-53 are computer program product claims and are directed to a computer program product containing program code for performing a process similar to the method defined in claims 32-42. Applicants respectfully assert that claims 32-53 with, or without the current amendments patentably distinguish over the cited references, whether considered singularly or in combination. Applicants respectfully assert that the Examiner has failed to disclose where any of the cited references teach or suggest a user interface for establishing point-to-point communications by associating user interface elements representing various processes and communication lines.

Claim 54 recites a method of locating a process over a computer network comprising the step of "maintaining an Internet accessible list having a plurality of selected entries, each entry comprising an identifier and a corresponding Internet protocol address of a process currently connected to the Internet, the Internet protocol address added to the list following connection of the process to the computer network" (claim 54, lines 3-7). For reasons similar to those stated with reference to claims 23 and 26, claim 54 is believed patentable over the art of record.

Claim 55 also recites a method of locating processes over a computer network. Claim 55 has been amended to include the step of "maintaining, in a computer memory, a network accessible compilation of entries, selected of the

entries comprising a network protocol address and a corresponding identifier of a process connected to the computer network, the network protocol address of the corresponding process assigned to the process upon connection to the computer network (claim 55, lines 4-9). Claim 60 is a computer program product claim having similar limitations to claim 55. Specifically, claim 60 recites a computer program product comprising "program code configured to maintain the computer memory, a network accessible compilation of entries, selected of the entries comprising a network protocol address and a corresponding identifier of a process connected to the computer network, the network protocol address of the corresponding process assigned to the process upon connection to the computer network" (claim 60, lines 6-11). Claims 55 and 60 and their subsequent dependent claims are believed patentable over the art of record. The Examiner has not shown where any of the cited references disclose or suggest a database for storing network protocol addresses where the network protocol addresses have been assigned to a process upon the processes connection to the computer network, as now claimed.

Claim 66 is directed to a computer program product for use with a client process in accordance with the inventive client/server system of the present invention. Specifically, claim 66 recites a computer program product comprising program code configured to access a directory database, the database having a network protocol address for a selected plurality of processes having online status with respect to the computer network, the network protocol address of each respective process forwarded to the database following connection to the computer network" (claim 66, lines 7-11). Claim 66 is believed patentable over the art of record substantially for the same reasons as claim 21.

Claim 67 is directed to a method of a client process in the inventive client/server system of the present invention, specifically, claim 67 recites a method of establishing a point-to-point communication between first and second processes comprising the step of "following connection of the first process to the computer network, forwarding to the address server a network protocol address at which the first process is connected to the computer network" (claim 67, lines

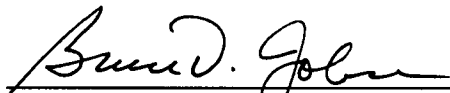
5-7). Applicants respectfully assert that claim 67 is patentably distinct over the art of record, whether considered singularly or in combination since none of the cited references disclose, teach or suggest a client process which forwards its network protocol address to an address server following connection of the process to the computer network.

Applicants' submit herewith a supplemental Information Disclosure Statement with this response containing references which have been made of record in co-pending application Serial No. 08/721,316.

In light of the foregoing amendments to the claims, Applicants respectfully assert that all claims currently under consideration now patentably distinguish over the art of record, including the cited references, whether considered singularly or in combination. The Examiner is respectfully requested to advance this case to issuance and send a notice to that effect. In the event that outstanding issues remain following the Examiner's review of this response, Applicants' attorney requests that the Examiner contact Applicants' attorney at the number listed below to set up a telephone interview to attempt to resolve any outstanding issues with the claims and before any further Office Actions are issued.

The Commissioner is hereby authorized to charge any fees or credits under 37 C.F.R. §1.16 and 1.17 to our deposit account No. 02-3038.

Respectfully submitted



Date: 3/1/99

Bruce D. Jobse, Esq. Reg. No. 33,518  
KUDIRKA & JOBSE, LLP  
Customer Number 021127  
Tel: (617) 367-4600 Fax: (617) 367-4656

2756 \$



<b>AMENDMENT TRANSMITTAL</b>		Docket No. N0003/7000
Applicant:	Glenn W. Hutton; et al.	
Serial No.	08/533,115	
Filed:	September 25, 1995	
For:	METHOD AND APPARATUS FOR ESTABLISHING POINT-TO-POINT COMMUNICATIONS OVER A COMPUTER NETWORK	
Examiner:	M. Rinehart	
Art Unit:	2756	

Assistant Commissioner for Patents  
 Washington, DC 20231  
 Box Non-Fee Amendment

**RECEIVED**  
 MAR 10 1999  
 Group 2700

Transmitted herewith for filing is the following:

**Enclosures**

- Amendment
- Petition for a 1 month Extension of Time
- Information Disclosure Statement
- Return Receipt Postcard

**Small Entity**

- A small entity statement under 37 C.F.R. §1.27 has already been filed.
- A small entity statement under 37 C.F.R. §1.27 is attached

**Fees**

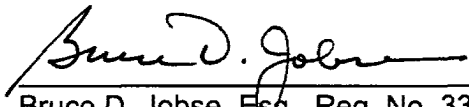
Claims as Filed					
	Claims Filed	Highest Number Paid for	Number of Extra Claims	Rate	Additional Fees Due
Total Claims (37 CFR §1.16(c))	48	- 68 =	0 X	\$18.00 =	\$ 0.00
Independent Claims (37 CFR §1.16(b))	13	- 19 =	0 X	\$78.00 =	\$ 0.00
<b>Extension Fee</b>					<b>\$ 110.00</b>
<b>Reduction by 50% for filing by small entity</b>					<b>\$ 0.00</b>
<b>Total Filing Fee</b>					<b><u>\$ 110.00</u></b>

**Payment**

- Check in the amount of the total filing fee.
- Charge Account No. 02-3038 in the amount of the total filing fee. A duplicate of this transmittal sheet is attached.

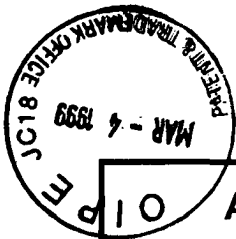
**Authorization to Charge Additional Fees**

- The Commissioner is hereby authorized to charge any additional fees under 37 C.F.R. §1.16 and §1.17 required by the attached paper and during the entire pendency of this application to Account No. 02-3038.



Date: 3/1/99

Bruce D. Jobse, Esq. Reg. No. 33,518  
KUDIRKA & JOBSE, LLP  
Customer Number 021127  
Tel: (617) 367-4600 Fax: (617) 367-4656



<b>AMENDMENT TRANSMITTAL</b>		Docket No. N0003/7000
Applicant:	Glenn W. Hutton, et al.	
Serial No.	08/533,115	
Filed:	September 25, 1995	
For:	METHOD AND APPARATUS FOR ESTABLISHING POINT-TO-POINT COMMUNICATIONS OVER A COMPUTER NETWORK	
Examiner:	M. Rinehart	
Art Unit:	2756	

Assistant Commissioner for Patents  
 Washington, DC 20231  
 Box Non-Fee Amendment

Transmitted herewith for filing is the following:

**Enclosures**

- Amendment
- Petition for a 1 month Extension of Time
- Information Disclosure Statement
- Return Receipt Postcard

**Small Entity**

- A small entity statement under 37 C.F.R. §1.27 has already been filed.
- A small entity statement under 37 C.F.R. §1.27 is attached

**Fees**

Claims as Filed					
	Claims Filed	Highest Number Paid for	Number of Extra Claims	Rate	Additional Fees Due
Total Claims (37 CFR §1.16(c))	48	- 68 =	0 X	\$18.00 =	\$ 0.00
Independent Claims (37 CFR §1.16(b))	13	- 19 =	0 X	\$78.00 =	\$ 0.00
<b>Extension Fee</b>					<b>\$ 110.00</b>
<b>Reduction by 50% for filing by small entity</b>					<b>\$ 0.00</b>
<b>Total Filing Fee</b>					<b><u>\$ 110.00</u></b>

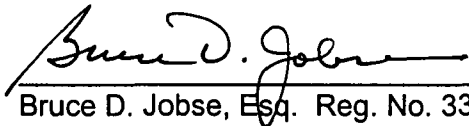


**Payment**

- Check in the amount of the total filing fee.  
 Charge Account No. 02-3038 in the amount of the total filing fee. A duplicate of this transmittal sheet is attached.

**Authorization to Charge Additional Fees**

- The Commissioner is hereby authorized to charge any additional fees under 37 C.F.R. §1.16 and §1.17 required by the attached paper and during the entire pendency of this application to Account No. 02-3038.



Date: 3/1/99

Bruce D. Jobse, Esq. Reg. No. 33,518  
KUDIRKA & JOBSE, LLP  
Customer Number 021127  
Tel: (617) 367-4600 Fax: (617) 367-4656



UNITED STATES DEPARTMENT OF COMMERCE  
Patent and Trademark Office

**NOTICE OF ALLOWANCE AND ISSUE FEE DUE**

021127  
KUDIRKA & JOBSE  
TWO CENTER PLAZA  
BOSTON MA 02108

LM51/0525

APPLICATION NO.	FILING DATE	TOTAL CLAIMS	EXAMINER AND GROUP ART UNIT	DATE MAILED
08/533,115	09/25/95	044	RINEHART, M	05/25/99
First Named Applicant	HUTTON,		35 USC 154(b) term ext. =	0 Days.

TITLE OF INVENTION: POINT-TO-POINT INTERNET PROTOCOL

ATTY'S DOCKET NO.	CLASS-SUBCLASS	BATCH NO.	APPLN. TYPE	SMALL ENTITY	FEE DUE	DATE DUE
2 649-2	709-227.000	T56	UTILITY	YES	\$605.00	08/25/99

**THE APPLICATION IDENTIFIED ABOVE HAS BEEN EXAMINED AND IS ALLOWED FOR ISSUANCE AS A PATENT. PROSECUTION ON THE MERITS IS CLOSED.**

**THE ISSUE FEE MUST BE PAID WITHIN THREE MONTHS FROM THE MAILING DATE OF THIS NOTICE OR THIS APPLICATION SHALL BE REGARDED AS ABANDONED. THIS STATUTORY PERIOD CANNOT BE EXTENDED.**

**HOW TO RESPOND TO THIS NOTICE:**

- I. Review the SMALL ENTITY status shown above.  
If the SMALL ENTITY is shown as YES, verify your current SMALL ENTITY status:
- A. If the status is changed, pay twice the amount of the FEE DUE shown above and notify the Patent and Trademark Office of the change in status, or
  - B. If the status is the same, pay the FEE DUE shown above.

- If the SMALL ENTITY is shown as NO:
- A. Pay FEE DUE shown above, or
  - B. File verified statement of Small Entity Status before, or with, payment of 1/2 the FEE DUE shown above.

II. Part B-Issue Fee Transmittal should be completed and returned to the Patent and Trademark Office (PTO) with your ISSUE FEE. Even if the ISSUE FEE has already been paid by charge to deposit account; Part B Issue Fee Transmittal should be completed and returned. If you are charging the ISSUE FEE to your deposit account, section "4b" of Part B-Issue Fee Transmittal should be completed and an extra copy of the form should be submitted.

III. All communications regarding this application must give application number and batch number. Please direct all communications prior to issuance to Box ISSUE FEE unless advised to the contrary.

**IMPORTANT REMINDER: Utility patents issuing on applications filed on or after Dec. 12, 1980 may require payment of maintenance fees. It is patentee's responsibility to ensure timely payment of maintenance fees when due.**

PATENT AND TRADEMARK OFFICE COPY

02/533115



UNITED STATES DEPARTMENT OF COMMERCE  
Patent and Trademark Office

Address: COMMISSIONER OF PATENTS AND TRADEMARKS  
Washington, D.C. 20231

APPLICATION NUMBER	FILING DATE	FIRST NAMED APPLICANT	ATTORNEY DOCKET NO.
--------------------	-------------	-----------------------	---------------------

08/533,115 09/25/95 HUTTON

EXAMINER

021127  
KUBIRKA & JOBSE  
TWO CENTER PLAZA  
BOSTON MA 02108

LM51/0525

ART UNIT PAPER NUMBER

29

DATE MAILED:

05/25/99

This is a communication from the examiner in charge of your application.  
COMMISSIONER OF PATENTS AND TRADEMARKS

NOTICE OF ALLOWABILITY

All claims being allowable, PROSECUTION ON THE MERITS IS (OR REMAINS) CLOSED in this application. If not included herewith (or previously mailed), a Notice of Allowance and Issue Fee Due or other appropriate communication will be mailed in due course.

This communication is responsive to amendment 3/4/99 (Paper # 29)

The allowed claim(s) is/are 21, 23-24, 26-64, 66, 67 renumbered 1-44

The drawings filed on \_\_\_\_\_ are acceptable.

Acknowledgement is made of a claim for foreign priority under 35 U.S.C. § 119(a)-(d).

All  Some\*  None of the CERTIFIED copies of the priority documents have been

received.

received in Application No. (Series Code/Serial Number) \_\_\_\_\_

received in this national stage application from the International Bureau (PCT Rule 17.2(a)).

\*Certified copies not received: \_\_\_\_\_

Acknowledgement is made of a claim for domestic priority under 35 U.S.C. § 119(e).

A SHORTENED STATUTORY PERIOD FOR RESPONSE to comply with the requirements noted below is set to EXPIRE THREE MONTHS FROM THE "DATE MAILED" of this Office action. Failure to timely comply will result in ABANDONMENT of this application. Extensions of time may be obtained under the provisions of 37 CFR 1.136(a).

Note the attached EXAMINER'S AMENDMENT or NOTICE OF INFORMAL APPLICATION, PTO-152, which discloses that the oath or declaration is deficient. A SUBSTITUTE OATH OR DECLARATION IS REQUIRED.

Applicant MUST submit NEW FORMAL DRAWINGS

because the originally filed drawings were declared by applicant to be informal.

including changes required by the Notice of Draftperson's Patent Drawing Review, PTO-948, attached hereto or to Paper No. 18

including changes required by the proposed drawing correction filed on \_\_\_\_\_, which has been approved by the examiner.

including changes required by the attached Examiner's Amendment/Comment.

Identifying indicia such as the application number (see 37 CFR 1.84(c)) should be written on the reverse side of the drawings. The drawings should be filed as a separate paper with a transmittal letter addressed to the Official Draftperson.

Note the attached Examiner's comment regarding REQUIREMENT FOR THE DEPOSIT OF BIOLOGICAL MATERIAL.

Any response to this letter should include, in the upper right hand corner, the APPLICATION NUMBER (SERIES CODE/SERIAL NUMBER). If applicant has received a Notice of Allowance and Issue Fee Due, the ISSUE BATCH NUMBER and DATE of the NOTICE OF ALLOWANCE should also be included.

Attachment(s)

Notice of References Cited, PTO-892

Information Disclosure Statement(s), PTO-1449, Paper No(s). 26

Notice of Draftperson's Patent Drawing Review, PTO-948

Notice of Informal Patent Application, PTO-152

Interview Summary, PTO-413

Examiner's Amendment/Comment

Examiner's Comment Regarding Requirement for Deposit of Biological Material

Examiner's Statement of Reasons for Allowance

Mark H. Rinehart  
Primary Examiner

D

#29 D  
S. Bond  
Page 2  
5/24/99

**EXAMINER'S AMENDMENT**

1. An examiner's amendment to the record appears below. Should the changes and/or additions be unacceptable to applicant, an amendment may be filed as provided by 37 CFR 1.312. To ensure consideration of such an amendment, it **MUST** be submitted no later than the payment of the issue fee.
2. The application has been amended as follows:

**IN THE CLAIMS:**

~~Cancel claims 5, 12-20, 22, 25, 65, and 68 without prejudice or disclaimer.~~

3. This application is in condition for allowance except for the presence of claims 5, 12-20, 22, 25, 65, and 68 to Inventions II, II, and IV non-elected without traverse in Paper No. 22. Accordingly, claims 5, 12-20, 22, 25, 65, and 68 have been cancelled.

D

Art Unit: 2756

4. Any inquiry concerning this communication or earlier communications from the examiner should be directed to Primary Examiner Rinehart whose telephone number is (703) 305-4815. The examiner can normally be reached on Monday through Thursday from 8:00 AM - 5:30 PM. The examiner can also be reached on alternate Fridays.

If attempts to reach the examiner by telephone are unsuccessful, the examiner's supervisor, Supervisory Primary Examiner Frank J. Asta, can be reached on (703) 305-3817. The fax phone number for Examining Group 2300 is (703) 305-9731.

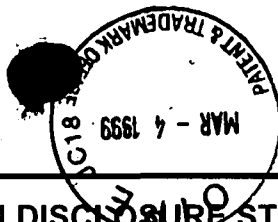
Any inquiry of a general nature or relating to the status of this application should be directed to the Group receptionist whose telephone number is (703) 305-3900.

Mark H. Rinehart  
Primary Examiner  
Art Unit 2302



A handwritten signature in black ink, appearing to read "Mark H. Rinehart".

**Mark H. Rinehart**  
**Primary Examiner**



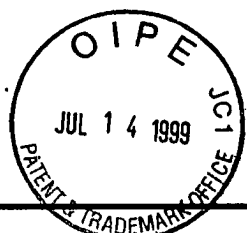
<b>INFORMATION DISCLOSURE STATEMENT BY APPLICANT Sheet 1 of 1</b>	Docket No. N0003/7000
Applicant: Glenn W. Hutton, et al. Serial No. 08/533,115 Filed: September 25, 1995 For: METHOD AND APPARATUS FOR ESTABLISHING POINT-TO-POINT COMMUNICATIONS OVER A COMPUTER NETWORK Examiner: M. Rinehart Art Unit: 2756	<b>RECEIVED</b> <b>MAR 10 1999</b> Group 2700

OTHER PRIOR ART - NON PATENT LITERATURE AND DOCUMENTS			
Exam Inits	Cite No.	Include name of the author (in CAPITAL LETTERS), title of the articles (when appropriate), title of the item (book, magazine, journal, serial, symposium, catalog, etc.), date, page(s), volume-issue number(s), publisher, city and/or country where published.	T
K		VocalTec Internet Phone (TM) Version 2.5, <a href="http://www.cox.smu.edu/class/mis6386/people/stort/phone25.exe">www.cox.smu.edu/class/mis6386/people/stort/phone25.exe</a>	<input type="checkbox"/>
K		Weinberg, Netscape Conference and Cooltalk Meeting Room, <a href="http://www.q5.com">www.q5.com</a>	<input type="checkbox"/>
R		Gull, Re: Getting IP address of PPP-connected Mac, <jgull-0304951005350001@pm012-11.dialip.mich.net>	<input type="checkbox"/>
WR		Gull, Re: Internet Phone for Mac?, >jgull-1704950116450001@pm049-28.dialip.mich.net>	<input type="checkbox"/>
			<input type="checkbox"/>
			<input type="checkbox"/>
			<input type="checkbox"/>
			<input type="checkbox"/>
			<input type="checkbox"/>
			<input type="checkbox"/>

Examiner Signature	<b>Mark H. Rinehart</b> Primary Examiner	Date Considered	5/13/99
--------------------	---	-----------------	---------

ENTER 312

MR 312



#33E(NF)  
8.30  
2/8/90

<b>AMENDMENT AFTER ALLOWANCE UNDER 37 CFR §1.312(a)</b>	Docket No. N0003/7000
Applicant: Glenn W. Hutton, et al. Serial No. 08/533,115 Filed: September 25, 1995 For: METHOD AND APPARATUS FOR ESTABLISHING POINT-TO-POINT COMMUNICATIONS OVER A COMPUTER NETWORK Examiner: R.H. Rinehart Art Unit: 2756	

**CERTIFICATE OF EXPRESS MAILING**

"Express Mail" mailing label number: EL445948630US  
Date of Deposit: July 14, 1999

I hereby certify that the following Correspondence is being deposited with the United States Postal Service "Express Mail Post Office to Addressee" service pursuant to 37 C.F.R. §1.10 on the date indicated above in an envelope addressed to Commissioner of Patents and Trademarks, BOX ISSUE FEE, Washington, D.C. 20231.

*Frances M. Cunningham*  
Frances M. Cunningham

Assistant Commissioner for Patents  
Washington, D.C. 20231

Sir:

Prior to issuance, Applicants request the above-identified application be amended as follows:

*entered per paper #34. dsf 6-21-00*

**In the Claims**

Claim 33, line 3, change "callee; process" to -- callee process; --.

Claim 35, line 1, change "step" to -- steps --.

Claim 60, line 8, after "computer network" insert -- , --.

**Remarks**

This application is currently under Allowance. A Notice of Allowance dated May 25, 1999 was mailed indicating that claims 21, 23-24, 26-64, and 66-67 are allowed. Applicants submit this Amendment to resolve minor formalities in the application.

Applicants have amended claims 33, 35 and 60 to correct minor grammatical errors within the claims, as allowed.

Also, submitted herewith are Supplemental Declarations Under 37 CFR Section 1.63 for each of the named inventors in the application.

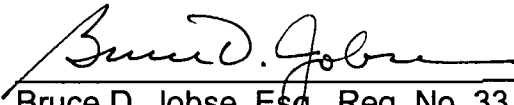
With the Amendment mailed December 2, 1997, a Declaration of Prior Invention Under 37 CFR Section 1.131 of inventor Glenn W. Hutton was submitted. At that time, the petition to add inventors Mattaway and Strickland had not yet been granted. Upon recommendation of the USPTO Solicitor's Office, Applicants now submit herewith Supplemental Declarations of Prior Invention Under 37 CFR Section 1.131 of subsequently named inventors Mattaway and Strickland. These Declarations of Prior Invention of inventors Mattaway and Strickland corroborate and confirm the Declaration of Prior Invention of inventor Hutton.

Applicants also submit herewith formal drawings for Figs. 1-9 and a Letter to the Official Draftsman.

No new matter or substantive issues are believed raised by this amendment. In light of the foregoing amendments and remarks, this application is now believed in condition for issuance and the Examiner is respectfully requested to advance this application to issuance. If the Examiner has any further questions regarding this Amendment, he is invited to call Applicants' attorney at the number listed below.

The Commissioner is hereby authorized to charge any fees or credits under 37 C.F.R. §1.16 and 1.17 to our deposit account No. 02-3038.

Respectfully submitted



Date: 7/14/99

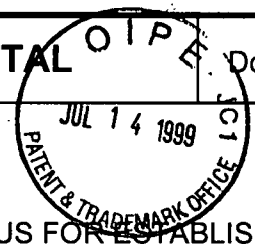
Bruce D. Jobse, Esq. Reg. No. 33,518  
KUDIRKA & JOBSE, LLP  
Customer Number 021127  
Tel: (617) 367-4600 Fax: (617) 367-4656





ALL B/L

<b>AMENDMENT TRANSMITTAL</b>		Docket No. N0003/7000
Applicant:	Glenn W. Hutton, et al.	
Serial No.	08/533,115	
Filed:	September 25, 1995	
For:	METHOD AND APPARATUS FOR ESTABLISHING POINT-TO-POINT COMMUNICATIONS OVER A COMPUTER NETWORK	
Examiner:	R.H. Rinehart	
Art Unit:	2756	



**CERTIFICATE OF EXPRESS MAILING**

"Express Mail" mailing label number: EL445948630US  
Date of Deposit: July 14, 1999

I hereby certify that the following Correspondence is being deposited with the United States Postal Service "Express Mail Post Office to Addressee" service pursuant to 37 C.F.R. §1.10 on the date indicated above in an envelope addressed to Commissioner of Patents and Trademarks, Washington, D.C. 20231.

*Frances M. Cunningham*  
Frances M. Cunningham

Assistant Commissioner for Patents  
BOX ISSUE FEE  
Washington, DC 20231

Transmitted herewith for filing is the following:

**Enclosures**

- Amendment After Allowance
- Petition for a month Extension of Time
- Return Receipt Postcard
- Declaration of Prior Invention (Mattaway and Strickland)
- Supplemental Declaration (Hutton, Mattaway and Strickland)
- Formal Drawings of Figures 1-9
- Letter to Official Draftsman

**Small Entity**

- A small entity statement under 37 C.F.R. §1.27 has already been filed.
- A small entity statement under 37 C.F.R. §1.27 is attached

**RECEIVED**

AUG 6 1999

Publishing Division  
Corres/Allowed Files (04)

PRODUCTION CONTROL  
PUBLISHING DIVISION  
OIPE/JCWS

RECEIVED  
AUG - 3 1999

RECEIVED

RECEIVED  
JUL 29 1999

RECEIVED

**Fees**

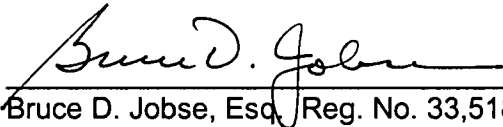
Claims as Filed					
	Claims Filed	Highest Number Paid for	Number of Extra Claims	Rate	Additional Fees Due
Total Claims (37 CFR §1.16(c))	68	- 68 =	0 X	\$18.00 =	\$ 0.00
Independent Claims (37 CFR §1.16(b))	19	- 19 =	0 X	\$78.00 =	\$ 0.00
<b>Extension Fee</b>					<b>\$ 0.00</b>
<b>Reduction by 50% for filing by small entity</b>					<b>\$ 0.00</b>
<b>Total Filing Fee</b>					<b>\$ <u>0.00</u></b>

**Payment**

- Check in the amount of the total filing fee.
- Charge Account No. 02-3038 in the amount of the total filing fee. A duplicate of this transmittal sheet is attached.

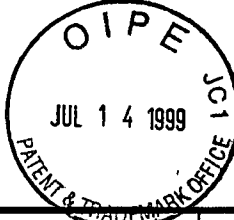
**Authorization to Charge Additional Fees**

- The Commissioner is hereby authorized to charge any additional fees under 37 C.F.R. §1.16 and §1.17 required by the attached paper and during the entire pendency of this application to Account No. 02-3038.

  
 Bruce D. Jobse, Esq. Reg. No. 33,518  
 KUDIRKA & JOBSE, LLP

Date: 7/14/99

Customer Number 021127  
 Tel: (617) 367-4600 Fax: (617) 367-4656



#34  
S. Bond  
2/8/00

<b>LETTER TO OFFICIAL DRAFTSPERSON</b>	Docket No. N0003/7000
Applicant: Glenn W. Hutton, et al. Serial No: 08/533,115 Filed: September 25, 1995 For: METHOD AND APPARATUS FOR ESTABLISHING POINT-TO-POINT COMMUNICATIONS OVER A COMPUTER NETWORK Examiner: R.H. Rinehart Art Unit: 2756	

**CERTIFICATE OF EXPRESS MAILING**

"Express Mail" mailing label number: EL445948630US  
Date of Deposit: July 14, 1999

I hereby certify that the following Correspondence is being deposited with the United States Postal Service "Express Mail Post Office to Addressee" service pursuant to 37 C.F.R. §1.10 on the date indicated above in an envelope addressed to Commissioner of Patents and Trademarks, BOX ISSUE FEE, Washington, D.C. 20231.

*Frances M. Cunningham*  
Frances M. Cunningham

Assistant Commissioner for Patents  
Box Issue Fee  
Washington, DC 20231

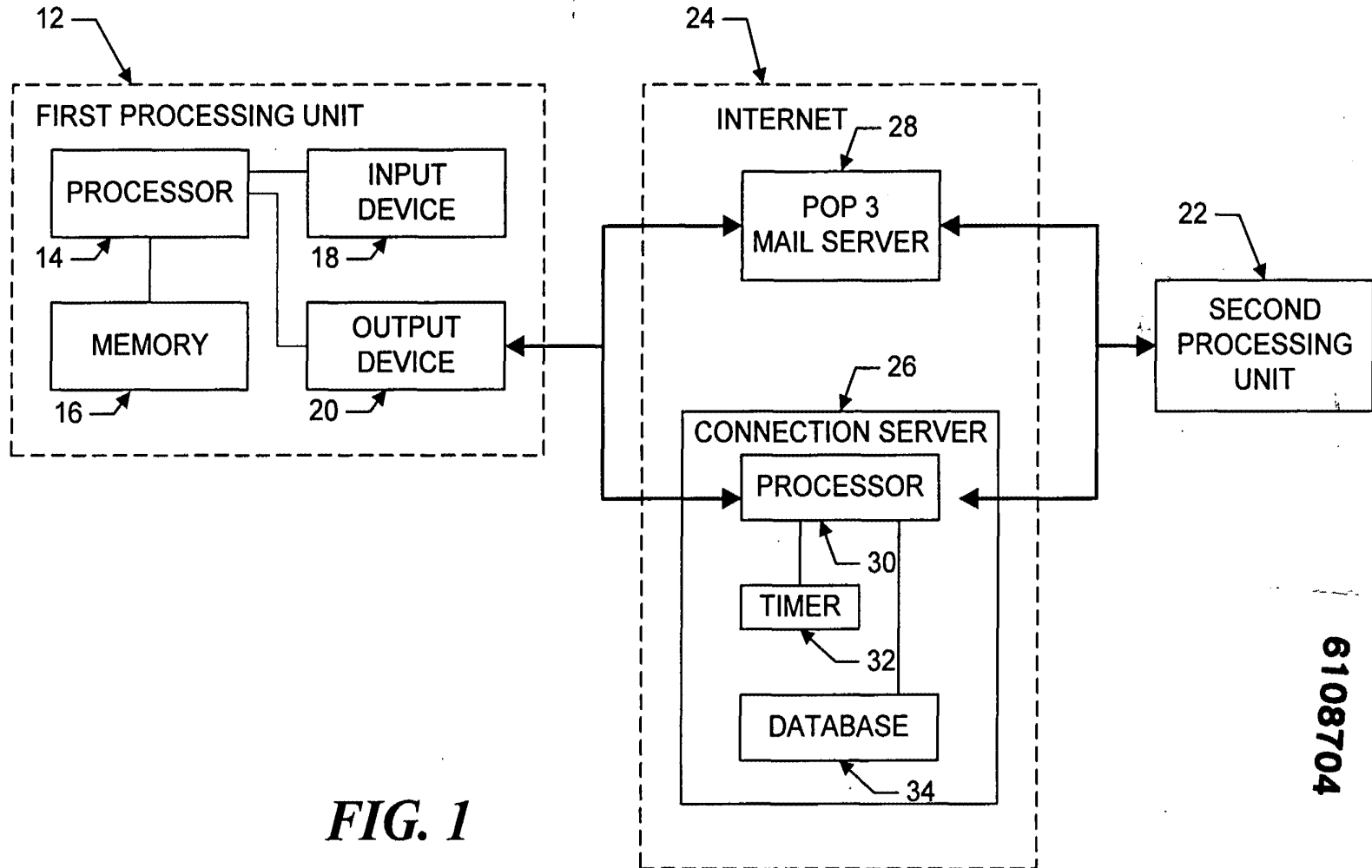
1. Upon approval of the Examiner in charge of the above-identified application, please substitute the enclosed drawing sheets containing formal versions of Figures 1-9 for the corresponding drawing sheets currently in the application.
2. The Commissioner is hereby authorized to charge any other fees under 37 CFR §1.16 and §1.17 that may be required, or credit any overpayment, to our Deposit Account No. 02-3038.

Respectfully submitted,

*Bruce D. Jobse*

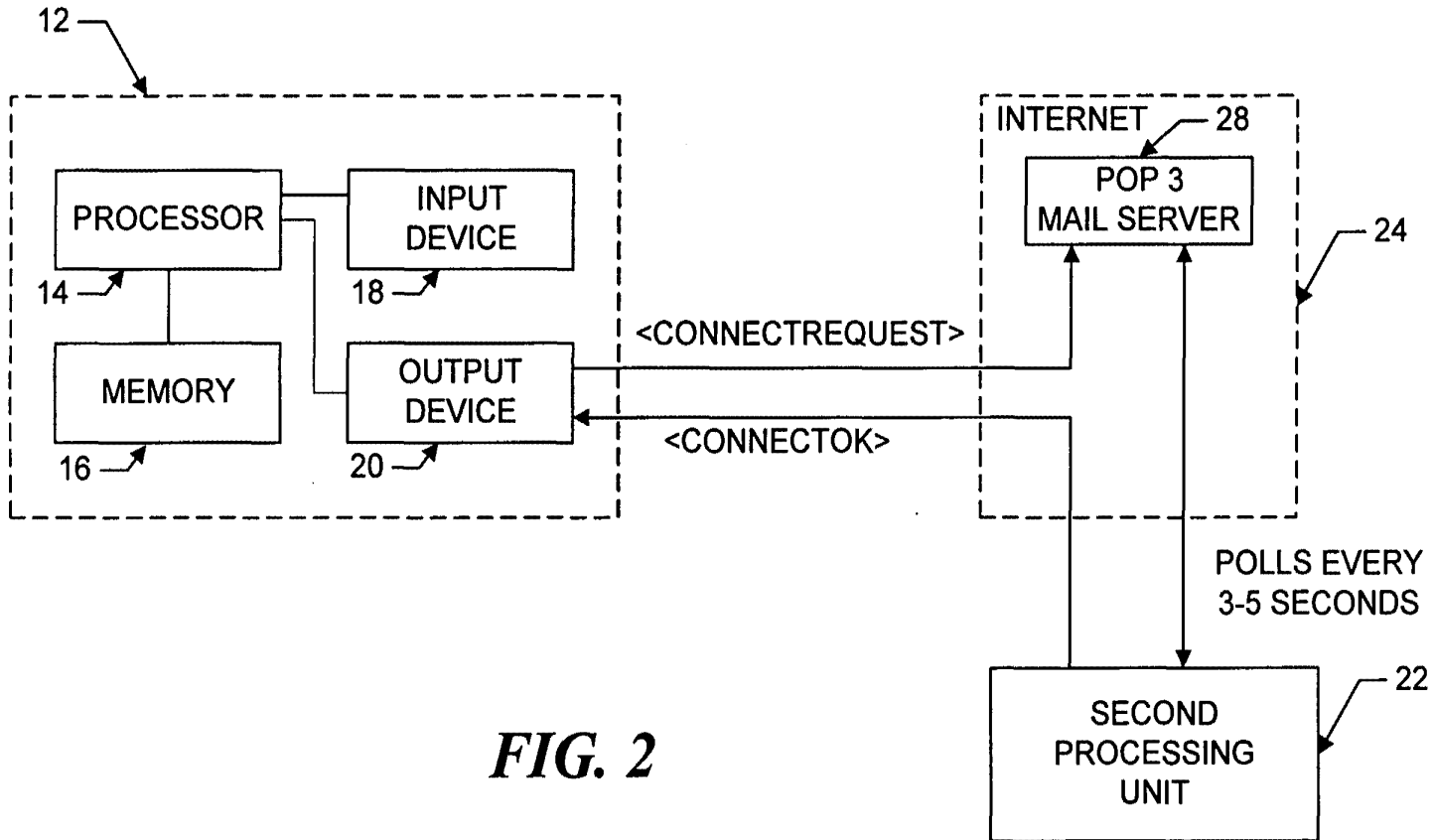
Date: 7/14/99

Bruce D. Jobse, Esq. Reg. No. 33,518  
KUDIRKA & JOBSE, LLP  
Customer Number 021127  
Tel: (617) 367-4600 Fax: (617) 367-4656

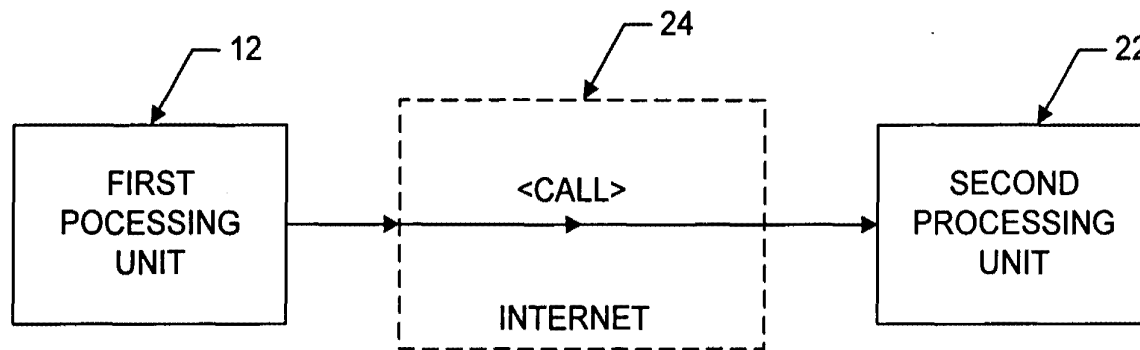


**FIG. 1**

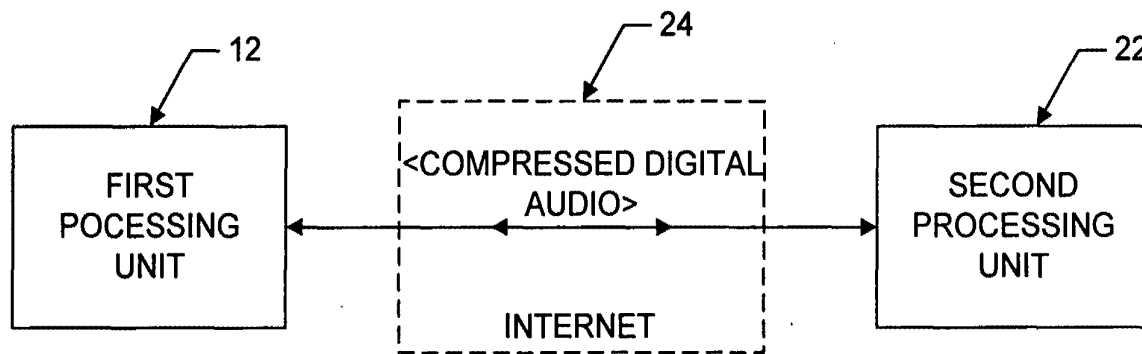
**6108704**



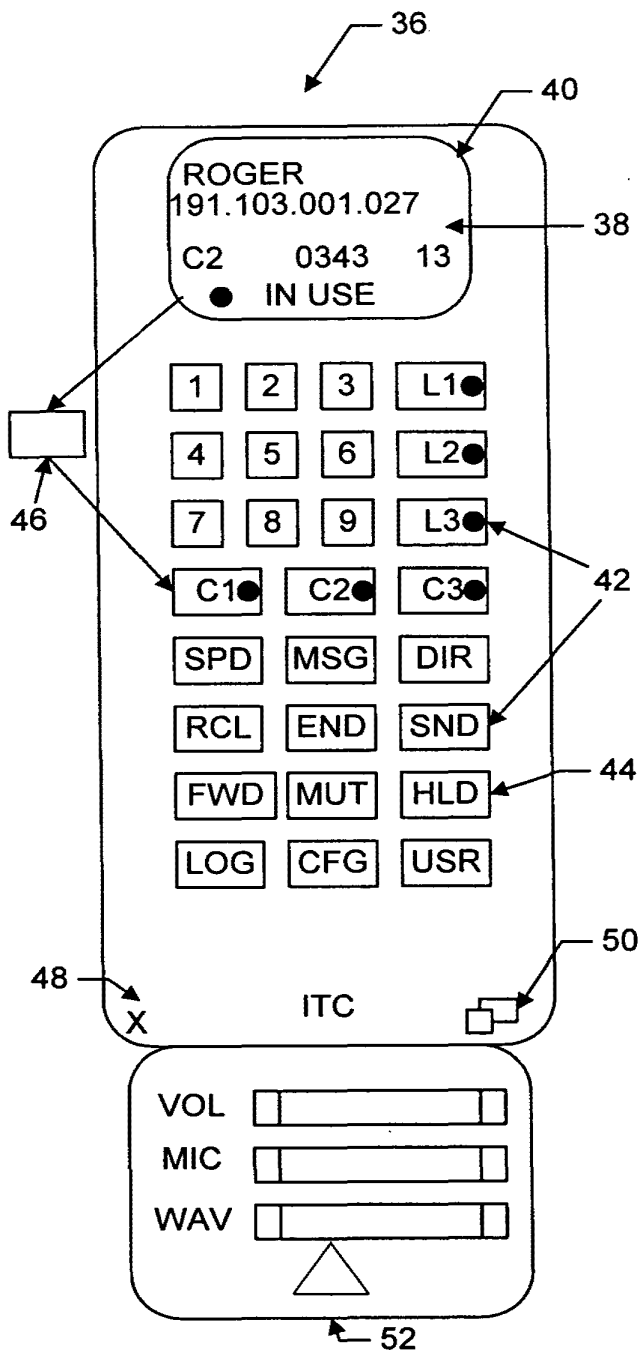
**FIG. 2**



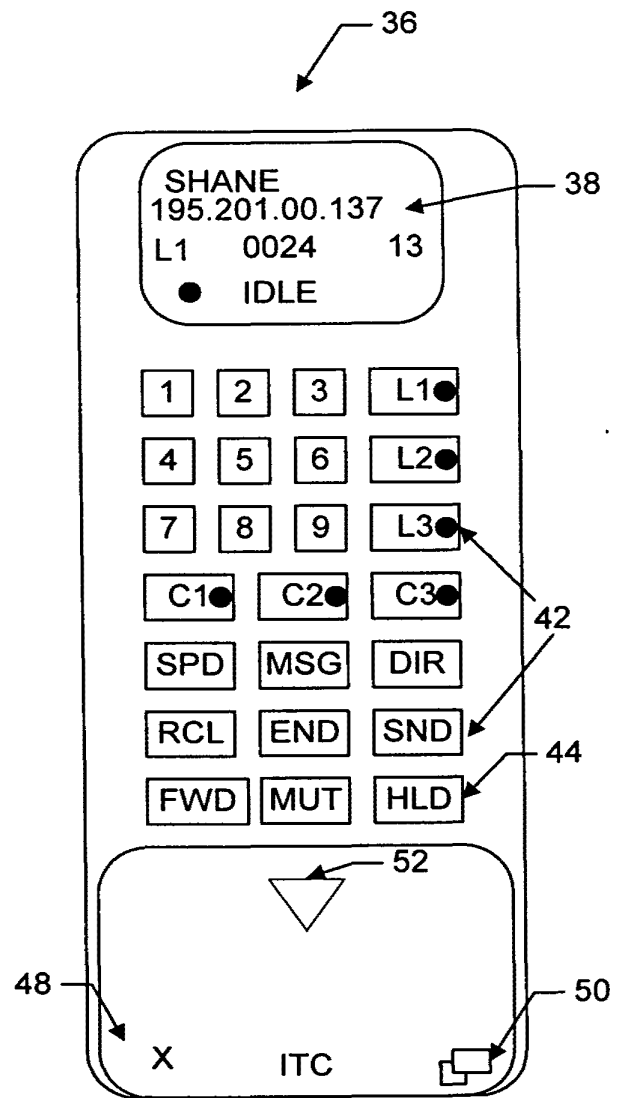
**FIG. 3**



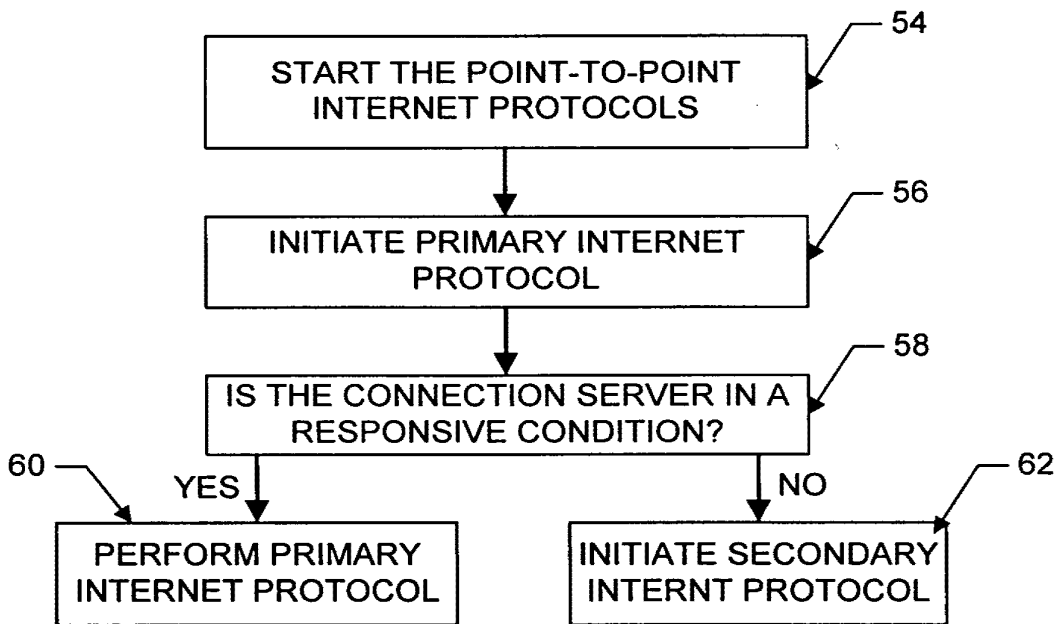
**FIG. 4**



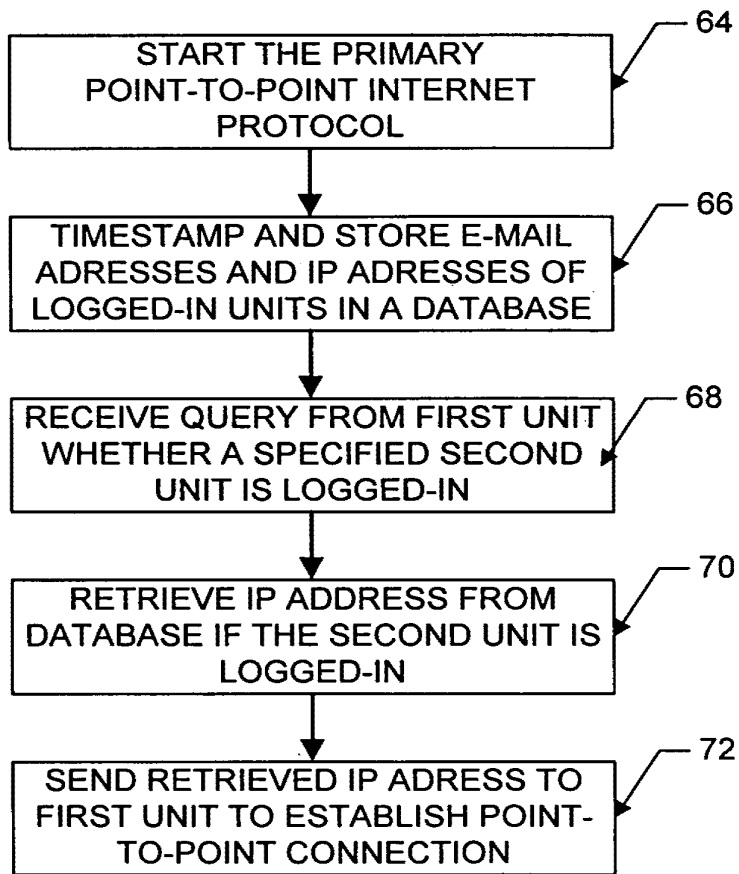
**FIG. 5**



**FIG. 6**

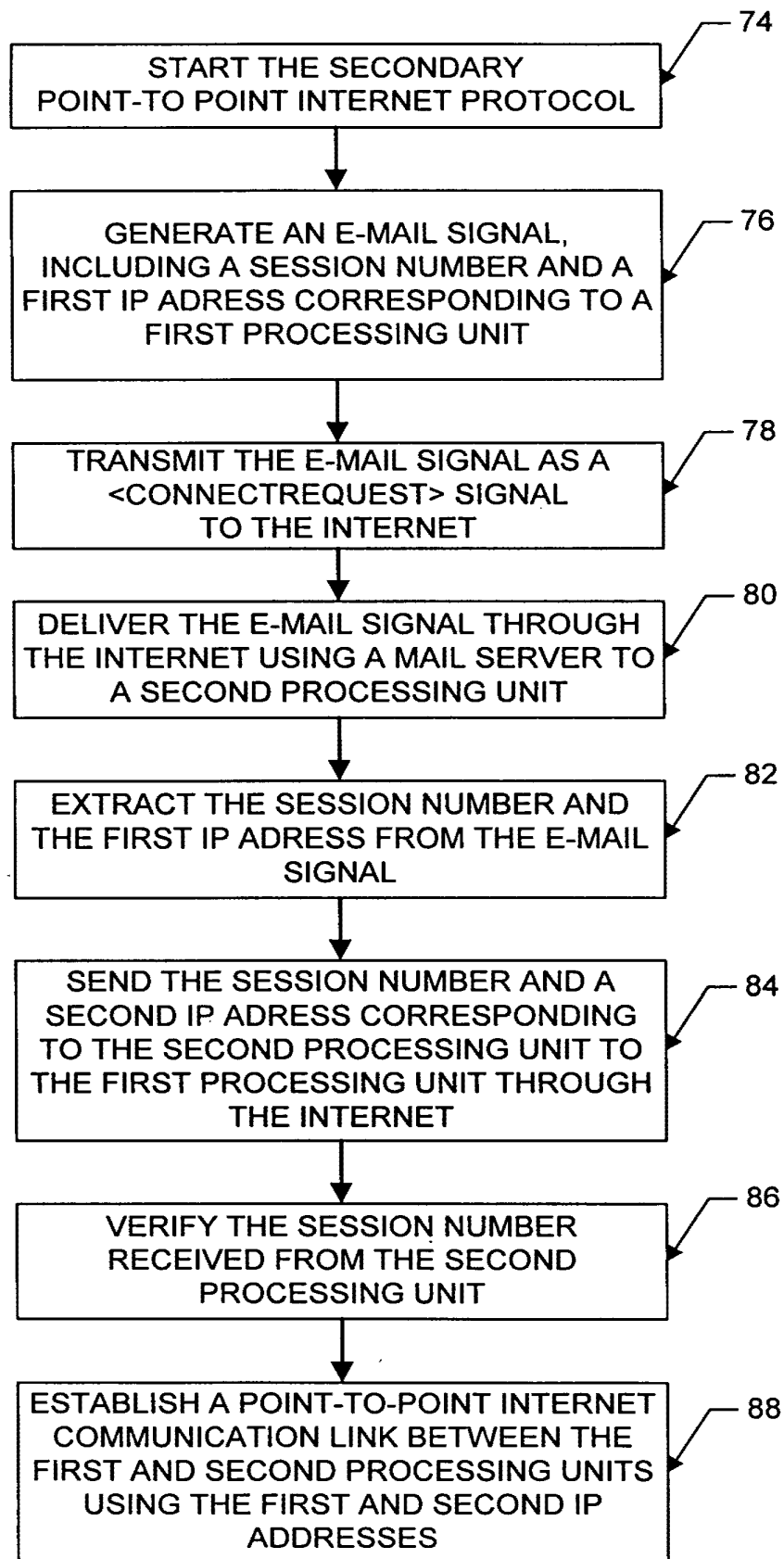


**FIG. 7**



**FIG. 8**





**FIG. 9**

# 30  
830nd  
2/8/00

IN THE UNITED STATES PATENT AND TRADEMARK OFFICE

Applicant: Glenn W. Hutton et al.  
Serial No.: 08/533,115  
Filed: September 25, 1995  
For: POINT-TO-POINT INTERNET PROTOCOL  
Examiner: M. H. Rinehart  
Art Unit: 2756



CERTIFICATE OF EXPRESS MAILING

"Express Mail" mailing label number: EL445948630US  
Date of Deposit: July 14, 1999

I hereby certify that the following Correspondence is being deposited with the United States Postal Service "Express Mail Post Office to Addressee" service pursuant to 37 C.F.R. §1.10 on the date indicated above in an envelope addressed to Commissioner of Patents and Trademarks, BOX ISSUE FEE, Washington, D.C. 20231.

*Frances M. Cunningham*  
Frances M. Cunningham

Assistant Commissioner for Patents  
Washington, D.C. 20231

**DECLARATION OF PRIOR INVENTION IN THE UNITED STATES TO OVERCOME  
CITED PATENT UNDER 37 CFR 1.131**

Sir/Madam:

This declaration is to establish completion of the invention in this application in the United States at a date prior to May 23, 1995, the effective date of prior art patent 5,581,552, cited by the Examiner. The undersigned Declarant was added as a named Inventor in the above-identified patent application. The Declarant's statements set forth below establishes conception of the invention prior to the effective date of the reference coupled with due diligence from prior to the effective date of reference to filing of the application. Exhibit B is submitted herewith to support the Declarant's statements. This Declaration is submitted prior to final rejection or payment of the issue fee in the application.

1. I am the named inventor in the United States Patent Application 08/533,115, filed September 25, 1995, entitled "POINT-TO-POINT INTERNET

PROTOCOL".

2. Prior to May of 1995, I, with other named inventor(s), jointly conceived of the subject matter disclosed in the above-identified patent application.

3. A number of weeks after the conception of the inventive subject matter and various refinements to the inventive concepts, I helped form, and became a principal of, the Internet Telephone Company, a Florida Corporation having a place of business at One South Ocean Boulevard, Suite 305, Boca Raton, Florida 33432.

4. Following formation of the Internet Telephone Company, a detailed design specification entitled "Internet Telephone Company WebPhone Design", a copy of which is attached hereto as Exhibit B, was generated to memorialize a product implementation of the inventive concepts and to provide the basis from which coding and testing of a working embodiment of the inventive concepts continued diligently until the filing date of this patent application, September 25, 1995.

I hereby declare that all statements made herein of my own knowledge are true and that all statements made on information and belief are believed to be true; and further that these statements were made with the knowledge that willful false statements and the like so made are punishable by fine or imprisonment, or both, under Section 1001 of Title 18 of the United States Code, and that such willful false statements may jeopardize the validity of the application or any patent issued thereon.

  
Shane D. Mattaway

6/30/99  
Date

Residence: 826 Periwinkle Street, Boca Raton, FL 33486

Citizenship: United States

Post Office Address: 826 Periwinkle Street, Boca Raton, FL 33486

#31  
S. Ford  
2/8/00

ATTORNEY DOCKET NO. N0003/7000

IN THE UNITED STATES PATENT AND TRADEMARK OFFICE

Applicant: Glenn W. Hutton et al.  
Serial No.: 08/533,115  
Filed: September 25, 1995  
For: POINT-TO-POINT INTERNET PROTOCOL  
Examiner: M. H. Rinehart  
Art Unit: 2756



CERTIFICATE OF EXPRESS MAILING

"Express Mail" mailing label number: EL445948630US  
Date of Deposit: July 14, 1999

I hereby certify that the following Correspondence is being deposited with the United States Postal Service "Express Mail Post Office to Addressee" service pursuant to 37 C.F.R. §1.10 on the date indicated above in an envelope addressed to Commissioner of Patents and Trademarks, BOX ISSUE FEE, Washington, D.C. 20231.

*Frances M. Cunningham*  
Frances M. Cunningham

Assistant Commissioner for Patents  
Washington, D.C. 20231

DECLARATION OF PRIOR INVENTION IN THE UNITED STATES TO OVERCOME  
CITED PATENT UNDER 37 CFR 1.131

Sir/Madam:

This declaration is to establish completion of the invention in this application in the United States at a date prior to May 23, 1995, the effective date of prior art patent 5,581,552, cited by the Examiner. The undersigned Declarant was added as a named Inventor in the above-identified patent application. The Declarant's statements set forth below establishes conception of the invention prior to the effective date of the reference coupled with due diligence from prior to the effective date of reference to filing of the application. Exhibit B is submitted herewith to support the Declarant's statements. This Declaration is submitted prior to final rejection or payment of the issue fee in the application.

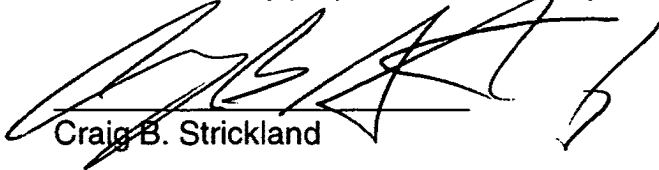
1. I am the named inventor in the United States Patent Application 08/533,115, filed September 25, 1995, entitled "POINT-TO-POINT INTERNET PROTOCOL".

2. Prior to May of 1995, I, with other named inventor(s), jointly conceived of the subject matter disclosed in the above-identified patent application.

3. A number of weeks after the conception of the inventive subject matter and various refinements to the inventive concepts, I helped form, and became a principal of, the Internet Telephone Company, a Florida Corporation having a place of business at One South Ocean Boulevard, Suite 305, Boca Raton, Florida 33432.

4. Following formation of the Internet Telephone Company, a detailed design specification entitled "Internet Telephone Company WebPhone Design", a copy of which is attached hereto as Exhibit B, was generated to memorialize a product implementation of the inventive concepts and to provide the basis from which coding and testing of a working embodiment of the inventive concepts continued diligently until the filing date of this patent application, September 25, 1995.

I hereby declare that all statements made herein of my own knowledge are true and that all statements made on information and belief are believed to be true; and further that these statements were made with the knowledge that willful false statements and the like so made are punishable by fine or imprisonment, or both, under Section 1001 of Title 18 of the United States Code, and that such willful false statements may jeopardize the validity of the application or any patent issued thereon.

  
Craig B. Strickland

06/14/99  
Date

Citizenship: Canada  
Residence Address: 5713 NW 65th Terrace, Tamarac, Florida  
Post Office Address: 5713 NW 65th Terrace, Tamarac, Florida

# Internet Telephone Company

*webPhone*<sup>TM</sup>  
**Design**

████████████████████

One South Ocean Blvd.  
Suite 305  
Boca Raton  
Florida  
33432  
Tel. 407.347.2447  
Fax. 407-347-2445

**THE INFORMATION CONTAINED HEREIN IS OF A HIGHLY  
CONFIDENTIAL AND PROPRIETARY NATURE AND IS NOT TO BE  
DISCLOSED TO ANYONE WITHOUT THE PRIOR WRITTEN CONSENT OF  
THE INTERNET TELEPHONE COMPANY.**

**EXHIBIT B**

### *webPhone* Structure and Function

The *webPhone* consists of a main window which looks and feels like a modern cellular flip phone and set of dialog boxes launched from the main window. See figure 1. The *webPhone* is controlled by clicking on objects (i.e. buttons, text and images) and dragging objects (i.e. lines, parties, messages, etc.).

The *webPhone* main window is 200x450 pixels closed and 200x590 pixels when the flip is opened. On a standard 640x480 display, when the user opens the flip door, the door detaches from the *webPhone* and is displayed on the side of the *webPhone*. This detached flip door is movable around the screen. When it is closed, it goes back onto the *webPhone* as before it was opened.

Buttons behave in one of two ways to the user. A button may be a *momentary* button which when pressed (left clicked on) gets pushed in then pops back out again or a button may be a toggle button which when pressed gets pushed in and stays in until pressed again (toggle buttons are either in a raised or depressed state). I will not make a joke here.

The objects comprising the *webPhone* main window are:

- display
- number pad
- line pad
- call function buttons
- phone function buttons
- audio control buttons and sliders

#### display

The display is 150x80 pixels and displays the following information:

#### *party name*

A text entry field using the READOUT truetype font. Text is 14 pixels high. The party name field can accommodate 20 to 25 characters on the display. If the user enters a name then presses [SND] to place the call and the user is not in the phone DIR, the *Directory Assistance* (Information) dialog will appear. If the user right clicks on the party name field, the *Update* phone DIR entry dialog will appear for that party if it exists thereby enabling the user to quickly modify the party's information.

When a call arrives, the caller's name will appear in the party name field as a caller ID feature.

**party IP address**

A text entry field using the READOUT truetype font. Text is 14 pixels high. To place a call to another user who has a known (fixed) IP address, the user enters the IP address in the party IP address field then presses [SND]. If the callee exists in the phone DIR and/or the call goes through, the callee's name will appear in the party name field (caller ID). If the IP address given is bad, the line status annunciator will say so.

**WebPhone status annunciators**

The 3rd line of the webPhone display is used to display iconic annunciators providing feedback to the user about the status of events taking place in the webPhone. The status annunciators are:

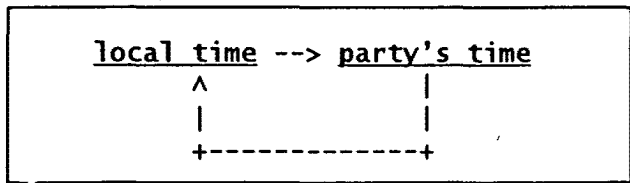
1. user is camped on one or more parties
2. default call forwarding is enabled (effects all parties with no specified call forwarding party)
3. call blocking is enabled (effects parties with call blocking enabled)
4. do not disturb is enabled
5. priority ringing is enabled (effects parties with priority ring enabled)
6. file transfer is occurring
7. voice mail transfer is occurring

**Line number annunciator**

Cycle through all lines by single clicking on the Line number annunciator (Li), the main LED or the line status annunciation text. The main LED color and line state annunciation text will change to reflect the state of the selected line. If the user is on a line with an active call, the Line number annunciator will return to reflect that line's status after a time out of 5 seconds. If no lines exist with active calls or no line is selected, the Line number annunciator will remain on the line which was last selected (i.e. no time out occurs to change the Line number annunciator back).

**Local time/party's time**

When there are no lines with active calls, the webPhone displays the current local time. When the user is on a line with an active call, the webPhone displays the remote party's time. By single clicking on the time, the user can cycle through the two different times as follows:



As the user changes lines, the time displayed will reflect the time format which was last selected for the selected line.



***new vmail msgs/total vmail msgs***

The *webPhone* displays the current number of new voice mail messages and the total number of voice mail messages as follows:

new / total

If the user single clicks on the *vmail msgs annunciator*, he/she can display the total number of voice mail messages. If the user single clicks on the *vmail msgs annunciator* again, it will revert back to display the current number of new voice mail messages. The *vmail msgs annunciator* will automatically revert back to display the number of new voice mail messages after 5 seconds.

***call duration***

The duration of the current call is displayed in mm:ss format. As the user cycles through the lines by clicking on the Line number annunciator, the call duration annunciator changes to reflect that line's call duration if any.

***main led***

This LED mirrors the LED of the currently selected line. The LED colors are specified in figure 48. The colors represent the state of the call on the selected line.

***line status text***

Informs the user as to the state of the currently selected line. See figure 48.

***list arrow***

Enables the user to pop down the list of parties on the selected conference call.

***Conference party list***

When a user selects a active line with a conference call, the name of the first party on the conference call is displayed in the *party name* field in the display along with the *list arrow* described above. Once the user presses the list arrow to obtain the conference party list, the user can view all the parties present on the conference call (even those parties added to the conference by another party on the conference call).

If the user right clicks on an unselected line with a conference call (i.e. while engaged on another active line), the conference party list is displayed (no need to press the list arrow) for viewing and manipulation of the parties as described below. In the event the user does nothing with the list for 5 seconds or another object is selected (e.g. another button is pressed), the display will revert back to displaying the information about the currently selected line.

The user may remove one or more parties from the conference call by selecting them in the conference party list and pressing [END]. The

user may also transfer one or more parties from the conference call by selecting them and dragging them to a free (IDLE) line. If the user is placed on hold by a party on the conference call, the only way the user may know this is to view the conference party list and check the face icon of the parties in the list.

#### ***Priority ring party list***

When the user enables priority ringing (depresses [PRI]) or right clicks anytime on [PRI], a list of parties who have priority ringing enabled will appear in the display. The user may disable priority ringing for one or more parties by selecting them in the list and pressing the |Delete| key. This removes the parties from the priority ring list and updates the effected parties' records in the phone directory by disabling priority ringing. The user may also disable priority ringing for one or more parties by updating their records directly in the phone directory. In the event the user does nothing with the list for 5 seconds or another object is selected (e.g. another button is pressed), the display will revert back to displaying the information about the currently selected line. If there are no parties with priority ringing enabled, pressing [PRI] does nothing.

#### ***Call blocking party list***

When the user enables call blocking (depresses [BLK]) or right clicks anytime on [BLK], a list of parties who have call blocking enabled will appear in the display. The user may disable call blocking for one or more parties by selecting them in the list and pressing the |Delete| key. This removes the parties from the call blocking list and updates the effected parties' records in the phone directory by disabling call blocking. The user may also disable call blocking for one or more parties by updating their records directly in the phone directory. In the event the user does nothing with the list for 5 seconds or another object is selected (e.g. another button is pressed), the display will revert back to displaying the information about the currently selected line. If there are no parties with call blocking enabled, pressing [BLK] does nothing.

In order to change the action to be performed when an inbound call arrives from a party with call blocking enabled (i.e. reject the call or give them to the answering machine), the user must update that party's record directly in the phone directory.

#### ***Camped on party list***

When the user right clicks on [CMP], the camped on party list appears in the display. The user may remove a camp on a party by selecting the party and pressing the |Delete| key. In the event the user does nothing with the list for 5 seconds or another object is selected (e.g. another button is pressed), the display will revert back to displaying the information about the currently selected line.

***speed dial info***

When a user right clicks on [0] or [1] or ... or [9], the name, alias, e-mail address and IP address (if known) of the party assigned to that speed dial position will appear in the display for 5 seconds or until another object is selected (e.g. another button is pressed), whichever comes first, then the display will revert back to displaying the information about the currently selected line.

***line info***

When a user right clicks on [L1], [L2], [L3] or [L4], the name, alias, e-mail address and IP address (if known) of the party on that line will appear in the display for 5 seconds or until another object is selected (e.g. another button is pressed), whichever comes first, then the display will revert back to displaying the information about the currently selected line.

***FWD party list***

When the user enables call forwarding (depresses [FWD]) or right clicks anytime on [FWD], a list of parties who have call forwarding enabled will appear in the display. The user may disable call forwarding for one or more parties by selecting them in the list and pressing the |Delete| key. This removes the parties from the call forwarding list and updates the effected parties' records in the phone directory by disabling call forwarding. The user may also disable call forwarding for one or more parties by updating their records directly in the phone directory. In the event the user does nothing with the list for 5 seconds or another object is selected (e.g. another button is pressed), the display will revert back to displaying the information about the currently selected line. If there are no parties with call forwarding enabled, pressing [FWD] does nothing.

In order to change a party's forwarding party (i.e. the party to be called) when an inbound call arrives from a party with call forwarding enabled, the user must update that party's record directly in the phone directory.

**number pad**

[0],[1],..[9] & [.]

The number buttons are 34x26 pixels. The number buttons may be used to enter a party's IP address. To erase an incorrect entry, the user must use the |Backspace| key on the keyboard. The number buttons also house the ten speed dial positions. The user may assign a party to one of the ten number buttons then initiate a speed dial by simply pressing [n] then [SND]. If the user right clicks on [n], the information about the party who is assigned to that speed dial position will be displayed.

**line pad**

[L1 o], [L2 o], [L3 o] & [L4 o]

The line buttons are 46x26 pixels. Line buttons are toggle buttons. Each line button has a letter and number indicating which line it is and a led which indicates the state of the call on that line (see figure

48). When a line has a call with more than one party (conference call), the line button will replace the letter L with the letter C indicating that it contains a conference call. When a line containing a conference call reverts back to having only one party on the call, the line button will replace the letter C with the letter L indicating that it now contains a regular call. The line buttons work like the buttons on your car radio, only one can be depressed at a time. When a line button is depressed it is pre-selected or the active line. Pressing a line button when no inbound calls exist pre-selects that line for the next inbound or outbound call (depresses the line button). Pressing a line button when an inbound call arrives on that line answers the call (depresses the line button). Pressing a line button when the line is IN USE places the call on hold (raises the line button). Pressing a line button when the line is on hold takes the line off hold (depresses the line button).

#### call function buttons

The call function buttons are 46x26 pixels.

#### **[RCL]**

Recall last number. [RCL] is a momentary button. Pressing [RCL] recalls the last party called by displaying the party's name, alias, e-mail address and IP address (if known), selecting a free line (if a line has not already been pre-selected) then automatically pressing [SND] to initiate the call. The user may also right click on [RCL] to view the party's name, alias, e-mail address and IP address (if known) in the display. If the user does not press [SND] to initiate the call within 5 seconds from right clicking on [RCL], the display will revert back to displaying the information about the currently selected line. If the user presses [RCL] while engaged on an active line, that line will be placed on hold just as if the user had pressed [HLD] or deselected that line. If no free lines are available, pressing [RCL] will do nothing, however right clicking on [RCL] will still display the information about the last party called.

#### **[END]**

Terminates a call. [END] is a momentary button. If the user presses [END] when no lines are active no action is performed.

#### **[SND]**

Places and answers a call. [SND] is a momentary button. If the user presses [SND] when there are no free lines available or no party name is present in the *party name* field in the display or no inbound calls exist then no action is performed. When a call is placed or answered, the status of the call is indicated in the display and in the led color on the line with the active call.

#### **[DND]**

Do not disturb. [DND] is a toggle button. When [DND] is depressed it instructs the *webPhone* not to disturb the user with inbound calls but to send all inbound calls to the answering machine. When do not disturb

is enabled, the display will annunciate the *do not disturb* icon. To turn off do not disturb, the user presses the depressed [DND] button.

#### [MUT]

Mute the conversation. [MUT] is a toggle button. When the user presses [MUT] the party on the call or all parties on a conference call can not hear the user (the microphone is effectively disabled). When mute is enabled, the *main led* and *line status* text in the display and the led color on the line button change to indicate that the call is muted. If the user presses [MUT] when no lines are selected or the selected line is in a state that cannot accept muting no action is performed. If a party mutes the call, the user has no indication of it. To unmute a call, the user presses the depressed [MUT] button.

#### [HLD]

Places the call on hold. [HLD] is a momentary button. When the user presses [HLD] the party on the call or all parties on a conference call are placed on hold (the microphone and speaker are effectively disabled). When hold is enabled, the *main led* and *line status* text in the display and the led color on the line button change to indicate that the call is on hold. If the user presses [HLD] when no lines are selected or the selected line is in a state that cannot accept muting no action is performed. If a party place the call on hold, the *main led* and *line status* text in the display and the led color on the line button change to indicate that the call has been placed on hold by the party. To take a call off hold, the user must press the line button of the holding call.

#### [CMP]

Camps on a party. [CMP] is a momentary button. Camping on a party serves to ensure that your call to that party will go through when the party is available (no longer busy or is back online). Think of it as a perpetual redial. When the user calls a party and the party is either BUSY or OFFLINE, the user may press [CMP] to camp on that party. To remove a camp on a party, the user must first display the camp list by right clicking on [CMP] then select the desired party and press the [delete] key.

#### [BLK]

Enables or disables call blocking. [BLK] is a toggle button. When call blocking is enabled (button is depressed) all inbound calls from parties who have call blocking enabled will be either rejected or given to the answering machine thereby not disturbing the user. Whether the call is rejected or given to the answering machine is specified in each party's record in the phone directory. If the call is rejected, the party will see REJECTED in their display.

#### [PRI]

Enables or disables priority ringing. [PRI] is a toggle button. When priority ringing is enabled (button is depressed) all inbound calls from parties who have priority ringing enabled will generate the priority

ring sound effect when the call arrives. Priority ringing is specified in each party's record in the phone directory.

**[FWD]**

Enables or disables call forwarding. [FWD] is a toggle button. When call forwarding is enabled (button is depressed) all inbound calls from parties who have call forwarding enabled will cause the *webPhone* to route the call to the designated call forwarding party as specified in the party's record in the phone directory. If the calling party has not been assigned a call forwarding party and call forwarding is enabled, the call will be routed to the default call forwarding party (assigned to [FWD] itself) if it exists. To assign a default call forwarding party the user drags the desired party from either the phone directory, line, camp list, speed dial position, etc. and drops it on [FWD].

**phone function buttons**

The phone function buttons are 46x26 pixels.

**[?]**

Help. [HLP] is a momentary button. Pressing [?] launches the *webPhone* manual - *wpman.exe*, an interactive, multimedia tutorial and help system. Puts the user right at the start of the manual.

**[CFG]**

Configure the *webPhone*. [CFG] is a momentary button. Pressing [CFG] launches the *configuration* dialog which enables the user to change the operating parameters of the *webPhone*. See figures 16 - 22.

**[DIR]**

Phone directory. [DIR] is a momentary button. Pressing [DIR] launches the *phone directory* dialog which enables the user to add, update, sort, view and delete parties and obtain directory assistance. See figures 7 - 10.

**[MSG]**

Voice mail messages. [MSG] is a momentary button. Pressing [MSG] launches the *voice mail messages* dialog which enables the user to view, sort, playback, delete, save and restore voice mail messages as well as create, playback, delete, save, restore custom outgoing messages and assign them to parties in the phone directory. See figures 4 - 6.

**[DAT]**

Data file transfer. [DAT] is a momentary button. Pressing [DAT] launches the *data file transfer* dialog which enables the user to monitor and control the progress of data file transferred to and from parties. This is also the dialog which enables users to retrieve their e-mail and create and send e-mail. See figures 13 - 15.

**[LOG]**

Call activity log. [LOG] is a momentary button. Pressing [LOG] launches the *call activity log* dialog which enables the user to view, sort, search for, print and delete call related events. The user may initiate a call to a party by double clicking on an event. See figures 11 - 12.

**X**

Exits the *webPhone*. If the user has one or more active calls, an information dialog (see figure 2.) will appear asking the user if he/she wishes to really exit and terminate the active calls.

**[ ]**

Minimizes or iconifies the *webPhone*. The *webPhone* icon will display the main LED color for the currently selected line.

***webPhone***

This is the *webPhone* about text button. When pressed the user obtains the *About* dialog. See figure 3.

**audio control buttons and sliders**

Control the recording and playback of voice mail and outgoing messages. Operate exactly like conventional audio tape deck controls.

***flip open/close***

Opens and closes the flip door

***progress bar***

Displays the extent of progress during playback and recording of audio. Recorded voice mail is limited to 2 minutes and recorded outgoing messages is limited to 30 seconds. These parameters are currently not configurable by the user (via [CFG]) - should we allow the user to change these parameters?

**[|<]**

Rewinds the tape to the beginning. [|<] is a momentary button.

**[>|]**

Fast forwards the tape to the end of the recording. [>|] is a momentary button.

**[x]**

Aborts recording or playback operation. [x] is a momentary button. If the user is recording a voice mail message and decides not to deliver it, s/he would press [x] to abort the recording then press [END] to terminate the call without sending voice mail.

[</]

Sound card speaker. [</] is a toggle button. Plays back audio on the sound card's speaker. [</] is only active (not dimmed) when the user has both a sound card and the IPC.

[>]

Plays back audio. [>] is a special type of momentary button. When pressed it starts playing audio and pops out to become the Pause button [||]. When [||] is pressed it pauses playback of the audio and pops out to become [>] again.

[.]

Stops playback of audio. [.] is a momentary button.

[o]

Records audio. [o] is a toggle button. When [o] is depressed the user is in record audio and can record voice mail or an outgoing message. To stop recording, the user may press [o] again or press [.]

#### ***SPK slider***

Speaker volume control. Enables the user to adjust the output volume of the audio received during conversation and playback of voice mail and outgoing messages. If the user does not have the IPC, the SPK control attenuates the sound card's speaker volume, If the user has the IPC, the SPK control attenuates the IPC's speaker volume and the sound card's speaker volume must be attenuated via the sound card's audio control panel.

#### ***MIC slider***

Microphone volume control. Enables the user to adjust the input volume of the audio recorded during conversation and recording of voice mail and outgoing messages. If the user does not have the IPC, the MIC control attenuates the sound card's microphone volume, If the user has the IPC, the SPK control attenuates the IPC's microphone volume and the sound card's microphone volume must be attenuated via the sound card's audio control panel.

The ITEL operator's have a [USR] button on their *webPhone* to acquire a user's *webphone.cfg* file during registration.

### **Implementation**

The *webPhone* will be developed under MS Windows using Borland C++ v.4.51. This compiler was chosen because of its extensive class library, the existence of C++ templates, OLE 2.0 support and familiarity by the programming staff.



### Platform

The *webPhone* will initially exist as a 16 bit version. A 32 bit version will be released later due to porting of socket and MCI code from 16 bit to 32 bit. Both versions will be capable of running on MS Windows 3.x and above. The 32 bit version will require the win32s subsystem to run on MS Windows 3.x (we will provide the user with the ability to obtain the win32s subsystem from the Intel Home Page).

The *webPhone* will use the w\_char character set to allow for future portability to foreign languages based upon 16 bit characters such as kanji, arabic, hebrew, etc.

The 32 bit version will employ threads where necessary to improve performance in the PhoneManager (PM) and its AudioEngines (AE).

### Architecture

The *webPhone* consists of a Graphic User Interface (GUI), a User Interface control (UI), a PhoneManager (PM) and an AudioEngine (AE). The GUI may be replaced by other GUI's such as X-Windows (UNIX), Presentation Manager (OS/2 Warp) and Macintosh without changing the UI, PM and AE to provide for fast porting to these other platforms. In addition, the *webPhone* can interface with multiple AEs to support a variety of audio compression and decompression algorithms (codecs) in software and hardware. For example, the *webPhone* interfaces with the software based GSM and TrueSpeech audio codecs via one AE (aesac.dll) and will interface with the ITEL phone card (IPC) via another AE (aeipc.dll). The *webPhone* will use the appropriate AE as required.

Refer to the System Architecture diagrams in figure 28 and the Software Architecture diagram in figure 29 for more details.

### Objects

The GUI, UI, PM and AE use a number of objects to house and manipulate the data associated with the operation of the *webPhone*.

The GUI objects control the look and feel of the graphic user interface controls seen by the user which constitute the *webPhone's* user interface. Some of the UI objects maintain and manage the many states of the *webPhone* and control the behavior of the graphic user interface controls. Refer to figures 40 - 46 for more details on GUI and UI objects.

The following objects are used primarily by UI and PM to manage the state of calls and tasks that are to be performed:

- line
- job
- party
- task

The AE only sees tasks. Refer to figure 47 for more details.

## User Interface (UI)

### The Separation of GUI and UI Logic

Each Phone Control has two objects associated with it. The GUI Part is windowing system specific and the UI part is generic. When the GUI Control's state is change by the user it first checks with the UI to make sure it's OK to make the change.

### UIControls and their parents

A UIControl is always a child of UICollection. When the UIControl's sibling, the GUIControl, asks the UIControl if its OK to make a change, and this change request is accepted, the GUIControl still must ask its parent if the change is valid. The parent UICollection may have its own parent, another UICollection, that it must ask if the new value is OK.

### The Grandparent of them all, the UIPhone

The UIPhone is a UICollection. It has final say in all changes. It also must tell its children when the Phone Manager changes the phone state. It also creates jobs for the phone manager based on user actions. The UIPhone contains the following, the UILine Collection, all UIPopup collections, the MSG, DIR, LOG, CFG, DAT, PRI, BLK, and FWD buttons.

### UILine

The UILine Collection contains all the collections and phone buttons that relate to the changes in the state of the line. Specifically, these are the four line buttons (e.g. L1, L2, L3, and L4), the RCL button, the HLD button, the MUT button, and the UICall Collection. The UIPhone is the parent of UILine.

### UICall

The UICall Collection contains all the buttons related to calls. Specifically these are the number buttons, 0 - 9, ., the SND button, and the CMP button. The UICall's parent is the UILine.

### Windows Drag Drop

The DragObject function implements the server component of the drag and drop. A drag and drop server calls this function in response to a user initiated drag. Below is the function proto-type.

```

DWORD FAR PASCAL DragObject (
    HWND          Scope,           // Scope of drag
    HWND          Source,         // Window handle initiating Drag
    WORD          Type,           // Dragged object type
    WORD          OfStruct,       // Handle to OFSTRUCT (not required)
    NPSTR         Data,           // Near point to drop data
    HCURSOR       Cursor,        // Handle to cursor
);

```

The Scope parameter limits the windows that can receive the drop. Only that window and its children will get the drop request. By setting it to GetDeskTopWindow(), any window can get the drop. The Source parameter is the server's window handle. The Type is the type of drag. Windows has four standard drag types (See table below). A drag is limited to a single application unless the Type parameter is or'ed with DRAGOBJ\_EXTERNAL (0x0001).

If the object being dragged is a single file a OFSTRUCT global memory handle may be specified. But is not required, and may be set to NULL. Data points to a string containing the object data. Cursor is a cursor handle that shows when the mouse is over a window that will accept this type of drop.

As the user drags the object the function sends WM\_QUERYDROPBJECT to the window under the mouse. As long as the underlying window returns 0, the no entry cursor is displayed. If 1 is returned the cursor specified in the cursor parameter is displayed.

If the mouse left button is released over a window that will not accept the drop, the function returns 0, otherwise it returns non-zero. At this point the server builds a DROPINFO struct in global memory and sends it as the LPARAM in a WM\_DROPFILES message.

```
typedef struct {
    WORD DataOffset;    // Offset of the character data
    WORD x;             // mouse x position of drop
    WORD y;             // mouse y position of drop
    BOOL InClient;     // True if in client area of window
    char Data[n]        // Drop string data
} DROPINFO, FAR *LPDROPINFO;
```

### WebPhone Drag Drop

The WebPhone drag and drop will use the standard windows drag and drop by adding some of its own object types (See table below). Each UIControl and GUIControl will have two member functions added to them (e.g. SetDragType(uint Type = 0) and AcceptDropTypes(uint Count = 0, uint\* Types = NULL) ). The SetDragType call will set the type of drag that the control will do if the mouse is moved out of the controls window with the left mouse button down. If the type is 0 no drags will happen. The AcceptDropTypes function will set the types of drags the control will accept. If either Count or Types is zero no drops will be accepted. (NOTE: since messages an ogms can be dragged to the file manager this drag will be of type DRAGOBJ\_DATA)

Windows Standard Drag Types	Value	Data
DRAGOBJ_PROGRAM	0x0001	File Name
DRAGOBJ_DATA	0x0002	File Name
DRAGOBJ_DIRECTORY	0x0003	Directory Names

DRAGOBJ\_MULTIPLE

0x0004

File and Directory  
Names Separated by  
spaces

**WebPhone Drag Types**

DRAGOBJ\_CALL

0x0005

String with Job Pointer

DRAGOBJ\_CONFERENCECALL

0x0006

String with Job Pointer

DRAGOBJ\_DIRENTRY

0x0007

String with key for  
entry into phonedir.db

### PhoneManager (PM)

The PM is a state machine. It consists of an array of pointers to functions and states which makes up a state-event table. When an event occurs (caused by the mouse, keyboard, mic, speaker or socket), it is up to the UI to determine if the event requires the attention of the PM. The PM is not notified of those events which only effect the GUI (e.g. user presses [DIR] to open the Phone Directory dialog). When the PM is to be notified of a call related event, the UI makes the following calls to PM where *l* = current lineID of call:

```
// trigger PM to perform action based upon event and current state
(*PhoneManager[line[l]]->job.state)[event].fxn)(arg1,arg2,arg3);
```

```
// obtain new job state from PM
line[l]->job.state = PhoneManager[line[l]->job.state][event].newstate;
```

When the PM is to be notified of a non-call related event, the UI makes the following calls to PM:

```
// trigger PM to perform action based upon event and current job state
(*PhoneManager[job.state][event].fxn)(arg1,arg2,arg3);
```

```
// obtain new job state from PM
job.state = PhoneManager[line[l]->job.state][event].newstate;
```

Refer to the UI Triggered PM Events diagram in figure 53 for more details.

### AudioEngine (AE)

#### Crippled WebPhone

Users may obtain a crippled version of the *webPhone* for trial use, at no cost, from the ITEL Home Page. The *webPhone* will become uncrippled once the user registers the *webPhone* (i.e. pays the \$49.95 or \$149.95). The *webPhone* will be crippled as follows:

#### Limited Functionality

The following buttons on the *webPhone* are active, the remainder are dimmed and inactive:

L1, L2, LOG, MSG, DIR, MUT, HLD, RCL, END, SND & CFG
--

Limited Talk Time

Allow only 60 seconds of conversation per call. The 60 seconds begins once the call is in the INUSE state. After the 60 seconds has elapsed, the call is disconnected and the calling user's webPhone will play the sound file *cnvtime.wav* which says in a female operator's voice something like this: "You must register your webphone for unlimited talk time".

Limited Phone Directory

Allow only (2) phone directory entries plus the ITEL phone directory entry. When the user attempts to add a forth phone directory entry the webPhone will play the sound file *cdiradd.wav* which says in a female operator's voice something like this: "You must register your webphone to have unlimited phone directory entries".

Limited Voice Mail

Allow only (1) functional voice mail message at any given time and restrict the message duration to 15 seconds for both incomming and outgoing messages. All other voice mail messages received will be displayed as dimmed audio cassette icons in the Voice Mail Messages dialog. This will enable users to still see the voice mail they have received in leu of the limitation. In the event the user attempts to play back a dimmed voice mail message, the webPhone will play the sound file *cvmlmsg.wav* which says in a female operator's voice something like this: "You must register your webphone for unlimited voice mail". The user may only delete dimmed voice mail messages and not copy or move them to a directory in the MS Window's file Manager.

Limited Conference Calling

The user is permitted only 1 conference call with a maximum of 2 remote parties on the conference. In the event the user attempts to add a third party to the conference, the webPhone will play the sound file *ccnfadd.wav* which says in a female operator's voice something like this: "You must register your webphone for unrestricted conferencing". If a remote party with a registered webPhone adds a third party to the conference (relative to the local user with the crippled webPhone), the user will not be allowed to converse with that party yet will be able to see that party in the conference list (a teaser).

Limited Speed Dial Position

Allows the user the first 2 speed dial positions: [1] and [2]. When the user attempts to add a party to any of the other 8 speed dial positions the webPhone will play the sound file *cspdadd.wav* which says in a female operator's voice something like this: "You must register your webphone for unrestricted speed dialing".

See Speed

will reject when

### Limited Activity Logging

Allows the user to view a maximum of 3 events in the Call Activity dialog. The call activity log activity.log will still retain the logged call activity. The user will still be able to see the total number of events that were logged (a teaser).

### Limited Outgoing Messages

Allows the user only ~~one~~ <sup>one</sup> custom OGM. When the user attempts to add a second OGM the webPhone will play the sound file *cogmadd.wav* which says in a female operator's voice something like this: "You must register your webphone to define unlimited outgoing messages".

## WebPhone Acquisition and Setup

### When the webPhone is obtained from ITEL's Home Page:

The ITEL Home Page will enable the user to acquire the crippled version of the webPhone via ftp. All the installation files will be placed in a self extracting ZIP file named *itelwp10.exe*. The user will obtain the *itelwp10.exe* file and a *readme.txt* file which explains how to extract the installation files from the zip file into a temporary installation directory. Once extracted into a temporary directory, the *wpsetup.exe* file can be executed from MS Windows to install the webPhone.

### When the webPhone is obtained from the purchase of the ITEL phone card:

The webPhone software will probably reside on two 3.5" 1.44MB floppy disks. The user will insert the floppy disk labeled "installation disk" and execute *wpsetup.exe* from MS Windows to install the webPhone.

### Installation

InstallShield by Stirling will be used to develop the installation file *setup.exe* and create the installation image (to be zipped up into *itelwp10.exe* or placed on floppy diskettes). *Wpsetup.exe* will perform the following actions:

1. present the user with an attractive installation screen in a window
2. check for adequate disk space. If not enough disk space, inform user and exit setup.
3. present the user with a dialog box allowing the user to select:
  - complete installation
  - custom installation
  - uninstall
  - exit

Note:  are radio buttons.

The following pertains to both complete and custom installation (if "install the *webPhone*" was selected):

4. search for previous version. If not found, say nothing to the user and continue. If found, ask the user if he/she would like to update or re-install. If update is selected, skip steps 6 thru 10 below (unless new or updated db files are required). If re-install is selected, continue with step 5 below.
5. prompt the user for a desired installation directory
6. prompt the user to complete the user information form thereby supplying his/her name, addr, phone, etc. and his/her e-mail address and IP address if known.
7. create the *webPhone* directory structure and install the files.
8. prompt the user to specify which existing program manager group or the name of a new group to place the *webphone.exe*, *wpvmpplay.exe*, *wpman.exe* and the *readme.wri* icons into.
9. initialize database files
10. initialize counters in *webphone.cfg*
11. auto-recognize the ITEL phone card, if any, and test for operability; inform the user of the results and update *webphone.cfg* indicating the ITEL phone card is present and its version information. This is also performed every time *webphone.exe* is executed except the user is not notified of the results.
12. auto-recognize the user's sound card, if any, and test for compatibility; inform the user of the results and update *webphone.cfg* indicating a sound card is present and its name. This is also performed every time *webphone.exe* is executed except the user is not notified of the results.
13. associate audio files *\*.wpm* with *wpvmpplay.exe* in *win.ini* (may not be necessary in Win95)
14. display "How to order" information
15. ask user if he/she would like to run the tutorial (*wpman.exe*).
16. inform the user installation was complete.

If custom installation was selected, the user would get the following dialog:

- install the *webPhone*
- define user information
- install database files >>

Note:  are check boxes and >> is a "more" button

If the user selects "install the *webPhone*", he/she will follow steps 4 thru 16 above.

If the user selects "define user information", he/she will be prompted to complete the user information dialog (step 6. above) which will update *webphone.cfg*.

If the user selects "install database files", he/she will get another dialog prompting the user to select which database files to install:



- configuration database - webphone.cfg
- phone directory - phonedir.db
- voice mail messages directory - messages.dir
- file transfer directory - files.dir
- outgoing messages directory - ogm.dir
- call activity log - activity.log

If any of the database tables are selected, those database tables will be re-created and initialized. In the event the "configuration database - webphone.cfg" is selected, the user will be prompted to enter his/her user information as if he/she had selected "define user information" in the custom installation dialog and steps 10-12 above will be performed.

## E-mail Communication Protocol

### Incoming messages

The following e-mail messages are transmitted to a remote user's Post Office Protocol (POP) server via the Simple Mail Transport Protocol (SMTP) using MIME by the PhoneManager (PM):

- Connect Request
- Camp Request
- Voice Mail
- File Transfer
- E-mail

### Outgoing messages

The following e-mail messages are received from the local user's POP server via the POP protocol using MIME by the PM:

- Connect Request
- Camp Request
- Voice Mail
- File Transfer
- E-mail
- Registration

### Message structure

The e-mail messages are identified by unique subject information as described below:

**!TEL(L), ~~TYPE~~ SID, EMAILADDR, IPADDR, PartNum, Total Parts**  
**NETSPEAK**

where

SID is the unique session identifier as an ulong in hex: 00000000-FFFFFFFF

EMAILADDR is the e-mail address of the sender: username@host.domain.org

IPADDR is the IP address of the sender as a char string: 198.98.127.9

PartNum is the file number of Total Parts

Total Parts is number of emails for this type (1 of 10)

Message	L	TYPE
Connect Request	C	CALL
Camp Request	P	CAMPCALL
Voice Mail	V	VMAIL
File Transfer	F	FILEXFR
E-mail	M	EMAIL
Webphone Registration	R	REGISTRATION

Those messages which contain attached data (VMAIL, FILEXFR, EMAIL and REGISTRATION) use the MIME protocol. VMAIL is in compressed wpm format (either GSM or Truespeech compressed file detectable by a magic cookie present in the file header).

\* EMAIL may or may not contain attached data files

Note: the subject does not contain any non-printable ascii characters.

All messages except EMAIL contain a text message in the message body in case the user's e-mail program (e.g. Eudora) captures the ITEL messages.

The text for a CALL or CAMPCALL message may say something like this:

"You have a webPhone call from name at emailAddr. If you do not have a webPhone and wish to talk to name, contact the Internet Telephone Company at http://www.itel.com or call 800-NNN-ITEL."

where name and emailAddr are the full name and email address of the caller.

The text for a VMAIL message may say something like this:

"You have webPhone voice mail from name at emailAddr. If you do not have a webPhone and wish to listen to your voice mail from name, contact the Internet Telephone Company at http://www.itel.com or call 800-NNN-ITEL."

The text for a REGISTRATION message may say something like this:

"Attached is your webPhone registration file. Please save it as "webphone.reg" in your webphone directory to enable your webPhone. If you should encounter a problem with your webPhone, e-mail us at info@itel.com or call 800-NNN-ITEL. Thank you for purchasing the ITEL webPhone."

The text for a FILEXFR message may say something like this:

“Attached is one or more files sent to you by name at emailAddr via their webPhone. If you do not have a webPhone and wish to easily perform file transfer over the net not to mention converse in real time, send and receive voice mail, etc., contact the Internet Telephone Company at <http://www.itel.com> or call 800-NNN-ITEL.”

## File System

Figure 32 represents the webPhone file system as it would exist on a user's hard disk. The following files are present:

### in webphone\

readme.wri (MS Windows Write file describing how to install, list of files...)

webphone.exe (the webPhone)

wpvmlplay.exe (webphone vmail player associated with \*.wpm files)

wpman.exe (authorware based tutorial, manual and help system)

webphone.reg (exists for sound card version after user registers)

wpsetup.exe (webphone installation and setup program)

activity.log (call activity log)

phonedir.db (phone directory database)

wpnet.dll (internet communications library)

wpaesac.dll (audio engine for audio card based webphone)

wpaepc.dll (audio engine for ITEL phone card)

wpsac.dll (software based audio codec library - GSM and Truespeech)

wpipc.dll (ITEL phone card interface library - API)

ctpwin.dll (c-tree plus windows database interface library)

\*.vbx (if any - we will try not to use any)

### in webphone\vmail

messages.dir (directory of resident messages)

### in webphone\vmail\in

XXXXXXXX.wpm (received compressed voice mail message files, X = 0-9)

### in webphone\vmail\out

XXXXXXXX.wpm (sent compressed voice mail message files, X = 0-9)

### in webphone\ogm

ogm.dir (directory of resident outgoing messages)

wpogm.wav (default outgoing message)

XXXXXXXX.wav (outgoing voice message files, X = 0-9)

### in webphone\files

files.dir (directory of resident messages)

### in webphone\files\in

\*.\* (received e-mail, executable, text, data and winapp files)

### in webphone\files\out

\*.\* (transmitted e-mail, executable, text, data and winapp files)

in `webphone\sounds`

`noanswer.wav` ("the party does not answer")  
`offline.wav` ("the party is not online")  
`busy.wav` ("I'm sorry, the party is busy, please try again later")  
`ringout.wav` (standard ring when calling)  
`ringin.wav` (standard ring when receiving a call)  
`badaddr.wav` ("this is a bad address")  
`error.wav` (sound of machinery breaking)  
`numpad.wav` (button press sound for 0,1,2,...,9 and .)  
`hold.wav` ("holding, please stand by")  
`priority.wav` (standard priority ring sound)  
`campack.wav` (special ring when party is available to call)

## Voice Mail

The user may record and send voice mail to remote users when the remote user's answering machine answers or calls are not completed because of the remote user being offline or busy.

### Remote user is offline

When a user gets an OFFLINE from a remote *webPhone*, the user may record a voice mail message which will be e-mailed {VMAIL} to the remote *webPhone*. The voice mail file name, in order to be unique, is defined by the remote *webPhone* upon receipt of the {VMAIL}. Refer to the E-mail Communications Protocol above for details.

Upon receipt of {VMAIL}, the *webPhone* will extract the compressed audio portion of the voice mail message and save it to the `webphone\vmail\in` directory with the following name:

XXXXXXXXX.wpm      where X = {0,1,2,...9 }

The filename will be created from the `vmailName` field in `webphone.cfg`.

This nomenclature allows for 100 million unique file names before the sequence repeats itself.

Once received, the *webPhone* will update the `messages.dir` file in the `..\webphone\vmail` directory. Refer to the `messages.dir` database schema in figures 33 - 36 for more details.

### Remote user is busy

When a user gets a BUSY from a remote *webPhone*, the user may record and transmit a voice mail message to the remote *webPhone*. This transmission takes the form of multiple <Vmail> packets and a terminating <VmailEnd> packet. During the receipt of the voice mail, the remote *webPhone* is saving the voice mail message to a voice mail file named `XXXXXXXXX.wpm` in the remote user's `webphone\vmail\in` directory.

Remote user's answering machine answers

When a user gets an ANSWERING MACHINE from a remote *webPhone*, the remote *webPhone*'s answering machine answered the call and is playing an outgoing message to the user. Once the remote user's OGM is complete, the user may record and transmit a voice mail message to the remote *webPhone* as described above for the remote user busy condition.

Recording voice mail

When it is OK to record a voice mail message, the user's *webPhone* will activate the audio playback and record controls in the flip door of the phone. If the flip door is closed, it will be automatically opened. Once activated, the user operates the controls like a normal audio tape deck to record and playback the voice mail message. When the user is ready to transmit the voice mail message, he/she presses [END] to end the call. If the user wishes not to send a voice mail message, he/she presses [END] without having recorded a voice mail message. If the user has begun to record a voice mail message and decides he/she does not wish to send it, the user would press the cancel button [X] in the audio controls to abort the voice mail recording then press [END] to end the call.

What the user sees when voice mail arrives

The *webPhone* will increment the number of new messages in the display. If the Voice Mail Messages dialog is up, the new message will be placed at the top of the list.

## Copy Protection

If a user has the ITEL phone card

the *webPhone* will detect and use the card without using the *webphone.reg* file as a copy protection mechanism.

If the user does not have the ITEL phone card

when the user registers (i.e. pays \$49.95), we will e-mail the *webphone.reg* file to the user as the special e-mail message REGISTRATION. The *webphone.reg* file contains that user's DES encrypted e-mail address. The *webPhone* will receive the REGISTRATION message and place the attached *webphone.reg* file in the *webphone* directory. When the registered user starts their *webPhone*, it will read the *webphone.reg* file and decrypt the user's e-mail address (This means the key is hardcoded into the *webPhone*). It will then compare the decrypted e-mail address with that in the user's *webphone.cfg* file. If the two e-mail addresses match, the *webPhone* will operate uncrippled, otherwise, it will notify the user of the problem, suggest the solution and exit.

In the event the user changes his/her e-mail address or IP address, via User Info ala [CFG] they will be required to a change of address to us (by calling ITEL on their *webPhone*, going to the ITEL Home Page or by e-mail to info@itel.com) in order to obtain a new *webphone.reg* file. A registered user with more than 2 change of address applications is suspect of copying the software.

Note: it makes no sense for a registered user to copy the software and give the it to another user since the recipient will not be able to receive phone calls or voice mail at their actual e-mail address. If the recipient changes the registered user's e-mail address and optional IP address, the *webPhone* will operate in the crippled state since the e-mail address encrypted in *webphone.reg* will not match that in *webphone.cfg*.

### Configuration [CFG]

The Configuration dialog, obtained when the user pressed the [CFG] button, has the following 7 tabbed sections covering areas in which parameters are defined by the user to control the operation of the *webPhone*. Refer to figures i - i.

1. User Information
2. Phone
3. Answering Machine
4. Phone Directory
5. Sound Effects
6. Audio Card
7. Activity Log

All the configuration information is stored in the *webphone.cfg* file located in the *webphone* directory.

## ITEL Home Page

The ITEL Home Page consists of

- a brief description of the Internet Telephone Company
- a succinct description of our product's features and how it is vastly superior to Vocaltec's iphone and is less expensive.
- a graphical (e.g. image of *webphone*) and textual link to a detailed description of the *webPhone's* features
- a graphical link and textual link to FTP the crippled *webPhone* to the user
- a graphical and textual link to the *order* form
- a graphical and textual link to the *change of address* form
- a graphical and textual link to *directory assistance* form
- a link to WEBPALS description, registration and inquiry form

### Information (Directory Assistance)

Enables users to query the master phone directory for other user's e-mail and IP addresses (if known). This will initially be a free service.

### Change of Address

Enables the user to enter their old e-mail address and IP address (if known) then prompts the user to enter their new e-mail address and IP address (if known). If the user has already had less than two prior change of address requests, ITEL will email the user his/her new *webphone.reg* file. If the user has already had two change of address requests, ITEL will email the user an explanation request form which must be completed and emailed back to ITEL. If the explanation is valid, ITEL will email the user his/her new *webphone.reg* file. If the explanation is suspect, ITEL will inform the user it is against the law to copy licensed software and he/she will need to purchase another *webPhone*.

## WebPhone Protocol (WPP) Packet Definitions

Packet #	Packet	Packet Type	Direction	Data
100	Invalid	WPP_INVALID	← →	WPP_INVALID
101	Online Req	WPP_ONLINEREQ	→	WPP_ONLINEREQ, sid, version, emailAddr, IPAddr, onlineState
102	OnlineACK	WPP_ONLINEACK	←	WPP_ONLINEACK, sid, onlineStatus
103	Offline	WPP_OFFLINE	← →	WPP_OFFLINE, sid
104	Hello	WPP_HELLO	← →	WPP_HELLO, sid, version
105	Connect Req	WPP_CONNECTREQ	→	WPP_CONNECTREQ, sid, version, callType, partyEmailAddr, emailAddr, IPAddr, connectState
106	Connect ACK	WPP_CONNECTACK	← →	WPP_CONNECTACK, sid, connectStatus, partyIPAddr
107	Call	WPP_CALL	← →	WPP_CALL, sid, version, emailAddr, IPAddr, userInfo
108	CallACK	WPP_CALLACK	← →	WPP_CALLACK, sid, version, emailAddr, IPAddr, userInfo
109	CnfCall	WPP_CNFCALL	← →	WPP_CNFCALL, sid, version, emailAddr, IPAddr, userInfo
110	CnfCallACK	WPP_CNFCALLACK	← →	WPP_CNFCALLACK, sid, version
111	Answer	WPP_ANSWER	← →	WPP_ANSWER, sid
112	Busy	WPP_BUSY	← →	WPP_BUSY, sid
113	AnsMachine	WPP_ANSMACH	← →	WPP_ANSMACH, sid, state
114	End	WPP_END	← →	WPP_END, sid
115	Hold	WPP_HOLD	← →	WPP_HOLD, sid, (ON   OFF)
116	Reject	WPP_REJECT	← →	WPP_REJECT, sid
117	Camp	WPP_CAMP	← →	WPP_CAMP, sid
118	CampACK	WPP_CAMPACK	← →	WPP_CAMPACK, sid
119	Audio	WPP_AUDIO	← →	WPP_AUDIO, sid, audioType, silence, length, audioData
120	Vmail	WPP_VMAIL	← →	WPP_AUDIO, sid, audioType, silence, length, audioData
121	VmailEnd	WPP_VMAILEND	← →	WPP_VMAILEND, sid
122	OgmEnd	WPP_OGMEND	← →	WPP_OGMEND, sid
123	CnfAdd	WPP_CNFAADD	← →	WPP_CNFAADD, sid, partyEmailAddr, partyIPAddr, partInfo
124	CnfDrop	WPP_CNFDROP	← →	WPP_CNFDROP, sid
125	FileXmtReq	WPP_FILEXMTREQ	← →	WPP_FILEXMTREQ, sid, fileType, fileName, fileSize



## WebPhone Protocol (WPP) Packet Definitions (con't)

Packet #	Packet	Packet Type	Direction	Data
126	FileXmtAck	WPP_FILEXMTACK	←→	WPP_FILEXMTACK, sid
127	File	WPP_FILE	←→	WPP_FILE, sid, length, fileData
128	FileXmtEnd	WPP_FILEXMTEND	←→	WPP_FILEXMTEND, sid
129	FileXmtAbort	WPP_FILEXMTABORT	←→	WPP_FILEXMTABORT, sid
130	InfoReq	WPP_INFOREQ	→	WPP_INFOREQ, sid, query
131	InfoACK	WPP_INFOACK	←	WPP_INFOACK, sid, nparties
132	Info	WPP_INFO	←	WPP_INFO, sid, partyInfo
133	InfoAbort	WPP_INFOABORT	→	WPP_INFOABORT, sid
134	UserInfoReq	WPP_USRINFOREQ	←	WPP_USRINFOREQ, sid
135	UserInfo	WPP_USRINFO	→	WPP_USRINFO, sid, version, userInfo
136	WBImageStart	WPP_WBIMAGESTART	←	WPP_WBIMAGESTART, sid, fileSize, imageType
137	WBImage	WPP_WBIMAGE	←	WPP_WBIMAGE, sid, length, imageData
138	WBImageEnd	WPP_WBIMAGEEND	←	WPP_WBIMAGEEND, sid
139	WBAudioStart	WPP_WBAUDIOSTART	←	WPP_WBAUDIOSTART, sid, fileSize, audioType
140	WBAudio	WPP_WBAUDIO	←	WPP_WBAUDIO, sid, length, audioData
141	WBAudioEnd	WPP_WBAUDIOEND	←	WPP_WBAUDIOEND, sid
142	Registration	WPP_REG	←	WPP_REG, sid, EEmailAddr
143	Caller OK	WPP_CALLEROK	←	WPP_CALLEROK, sid, version, emailAddr
144	Caller ACK	WPP_CALLERACK	←	WPP_CALLERACK, sid, callerStatus
145	Key Pad	WPP_KEYPAD	←	WPP_KEYPAD, sid, (ON   OFF)
146	Key	WPP_KEY	→	WPP_KEY, sid, ascii character

## WebPhone Protocol (WPP) Packet Data Definitions

Element	Data Type	Comment
WPP_*	unsigned char	WPP_ message identifier
sid	unsigned long	session id unique per call
version	unsigned short (3)	version of the webphone (capability, protocol, vendor)
emailAddr	varchar(90)	email address of caller
IPAddr	varchar(80)	IP Address
onlineState	unsigned char	bit 0 (ACTIVE   INACTIVE) bit 1 (Merchant Phone) bit 2 (Connection Server) bit 3 (webboard disabled) bit 4 Not Used bit 5 Not Used bit 6 Not Used bit 7 Not Used
callType	unsigned char	call type 0: EMAIL   1: IPCALL
partyEmailAddr	varchar(90)	email address of person to call
connectStatus	unsigned char	0: NOWEBPHONE 1: ONLINE 2: OFFLINE 3: RECONNECT 4: PERM_RECONNECT
partyIPAddr	varchar(80)	IP Address of person to call
userInfo	varchar(120)	firstName, LastName, alias, emailAddr, street, apt, city, state, country, postalCode, phone, fax, company
audioType	unsigned char	audio compress type 0:GSM 1: TRUESPEECH

## WebPhone Protocol (WPP) Packet Data Definitions (con't)

Element	Data Type	Comment
length	unsigned short	length of audio or data in bytes
audioData	512 Bytes	compressed audio data
fileType	unsigned char	file type 0:DATA 1:EMAIL 2:TEXT 3:BINARY
fileName	varchar(13)	name of file to be transmitted. 8.3 nomenclature
fileSize	unsigned long	size of file to be transmitted in bytes
fileData	variable	file data
query	varchar(120)	firstName, lastName, company, city, state, country
nparties	unsigned long	number of parties or query records being sent
size	unsigned long	size of file (IMAGE or AUDIO) to be sent
imageType	unsigned char	image type 0: GIF 1: JPG
imageData	512 Bytes	image data
eemailAddr	varchar(90)	encrypted email Address
onlineStatus	unsigned char	0 OK -1 Error
callerStatus	unsigned char	0 is unpaid 1 if paid
onlineState	unsigned char	bit 0 webboard disabled bit 1 Not Used bit 2 Not Used bit 3 Not Used bit 4 Not Used bit 5 Not Used bit 6 Not Used bit 7 Not Used

### Customer Table

Field	Data Type	Ctree Type	Index	Offset	Comments
delflag	int	COUNT		0	Used by Database
id	ulong	LONG	Y	2	Unique ID Sequence
activated	char	char	Y	6	0 = NO, 1 = YES
activationDate	ulong	LONG		7	Secs since 00:00 GMT Jan 1, 1970
version capability	ushort	COUNT		11	Version of the Webphone
version protocol	ushort	COUNT		13	
version vendor	ushort	COUNT		15	
paid	char	char		17	0 = NO, 1 = YES
prePaidCode	varchar(16)	TEXT[16]	Y	18	
firstName	varchar(10)	TEXT[10]	Y	34	
lastName	varchar(25)	TEXT[25]	Y	44	
alias	varchar(20)	TEXT[20]		69	
emailAddr	varchar(90)	TEXT[90]	Y	89	
IPAddr	varchar(80)	TEXT[80]		179	0.0.0.0 if not known
street	varchar(50)	TEXT[50]		259	
apt	varchar(5)	TEXT[5]		309	
city	varchar(20)	TEXT[20]	Y	314	
state	varchar(20)	TEXT[20]	Y	334	
country	varchar(20)	TEXT[20]	Y	354	
postalCode	varchar(20)	TEXT[20]		374	
phone	varchar(25)	TEXT[25]		394	
fax	varchar(25)	TEXT[25]		419	
company	varchar(25)	TEXT[25]	Y	444	Company Name
addrChanges	char	char		469	Number of address changes
addrChangeDate	ulong	LONG		470	Secs since 00:00 GMT Jan 1, 1970
publish	char	char		474	0 = NO, 1 = YES
accessDate	ulong	LONG		475	Secs since 00:00 GMT Jan 1, 1970
accessCount	ulong	LONG		479	# of times user has started Webphone
callCount	ulong	LONG		483	Total number of outbound calls customer has made

Total Record Size = 487

### Online Table

Field	Data Type	Ctree Type	Index	Offset	Comments
delflag	int	COUNT		0	Used by Database
emailAddr	varchar(90)	TEXT[90]	Y	2	
IPAddr	varchar(80)	TEXT[80]	Y	92	
flags	char	char		172	
onlineDate	ulong	LONG		174	

Total Record Size = 178

### WebBoard Table

Field	Data Type	Ctree Type	Index	Offset	Comments
delflag	int	COUNT		0	Used by Database
id	ulong	LONG	Y	2	Unique ID Sequence
image	varchar(8)	TEXT[8]		6	Filename of image file
imageType	char	char		14	.GIF =0, JPG = 1
audio	varchar(8)	TEXT[8]		15	Filename of TSP encoded .WAV file
audioType	char	char		23	GSM = 0, TRUESPEECH = 1
hits	ulong	LONG		24	Number of accrued hits

Total Record Size = 28

### Weboard Config Table

Field	Data Type	Ctree Type	Index	Offset	Comments
delflag	int	COUNT		0	Used by Database
count	ulong	LONG	Y	2	Number of WebBoards

Total Record Size = 6

### Advertiser Table

Field	Data Type	Ctree Type	Index	Offset	Comments
delflag	int	COUNT		0	Used by ctree
id	ulong	LONG	Y	2	Unique ID
weboardID	ulong	LONG		6	Link to WebBoard record
name	varchar(50)	TEXT[50]		10	Company's name
url	varchar(80)	TEXT[80]		60	URL to Home Page
street	varchar(50)	TEXT[50]		140	
apt	varchar(5)	TEXT[5]		190	
city	varchar(20)	TEXT[20]		195	
state	varchar(20)	TEXT[20]		215	
country	varchar(20)	TEXT[20]		235	
postalCode	varchar(20)	TEXT[20]		255	
phone	varchar(25)	TEXT[25]		275	
fax	varchar(25)	TEXT[25]		300	
contact	varchar(35)	TEXT[35]		325	Name of contact

Total Record Size = 360

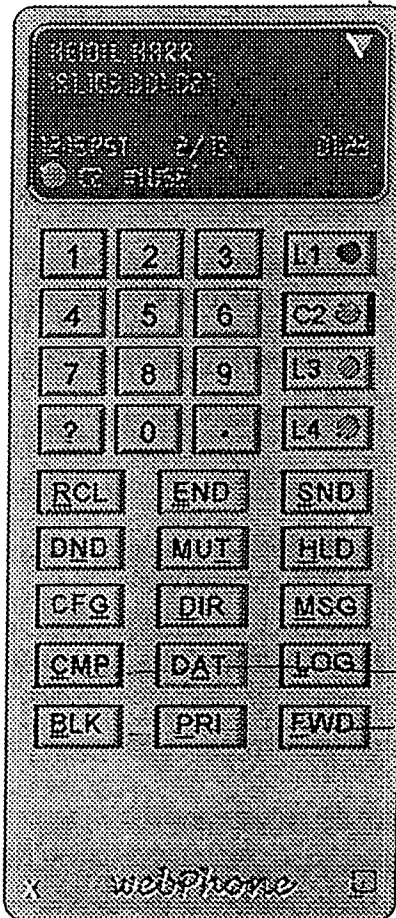
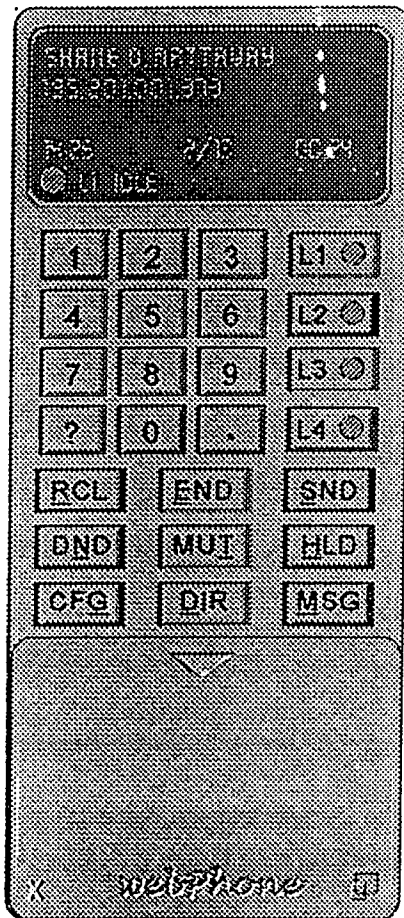
### Point to Point calling Mechanism

The diagram in figure 38 illustrates the mechanism by which the *webPhone* places calls and connects to other *webPhone* users who are connected to the internet via dialup SLIP/PPP lines via their 14.4/28.8 modems.

If the remote *webPhone* has a fixed IP address, the user transmits *<Call>* thereby bypassing the *ConnectRequest/ConnectOK* steps to establish a connection. *WebPhones* always maintain 1 open socket listening for a *Call*. Therefore, if all 4 lines are in use, the *webPhone* will send back a *<Busy>* to the caller.

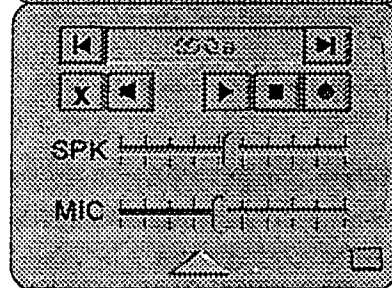
### Calling Scenarios

1. Recipient is offline  
initiator times out, kills socket, plays offline.wav  
initiator can e-mail {VMAIL}
2. Recipient has all 4 lines in use  
recipient sends back *Busy*, initiator plays busy.wav  
initiator can transmit *<Vmail>*
3. Recipient is on-line but does not answer  
initiator times out on *<ConnectOK>*, recipient's answering machine plays ogm.wav  
initiator can transmit *<Vmail>*
4. Recipient goes offline after transmitting *<ConnectOK>*  
initiator fails on transmitting *<Call>*, plays offline.wav  
initiator can e-mail {VMAIL}
5. Initiator goes offline after sending {CALL} and another *webPhone* gets the same IP address assigned and receives the *<ConnectOK>* from the recipient (extremely low probability of occurrence)  
only if the new initiator has an open socket listening for a *<ConnectOK>* from another party will he/she receive the *<ConnectOK>* from the wrong party, the initiator checks the session number in the *<ConnectOK>* and discovers the mismatch and disregards the transmission.  
in any event, the recipient will time out on *<Call>*
6. Recipient or initiator goes offline during the conversation  
failure on read/write to socket occurs both parties announce offline and can e-mail {VMAIL}.



**USR**

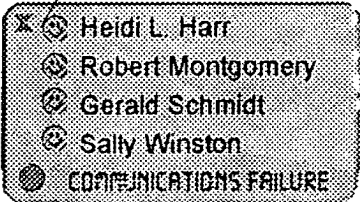
present on ITEL operator's  
webPhone to obtain a user's  
webphone.cfg file



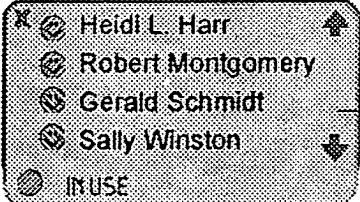


CNF list  
PRI list  
BLK list  
CMP list

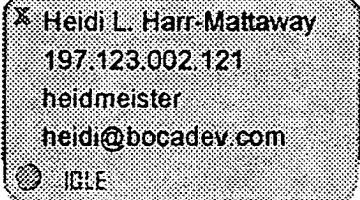
*different icon for remote hold*



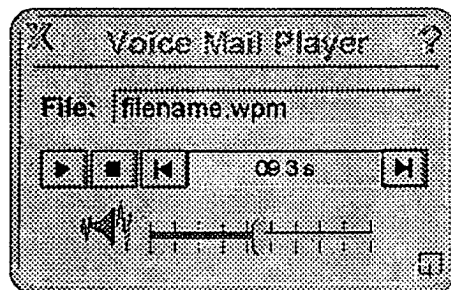
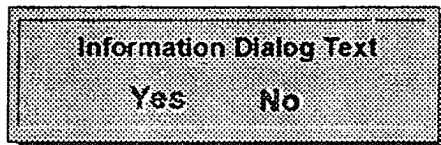
CNF list  
PRI list  
BLK list  
CMP list



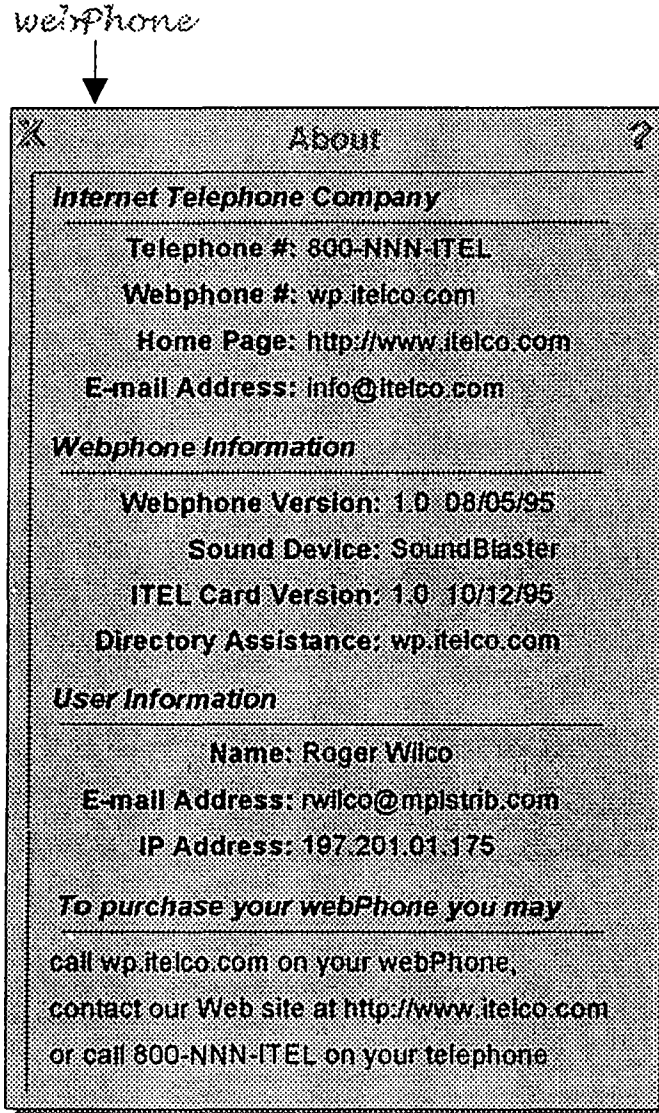
*more than 5 in list*

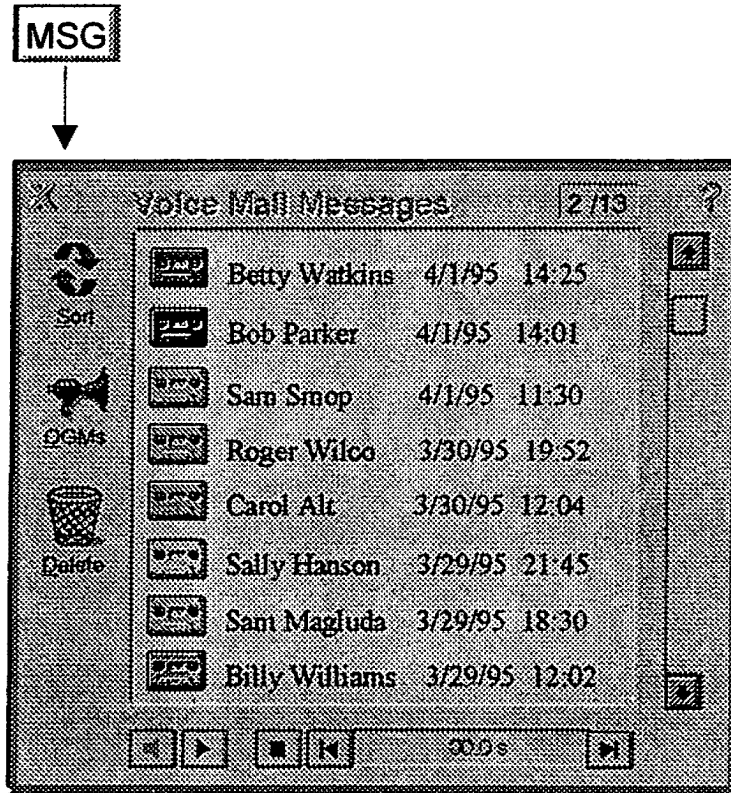


*speed dial party info  
Line party info  
FWD party info  
see party info*

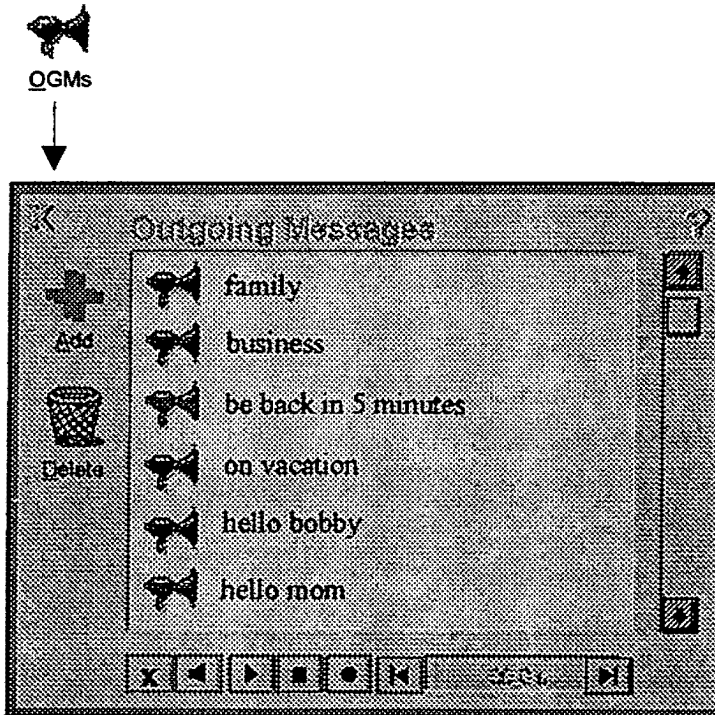



wpmplay.exe  
plays saved voice mail files  
located in the file system

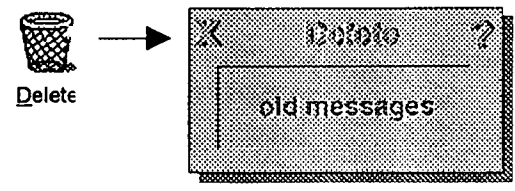
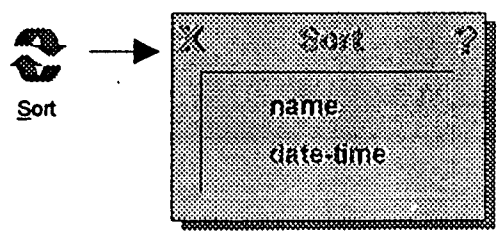
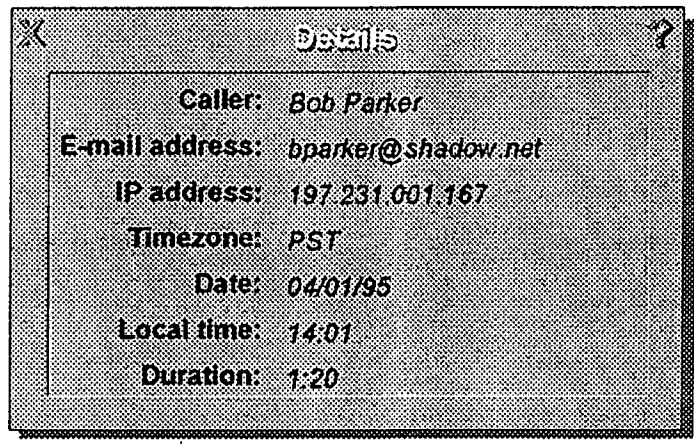
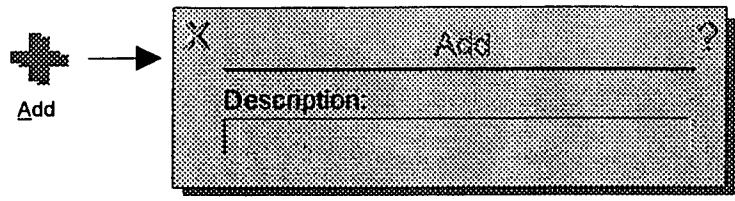


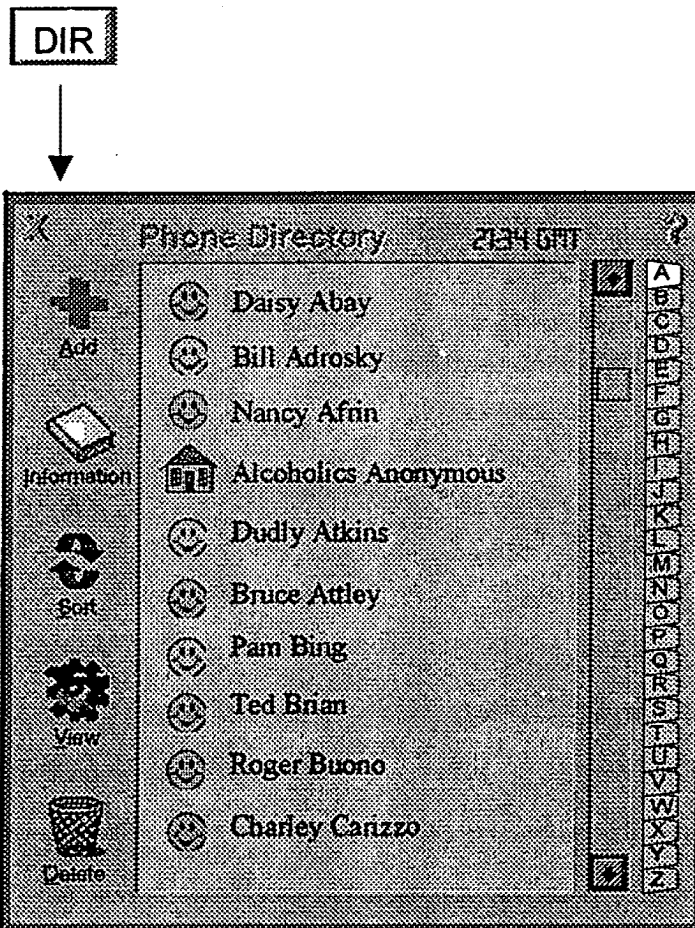


- dbl click - playback all selected*
- left click (ctrl left click) - select/deselect*
- Alt-left click - select/deselect All*
- right click - message details*
- drag to move to File Manager dir*  
*or append to another vmail msg*
- Ctrl-drag to copy to File Manager dir*



-  **dbl click** - playback all selected
- left click** - select/deselect
- Alt-left click** - select/deselect All
- right click** - OGM details
- drag to DIR entry** to assign OGM





- left click** - select/deselect entry
- Alt-click** - select/deselect All entries
- dbl click** - call entry
- right click** -update entry
- drag** to number pad position for speed dial  
or to [FWD] to assign to call forwarding  
or to idle [Ln] to call on that line

**Add**

Person Place

First Name:

Last Name:

Alias:

E-mail Address:

IP Address:

TimeZone:  ▼

enable call blocking

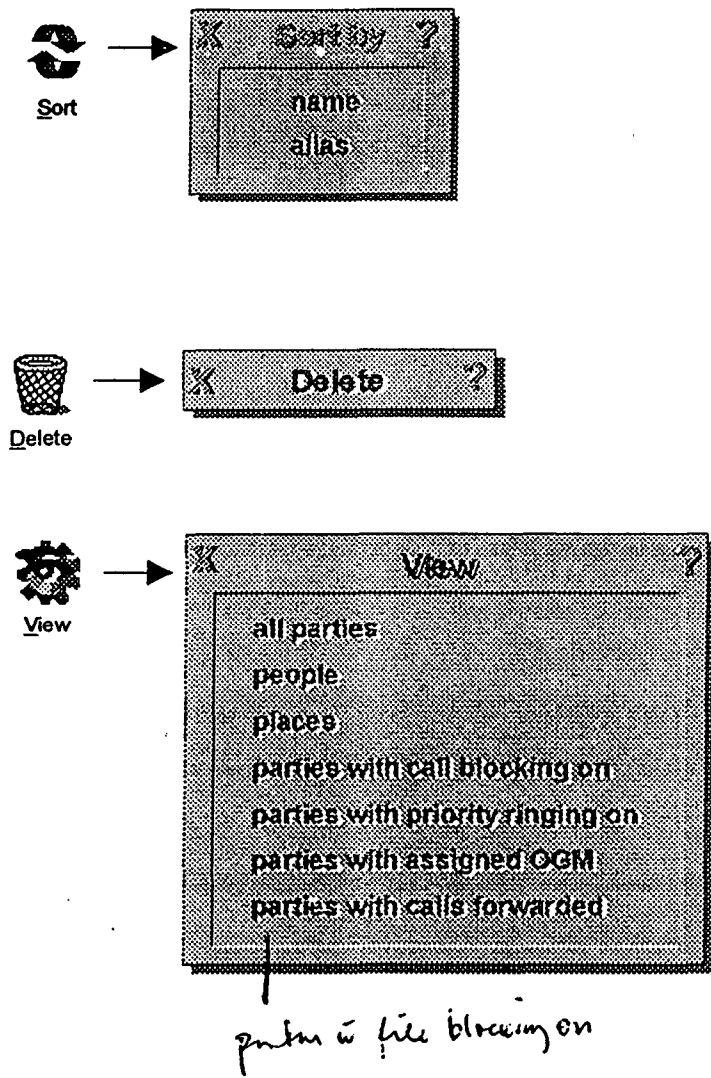
action:  reject call  allow voice mail

enable file receive blocking

enable priority ringing

use CGM:

forward calls to:








% Any numbers follow  
? Any single char



Information

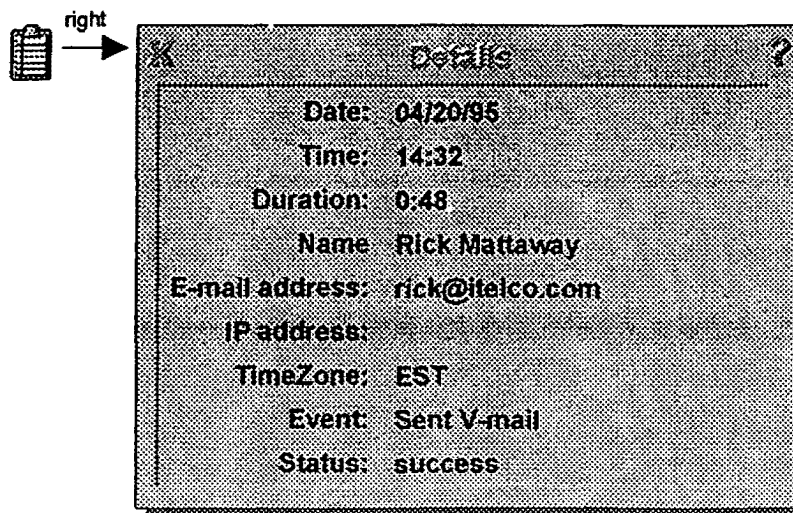
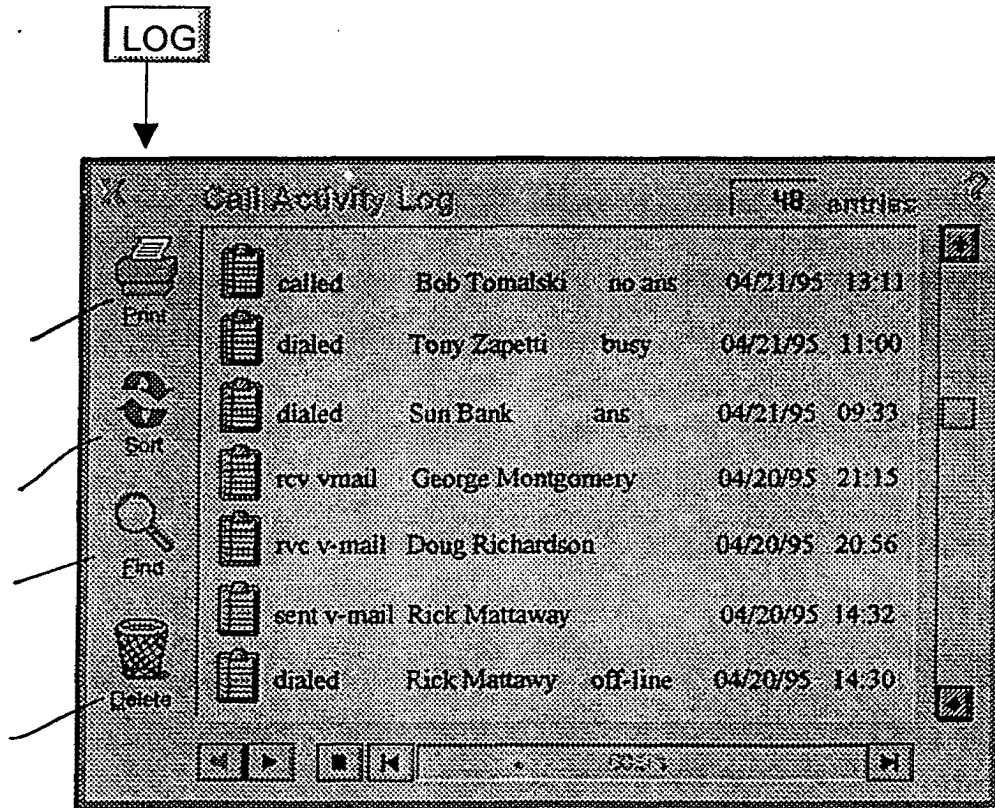
ITEL Directory	Local Directory
Person	Place
First Name: roger	
Last Name: wilco	
City: minneapolis	
State or Province: Mn	
Country: USA	
Postal Zipcode:	
Telephone #:	

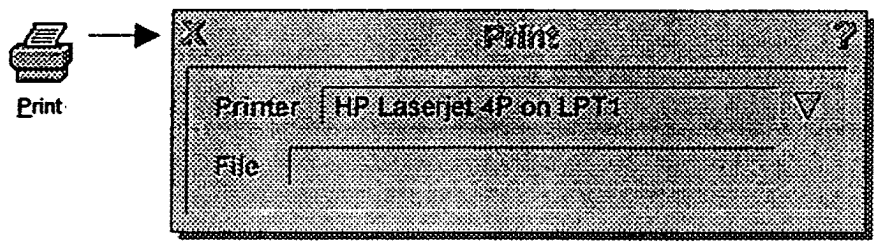
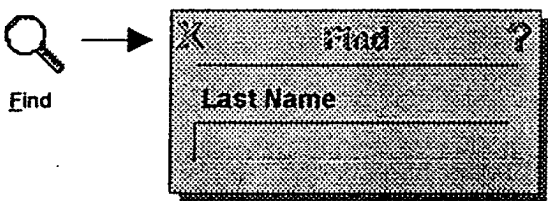
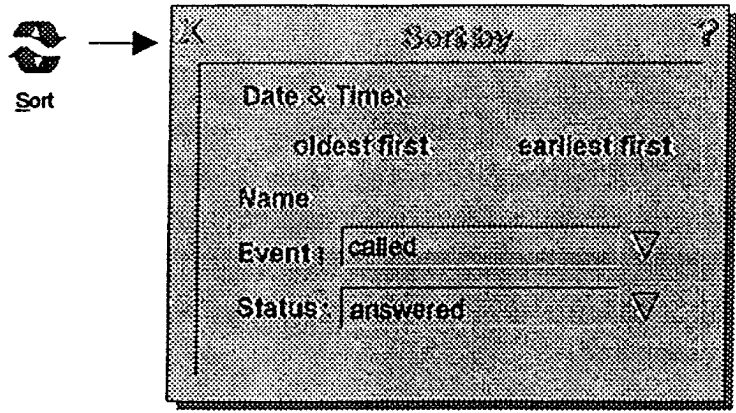
	Roger Wilco	rwilco@bio.unt.edu	<input checked="" type="checkbox"/>
	Roger Wilco	roger@biggy.com	<input type="checkbox"/>
	Roger Wilco	rdw@mpis.pol.gov	<input checked="" type="checkbox"/>

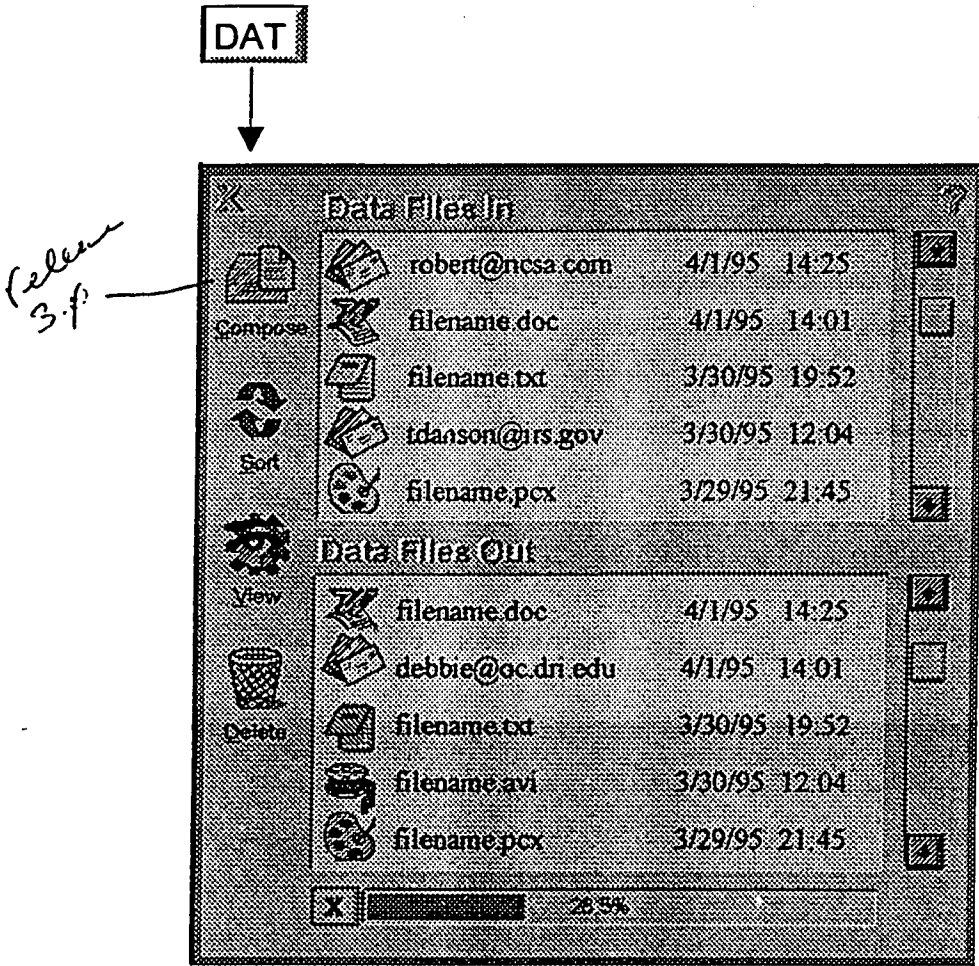
x 8 of 21 parties

Release  
3.8

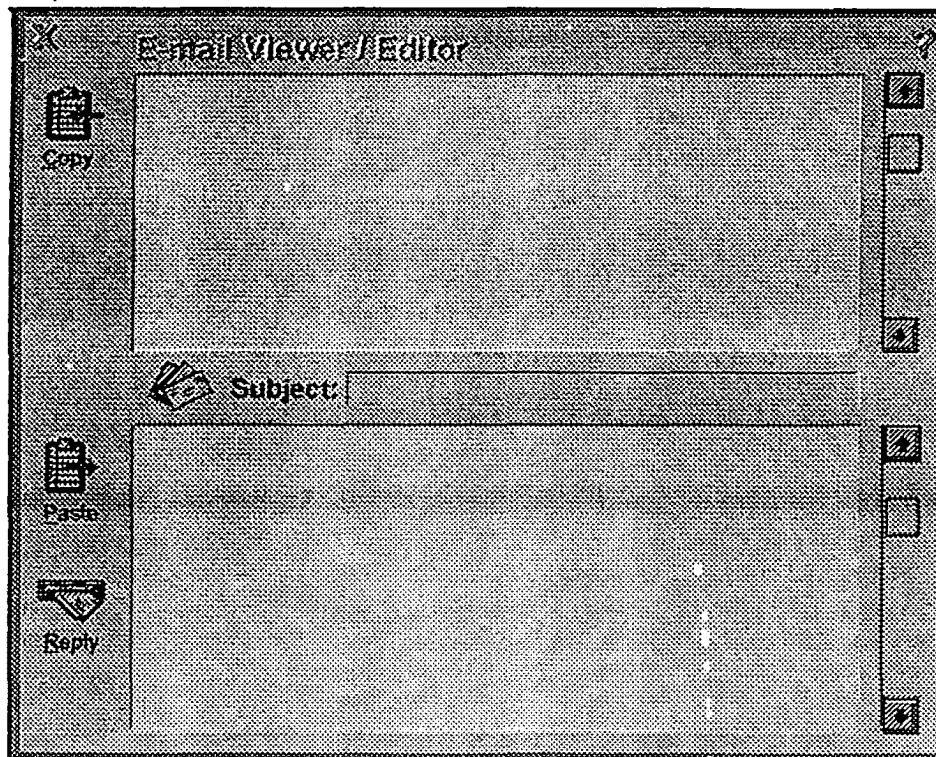
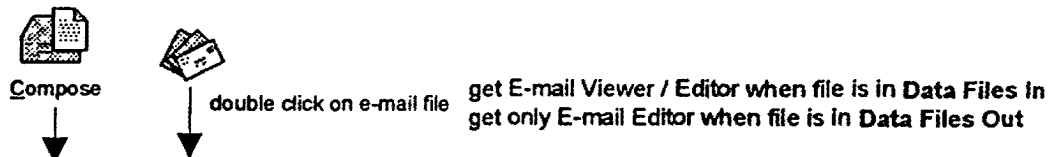
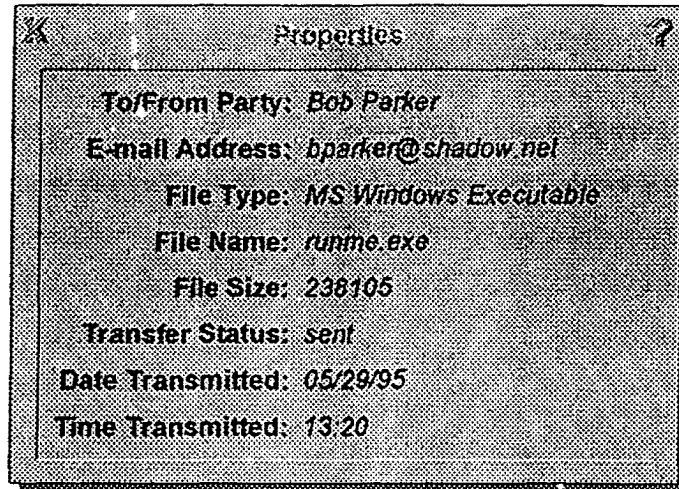
Dir add

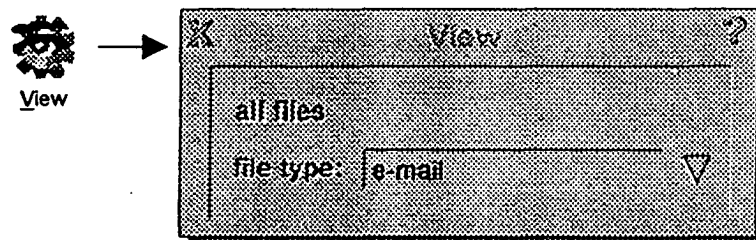
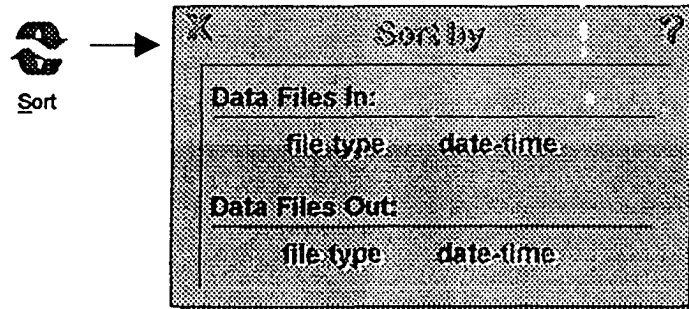






right click on file to obtain properties:





CFG

Configure

User Info Phone Ans Maching Phone Directory Sound Effects Audio Card Activity Log

First Name:

Last Name:

Alias:

E-mail Address:

IP Address:

TimeZone: GMT

Street Address:

Apt/Suite #:

City:

State/Province:

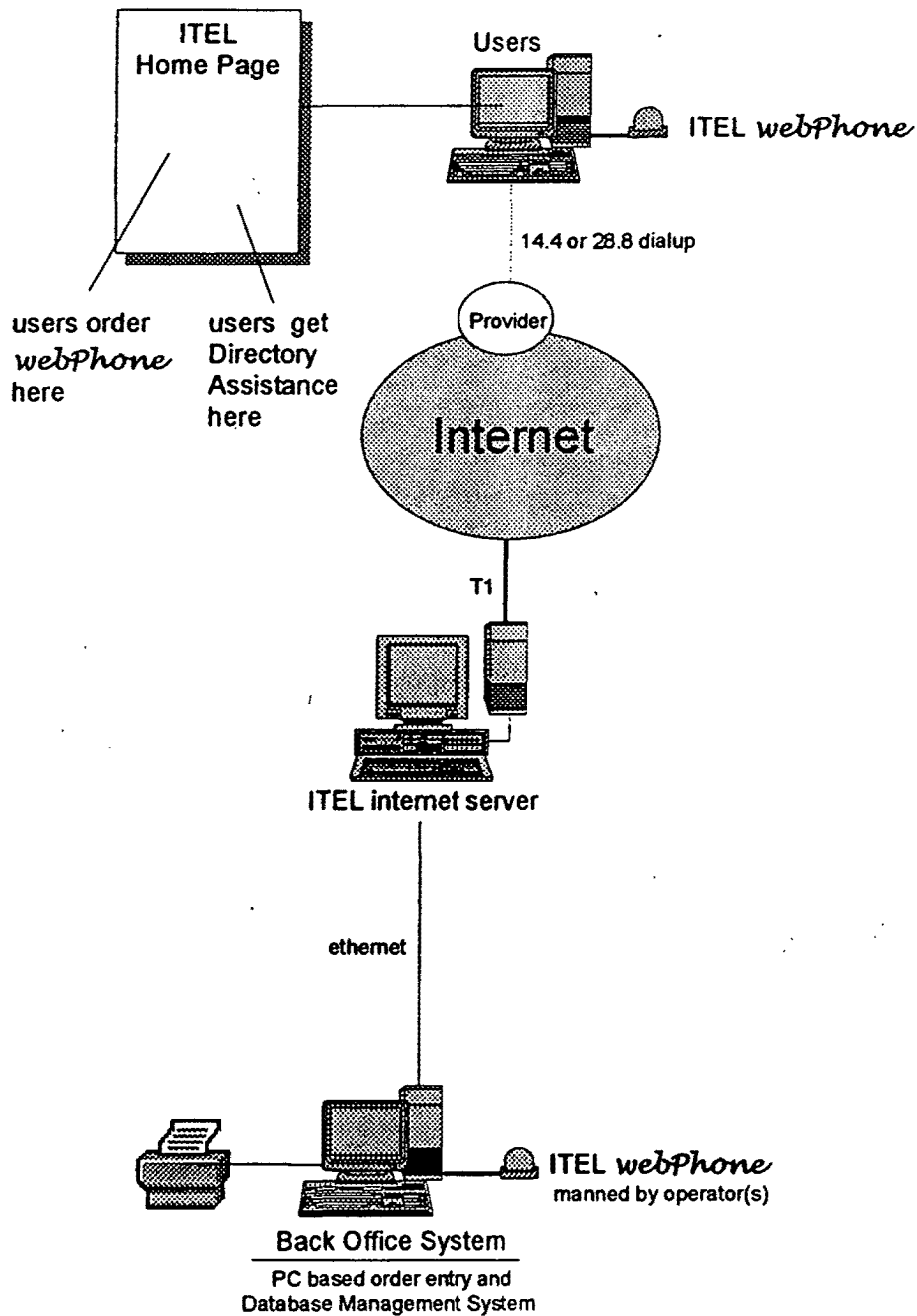
Zipcode:

Country:

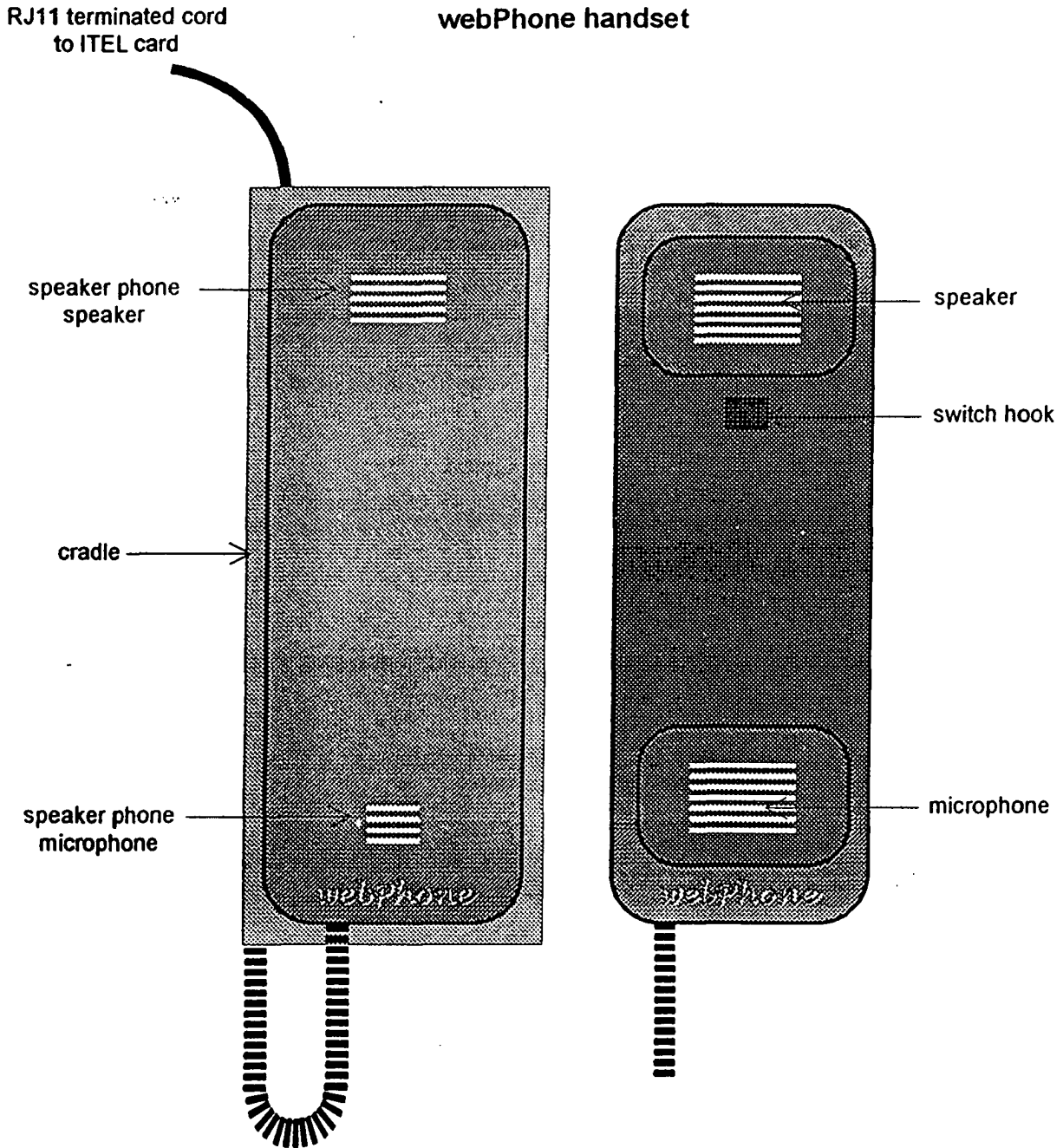
Telephone #:

Fax #:

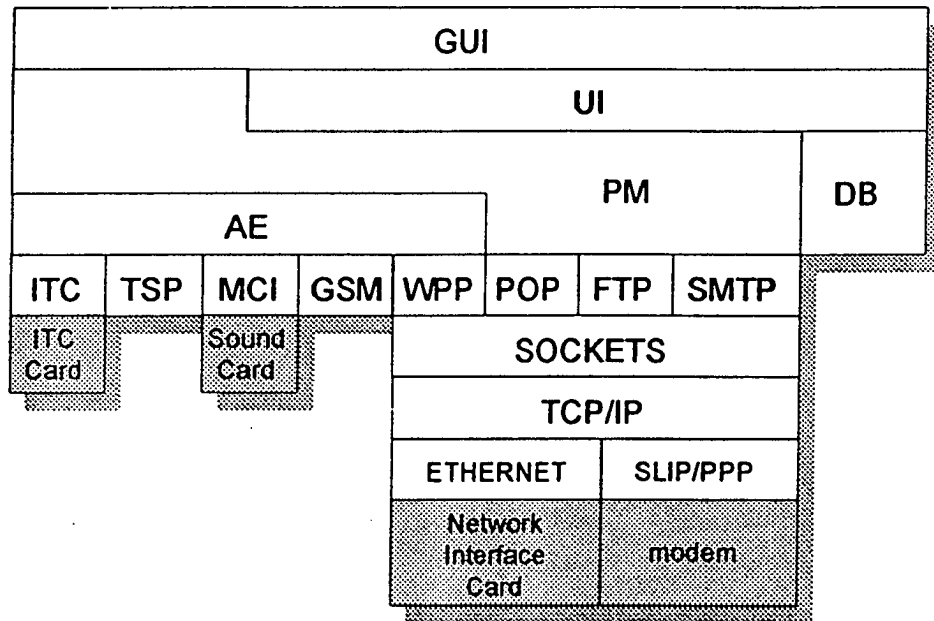
Company Name:



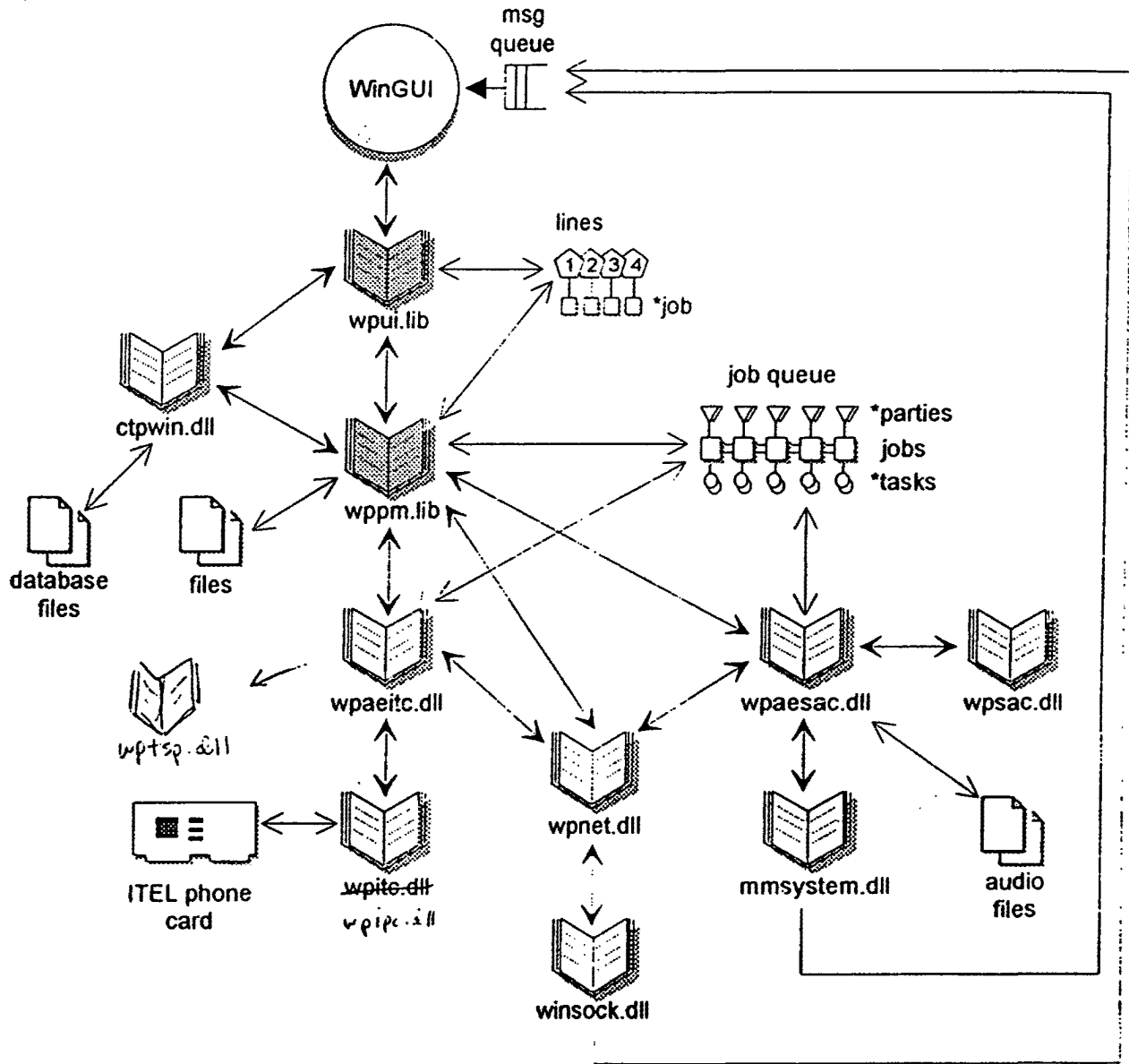




System Architecture



### Software Architecture



database	column name	type	index	comment
webphone.cfg				webphone\webphone.cfg, only 1 record
	state	uchar		0:crippled   1:registered
	version	char 4		webphone.exe version - n.nn, n=0-9
	dateTime	ulong		installation datetime in secs from 00:00 Jan 1, 1970 GMT
	sndDevice	char 25		name of sound card device driver, null if not found
	ipc	uchar		ITEL Phone Card (IPC) - 0:not found   1:found
	ipcVersion	char 4		n.nn, n=0-9
	ipcDateTime	ulong		secs from 00:00 Jan 1, 1970 GMT
	voxLevel	ulong		snd card mic voice activation level setting, units = ?
	firstName	char 10		user's first name
	lastName	char 25		user's last name
	alias	char 10		user's alias or call handle
	emailAddr	char 50		user's e-mail address
	IPAddr	ulong		user's current IP address (assigned if slip/ppp)
	streetAddr	char 50		
	apt	char 5		
	city	char 20		
	state	char 20		
	country	char 20		
	zipcode	char 10		
	phone	char 15		
	fax	char 15		
	company	char 25		
	timezone	uchar		index in TZ array
	infoIPAddr	ulong		IP addr of dir assistance server
	infoHostname	char 20		hostname of dir assistance server
	iconState	uchar		on top when -> 0:never   1:always   2:active
	popFrequency	uchar		seconds
	sndCardSpkr	uchar		use snd card as spkr phone -> 0:disabled   1:enabled
	callBlockAction	uchar		when call blocking enabled -> 0:reject   1:ansMachine
	fileTransfer	uchar		0:disabled   1:enabled
	encrypt	uchar		0:disabled   1:enabled
	ansMachine	uchar		0:disabled   1:enabled
	timeToAns	uchar		seconds until ans machine picks up
	sndCardVmail	uchar		play vmail on snd card spkr -> 0:disabled   1:enabled

ITP  
 a char  
~~25~~  
 50

Spk  
 mic  
 value  
 web 0,1,2,9

database	column_name	type	index	comment
	ogmNoVmail	uchar		play ogm do not accept vmail -> 0:disabled   1:enabled
	hearOgm	uchar		hear ogm when played -> 0:disabled   1:enabled
	noansWav	char 8		filename of wave file to play when no ans
	noansRepeat	uchar		seconds to pause between plays -> 0:no repeat   >0 pause secs
	offlineWav	char 8		filename of wave file to play when offline
	offlineRepeat	uchar		seconds to pause between plays -> 0:no repeat   >0 pause secs
	busyWav	char 8		filename of wave file to play when busy
	busyRepeat	uchar		seconds to pause between plays -> 0:no repeat   >0 pause secs
	dialingWav	char 8		filename of wave file to play when dialing
	dialingRepeat	uchar		seconds to pause between plays -> 0:no repeat   >0 pause secs
	callWav	char 8		filename of wave file to play when call arrives
	callRepeat	uchar		seconds to pause between plays -> 0:no repeat   >0 pause secs
	badAddrWav	char 8		filename of wave file to play when bad email or IP address given
	badAddrRepeat	uchar		seconds to pause between plays -> 0:no repeat   >0 pause secs
	errorWav	char 8		filename of wave file to play when error occurs
	errorRepeat	uchar		seconds to pause between plays -> 0:no repeat   >0 pause secs
	holdWav	char 8		filename of wave file to play when placed on hold
	holdRepeat	uchar		seconds to pause between plays -> 0:no repeat   >0 pause secs
	vmailWav	char 8		filename of wave file to play when vmail arrives
	vmailRepeat	uchar		seconds to pause between plays -> 0:no repeat   >0 pause secs
	priorityWav	char 8		filename of wave file to play when priority ring enabled party calls
	priorityRepeat	uchar		seconds to pause between plays -> 0:no repeat   >0 pause secs
	callackWav	char 8		filename of wave file to play when call acknowledge arrives
	callackRepeat	uchar		seconds to pause between plays -> 0:no repeat   >0 pause secs
	log	uchar		activity log -> 0:disable   1:enable
	logEvents	uchar		bitmap of events to log -> high nibble = type, low nibble = status
	wpHPos	ulong		saved screen coord for webphone upper left horz pos in pixels
	wpVPos	ulong		saved screen coord for webphone upper left vert pos in pixels
	dirHPos	ulong		saved screen coord for phone dir upper left horz pos in pixels
	dirVPos	ulong		saved screen coord for phone dir upper left vert pos in pixels
	msgHPos	ulong		saved screen coord for vmail msgs upper left horz pos in pixels
	msgVPos	ulong		saved screen coord for vmail msgs upper left vert pos in pixels
	logHPos	ulong		saved screen coord for activity log upper left horz pos in pixels
	logVPos	ulong		saved screen coord for activity log upper left vert pos in pixels
	cfgHPos	ulong		saved screen coord for config upper left horz pos in pixels
	cfgVPos	ulong		saved screen coord for config files upper left vert pos in pixels

database	column name	type	index	comment
	datHPos	ulong		saved screen coord for data files upper left horz pos in pixels
	datVPos	ulong		saved screen coord for data files upper left vert pos in pixels
	iconHPos	ulong		saved screen coord for icon upper left horz pos in pixels
	iconVPos	ulong		saved screen coord for icon upper left vert pos in pixels
	session	ulong		next available session number in sequence
	vmailName	ulong		next available vmail name in sequence -> xxxxxxxx, x=0-9
	ogmName	ulong		next available ogm name in sequence -> xxxxxxxx, x=0-9

*positions of all dialogs*

*phonedir.db*

column name	type	index	comment
number	ulong	key	unique identifier, assigned sequentially
firstName	char 10		
lastName	char 25	index	place name if place
alias	char 10	index	
emailAddr	char 50		
IPAddr	ulong	index	
timezone	uchar		index into TZ array
type	uchar	index	0:person   1:place
priority	uchar	index	0:disable   1:enable
blocked	uchar	index	0:disable   1:enable
blockAction	uchar		0:REJECT   1:ACCEPTVMAIL
ogmNumber	ulong	index	link to ogm in ogm.dir
speedDial	uchar	index	position: 1 - 10, 0:unassigned
callFoward	uchar	index	0:disable   1:enable
forwardParty	ulong		link to party in phonedir.db
fileBlock	uchar	index	0:disable   1:enable

*ogm*  
*uchar*  
*index*

*messages.dir*

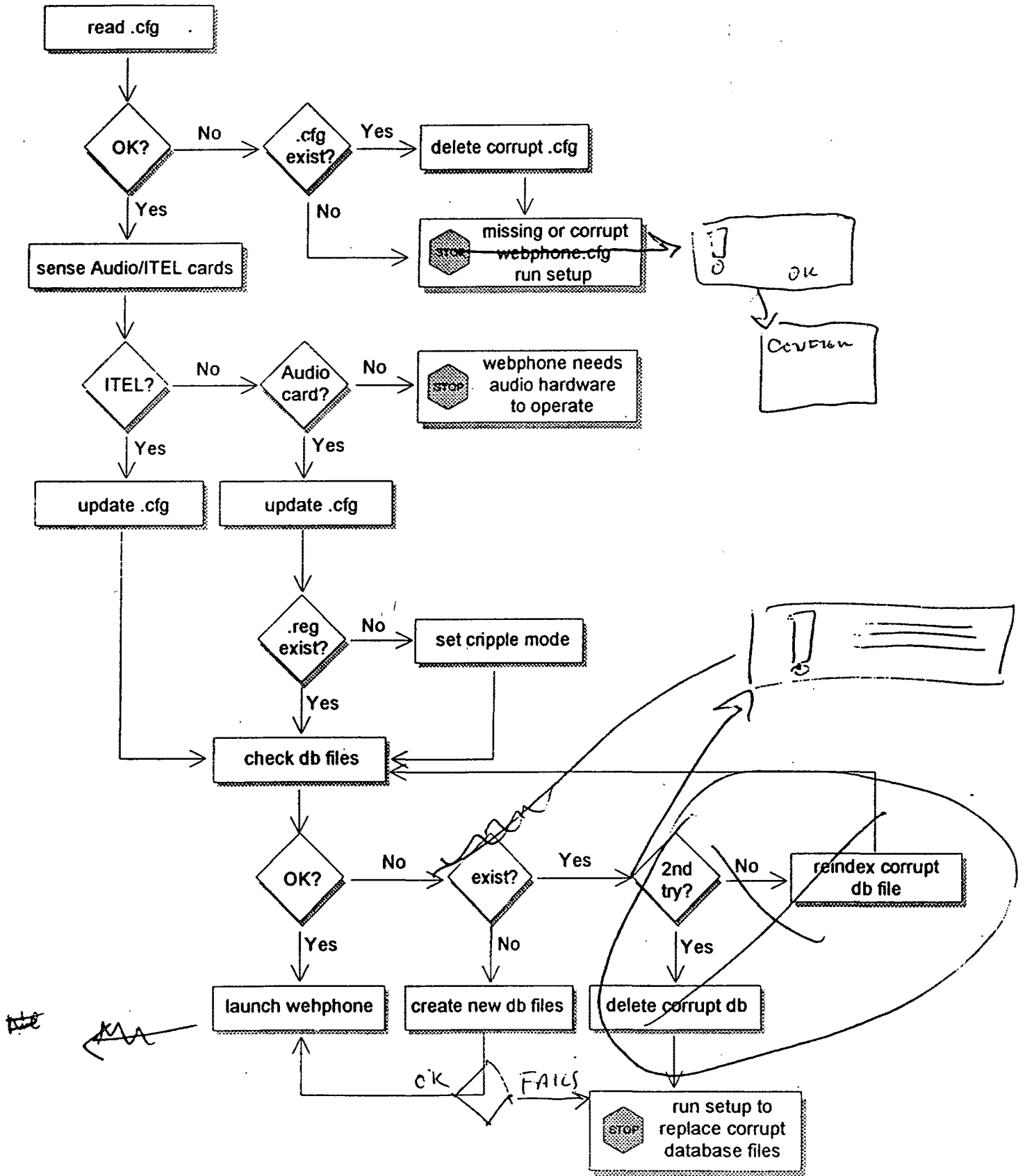
column name	type	index	comment
number	ulong	key	unique identifier, assigned sequentially
direction	uchar	index	0:in   1:out
state	uchar	index	0:old   1:new
type	uchar		0:gsm   1:tsp   2:cripple (play cvmlmsg.wav)

database	column name	type	Index	comment
	filename	char 8		xxxxxxxx.wpm, x=0-9, assigned sequentially
	firstName	char 10		null if place
	lastName	char 25	index	place name if place
	emailAddr	char 50		
	IPaddr	ulong		
	dateTime	ulong	index	secs from 00:00 Jan 1, 1970 GMT
	duration	ulong		secs
<i>files.dir</i>				webphone\files\files.dir
	number	ulong	key	unique identifier, assigned sequentially
	direction	uchar	index	0:in   1:out
	type	uchar	index	0:executable   1:email   2:text   3:winapp
	filename	char 13		*.ext, ext=exe,bat,sys,txt,doc,wri,xls,pm5,...
	firstName	char 10		null if place
	lastName	char 25	index	place name if place
	emailAddr	char 50		
	IPaddr	ulong		
	dateTime	ulong	index	in or out datetime in secs from 00:00 Jan 1, 1970 GMT
	fileDate	char 8		mm-dd-yy
	fileTime	char 6		hh:mmq, q=a   p
	fileSize	ulong		in bytes
<i>activity.log</i>				webphone\activity.log
	number	ulong	key	unique identifier, assigned sequentially
	firstName	char 10		null if a place
	lastName	char 25	index	
	dateTime	ulong	index	secs from 00:00 Jan 1, 1970 GMT
	emailAddr	char 50		
	IPaddr	ulong		
	type	uchar	index	0:called 1:dialed 2:camped 3:rcv vmail 4:snt vmail 5:rcv file 6:snt file
	status	uchar	index	0:ans 1:noans 2:busy 3:offline 4:success 5:failure 6:disconnect

database	column name	type	Index	comment
	vmail	ulong		link to vmail msg in messages.dir
<i>ogm.dir</i>	number	ulong	key	webphone\ogm\ogm.dir unique identifier, assigned sequentially
	filename	char 8		xxxxxxx.wpm, x=0-9, assigned sequentially
	dateTime	ulong		secs from 00:00 Jan 1, 1970 GMT
	description	char 25		
<i>camp.lst</i>	number	ulong	key	webphone\camp.lst unique identifier, assigned sequentially
	session	ulong	index	
	direction	uchar	index	0:campee   1:camper
	dateTime	ulong		
	firstName	char 10		null if a place
	lastName	char 25		
	emailAddr	char 50		
	IPAddr	ulong		

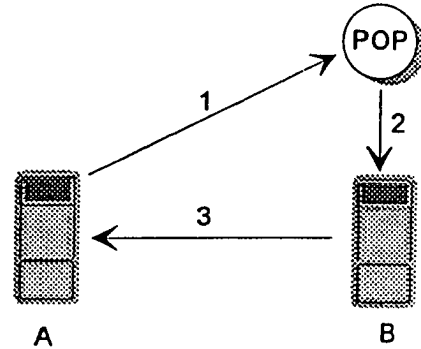


Startup



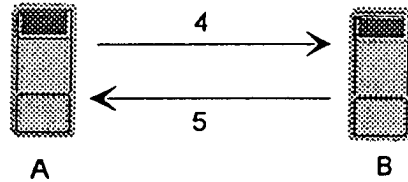
Point to Point Calling Scenario

1. A initiates call to B by sending {CALL}, A says CONNECTING
2. B polls POP and receives {CALL}
3. B xmts <ConnectOK> with B's IP address to A

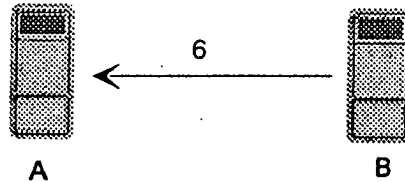


Note: If B's IP address was already known to A then the calling scenario would begin here at step 4:

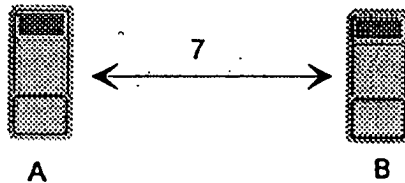
4. A xmts <Call> to B with A's user info
5. B xmts <CallAck> to A with B's user info, A says RINGING, A plays "ringout.wav", B says CALL



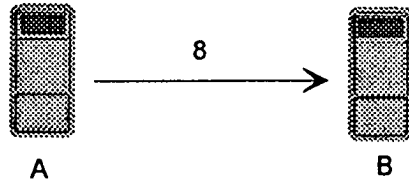
6. when B answers, B xmts <Answer> to A. A stops "ringout.wav" and B stops ringin.wav



7. A and B converse

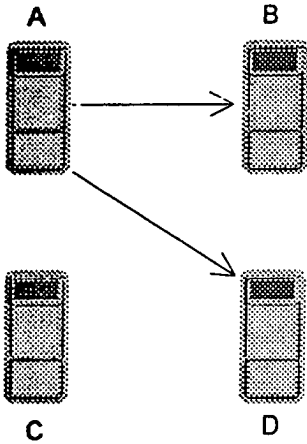


8. A or B presses [END] and xmts <End> to B or A.

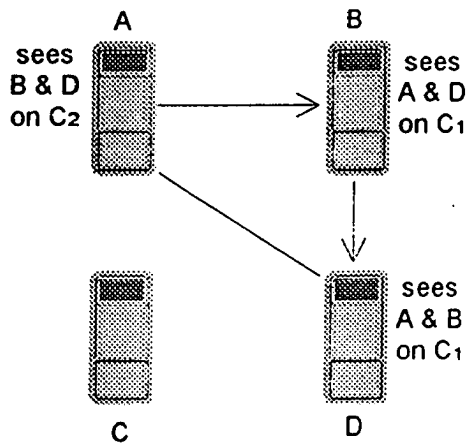


{ } is an e-mail message  
< > is a socket message

Conference Calling

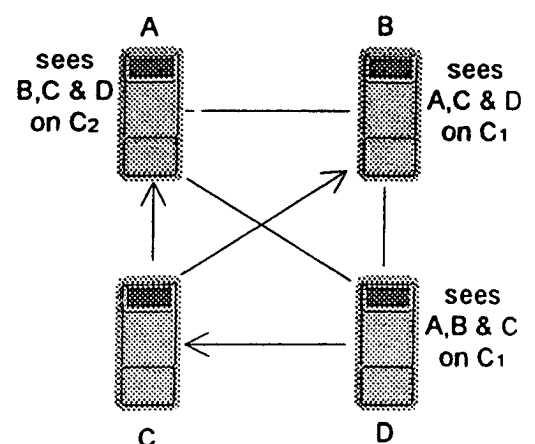


A calls B on L1 then calls D on L2



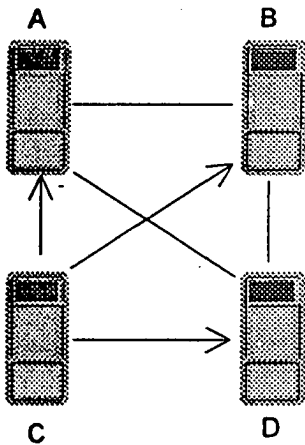
A places B onto L2 thereby conferencing with B & D. L2 then becomes C2. A instructs B to call D with <cnfadd>. B calls D with <cnfcall>.

A xmts to B & D  
B xmts to A & D  
D xmts to A & B

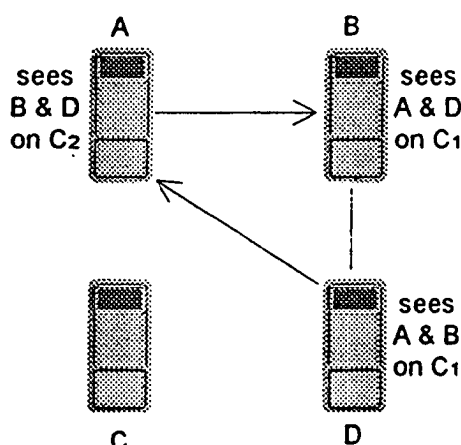


D now calls C and places C on conference. D instructs C to call A & B with <cnfadd>. C call A & B with <cnfcall>.

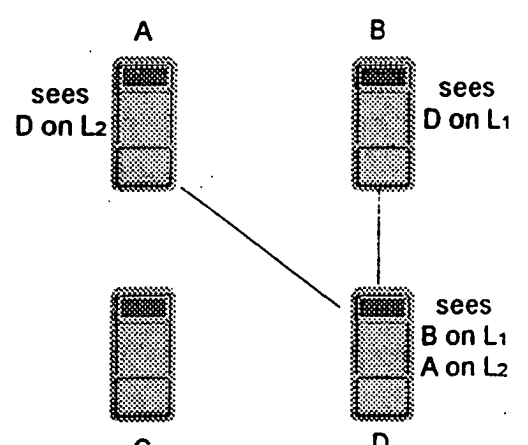
A xmts to B, C & D  
B xmts to A, C & D  
D xmts to A, B & C



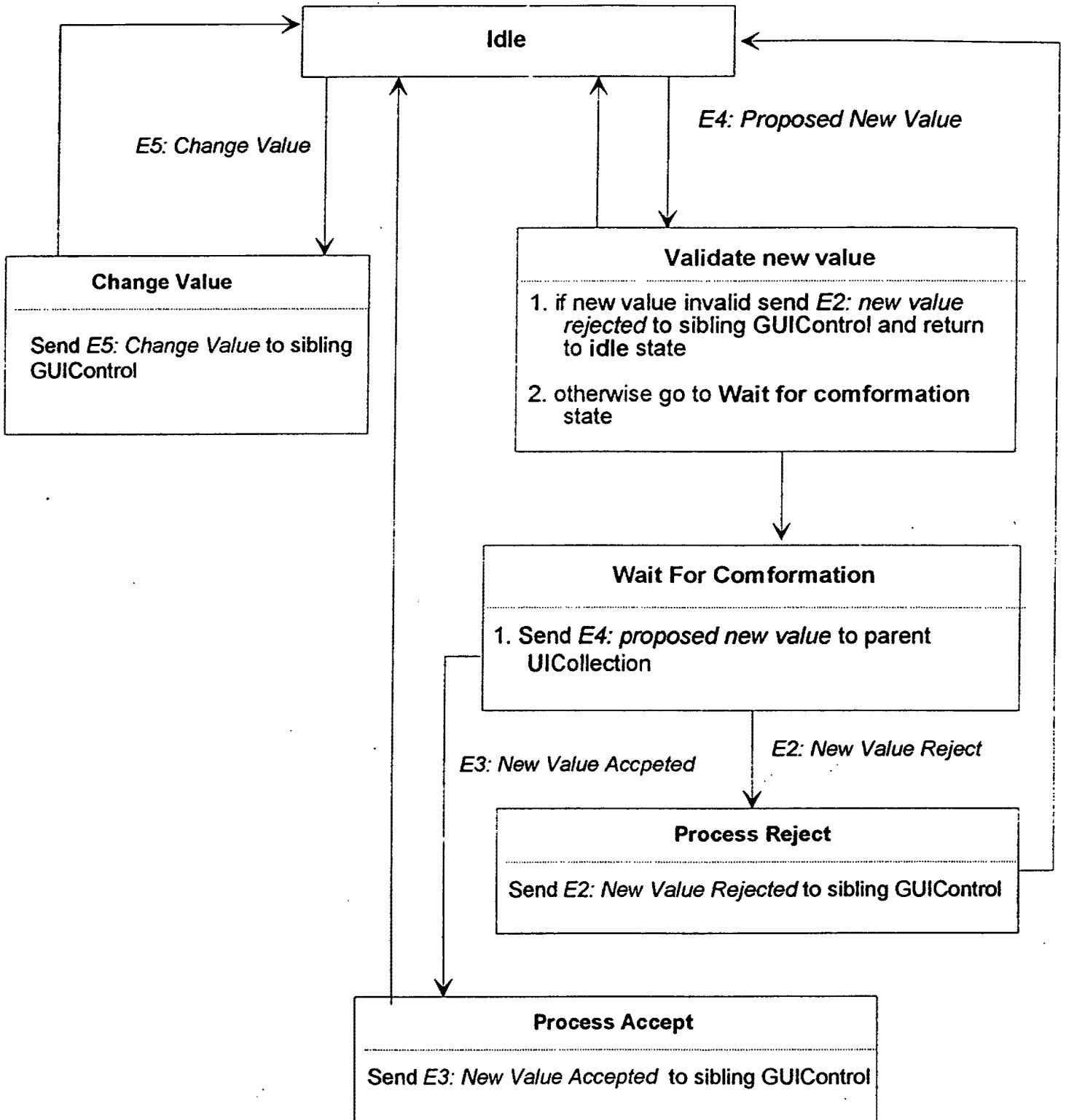
C ends call and sends <end> to A, B & D.



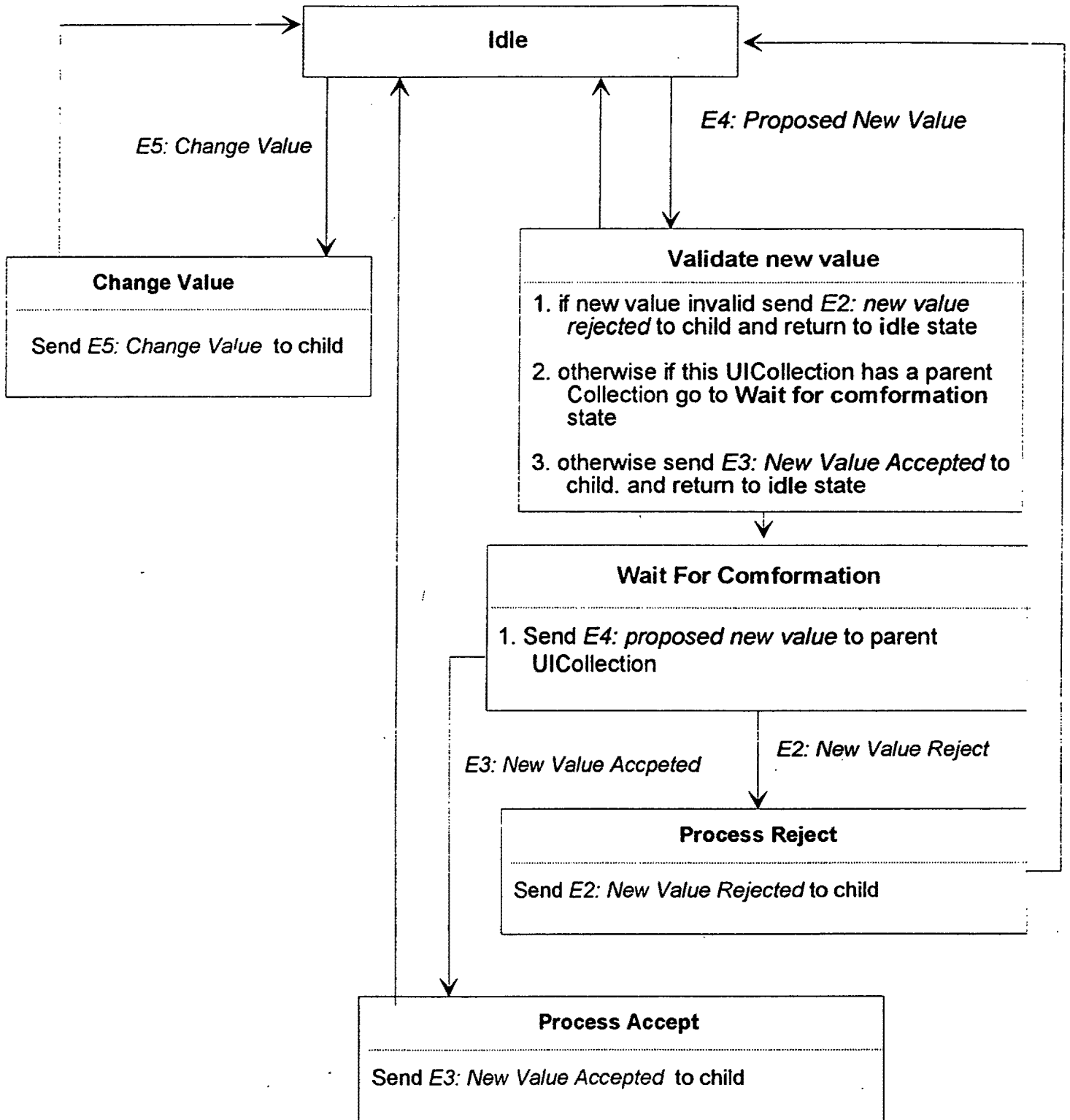
D transfers A onto L2 thereby dropping A from the conference on C1. C1 then becomes L1. D sends <cnfdrop> to A. A then sends <end> to B.

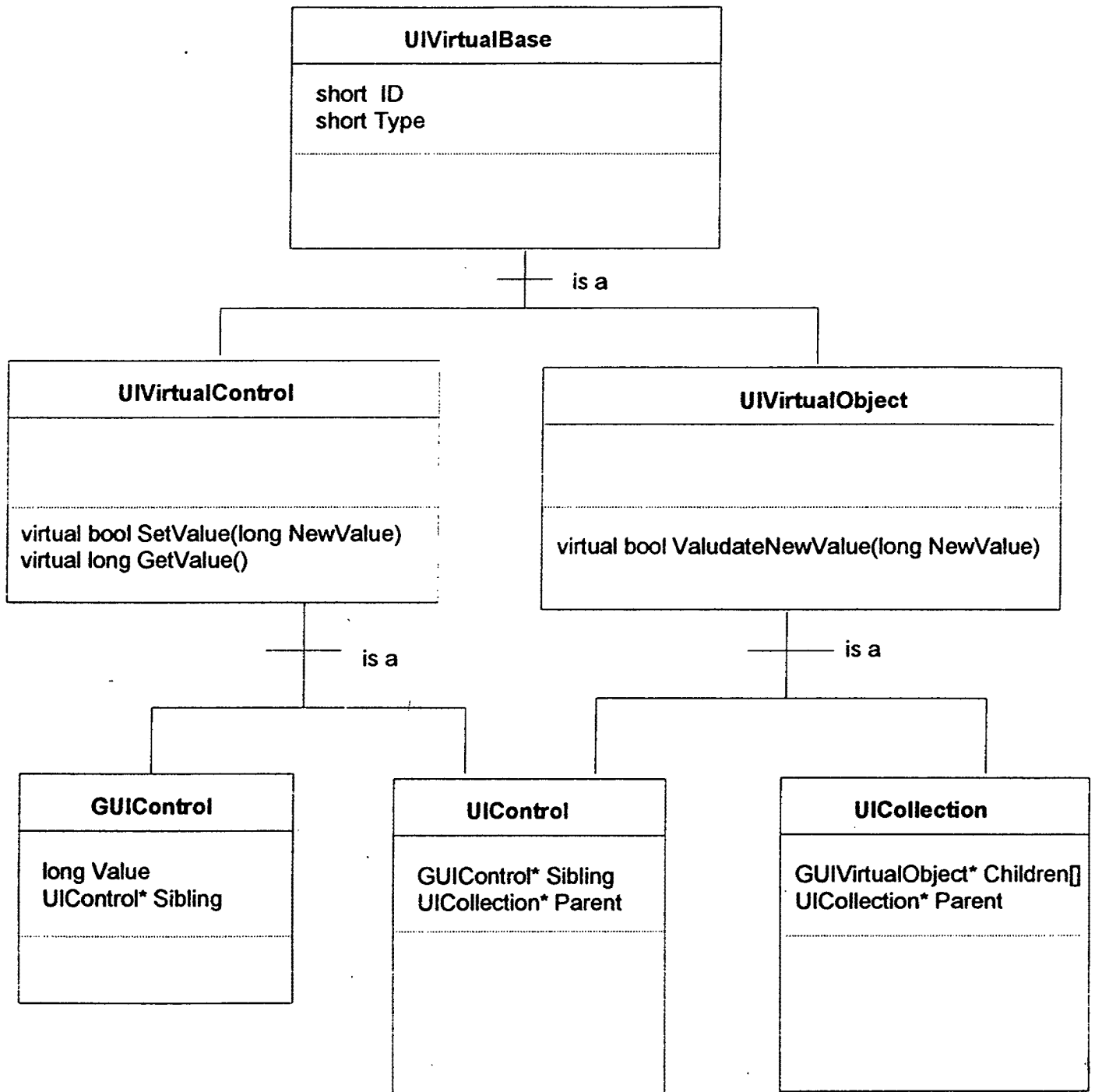


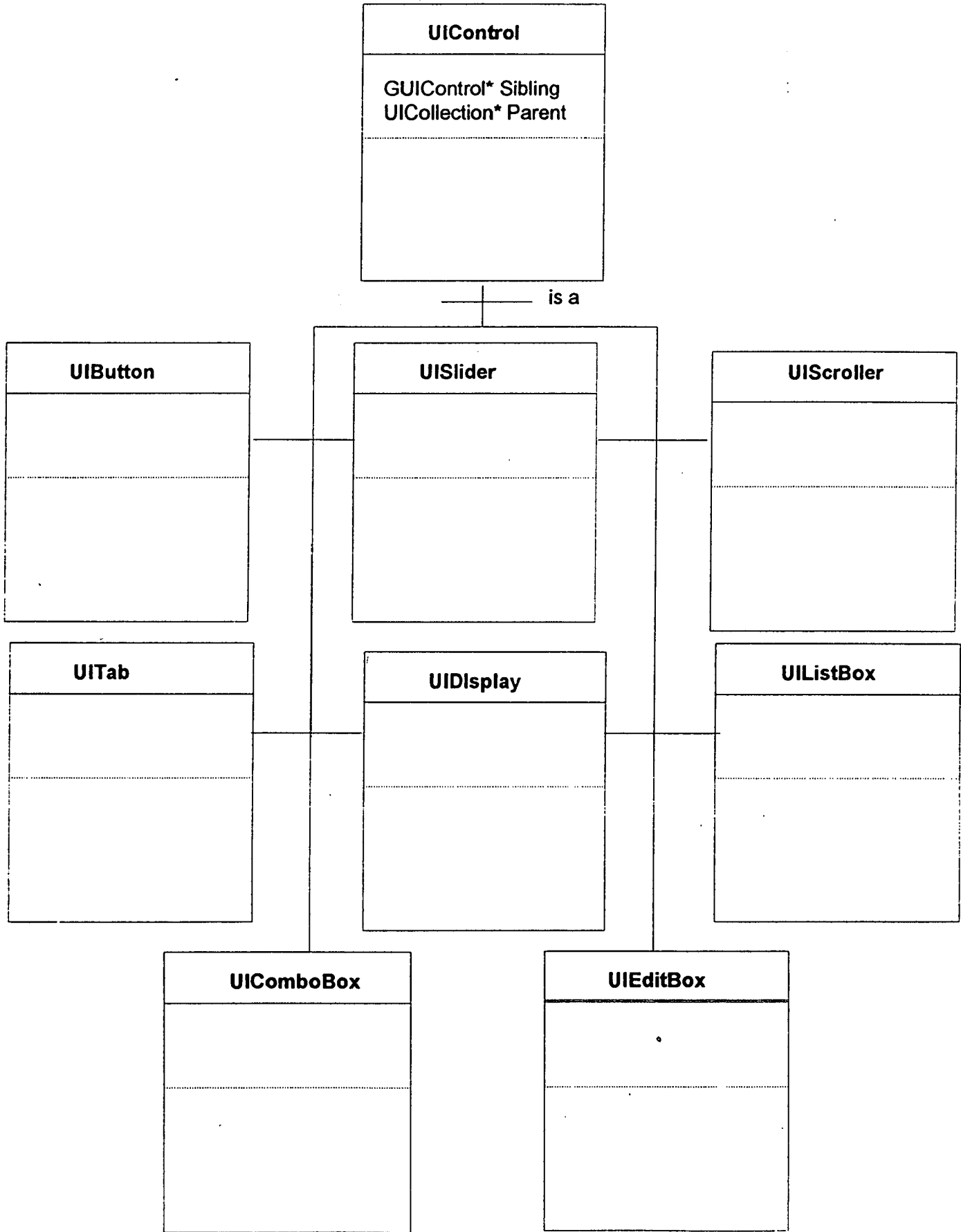
### UIControl STD

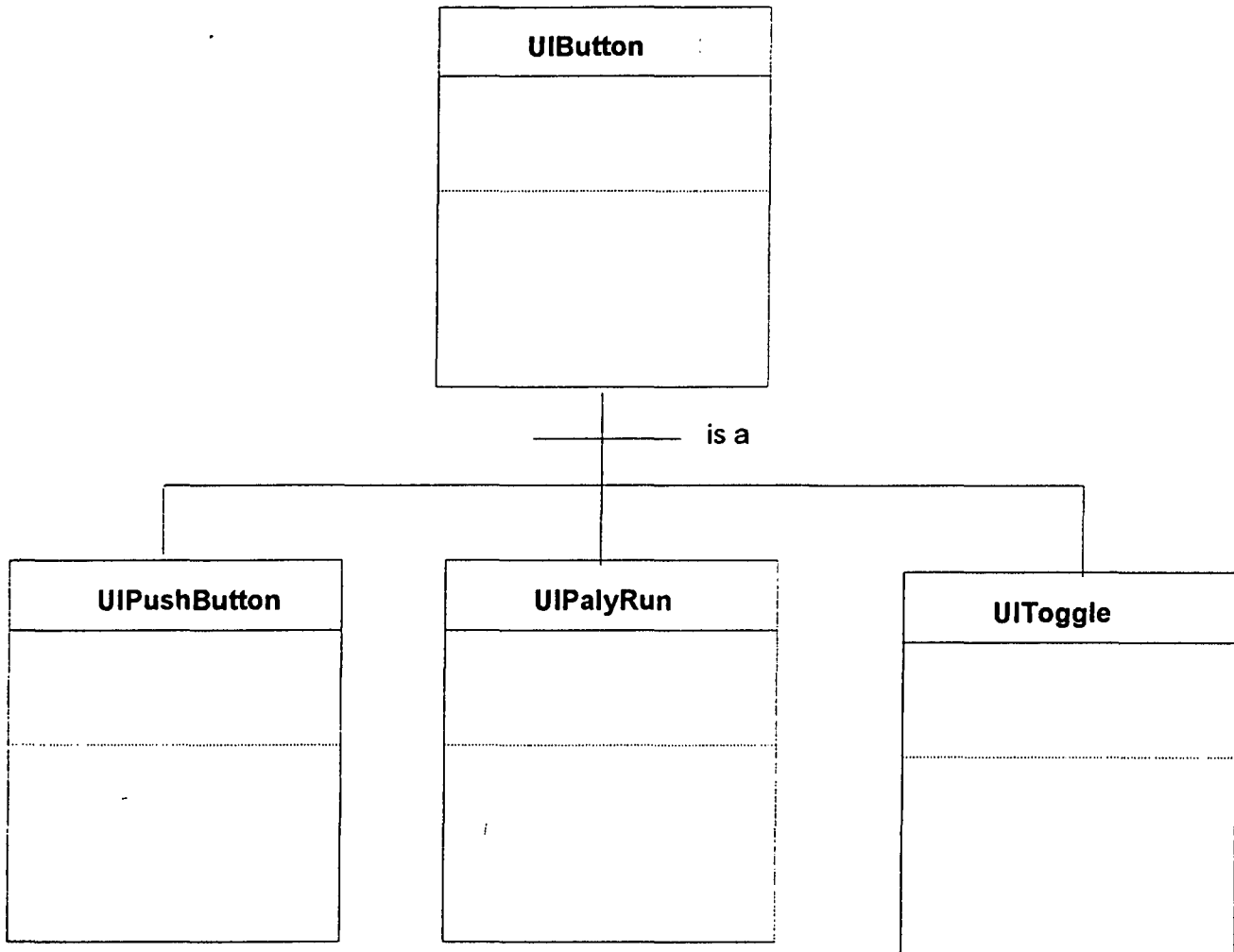


### UICollection STD

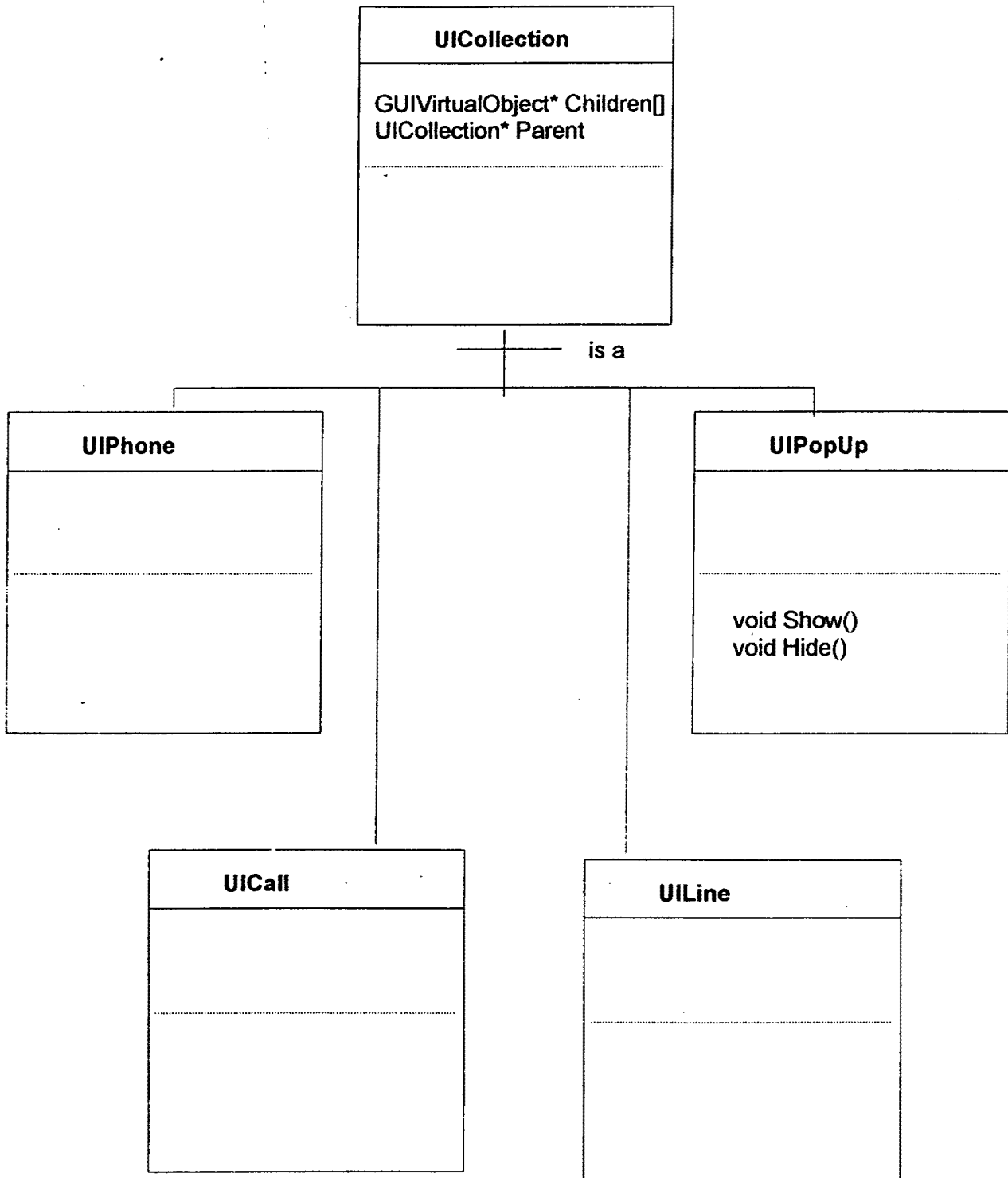




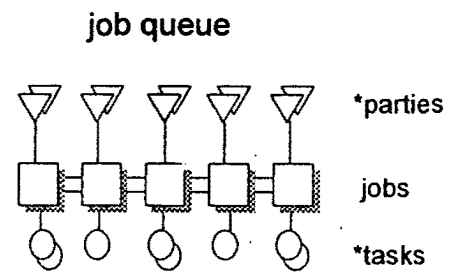
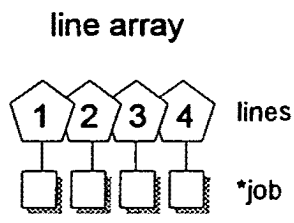
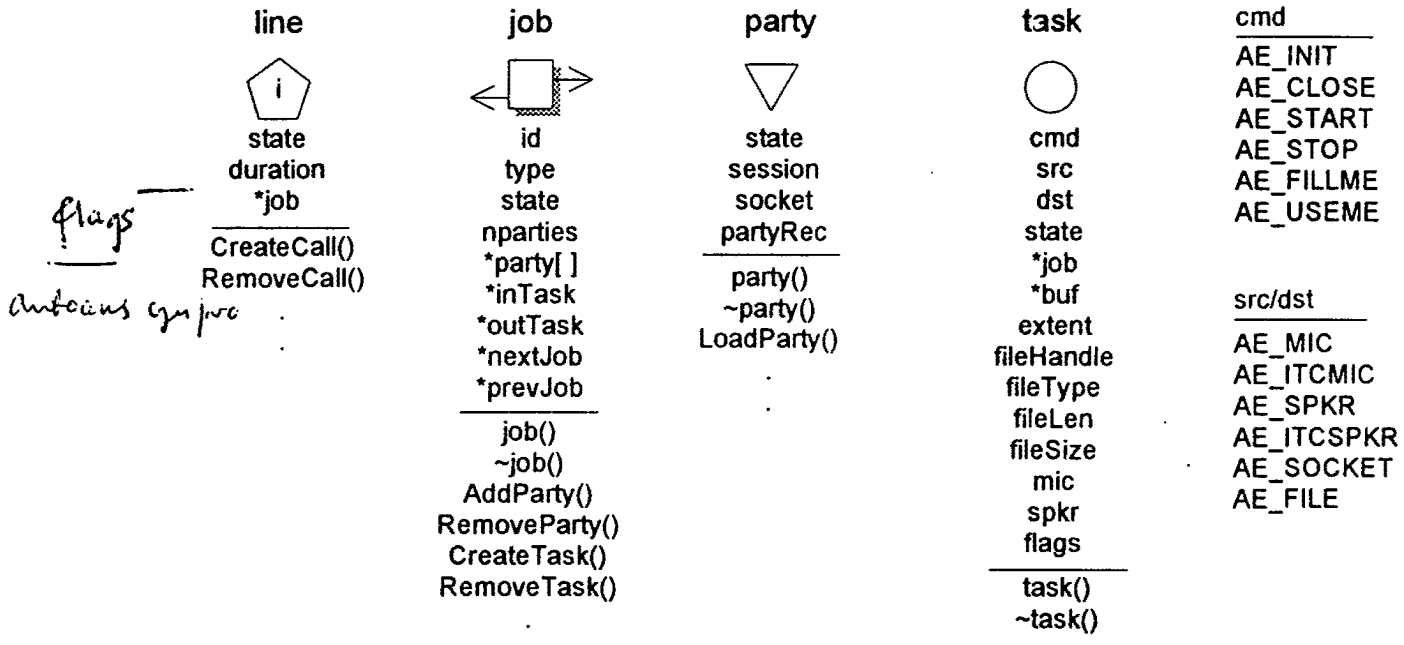






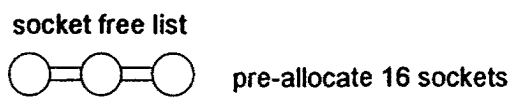


PhoneManager & AudioEngine Objects



Job \*timers [ WP\_MAXTIMERS ]  
index into timer array is TM\_?

TM\_?  
TM\_POLL  
TM\_OHELLO  
TM\_IHELLO  
TM\_CALLACK



Line States

state	value	led color	annunciate
LS_IDLE	0x00000000	gray	IDLE
LS_INUSE	0x00000001	green	INUSE
LS_OFFLINE	0x00000002	blue	OFFLINE
LS_CONNECTING	0x00000004	blue-green	CONNECTING
LS_CALL	0x00000008	blink green	CALL
LS_RINGOUT	0x00000010	blue-green	RINGING
LS_HOLD	0x00000020	blink red	HOLDING
LS_BUSY	0x00000040	blink blue	BUSY
LS_ANSMACHINE	0x00000080	green	ANSERING MACHINE
LS_REJECTED	0x00000100	blue	REJECTED
LS_DISCONNECTED	0x00000200	black	DISCONNECTED
LS_NETFAILURE	0x00000400	black	NETWORK FAILURE
LS_COMMFAILURE	0x00000800	black	COMMUNICATIONS FAILURE
LS_CAMPACK	0x00001000	blink blue-green	PARTY AVAILABLE
LS_OGMPLAY	0x00002000	blink green	PLAYING MESSAGE
LS_VMAILRCV	0x00004000	blink green	RECEIVING VOICE MAIL
LS_RECORD	0x00008000	red	RECORDING
LS_PLAY	0x00010000	orange-yellow	PLAYING
LS_SELECT	0x01000000	gray	IDLE
LS_MUTE	0x02000000	yellow	MUTE
LS_ONHOLD	0x04000000	red	ONHOLD

*LS\_TALK*      *0x09000000*      *green*      *TALK*  
*LS\_LISTEN*      *0x10000000*      *green*      *LISTEN*

**Job States**

state  
JS\_IDLE  
JS\_DONE  
JS\_SELECT  
JS\_OCALL  
JS\_ORING  
JS\_IRING  
JS\_ICONNECT  
JS\_OCONNECT  
JS\_ERROR  
JS\_OFFLINE  
JS\_BUSY  
JS\_RBUSY  
JS\_INUSE  
JS\_DISCONNECTED  
JS\_HOLD  
JS\_ONHOLD  
JS\_HOLDNONHOLD  
JS\_ORINGHOLD  
JS\_OCALLHOLD  
JS\_RBUSYHOLD  
JS\_OCONNECTHOLD  
JS\_OGMRCV  
JS\_OVMAILRECWAIT  
JS\_OVMAILREC  
JS\_OVMAILXMT  
JS\_OVMAILPLAY  
JS\_OVMAILPAUSE  
JS\_OGMPLAY  
JS\_IVMAILRECWAIT  
JS\_IVMAILREC  
JS\_CAMPACK  
JS\_FILEXMT  
JS\_FILEXMTACK  
JS\_FILERCV  
JS\_FILESND  
JS\_EMAILRCV  
JS\_INFOACK  
JS\_INFRCV  
JS\_OGMPAUSE  
JS\_OGMPLAY  
JS\_OGMREC  
JS\_VMAILPLAY  
JS\_VMAILPAUSE  
JS\_VMAILRCV  
JS\_EMAILFILERCV  
JS\_USERINFO

User Interface Events

Action	GUI event	PM event
open phone directory	press [DIR]	
open voice mail messages dialog	press [MSG]	
open activity log	press [LOG]	
open configuration control dialog	press [CFG]	
open data files dialog	press [DAT]	
open help system	press [?]   press ? in dialogs	
display bubble help	point to any [ ] [ ]v for 1.5 seconds	
display party information	rt clk on [n]  [Li]  [Lh]	
display camp list	rt clk on [CMP]	
display call block list	rt clk on [BLK]  [BLK]v	
display priority ring list	rt clk on [PRI]  [PRI]v	
display conference list	rt clk on [Ci]  [Ch]; press dn arrow in display	
save voice mail to file system	drag selected voice mail to dir in WFM	
save ogm to file system	drag selected ogms to dir in WFM	
restore voice mail from file system	drag selected .wpm files to Voice Mail dialg	
restore or add ogm from file system	drag selected ogms from dir in WFM to OGM dialog	
add party on line to phone directory	press [DIR]; drag [Li]  [Lh] to DIR	
add party on conf line to phone directory	rt clk [Ci]  [Ch]; press dn arrow, drag party to DIR	
assign party to speed dial	press [DIR];drag party to [n] where n != .	
"	drag [Li]  [Lh] to [n] where n != .	
place an IP based call	press [n];[n];...[n];[SND]	PM_IPCALL
place an e-mail or IP based call	name;[SND]	PM_CALL   PM_IPCALL
"	drag Party from DIR to [Lf]	"
"	press [DIR];dbl clk on party in DIR	"
recall the last party called	press [RCL]	"
"	drag [RCL] to [Lf]	"
speed dial	drag [n] to [Lf]	"
"	press [n];[SND]	"
call party from activity log	press [LOG]; dbl clk on log entry	"
"	drag log entry to [Lf]	"

CONFIDENTIAL INFORMATION

Figures 50-52

User Interface Events

Action	GUI event	PM event
answer a call	press [SND]	PM_ANSWER
"	press [Lc]	"
pre-select a line	press [Lf]	PM_SELECT, ON
deselect a line	press [Ls]	PM_SELECT, OFF
place a call on hold	press [Li][Ci]	PM_HOLD, ON
"	press [HLD]	"
"	press [Lx][Cx] where Lx != Li   Cx != Ci	"
"	press [RCL]	"
take a call off hold	press [Lh][Ch]	PM_HOLD, OFF
end a call	press [END]	PM_END
mute a line	press [MUT]	PM_MUTE, ON
take mute off a line	press [MUT]v	PM_MUTE, OFF
enable call blocking	press [BLK]	PM_BLK, ON
disable call blocking	press [BLK]v	PM_BLK, OFF
add party to call block list	update party in DIR   drag party to [BLK]	PM_UPDBLK,,, ADD
delete party from call block list	remove party from block list in display	PM_UPDBLK,,,DELETE
enable do not disturb	press [DND]	PM_DND, ON
disable do not disturb	press [DND]v	PM_DND, OFF
enable priority ringing	press [PRI]	PM_PRI, ON
disable priority ringing	press [PRI]v	PM_PRI, OFF
add party to priority ring list	update party in DIR	PM_UPDPRI,,, ADD
delete party from priority ring list	remove party from priority ring list in display	PM_UPDPRI,,,DELETE
camp on a busy or offline call	press [CMP]	PM_CAMP, line
remove camp on party	rt clk on [CMP]; delete party from camp list	
enable call forwarding	press [FWD]	PM_FWD, ON
disable call forwarding	press [FWD]v	PM_FWD, OFF
assign party to call forward	drag party in DIR[[Li][Lh]][n] to [FWD]	PM_FWD, *party
transfer a party to another line	drag [Li][Lh] to a [Lf]	PM_LINEXFR
add on or more parties to conference	drag [Li][Lh][Ci][Ch] to another [Li][Lh][Ci][Ch]	PM_CNFAADD (for each party)
transfer a party from a conf to a line	drag party from conf list to [Lf]	PM_CNFDROP
transfer a party from one conf to another	drag party from conf list to another [Ci][Ch]	PM_CNFDROP ; PM_CNFAADD
remove a party from a conference	select party in conf list and press [END]	PM_CNFDROP
start recording audio	press [*]	PM_ACREC
start playing audio	press [!>]	PM_ACPLAY

**User Interface Events**

Action	GUI event	PM event
stop rec or playing audio	press [stop]	PM_ACSTOP
pause rec or playing audio	press [  ]	PM_ACPAUSE
rewind audio to beginning	press [ <]	PM_ACRWD
fast forward audio to end	press [ >]	PM_ACFWD
cancel audio record session	press [x]	PM_ACABORT
finished recording voice mail	press [END]	PM_ACEND
finished recording ogm	select another ogm	"
play audio file to party on line	drag vmail from MSG to [Li][Lh][Ci][Ch]	PM_ACPLAY
"	drag ogm from OGM to [Li][Lh][Ci][Ch]	"
"	drag audio file from WFM to [Li][Lh][Ci][Ch]	"
transfer file(s) to one or more parties	drag file(s) from WFM to [Li][Lh][Ci][Ch]	PM_FILEXFR
"	drag file(s) from WFM to selected parties in DIR	"
abort file transfers	press [DAT]; select file in <i>Data Files Out</i> ; press [x]	PM_FILEXFRABORT
request directory assistance	bad name:[SND]   press [DIR];press [Info]	PM_INFOREQ
abort directory assistance request	press [x] in Information dialog	PM_INFOABORT

Key to symbols
[ ] = button is up
[ ]v = button is down
n = 0,1,2,3,4,5,6,7,8,9, .
L = single line (1 party)
C = conference line (> 1 party)
Lf = free line
Lc = call on line
Lh = hold on line
Li = in use line
Ls = selected line
; = then
= or
WFM = MS Windows File Manager

~~PM-TRAFFIC~~  
 PM\_SELECTFILE \*job \*file  
 UI Triggered PM Events

(Init Job so  
 wav file  
 is associated)

event	arg1	arg2	arg3	comment
PM_INIT				
PM_CLOSE				
PM_CALL	*job	lineID		initiate email call
PM_IPCALL	*job	lineID		initiate IP call
PM_ANSWER		lineID		answer received
PM_HOLD		lineID	ON   OFF	toggle hold
PM_SELECT		lineID	ON   OFF	toggle line selection
PM_END		lineID		end call
PM_MUTE		lineID	ON   OFF	toggle muting
PM_BLK			ON   OFF	toggle call block
PM_UPDBLK	*party		ADD   DELETE	add or del party from blk list
PM_DND			ON   OFF	toggle do not disturb
PM_FWD	*party		ON   OFF	arg1 or arg3
PM_CAMP	sid	lineID		sid - OFF   lineID - ON
PM_PRI			ON   OFF	toggle priority ringing
PM_UPDPRI	*party		ADD   DELETE	add or del party to priority ring list
PM_LINEXFR		lineID	lineID	lineIDs not the same
PM_CNFADD	partyID	lineID		add party to cnf
PM_CNFDROP	partyID	lineID		drop party from cnf
PM_PARTYXFR	partyID	lineID	lineID	lineIDs not the same
PM_INFOREQ	*job	char*		directory assistance request
PM_INFOABORT	*job			abort directory assistance
PM_FILEXFR	*job	char*		initiate file transfer
PM_FILEXFRABORT	*job			abort file transfer
PM_ACSTOP	*job			audio control stop
PM_ACPLAY	*job			audio control play
PM_ACPAUSE	*job			audio control pause
PM_ACREC	*job			audio control record
PM_ACABORT	*job			audio control cancel
PM_ACRWD	*job			audio control rewind
PM_ACFWD	*job			audio control forward
PM_ACEND	*job			psuedo-control: lose focus
PM_MIC	*job	*buf		microphone I/O
PM_SPKR	*job	*buf		speaker I/O
PM_SOCKET	*job	*buf	READ   WRITE	socket I/O
PM_TIMEOUT	*job		TM_?	timer elapsed

del

{

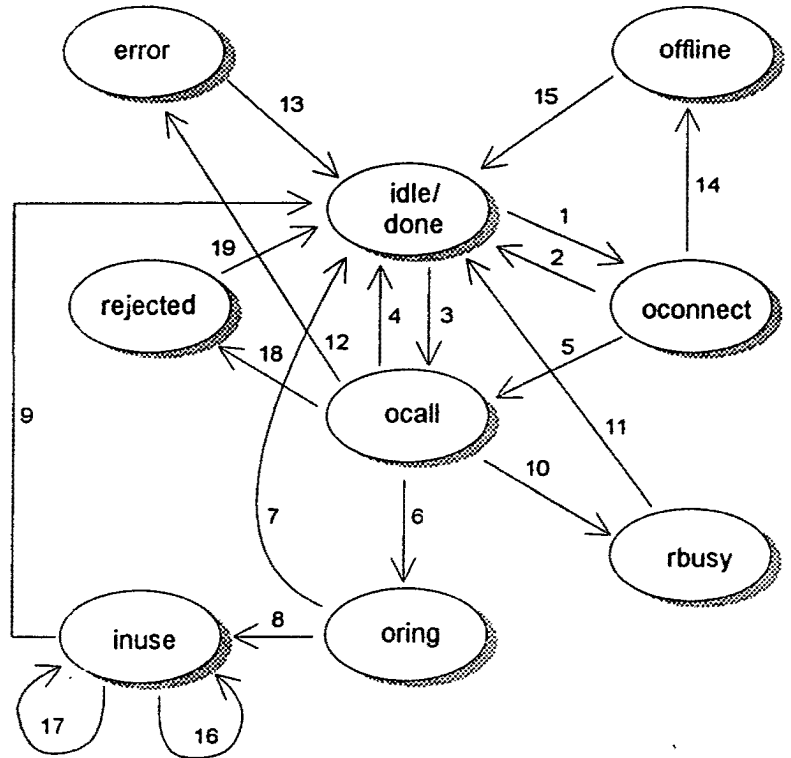
first 10  
 last 10  
 company 10  
 city 10  
 state 10  
 county 10  
 "in file"  
 "record"  
 search



PhoneManager State-Event Diagrams

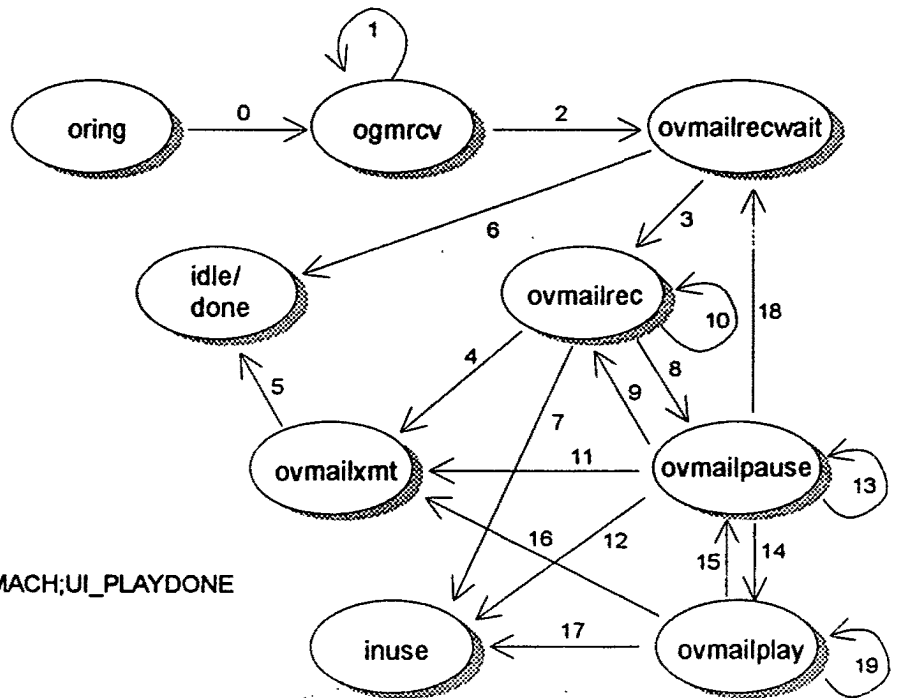
Placing a call events

1. PM\_CALL ; {CALL} ->
2. PM\_END
3. PM\_IPCALL | <- {CAMPCALL} ; <Call> ->
4. PM\_END
5. <- <ConnectOK> ; <Call> ->
6. <- <CallAck>;LS\_RINGOUT;UI\_CALLACK
7. PM\_END
8. <- <Answer>;LS\_INUSE;UI\_CALLANSWER
9. PM\_END | <- <End>;LS\_DONE;UI\_CALLEND
10. <- <Busy>;LS\_BUSY;UI\_CALLBUSY
11. PM\_END
12. PM\_TIMEOUT;LS\_COMMFAIL;UI\_COMMFAIL
13. PM\_END
14. PM\_TIMEOUT;LS\_OFFLINE;UI\_OFFLINE
15. PM\_END
16. PM\_SOCKET
17. PM\_MIC | PM\_SPKR
18. <- <Reject>;LS\_REJECTED;UI\_CALLREJECTED
19. PM\_END



Recording and sending vmail Events

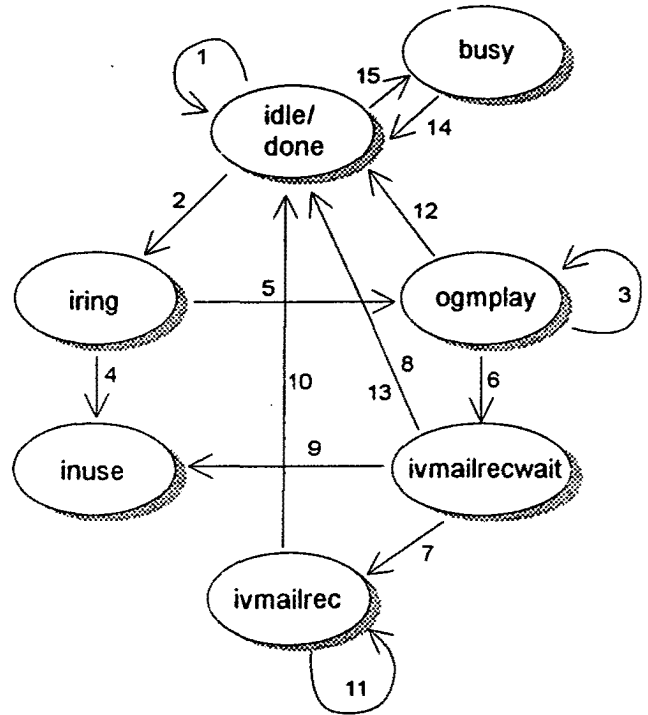
0. <- <AnsMachine>;LS\_ANSMACH;UI\_ANSMACH
1. PM\_SOCKET
2. <- <OgmEnd>;UI\_VMAILREC
3. PM\_ACREC
4. PM\_END
5. end of file;UI\_VMAILSENT
6. PM\_END
7. <- <Answer>;LS\_INUSE;UI\_CALLANSWER
8. PM\_ACPAUSE | PM\_ACSTOP
9. PM\_ACREC
10. PM\_MIC;AE\_USEME;UI\_AUDIOSTS
11. PM\_END
12. <- <Answer>;LS\_INUSE;UI\_CALLANSWER
13. PM\_ACRWD | PM\_ACFWD
14. PM\_ACPLAY
15. PM\_ACPAUSE | PM\_ACSTOP | end of file;LS\_ANSMACH;UI\_PLAYDONE
16. PM\_END
17. <- <Answer>;LS\_INUSE;UI\_CALLANSWER
18. PM\_ACABORT
19. PM\_SPKR;AE\_FILLME;UI\_AUDIOSTS



PhoneManager State-Event Diagrams

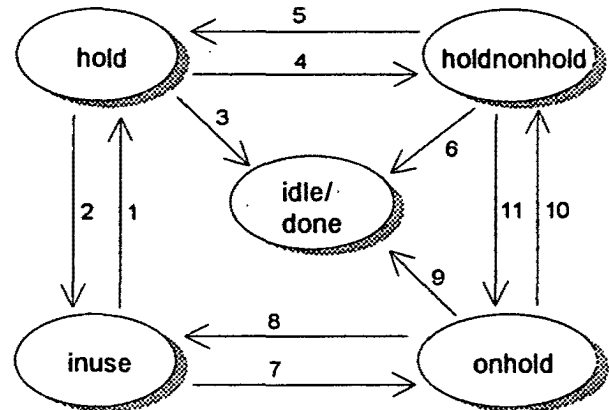
Inbound call and answering machine events

1. ← {CALL} ; <ConnectOK> →
2. ← <Call> ; <CallAck> →;LS\_CALL;UI\_CALL
3. <Audio> →
4. PM\_ANSWER ; <Answer> →
5. PM\_TIMEOUT ; <AnsMachine> →;LS\_OGMPLAY;UI\_OGMPLAY
6. end of file ; <OgmEnd> →;LS\_VMAILRCV;UI\_VMAILRCV
7. ← <Audio> ; AE\_START;LS\_DONE;UI\_CALLEND
8. ← <End>;LS\_DONE;UI\_CALLEND
9. PM\_ANSWER ; <Answer> →
10. ← <End> ; AE\_STOP;LS\_DONE;UI\_VMAILRCVD
11. PM\_SOCKET;AE\_USEME
12. ← <End>;LS\_DONE;UI\_CALLEND
13. ← <Camp>;UI\_CAMPRCV
14. ← <End>|PM\_TIMEOUT|← <Camp>;UI\_CAMPRCV
15. ← <Call> w/ NO AVAIL LINES & ANSMACH disabled



Hold events

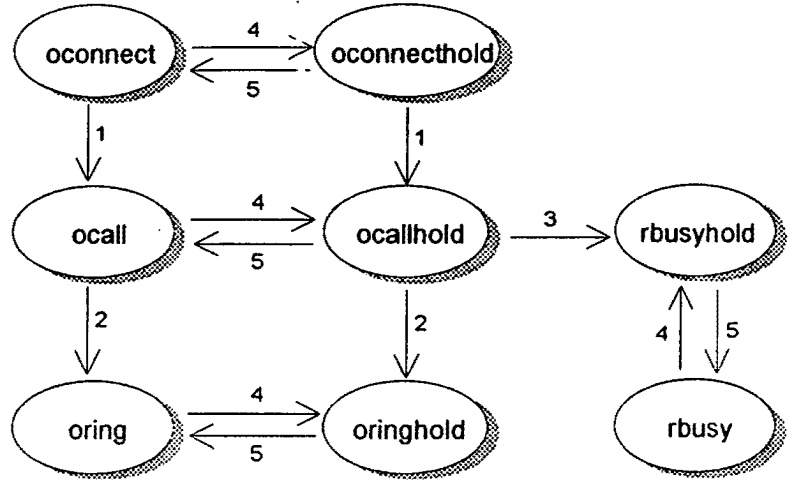
1. PM\_HOLD, ON
2. PM\_HOLD, OFF
3. PM\_END ; ← <End>;LS\_DONE;UI\_CALLEND
4. ← <Hold, ON>;LS\_ONHOLD;UI\_ONHOLD
5. ← <Hold, OFF>;LS\_OFFHOLD;UI\_OFFHOLD
6. PM\_END, ← <End>;LS\_DONE;UI\_CALLEND
7. ← <Hold, ON>;LS\_ONHOLD;UI\_ONHOLD
8. ← <Hold, OFF>;LS\_OFFHOLD;UI\_OFFHOLD
9. PM\_END, ← <End>;LS\_DONE;UI\_CALLEND
10. PM\_HOLD, ON
11. PM\_HOLD, OFF



PhoneManager State-Event Diagrams

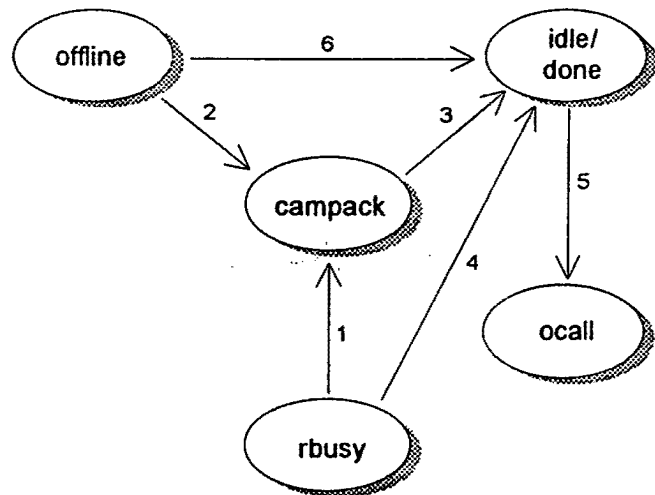
More hold events

- 1. ← <ConnectOK> ; <Call> →
- 2. ← <CallAck>;UI\_CALLACK
- 3. ← <Busy>;LS\_RBUSY;UI\_CALLBUSY
- 4. PM\_HOLD, ON
- 5. PM\_HOLD, OFF



Camping events

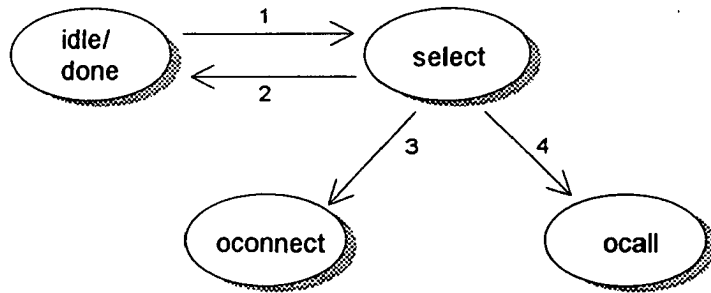
- 1. PM\_CAMP,line ; <Camp> →
- 2. PM\_CAMP, line ; {CAMPCALL} →
- 3. ← <CampAck> ; LS\_CAMPACK;UI\_CAMPACK
- 4. PM\_END; <End> →
- 5. PM\_IPCALL ; <Call> →
- 6. PM\_END



PhoneManager State-Event Diagrams

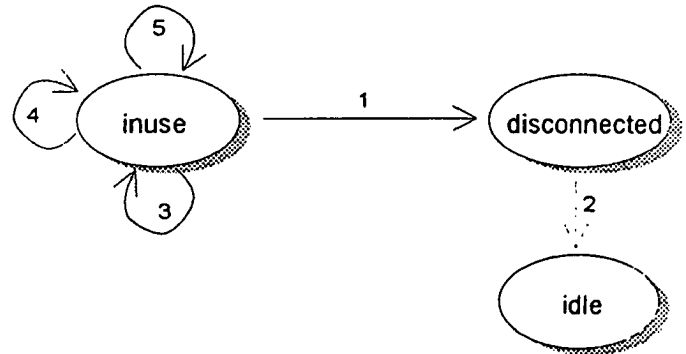
Select events

1. PM\_SELECT, ON
2. PM\_SELECT, OFF
3. PM\_CALL
4. PM\_IPCALL



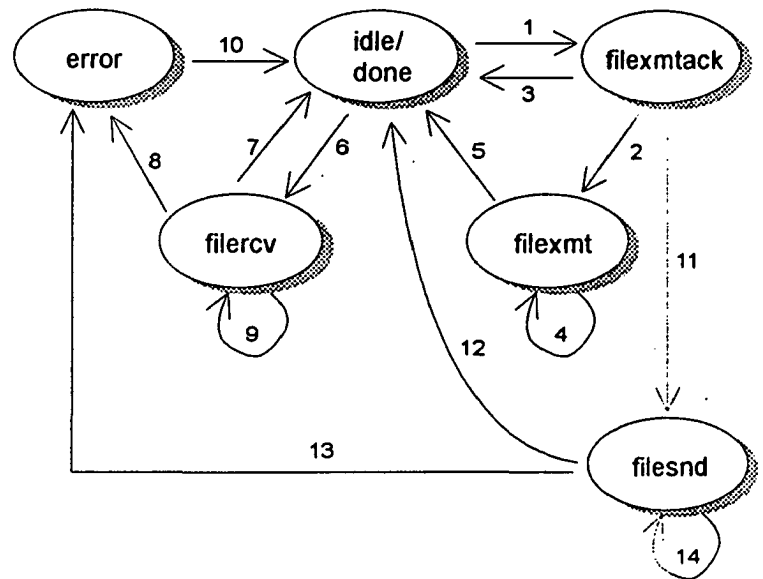
Hello events

1. PM\_TIMEOUT, ihello
2. PM\_END
3. <Hello> | PM\_SOCKET, READ ; TM\_IHELLO
4. PM\_TIMEOUT, ohello ; <Hello> ->
5. PM\_MIC | PM\_SOCKET, WRITE ; TM\_OHELLO



File transfer events

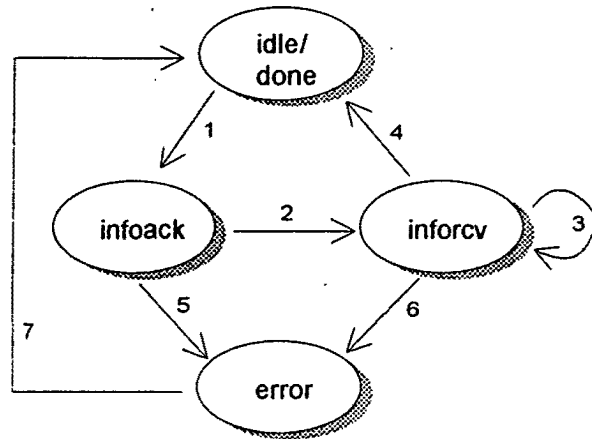
1. PM\_FILEXFR ; <FileXmtReq> ->
2. <- <FileXmtAck>
3. PM\_FILEXFRABORT ; <Filexfrabort> ->
4. <File> -> ; UI\_FILEXFRSTS
5. end of file ; <FileXmtEnd> -> ; UI\_FILEXFRSTS
6. <- <FileXmtReq> ; <FileXmtAck> ->
7. <- <FileXmtAbort> | <- <FileXmtEnd> ; UI\_FILEXFREND
8. PM\_TIMEOUT, file
9. <- <File>
10. job.state = LS\_ERROR ; UI\_FILEXFRFAILURE
11. PM\_TIMEOUT, filexmtack
12. end of file ; UI\_FILEXFREND
13. failure to email
14. {FILEXFR} -> ; UI\_FILEXFRSTS



PhoneManager State-Event Diagrams

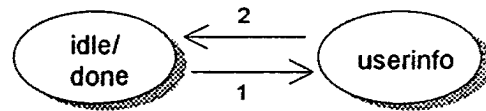
Directory assistance events

1. PM\_INFOREQ; <InfoReq> ->
2. <- <InfoAck>;UI\_INFOACK
3. <- <Info>;UI\_INFO
4. <- <InfoEnd>;UI\_INFOEND
5. PM\_TIMEOUT, infoack;UI\_INFOFAILURE
6. PM\_TIMEOUT, info;UI\_INFOFAILURE
7. job.state = LS\_ERROR



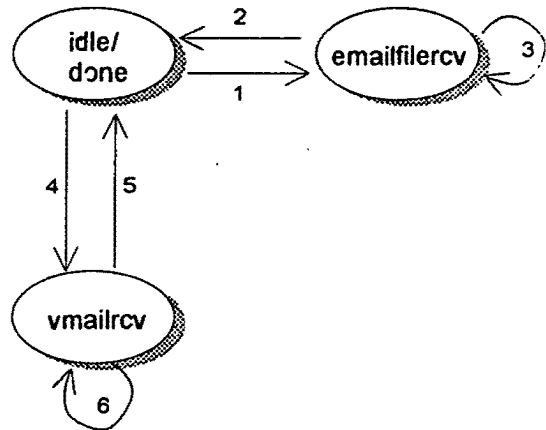
Operator initiated user info acquisition

1. <- <Userinfo> ->
2. <Userinforeq>



Receive Vmail, Email & Files via POP

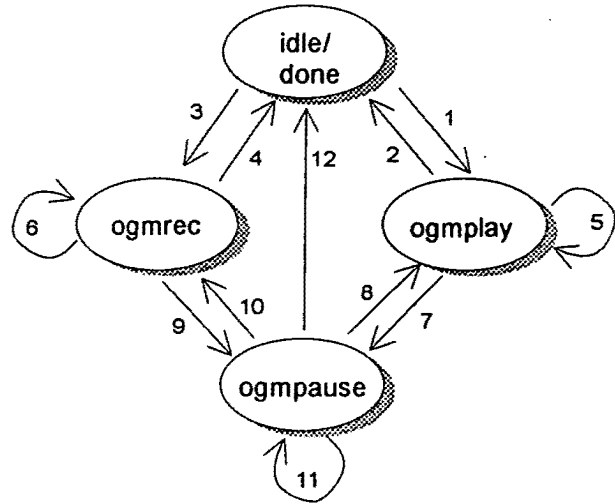
1. <- {EMAIL} | <- {FILEXFR}
2. end of file;UI\_FILEXFREND
3. read chunk-o-file;UI\_FILEXFRSTS
4. <- {VMAIL}
5. end of file;UI\_VMAILRCVD
6. read chunk-o-vmail



PhoneManager State-Event Diagrams

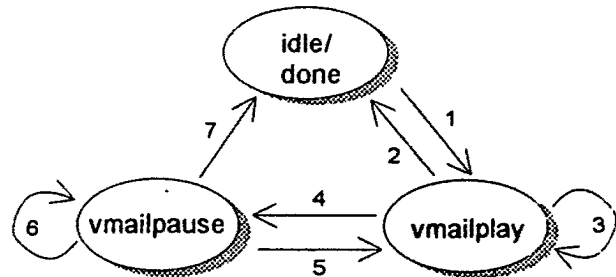
Recording and playing OGMs

1. PM\_ACPLAY
2. PM\_ACABORT
3. PM\_ACREC
4. PM\_ACABORT
5. PM\_SPKR;AE\_FILLME;UI\_AUDIOSTS
6. PM\_MIC;AE\_USEME;UI\_AUDIOSTS
7. PM\_ACPAUSE|PM\_ACSTOP|end of file
8. PM\_ACPLAY
9. PM\_ACPAUSE|PM\_ACSTOP|rec file full
10. PM\_ACREC
11. PM\_ACRWD | PM\_ACFWD
12. PM\_ACABORT



Playing Vmail

1. PM\_ACPLAY
2. PM\_ACEND | lost focus
3. PM\_SPKR;AE\_FILLME;UI\_AUDIOSTS
4. PM\_ACPAUSE | PM\_ACSTOP
5. PM\_PLAY
6. PM\_ACRWD | PM\_ACFWD
7. PM\_ACEND | lost focus



PM triggered UI Events

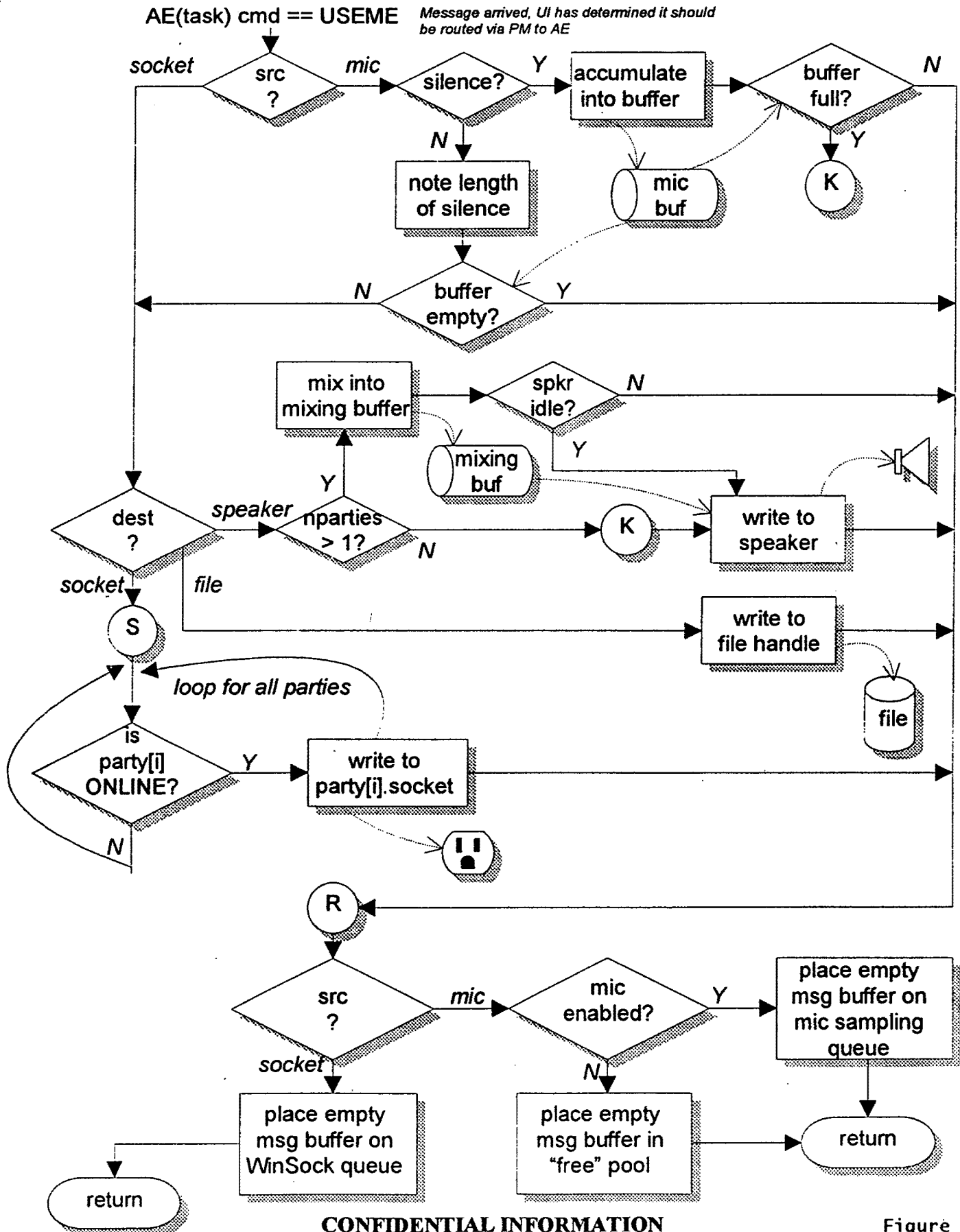
event	arg1	arg2	UI actions
UI_CAMPACK	lineID		LED:blink blue-green;play <i>campack.wav</i>
UI_CAMPRCV		*job	upd camp.lst;upd camp list memory image
UI_CALL	lineID		annunc:"CALL";play <i>ringin.wav</i> ; chg LED
UI_CALLACK	lineID		annunc:"RINGING";play <i>ringout.wav</i> ; chg LED
UI_CALLANSWER	lineID		stop play; annunc:"INUSE"; chg LED
UI_CALLEND	lineID		annunc:"IDLE";chg LED
UI_CALLBUSY	lineID		annunc:"BUSY";play <i>busy.wav</i> ; chg LED
UI_CALLOFFLINE	lineID		stop play;annunc:"OFFLINE";chg LED
UI_CALLOHHOLD	lineID		annunc:"ON HOLD";chg LED
UI_CALLOFFHOLD	lineID		annunc:"IN USE";chg LED
UI_COMMFAIL	lineID		annunc:"COMMUNICATIONS FAILURE";chg LED
UI_CALLREJECT	lineID		annunc:"CALL REJECTED";chg LED
UI_ANSMACHINE	lineID		annunc:"ANSWERING MACHINE"
UI_VMAILREC	lineID		activate audio controls
UI_VMAILSENT		*job	remove vmail xmt annunciator icon
UI_VMAILRCV	lineID		annunc:"RECEIVING VOICE MAIL"
UI_VMAILRCVD		*job	annunc:upd vmail msg count; upd MSG dialog
UI_FILEXFRSTS		*job	DAT:upd file xfr progress bar
UI_FILEXFREND		*job	DAT:upd file xfr progress bar;upd files.dir; remove file xmt annunc icon
UI_FILEXFRABORT		*job	DAT:say"TRANSFER ABORTED" in prog bar;remove file xmt annunc icon
UI_FILEXFRFAIL		*job	DAT:say"COMMUNICATIONS FAILURE" in prog bar; remove file xmt annunc icon
UI_AUDIOSTS		*job	update audio control progress bar
UI_PLAYDONE	lineID		annunc:"ANSWERING MACHINE"
UI_OGMPPLAY	lineID		annunc:"PLAYING OUTGOING MESSAGE"
UI_INFOACK		*job	upd directory assistance dialog
UI_INFO		*job	upd directory assistance dialog: update progress bar
UI_INFOEND		*job	upd directory assistance dialog
UI_INFOFAIL		*job	upd directory assistance dialog: say"COMMUNICATIONS FAILURE" in prog bar

UI-START #records  
 UI-INFOREC direct  
 UI-INFOFAIL

Directory Assistance not Available

NOTE: if job.state = JS\_DONE, the UI must remove the job after the action is performed!

Audio Engine Logic Flow

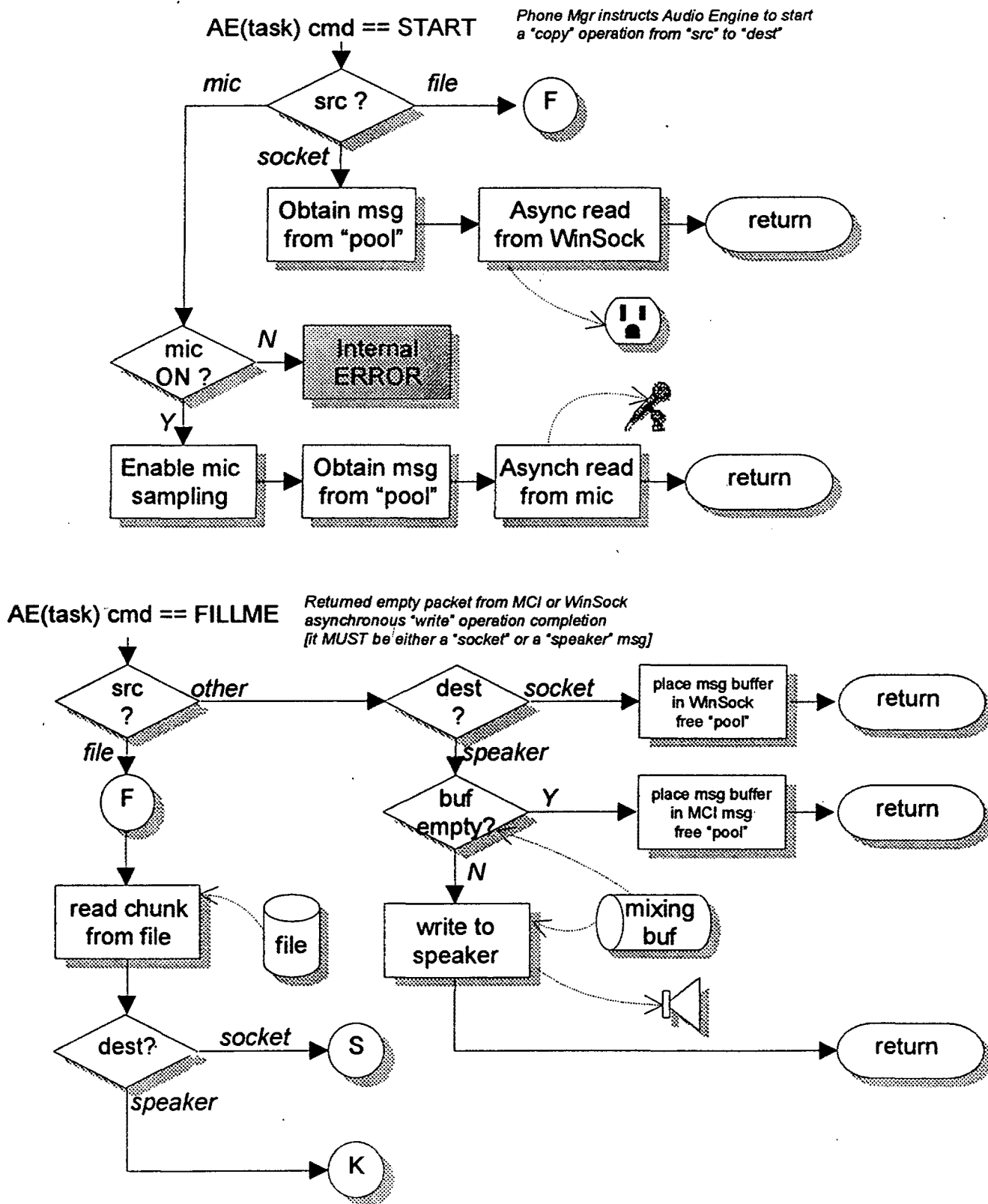


CONFIDENTIAL INFORMATION

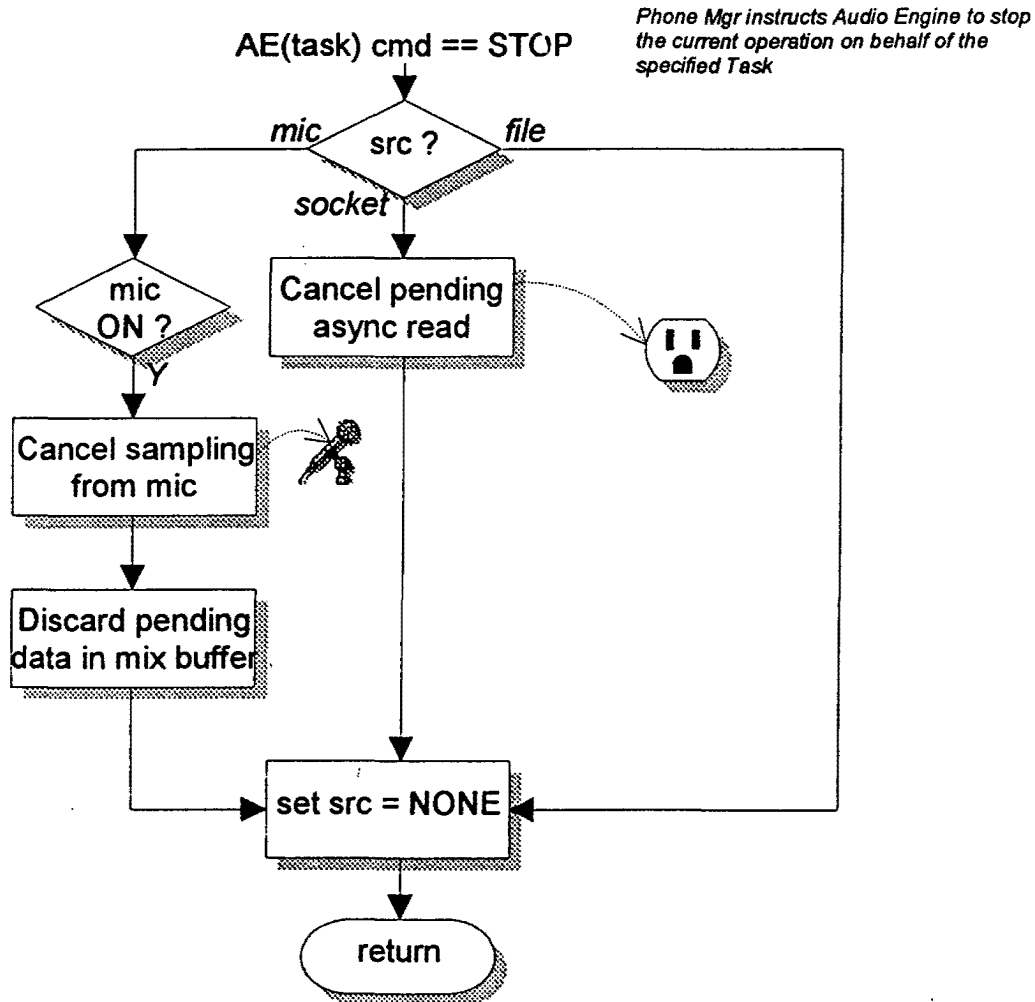
Figure 61



### Audio Engine Logic Flow

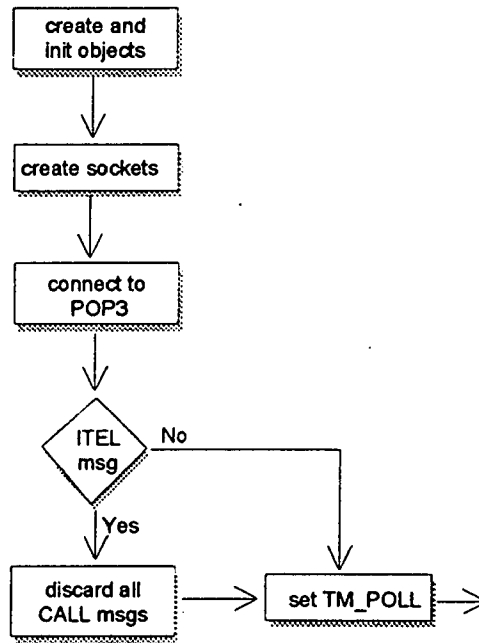


### Audio Engine Logic Flow

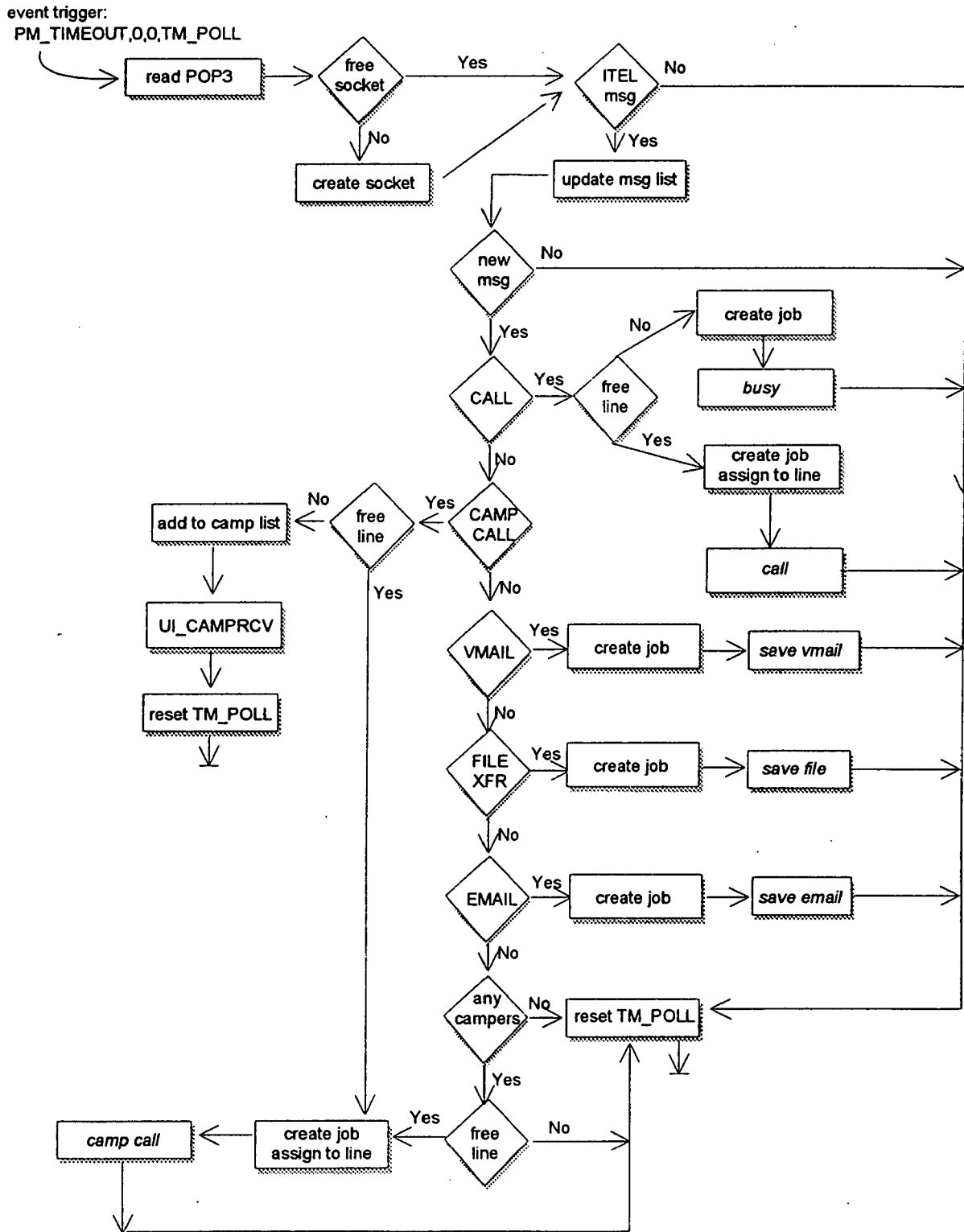


### PhoneManager Init Function

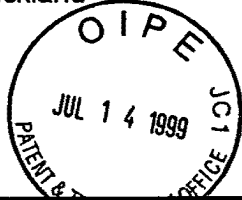
event trigger: PM\_INIT



PhoneManager Polling Function



#32  
8.30nd

<b>SUPPLEMENTAL DECLARATION (37 C.F.R. §1.63)</b>	Docket No.: N0003/7000
Applicant: Glenn W. Hutton, Shane D. Mattaway and Craig B. Strickland Serial No 08/533,115 Filed: September 25, 1995 For: POINT-TO-POINT INTERNET PROTOCOL Examiner: M.H. Rinehart Art Unit: 2756	

As a below-named inventor, I hereby declare that:

1. My residence, post-office address and citizenship are as stated below next to my name.
2. I believe I am the original, first and sole inventor (if only one name is listed below) or an original, first and joint inventor (if plural names are listed below) of the subject matter which is disclosed and claimed in the above-identified application for patent as amended on April 5, 1996, December 2, 1997 and March 1, 1999.
3. I have reviewed and understand the contents of the above-identified application specification, as amended, including the claims.
4. I acknowledge the duty to disclose all information known to me that is material to patentability as defined in 37 C.F.R. §1.56.

5. I hereby claim foreign priority benefits under 35 U.S.C. §119(a)-(d) or 365(b) of any foreign application(s) for patent or inventor's certificate or 365(a) of any PCT application which designated at least one country other than the United States of America, listed below and have also identified below, by checking the appropriate box, any foreign application for patent or inventor's certificate, or any PCT international application having a filing date before that of the application on which priority is claimed:

Application No.	Country	Filing Date	Priority NOT Claimed	Certified Copy Attached.
			<input type="checkbox"/>	<input type="checkbox"/>

Additional foreign application numbers are listed on a supplemental priority data sheet attached hereto

6. I hereby claim the benefit under 35 U.S.C. §119(e) of any United States provisional applications listed below:

Application No.	Filing Date

Additional provisional application numbers are listed on a supplemental data sheet attached hereto

7. I hereby claim the benefit under 35 U.S.C. §120, of the United States Application(s) or 365(c) of any PCT international application designating the United States of America, listed below and, insofar as the subject matter of each of the claims of this application is not disclosed in the prior United States or PCT international application in the manner provided by the first paragraph of 35 U.S.C. §112, I acknowledge the duty to disclose all

information which is material to patentability as defined in 37 C.F.R. §1.56, and which became available to me between the filing date of the prior application and the national or PCT international filing date of this application:

Application No.                      Filing Date                      Parent Patent No.

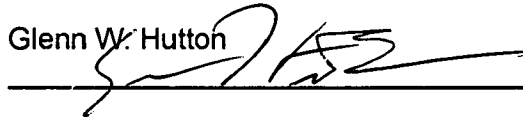
Additional U.S. or PCT application numbers are listed on a supplemental data sheet attached hereto

---

I hereby declare that all statements made herein of my own knowledge are true and that all statements made on information and belief are believed to be true; and further that these statements were made with the knowledge that willful false statements and the like so made are punishable by fine or imprisonment or both under 18 U.S.C. §1001 and that such willful false statements may jeopardize the validity of the application or any patent issued thereon.

First Inventor Name:  
Inventor's Signature:

Glenn W. Hutton

 Date: 7-6-99

Citizenship:  
Residence Address:  
Post Office Address:

Canada  
6450 SW 100<sup>th</sup> Street Pinecrest Florida 33156  
6450 SW 100<sup>th</sup> Street Pinecrest Florida 33156

Second Inventor Name: Shane D. Mattaway

Inventor's Signature:

\_\_\_\_\_ Date: \_\_\_\_\_

Citizenship:  
Residence Address:  
Post Office Address:

U.S.A.  
826 Periwinkle Street, Boca Raton, FL 33486  
826 Periwinkle Street, Boca Raton, FL 33486

Additional inventors are being named on the additional inventor sheet attached hereto.

**DECLARATION - SUPPLEMENTAL INVENTOR SHEET**

**Third Inventor Name:** Craig B. Strickland

**Inventor's Signature:** \_\_\_\_\_ **Date:** \_\_\_\_\_

**Citizenship:** Canada

**Residence Address:** 5713 NW 65th Terrace, Tamarac, Florida

**Post Office Address:** 5713 NW 65th Terrace, Tamarac, Florida

<b>SUPPLEMENTAL DECLARATION (37 C.F.R. §1.63)</b>		Docket No.: N0003/7000
Applicant:	Glenn W. Hutton, Shane D. Mattaway and Craig B. Strickland	
Serial No	08/533,115	
Filed:	September 25, 1995	
For:	POINT-TO-POINT INTERNET PROTOCOL	
Examiner:	M.H. Rinehart	
Art Unit:	2756	



As a below-named inventor, I hereby declare that:

1. My residence, post-office address and citizenship are as stated below next to my name.
2. I believe I am the original, first and sole inventor (if only one name is listed below) or an original, first and joint inventor (if plural names are listed below) of the subject matter which is disclosed and claimed in the above-identified application for patent as amended on April 5, 1996, December 2, 1997 and March 1, 1999.
3. I have reviewed and understand the contents of the above-identified application specification, as amended, including the claims.
4. I acknowledge the duty to disclose all information known to me that is material to patentability as defined in 37 C.F.R. §1.56.

5. I hereby claim foreign priority benefits under 35 U.S.C. §119(a)-(d) or 365(b) of any foreign application(s) for patent or inventor's certificate or 365(a) of any PCT application which designated at least one country other than the United States of America, listed below and have also identified below, by checking the appropriate box, any foreign application for patent or inventor's certificate, or any PCT international application having a filing date before that of the application on which priority is claimed:

Application No.	Country	Filing Date	Priority NOT Claimed	Certified Copy Attached.
			<input type="checkbox"/>	<input type="checkbox"/>

Additional foreign application numbers are listed on a supplemental priority data sheet attached hereto

6. I hereby claim the benefit under 35 U.S.C. §119(e) of any United States provisional applications listed below:

Application No.	Filing Date

Additional provisional application numbers are listed on a supplemental data sheet attached hereto

7. I hereby claim the benefit under 35 U.S.C. §120, of the United States Application(s) or 365(c) of any PCT international application designating the United States of America, listed below and, insofar as the subject matter of each of the claims of this application is not disclosed in the prior United States or PCT international application in the manner provided by the first paragraph of 35 U.S.C. §112, I acknowledge the duty to disclose all



information which is material to patentability as defined in 37 C.F.R. §1.56, and which became available to me between the filing date of the prior application and the national or PCT international filing date of this application:

Application No.                      Filing Date                      Parent Patent No.

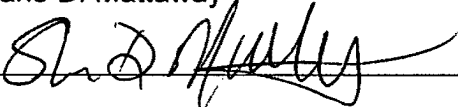
Additional U.S. or PCT application numbers are listed on a supplemental data sheet attached hereto

---

**I hereby declare that all statements made herein of my own knowledge are true and that all statements made on information and belief are believed to be true; and further that these statements were made with the knowledge that willful false statements and the like so made are punishable by fine or imprisonment or both under 18 U.S.C. §1001 and that such willful false statements may jeopardize the validity of the application or any patent issued thereon.**

**First Inventor Name:** Glenn W. Hutton  
Inventor's Signature: \_\_\_\_\_ Date: \_\_\_\_\_

Citizenship: Canada  
Residence Address: 9725 Hammocks Boulevard, #206, Miami, Florida 33196  
Post Office Address: 9725 Hammocks Boulevard, #206, Miami, Florida 33196

**Second Inventor Name:** Shane D. Mattaway  
Inventor's Signature:  Date: 6/30/99

Citizenship: U.S.A.  
Residence Address: 826 Periwinkle Street, Boca Raton, FL 33486  
Post Office Address: 826 Periwinkle Street, Boca Raton, FL 33486


Additional inventors are being named on the additional inventor sheet attached hereto.

**DECLARATION - SUPPLEMENTAL INVENTOR SHEET**

**Third Inventor Name:** Craig B. Strickland

**Inventor's Signature:** \_\_\_\_\_ **Date:** \_\_\_\_\_

**Citizenship:** Canada  
**Residence Address:** 5713 NW 65th Terrace, Tamarac, Florida  
**Post Office Address:** 5713 NW 65th Terrace, Tamarac, Florida

<b>SUPPLEMENTAL DECLARATION (37 C.F.R. §1.63)</b>	Docket No.: N0003/7000
Applicant: Glenn W. Hutton, Shane D. Mattaway and Craig B. Strickland Serial No 08/533,115 Filed: September 25, 1995 For: POINT-TO-POINT INTERNET PROTOCOL Examiner: M.H. Rinehart Art Unit: 2756	

As a below-named inventor, I hereby declare that:

1. My residence, post-office address and citizenship are as stated below next to my name.
2. I believe I am the original, first and sole inventor (if only one name is listed below) or an original, first and joint inventor (if plural names are listed below) of the subject matter which is disclosed and claimed in the above-identified application for patent as amended on April 5, 1996, December 2, 1997 and March 1, 1999.
3. I have reviewed and understand the contents of the above-identified application specification, as amended, including the claims.
4. I acknowledge the duty to disclose all information known to me that is material to patentability as defined in 37 C.F.R. §1.56.

5. I hereby claim foreign priority benefits under 35 U.S.C. §119(a)-(d) or 365(b) of any foreign application(s) for patent or inventor's certificate or 365(a) of any PCT application which designated at least one country other than the United States of America, listed below and have also identified below, by checking the appropriate box, any foreign application for patent or inventor's certificate, or any PCT international application having a filing date before that of the application on which priority is claimed:

Application No.	Country	Filing Date	Priority NOT Claimed	Certified Copy Attached.
			<input type="checkbox"/>	<input type="checkbox"/>

Additional foreign application numbers are listed on a supplemental priority data sheet attached hereto

6. I hereby claim the benefit under 35 U.S.C. §119(e) of any United States provisional applications listed below:

Application No.	Filing Date

Additional provisional application numbers are listed on a supplemental data sheet attached hereto

7. I hereby claim the benefit under 35 U.S.C. §120, of the United States Application(s) or 365(c) of any PCT international application designating the United States of America, listed below and, insofar as the subject matter of each of the claims of this application is not disclosed in the prior United States or PCT international application in the manner provided by the first paragraph of 35 U.S.C. §112, I acknowledge the duty to disclose all

information which is material to patentability as defined in 37 C.F.R. §1.56, and which became available to me between the filing date of the prior application and the national or PCT international filing date of this application:

Application No.                      Filing Date                      Parent Patent No.

Additional U.S. or PCT application numbers are listed on a supplemental data sheet attached hereto

---

**I hereby declare that all statements made herein of my own knowledge are true and that all statements made on information and belief are believed to be true; and further that these statements were made with the knowledge that willful false statements and the like so made are punishable by fine or imprisonment or both under 18 U.S.C. §1001 and that such willful false statements may jeopardize the validity of the application or any patent issued thereon.**

**First Inventor Name:** Glenn W. Hutton  
**Inventor's Signature:** \_\_\_\_\_ **Date:** \_\_\_\_\_

**Citizenship:** Canada  
**Residence Address:** 9725 Hammocks Boulevard, #206, Miami, Florida 33196  
**Post Office Address:** 9725 Hammocks Boulevard, #206, Miami, Florida 33196

**Second Inventor Name:** Shane D. Mattaway

**Inventor's Signature:** \_\_\_\_\_ **Date:** \_\_\_\_\_

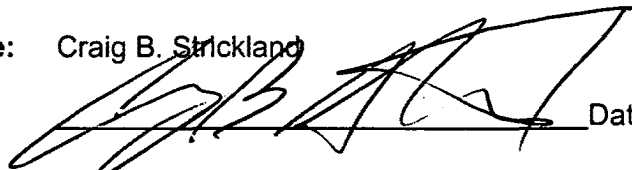
**Citizenship:** U.S.A.  
**Residence Address:** 826 Periwinkle Street, Boca Raton, FL 33486  
**Post Office Address:** 826 Periwinkle Street, Boca Raton, FL 33486

Additional inventors are being named on the additional inventor sheet attached hereto.

**DECLARATION - SUPPLEMENTAL INVENTOR SHEET**

**Third Inventor Name:** Craig B. Strickland

**Inventor's Signature:**



**Date:** 06/14/99

**Citizenship:**

Canada

**Residence Address:**

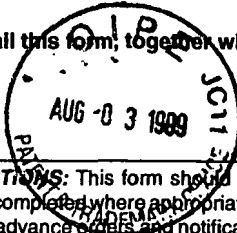
5713 NW 65th Terrace, Tamarac, Florida

**Post Office Address:**

5713 NW 65th Terrace, Tamarac, Florida

Complete and mail this form, together with applicable fees, to:

Box ISSUE FEE  
Assistant Commissioner for Patents  
Washington, D.C. 20231



**MAILING INSTRUCTIONS:** This form should be used for transmitting the ISSUE FEE. Blocks 1 through 4 should be completed where appropriate. All further correspondence including the Issue Fee Receipt, the Patent, advance orders and notification of maintenance fees will be mailed to the current correspondence address as indicated unless corrected below or directed otherwise in Block 1, by (a) specifying a new correspondence address; and/or (b) indicating a separate "FEE ADDRESS" for maintenance fee notifications.

CURRENT CORRESPONDENCE ADDRESS (Note: Legibly mark-up with any corrections or use Block 1)

021127  
KUDIRKA & JOBSE  
TWO CENTER PLAZA  
BOSTON MA 02108

LN51/0525

Note: The certificate of mailing below can only be used for domestic mailings of the Issue Fee Transmittal. This certificate cannot be used for any other accompanying papers. Each additional paper, such as an assignment or formal drawing, must have its own certificate of mailing.

**Certificate of Mailing**

I hereby certify that this Issue Fee Transmittal is being deposited with the United States Postal Service with sufficient postage for first class mail in an envelope addressed to the Box Issue Fee address above on the date indicated below.

Frances M. Cunningham (Depositor's name)  
*Frances M. Cunningham* (Signature)  
August 3, 1999 (Date)

APPLICATION NO.	FILING DATE	TOTAL CLAIMS	EXAMINER AND GROUP ART UNIT	DATE MAILED
08/533,115	09/25/95	044	RINEHART, M 2756	05/25/99
First Named Applicant	HUTTON,		35 USC 154(b) term ext. =	0 Days.

TITLE OF INVENTION: POINT-TO-POINT INTERNET PROTOCOL

ATTYS DOCKET NO.	CLASS-SUBCLASS	BATCH NO.	APPLN. TYPE	SMALL ENTITY	FEE DUE	DATE DUE
2 649-2	709-227.000	T56	UTILITY	YES	\$605.00	08/25/99

1. Change of correspondence address or indication of "Fee Address" (37 CFR 1.363). Use of PTO form(s) and Customer Number are recommended, but not required.

- Change of correspondence address (or Change of Correspondence Address form PTO/SB/122) attached.
- "Fee Address" indication (or "Fee Address" Indication form PTO/SB/47) attached.

2. For printing on the patent front page, list (1) the names of up to 3 registered patent attorneys or agents OR, alternatively, (2) the name of a single firm (having as a member a registered attorney or agent) and the names of up to 2 registered patent attorneys or agents. If no name is listed, no name will be printed.

- 1 Kudirka & Jobse, LLP
- 2 \_\_\_\_\_
- 3 \_\_\_\_\_

3. ASSIGNEE NAME AND RESIDENCE DATA TO BE PRINTED ON THE PATENT (print or type)  
**PLEASE NOTE:** Unless an assignee is identified below, no assignee data will appear on the patent. Inclusion of assignee data is only appropriate when an assignment has been previously submitted to the PTO or is being submitted under separate cover. Completion of this form is NOT a substitute for filing an assignment.

(A) NAME OF ASSIGNEE

**NetSpeak Corporation**

(B) RESIDENCE: (CITY & STATE OR COUNTRY)

**Boca Raton, Florida**

Please check the appropriate assignee category indicated below (will not be printed on the patent)

- Individual
- corporation or other private group entity
- government

4a. The following fees are enclosed (make check payable to Commissioner of Patents and Trademarks):

- Issue Fee
- Advance Order - # of Copies 10

4b. The following fees or deficiency in these fees should be charged to:

- DEPOSIT ACCOUNT NUMBER \_\_\_\_\_
- (ENCLOSE AN EXTRA COPY OF THIS FORM)
- Issue Fee
- Advance Order - # of Copies \_\_\_\_\_

The COMMISSIONER OF PATENTS AND TRADEMARKS IS requested to apply the Issue Fee to the application identified above.

(Authorized Signature)

*Burd D. Johnson*

(Date)

8/3/99

NOTE: The Issue Fee will not be accepted from anyone other than the applicant; a registered attorney or agent; or the assignee or other party in interest as shown by the records of the Patent and Trademark Office.

**Burd Hour Statement:** This form is estimated to take 0.2 hours to complete. Time will vary depending on the needs of the individual case. Any comments on the amount of time required to complete this form should be sent to the Chief Information Officer, Patent and Trademark Office, Washington, D.C. 20231. DO NOT SEND FEES OR COMPLETED FORMS TO THIS ADDRESS. SEND FEES AND THIS FORM TO: Box Issue Fee, Assistant Commissioner for Patents, Washington D.C. 20231

Under the Paperwork Reduction Act of 1995, no persons are required to respond to a collection of information unless it displays a valid OMB control number.

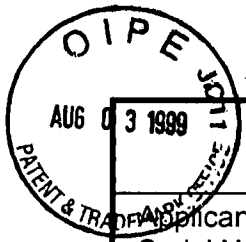
RECEIVED

AUG 06 1999

Publishing Division  
16

08/05/1999 TTRAH2 00000016 08533115  
 30.00 OF  
 1210.00 OF  
 01 FC:561  
 02 FC:142

TRANSMIT THIS FORM WITH FEE



B \$

<b>ISSUE FEE TRANSMITTAL</b>		Docket No. N0003/7000
Applicant:	Glenn W. Hutton, et al.	
Serial No.	08/533,115	
Filed:	September 25, 1995	
For:	METHOD AND APPARATUS FOR ESTABLISHING POINT-TO-POINT COMMUNICATIONS OVER A COMPUTER NETWORK	
Examiner:	M. Rinehart	
Art Unit:	2756	

**CERTIFICATE OF EXPRESS MAILING**

"Express Mail" mailing label number: EL445948657US  
Date of Deposit: August 3, 1999

I hereby certify that the following Correspondence is being deposited with the United States Postal Service "Express Mail Post Office to Addressee" service pursuant to 37 C.F.R. §1.10 on the date indicated above in an envelope addressed to Commissioner of Patents and Trademarks, BOX ISSUE FEE, Washington, D.C. 20231.

*Frances M. Cunningham*  
Frances M. Cunningham

Assistant Commissioner for Patents  
Box Issue Fee  
Washington, D.C. 20231

In response to the Notice of Allowance and Base Issue Fee Due dated May 25, 1999 for the above-identified application, enclosed are the following documents (indicated by a checked box):

**Documents**

- Issue Fee Transmittal
- Advance order of 10 soft copies of letters patent

**Small Entity**

- A small entity statement under 37 C.F.R. §1.27 has already been filed.
- A small entity statement under 37 C.F.R. §1.27 is attached.
- Small entity status is no longer claimed.

**Payment**

- A check in the amount of **\$1,240.00** is enclosed to cover the issue fee due and advance order of patent copies.
- The Commissioner is hereby authorized to charge any fees under 37 C.F.R. 1.16-1.19 to Deposit Account No. 02-3038. A duplicate of this sheet is attached.

*Bruce D. Jobse*  
\_\_\_\_\_  
Bruce D. Jobse, Esq. Reg. No. 33,518  
KUDIRKA & JOBSE, LLP  
Customer Number 021127  
Tel: (617) 367-4600 Fax: (617) 367-4656

Date: 8/3/99



**UNITED STATES DEPARTMENT OF COMMERCE  
Patent and Trademark Office**

Address: COMMISSIONER OF PATENTS AND TRADEMARKS  
Washington, D.C. 20231

*nw*

APPLICATION NO.	FILING DATE	FIRST NAMED INVENTOR	ATTORNEY DOCKET NO.
08/533,115	09/25/95	MUTTON	345-2

021127  
KUDIRKA & JOBSE  
TWO CENTER PLAZA  
BOSTON MA 02108

LM02/0308

EXAMINER RINELZARI, M
--------------------------

ART UNIT 2722	PAPER NUMBER
------------------	--------------

DATE MAILED: 03/08/00

*36*


**Please find below and/or attached an Office communication concerning this application or proceeding.**

**Commissioner of Patents and Trademarks**



**Response to Rule 312  
Communication**


Application No. <b>08/533,115</b>	Applicant(s) <b>Hutton et al.</b>
Examiner <b>Mark Rinehart</b>	Group Art Unit <b>2756</b>



The petition filed on \_\_\_\_\_ under 37 CFR 1.312(b) is granted. The paper has been forwarded to the examiner for consideration on the merits.

The amendment filed on 7/14/99 under 37 CFR 1.312 has been considered, and has been:

- entered.
- entered as directed to matters of form not affecting the scope of the invention (Order 3311).
- disapproved. See explanation below.
- entered in part. See explanation below.



**Mark H. Rinehart  
Primary Examiner**

**MARK RINEHART  
PRIMARY EXAMINER  
ART UNIT 2756**

PATENT RESEARCH INQUIRY FORM PRJF-1

DEPARTMENT CT TEAM 5  
 PATENT # 4881 WEEK DATE 8/23

**RESEARCH REQUEST**

patent has 3 inventors  
but in jacket only one inventor?  
per paper # 30, 31 and #32, 2 Inventors has been added on the OATH,  
but there is only 1 inventor on bot. please update. Thanks

Action Requested by: Hpa/Vanle Date: 7/12/00

**DESCRIPTION OF RESOLUTION**  
*Please complete Disposition section*

\_\_\_\_\_

\_\_\_\_\_

\_\_\_\_\_

\_\_\_\_\_

Action Requested by: \_\_\_\_\_ Date: \_\_\_\_\_

**DISPOSITION**

MAKE CORRECTION:                       In Production

USE AS IS     External Department: \_\_\_\_\_  
Please specify department and wand to group

---

COMMUNICATION:                       Distribute Department wide as example only

Manual Improvement/Suggestion Form Needed\*  
\*Response is for this patent only unless this box is checked

---

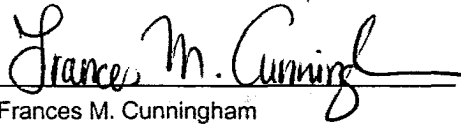
NON CONFORMING:                       Return on Query                       Return to FMF

*- Do not release non-conforming files -*



<b>REQUEST FOR WITHDRAWAL AS ATTORNEY OR AGENT</b>	Docket No. N0003/7000
Applicant: Glenn W. Hutton, et al. Patent No.: 6,108,704 Issued: August 22, 2000 For: POINT-TO-POINT INTERNET PROTOCOL	

CERTIFICATE OF MAILING UNDER 37 C.F.R. §1.8(a)  
The undersigned hereby certifies that this document is being placed in the United States mail with first-class postage attached, addressed to Assistant Commissioner for Patents, Washington, DC 20231 on January 11, 2002.

  
Frances M. Cunningham

Assistant Commissioner for Patents  
Washington, D.C. 20231

**Request**

The undersigned hereby requests to withdraw as attorney or agent for the above-identified patent for himself and the attorneys listed under customer number:



21127

PATENT TRADEMARK OFFICE

As grounds in support of this request, the undersigned attorney asserts that client/Assignee of record for the above-identified patent has been recently acquired by ADIR VOIP Technologies, Inc. of Newark, New Jersey. The new owners are transferring responsibility for the above-identified patent to other counsel.

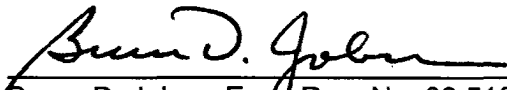
Please change the correspondence address and direct all future correspondence for the above-identified patent to:

Jeffrey S. Ginsberg, Esq.  
KENYON & KENYON  
One Broadway  
New York, NY 10004

A copy of this request is being sent to the client on an even date herewith by registered mail, return receipt requested, at client's last known address. All papers and property that relate to the above-identified patent unto which the client is entitled are being sent to the client's new counsel via courier an even date herewith. No fee has been paid by client in advance. Accordingly, there is no unearned fee to be refunded to client.

The Commissioner is hereby authorized to charge any other fees under 37 C.F.R. §1.16 and §1.17 that may be required, or credit any overpayment, to our Deposit Account No. 02-3038. Thereafter, any authorization which may have been given to charge Deposit Account 02-3038 is also hereby withdrawn.

Respectfully submitted,



Bruce D. Jobse, Esq. Reg. No. 33,518  
KUDIRKA & JOBSE, LLP  
Customer Number 021127  
Tel: (617) 367-4600 Fax (617) 367-4656

Date: January 11, 2002



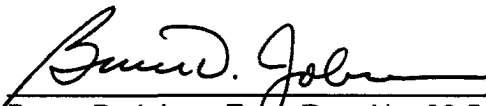
DSD

<b>TRANSMITTAL LETTER</b>	Docket No. N0003/7000
Applicant: Glenn W. Hutton, et al. Patent No: 6,108,704 Issued: August 22, 2000 For: POINT-TO-POINT INTERNET PROTOCOL	

Assistant Commissioner for Patents  
Washington, D.C. 20231

**Enclosures**

- |   |  |
|---|--|
| <input type="checkbox"/> Affidavit under 37 C.F.R. 1.131    | <input type="checkbox"/> Request for Certified Copies                                  |
| <input type="checkbox"/> Assignment Papers                  | <input type="checkbox"/> Request for Corrected Filing-Receipt                          |
| <input type="checkbox"/> Change of Correspondence Address   | <input type="checkbox"/> Copy of Original Filing Receipt                               |
| <input type="checkbox"/> Extension of Time Request          | <input type="checkbox"/> Request for Reconsideration                                   |
| <input type="checkbox"/> Declaration/Power of Attorney      | <input type="checkbox"/> Request for Refund  |
| <input type="checkbox"/> Fee Transmittal Form               | <input type="checkbox"/> Response to Missing Parts                                     |
| <input type="checkbox"/> Information Disclosure Statement   | <input checked="" type="checkbox"/> Return Receipt Postcard                            |
| <input type="checkbox"/> Invention Disclosure Document      | <input type="checkbox"/> Sheets Formal Drawing(s)                                      |
| <input type="checkbox"/> Notice of Appeal                   | <input type="checkbox"/> Small Entity Statement  |
| <input type="checkbox"/> Petition and Petition Routing Slip | <input type="checkbox"/> Status Letter   |
| <input type="checkbox"/> Power of Attorney Form             | <input type="checkbox"/> Terminal Disclaimer   |
| <input type="checkbox"/> PTO-1449 Form(s)                   | <input checked="" type="checkbox"/> Other: Request for Withdrawal as Attorney or Agent |

  
 Bruce D. Jobse, Esq. Reg. No. 33,518  
 KUDIRKA & JOBSE, LLP  
 Customer Number 021127  
 Tel: (617) 367-4600 Fax: (617) 367-4656

Date: Jan. 11, 2002


**UNITED STATES PATENT AND TRADEMARK OFFICE**

 COMMISSIONER FOR PATENTS  
 UNITED STATES PATENT AND TRADEMARK OFFICE  
 WASHINGTON, D.C. 20231  
 www.uspto.gov

APPLICATION NUMBER	FILING DATE	FIRST NAMED APPLICANT	ATTY. DOCKET NO./TITLE
08/533,115	09/25/1995	GLENN W. HUTTON	649-2

**CONFIRMATION NO. 8714**


\*OC000000007505762\*

 21127  
 KUDIRKA & JOBSE, LLP  
 ONE STATE STREET  
 SUITE 1510  
 BOSTON, MA 02109

Date Mailed: 02/21/2002

**NOTICE REGARDING POWER OF ATTORNEY**

This is in response to the Power of Attorney filed 02/01/2002.

- The withdrawal as attorney in this application has been accepted. Future correspondence will be mailed to the new address of record. 37 CFR 1.33.

---

 RODNEY L GLOVER  
 OPR (703) 308-5906

OFFICE COPY


**UNITED STATES PATENT AND TRADEMARK OFFICE**

 COMMISSIONER FOR PATENTS  
 UNITED STATES PATENT AND TRADEMARK OFFICE  
 WASHINGTON, D.C. 20231  
 www.uspto.gov

APPLICATION NUMBER	FILING DATE	FIRST NAMED APPLICANT	ATTY. DOCKET NO./TITLE
08/533,115	09/25/1995	GLENN W. HUTTON	649-2

**CONFIRMATION NO. 8714**


\*OC000000007505784\*

 JEFFREY S. GINSBERG, ESQ.  
 KENYON & KENYON  
 ONE BROADWAY  
 NEW YORK, NY 10004

Date Mailed: 02/21/2002

**NOTICE REGARDING POWER OF ATTORNEY**

This is in response to the Power of Attorney filed 02/01/2002.

The Power of Attorney in this application is accepted. Correspondence in this application will be mailed to the above address as provided by 37 CFR 1.33.

---

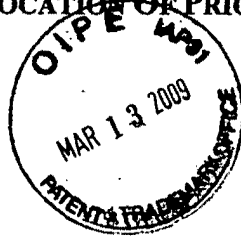
 RODNEY L GLOVER  
 OPR (703) 308-5906

OFFICE COPY

IN THE UNITED STATES PATENT AND TRADEMARK OFFICE

POWER OF ATTORNEY,  
CORRESPONDENCE ADDRESS  
AND REVOCATION OF PRIOR POWERS

Hon. Commissioner of Patents  
P.O. Box 1450  
Alexandria, VA 22313-1450



Sir:

**Revocation:** I hereby revoke all previous powers of attorney given in the application identified in the attached statement under 37 CFR 3.73(b).

**Power of Attorney:** I hereby appoint the practitioners associated with customer number **42624**, individually and collectively, as attorney(s) or agent(s) to represent the undersigned before the United States Patent and Trademark Office (USPTO) in connection with any and all patent applications assigned only to the undersigned according to the USPTO assignment records or assignment documents attached to this form in accordance with 37 CFR 3.73(b).

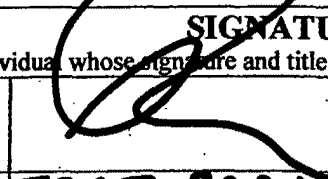
I authorize Davidson Berquist Jackson & Gowdey, LLP to delete names/numbers of persons no longer with the Firm and to act and rely on instructions from and communicate directly with the entity who first sent this case to them and by whom I hereby declare that I have consented after full disclosure to be represented unless/until I instruct Davidson Berquist Jackson & Gowdey, LLP in writing to the contrary.

**Correspondence Address:** Please recognize or change the correspondence address for the application identified in the attached statement under 37 CFR 3.73(b) to the address associated with Customer Number **42624**.

*Assignee Name and Address:*

Net2Phone, Inc.  
520 Broad Street, 8<sup>th</sup> Floor  
Newark, New Jersey 07102

A copy of this form, together with a statement under 37 CFR 3.73(b) (Form PTO/SB/96 or equivalent) is required to be filed in each application in which this form is used. The statement under 37 CFR 3.73(b) may be completed by one of the practitioners appointed in this form if the appointed practitioner is authorized to act on behalf of the assignee, and must identify the application in which this Power of Attorney is to be filed.

SIGNATURE of Assignee of Record			
The individual whose signature and title is supplied below is authorized to act on behalf of the assignee			
Signature		Date	3/12/09
Name	JAMES RAPPAH	Telephone	973 438 3153
Title	VP DIRECTOR		





08533115

ITW

### STATEMENT UNDER 37 CFR 3.73(B)

Applicant / Patent Owner: Net2Phone, Inc.

Docket No. 2655-0021

Patent No. 6,108,704

Filed / Issued Date: 08/22/2000

Entitled: POINT-TO-POINT INTERNET PROTOCOL

Assignee: Net2Phone, Inc.

A corporation

(Name of assignee)

(Type of Assignee: corporation, partnership, university, government agency, etc.)

States that it is:

- 1.  the assignee of the entire right, title, and interest; or
- 2.  an assignee of less than the entire right, title and interest.  
(The extent (by percentage) of its ownership interest is        %)

in the patent application / patent identified above by virtue of either:

- A.  An assignment from the inventor(s) of the patent application / patent identified above. The assignment was recorded in the United States Patent and Trademark Office at Reel        , Frame        , or for which a copy thereof is attached.

OR

- B.  A chain of title from the inventor(s), of the patent application / patent identified above, to the current assignee shown below:

1.	From: <u>HUTTON, Glen W.</u> To: <u>Internet Telephone Company</u> The document was recorded in the United States Patent and Trademark Office at Reel <u>007981</u> Frame <u>0020</u> , or for which a copy thereof is attached.
2.	From: <u>HUTTON, Glenn W.</u> To: <u>Internet Telephone Company</u> The document was recorded in the United States Patent and Trademark Office at Reel <u>008295</u> Frame <u>0167</u> , or for which a copy thereof is attached.
3.	From: <u>Internet Telephone Company</u> To: <u>Netspeak Corporation</u> The document was recorded in the United States Patent and Trademark Office at Reel <u>007981</u> Frame <u>0053</u> , or for which a copy thereof is attached.

- Additional documents in the chain of title are listed on a supplemental sheet.
- Copies of assignments or other documents in the chain of title are attached.

As required by 37 CFR 3.73(b)(1)(i), the documentary evidence of the chain of title from the original owner to the assignee was, or concurrently is being, submitted for recordation pursuant to 37 CFR 3.11.

[Note: A separate copy (i.e., a true copy of the original assignment document(s)) must be submitted to Assignment Division in accordance with 37 CFR Part 3, if the assignment is to be recorded in the records of the USPTO. See MPEP 302.08]

The undersigned (whose title is supplied below) is authorized to act on behalf of the assignee.

Michael R. Casey  
Signature

3/13/09  
Date

Michael R. Casey, Ph. D.  
Printed or Typed Name

703-894-6400  
Telephone Number

Attorney, Registration No. 40,294  
Title: \_\_\_\_\_



STATEMENT UNDER 37 CFR 3.73(B)  
Continued

4.	From: <u>STRICKLAND, Craig B.</u> To: <u>Netspeak Corporation</u> The document was recorded in the United States Patent and Trademark Office at Reel <u>009792</u> Frame <u>0568</u> , or for which a copy thereof is attached.
5.	From: <u>MATTAWAY, Shane D.</u> To: <u>Netspeak Corporation</u> The document was recorded in the United States Patent and Trademark Office at Reel <u>010012</u> Frame <u>0953</u> , or for which a copy thereof is attached.
6.	From: <u>Netspeak Corporation</u> To: <u>VOIP Technology Holdings, LLC</u> The document was recorded in the United States Patent and Trademark Office at Reel <u>016522</u> Frame <u>0205</u> , or for which a copy thereof is attached.
7.	From: <u>VOIP Technology Holdings, LLC</u> To: <u>Net2Phone, Inc.</u> The document was recorded in the United States Patent and Trademark Office at Reel <u>016945</u> Frame <u>0858</u> , or for which a copy thereof is attached.
8.	From: <u>Netspeak Corporation</u> To: <u>Net2Phone, Inc.</u> The document was recorded in the United States Patent and Trademark Office at Reel <u>016945</u> Frame <u>0890</u> , or for which a copy thereof is attached.
9.	From: <u>VOIP Technology Holdings, LLC</u> To: <u>Net2Phone, Inc.</u> The document was recorded in the United States Patent and Trademark Office at Reel <u>017105</u> Frame <u>0240</u> , or for which a copy thereof is attached.



UNITED STATES PATENT AND TRADEMARK OFFICE

UNITED STATES DEPARTMENT OF COMMERCE  
United States Patent and Trademark Office  
Address: COMMISSIONER FOR PATENTS  
P.O. Box 1450  
Alexandria, Virginia 22313-1450  
www.uspto.gov

APPLICATION NUMBER	FILING OR 371(C) DATE	FIRST NAMED APPLICANT	ATTY. DOCKET NO./TITLE
08/533,115	09/25/1995	GLENN W. HUTTON	2655-0021

**CONFIRMATION NO. 8714**

**POA ACCEPTANCE LETTER**

42624  
DAVIDSON BERQUIST JACKSON & GOWDEY LLP  
4300 WILSON BLVD., 7TH FLOOR  
ARLINGTON, VA 22203



Date Mailed: 03/25/2009

**NOTICE OF ACCEPTANCE OF POWER OF ATTORNEY**

This is in response to the Power of Attorney filed 03/13/2009.

The Power of Attorney in this application is accepted. Correspondence in this application will be mailed to the above address as provided by 37 CFR 1.33.

/sabuna/

Office of Data Management, Application Assistance Unit (571) 272-4000, or (571) 272-4200, or 1-888-786-0101

AO 120 (Rev. 08/10)

TO: <b>Mail Stop 8</b> <b>Director of the U.S. Patent and Trademark Office</b> <b>P.O. Box 1450</b> <b>Alexandria, VA 22313-1450</b>	<b>REPORT ON THE</b> <b>FILING OR DETERMINATION OF AN</b> <b>ACTION REGARDING A PATENT OR</b> <b>TRADEMARK</b>
---	---

In Compliance with 35 U.S.C. § 290 and/or 15 U.S.C. § 1116 you are hereby advised that a court action has been filed in the U.S. District Court for the Eastern District of Virginia on the following

Trademarks or  Patents. (  the patent action involves 35 U.S.C. § 292.);

DOCKET NO. <i>2:12cv9</i>	DATE FILED <i>1/4/12</i>	U.S. DISTRICT COURT for the Eastern District of Virginia
PLAINTIFF INNOVATIVE COMMUNICATIONS TECHS., INC.		DEFENDANT STALKER SOFTWARE, INC. d/b/a CommuniGate Systems, Inc.
PATENT OR TRADEMARK NO.	DATE OF PATENT OR TRADEMARK	HOLDER OF PATENT OR TRADEMARK
1 6,108,704	8/22/2000	INNOVATIVE COMMUNICATIONS TECHNOLOGIES, INC.
2 6,513,066	1/28/2003	INNOVATIVE COMMUNICATIONS TECHNOLOGIES, INC.
3 6,701,365	3/2/2004	INNOVATIVE COMMUNICATIONS TECHNOLOGIES, INC.
4		
5		

In the above—entitled case, the following patent(s)/ trademark(s) have been included:

DATE INCLUDED	INCLUDED BY <input type="checkbox"/> Amendment <input type="checkbox"/> Answer <input type="checkbox"/> Cross Bill <input type="checkbox"/> Other Pleading
PATENT OR TRADEMARK NO.	DATE OF PATENT OR TRADEMARK HOLDER OF PATENT OR TRADEMARK
1	
2	
3	
4	
5	

In the above—entitled case, the following decision has been rendered or judgement issued:

DECISION/JUDGEMENT
--------------------

CLERK <i>FERNANDO GALINDO</i>	(BY) DEPUTY CLERK <i>BRIAN NEWELL</i>	DATE 1/4/2012
----------------------------------	--	------------------

Copy 1—Upon initiation of action, mail this copy to Director Copy 3—Upon termination of action, mail this copy to Director  
 Copy 2—Upon filing document adding patent(s), mail this copy to Director Copy 4—Case file copy

AO 120 (Rev. 08/10)

TO: <b>Mail Stop 8</b> <b>Director of the U.S. Patent and Trademark Office</b> <b>P.O. Box 1450</b> <b>Alexandria, VA 22313-1450</b>	<b>REPORT ON THE</b> <b>FILING OR DETERMINATION OF AN</b> <b>ACTION REGARDING A PATENT OR</b> <b>TRADEMARK</b>
---	---

In Compliance with 35 U.S.C. § 290 and/or 15 U.S.C. § 1116 you are hereby advised that a court action has been filed in the U.S. District Court for the Eastern District of Virginia on the following  
 Trademarks or  Patents. (  the patent action involves 35 U.S.C. § 292.);

DOCKET NO. <i>2:12cv9</i>	DATE FILED <i>1/4/12</i>	U.S. DISTRICT COURT for the Eastern District of Virginia
PLAINTIFF <b>INNOVATIVE COMMUNICATIONS TECHS., INC.</b>		DEFENDANT <b>STALKER SOFTWARE, INC.d/b/a CommuniGate Systems, Inc.</b>
PATENT OR TRADEMARK NO.	DATE OF PATENT OR TRADEMARK	HOLDER OF PATENT OR TRADEMARK
1 6,108,704	8/22/2000	INNOVATIVE COMMUNICATIONS TECHNOLOGIES, INC.
2 6,513,066	1/28/2003	INNOVATIVE COMMUNICATIONS TECHNOLOGIES, INC.
3 6,701,365	3/2/2004	INNOVATIVE COMMUNICATIONS TECHNOLOGIES, INC.
4		
5		

In the above—entitled case, the following patent(s)/ trademark(s) have been included:

DATE INCLUDED	INCLUDED BY <input type="checkbox"/> Amendment <input type="checkbox"/> Answer <input type="checkbox"/> Cross Bill <input type="checkbox"/> Other Pleading		
PATENT OR TRADEMARK NO.	DATE OF PATENT OR TRADEMARK	HOLDER OF PATENT OR TRADEMARK	
1			
2			
3			
4			
5			

In the above—entitled case, the following decision has been rendered or judgement issued:

DECISION/JUDGEMENT
--------------------

CLERK <i>FERNANDO GALINDO</i>	(BY) DEPUTY CLERK <i>BRIAN NEWELL</i>	DATE 1/4/2012
----------------------------------	--	------------------

Copy 1—Upon initiation of action, mail this copy to Director    Copy 3—Upon termination of action, mail this copy to Director  
 Copy 2—Upon filing document adding patent(s), mail this copy to Director    Copy 4—Case file copy

AO 120 (Rev. 08/10)

TO: <b>Mail Stop 8</b> <b>Director of the U.S. Patent and Trademark Office</b> P.O. Box 1450 Alexandria, VA 22313-1450	<b>REPORT ON THE                  FILING OR DETERMINATION OF AN                  ACTION REGARDING A PATENT OR                  TRADEMARK</b>
---	--

In Compliance with 35 U.S.C. § 290 and/or 15 U.S.C. § 1116 you are hereby advised that a court action has been filed in the U.S. District Court for the Eastern District of Virginia on the following

Trademarks or  Patents. (  the patent action involves 35 U.S.C. § 292.);

DOCKET NO. <i>2-12 cv 9</i>	DATE FILED <i>1/4/12</i>	U.S. DISTRICT COURT for the Eastern District of Virginia
PLAINTIFF INNOVATIVE COMMUNICATIONS TECHS., INC.		DEFENDANT STALKER SOFTWARE, INC. d/b/a CommuniGate Systems, Inc.
PATENT OR TRADEMARK NO.	DATE OF PATENT OR TRADEMARK	HOLDER OF PATENT OR TRADEMARK
1 6,108,704	8/22/2000	INNOVATIVE COMMUNICATIONS TECHNOLOGIES, INC.
2 6,513,066	1/28/2003	INNOVATIVE COMMUNICATIONS TECHNOLOGIES, INC.
3 6,701,365	3/2/2004	INNOVATIVE COMMUNICATIONS TECHNOLOGIES, INC.
4		
5		

In the above—entitled case, the following patent(s)/ trademark(s) have been included:

DATE INCLUDED	INCLUDED BY <input type="checkbox"/> Amendment <input type="checkbox"/> Answer <input type="checkbox"/> Cross Bill <input type="checkbox"/> Other Pleading
PATENT OR TRADEMARK NO.	DATE OF PATENT OR TRADEMARK HOLDER OF PATENT OR TRADEMARK
1	
2	
3	
4	
5	

In the above—entitled case, the following decision has been rendered or judgement issued:

DECISION/JUDGEMENT
--------------------

CLERK <i>FERNANDO GALINDO</i>	(BY) DEPUTY CLERK <i>Brian Newell</i>	DATE 1/4/2012
----------------------------------	--	------------------

Copy 1—Upon initiation of action, mail this copy to Director    Copy 3—Upon termination of action, mail this copy to Director  
 Copy 2—Upon filing document adding patent(s), mail this copy to Director    Copy 4—Case file copy

TO: **Mail Stop 8  
Director of the U.S. Patent and Trademark Office  
P.O. Box 1450  
Alexandria, VA 22313-1450**

**REPORT ON THE  
FILING OR DETERMINATION OF AN  
ACTION REGARDING A PATENT OR  
TRADEMARK**

In Compliance with 35 U.S.C. § 290 and/or 15 U.S.C. § 1116 you are hereby advised that a court action has been filed in the U.S. District Court \_\_\_\_\_ for the Eastern District of Virginia \_\_\_\_\_ on the following

Trademarks or  Patents. (  the patent action involves 35 U.S.C. § 292.);

DOCKET NO. <i>2:12cv9</i>	DATE FILED <i>1/4/12</i>	U.S. DISTRICT COURT for the Eastern District of Virginia
PLAINTIFF INNOVATIVE COMMUNICATIONS TECHS., INC.		DEFENDANT STALKER SOFTWARE, INC.d/b/a CommuniGate Systems, Inc.
PATENT OR TRADEMARK NO.	DATE OF PATENT OR TRADEMARK	HOLDER OF PATENT OR TRADEMARK
1 6,108,704	8/22/2000	INNOVATIVE COMMUNICATIONS TECHNOLOGIES, INC.
2 6,513,066	1/28/2003	INNOVATIVE COMMUNICATIONS TECHNOLOGIES, INC.
3 6,701,365	3/2/2004	INNOVATIVE COMMUNICATIONS TECHNOLOGIES, INC.
4		
5		

In the above—entitled case, the following patent(s)/ trademark(s) have been included:

DATE INCLUDED	INCLUDED BY	
	<input type="checkbox"/> Amendment <input type="checkbox"/> Answer <input type="checkbox"/> Cross Bill <input type="checkbox"/> Other Pleading	
PATENT OR TRADEMARK NO.	DATE OF PATENT OR TRADEMARK	HOLDER OF PATENT OR TRADEMARK
1		
2		
3		
4		
5		

In the above—entitled case, the following decision has been rendered or judgement issued:

DECISION/JUDGEMENT  
*12/21/12: Stipulation of Dismissal filed - Case Closed*

CLERK <i>FERNANDO GALINDO</i>	(BY) DEPUTY CLERK <i>ELISE CAWANA</i>	DATE <i>12/27/12</i>
----------------------------------	--	-------------------------

Copy 1—Upon initiation of action, mail this copy to Director Copy 3—Upon termination of action, mail this copy to Director  
Copy 2—Upon filing document adding patent(s), mail this copy to Director Copy 4—Case file copy

AO 120 (Rev. 08/10)

<b>TO:</b> <b>Mail Stop 8</b> <b>Director of the U.S. Patent and Trademark Office</b> <b>P.O. Box 1450</b> <b>Alexandria, VA 22313-1450</b>	<b>REPORT ON THE</b> <b>FILING OR DETERMINATION OF AN</b> <b>ACTION REGARDING A PATENT OR</b> <b>TRADEMARK</b>
---	---

In Compliance with 35 U.S.C. § 290 and/or 15 U.S.C. § 1116 you are hereby advised that a court action has been filed in the U.S. District Court Eastern District of Virginia on the following

Trademarks or  Patents . (  the patent action involves 35 U.S.C. § 292.):

DOCKET NO. 3:13CV503	DATE FILED 8/2/2013	U.S. DISTRICT COURT Richmond
PLAINTIFF Straight Path IP Group, Inc.		DEFENDANT Toshiba Corporation Toshiba America, Inc. Toshiba America Information Systems, Inc.
PATENT OR TRADEMARK NO.	DATE OF PATENT OR TRADEMARK	HOLDER OF PATENT OR TRADEMARK
1	6,009,469	
2	6,108,704	
3	6,131,121	
4		
5		

In the above—entitled case, the following patent(s)/ trademark(s) have been included:

DATE INCLUDED	INCLUDED BY <input type="checkbox"/> Amendment <input type="checkbox"/> Answer <input type="checkbox"/> Cross Bill <input type="checkbox"/> Other Pleading	
PATENT OR TRADEMARK NO.	DATE OF PATENT OR TRADEMARK	HOLDER OF PATENT OR TRADEMARK
1		
2		
3		
4		
5		

In the above—entitled case, the following decision has been rendered or judgement issued:

DECISION/JUDGEMENT
--------------------

CLERK Fernando Galindo	(BY) DEPUTY CLERK Robert L. Walker	DATE 8/8/2013
---------------------------	---------------------------------------	------------------

Copy 1—Upon initiation of action, mail this copy to Director Copy 3—Upon termination of action, mail this copy to Director  
 Copy 2—Upon filing document adding patent(s), mail this copy to Director Copy 4—Case file copy



AO 120 (Rev. 08/10)

TO: <b>Mail Stop 8</b> <b>Director of the U.S. Patent and Trademark Office</b> <b>P.O. Box 1450</b> <b>Alexandria, VA 22313-1450</b>	<b>REPORT ON THE</b> <b>FILING OR DETERMINATION OF AN</b> <b>ACTION REGARDING A PATENT OR</b> <b>TRADEMARK</b>
---	---

In Compliance with 35 U.S.C. § 290 and/or 15 U.S.C. § 1116 you are hereby advised that a court action has been filed in the U.S. District Court Eastern District of Virginia on the following

Trademarks or  Patents. (  the patent action involves 35 U.S.C. § 292.):

DOCKET NO. 1:13cv934	DATE FILED 8/1/2013	U.S. DISTRICT COURT Eastern District of Virginia
PLAINTIFF Straight Path IP Group, Inc.		DEFENDANT Vizio, Inc., et al.
PATENT OR TRADEMARK NO.	DATE OF PATENT OR TRADEMARK	HOLDER OF PATENT OR TRADEMARK
1 6,009,469	12/28/1999	NetSpeak Corporation
2 6,108,704	8/22/0200	NetSpeak Corporation
3 6,131,121	10/10/2000	NetSpeak Corporation
4		
5		

In the above—entitled case, the following patent(s)/ trademark(s) have been included:

DATE INCLUDED	INCLUDED BY <input type="checkbox"/> Amendment <input type="checkbox"/> Answer <input type="checkbox"/> Cross Bill <input type="checkbox"/> Other Pleading	
PATENT OR TRADEMARK NO.	DATE OF PATENT OR TRADEMARK	HOLDER OF PATENT OR TRADEMARK
1		
2		
3		
4		
5		

In the above—entitled case, the following decision has been rendered or judgement issued:

DECISION/JUDGEMENT
--------------------

CLERK	(BY) DEPUTY CLERK	DATE
-------	-------------------	------

Copy 1—Upon initiation of action, mail this copy to Director    Copy 3—Upon termination of action, mail this copy to Director  
 Copy 2—Upon filing document adding patent(s), mail this copy to Director    Copy 4—Case file copy

AO 120 (Rev. 08/10)

TO: <b>Mail Stop 8 Director of the U.S. Patent and Trademark Office P.O. Box 1450 Alexandria, VA 22313-1450</b>	<b>REPORT ON THE FILING OR DETERMINATION OF AN ACTION REGARDING A PATENT OR TRADEMARK</b>
---	---

In Compliance with 35 U.S.C. § 290 and/or 15 U.S.C. § 1116 you are hereby advised that a court action has been filed in the U.S. District Court for the Eastern District of Virginia - Norfolk Division on the following

Trademarks or  Patents. (  the patent action involves 35 U.S.C. § 292.):

DOCKET NO. 2:13cv427	DATE FILED 8/1/2013	U.S. DISTRICT COURT for the Eastern District of Virginia - Norfolk Division
PLAINTIFF STRAIGHT PATH IP GROUP, INC.		DEFENDANT SONY CORPORATION, et al
PATENT OR TRADEMARK NO.	DATE OF PATENT OR TRADEMARK	HOLDER OF PATENT OR TRADEMARK
1 6,009,469	12/28/1999	Straight Path IP Group, Inc.
2 6,108,704	8/22/2000	Straight Path IP Group, Inc.
3 6,131,121	10/10/2000	Straight Path IP Group, Inc.
4		
5		

In the above—entitled case, the following patent(s)/ trademark(s) have been included:

DATE INCLUDED	INCLUDED BY <input type="checkbox"/> Amendment <input type="checkbox"/> Answer <input type="checkbox"/> Cross Bill <input type="checkbox"/> Other Pleading		
PATENT OR TRADEMARK NO.	DATE OF PATENT OR TRADEMARK	HOLDER OF PATENT OR TRADEMARK	
1			
2			
3			
4			
5			

In the above—entitled case, the following decision has been rendered or judgment issued:

DECISION/JUDGEMENT
--------------------

CLERK Fernando Galindo	(BY) DEPUTY CLERK Brad Newell	DATE 8/2/2013
---------------------------	----------------------------------	------------------

Copy 1—Upon initiation of action, mail this copy to Director    Copy 3—Upon termination of action, mail this copy to Director  
Copy 2—Upon filing document adding patent(s), mail this copy to Director    Copy 4—Case file copy

AO 120 (Rev. 08/10)

TO: <b>Mail Stop 8 Director of the U.S. Patent and Trademark Office P.O. Box 1450 Alexandria, VA 22313-1450</b>	<b>REPORT ON THE FILING OR DETERMINATION OF AN ACTION REGARDING A PATENT OR TRADEMARK</b>
---	---

In Compliance with 35 U.S.C. § 290 and/or 15 U.S.C. § 1116 you are hereby advised that a court action has been filed in the U.S. District Court Eastern District of Virginia on the following

Trademarks or  Patents. (  the patent action involves 35 U.S.C. § 292.):

DOCKET NO. 1:13cv936	DATE FILED 8/1/2013	U.S. DISTRICT COURT Eastern District of Virginia
PLAINTIFF Straight Path IP Group, Inc.		DEFENDANT Sharp Corp., et al.
PATENT OR TRADEMARK NO.	DATE OF PATENT OR TRADEMARK	HOLDER OF PATENT OR TRADEMARK
1 6,009,469	12/28/1999	NetSpeak Corporation
2 6,108,704	8/22/2000	NetSpeak Corporation
3 6,131,121	10/10/2000	NetSpeak Corporation
4		
5		

In the above—entitled case, the following patent(s)/ trademark(s) have been included:

DATE INCLUDED	INCLUDED BY <input type="checkbox"/> Amendment <input type="checkbox"/> Answer <input type="checkbox"/> Cross Bill <input type="checkbox"/> Other Pleading	
PATENT OR TRADEMARK NO.	DATE OF PATENT OR TRADEMARK	HOLDER OF PATENT OR TRADEMARK
1		
2		
3		
4		
5		

In the above—entitled case, the following decision has been rendered or judgement issued:

DECISION/JUDGEMENT
--------------------

CLERK	(BY) DEPUTY CLERK	DATE
-------	-------------------	------

Copy 1—Upon initiation of action, mail this copy to Director    Copy 3—Upon termination of action, mail this copy to Director  
Copy 2—Upon filing document adding patent(s), mail this copy to Director    Copy 4—Case file copy

AO 120 (Rev. 08/10)

TO: <b>Mail Stop 8</b> <b>Director of the U.S. Patent and Trademark Office</b> <b>P.O. Box 1450</b> <b>Alexandria, VA 22313-1450</b>	<b>REPORT ON THE</b> <b>FILING OR DETERMINATION OF AN</b> <b>ACTION REGARDING A PATENT OR</b> <b>TRADEMARK</b>
---	---

In Compliance with 35 U.S.C. § 290 and/or 15 U.S.C. § 1116 you are hereby advised that a court action has been filed in the U.S. District Court \_\_\_\_\_ for the Eastern District of Virginia - Alexandria \_\_\_\_\_ on the following  
 Trademarks or  Patents . (  the patent action involves 35 U.S.C. § 292.):

DOCKET NO. 1:13cv935-GBL/TCB	DATE FILED 8/1/2013	U.S. DISTRICT COURT Eastern District of Virginia - Alexandria Division
PLAINTIFF Straight Path Group, Inc.		DEFENDANT Panasonic Corporation of North America, et al.
PATENT OR TRADEMARK NO.	DATE OF PATENT OR TRADEMARK	HOLDER OF PATENT OR TRADEMARK
1 6,009,469	12/28/1999	NetSpeak Corporation
2 6,108,704	8/22/2000	NetSpeak Corporation
3 6,131,121	10/10/2000	NetSpeak Corporation
4		
5		

In the above—entitled case, the following patent(s)/ trademark(s) have been included:

DATE INCLUDED	INCLUDED BY <input type="checkbox"/> Amendment <input type="checkbox"/> Answer <input type="checkbox"/> Cross Bill <input type="checkbox"/> Other Pleading		
PATENT OR TRADEMARK NO.	DATE OF PATENT OR TRADEMARK	HOLDER OF PATENT OR TRADEMARK	
1			
2			
3			
4			
5			

In the above—entitled case, the following decision has been rendered or judgement issued:

DECISION/JUDGEMENT
--------------------

CLERK FERNANDO GALINDO	(BY) DEPUTY CLERK	DATE
---------------------------	-------------------	------

Copy 1—Upon initiation of action, mail this copy to Director Copy 3—Upon termination of action, mail this copy to Director  
 Copy 2—Upon filing document adding patent(s), mail this copy to Director Copy 4—Case file copy

AO 120 (Rev. 08/10)

<b>TO:</b> <b>Mail Stop 8</b> <b>Director of the U.S. Patent and Trademark Office</b> <b>P.O. Box 1450</b> <b>Alexandria, VA 22313-1450</b>	<b>REPORT ON THE</b> <b>FILING OR DETERMINATION OF AN</b> <b>ACTION REGARDING A PATENT OR</b> <b>TRADEMARK</b>
--	---

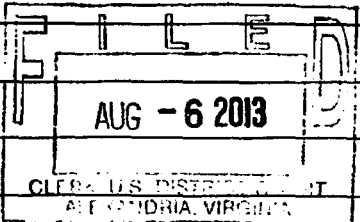
In Compliance with 35 U.S.C. § 290 and/or 15 U.S.C. § 1116 you are hereby advised that a court action has been filed in the U.S. District Court Eastern District of Virginia on the following

Trademarks or  Patents. (  the patent action involves 35 U.S.C. § 292.);

DOCKET NO. 1:13cv933	DATE FILED 8/1/2013	U.S. DISTRICT COURT Eastern District of Virginia
PLAINTIFF Straight Path IP Group, Inc.		DEFENDANT LG Electronics, Inc. LG Electronics U.S.A., Inc. LG Electronics MobileComm U.S.A., Inc.
PATENT OR TRADEMARK NO.	DATE OF PATENT OR TRADEMARK	HOLDER OF PATENT OR TRADEMARK
1 6,009,469	12/28/1999	Netspeak Corporation
2 6,108,704	8/22/2000	NetSpeak Corporation
3 6,131,121	10/10/2000	NetSpeak Corporation
4		
5		

In the above—entitled case, the following patent(s)/ trademark(s) have been included:

DATE INCLUDED	INCLUDED BY <input type="checkbox"/> Amendment <input type="checkbox"/> Answer <input type="checkbox"/> Cross Bill <input type="checkbox"/> Other Pleading	
PATENT OR TRADEMARK NO.	DATE OF PATENT OR TRADEMARK	HOLDER OF PATENT OR TRADEMARK
1		
2		
3		
4		
5		



In the above—entitled case, the following decision has been rendered or judgement issued:

DECISION/JUDGEMENT
--------------------

CLERK Fernando Galindo	(BY) DEPUTY CLERK	DATE 8/6/2013
---------------------------	-------------------	------------------

Copy 1—Upon initiation of action, mail this copy to Director    Copy 3—Upon termination of action, mail this copy to Director  
 Copy 2—Upon filing document adding patent(s), mail this copy to Director    Copy 4—Case file copy