



US005474327A

United States Patent [19]

[11] **Patent Number:** 5,474,327

Schousek

[45] **Date of Patent:** Dec. 12, 1995

[54] **VEHICLE OCCUPANT RESTRAINT WITH SEAT PRESSURE SENSOR**

Attorney, Agent, or Firm—Mark A. Navarre

[75] **Inventor:** Theresa J. Schousek, Kokomo, Ind.

[57] **ABSTRACT**

[73] **Assignee:** Delco Electronics Corporation, Kokomo, Ind.

An air bag restraint system is equipped with seat occupant sensing apparatus for a passenger seat which detects both infant seats and adults and distinguishes between rear and forward facing infant seats. Air bag deployment is inhibited when an occupied rear facing infant seat is present. The sensing apparatus comprises eight variable resistance pressure sensor in the seat cushion. The response of each sensor to occupant pressure is monitored by a microprocessor which calculated total weight and weight distribution. The weight is used to discriminate between an occupied infant seat, an adult and no occupant. The weight distribution is used to distinguish between forward and rear facing infant seats. Another embodiment uses the occupant sensing along with seat belt fastening detection to indicate when a seat is occupied and the belt is not fastened.

[21] **Appl. No.:** 325,718

[22] **Filed:** Jan. 10, 1995

[51] **Int. Cl.⁶** B60R 21/32

[52] **U.S. Cl.** 280/735; 180/268; 280/730.1

[58] **Field of Search** 280/730.1, 732, 280/735; 180/268

[56] **References Cited**

U.S. PATENT DOCUMENTS

5,074,583	12/1991	Fujita et al.	280/735
5,161,820	11/1992	Vollmer	280/730.1
5,172,790	12/1992	Ishikawa et al.	180/268
5,232,243	8/1993	Blackburn et al.	280/732

OTHER PUBLICATIONS

Alps Product Brochure (publication date unknown).
Interlink Product Brochure (publication date unknown).

Primary Examiner—Kenneth R. Rice

11 Claims, 4 Drawing Sheets

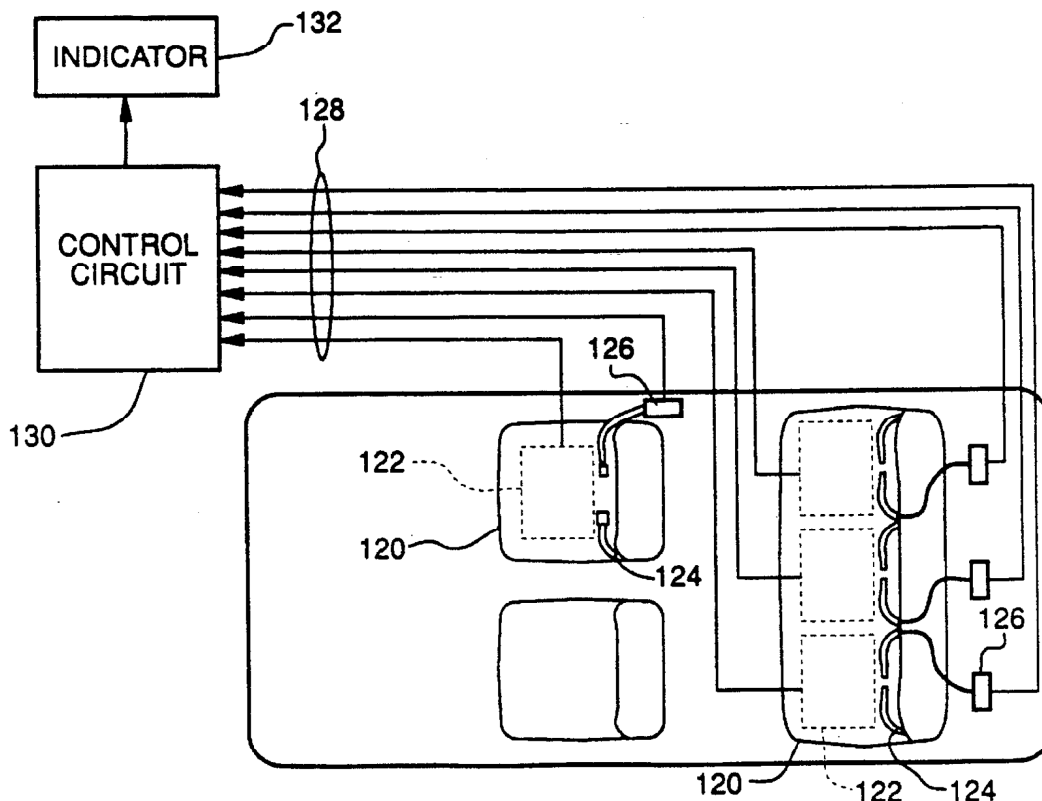

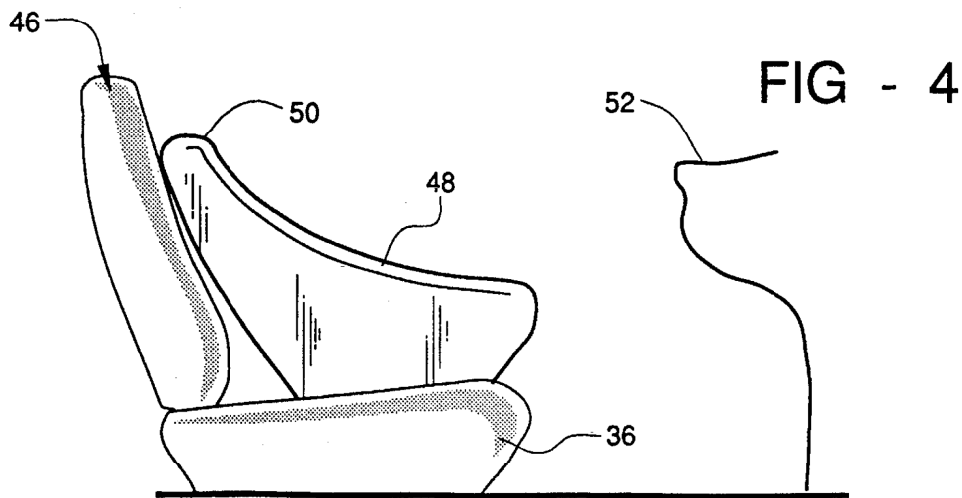
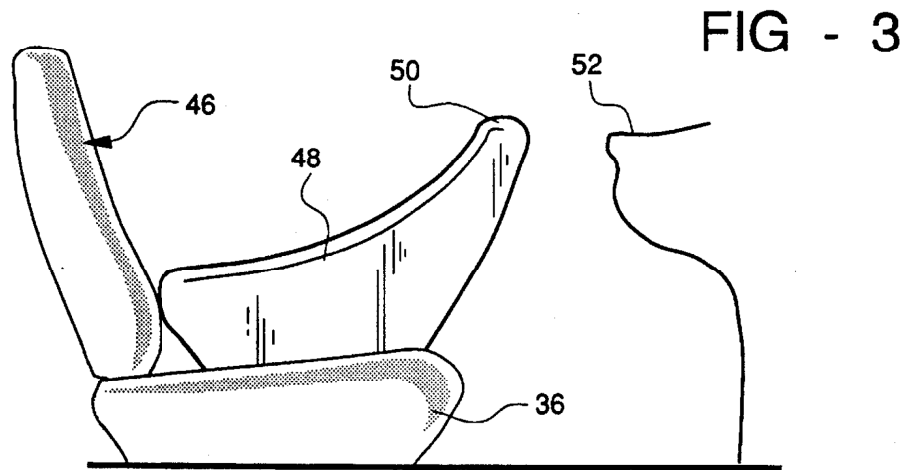
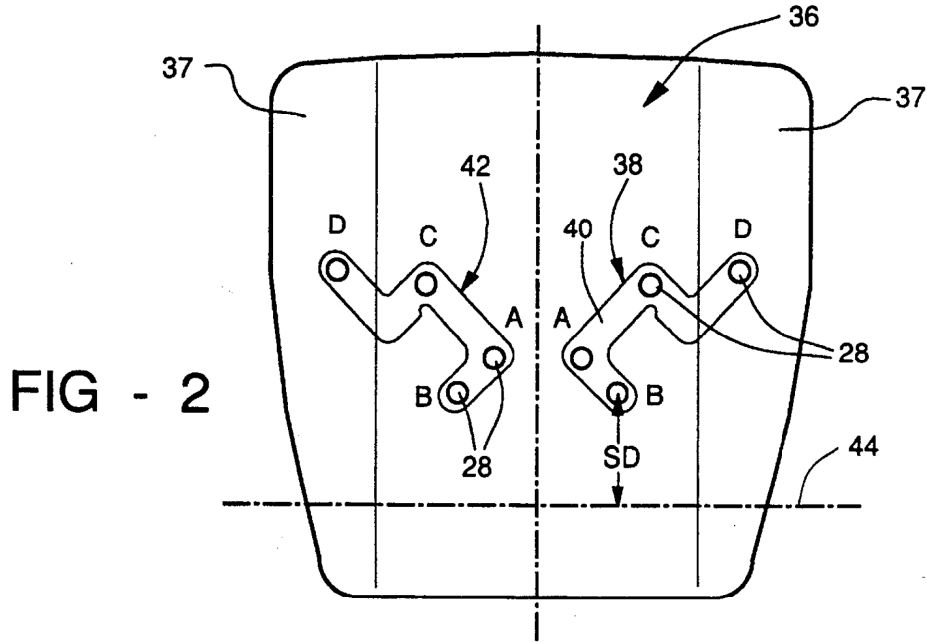

FIG - 5A

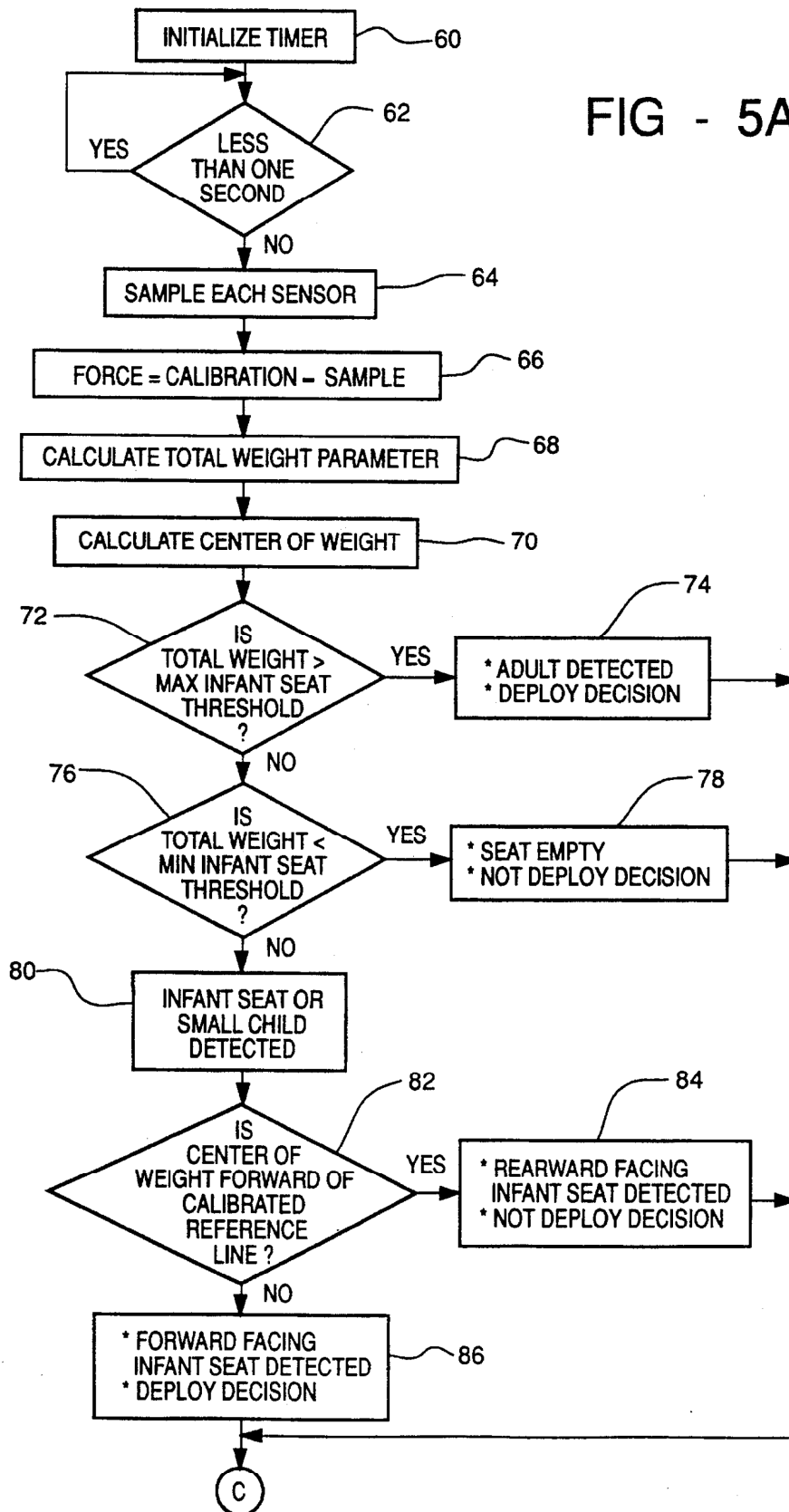
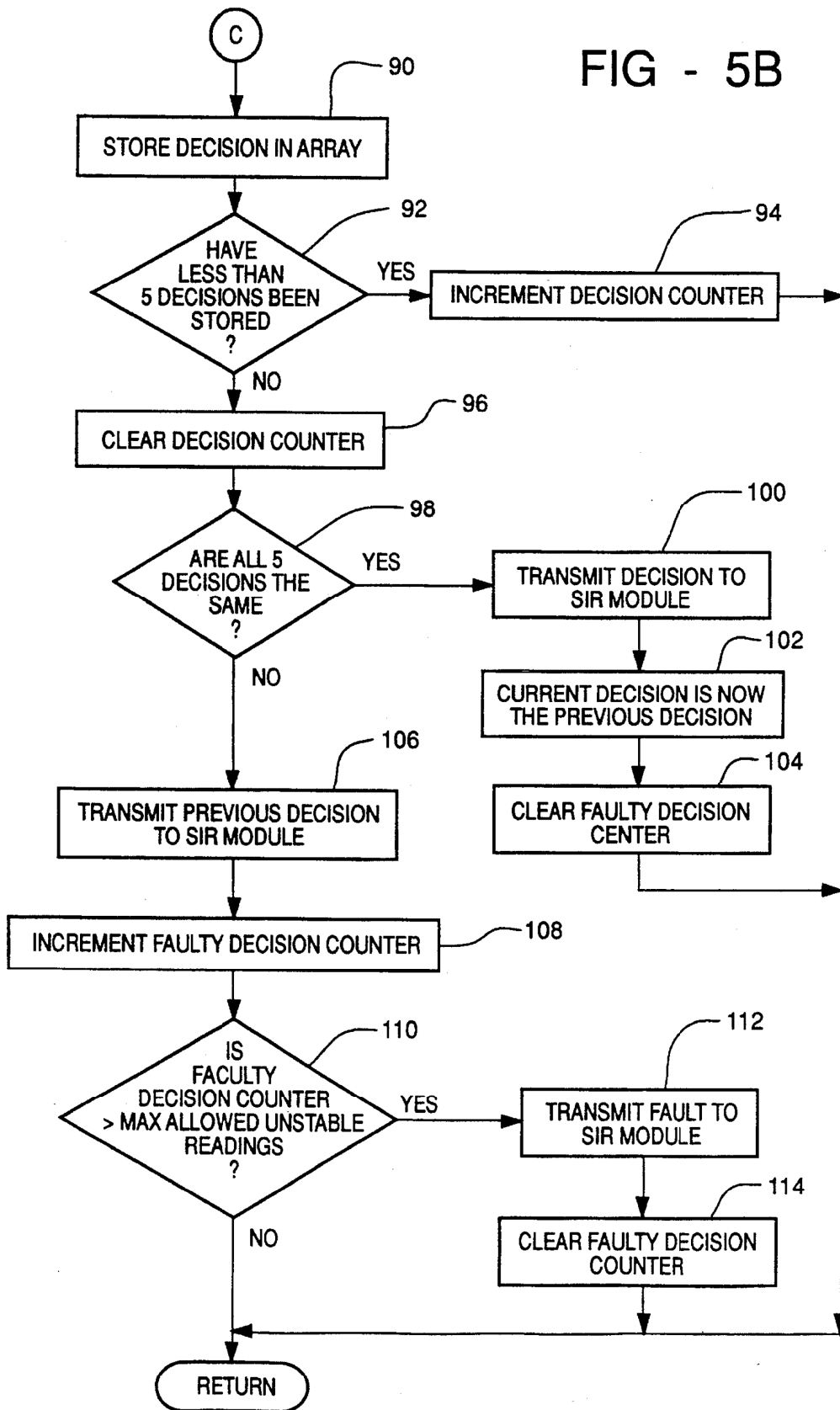

FIG - 5B



Explore Litigation Insights

Docket Alarm provides insights to develop a more informed litigation strategy and the peace of mind of knowing you're on top of things.

Real-Time Litigation Alerts



Keep your litigation team up-to-date with **real-time alerts** and advanced team management tools built for the enterprise, all while greatly reducing PACER spend.

Our comprehensive service means we can handle Federal, State, and Administrative courts across the country.

Advanced Docket Research



With over 230 million records, Docket Alarm's cloud-native docket research platform finds what other services can't. Coverage includes Federal, State, plus PTAB, TTAB, ITC and NLRB decisions, all in one place.

Identify arguments that have been successful in the past with full text, pinpoint searching. Link to case law cited within any court document via Fastcase.

Analytics At Your Fingertips



Learn what happened the last time a particular judge, opposing counsel or company faced cases similar to yours.

Advanced out-of-the-box PTAB and TTAB analytics are always at your fingertips.

API

Docket Alarm offers a powerful API (application programming interface) to developers that want to integrate case filings into their apps.

LAW FIRMS

Build custom dashboards for your attorneys and clients with live data direct from the court.

Automate many repetitive legal tasks like conflict checks, document management, and marketing.

FINANCIAL INSTITUTIONS

Litigation and bankruptcy checks for companies and debtors.

E-DISCOVERY AND LEGAL VENDORS

Sync your system to PACER to automate legal marketing.