

¹⁹ THE PATENT OFFICE OF JAPAN (JP)
¹² OFFICIAL GAZETTE FOR EXAMINED PATENTS (Y2)

¹¹ Disclosure Number

57-60171

⁵¹ Int. Cl³

Identification
Symbols

Intra-Agency File
Nos.

F 21 Q 1/00

6908-3K

^{24,44} Date of Publication

December 22, 1982
(total 5 pages)

⁵⁴ Title Vehicle light fixture

²¹ Application Number

53-78021

²² Filing Date

June 9, 1978

⁶⁵ Publication

54-180552

⁴³ December 20, 1979

⁷² Inventors

TSUBOI Toshitsuke
500 Kitawaki, Kiyomizu-shi
Koito Works Ltd., Shizuoka Plant

⁷¹ Applicant

Koito Works Ltd.
8-3 4-chome, Takanawa, Minato-ku, Tokyo-to

⁷⁴ Agent Attorney YAMAGAWA Masaki
and one other

⁵⁶ Cited Literature

Patent Publication No. 57-13081 (JP, B2)

⁵⁷ Scope of Utility Model Claims

A vehicle light fixture with a light guide space having a roughly L shaped cross section that comprises a space located at the front of the light source formed by a fixture body and a front lens and a space located on the side, said light guide space having a light guide plate deployed from the forward space to the lateral space, and light from the light source is accepted from the lighting member formed at the edge of the light source side of the light guide plate, wherein the lighting member of the aforementioned light guide plate is formed in serrated shape by a plurality of prisms comprising a flat plane extending toward the incident light beam and a refraction plane that refracts the incident light beam.

Detailed Description of the Device

This device is a vehicle light fixture that has a light guide space with a roughly L shaped cross section mounted laterally, especially a vehicle light fixture in which lateral illumination is improved using a light guide plate that is deployed within a light guide space.

For example, in vehicle light fixtures that incorporate a tail light, a stop light, and a directional indicator like combination lights, the fixture body and the front lens should be formed in a roughly L shape that matches the vehicular body shape so that the directional indicator deployed on the outside can be confirmed from the vehicle side for traffic safety considerations, and it should be structured so that light from the light source is irradiated to the side of the vehicle via a light guide space formed in these spaces.

Incidentally, in a vehicle light fixture with such a structure, irradiation of light from the light source to the side is difficult if a simple light guide space is formed. Furthermore, such effects are difficult to realize if a prism or reflecting mirror is installed in the section within the light guide space irradiated by light from the light source. Finally, the brightness of the light fixture on the side is dim compared to the brightness at the front, and the visibility is poor.

Consequently, in a conventional vehicle light fixture of this type, as shown in Figure 1 and Figure 2, a light guide plate is deployed within the light guide space. Specifically, a light guide space 3 with a roughly L shaped cross section is formed between the fixture body 1 and the front lens 2 in the vehicle light fixture shown in Figure 1. This light guide space 3 comprises anterior space 3a that is located in front of the bulb 4 and lateral space 3b that is located to the side. A light guide plate 5 formed from transparent synthetic resin is deployed in the light guide space 3 from the anterior space 3a to the lateral space 3b. Light from the bulb 4 is conveyed by the light guide plate 5 to the ends of lateral space 3b so as to form uniform illumination over the entire surface of the front lens 2. For this reason, the light guide plate 5 is formed with a curvature roughly equal to that of the side of the front lens 2, specifically, equal to that of the line in a section corresponding to light guide space 3 from one edge of anterior space 3a to lateral space 3b. Lighting member 6 comprising curved surface 6a that is curved inward so that light is accepted from the bulb 4 is formed at the edge of the side of anterior space 3a of the light guide plate 5. In addition, reflection member 7 comprising serrated shape steps formed so as to reflect incident light from the lighting member 6 along the curve of the front lens 2 is installed on the inside of the light guide plate 5, specifically, on the side of the fixture body 1.

In a vehicle light fixture with such a structure, the lighting member 6 is formed with a curved surface 6a so that its area would increase, and so as to accept light from the bulb 4 and to conduct it to the other edge of the light guide plate 5, as shown in Figure 1. However, light from the bulb 4 is refracted by the lighting member 6 so as to strike the outside of the light guide plate 5, specifically, the outer surface 5a on the side of the front lens 2 as denoted by the broken line in Figure 1. Since the incident angle is smaller than the critical angle, only part of the light is reflected to the side of the reflection member 7. Another part 8a of the light passes through the light guide plate 5 and is conducted out from the front lens 2. On the other hand, the light 8b that had advanced within the light guide plate 5 is conducted to the edge of the light guide plate 5 while reflected repeatedly between the reflection member 7 and the outer surface 5a, as shown in the diagram. Accordingly, each time light 8 is reflected at such a light guide plate 5, part of it is conducted outside. Because of the high frequency of said reflection, light 8c that is irradiated from the tip of the light guide plate 5 does not constitute bright illumination. As a result, uniform illumination

cannot be realized over the entire surface of the front lens 2 in a vehicle light fixture with such a structure, and the visibility is not good.

Consequently, the lighting member 6 of the light guide plate 5 is formed by tilted surface 6b so as to be distant from the bulb 4, as shown in Figure 2. It is structured so that incident light beam 9 from the bulb 4 that had been refracted by this tilted surface 6b is irradiated at a greater incident angle than the critical angle at the outer surface 5a of the light guide plate 5. By so doing, it can be conducted to the tip of the light guide plate 5 at a low reflection frequency with a reduction in the optical power loss due to reflection. However, since the incident optical power at the tilted surface 6b is too slight in such a light guide plate 5, the optical power of light 9a irradiated from the tip of the light guide plate 5 is slight and the visibility is poor, similarly to the aforementioned condition, as shown in Figure 2.

In addition, a reflection mirror 10 had been installed outside of the light guide space 3 to reflect light from the bulb 4, as shown in Figure 3. This increases the incident optical power to the lighting member 6 of the light guide plate 5, and while adjusting the incident angle, it conducts the incident light beam 9 at a low reflection frequency to the tip of the light guide plate 5 with a minimum optical power loss. In such a structure, the deployment of the reflection mirror 10 at the junction section of the fixture body 1 and the front lens 2 that face the lighting member 6 of the light guide plate 5 would be best in terms of visibility of the light fixture. Furthermore, the positioning of the lighting member 6 of the reflection mirror 10 is simple, as shown in the diagram, when the reflection mirror 10 is integrally formed with the shade or the rim 11 that is installed in this section, and assembly of this unit is simple as well.

However, such a structure requires the reflection mirror 10, the rim 11 for formation of this reflection mirror 10 as well as chrome plating. Such operations are a bother and the visibility at the surface of the front lens 2 corresponding to the reflection mirror 10 deteriorates as well.

In light of these circumstances, this device has a lighting member formed at the edge of the light source side of a light guide plate in serrated shape by a plurality of prisms comprising a flat plane extending in the direction of the incident light beam and a refraction plane that refracts the incident light beam. The lighting member area is formed to be great and so that incident light beams from the lighting member would be efficiently conducted to the tip of the light guide plate. By so doing, a vehicle light fixture with uniform, bright illumination over the entire surface of the front lens via a simple structure and with improved visibility can be provided. This device is explained in further detail below using embodiments presented in the following diagrams.

Figure 4 presents one embodiment of the vehicle light fixture pursuant to the present device. Those structures that are identical with those in Figures 1 to 3 are designated by the same notation. A light guide plate 5 comprising transparent synthetic resin is deployed within the light guide space 3 in this vehicle light fixture shown in the diagram. This light guide plate 5 is welded to protrusions 2a, 2b erected on the inside of the front lens 2.

In this device, the lighting member 6 that is installed on the bulb 4 side of the light guide plate 5, specifically at the edge of the side of the anterior space 3a in the light guide space 3, has prisms 12_{1,2} comprising flat plane 12a extending to a sufficient length toward the incident light beam from the bulb 4 and comprising refraction plane 12b that refracts incident light beams extending in the direction perpendicular to the surface of this paper, as shown in Figure 3. The fixture has a lighting plane 13 that is formed so that the overall shape would be serrated shape formed by these two rows of prisms 12_{1,2}. This lighting plane 13 is a characteristic component of this device. On the other hand, light can be accepted from the bulb 4 irradiated between the angle 12_c of one prism 12₁ and the lower side of the refraction plane 12b of the other prism 12₂. The lighting member area is formed so as to be great compared to the thickness of the light guide plate 5. In addition, the refraction planes 12b of each prism 12_{1,2} have a mutually parallel relationship. These refraction planes 12b accept light from the bulb 4 within the light guide plate 5. Here, the extension length of the flat planes 12a of each prism 12₁, 12₂ should be set so as to be several times greater than the amount of unevenness of the reflection member 7 that presents the aforementioned serrated shape. Consequently, the lighting member area attributable to both prisms 12₁, 12₂ is clearly large enough compared to prior devices. Furthermore, the flat plane 12a of the lower prism 12b located between the individual refraction planes 12b extends toward the incident light beam from the bulb 4 at that section. As a result, the incident light beam at this section is reliably accepted within the light guide plate 5 and is uniformly conducted to the tip side of the light guide plate 5. Furthermore, each refraction plane 12b is set so that light from the bulb 4 would be refracted and so that the refracted light beam would be irradiated at an incident angle greater than the critical angle (usually about 42 degrees)

on the outer surface 5a of the light guide plate 5. The materials comprising the light guide plate 5 may vary and the refraction plane 12b of the light guide plate 5 may be formed in conjunction with the critical angle that may change somewhat.

In such a structure, light 14 from the bulb 4 that had been accepted from the lighting member 6 of the light guide plate 5 is incident on the outer surface 5a of the light guide plate 5 at an incident angle θ ($\theta > 42^\circ$), as shown by the broken line in Figure 4. The reflected light beam is conducted to the tip of the light guide plate 5 and is reflected off the outer surface 5a of the light guide plate 5. The reflected light beam is reflected by the reflection member 7 at the tip of the light guide plate 5 and is conducted outward from the front lens 2.

Accordingly, as mentioned above, in the light guide plate 5 that is deployed from the anterior space 3a to the lateral space 3b of the light guide space 3, as shown in Figure 3, large amounts of optical power are accepted from the lighting member 6 and can be efficiently conducted to the tip of the light guide plate 5 with little reflection of the incident light beam. Furthermore, the optical power loss at the reflection section can be minimized.

In the aforementioned embodiment, the light guide plate 5 is welded to the front lens 8, but this device is not restricted to this. For example, the light guide plate 5 may be fixed to the side of the fixture body 1 as shown in Figure 5, or the entire external surface of the light guide plate 5 may be joined to the inside of the front lens 2, or the light guide plate 5 may be integrally formed with the front lens 2 as shown in Figure 6. Protrusions 2a, 2b need not be attached to the side of the front lens 2 as a result of adopting such a structure, and another benefit is the great enhancement in visibility.

Furthermore, the aforementioned embodiments are structured with a reflection member 7 having a serrated shape formed on the inside of the light guide plate 5, but this device is not restricted to this. For example, the same effects as in the aforementioned embodiment can be realized even with a reflection member in which the inside of the light guide plate has been coarsened via frosting or texturing. Furthermore, the light emitted from the front lens could be made brighter if a reflection surface is completed by affixing hot stamping, etc., to the inner surface of the light guide plate 5. Furthermore, in addition to forming a reflection member 7 on only the light guide plate 5 in the aforementioned embodiments, the formation of a reflection surface in sections of the fixture body 1 corresponding to the reflection member 7 of the light guide plate 5 as well would enable the brightness of the light issued from the front lens to be brighter and would enhance the visibility.

The lighting member 6 of the light guide plate 5 comprises two rows of prisms 12_{1,2} with a serrated shape in the aforementioned embodiments, but this device is not restricted to this. Numerous rows of prisms may be employed as well. In short, the lighting member of the light guide plate may be formed in serrated shape via prisms comprising a plane sufficiently elongated in the direction of the incident light beam and a refraction plane that refracts incident light beams. The lighting plane comprising individual refraction planes should have an area greater than the thickness of the base of the light guide plate.

As explained above, the lighting member of a light guide plate deployed within a light guide space is formed in serrated shape in the vehicle light fixture pursuant to the present device, and the area of the lighting plane is formed so as to be greater than the area of the base of the light guide plate. Consequently, the incident light beam that is accepted from the lighting plane is refracted at the refraction plane of the prism in this structure, and the incident angle when the refracted light beam strikes the outer plane of the light guide plate is greater than the critical angle. Consequently, light from the light source can be efficiently conducted to the tip of the light guide plate. Accordingly, the brightness of the light issued from the side of the light fixture can equal the brightness of the light issued from the front of the light fixture. Bright light can be derived uniformly over the entire surface of the front lens, and the visibility can be enhanced.

Brief Description of Drawings

Figure 1 to Figure 3 are partial cross-sectional views showing a conventional vehicle light fixture. Figure 4 to Figure 6 are partial cross-sectional views showing embodiments of the vehicle light fixture pursuant to the present device.

1.. fixture body, 2.. front lens, 3.. light guide space, 3a.. anterior space, 3b.. lateral space, 4.. bulb, 5.. light guide plate, 6.. lighting member, 7.. reflection member, 12.. prism, 12a.. flat plane, 12b.. refraction plane

Figure 1

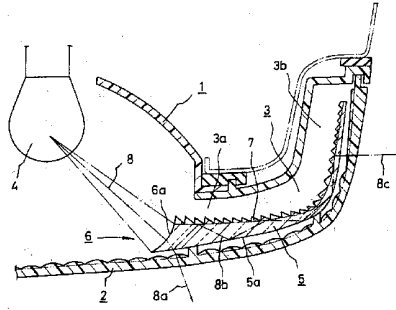

Figure 2

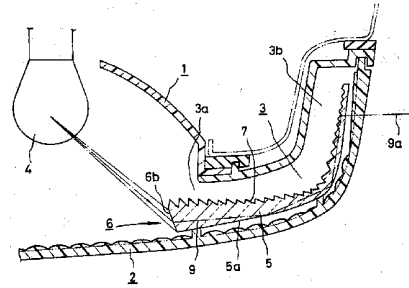
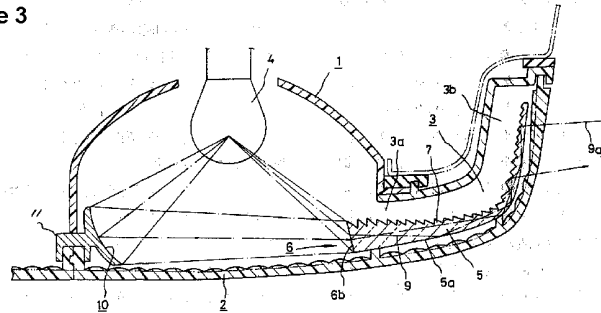

Figure 3



Explore Litigation Insights

Docket Alarm provides insights to develop a more informed litigation strategy and the peace of mind of knowing you're on top of things.

Real-Time Litigation Alerts



Keep your litigation team up-to-date with **real-time alerts** and advanced team management tools built for the enterprise, all while greatly reducing PACER spend.

Our comprehensive service means we can handle Federal, State, and Administrative courts across the country.

Advanced Docket Research



With over 230 million records, Docket Alarm's cloud-native docket research platform finds what other services can't. Coverage includes Federal, State, plus PTAB, TTAB, ITC and NLRB decisions, all in one place.

Identify arguments that have been successful in the past with full text, pinpoint searching. Link to case law cited within any court document via Fastcase.

Analytics At Your Fingertips



Learn what happened the last time a particular judge, opposing counsel or company faced cases similar to yours.

Advanced out-of-the-box PTAB and TTAB analytics are always at your fingertips.

API

Docket Alarm offers a powerful API (application programming interface) to developers that want to integrate case filings into their apps.

LAW FIRMS

Build custom dashboards for your attorneys and clients with live data direct from the court.

Automate many repetitive legal tasks like conflict checks, document management, and marketing.

FINANCIAL INSTITUTIONS

Litigation and bankruptcy checks for companies and debtors.

E-DISCOVERY AND LEGAL VENDORS

Sync your system to PACER to automate legal marketing.