

[54] TABLE ATTACHING CONSTRUCTION FOR NURSING CHAIRS

[75] Inventor: Kenzou Kassai, Osaka, Japan

[73] Assignee: Aprica Kassai Kabushikikaisha, Osaka, Japan

[21] Appl. No.: 893,479

[22] Filed: Aug. 5, 1986

[30] Foreign Application Priority Data

Aug. 14, 1985 [JP] Japan 60-124694

[51] Int. Cl.⁴ A47B 83/02

[52] U.S. Cl. 297/153; 292/30; 297/149

[58] Field of Search 297/148, 149, 151, 153; 292/29, 30, 52, 53, 127, 221

[56] References Cited

U.S. PATENT DOCUMENTS

- 1,123,331 1/1915 Loeber 292/30
- 1,556,524 10/1925 Kibble et al. 292/127
- 1,766,366 6/1930 Welch et al. 292/127 X
- 2,483,633 10/1949 Froelich 297/149
- 3,097,884 7/1963 Alford 297/153
- 3,649,074 3/1972 McDonald 297/153
- 4,105,247 8/1978 Saint 297/149
- 4,582,359 4/1986 Wise et al. 297/153 X

FOREIGN PATENT DOCUMENTS

- 461807 12/1949 Canada 297/149
- 21331 5/1981 Japan .

Primary Examiner—Kenneth J. Dorner
Assistant Examiner—Peter R. Brown
Attorney, Agent, or Firm—W. G. Fasse; D. H. Kane, Jr.

[57] ABSTRACT

A table attaching construction for nursing chairs has longitudinally extending right- and left-hand table support frames, a table disposed on these table support frames, and right- and left-hand operating levers. The right- and left-hand operating levers are adapted to be turned between first locking and second release positions. When the operating levers are each in the first position, they are in engagement with the outer lateral portions and lower portions of the table support frames. When the operating levers are each in the second position, such engagement is canceled. The table attaching construction for nursing chairs further includes right- and left-hand slide members, and springs for urging these slide members to slide inwardly. Each slide member has an opening for the associated operating lever to extend vertically therethrough. Under the action of the springs, the wall surfaces of the openings in the slide members press the operating levers to maintain the latter in the first locking position. If an operating lever provided on one side of the table is turned to the second position and then, in this state, if the table is pushed to move toward the other side, then the engagement between the pair of operating levers and the pair of table support frames is canceled and the table can be removed by one hand only.

7 Claims, 9 Drawing Figures

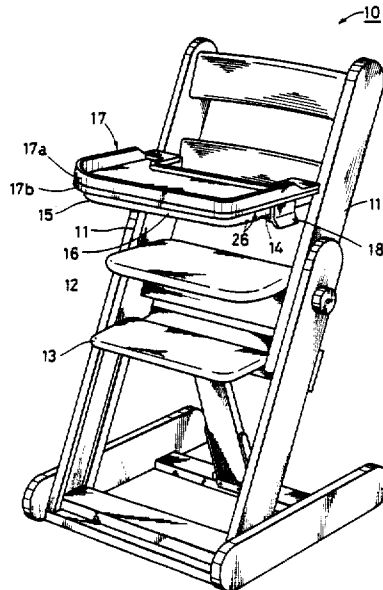

FIG. 1

10

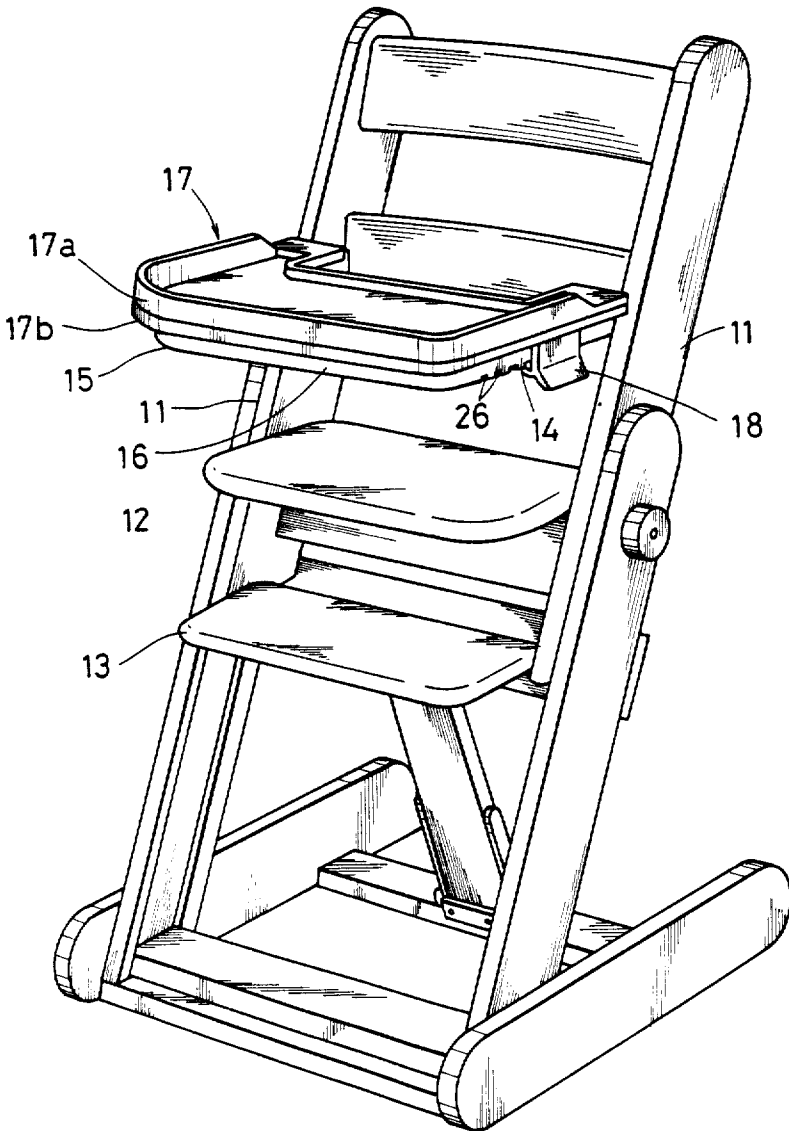

FIG. 2

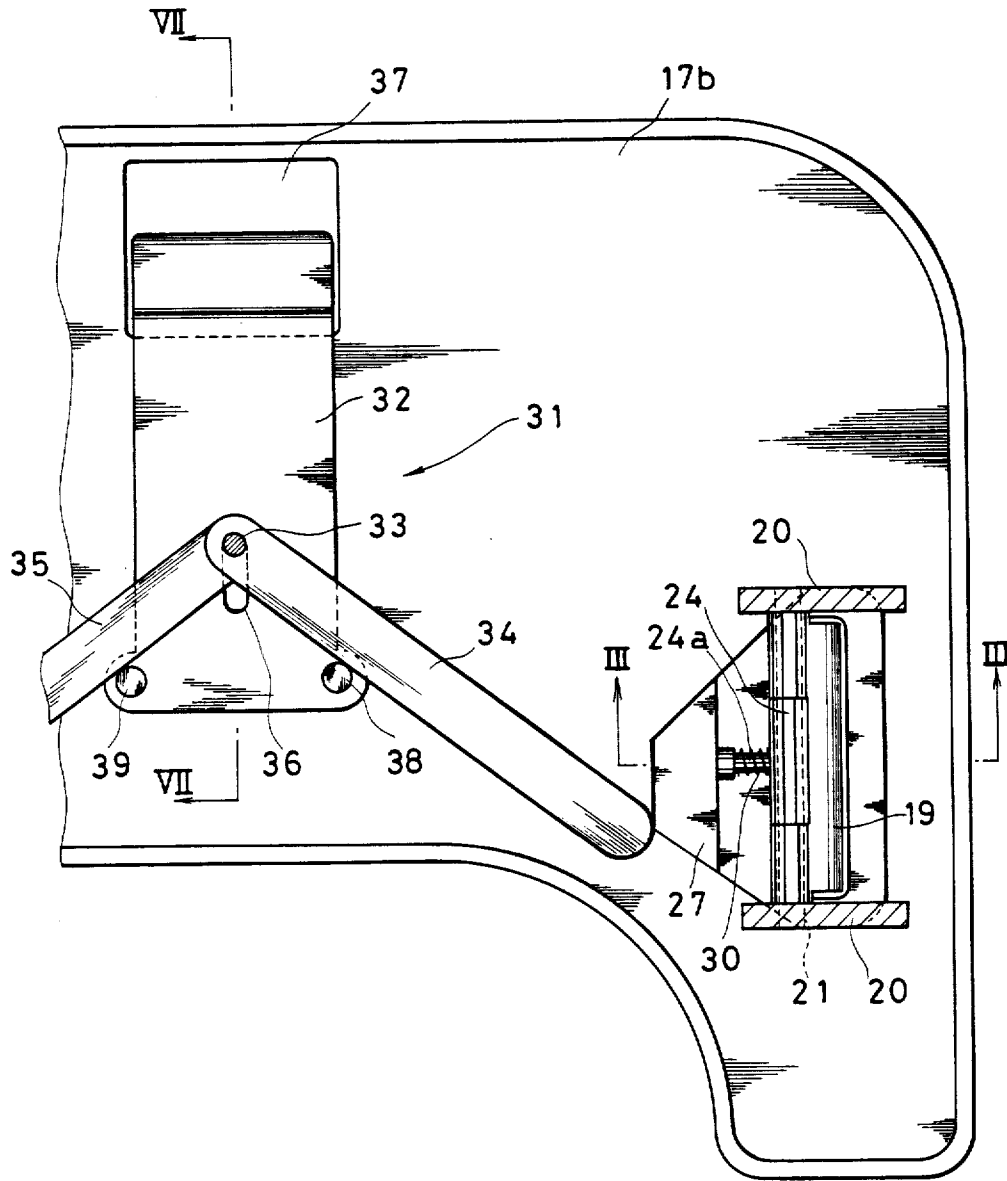

FIG. 3

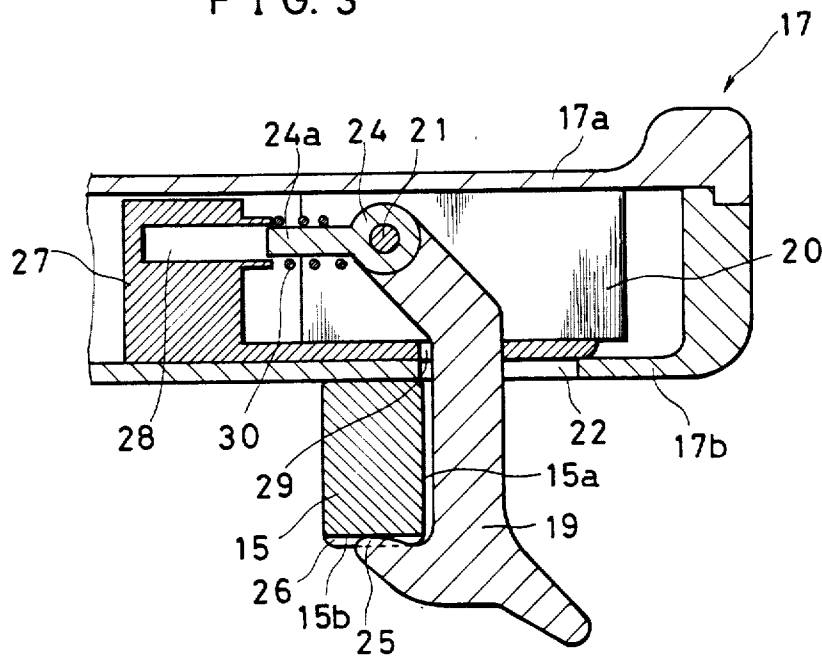

FIG. 6

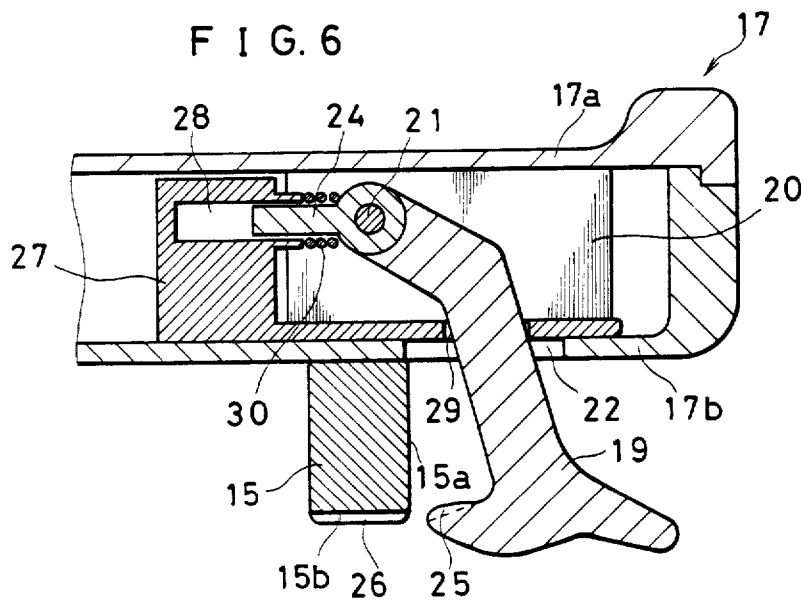

FIG. 4

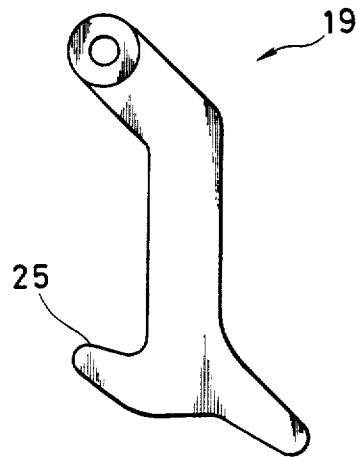
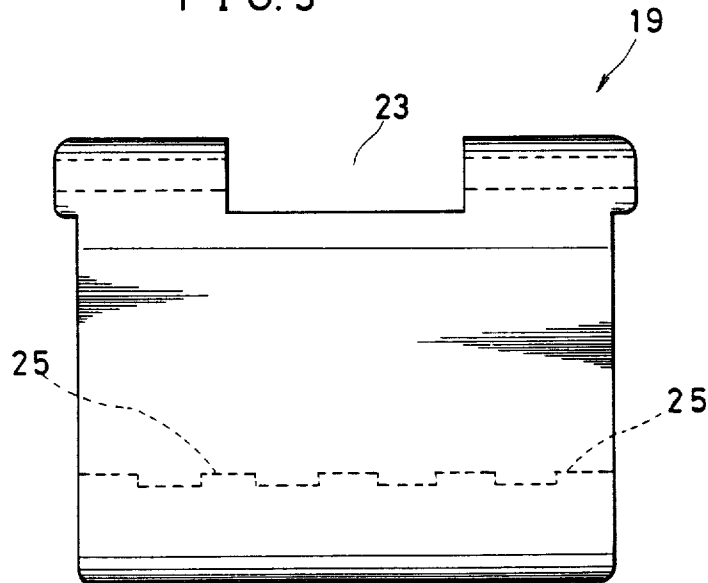

FIG. 5



Explore Litigation Insights

Docket Alarm provides insights to develop a more informed litigation strategy and the peace of mind of knowing you're on top of things.

Real-Time Litigation Alerts



Keep your litigation team up-to-date with **real-time alerts** and advanced team management tools built for the enterprise, all while greatly reducing PACER spend.

Our comprehensive service means we can handle Federal, State, and Administrative courts across the country.

Advanced Docket Research



With over 230 million records, Docket Alarm's cloud-native docket research platform finds what other services can't. Coverage includes Federal, State, plus PTAB, TTAB, ITC and NLRB decisions, all in one place.

Identify arguments that have been successful in the past with full text, pinpoint searching. Link to case law cited within any court document via Fastcase.

Analytics At Your Fingertips



Learn what happened the last time a particular judge, opposing counsel or company faced cases similar to yours.

Advanced out-of-the-box PTAB and TTAB analytics are always at your fingertips.

API

Docket Alarm offers a powerful API (application programming interface) to developers that want to integrate case filings into their apps.

LAW FIRMS

Build custom dashboards for your attorneys and clients with live data direct from the court.

Automate many repetitive legal tasks like conflict checks, document management, and marketing.

FINANCIAL INSTITUTIONS

Litigation and bankruptcy checks for companies and debtors.

E-DISCOVERY AND LEGAL VENDORS

Sync your system to PACER to automate legal marketing.