



US007420550B2

(12) **United States Patent**
Yuh-Ren et al.

(10) **Patent No.:** **US 7,420,550 B2**
(45) **Date of Patent:** **Sep. 2, 2008**

(54) **LIQUID CRYSTAL DISPLAY DRIVING DEVICE OF MATRIX STRUCTURE TYPE AND ITS DRIVING METHOD**

(75) Inventors: **Shen Yuh-Ren**, Tainan (TW); **Chen Cheng-Jung**, Miaoli Hsien (TW); **Chen Chun-Chi**, Kaohsiung (TW)

(73) Assignee: **Vast View Technology, Inc.**, Hsinchu (TW)

(*) Notice: Subject to any disclaimer, the term of this patent is extended or adjusted under 35 U.S.C. 154(b) by 677 days.

(21) Appl. No.: **10/929,473**

(22) Filed: **Aug. 31, 2004**

(65) **Prior Publication Data**

US 2006/0044292 A1 Mar. 2, 2006

(51) **Int. Cl.**
G09G 3/36 (2006.01)

(52) **U.S. Cl.** **345/204; 345/50; 345/90; 345/98; 345/103; 345/214; 349/143**

(58) **Field of Classification Search** **345/50; 345/58, 90, 93, 95, 98, 103, 204, 205, 214; 349/143**

See application file for complete search history.

(56) **References Cited**

U.S. PATENT DOCUMENTS

5,805,128 A * 9/1998 Kim et al. 345/96
6,057,904 A * 5/2000 Kim et al. 349/143
6,157,056 A * 12/2000 Takeuchi et al. 257/315
6,310,594 B1 * 10/2001 Libsch et al. 345/90
2004/0056331 A1 * 3/2004 Chen et al. 257/629

* cited by examiner

Primary Examiner—Bipin Shalwala

Assistant Examiner—Vince E Kovalick

(74) *Attorney, Agent, or Firm*—Lowe Hauptman Ham & Berner, LLP

(57) **ABSTRACT**

A liquid crystal display driving device of matrix structure type and its driving method are disclosed in the present invention. The driving device consists of a group of thin film transistors with matrix array, a plurality of gate lines and a plurality of data lines. The object of increasing response speed can be accomplished by the different arrangement of gate lines and data lines and the different connection between each thin film transistor and the gate and data lines. The driving method for the said driving device includes: each pair of gate lines in the display panel are simultaneously and orderly turned on at different time of driving transistor, and the different driving voltages are orderly applied to the thin film transistors connected to the gate lines. The structure and method can suit for picture treating of various displays such as liquid crystal display, organic light-emitting diode (OLED) display or plasma display panel (PDP).

7 Claims, 26 Drawing Sheets

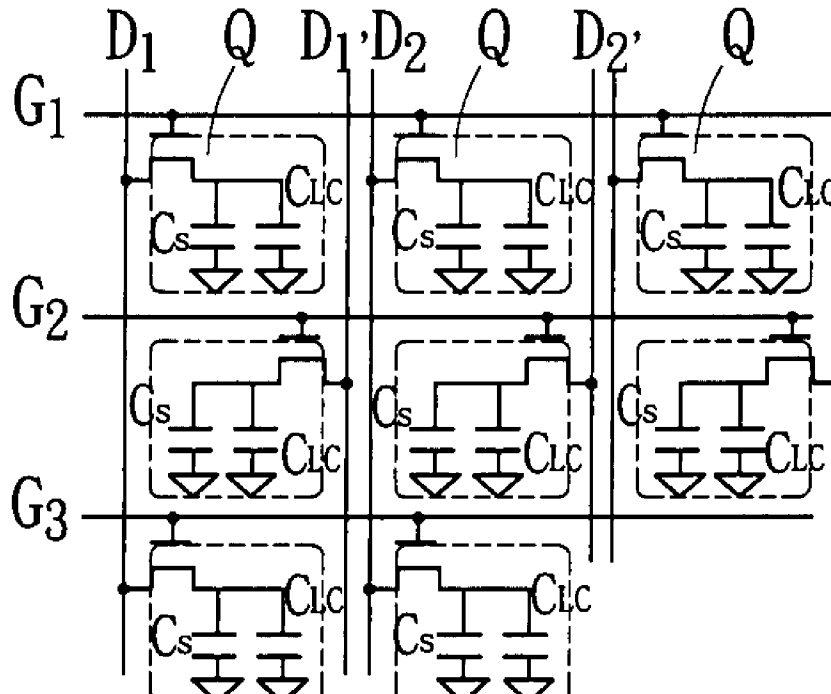

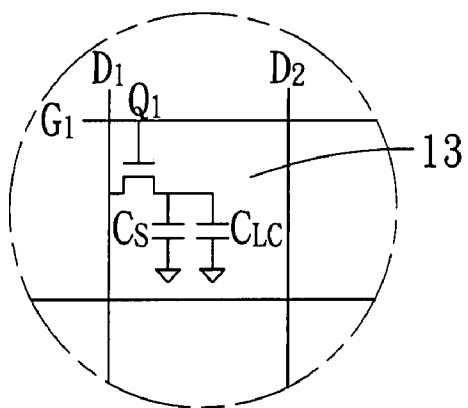

Fig. 1B (Prior Art)

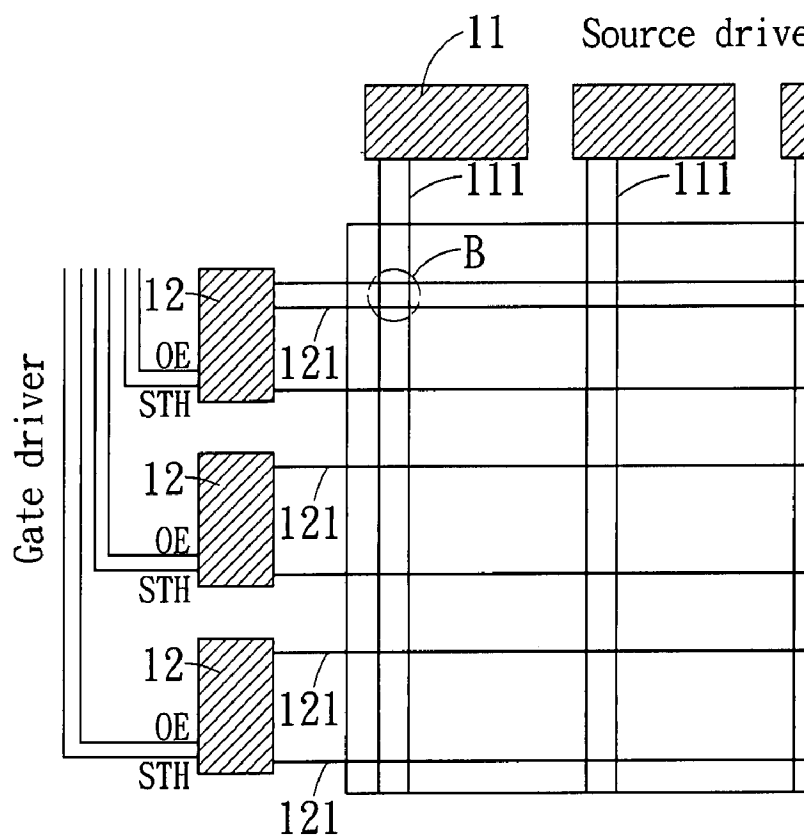

Fig. 1A (Prior Art)

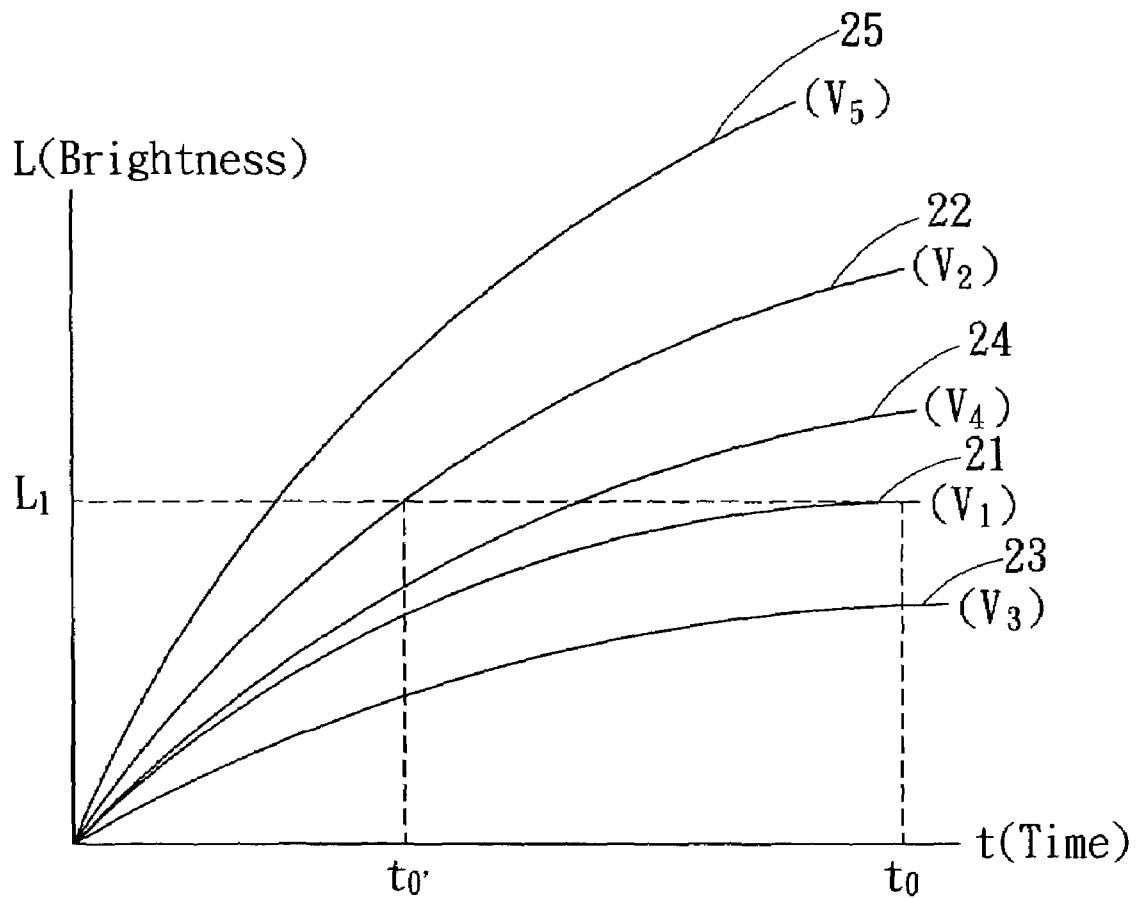

Fig. 2 (Prior Art)

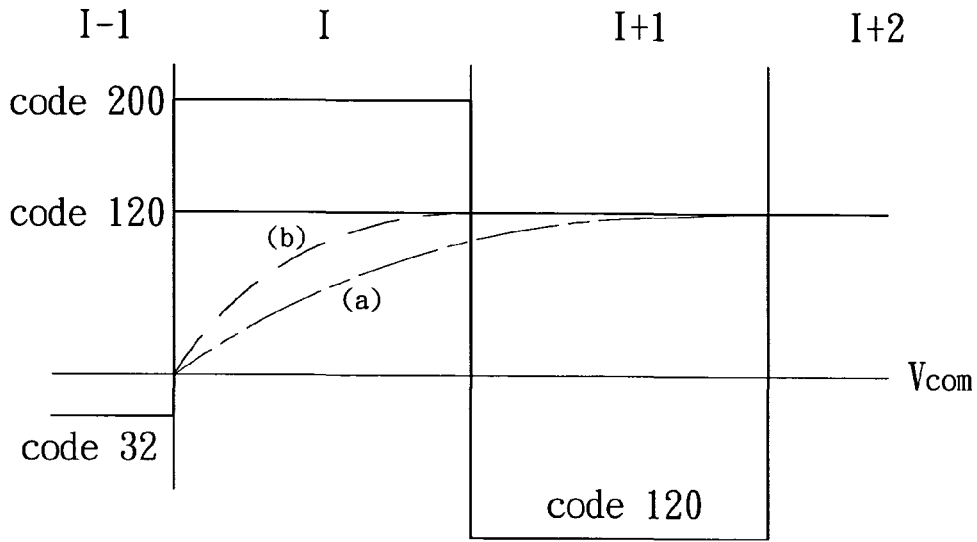

Fig. 3A (Prior Art)

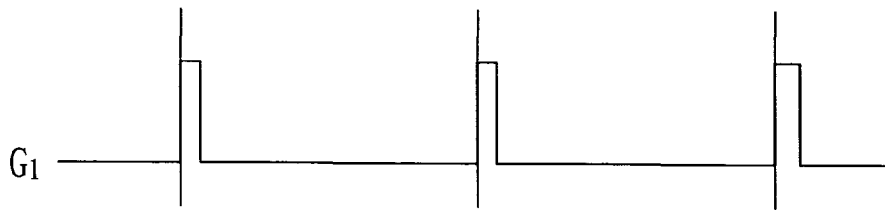

Fig. 3B (Prior Art)

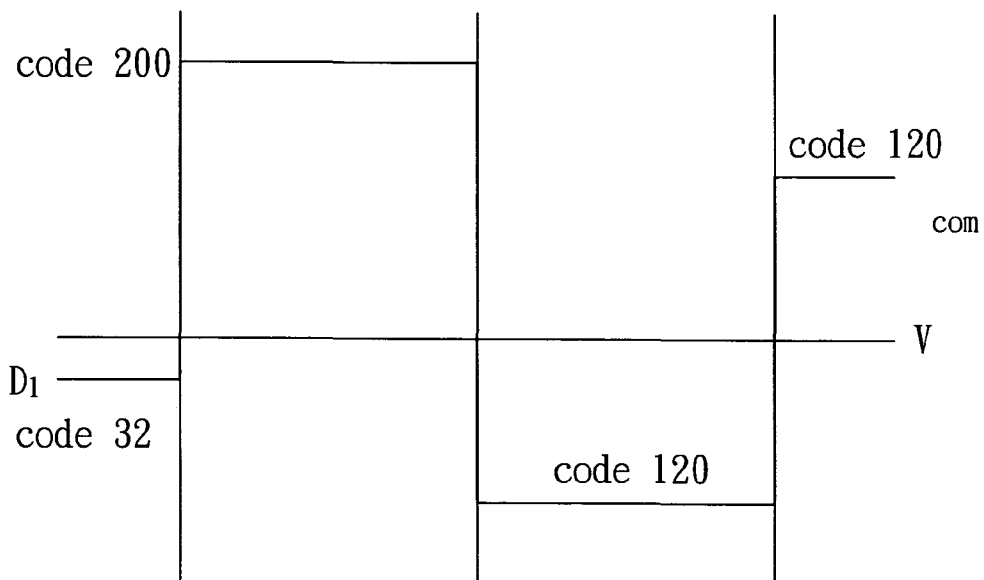

Fig. 3C (Prior Art)

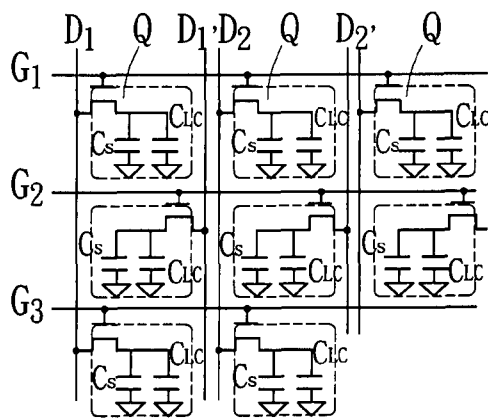

Fig. 4B

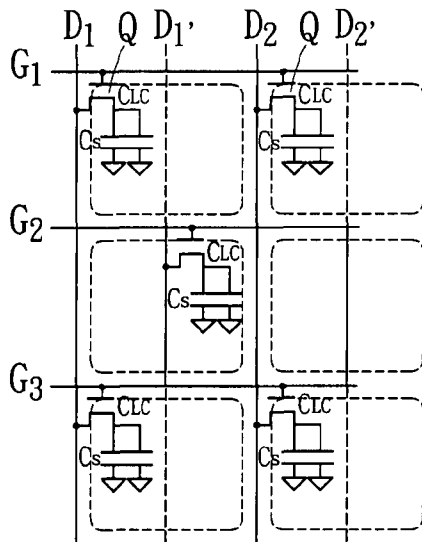

Fig. 4C

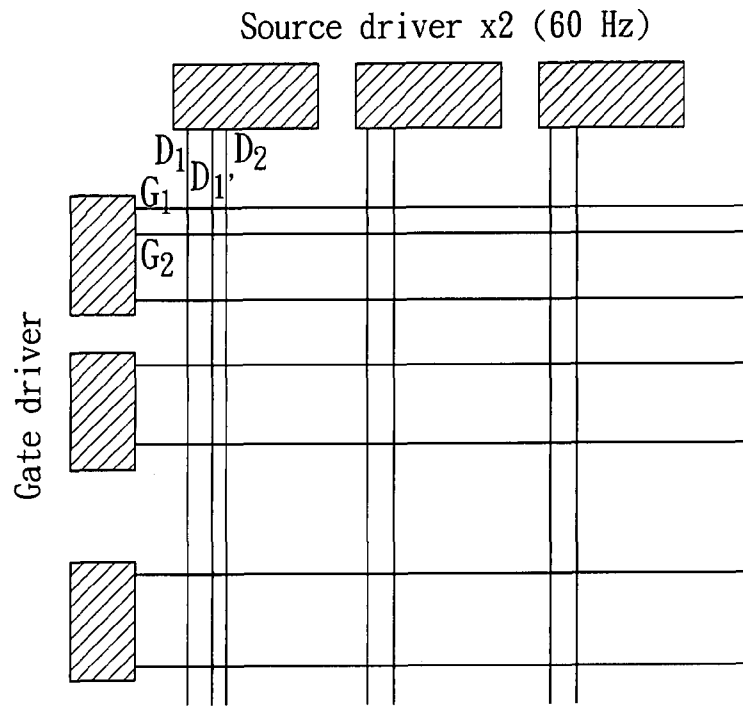

Fig. 4A

Explore Litigation Insights

Docket Alarm provides insights to develop a more informed litigation strategy and the peace of mind of knowing you're on top of things.

Real-Time Litigation Alerts



Keep your litigation team up-to-date with **real-time alerts** and advanced team management tools built for the enterprise, all while greatly reducing PACER spend.

Our comprehensive service means we can handle Federal, State, and Administrative courts across the country.

Advanced Docket Research



With over 230 million records, Docket Alarm's cloud-native docket research platform finds what other services can't. Coverage includes Federal, State, plus PTAB, TTAB, ITC and NLRB decisions, all in one place.

Identify arguments that have been successful in the past with full text, pinpoint searching. Link to case law cited within any court document via Fastcase.

Analytics At Your Fingertips



Learn what happened the last time a particular judge, opposing counsel or company faced cases similar to yours.

Advanced out-of-the-box PTAB and TTAB analytics are always at your fingertips.

API

Docket Alarm offers a powerful API (application programming interface) to developers that want to integrate case filings into their apps.

LAW FIRMS

Build custom dashboards for your attorneys and clients with live data direct from the court.

Automate many repetitive legal tasks like conflict checks, document management, and marketing.

FINANCIAL INSTITUTIONS

Litigation and bankruptcy checks for companies and debtors.

E-DISCOVERY AND LEGAL VENDORS

Sync your system to PACER to automate legal marketing.