

PRAMANA

— journal of
physics

Special issue on

Liquid Crystals and Other Soft Materials

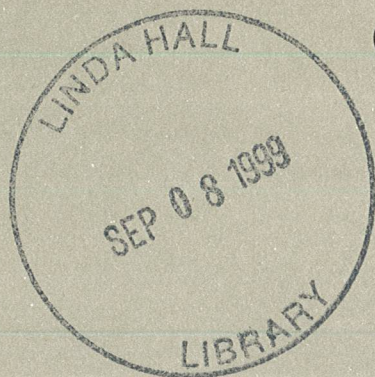

Volume 53 No. 1
July 1999

INDIAN ACADEMY OF SCIENCES

Indian National Science Academy
Indian Physics Association



Pramana – journal of physics

Editor

H R Krishnamurthy
Indian Institute of Science, Bangalore

Associate Editor

Rohini M Godbole
Indian Institute of Science, Bangalore

Editorial Board

J K Bhattacharjee, *Indian Assoc. for the Cultivation of Science, Calcutta*
Neelima Gupte, *Indian Institute of Technology, Chennai*
S Kailas, *Bhabha Atomic Research Centre, Mumbai*
Dilip G Kanhere, *University of Pune, Pune*
A V Khare, *Institute of Physics, Bhubaneswar*
C Manohar, *Mumbai*
Deepak Mathur, *Tata Institute of Fundamental Research, Mumbai*
S Mohan, *Indian Institute of Science, Bangalore*
Debashis Mukherjee, *Indian Assoc. for the Cultivation of Science, Calcutta*
Sunil Mukhi, *Tata Institute of Fundamental Research, Mumbai*
Rajaram Nityananda, *Raman Research Institute, Bangalore*
R Ramaswamy, *Jawaharlal Nehru University, New Delhi*
A K Raychaudhuri, *National Physical Laboratory, New Delhi*
K C Rustagi, *Centre for Advanced Technology, Indore*
E V Sampathkumaran, *Tata Institute of Fundamental Research, Mumbai*
Abhijit Sen, *Institute for Plasma Research, Gandhinagar*
Dinesh Sharma, *Indian Institute of Technology, Mumbai*
R Simon, *Institute of Mathematical Science, Chennai*
K Subramanian, *National Centre for Radioastronomy, Pune*
C S Sundar, *Indira Gandhi Centre for Atomic Research, Kalpakkam*

Editor of Publications of the Academy

N Mukunda
Indian Institute of Science, Bangalore

Annual Subscription Rates

All countries except India (Price includes AIR MAIL charges)	US\$ 200
India	Rs. 200

Annual subscriptions for individuals for India and abroad are Rs. 100/- and \$50 respectively.

All correspondence regarding subscription should be addressed to the Circulation Department of the Academy

Editorial Office

Indian Academy of Sciences, C V Raman Avenue,
P.B. No. 8005, Bangalore 560 080, India

Telephone: 80-334 2546
Telefax: 91-80-334 6094

Website: <http://www.iisc.ernet.in/pramana/>

Email: pramana@ias.ernet.in

© 1999 by the Indian Academy of Sciences. All rights reserved.

“Information for contributors” is printed in the last issue of every volume.

As part of the Gold Meeting on Liquid December 1998. Se topics, which inclu water and biologic delivered by Prof. About 100 particip and post docs selec for their benefit d topics which wou proceedings contai

Co-operation fro school and the disc Raman Research I colleagues, in partic V A Raghunathan a organization of the crystal laboratory, p Research Institute I

Our most gratef The lectures in the a Sadashiva, K A Su V Lakshminaraya M Muthukumar o Hindu University, A Jawaharlal Nehru C

Finally, our than making this public

**Special Issue on Liquid Crystals and
Other Soft Materials**

Contents

Preface	1
Quasi-one dimensional electrical conductivity and thermoelectric power studies on a discotic liquid crystal. V S K Balagurusamy, S Krishna Prasad, S Chandrasekhār, Sandeep Kumar, M Manickam and C V Yelamagad	3
The fragmented state of lipid bilayers in water: Discovery of a lower consolute point	13
W Helfrich, B Klösgen and J Thimmel	
Surface controlled nematic bistability	25
I Dozov and G Durand	
Surface adsorption and collapse transition of linear polymer chains	37
Yashwant Singh, Sanjay Kumar and Debaprasad Giri	
Liquid water: A very complex fluid	53
H Eugene Stanley	
Biology and the flow of molecular information	85
A J Libchaber	
Phase transitions in Langmuir monolayers	93
K A Suresh and A Bhattacharyya	
The lamellar and sponge phases of dilute surfactant systems: Structures and defects at equilibrium and under shear	107
Maurice Kleman	
Phase separated composite films of liquid crystals	121
Valery Vorflusev, Jae-Hoon Kim and Satyendra Kumar	
Natural optical activity and liquid crystals	131
C Oldano and M Becchi	
An LCD for the multimedia network age: Polymer stabilized FLC.	145
Shunsuke Kobayashi, Hirokazu Furue and Taiju Takahashi	
On the 'Listeria' propulsion mechanism	155
F Gerbal, V Noireaux, C Sykes, F Jülicher, P Chaikin, A Ott, J Prost, R M Golsteyn, E Friederich, D Louvard, V Laurent and M F Carlier	
Structure and dynamics of charged macromolecules: Minimal representation of biological systems.	171
M Muthukumar	

(Continued on inside back cover)

Driving matrix liquid crystal displays	<i>T N Ruckmongathan</i>	199
Molecular structure and chiral liquid crystalline phases	<i>B K Sadashiva</i>	213
Linear and nonlinear rheology of wormlike micelles	<i>A K Sood, Ranjini Bandyopadhyay and Geetha Basappa</i>	223
Nonequilibrium noise and instabilities in membranes with active pumps	<i>Sriram Ramaswamy, John Toner and Jacques Prost</i>	237

depending neither
precisely as seen
in form $T/\kappa k^4$ is
(the analogue in
of the curvature-

a linearly stable,
active membrane
response can mimic
of the observations
departures from the
predictions, including
we have merely
ones. A complete
of behaviour in the

Rao for valuable

(New York, 1995)
(New York, 1982)

(1998)
4356-4359 (1999)
of such a structural
component membranes

(1992)

(Oxford, 1986)

Indexed in CURRENT CONTENTS

ISSN 0304-4289

Edited and published by N Mukunda for the Indian Academy of Sciences, Bangalore 560 080.
Printed at Tholasi Prints India, Bangalore

Driving matrix liquid crystal displays

T N RUCKMONGATHAN

Raman Research Institute, C.V. Raman Avenue, Bangalore 560 080, India

Abstract. Liquid crystal displays had a humble beginning with wrist watches in the seventies. Continued research and development in this multi-disciplinary field have resulted in displays with increased size and complexity. After three decades of growth in performance, LCDs now offer a formidable challenge to the cathode ray tubes (CRT).

A major contribution to the growth of LCD technology has come from the developments in addressing techniques used for driving matrix LCDs. There are several approaches like passive matrix addressing, active matrix addressing and plasma addressing to drive a matrix display.

Passive matrix LCD has a simple construction and uses the intrinsic non-linear characteristic of the LCD for driving. Departure from conventional line by line addressing of a passive matrix has resulted in improved performance of the display. Orthogonal functions have played a crucial role in the development of passive matrix addressing. Simple orthogonal functions that are useful for driving a matrix LCD are introduced. The basics of driving several rows simultaneously (multi-line addressing) are discussed by drawing analogies from multiplexing in communication. The impact of multi-line addressing techniques on the performance of the passive matrix LCDs in comparison with the conventional technique will be discussed.

Keywords. Addressing; multiplexing.

PACS Nos 42.79.kr; 85.60.Bt; 85.60.pg

1. Introduction

Liquid crystal displays (LCDs) are the most popular among the various flat panel displays. LCDs operate at low voltages and need negligible power. This has led to their use in watches and calculators. However, limited viewing angle characteristics, large response times and limitations in the electro-optic characteristics were some of the drawbacks of LCD's for large information content displays like television and video displays. Considerable research and development during the last two decades were devoted towards overcoming these limitations in LCDs. Performance of LCDs is now comparable to that of CRT. However, they cost more as compared to CRT. Drive techniques are an important component in these developments. Objective of this paper is to discuss various methods for driving a matrix LCD.

2. Matrix displays and multiplexing

Any flat panel display consists of an array of picture elements (pixel) arranged as a rectangular matrix. In a matrix LCD the row and column electrodes are perpendicular to each other. Area of intersection of the row and column electrode defines a pixel. A row electrode and a column electrode uniquely address a pixel as shown in figure 1. Multiplexing or

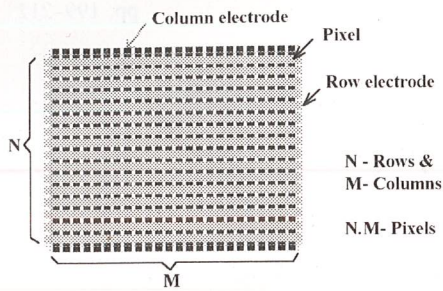

Figure 1. Schematic of a matrix LCD.

matrix addressing is the technique for driving matrix displays. The term multiplexing is derived from communication where several signals are multiplexed over a single channel. Matrix addressing is very similar, since the information for pixels in a column is multiplexed through the column electrode. Matrix addressing may use the intrinsic non-linear electro-optic characteristics of LCD. Figure 2 shows the typical non-linear electro-optic characteristics of twisted nematic (TN) and super twisted nematic (STN) LCDs. LCDs usually have a threshold voltage below which there is no change in its optical response. Similarly there is practically no change in transmission when voltages applied to the LCD is above the saturation voltage. Light transmission through the cell varies as the voltage applied to the LCD is increased from threshold to saturation voltages. For the sake of convenience, threshold voltage by definition is the voltage when there is 10% change in light transmission from the unexcited state. Similarly the saturation voltage is the voltage when the light transmission changes by 90%. Displays using this intrinsic non-linearity are called passive matrix LCDs, in contrast to active matrix LCDs wherein an additional non-linear element such as diode or a transistor is used in conjunction with each pixel. Plasma addressing is yet another approach that is becoming popular for driving matrix LCDs.

3. Passive matrix LCDs

Passive matrix displays exploit the intrinsic non-linearity of the LCD [1]. Figure 3 illustrates the schematic of a passive matrix LCD. An equivalent circuit of a 2 × 2 matrix LCD, when a voltage is applied between a row and column electrode while the other two electrodes are left floating is shown in figure 4. A part of the voltage applied to the selected pixel P_{11} will also appear across the non-selected pixels (P_{12} , P_{21} , P_{22}). Therefore floating electrodes must be avoided in a matrix display to prevent such cross-talk. LCDs are slow responding devices (response time ranges from a few to few hundred milliseconds). Hence, the RMS voltage of the applied electric field characterises the response of LCD rather than the instantaneous voltage across a pixel.

4. Orthogonal functions

A set of functions are orthogonal to each other when:

$$\int f_i(\theta)f_j(\theta)d\theta = \text{constant for } i = j \text{ and is equal to zero when } i \neq j. \quad (1)$$

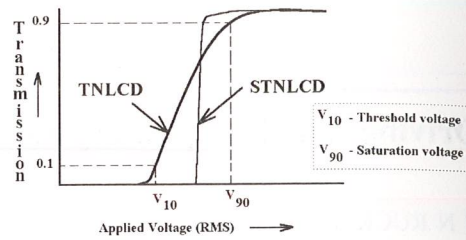

Figure 2. Typical electro-optic characteristic of TN and STN LCD's.

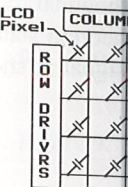

Figure 3. Schematic of

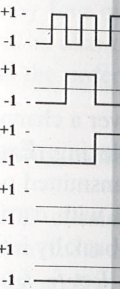

Figure 5. A

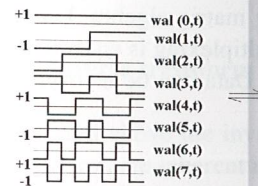
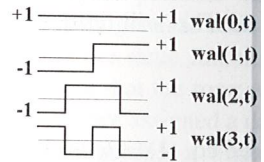

Figure 6. Walsh function orthogonal matrices.

A set of sine (or cosine) functions are orthogonal to each other. However, a set of orthogonal functions can be generated using the Walsh Transform using these cosine functions. The set of these functions is just a set of square waves of different frequencies decreasing (

LCD

V_{10} - Threshold voltage
 V_{90} - Saturation voltage

-optic characteristic

multiplexing is
 r a single channel.
 s in a column is
 the intrinsic non-
 non-linear electro-
 atic (STN) LCDs.
 nge in its optical
 voltages applied to
 e cell varies as the
 tages. For the sake
 e is 10% change in
 tage is the voltage
 ic non-linearity are
 an additional non-
 each pixel. Plasma
 g matrix LCDs.

CD [1]. Figure 3
 t of a 2 x 2 matrix
 while the other two
 age applied to the
 '21, P22). Therefore
 h cross-talk. LCDs
 ew hundred milli-
 erises the response

when $i \neq j$. (1)

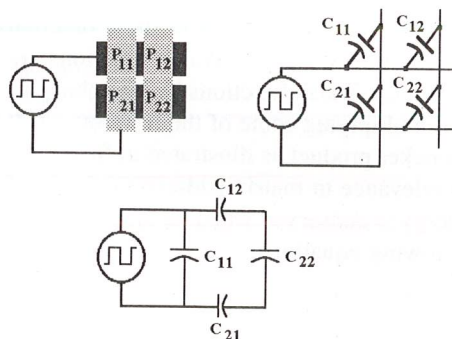
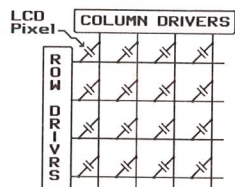

Figure 3. Schematic of a passive matrix LCD. Figure 4. Cross-talk in matrix LCD's.

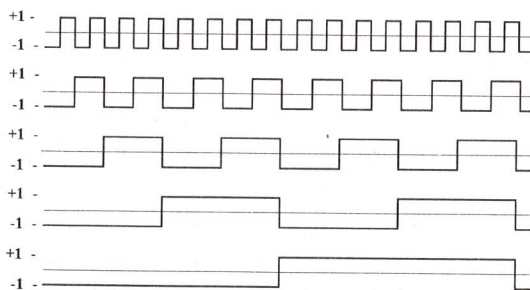
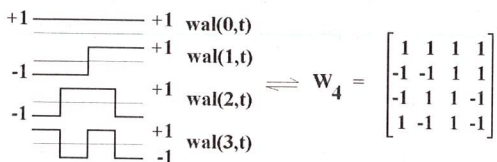
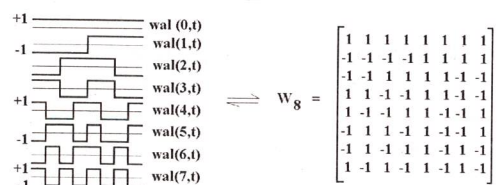

Figure 5. A set of Rademacher functions which are orthogonal.



$$H_1 = [1]; \quad H_2 = \begin{bmatrix} 1 & 1 \\ 1 & -1 \end{bmatrix};$$

$$H_4 = H_2 \otimes H_2 = \begin{bmatrix} H_2 & H_2 \\ H_2 & -H_2 \end{bmatrix} = \begin{bmatrix} 1 & 1 & 1 & 1 \\ 1 & -1 & 1 & -1 \\ 1 & 1 & -1 & -1 \\ 1 & -1 & -1 & 1 \end{bmatrix}$$



$$H_8 = H_2 \otimes H_4 = \begin{bmatrix} 1 & 1 & 1 & 1 & 1 & 1 & 1 & 1 \\ 1 & -1 & 1 & -1 & 1 & -1 & 1 & -1 \\ 1 & 1 & -1 & -1 & 1 & 1 & -1 & -1 \\ 1 & -1 & -1 & 1 & 1 & -1 & -1 & 1 \\ 1 & 1 & 1 & 1 & -1 & -1 & -1 & -1 \\ 1 & -1 & 1 & -1 & -1 & 1 & -1 & 1 \\ 1 & 1 & -1 & -1 & -1 & 1 & -1 & 1 \\ 1 & -1 & -1 & 1 & -1 & 1 & -1 & 1 \end{bmatrix}$$

Figure 6. Walsh functions and the corresponding orthogonal matrices.

Figure 7. Hadamard matrices.

A set of sine (or cosine) functions for example $\sin(2\pi nft)$; $n = 1, 2, \dots$ are orthogonal to each other. However, Rademacher functions and Walsh functions are much simpler sets of orthogonal functions [2,3]. These functions take just two values (+1 and -1). Transform using these orthogonal functions need no multiplication since the amplitudes of these functions is just unity. Hence they are important for hardware realisation of the circuits. Figure 5 illustrates a set of Rademacher functions. They are square waves with frequencies decreasing (or increasing) by a factor of two. The Walsh functions are shown

in figure 6. Orthogonality of these functions is not altered when some of these functions are multiplied by -1 . Walsh functions are related to Hadamard matrices. It is easy to obtain the Walsh functions by interchanging the rows and columns of Hadamard matrices and multiplying some of the rows by -1 . It is easy to generate Hadamard matrices using kroneker product as illustrated in figure 7. Parsaval's theorem of orthogonal transforms is of relevance in matrix addressing. In simple terms the Parsaval's theorem states that the energy is conserved when an orthogonal transform is taken on any signal as shown in the following equations.

$$\frac{1}{T} \int_T x^2(t) dt = \frac{C}{T} \sum_{n=0}^{\infty} a_n^2,$$

wherein a_n 's are the transform coefficients and C is a constant.

5. Multiplexing and demultiplexing

Multiplexing is a technique for transmitting more than one signal over a channel. Figure 8 shows the general block diagram of multiplexing and de-multiplexing. Each signal is multiplied with a carrier. The sum of these multiplied signals is transmitted over a single channel. At the receiving end the multiplexed signal is multiplied with carriers that are replica of the carriers at the transmitting end. Signals are recovered back by integrating the output of the multipliers. The carriers are orthogonal to each other. Let f_1, f_2, \dots, f_N be a set of N orthogonal functions. Let d_1, d_2, \dots, d_N be the data to be transmitted. Multiplexed signal is given by $(f_1 \cdot d_1 + f_2 \cdot d_2 + \dots + f_N \cdot d_N)$. At the receiving end d_i can be recovered by multiplying the multiplexed signal with f_i followed by integration. This will result in

$$\int f_i \cdot (f_1 \cdot d_1 + f_2 \cdot d_2 + \dots + f_N \cdot d_N) dt = \int f_i^2 d_i dt.$$

Integral of f_i^2 is unity by the definition of orthogonal function (see eq. (1)). Hence the signal or data d_i is recovered.

Multiplexing and de-multiplexing may also be illustrated using matrix algebra. Let O be the orthogonal matrix. Let D be the data to be multiplexed. Multiplexing is equivalent to taking the orthogonal transform of the data, that is $M = O \cdot D$. Data can be recovered

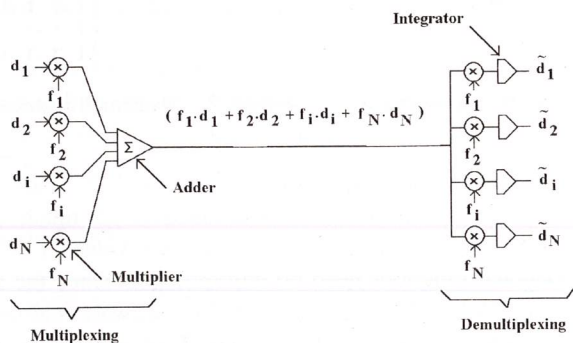

Figure 8. Schematic multiplexing and demultiplexing.

$$O = \begin{bmatrix} 1 & 1 \\ 1 & -1 \\ 1 & -1 \\ 1 & -1 \end{bmatrix}$$

$$D = \frac{1}{4} O^{-1} O$$

Figure 9.

back by multiplying $M = O^{-1} \cdot O \cdot D = I \cdot D$. Here a four by four O of the matrix is also wherein n is the orde

6. Multiplexing ma

A matrix LCD consi passive matrix LCD upon how the matrix scanning electrodes Repetitive periodic w are orthogonal to each serve the same functi assume that the rows Pixels are assigned a c pixels getting a high Orthogonal transform

7. Inverse transform

As seen above the inv functions are inherent

Let f_1, f_2, \dots, f_N be displayed in a given c $f_N \cdot d_N$ Let $k \cdot f_1, k \cdot f_2, \dots$ matrix display. The rc

$$V_{RMS} =$$

$$V_{RMS} =$$

Driving matrix liquid crystal displays

$$O = \begin{bmatrix} 1 & 1 & 1 & 1 \\ 1 & 1 & -1 & -1 \\ 1 & -1 & -1 & 1 \\ 1 & -1 & 1 & -1 \end{bmatrix}; \quad D = \begin{bmatrix} a \\ b \\ c \\ d \end{bmatrix}; \quad M = OD = \begin{bmatrix} a+b+c+d \\ a+b-c-d \\ a-b-c+d \\ a-b+c-d \end{bmatrix}$$

$$D = \frac{1}{4} O^{-1} M = \frac{1}{4} \begin{bmatrix} 1 & 1 & 1 & 1 \\ 1 & 1 & -1 & -1 \\ 1 & -1 & -1 & 1 \\ 1 & -1 & 1 & -1 \end{bmatrix} \begin{bmatrix} a+b+c+d \\ a+b-c-d \\ a-b-c+d \\ a-b+c-d \end{bmatrix} = \begin{bmatrix} a \\ b \\ c \\ d \end{bmatrix}$$

Figure 9. Illustration of multiplexing and demultiplexing using orthogonal matrix.

back by multiplying M by the inverse of the orthogonal transform matrix O . $D = O^{-1}M$, $M = O^{-1}OD = ID$, where I is the unit matrix. An example is illustrated in figure 9. Here a four by four orthogonal matrix is used for multiplexing four signals. The inverse of the matrix is also the same, since the matrix is symmetric. A scaling factor $(1/\sqrt{n})$, wherein n is the order of the square matrix is used to ensure that $O.O^{-1}$ is unit matrix.

6. Multiplexing matrix LCDs

A matrix LCD consists of row electrodes and column electrodes. An RMS responding passive matrix LCD is a crude form of demultiplexer as explained below. Depending upon how the matrix is scanned one set of electrodes (row or column) is called the scanning electrodes while the other set of electrodes is called the data electrodes. Repetitive periodic waveforms are applied to the scanning electrodes. These waveforms are orthogonal to each other and are independent of the information to be displayed. They serve the same function as carrier in communication. For the sake of simplicity we can assume that the rows are scanned and data is multiplexed through the column electrodes. Pixels are assigned a data +1 for OFF pixels and -1 for ON pixels. This will result in ON pixels getting a higher root-mean-squared voltage as compared to the OFF pixels. Orthogonal transform of the data in a column is applied as the column waveform.

7. Inverse transform using RMS responding device

As seen above the inverse transform requires multiplication and integration. Both these functions are inherent in a root-mean square responding device like LCD as shown below.

Let f_1, f_2, \dots, f_N be a set of N orthogonal functions. Let d_1, d_2, \dots, d_N be the data to be displayed in a given column. Column waveform for this column is $(f_1.d_1 + f_2.d_2 + \dots + f_N.d_N)$ Let $k.f_1, k.f_2, \dots, k.f_N$ be the N orthogonal waveforms applied to the rows of the matrix display. The root mean squared voltage across a pixel in row i will be

$$V_{RMS} = \sqrt{\left(\int (k f_i - (f_1.d_1 + f_2.d_2 + \dots + f_N.d_N))^2 dt \right)}$$

$$V_{RMS} = \sqrt{\int (k^2 f_i^2) dt - 2k \int f_i^2 d_i dt + \int (f_1.d_1 + f_2.d_2 + \dots + f_N.d_N)^2 dt}$$

$$V_{RMS} = \sqrt{\int k^2 f_i^2 dt - 2k \int d_i f_i^2 dt + N \text{ since } \int (d_i f_i)^2 dt \text{ is } 1.}$$

First and last term in the above expression are constants and the middle term is the product term useful for demultiplexing. Ratio of root-mean-square voltage across an ON pixel to that across an OFF pixel is called the selection ratio. This is a measure of the discrimination between the ON and OFF pixels and is an indirect method of estimating the contrast in the display. A high selection ratio is desirable to obtain a high contrast in the display.

For the maximum selection ratio the first term is equal to the last term. Hence $k = \sqrt{N}$. RMS voltage across the pixel will be proportional to $(2N - 2\sqrt{N}d_i)$ and the maximum (SR) is

$$SR = \sqrt{(\sqrt{N} + 1)/(\sqrt{N} - 1)}. \tag{2}$$

Selection ratio is infinite for $N = 1$ and rapidly falls as N increases. For example $SR = 1.105$ when $N = 100$, which means that there is just 10% difference in RMS voltages between ON and OFF pixels.

8. Line by line addressing

One of the early driving scheme is the line by line addressing [4] where in the rows of a matrix display are sequentially selected one at a time. Figure 10 illustrates the conventional line by line addressing of passive matrix LCD. Orthogonal matrix used here is a unit matrix with 1 as the diagonal elements. Column signal is the data itself as the orthogonal transform of the data is same as the data. The corresponding row and column waveforms are shown in figure 10. Both the row and column waveforms are inverted after a time period T , when addressing is complete. This ensures that no dc field is present across the pixels in the display. While a display may be driven by dc fields the life of the display will be reduced due to migration of ions towards the electrodes and slow electrochemical reactions in the display cell. The line by line addressing technique gives

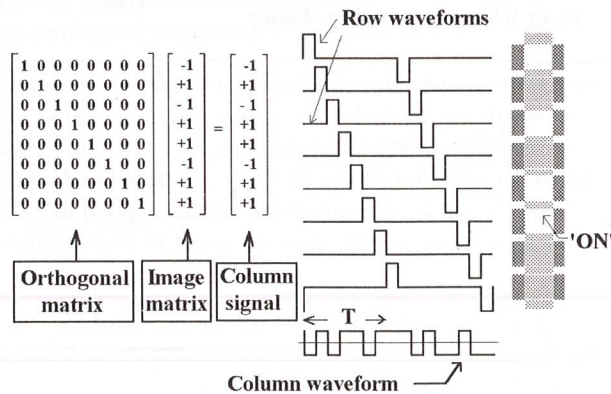

Figure 10. Illustration of the conventional line by line addressing of a passive matrix LCD.

a maximum selective waveform to amplitude that are multiplexed. The instantaneous voltage of the liquid crystal is maintained below threshold. LCDs are slow devices, milliseconds. Hence, the Period (T) of the addressing is several times of the LCD. Hundreds of times the period may be addressed line by line addressing to maintain contrast in the display.

9. Frame response

Under optimum conditions, the waveforms delivered through the display (energy from the row and column threshold voltage). This results in poor contrast. Frame response is a measure of the contrast.

One of the techniques for improving contrast is described below.

10. Active addressing

Active addressing uses active elements in all the rows are similar to the column functions. The column data to be displayed. S

Waveform at a pixel.

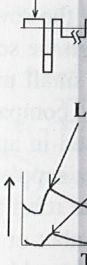

Figure 11.

a maximum selection ratio when the ratio of the amplitude of the pulses in the row waveform to amplitude of the column waveform is \sqrt{N} , where N is the number of rows that are multiplexed in a matrix display. The maximum selection ratio is given by eq. (2). The instantaneous voltage across even an OFF pixel is higher than the threshold voltage of the liquid crystal display. However the RMS voltage across the OFF pixels is maintained below threshold voltage.

LCDs are slow devices with response times in the range of a few tens to few hundred milliseconds. Hence the RMS voltage is important in determining the state of the pixel. Period (T) of the addressing waveforms is assumed to be small as compared to the response times of the LCD. However in a large matrix display or in a display with fast response times the period may become comparable to the response time of the LCD. The conventional line by line addressing is no longer suitable to drive such a display since the resulting contrast in the display is poor(low) due to frame response phenomenon explained below.

9. Frame response

Under optimum conditions for multiplexing (when the selection ratio is maximum), row waveforms deliver one half of the energy to the pixel while the other half of energy is delivered through the column waveforms. In a line by line addressing technique the energy from the row waveform is delivered by a single pulse (which is larger than the threshold voltage). This results in turning even the OFF pixels partially ON resulting in poor contrast. Frame response phenomenon [5] is illustrated in figure 11.

One of the techniques proposed for suppressing frame response is active addressing technique, described below.

10. Active addressing

Active addressing uses Walsh functions as row waveforms [6]. As illustrated in figure 12 all the rows are simultaneously selected by row waveforms corresponding to Walsh functions. The column waveform is generated by taking the orthogonal transform of the data to be displayed. Selection ratio is maximum when amplitude of the row waveforms

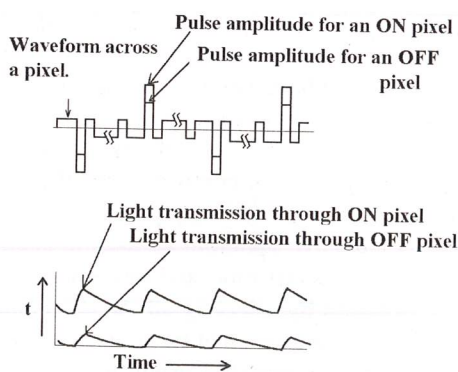

Figure 11. Frame response phenomenon associated with line by line addressing.

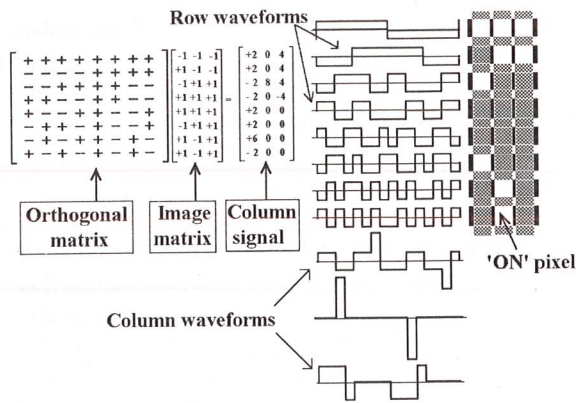

Figure 12. Illustration of active addressing of a passive matrix LCD.

is $(1/\sqrt{N}) V_c$, wherein V_c is the maximum amplitude in the column waveforms and N is the number of rows that are being multiplexed. Frame response is generally suppressed when all the rows are selected. However as one can see in figure 12, when image displayed in a column is same as on one of the orthogonal functions, then the column waveform has a maximum amplitude for one time interval and zero for rest of the time intervals. Then waveform across the pixel will be similar to line by line addressing. This condition is avoided by inverting some of the orthogonal functions and limiting the amplitude of the column voltage. While these practical measures are available for suppressing the frame response, selecting all the rows simultaneously is not preferable for the following reasons:

- Computation necessary for generating the column signal is very high ($N.M$ additions or subtractions for one row select time and approximately $N.N.M$ additions for a frame).
- The number of voltage levels in the column waveforms is $(N + 1)$, hence the hardware complexity of column drivers is high.
- A frame buffer is necessary for computing the column waveforms.
- Access time of such a buffer has to be very short, since the whole image has to be accessed within a row select time (10–100 microseconds).

While active addressing is not the best solution for suppressing frame response, selecting all the rows simultaneously is advantageous in some applications discussed below:

Addressing waveforms may be simplified to have just two voltage levels. The binary addressing technique (BAT) [7] is one such example, where in all the rows are selected simultaneously when the number of rows is small ($N < 9$). Although the selection ratio is lower than that of eq. (2) it is adequate to have good contrast in small matrix displays. Binary addressing technique needs the lowest power supply as compared to all the techniques known so far. Hence it is an attractive option to be used in applications like mobile telephones and calculators. A high contrast ratio and low supply voltage (both independent of matrix size) has been obtained by selecting all the rows simultaneously [13]. Here, the information displayed is restricted such that the number of pixels carrying information in each column is a constant. This approach is useful for addressing displays in oscilloscopes and logic analysers.

11. Multi-line add

A more elegant solution is to select all rows simultaneously rather than one row at a time. This was proposed in 1988 and is treated to be a variation of active addressing. It has been shown that $L = \sqrt{N}$ row waveform is equivalent to L lower than $Lopt$ then the column waveforms. The column waveforms. Thus $L = \sqrt{N}$ is the best choice for electronics. Selection of waveforms is \sqrt{N}/L the number of lines selected and driven to an ON pixel to that of L . However, selecting some of the instantaneous amplitude pulse in the column waveforms in a row lines that are driven to an ON pixel. Figures 13 and 14. Selection of waveforms as shown in

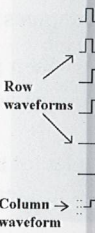

Figure 13. Selection of waveforms as shown in

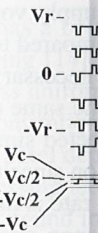

Figure 14. Selection of waveforms as shown in

11. Multi-line addressing

A more elegant solution to suppress frame response is to select and address a few rows simultaneously rather than all the rows [8-12]. This approach is referred to as multi-line selection or multi-line addressing. The improved hybrid addressing technique [8] proposed in 1988 is one such scheme wherein the number of rows simultaneously driven is treated to be a variable (L) and can range from two to any desired value ($L > 1$). It has been shown that $L = \sqrt{N}$ is an optimum condition when the maximum amplitude of the row waveform is equal to the maximum amplitude of the column waveforms. When L is lower than L_{opt} then the row waveforms have a higher amplitude as compared to column waveforms. The column waveforms have a higher amplitude when L is greater than \sqrt{N} . Thus $L = \sqrt{N}$ is the condition for minimum power supply voltage of the drive electronics. Selection ratio is a maximum (given by eq. (2)) when amplitude of the row waveforms is \sqrt{N}/L times the maximum amplitude in the column waveforms, where N is the number of lines that are being multiplexed and L is the number of rows that are selected and driven simultaneously. The selection ratio, the ratio of RMS voltage across an ON pixel to that across an OFF pixel is the same as that of line by line addressing. However, selecting several rows simultaneously has the advantage of reducing amplitudes of the instantaneous voltages across the pixel. In other words, the energy in one large amplitude pulse in the line by line addressing is now distributed in a number of small amplitude pulses in a frame. The actual number of pulses will depend upon the number of lines that are driven simultaneously. Multi-line addressing technique is illustrated in figures 13 and 14. Selecting a few rows simultaneously is adequate to suppress frame response as shown in table 1.

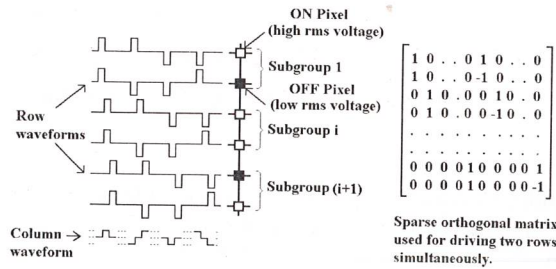

Figure 13. Improved hybrid addressing technique (IHAT), for driving two rows at a time ($L = 2$).

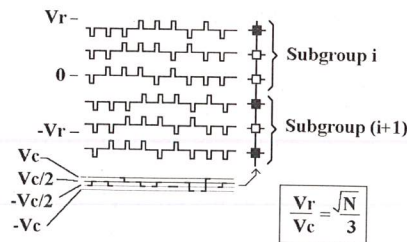

Figure 14. Illustration of row and column waveforms of multi-line addressing (IHAT, $L = 3$).

Table 1. Contrast ratio vs L for different row select times.

L	Row select time	
	20 microseconds	40 microseconds
1	25	7
3	49	29
7	59	50
15	58	48
240	61	52

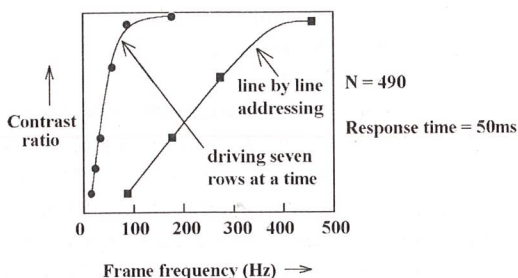

Figure 15. Contrast ratio vs frame frequency comparison between line by line and multi-line addressing.

It is evident from the table that selecting even 3 rows simultaneously results in considerable improvement in contrast ratio of the display ($N = 240$) as compared to line by line addressing ($L = 1$). Contrast ratio when seven rows are selected is almost the same as selecting all the 240 rows. Selecting few rows has the following advantages:

- Number of voltage levels in the column waveform is $(L + 1)$ and as seen above since $L \ll N$, there is a considerable reduction in computation (factor is L/N) necessary for generating the column waveforms.
- Hardware complexity of the column driver is again reduced by a large factor since $L \ll N$.
- Access time of the memory is increased by N/L and the access times are reasonable for practical implementation
- The number of voltage levels in the row waveforms is three as in the case of line by line addressing technique.

Lower amplitude pulses in the multi-line approach reduces the supply voltage of the drive electronics. The frame refresh rate is also relatively lower as compared to that of the line by line addressing. For example, a frame frequency of 400 Hz is necessary to achieve full contrast in a display driven using line by line addressing [10]. The same contrast can be achieved by driving the panel at 75 Hz, when seven rows are selected simultaneously ($L = 7$) as shown in figure 15. This results in lower power consumption since the pixels in the passive matrix LCD are essentially capacitors and as the refresh rate is decreased the power consumption also is reduced. The frame response phenomenon encountered in large matrix displays addressed with line by line addressing is also suppressed when multi-line addressing is used. By the same token the display driven by multi-line



Figure 16. addressing.



Figure 17. (a multi-line)

techniques has a better line addressing [14]. A the brightness uniform driven by conventional background pixel depende hybrid addressing tech of cross-talk found in f display addressed with

One of the limitation the number of lines m

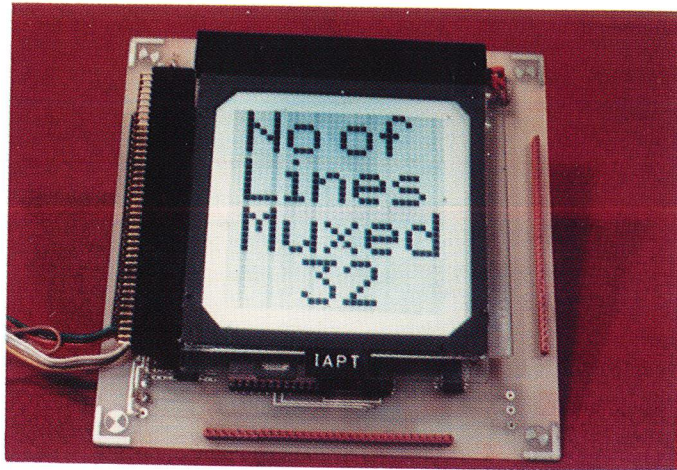

Figure 16. Photograph of a display addressed by the conventional line-by-line addressing.

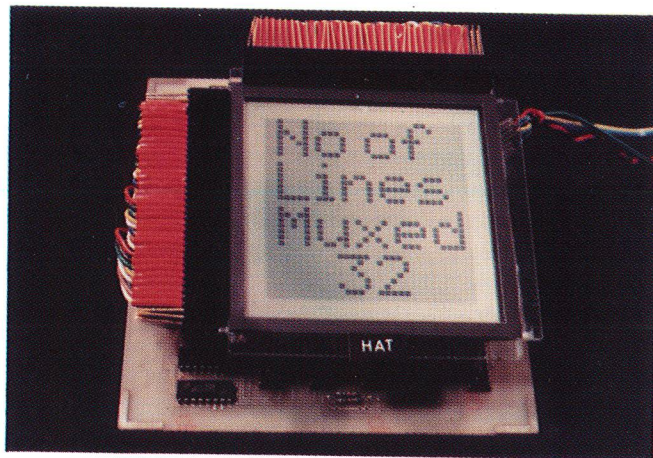

Figure 17. Photograph of a display addressed by hybrid addressing technique (a multi-line-technique) exhibits good brightness uniformity of pixels.

techniques has a better contrast over a wider temperature range as compared to line by line addressing [14]. An additional advantage of driving several rows simultaneously is the brightness uniformity of pixels in the display. A photograph of a 32×32 matrix LCD driven by conventional line by line addressing is shown in figure 16. The gray shade of background pixel depends on the information displayed. The same display addressed with hybrid addressing technique (HAT) [9] has good brightness uniformity. The vertical lines of cross-talk found in figure 16 is absent and all the background pixels look uniform in a display addressed with HAT as shown in figure 17.

One of the limitation of passive matrix LCD is that the selection ratio decreases when the number of lines multiplexed is increased as in the case of large information content

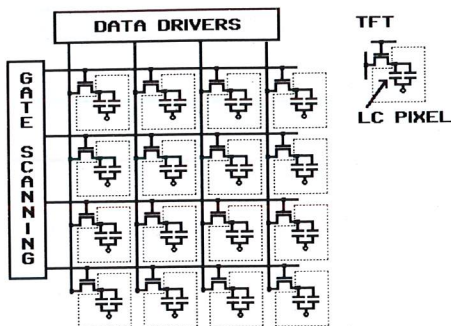

Figure 18. Active matrix LCD.

display. This problem is circumvented by using steep electro-optic characteristics as in the case of super twisted nematic (STN). An alternate approach is to improve the drive technique so that steepness of the electro-optic characteristics is not essential even for large matrix LCDs.

12. Active matrix LCD's

Active matrix addressing and plasma addressing are the other two approaches used in practice today. In the active matrix LCDs a non-linear element like a diode or a transistor is incorporated with each pixel. A schematic of active matrix LCD is shown in figure 18. These non-linear devices act as switches so that each pixel in the liquid crystal panel is a capacitor which is charged to the required voltage. This is very similar to the sample and hold circuit. A line by line approach is used for scanning the matrix LCD. Since the charge is held across the pixel during the full frame period, the selection ratio is infinite and the contrast is good. Twisted nematic effect is mostly used in these active matrix LCDs and the gradual change in transmission comes handy to generate large number of gray shades.

Performance of active matrix LCDs has improved during the past decade. The viewing angle characteristics have been improved using multi-domains in each pixel, in-plane switching etc. Active matrix LCDs are starting to replace the CRT in the traditional areas like desktop computer monitors. While the performance of the active matrix LCDs are comparable if not better than CRTs, the cost of the LCD is very much higher than that of CRT. This is mainly due to fabrication of thin film transistors against each pixel in the display. Row and column drivers are integrated circuits fabricated with conventional silicon technology and are outside the active matrix. The cost of the display drivers is a significant part of the total panel cost. There is an effort to integrate the row and column driver circuits into the active matrix and this needs low temperature poly-silicon technology. The cost of the active matrix is likely to reduce once these integrated panels are commercially available.

13. Plasma addressing

The plasma addressing [15] is an alternative technique wherein the panel structure complexity is in between that of active matrix and passive matrix. A plasma channel is

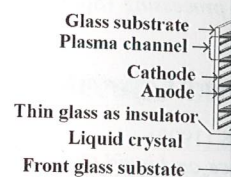

Figure 19. Schematic of plasma-addressed LCD.

provided behind each pixel. The plasma channel is connected to the corresponding plasma channel in figure 19. Principle of operation of the active plasma addressing is applied in parallel to each pixel. The pixels are capacitively coupled to the plasma channel separating the plasma channel. The pixels are charged to the required voltage. The plasma channel has a high impedance and acts as a hold circuit for a full frame period. Thus in a plasma-addressed LCD, in the case of active matrix addressing (each row and column) the same function is performed. So instead of $N.M$ transistors, the plasma addressing technique [15] for the fabrication of the plasma-addressed LCD panels may be preferred.

14. Conclusion

All the three approaches are used in practice today. The plasma addressing approach is used in small displays like calculators, mobile phones etc. The active matrix addressing seems to be the most promising approach. The power consumption and cost are more popular in desktop computers and a small display is preferred for large displays.

References

- [1] T N Ruckmongathan, submitted to Department of Science, Bangalore.

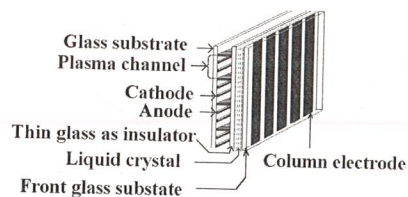

Figure 19. Schematic of a plasma addressed LCD.

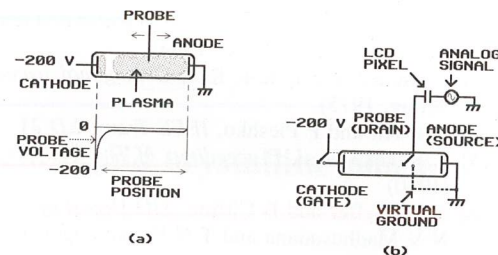

Figure 20. Principle of plasma addressing.

provided behind each row to be multiplexed. Each row is selected by striking a plasma in the corresponding plasma channel. Schematic of a plasma addressed panel is shown in figure 19. Principle of plasma addressing is illustrated in figure 20. The low impedance of the active plasma acts like a virtual ground to the pixels in that row. Data voltages are applied in parallel to the columns. The pixels are charged to the data voltage. The pixels are capacitively coupled to the plasma channel. The glass plate with electrode patterns separating the plasma channel and the liquid crystal is thin (50 micrometers). Once the pixels are charged to the required voltages the plasma is cut-off and the plasma channel has a high impedance. Voltages across the pixels are held as in the case of sample and hold circuit for a full frame period till the row is selected to be refreshed in the successive frames. Thus in a plasma addressed LCD infinite selection ratio is achieved just as in the case of active matrix LCDs. While active matrix LCD has M transistors (one per column) the same function is achieved with just a single plasma channel (one per row). So instead of $N.M$ transistors in an active matrix there are N plasma channels. The fabrication of the plasma addressed LCD has been simplified by using screen printing techniques [16]. This approach has the advantage that very large (40" diagonal) LCD panels may be fabricated.

14. Conclusion

All the three approaches to driving matrix LCDs are used today. The passive matrix approach is used in small and medium sized displays (size up to 4 or 5" diagonal) found in calculators, mobile telephones, palm top computers, digital organizers etc. The multi-line addressing seems to be favoured in applications where in low voltage operation, low power consumption and wide operating temperature are desired. The active matrix LCDs are more popular in medium size displays (8.5" to 15" diagonal) mostly in portable computers and a small segment of desktop computers. The plasma addressed LCDs are poised for large displays (greater than 20" diagonal) mainly in television receivers.

References

- [1] T N Ruckmongathan, *Some new addressing techniques for RMS responding LCD's*, a thesis submitted to Department of Electrical Communication Engineering, Indian Institute of Science, Bangalore, India (1988)

- [2] K G Beauchamp, *Applications of walsh and related functions with an introduction to sequency theory* (Academic Press, 1984)
- [3] N Ahmed and L K R Rao, *Orthogonal transforms for digital signal processing* (Springer-Verlag, 1975)
- [4] P M Alt and P Pleshko, *IEEE Trans. ED* **21**, 145 (1974)
- [5] Y Kaneko *et al*, *Proceedings of The Tenth International Display Research Conference*, 100 (1990)
- [6] T J Scheffer and B Clifton, *SID Digest of Technical Papers* **XXII**, 228 (1992)
- [7] N V Madhusudana and T N Ruckmongathan, *Proc. of Inter. Conference on Liquid Crystals*, 499 (1979)
- [8] T N Ruckmongathan, International Display Research Conference (IDRC), 80 (1988)
- [9] T N Ruckmongathan and N V Madhusudana, *Proceedings of the SID*, **24/3**, 259 (1983)
- [10] S Ihara, Y Sugimoto, Y Nakagava, T Kuwata, H Koh, H Hasebe and T N Ruckmongathan, *SID 92 Digest*, 232 (1992)
- [11] T N Ruckmongathan, *Japan Display'92*, 77 (1992)
- [12] T N Ruckmongathan, Conference on Emerging Optoelectronics Technologies (CEOT-94), 302 (1994)
- [13] T N Ruckmongathan, *SID 96 Digest*, 562 (1996)
- [14] H Muraji, T Matsumoto, T N Ruckmongathan, K Sigeuo and K Ohara, SAE technical papers, 51 (1993)
- [15] T Buzak, *SID 90 Digest*, 420 (1990)
- [16] Shoichi Tanamachi, *Display Devices '97*, 29 (1997)

Molecular str

B K SADASHIVA
Raman Research Instit

Abstract. We describe chiral mesophases. We report a twist grain boundary C^* composed of banana-shaped molecules by polarized light optical

Keywords. Chiral; ac

PACS Nos 61.30.-V;

1. Introduction

As is well known, chiral mesophases covered is chiral in nature. In the past, they were not examined. This was first examined by Meyer *et al* [1] gave a chiral phase, then, a large number of chiral mesophases [2]. Later, as a result of the discovery of ferroelectric phase was discovered serendipitously while studying the antiferroelectric phase by assessing the molecular structure.

The discovery of nematic mesophases in 1996 by chiral molecules from achiral systems. In this paper, we report a twist grain boundary C^* (UTGB $_C$).

In this paper, we report a twist grain boundary C^* (UTGB $_C$). This concerns the twist grain boundary exhibiting the undulating chiral mesophase exhibited by

2. Experimental

The intermediate and final stages of the gel using chloroform crystallization from suitable layer chromatography