

(54) **CARBONIC ANHYDRASE BIOREACTOR AND PROCESS FOR CO₂ CONTAINING GAS EFFLUENT TREATMENT**

(75) Inventors: **Carmen Parent**, Québec (CA); **Frédéric Dutil**, Québec (CA)

(73) Assignee: **CO2 Solutions Inc.**, Quebec (CA)

(*) Notice: Subject to any disclaimer, the term of this patent is extended or adjusted under 35 U.S.C. 154(b) by 0 days.

This patent is subject to a terminal disclaimer.

(21) Appl. No.: **12/802,353**

(22) Filed: **Jun. 4, 2010**

(65) **Prior Publication Data**

US 2010/0248323 A1 Sep. 30, 2010

Related U.S. Application Data

(60) Continuation of application No. 12/462,612, filed on Aug. 5, 2009, which is a continuation of application No. 11/646,758, filed on Dec. 27, 2006, now Pat. No. 7,579,185, which is a division of application No. 10/195,848, filed on Jul. 12, 2002, now Pat. No. 7,176,017.

(30) **Foreign Application Priority Data**

Jul. 13, 2001 (CA) 2353307

(51) **Int. Cl.**

- C12M 1/12** (2006.01)
- C12M 1/14** (2006.01)
- C12M 3/04** (2006.01)
- C12M 1/36** (2006.01)
- C12M 1/38** (2006.01)
- C12M 1/00** (2006.01)
- C12M 3/00** (2006.01)

(52) **U.S. Cl.** **435/299.1**; 435/297.1; 435/286.6; 435/289.1; 435/296.1

(58) **Field of Classification Search** 435/283.1–309.4
See application file for complete search history.

(56) **References Cited**

U.S. PATENT DOCUMENTS

534,498 A 2/1895 Descamps
(Continued)

FOREIGN PATENT DOCUMENTS

AU 7753398 12/1998
(Continued)

OTHER PUBLICATIONS

John P. Allen PhD, "An Enzymic Concept for CO₂ Control in Closed Environmental Control Systems," Technical Report AFFDL-TR-65-48, Aug. 1965, 56 pages, Air Force Flight Dynamics Laboratory, Research Technology Division, Air Force Systems Command, Wright-Patterson Air Force Base, Ohio, USA (56 pages).

(Continued)

Primary Examiner — Nathan Bowers

Assistant Examiner — Lydia Edwards

(74) *Attorney, Agent, or Firm* — Ware, Fressola, Van Der Sluys & Adolphson LLP

(57) **ABSTRACT**

A triphasic bioreactor for physico-chemically treating a gas is disclosed. The triphasic bioreactor comprises a reaction chamber with a liquid and biocatalysts in suspension in the liquid, for catalyzing a reaction between the gas and the liquid to obtain a treated gas and a solution containing a reaction product. A gas bubbling means is provided in the reaction chamber for bubbling the gas to be treated into the liquid thereby dissolving the gas into the liquid and increasing a pressure inside the reaction chamber. The bioreactor further comprises a liquid inlet in fluid communication with the reaction chamber for receiving the liquid and filling the reaction chamber, a liquid outlet in fluid communication with the reaction chamber for releasing the solution and a gas outlet in fluid communication with the reaction chamber to release the treated gas. The bioreactor further comprises a retention device to retain the biocatalysts in the reaction chamber. The invention also concerns a process using the triphasic bioreactor. The triphasic bioreactor may advantageously be used for removing carbonic dioxide from a CO₂-containing gas.

43 Claims, 4 Drawing Sheets

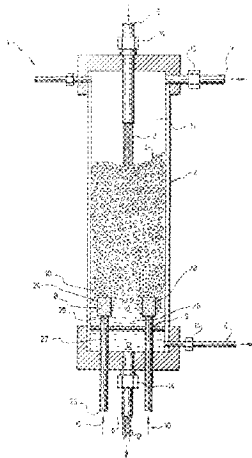

U.S. PATENT DOCUMENTS			FOREIGN PATENT DOCUMENTS		
1,450,770	A	4/1923 Frick et al.	5,547,586	A	8/1996 Halperin et al.
2,956,070	A	10/1960 Jennings et al.	5,593,886	A	1/1997 Gaddy
3,242,055	A	3/1966 De Lucia	5,603,908	A	2/1997 Yoshida et al.
3,365,063	A	1/1968 Cobb	5,609,838	A	3/1997 Neuman et al.
3,528,912	A	9/1970 Boyle et al.	5,614,378	A	3/1997 Yang et al.
3,610,418	A	10/1971 Calderwood	5,618,430	A	4/1997 Fuchs
3,659,400	A	5/1972 Kester	5,618,506	A	4/1997 Suzuki et al.
3,700,592	A	10/1972 De Pree	5,624,812	A	4/1997 Hattori et al.
3,853,712	A	12/1974 House et al.	5,665,319	A	9/1997 Hiram et al.
3,878,043	A	4/1975 Matta et al.	5,667,561	A	9/1997 Suzuki et al.
3,896,212	A	7/1975 Eickmeyer et al.	5,674,463	A	10/1997 Dao et al.
3,910,780	A	10/1975 Henley et al.	5,683,356	A	11/1997 Halperin et al.
3,925,534	A	12/1975 Singleton	5,690,099	A	11/1997 Abramov et al.
4,032,616	A	6/1977 Artur et al.	5,739,004	A	4/1998 Woodson
4,033,822	A	7/1977 Gregor	5,744,078	A	4/1998 Soroushian et al.
4,046,529	A	9/1977 Fletcher et al.	5,746,985	A	5/1998 Takahashi
4,047,894	A	9/1977 Kuhl	5,759,712	A	6/1998 Hockaday
4,048,018	A	9/1977 Coughlin et al.	5,766,339	A	6/1998 Babu et al.
4,067,809	A	1/1978 Kato	5,772,887	A	6/1998 Noah et al.
4,072,615	A	2/1978 McConnell	5,785,739	A	7/1998 Baker
4,073,686	A	2/1978 Adams	5,795,750	A	8/1998 Kruse et al.
4,112,052	A	9/1978 Sartori et al.	5,807,722	A	9/1998 Gaddy
4,137,298	A	1/1979 Zielke et al.	5,830,423	A	11/1998 Trocciola et al.
4,162,298	A	7/1979 Holladay et al.	5,858,746	A	1/1999 Hubbell et al.
4,230,803	A	10/1980 Weidenbach et al.	5,861,303	A	1/1999 Barshter et al.
4,234,419	A	11/1980 Coillet	5,869,323	A	2/1999 Horn
4,266,026	A	5/1981 Breslau	5,888,256	A	3/1999 Morrison
4,292,199	A	9/1981 Rohrbach et al.	5,902,747	A	5/1999 Nemser et al.
4,307,195	A	12/1981 Karasawa et al.	5,938,819	A	8/1999 Seery
4,307,298	A	12/1981 El Hamamsy et al.	5,945,002	A	8/1999 Leukes et al.
4,336,233	A	6/1982 Appl et al.	5,972,684	A	10/1999 Bandman et al.
4,427,416	A	1/1984 Bonaventura et al.	5,997,594	A	12/1999 Edlund et al.
4,434,142	A *	2/1984 Huckabay 423/111	5,998,637	A	12/1999 Furu et al.
4,434,144	A	2/1984 Giammarco et al.	6,010,900	A	1/2000 Cherry
4,452,676	A	6/1984 Birbara et al.	6,036,931	A	3/2000 Yoshida et al.
4,521,387	A	6/1985 Broecker et al.	6,051,161	A	4/2000 Suzuki et al.
4,537,839	A	8/1985 Cameron	6,051,411	A	4/2000 Turtakovsky et al.
4,563,202	A	1/1986 Yao et al.	6,071,484	A	6/2000 Dingman et al.
4,602,987	A	7/1986 Bonaventura et al.	6,081,736	A	6/2000 Colvin et al.
4,628,037	A *	12/1986 Chagnon et al. 436/526	6,082,133	A	7/2000 Barclay et al.
4,681,605	A	7/1987 Gollan	6,110,370	A	8/2000 Van Hille et al.
4,681,612	A	7/1987 O'Brien et al.	6,117,404	A	9/2000 Mimura et al.
4,696,803	A	9/1987 Nieh et al.	6,128,919	A	10/2000 Daus et al.
4,710,362	A	12/1987 Nieh	6,136,577	A	10/2000 Gaddy
4,743,545	A	5/1988 Torobin	6,143,556	A	11/2000 Trachtenberg
4,758,417	A	7/1988 van Lookeren-Campagne	6,170,264	B1	1/2001 Viteri et al.
4,761,209	A *	8/1988 Bonaventura et al. 205/633	6,174,720	B1	1/2001 Oxley et al.
4,770,676	A	9/1988 Sircar et al.	6,187,277	B1	2/2001 Kirschner
4,814,104	A	3/1989 Kubek	6,187,465	B1	2/2001 Galloway
4,931,388	A *	6/1990 Katinger 435/41	6,203,599	B1	3/2001 Schubert et al.
4,978,619	A	12/1990 Kajiwara et al.	6,210,567	B1	4/2001 Takada
5,000,768	A	3/1991 Hwang	6,221,117	B1	4/2001 Edlund et al.
5,005,787	A	4/1991 Cullingford	6,240,859	B1	6/2001 Jones, Jr.
5,057,421	A	10/1991 Hofmann et al.	6,245,304	B1	6/2001 Jansen et al.
5,061,455	A	10/1991 Brose et al.	6,255,047	B1	7/2001 Toblesky et al.
5,104,803	A	4/1992 Delente	6,257,335	B1	7/2001 Nguyen et al.
5,112,740	A	5/1992 Nealon et al.	6,258,335	B1	7/2001 Bhattacharya
5,116,506	A	5/1992 Williamson et al.	6,298,859	B1	10/2001 Kierulff et al.
5,130,237	A	7/1992 Thomas et al.	6,319,868	B1	11/2001 Gani et al.
5,137,828	A	8/1992 Robinson et al.	6,524,843	B1	2/2003 Blais et al.
5,141,823	A	8/1992 Wright et al.	7,078,225	B2	7/2006 Semba et al.
5,143,847	A	9/1992 Kawase et al.	7,176,017	B2 *	2/2007 Parent et al. 435/297.1
5,169,051	A	12/1992 Noe	7,579,185	B2 *	8/2009 Parent et al. 435/299.1
5,182,201	A	1/1993 Tsuda	2003/0017449	A1 *	1/2003 Adams et al. 435/5
5,226,506	A	7/1993 Link			
5,232,676	A	8/1993 Wolff et al.	CA	950364	7/1974
5,242,827	A	9/1993 Chaumont et al.	CA	1078300	5/1980
5,246,619	A	9/1993 Niswander	CA	1143910	4/1983
5,246,855	A	9/1993 Katinger et al.	CA	1188630	6/1985
5,248,567	A	9/1993 Amemiya et al.	CA	1190470	7/1985
5,250,305	A	10/1993 Hamada	CA	1194399	10/1985
5,293,751	A	3/1994 Asai	CA	1214316	11/1986
5,304,356	A	4/1994 Iijima et al.	CA	2002227	6/1990
5,364,611	A	11/1994 Iijima et al.	CA	2030391	5/1991
5,389,120	A	2/1995 Sewell et al.	CA	1291787	11/1991
5,455,013	A	10/1995 Shibata et al.	CA	1294758	1/1992
5,486,475	A	1/1996 Kramer et al.	CA	2029101	5/1992
5,514,378	A	5/1996 Mikos et al.	CA	2222030	12/1996

CA	2232707	3/1997	JP	9168775	6/1997
CA	2160311	4/1997	JP	52138477	11/1997
CA	2238323	5/1997	JP	10130045	5/1998
CA	2200130	9/1997	JP	10314758	12/1998
CA	2259492	1/1998	JP	110501180	1/1999
CA	2291785	12/1998	JP	11050069	2/1999
CA	2297785	12/1998	JP	11235999	8/1999
CA	2294531	2/1999	JP	2000072981	3/2000
CA	2320216	8/1999	JP	2000119049	4/2000
CA	2322871	9/1999	JP	2000202239	7/2000
CA	2352969	5/2000	JP	2000-236870	9/2000
CA	2255287	6/2000	JP	2000239670	9/2000
CA	2361809	8/2000	JP	2000-287679	10/2000
CA	2268641	1/2001	JP	2000287679	10/2000
CA	2326024	6/2001	JP	2000300983	10/2000
CN	1101626	4/1995	JP	2001039751	2/2001
CN	1227255	9/1999	JP	2001070726	3/2001
DE	3218232	2/1984	TW	432741	5/2001
DE	3729695	3/1988	WO	9200380	1/1992
DE	3937892	5/1991	WO	9524959	9/1995
DE	4032557	4/1992	WO	9640414	12/1996
DE	4419766	12/1995	WO	97/19196	5/1997
DE	19840691	3/2000	WO	98/00558	1/1998
EP	180670	5/1986	WO	98/55210	12/1998
EP	207277	1/1987	WO	9966260	12/1998
EP	315468	5/1989	WO	98/55210	* 12/1998
EP	0328758	8/1989	WO	0003126	1/2000
EP	511719	7/1990	WO	0010691	3/2000
EP	511719	11/1992	WO	0104045	1/2001
EP	558019	9/1993	WO	0117896	3/2001
EP	649385	4/1995	WO	0123302	4/2001
EP	677883	10/1995	WO	0125140	4/2001
EP	700107	3/1996			
EP	879631	11/1998			
EP	948390	10/1999			
EP	991462	4/2000			
FR	2669918	6/1992			
FR	2758740	7/1998			
GB	103290	12/1917			
GB	384060	12/1932			
GB	587101	4/1947			
GB	848528	9/1960			
GB	1102943	2/1968			
GB	1120483	7/1968			
GB	1306853	2/1973			
GB	2076849	12/1981			
IT	1260517	12/1993			
JP	54132291	10/1979			
JP	57130527	8/1982			
JP	58208117	12/1983			
JP	60014908	1/1985			
JP	63-129987	6/1988			
JP	2000699	1/1990			
JP	2109986	4/1990			
JP	03-216180	9/1991			
JP	4075537	3/1992			
JP	4084883	3/1992			
JP	04-190782	7/1992			
JP	5049881	3/1993			
JP	6011599	1/1994			
JP	6198122	7/1994			
JP	6263665	9/1994			
JP	7068164	3/1995			
JP	8116965	5/1996			
JP	8252430	10/1996			
JP	9057289	3/1997			
JP	9110485	4/1997			
JP	9132494	5/1997			

OTHER PUBLICATIONS

John P. Allen, "Investigation of the Enhancement of Carbon Dioxide Absorption by Amines With the Enzyme Carbonic Anhydrase," Technical Report AFFDL-TR-66-23, May 1966, 42 pages, Air Force Flight Dynamics Laboratory, Research Technology Division, Air Force Systems Command, Wright-Patterson Air Force Base, Ohio, USA (42 pages).

George Graf, Youngstown University, "Regenerative Control of CO₂ in Air by Carbonic Anhydrase," Technical Report AFFDL-TR-66-62, May 1966, 182 pages, Air Force Flight Dynamics Laboratory, Research Technology Division, Air Force Systems Command, Wright-Patterson Air Force Base, Ohio, USA (182 pages).

Douglas N. Dean et al., "Batch Absorption of CO₂ by Free and Microencapsulated Carbonic Anhydrase," *Ind. Eng. Chem., Fundam.*, vol. 16, No. 4, 1977, pp. 452-458 (7 pages).

Terrence L. Donaldson et al., "Kinetic Constants Determined from Membrane Transport Measurements: Carbonic Anhydrase Activity at High Concentrations," *Proc. Nat. Acad. Sci. USA*, vol. 71, No. 12, pp. 4995-4999, Dec. 1974 (5 pages).

"Promotion of Oxygen Transfer in Three-Phase Fluidized-Bed Bioreactors by Floating Bubble Breakers" by Y. Kang et al.; *Biotechnology & Bioengineering*, vol. 37, No. 6, Mar. 15, 1991, pp. 580-586.

Deshusses M.A. et al "Transient-State Behavior of a Biofilter Removing Mixtures of Vapors of MEK and MIBK from Air", 1995, *Biotechnology and Bioengineering*, vol. 49, pp. 587-598.

"Gas Absorption Mechanism in Catalytic Slurry Reactors" by E. Alper et al; *Chemical Engineering Science* vol. 35, pp. 217-222, Pergamon Press Ltd., 1980. Printed in Great Britain.

* cited by examiner

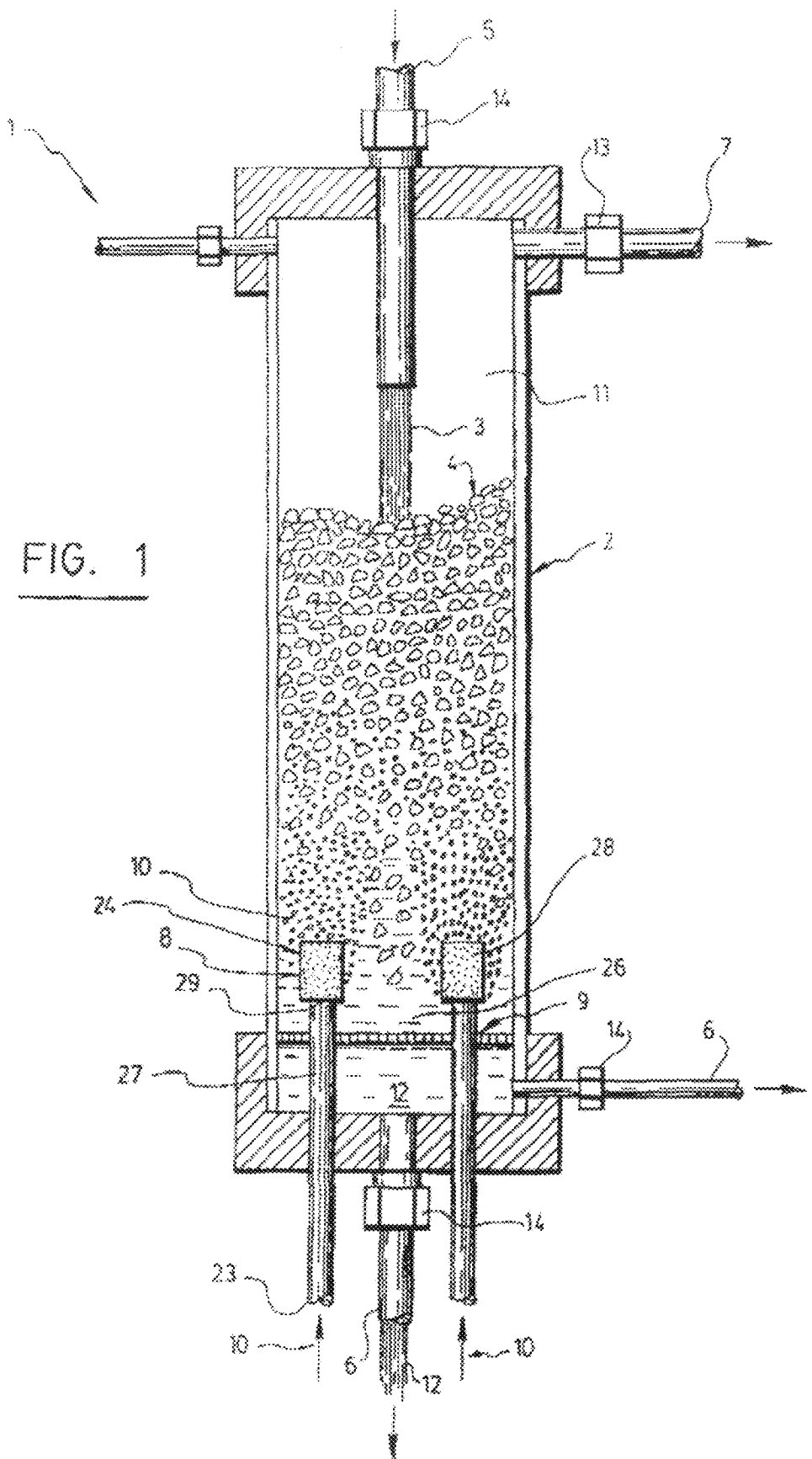

FIG. 1

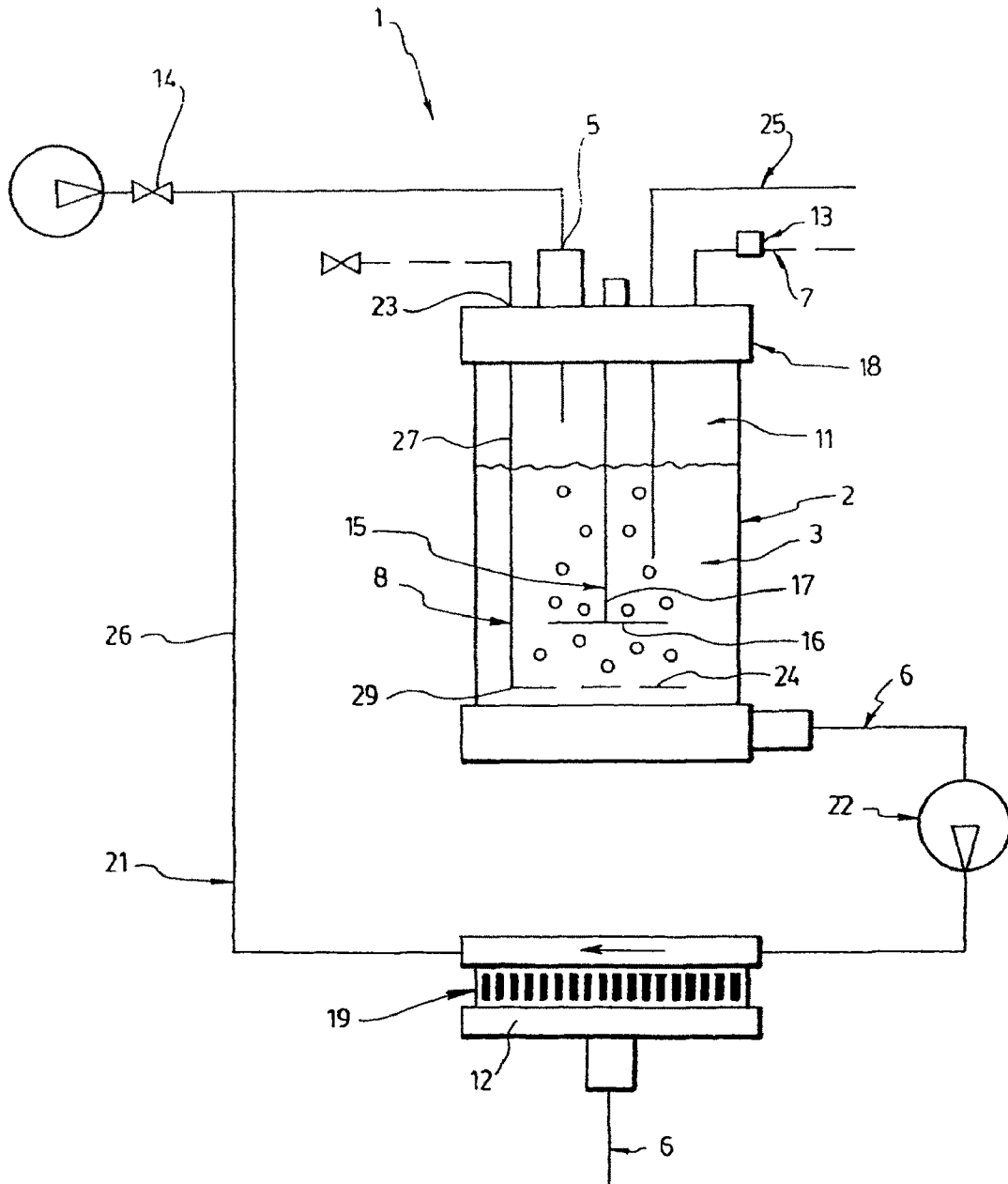

FIG. 2

Explore Litigation Insights

Docket Alarm provides insights to develop a more informed litigation strategy and the peace of mind of knowing you're on top of things.

Real-Time Litigation Alerts



Keep your litigation team up-to-date with **real-time alerts** and advanced team management tools built for the enterprise, all while greatly reducing PACER spend.

Our comprehensive service means we can handle Federal, State, and Administrative courts across the country.

Advanced Docket Research



With over 230 million records, Docket Alarm's cloud-native docket research platform finds what other services can't. Coverage includes Federal, State, plus PTAB, TTAB, ITC and NLRB decisions, all in one place.

Identify arguments that have been successful in the past with full text, pinpoint searching. Link to case law cited within any court document via Fastcase.

Analytics At Your Fingertips



Learn what happened the last time a particular judge, opposing counsel or company faced cases similar to yours.

Advanced out-of-the-box PTAB and TTAB analytics are always at your fingertips.

API

Docket Alarm offers a powerful API (application programming interface) to developers that want to integrate case filings into their apps.

LAW FIRMS

Build custom dashboards for your attorneys and clients with live data direct from the court.

Automate many repetitive legal tasks like conflict checks, document management, and marketing.

FINANCIAL INSTITUTIONS

Litigation and bankruptcy checks for companies and debtors.

E-DISCOVERY AND LEGAL VENDORS

Sync your system to PACER to automate legal marketing.