



(19) **United States**

(12) **Patent Application Publication** (10) **Pub. No.: US 2003/0156092 A1**  
Suzuki et al. (43) **Pub. Date: Aug. 21, 2003**

(54) **DISPLAY CONTROL DEVICE OF LIQUID CRYSTAL PANEL AND LIQUID CRYSTAL DISPLAY DEVICE**

**Publication Classification**

(75) Inventors: Toshiaki Suzuki, Kawasaki (JP);  
Koichi Katagawa, Kawasaki (JP);  
Koshu Yonemura, Kawasaki (JP);  
Toshihiro Kojima, Kawasaki (JP);  
Takashi Yuda, Kawasaki (JP)

(51) **Int. Cl.<sup>7</sup>** ..... **G09G 3/36**  
(52) **U.S. Cl.** ..... **345/98**

(57) **ABSTRACT**

Correspondence Address:  
**Patrick G. Burns, Esq.**  
**GREER, BURNS & CRAIN, LTD.**  
**Suite 2500**  
**300 South Wacker Dr.**  
**Chicago, IL 60606 (US)**

An operational unit determines, for subfield(s) other than a last subfield of a plurality of subfields constituting a single frame period, based on a difference determined by a data comparison unit, exceeded display data for setting the transmittance of each pixel to a value exceeding a target transmittance corresponding to image data supplied anew. The operational unit also determines, for the last subfield of the single frame period, based on the difference determined by the data comparison unit, target display data for setting the transmittance of each pixel to the target transmittance. An overshoot operation or operations are performed within the single frame period, and each pixel is set to the transmittance corresponding to the image data. This makes it possible to avoid trails occurring in moving image display and enhance the appearance of moving image display with no increase in frame rate.

(73) Assignee: **FUJITSU DISPLAY TECHNOLOGIES CORPORATION**

(21) Appl. No.: **10/260,364**

(22) Filed: **Sep. 30, 2002**

(30) **Foreign Application Priority Data**

Feb. 20, 2002 (JP) ..... 2002-043526

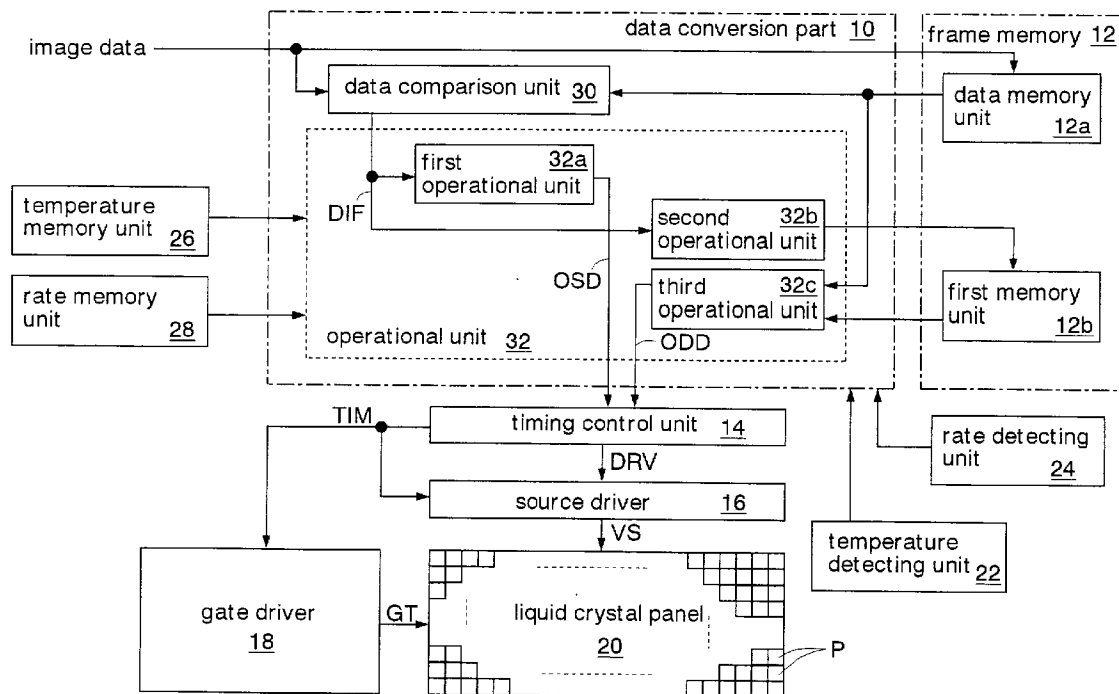

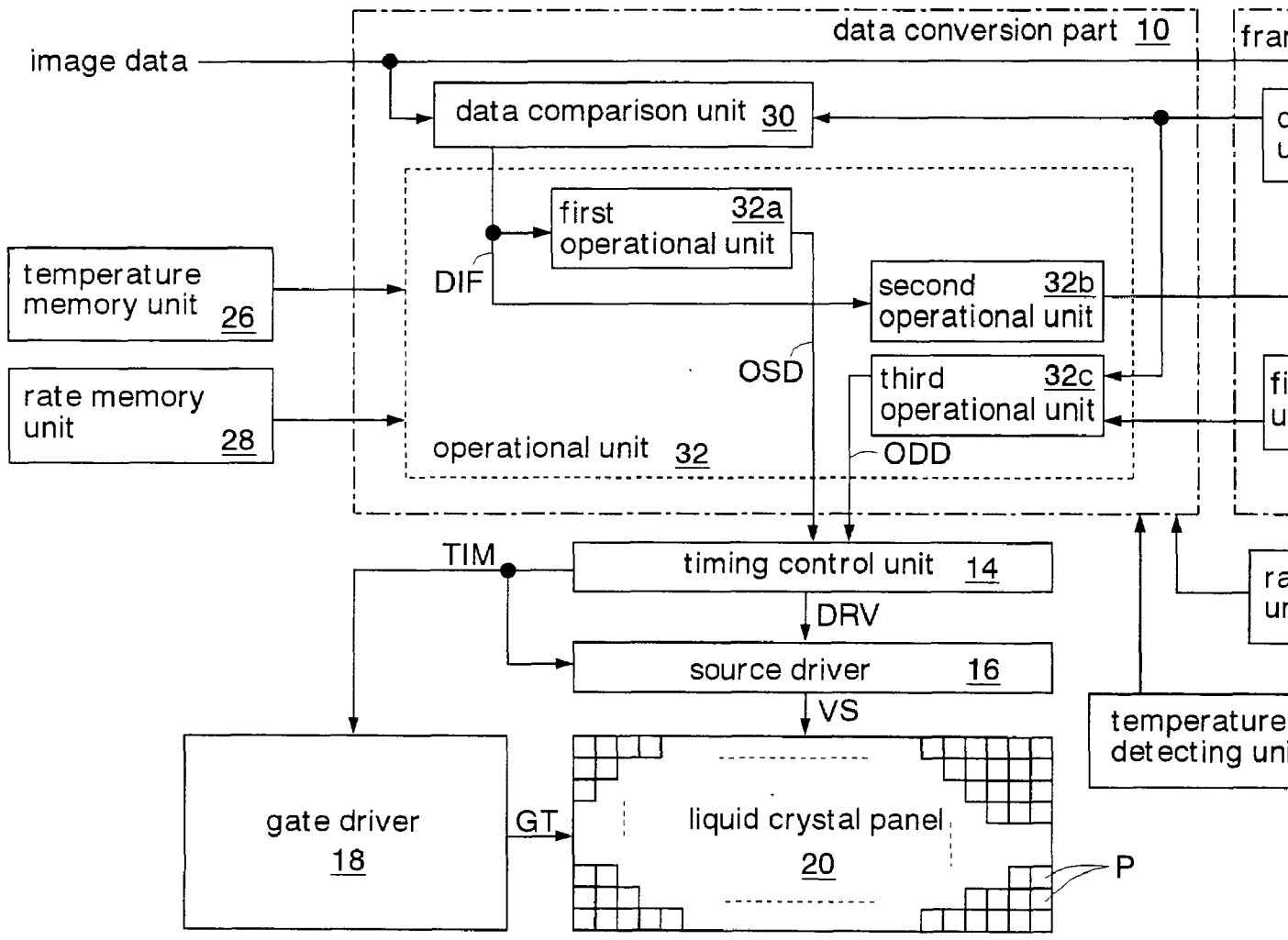

Fig. 1

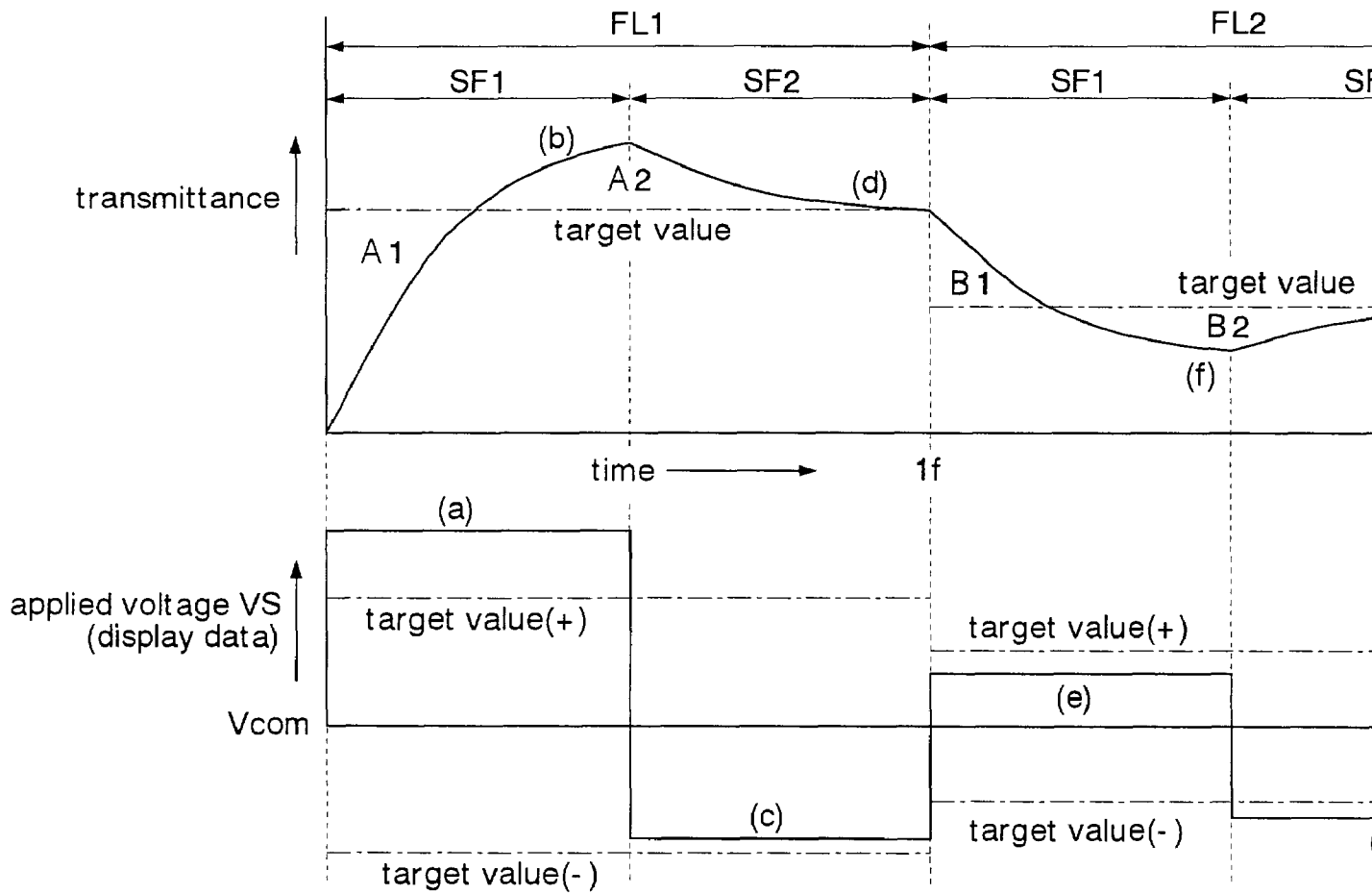

Fig. 2

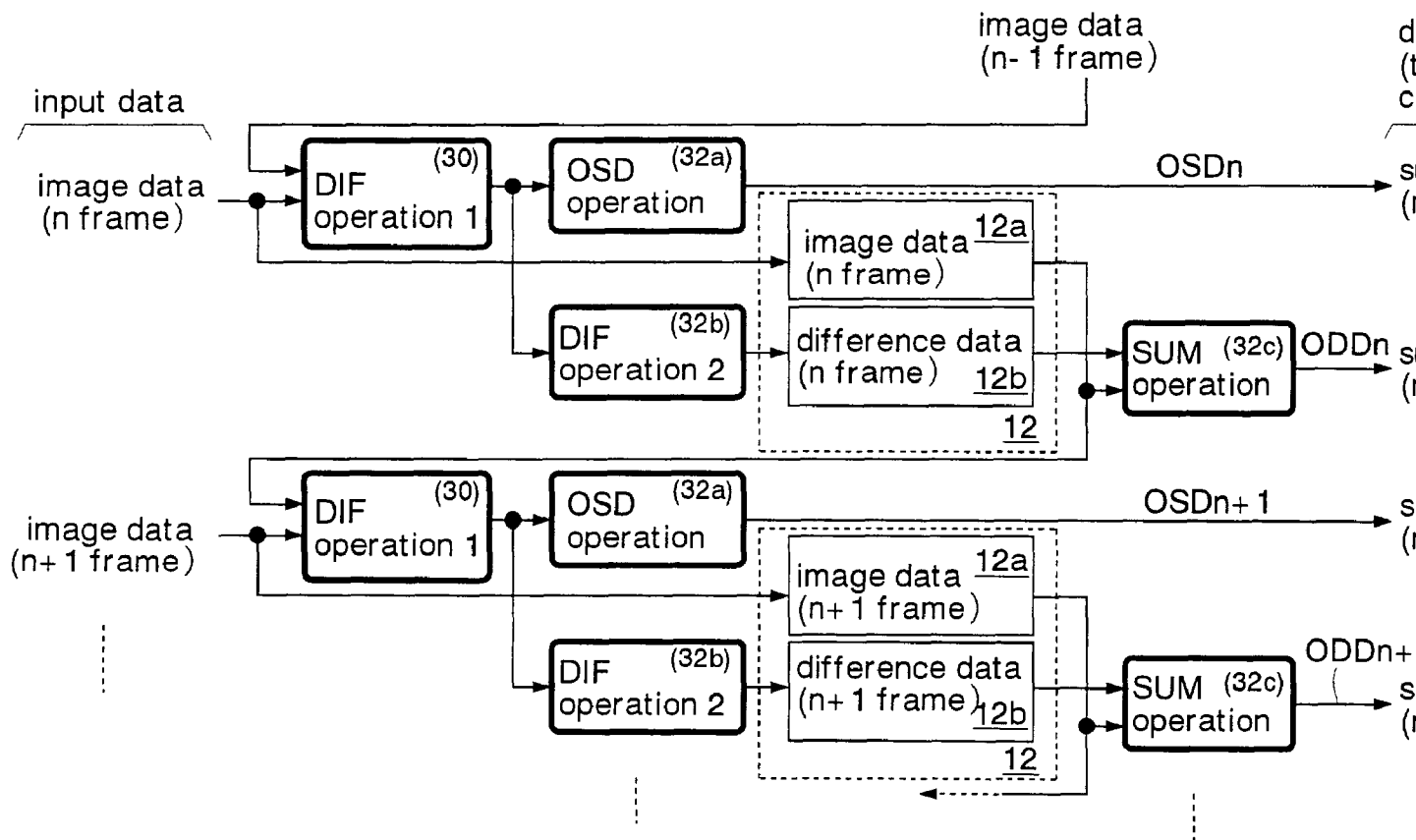

Fig. 3

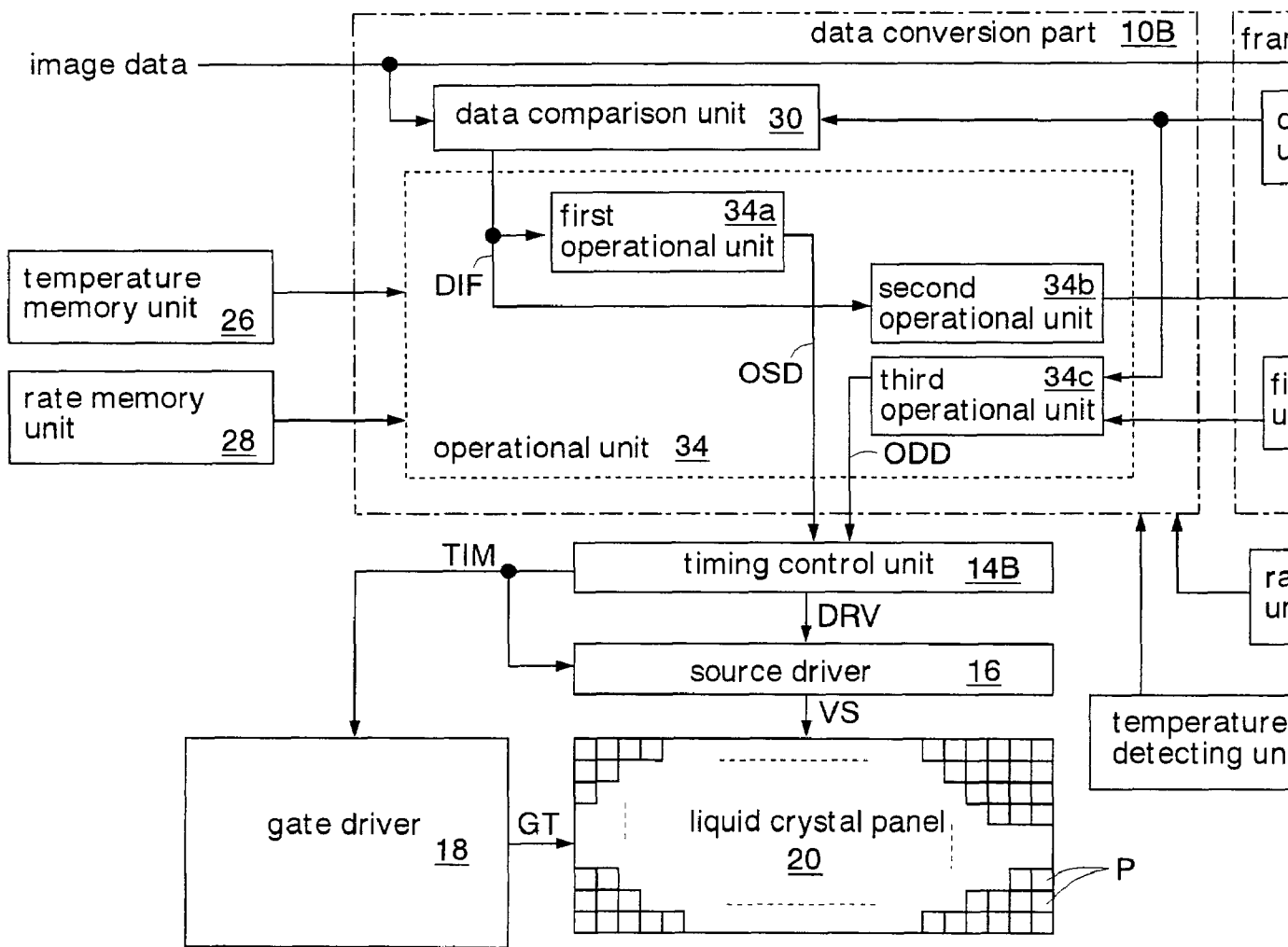

Fig. 4

# Explore Litigation Insights

Docket Alarm provides insights to develop a more informed litigation strategy and the peace of mind of knowing you're on top of things.

## Real-Time Litigation Alerts



Keep your litigation team up-to-date with **real-time alerts** and advanced team management tools built for the enterprise, all while greatly reducing PACER spend.

Our comprehensive service means we can handle Federal, State, and Administrative courts across the country.

## Advanced Docket Research



With over 230 million records, Docket Alarm's cloud-native docket research platform finds what other services can't. Coverage includes Federal, State, plus PTAB, TTAB, ITC and NLRB decisions, all in one place.

Identify arguments that have been successful in the past with full text, pinpoint searching. Link to case law cited within any court document via Fastcase.

## Analytics At Your Fingertips



Learn what happened the last time a particular judge, opposing counsel or company faced cases similar to yours.

Advanced out-of-the-box PTAB and TTAB analytics are always at your fingertips.

## API

Docket Alarm offers a powerful API (application programming interface) to developers that want to integrate case filings into their apps.

## LAW FIRMS

Build custom dashboards for your attorneys and clients with live data direct from the court.

Automate many repetitive legal tasks like conflict checks, document management, and marketing.

## FINANCIAL INSTITUTIONS

Litigation and bankruptcy checks for companies and debtors.

## E-DISCOVERY AND LEGAL VENDORS

Sync your system to PACER to automate legal marketing.