

(12)

(43) Date of publication:  
03.06.1998 Bulletin 1998/23

(51) Int. Cl.<sup>6</sup>: **A24F 47/00**  
// A61M15/06

(21) Application number: **97925295.4**

(86) International application number:  
**PCT/JP97/01953**

(22) Date of filing: **09.06.1997**

(87) International publication number:  
**WO 97/48293 (24.12.1997 Gazette 1997/55)**

(84) Designated Contracting States:  
**DE FR GB**

(30) Priority: **17.06.1996 JP 155636/96**

(71) Applicant: **Japan Tobacco Inc.**  
**Minato-Ku Tokyo 105 (JP)**

(72) Inventors:  
• **SUSA, Masayuki-Japan Tobacco Inc.**  
**Tokyo 130 (JP)**  
• **TAKEUCHI, Manabu-Japan Tobacco Inc.**  
**Tokyo 130 (JP)**

• **KOBAYASHI, T.-Japan Tobacco Inc. Engin. R+D Center**  
**Kanagawa-ken 254 (JP)**  
• **SASAKI, Hiroshi-Japan Tobacco Inc. Eng. R+D Center D**  
**Kanagawa-ken 254 n (JP)**  
• **BANDAI, Takeshi-Japan Tobacco Inc. Eng. R+D Center D**  
**Kanagawa-ken 254 n (JP)**

(74) Representative:  
**Ruffles, Graham Keith**  
**MARKS & CLERK,**  
**57-60 Lincoln's Inn Fields**  
**London WC2A 3LS (GB)**

**(54) FLAVOR PRODUCING ARTICLE**

(57) A flavor generation article (10) has a casing (12) constituted by first and second portions (12a, 12b) that are detachably connected to each other. A gas flow path (26) is formed in the casing first portion (12a) to extend from an air intake port (24) to reach a suction port (22). The first portion (12a) incorporates a material container (32) of a liquid material (36) containing a flavor substance. A discharge port (35) of the material

container (32) is arranged in the gas flow path (26), and a ceramic heater (42) is disposed to oppose it. The liquid material (36) is supplied from the discharge port (35) onto the ceramic heater (42) and is heated, so that it is gasified in the gas flow path (26). The casing second portion (12b) incorporates a control circuit (72) and a power supply (62).

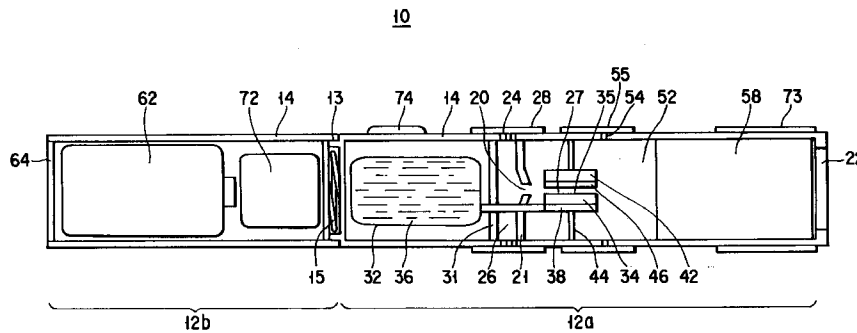

**FIG. 1**

**EP 0 845 220 A1**

The present invention relates to a flavor generation article employed for enjoying inhalation of a flavor and simulated smoking and, more particularly, to a flavor generation article used for generating the flavor as an inhalation target by heating a liquid material with an electric heater.

## Background Art

A simulated smoking article employed for enjoying the flavor and smoke of tobacco without burning tobacco is already known, and various types of simulated smoking articles have been proposed.

Jpn. Pat. Appln. KOKAI Publication No. 3-232481 discloses a typical concept of a conventional simulated smoking article. The article of this reference uses, e.g., a rod-like solid material. When the solid material is heated by a heating element, an inhalation target, e.g., a flavor, is generated. The drawbacks of the article of this type are as follows. When the solid material is continuously heated, the material is largely wasted. Inversely, when the solid material is heated in accordance with inhalation of the user, a large time lag occurs between the start of inhalation (one puffing operation) of the user and generation of the flavor.

As an example of an article that copes with the above drawbacks, Jpn. Pat. Appln. KOKAI Publication No. 3-277265 discloses a flavor emitting article having a solid material divided into a large number of portions. In the article of this reference, the respective portions of the solid material are sequentially heated in units of puffing operations of the user to generate an inhalation target, e.g., a flavor or the like. The drawback of this article is that the solid material and a heating element constitute an integral flavor generation medium. Therefore, when the material is consumed, the heating element must be exchanged or disposed of together with the material, which is not preferable both in terms of economy and environment.

Jpn. Pat. Appln. KOKAI Publication No. 5-212100 discloses an example of a mechanism that detects one puffing operation of the user. In the article of this reference, the driving operation of a heating element for heating the flavor material is controlled by a signal obtained from the motion of the lips of the user.

U.S.P. No. 4,945,931 discloses a simulated smoking article using a pressurized aerosol container. In the article of this reference, the puffing operation of the user swings the vanes to mechanically open the outlet port of the container, and the aerosol is emitted. As a modification, this reference also discloses an article in which a heating element for heating aerosol cooled by the heat of evaporation is disposed in the outlet port of the container. The drawback of this reference is as follows.

5 ically, in the article of this reference, a predetermined amount of aerosol appropriate for one puffing operation cannot be continuously emitted, and rather all of the pressurized flavor gas may undesirably be emitted until a puffing operation is complete twice or three times.

## Disclosure of Invention

The present invention has been made in view of the above problems, and has as its object to provide a flavor generation article in which waste of a flavor material does not occur easily and the timing of one puffing operation of the user and that of generation of a flavor can be matched easily.

According to the first aspect of the present invention, there is provided a flavor generation article characterized by comprising:

- a casing having an air intake port for taking in air therein and a suction port through which a user inhales a flavor, and forming a gas flow path between the intake port and the suction port;
- a material container for storing a liquid material which contains at least a flavor substance and having a discharge port for the material, the material container being mounted on the casing;
- discharge driving means for discharging the material from the container through the discharge port in the form of a liquid drop;
- gasifying means disposed in the gas flow path to receive the liquid drop of the material discharged from the container and gasify the material by electrically heating the liquid drop; and
- a power supply for supplying electric energy to the gasifying means.

According to the second aspect of the present invention, there is provided a flavor generation article in the first aspect, characterized by further comprising a sensor for detecting an inhaling operation of the user and control means for controlling, based on a signal from the sensor, the discharge driving means so as to discharge the material from the container.

According to the third aspect of the present invention, there is provided a flavor generation article in the second aspect, characterized in that the sensor comprises a pressure-sensitive sensor mounted on the casing around the suction port.

According to the fourth aspect of the present invention, there is provided a flavor generation article in the second or third aspect, characterized in that the control means controls the gasifying means based on the signal from the sensor so that the gasifying means generates heat.

controls the gasifying means and the discharge driving means so as to preheat the gasifying means prior to discharge of the material.

According to the sixth aspect of the present invention, there is provided a flavor generation article in the first aspect, characterized in that the power supply is disposed in the casing.

According to the seventh aspect of the present invention, there is provided a flavor generation article in the sixth aspect, characterized in that the casing is constituted by first and second portions that are electrically connected to each other through a cable, the gas flow path, the container, the discharge driving means, and the gasifying means being disposed in the first portion, and the power supply being disposed in the second portion.

According to the eighth aspect of the present invention, there is provided a flavor generation article in the seventh aspect, characterized in that the first and second portions of the casing are detachably connected to each other through a connecting portion.

According to the ninth aspect of the present invention, there is provided a flavor generation article in the first aspect, characterized by further comprising an operation lever for manually operating the discharge driving means.

According to the 10th aspect of the present invention, there is provided a flavor generation article in any one of first to ninth aspects, characterized in that the gasifying means comprises a porous layer, and the liquid drop of the material is supplied onto the porous layer.

According to the 11th aspect of the present invention, there is provided a flavor generation article in any one of the first to 10th aspects, characterized in that the gasifying means is arranged to oppose the discharge port, and a throttle hole for directing air flowing from the air intake port toward a gap between the discharge port and the gasifying means is disposed in the gas flow path.

According to the 12th aspect of the present invention, there is provided a flavor generation article in any one of first to 11th aspects, characterized in that the casing is formed with an outer air inlet hole to supply an outer air into the gas flow path between the gasifying means and the suction port.

According to the 13th aspect of the present invention, there is provided a flavor generation article in any one of first to 12th aspects, characterized by further comprising a formed body of a solid material containing at least a flavor substance and disposed in the gas flow path so as to be located between the gasifying means and the suction port.

According to the 14th aspect of the present invention, there is provided a flavor generation article in the

5 material does not occur easily and the timing of one puffing operation of the user and that of generation of a flavor can be matched easily. In particular, when the discharge driving means is controlled based on a signal from a sensor that detects the inhaling operation of the user, not only waste of the material is eliminated, but also a stable flavor can constantly be provided. When the casing is divided into a portion incorporating a power supply and a portion to be held by the mouth such that the two portions are detachable from each other, the flavor generation article can be used more conveniently.

#### Brief Description of Drawings

20 FIG. 1 is a schematic view showing a flavor generation article according to an embodiment of the present invention;  
FIG. 2 is a plan view showing the discharge head of the flavor generation article shown in FIG. 1;  
FIG. 3 is an enlarged schematic view showing the discharge head and discharge drive portion taken along the line III - III of FIG. 2;  
FIG. 4 is a diagram showing the control system of the flavor generation article shown in FIG. 1;  
FIG. 5 is a view showing the state of use of the flavor generation article shown in FIG. 1;  
FIG. 6 is a graph showing an example of operation timing of energization of the ceramic heater and that of actuation of the discharge drive portion, of the flavor generation article shown in FIG. 1;  
FIG. 7 is a graph showing another example of operation timing of energization of the ceramic heater and that of actuation of the discharge drive portion, of the flavor generation article shown in FIG. 1;  
FIG. 8 is a schematic view showing a flavor generation article according to another embodiment of the present invention;  
FIG. 9 is a schematic view showing a flavor generation article according to still another embodiment of the present invention,  
FIG. 10 is a schematic view showing a flavor generation article according to still another embodiment of the present invention;  
FIG. 11 is a schematic view showing a flavor generation article according to still another embodiment of the present invention;  
FIG. 12 is a schematic view showing a flavor generation article according to still another embodiment of the present invention;  
FIG. 13 is a schematic view showing a flavor generation article according to still another embodiment of the present invention;  
FIG. 14 is a schematic view showing a flavor gener-

ation article according to still another embodiment of the present invention; and  
FIG. 16 is a schematic view showing a flavor generation article according to still another embodiment of the present invention.

### Best Mode of Carrying Out the Invention

FIG. 1 is a schematic view showing a flavor generation article according to an embodiment of the present invention.

A flavor generation article 10 has a cylindrical casing 12 having such an outer diameter that the user can hold the casing 12 in his mouth. The casing 12 comprises a first portion 12a to be held by the user's mouth, and a second portion 12b for incorporating a power supply and the like. The two portions 12a and 12b are detachably connected to each other through a connecting portion 13 formed on a casing main body 14. The two portions 12a and 12b are electrically connected to each other through a cable 15 stored in a space formed in the casing main body 14 to correspond to the connecting portion 13. As the connecting portion 13, a known structure, e.g., a screw or a fitting pair, can be employed. The main body 14 of the casing 12 is made of a material, e.g., a plastic, metallic, ceramic, or wooden material.

A suction port 22 through which the user inhales the flavor is formed in the end portion of the first portion 12a of the casing 12. In contrast to this, a plurality of air intake ports 24 for taking in air into the casing 12 are formed in the intermediate portion of the first portion 12a. A gas flow path 26 is defined in the casing 12 between the air intake ports 24 and the suction port 22. The air intake ports 24 can be formed to have an open area corresponding to a predetermined air intake amount. As shown in FIG. 1, an adjusting ring 28 having a plurality of openings can be disposed on the casing 12 around the air intake ports 24. In this case, the amount of air flowing into the casing 12 can be adjusted by adjusting the position of the adjusting ring 28 with respect to the air intake ports 24.

A throttle plate 21 having a throttle hole 20 at its center is disposed in the casing 12 to be located in the gas flow path 26. The throttle hole 20 serves to regulate air from the air intake ports 24 to flow along the surface of a ceramic heater 42 (to be described later).

A material container 32 for storing a liquid material 36 for generating a flavor or the like to be inhaled by the user is detachably fixed in a space which is deep in the first portion 12a of the case and partitioned from the gas flow path 26 by a wall 31. The material container 32 stores the liquid material 36 in an amount corresponding to the discharge amount of a plurality of puffing operations of the user.

the casing main body 14, or only discharge ports 35 (to be described later) may be inserted in the casing main body 14.

The liquid material 36 contains at least a flavor substance. For example, if the liquid material 36 is an article used for enjoying only the flavor, e.g., menthol or caffeine, it can be a material that generates only the flavor. Also, in order to add smoke to the flavor, the liquid material 36 can contain a material which generates aerosol when heated. As the material that generates aerosol, alcohols, saccharide, or water, or a mixture of at least two of these components can be used. The alcohols used in this case are, e.g., glycerin or propylene glycol, or their mixture.

More specifically, the liquid material 36 can contain an extracted material and/or the constituent components of various types of natural materials in accordance with the application purpose. For example, if this article is used as a simulated smoking article, a tobacco component, e.g., a tobacco extracted component or a tobacco smoke condensate component, may be contained in the liquid material 36.

The material container 32 is formed with a discharge head 34 having the plurality of discharge ports 35 for discharging the liquid material 36 in a transverse direction of the casing 12. The discharge head 34 is arranged to be located closer to the suction port 22 than the throttle hole 20. A discharge drive portion 38 is disposed adjacent to the discharge ports 35 to discharge the liquid material 36 from the material container 32 through the discharge ports 35. The discharge head 34 and the discharge drive portion 38 comprise a liquid discharge mechanism (having the same principle as that of the method shown in Jpn. Pat. Appln. KOKOKU Publication No. 53-45698 and U.S.P. No. 3,596,275) utilizing a piezoelectric element.

For example, as shown in FIG. 2, 10 discharge ports 35 are arranged for two rows, leading to a total of 20 discharge ports 35 in a region with a width W of about 2 mm and a length L of about 5 mm of the upper surface of the discharge head 34. The center of arrangement of the discharge ports 35 almost coincides with the center of the ceramic heater 42 (to be described later).

FIG. 3 is an enlarged schematic view showing the discharge head 34 and discharge drive portion 38 taken along the line III - III of FIG. 2. More specifically, FIG. 3 shows a section corresponding to one row of the discharge ports 35. A section corresponding to the other row of the discharge ports 35 and the section shown in FIG. 3 are horizontally symmetrical.

As shown in FIG. 3, a frame 134 constituted by a plurality of components is stacked on a wiring board 132 to form recessed portions and holes to be filled with the liquid material 36. The recessed portions formed by the

store the liquid material 36. The bottom plate of the liquid reservoir 146 is constituted by an electrode 138 that serves as a vibration plate.

The liquid material 36 from the material container 32 is supplied first through a narrow flow path 142, and flows from a plurality of suction holes 144, having a smaller diameter than that of the discharge ports 35, to reach the liquid reservoir 146. Under the control of a control circuit 72, when the electrode 138 is operated to vibrate, the liquid material 36 is selectively discharged through the discharge ports 35 having a low resistance against the flow. The discharged liquid material 36 is supplied onto the ceramic heater 42 as a liquid drop LD.

Other than this, as the discharge mechanism of the liquid material 36, a known printer ink discharge mechanism can be modified and employed, e.g., a method disclosed in Jpn. Pat. Appln. KOKOKU Publication No. 61-59911 and the like wherein the process liquid is injected by bubbles generated by heating it, or a method disclosed in U.S.P. No. 3,060,429 and the like wherein the particles of the process liquid are electrified to perform electric field control. Alternatively, a discharge mechanism in which a liquid material 36 is a pressurized liquid and is controlled by opening/closing a valve disposed in a discharge ports 35 may be employed.

The ceramic heater 42 is disposed in the gas flow path 26 to oppose the discharge ports 35. The ceramic heater 42 is fixed on the inner surface of the casing main body 14 through a support member 44. A gap 27 between the discharge ports 35 of the discharge head 34 and the ceramic heater 42 is set such that air from the throttle hole 20 can flow through it. Accordingly, air from the air intake ports 24 is directed by the throttle hole 20 to the gap 27 between the discharge ports 35 and ceramic heater 42.

A material corresponding to one puffing operation, which is driven by the discharge drive portion 38 and emitted from the discharge ports 35 is supplied onto the ceramic heater 42 in the form of a liquid splash or liquid drop. The ceramic heater 42 is constituted by a ceramic plate and a coated resistance heater on the ceramic plate, and is accordingly an integral member of a catch pan for receiving the splash of the material and a heating means for heating the catch pan. However, the catch pan and the heating means can be disposed as separate components.

A liquid-absorbing porous layer 46 having a thickness of 0.01 mm to 2.0 mm, e.g., an activated carbon layer having a thickness of about 0.5 mm, is formed on a surface of the ceramic heater 42 that receives the liquid splash of the material, i.e., a surface of the ceramic heater 42 that serves as the catch pan. The porous layer 46 not only protects the surface of the ceramic heater 42 but also relaxes heat conduction from the ceramic heater 42, thereby stabilizing gasification of the

ganic compound, e.g., carbon (including activated carbon), alumina, or silicon carbide. The porous layer 46 can have an arbitrary shape. For example, the compound mentioned above may be formed as a formed body in advance, e.g., a film, a sheet, a plate, fabric, or unwoven fabric, and be used as the porous layer 46. Alternatively, the porous layer 46 may be formed by directly applying the powder of the component mentioned above on the ceramic heater 42.

A cooling chamber 52 is formed between the ceramic heater 42 and the suction port 22 to constitute part of the gas flow path 26. Outer air inlet holes 54 are formed in the side wall of the casing main body 14 defining the cooling chamber. The gas heated by the ceramic heater 42 and containing a flavor is mixed with the outer air and cooled in the cooling chamber 52, and reaches the suction port 22. The outer air inlet holes 54 can be formed to have an open area corresponding to a predetermined air inlet amount. As shown in FIG. 1, an adjusting ring 55 having a plurality of openings can be disposed on the casing 12 around the outer air inlet holes 54. In this case, the amount of outer air flowing into the cooling chamber 52 can be adjusted by adjusting the position of the adjusting ring 55 with respect to the outer air inlet holes 54.

A filter 58 is disposed in the gas flow path 26 between the cooling chamber 52 and suction port 22 to cover the suction port 22. When the filter 58 is disposed, the pressure loss can be adjusted so that the flavor component can be inhaled with an appropriate pressure. The filter 58 can be made of a normal tobacco filter material made of cellulose acetate, pulp, or the like.

A power supply 62 is detachably fixed in the second portion 12b of the casing 12. The power supply 62 is used to supply electric energy to the discharge drive portion 38, the ceramic heater 42, and the control circuit 72 (to be described later). The power supply 62 can be mounted in and removed from the casing main body 14 by opening/closing a cap 64 that closes the rear opening of the casing main body 14. The power supply 62 is preferably a DC power supply, e.g., a commercially available dry cell or rechargeable cell. However, the power supply 62 can be an AC power supply. The power supply 62 can be mounted on the outer side of the casing main body 14, or can be provided separately and connected to the casing main body 14 with a wire.

The control circuit 72 for controlling the driving operation of the discharge drive portion 38 and the ceramic heater 42 is arranged between the power supply 62 and material container 32. As shown in FIG. 4, the control circuit 72 has a signal processing circuit 72a, a drive circuit 72b, and a power circuit 72c. The signal processing circuit 72a is connected to a sensor 73 for detecting the inhaling operation of the user and a manual ON/OFF switch 74. The drive circuit 72b is con-

# Explore Litigation Insights

Docket Alarm provides insights to develop a more informed litigation strategy and the peace of mind of knowing you're on top of things.

## Real-Time Litigation Alerts



Keep your litigation team up-to-date with **real-time alerts** and advanced team management tools built for the enterprise, all while greatly reducing PACER spend.

Our comprehensive service means we can handle Federal, State, and Administrative courts across the country.

## Advanced Docket Research



With over 230 million records, Docket Alarm's cloud-native docket research platform finds what other services can't. Coverage includes Federal, State, plus PTAB, TTAB, ITC and NLRB decisions, all in one place.

Identify arguments that have been successful in the past with full text, pinpoint searching. Link to case law cited within any court document via Fastcase.

## Analytics At Your Fingertips



Learn what happened the last time a particular judge, opposing counsel or company faced cases similar to yours.

Advanced out-of-the-box PTAB and TTAB analytics are always at your fingertips.

## API

Docket Alarm offers a powerful API (application programming interface) to developers that want to integrate case filings into their apps.

## LAW FIRMS

Build custom dashboards for your attorneys and clients with live data direct from the court.

Automate many repetitive legal tasks like conflict checks, document management, and marketing.

## FINANCIAL INSTITUTIONS

Litigation and bankruptcy checks for companies and debtors.

## E-DISCOVERY AND LEGAL VENDORS

Sync your system to PACER to automate legal marketing.