



US005623104A

United States Patent [19]

[11] Patent Number: **5,623,104**

Suga

[45] Date of Patent: **Apr. 22, 1997**

[54] **APPARATUS FOR TESTING POWER PERFORMANCE OF ELECTRIC MOTOR FOR ELECTRIC VEHICLE**

5,262,717 11/1993 Bolegoh .

FOREIGN PATENT DOCUMENTS

[75] Inventor: **Hiroshi Suga**, Toyoake, Japan

59-104571 6/1984 Japan .

59-111071 6/1984 Japan .

3-212194 9/1991 Japan .

[73] Assignee: **Toyota Jidosha Kabushiki Kaisha**, Toyota, Japan

4-348289 12/1992 Japan .

6-66653 3/1994 Japan .

[21] Appl. No.: **593,971**

Primary Examiner—Richard Chilcot

Assistant Examiner—Ronald Biegel

[22] Filed: **Jan. 30, 1996**

Attorney, Agent, or Firm—Oblon, Spivak, McClelland, Maier & Neustadt, P.C.

[30] Foreign Application Priority Data

Mar. 10, 1995 [JP] Japan 7-051385

[57] ABSTRACT

[51] Int. Cl.⁶ **G01L 3/00**

[52] U.S. Cl. **73/862.18; 73/862.17; 73/117**

[58] Field of Search 73/862.18, 862.17, 73/862.09, 117, 117.1; 364/551.01

A test motor 2 is controlled by a controller 7 in accordance with travelling pattern (i.e. vehicle speed) data of an electric vehicle. A load motor 3 is controlled by a controller 9 in accordance with a load pattern. A host controller 10 generates the load pattern based on the vehicle speed pattern and factors of the electric vehicle, and synchronously outputs the vehicle speed pattern and the load pattern to the controller 7 and 9, respectively. Data detected by a torque sensor 4 or other measuring element are input to the host controller 10 to generate a two-dimensional map showing the relationship between the motor efficiency and motor output, or between the motor efficiency and revolution speed. Since the load pattern is generated and input in advance without using feedback control, test results can be obtained with high accuracy.

[56] References Cited

U.S. PATENT DOCUMENTS

- 3,898,875 8/1975 Knoop et al. 73/862.18
- 4,257,261 3/1981 Ono et al. 73/862.18
- 4,382,388 5/1983 Ono 73/862.18
- 4,422,040 12/1983 Raider et al. .
- 4,442,708 4/1984 Gable et al. 73/862.18
- 4,672,288 6/1987 Abbondanti .
- 4,860,231 8/1989 Ballard et al. .
- 4,965,513 10/1990 Haynes et al. .

6 Claims, 10 Drawing Sheets .

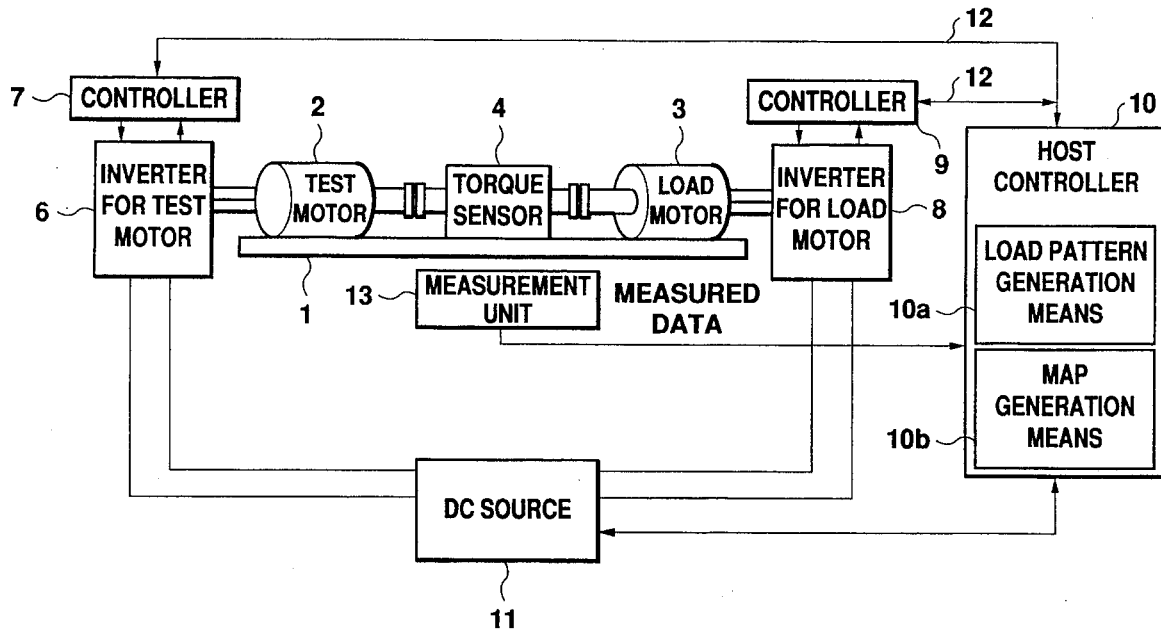

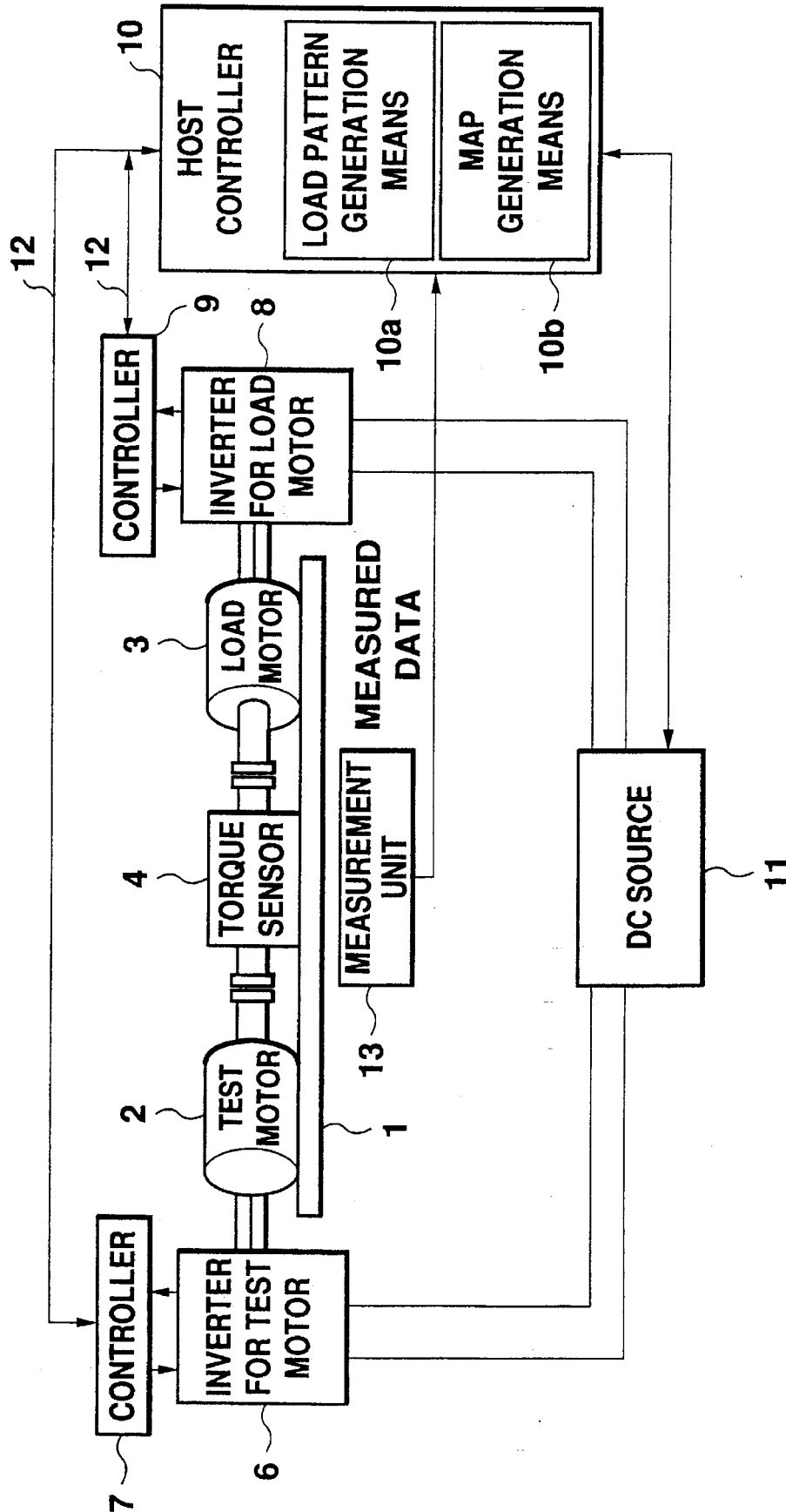
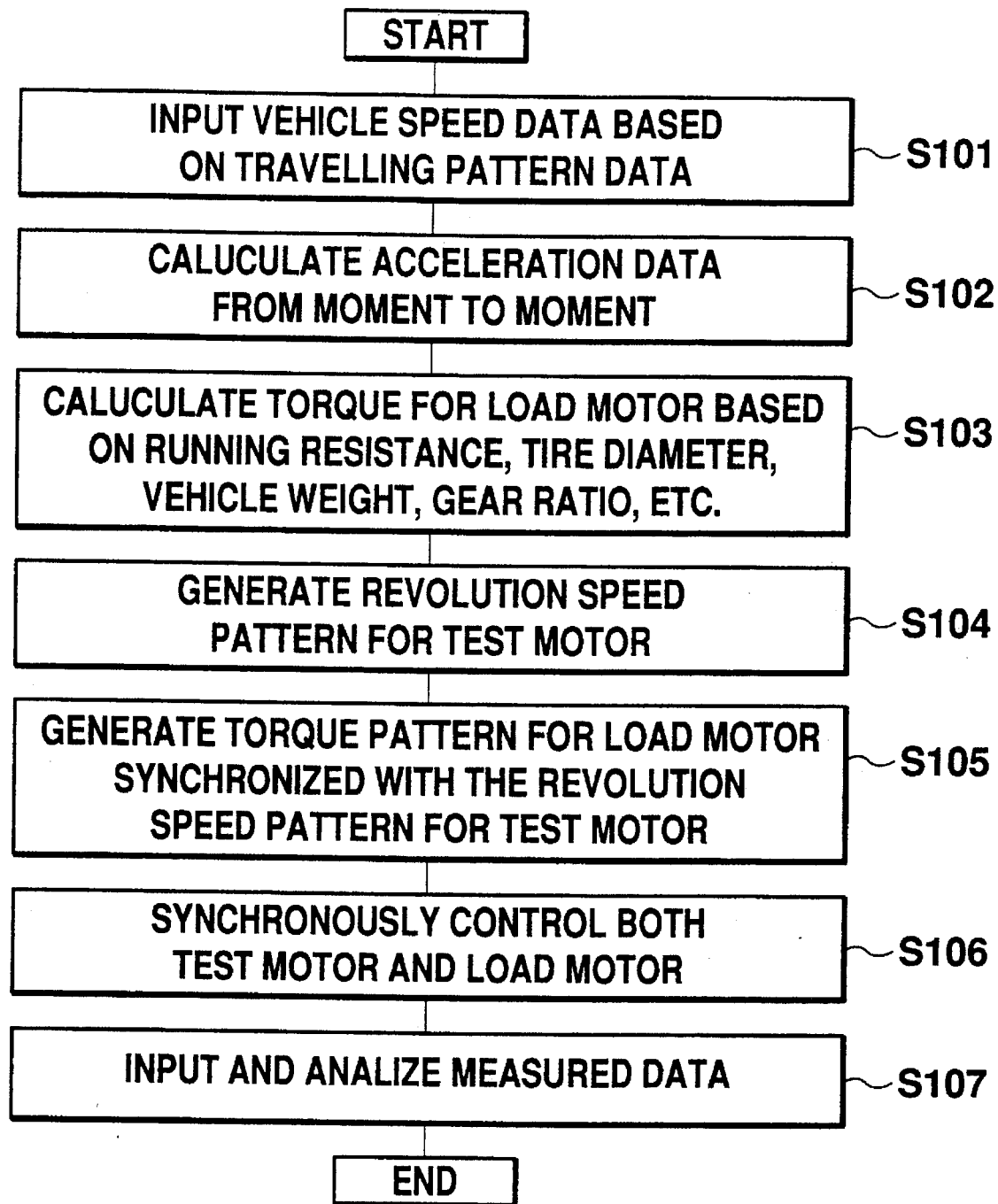

Fig. 1

**Fig. 2**

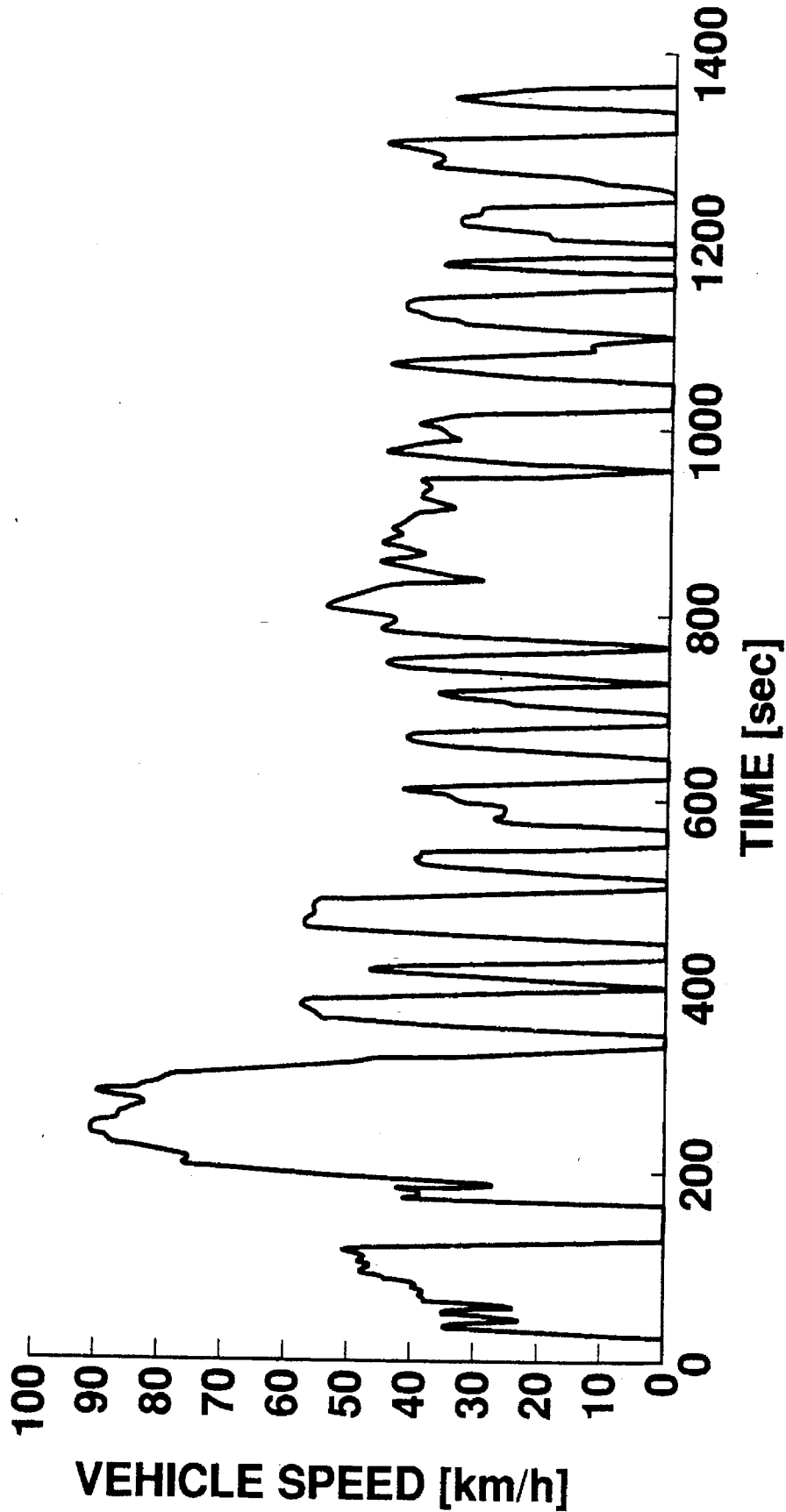

Fig. 3

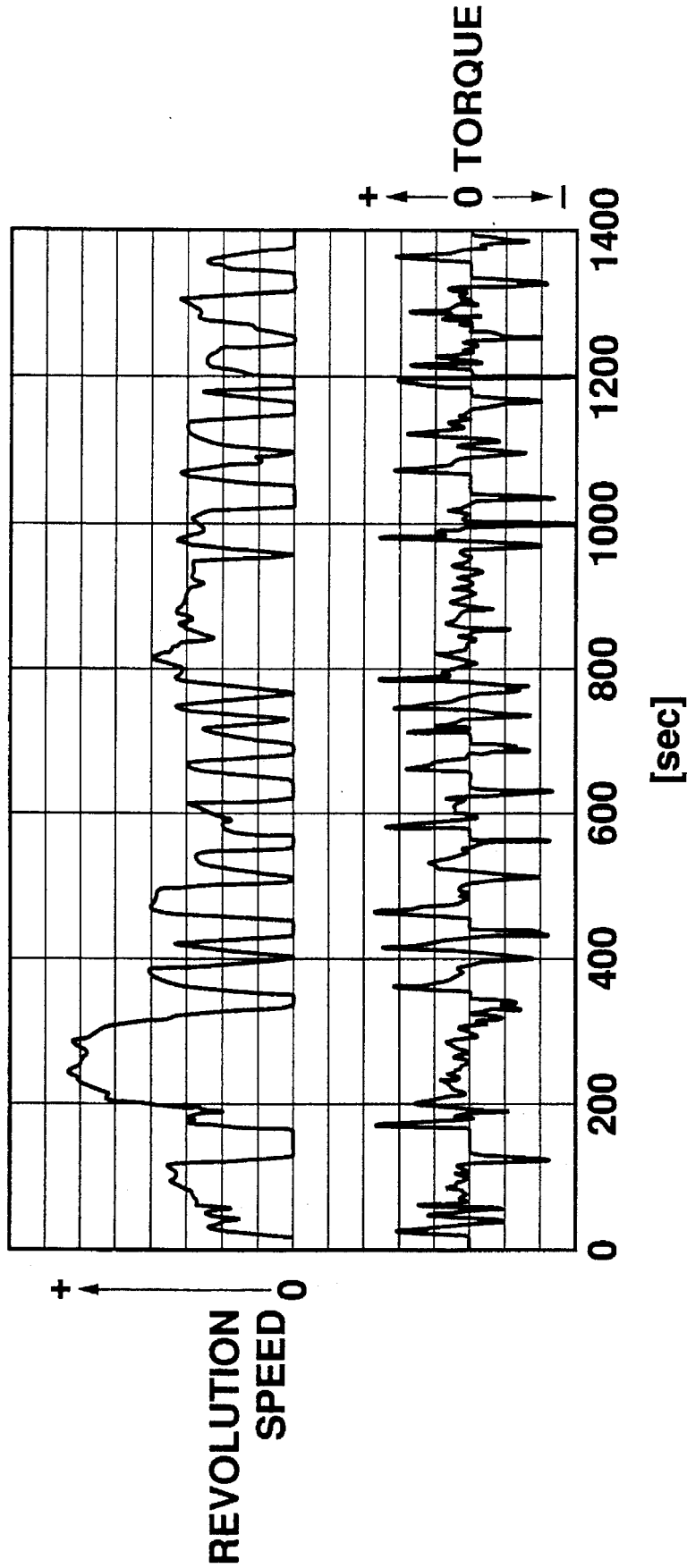

Fig. 4

Explore Litigation Insights

Docket Alarm provides insights to develop a more informed litigation strategy and the peace of mind of knowing you're on top of things.

Real-Time Litigation Alerts



Keep your litigation team up-to-date with **real-time alerts** and advanced team management tools built for the enterprise, all while greatly reducing PACER spend.

Our comprehensive service means we can handle Federal, State, and Administrative courts across the country.

Advanced Docket Research



With over 230 million records, Docket Alarm's cloud-native docket research platform finds what other services can't. Coverage includes Federal, State, plus PTAB, TTAB, ITC and NLRB decisions, all in one place.

Identify arguments that have been successful in the past with full text, pinpoint searching. Link to case law cited within any court document via Fastcase.

Analytics At Your Fingertips



Learn what happened the last time a particular judge, opposing counsel or company faced cases similar to yours.

Advanced out-of-the-box PTAB and TTAB analytics are always at your fingertips.

API

Docket Alarm offers a powerful API (application programming interface) to developers that want to integrate case filings into their apps.

LAW FIRMS

Build custom dashboards for your attorneys and clients with live data direct from the court.

Automate many repetitive legal tasks like conflict checks, document management, and marketing.

FINANCIAL INSTITUTIONS

Litigation and bankruptcy checks for companies and debtors.

E-DISCOVERY AND LEGAL VENDORS

Sync your system to PACER to automate legal marketing.