

MAN-005500-000
Rev. 1.3
November 21, 1996

CRD-5500

SCSI RAID Controller User's Manual

CMD Technology, Inc.
1 Vanderbilt
Irvine, California 92618
(714) 454-0800

Trademarks and Copyright

CMD, CMD Technology, and CRD-5500 are trademarks of CMD Technology, Inc. All other product and company names are trademarks or registered trademarks of other manufacturers.

Copyright © CMD Technology, Inc. 1996. All rights reserved.

CMD reserves the right to make changes to this manual and the equipment described in this manual without notice. CMD has made all reasonable efforts to ensure that the information in this manual is accurate and complete. CMD will not be liable, however, for any technical or editorial errors or omissions made in this manual, or for incidental, special, or consequential damage of whatsoever nature, resulting from the furnishing of this manual, or operation and performance of equipment in connection with this manual.

FCC Notice

This equipment has been tested and found to comply with the limits of a Class B digital device, pursuant to Part 15 of the FCC rules. These limits are designed to provide reasonable protection against harmful interference in a residential installation. This equipment generates, uses and can radiate radio frequency energy and, if not installed and used in accordance with the instructions, may cause harmful interference to radio communications. However, there is no guarantee that interference will not occur in a particular installation. If this equipment does cause harmful interference to radio or television reception, which can be determined by turning the equipment off and on, the user is encouraged to try to correct the interference by one or more of the following measures:

- Reorient or relocate the receiving antenna.
- Increase the separation between the equipment and receiver.
- Connect the equipment into an outlet on a circuit different from that to which the receiver is connected.
- Consult the dealer or an experienced radio/TV technician for help.

Any changes or modifications not expressly approved by the manufacturer could void the user's authority to operate the equipment.

Statement of License Limitations

CMD is licensed under patents by EMC which contain claims directly applicable to controllers. The purchase of this controller product does not expressly nor impliedly license the purchaser to combine or use the product in combination with any other products or components which combination would be covered by EMC patent claims applicable to RAID subsystems. As used herein, controllers means a single or multi-processor device or group of functionally interrelated devices operable to physically and/or logically configure a plurality of physical mass storage devices as one or more independently accessible arrays, and to control the communication of data between the array(s) and host(s) or client(s) in a predetermined RAID format or other formats. RAID subsystems means a storage subsystem including one or more arrays of physical mass storage devices, and one or more controllers associated therewith.

Declaration of Conformity

CMD Technology, Inc. declares that the equipment described in this document is in conformance with the requirements of the European Council Directives listed below:

89/336/EEC EMC Directive
93/68/EEC EMC Directive

On the approximation of the laws of Member States relating to Electromagnetic Compatibility.

This declaration is based upon compliance of the product to the following standards:

EN 55022, CISPR 22B RF Emissions Control
EN 50082-1 IEC 801 Immunity to Electromagnetic Disturbances

Product Description: RAID SCSI to SCSI Interface
Model: CRD-5500



Manufacturer: CMD Technology, Inc.
 1 Vanderbilt
 Irvine, California 92618 (USA)

Warranty

CMD Technology warrants this product to be free of defects in materials and/or workmanship for a period of 3 years from the date of purchase. If the product proves to be defective within the warranty period, CMD Technology will either repair or replace it. This warranty covers defects incurred in normal use only. Defects, malfunctions, or failures resulting from accidents, misuse, or mishandling are not covered. In the event that this product must be repaired or replaced, please contact CMD for an RMA number.

Note

CMD has tested and certified this product in the configuration as delivered. Failure to verify any proposed modification or change in configuration with CMD Technical Support or Sales may result in improper operation or damage to the product.

This page left blank intentionally.



Table of Contents

1	About the CRD-5500	1-1
1.1	Modular Hardware Design.....	1-1
1.2	Flexible RAID Set Configuration.....	1-1
1.3	Performance Enhancements	1-3
1.3.1	Custom Components	1-3
1.3.2	Efficient Write and Read Algorithms	1-3
1.3.2.1	<i>Write-Back Caching</i>	1-4
1.3.2.2	<i>Write Gathering</i>	1-4
1.3.2.3	<i>Write On Top</i>	1-4
1.4	RAID Levels Supported	1-5
1.4.1	RAID 0.....	1-5
1.4.2	RAID 1.....	1-6
1.4.3	RAID 0+1.....	1-7
1.4.4	RAID 4.....	1-8
1.4.5	RAID 5.....	1-9
1.4.6	JBOD.....	1-10
1.5	A Few Words About Compatibility	1-11
2	Setup Guidelines	2-1
2.1	Installing Modules.....	2-1
2.1.1	How To Tell the Modules Apart	2-1
2.2	Disk Drives	2-3
2.2.1	Drive Geometry	2-3
2.2.1.1	<i>Drive Geometry Example</i>	2-4
2.3	SCSI Bus Setup.....	2-4
2.4	Cache	2-5
2.4.1	How To Order SIMMs.....	2-5
2.4.2	Installing SIMMs.....	2-6
2.5	Warning Alarm	2-6
2.6	Battery Backup.....	2-7



2.7	Fan	2-8
2.8	Connecting to a Monitor	2-9
2.8.1	Using the Terminal Program in Microsoft Windows	2-9
<hr/>		
3	Configuration Example	3-1
3.1	Connecting the Drives	3-1
3.2	Setting Up the Host Interface	3-1
3.3	Creating a RAID Set	3-3
3.3.1	How To Create a RAID Set	3-3
3.3.2	Creating a RAID Set with Multiple Partitions	3-5
3.4	Designating Spare Drives	3-6
3.5	Rebuilding a Disk Drive	3-7
<hr/>		
4	Using the Monitor Utility	4-1
4.1	Navigating the Menu Tree	4-1
4.2	RAID Information	4-1
4.3	Setup Parameters	4-2
4.3.1	Host Parameters	4-3
4.3.2	System Parameters	4-4
4.3.3	Host LUN Mapping	4-5
4.3.4	Channel Settings	4-5
4.4	System Information	4-6
4.5	RAID Set Functions	4-7
4.5.1	Create RAID Set	4-8
4.5.1.1	Deleting a RAID Set	4-11
4.5.2	Rebuild Disk	4-12
4.5.3	Add Spares	4-13
4.6	System Functions	4-14
4.6.1	Change Password	4-14
4.6.2	If You Forget Your Password	4-14
4.6.3	Load System Code	4-14
4.6.4	Restart System	4-16
4.6.5	System Shutdown	4-16
4.6.6	Download Drive Firmware	4-17
4.7	Disk Utilities	4-17



4.8	Debug Utilities.....	4-17
4.9	Rebuild/Create Status.....	4-17
4.10	Event Log.....	4-18

5	Front Panel	5-1
5.1	Main Menu	5-1
5.1.1	RAID Set Status	5-1
5.1.2	Front Panel Tests.....	5-1

6	CRD-5500 Redundant RAID Controller Kit	6-1
6.1	Introduction.....	6-1
6.2	Requirements.....	6-1
6.3	SIMM Installation.....	6-3
6.4	RCC Cable Connection.....	6-5
6.5	Single-Host Configuration Examples.....	6-7
6.6	Multiple-Host Configuration Examples.....	6-10
6.7	Configuring the Redundant Controller Mode.....	6-16
6.8	Restart After Switchover	6-23

A	Warranty	A-1
	Return and Repair Policy	A-2
	Return for Repair	A-2
	Shipping Charges	A-3



This page left blank intentionally.



1 About the CRD-5500

The CRD-5500 RAID controller provides high-performance, high-availability access to SCSI disk array subsystems along a Fast/Wide SCSI bus. With a modular hardware design and an intuitive configuration utility, the controller may be tailored to suit a wide range of storage needs, now and in the future. The CRD-5500 is largely compatible with CMD's CRD-5000 RAID controller, so owners of that controller should be able to upgrade by doing nothing more than connecting the CRD-5500 to their existing RAID sets.

Note

The CRD-5500 does not support RAID level 3 or RAID level 0 with a one-block chunk size. Such RAID sets created on the CRD-5000 may not be transferred to the CRD-5500.

1.1 Modular Hardware Design

The CRD-5500 employs a modular design for maximum flexibility. You may customize your controller using a combination of 8-bit single-ended SCSI I/O modules, 16-bit single-ended modules, and 16-bit differential modules. The controller has nine I/O module slots. One of these slots is reserved for use as a host channel, and five are reserved for use as drive channels. The other three can serve as host or drive channels, depending on how they are configured in the controller's onboard configuration utility. This means that you can have one host channel and as many as eight disk channels. Or you can trade as many as three of the drive channels for host channels, resulting in a possible configuration of four host channels and as many as five drive channels.

1.2 Flexible RAID Set Configuration

In addition to its flexible hardware design, the CRD-5500's firmware offers the user the flexibility to configure RAID sets in many different ways:

- RAID sets may comprise drives from any drive channel and SCSI ID.
- A RAID set may contain all the drives connected to the controller, a single drive, or any number of drives in between.
- The controller supports RAID Levels 0, 1, 0+1, 4, and 5. It also supports "Just a Bunch of Drives" (JBOD), which permits you to connect standalone disk drives (such as a system disk) to the CRD-5500 without making them members of a RAID set.
- Each RAID set may be partitioned into smaller redundancy groups.
- The controller's Host LUN Mapping feature makes it possible to map RAID sets differently to each host. You make the same redundancy group show up on different LUNs to different hosts, or make a redundancy group visible to one host but not to another.
- Any drive may be designated as a hot or warm spare. Spares are global, meaning that in the event of a drive failure, the CRD-5500 will search for the first suitable spare on any channel or SCSI ID and automatically begin rebuilding the failed drive's data.

Figure 1-1 shows an example of how the controller's drives may be combined in various ways to suit different needs.

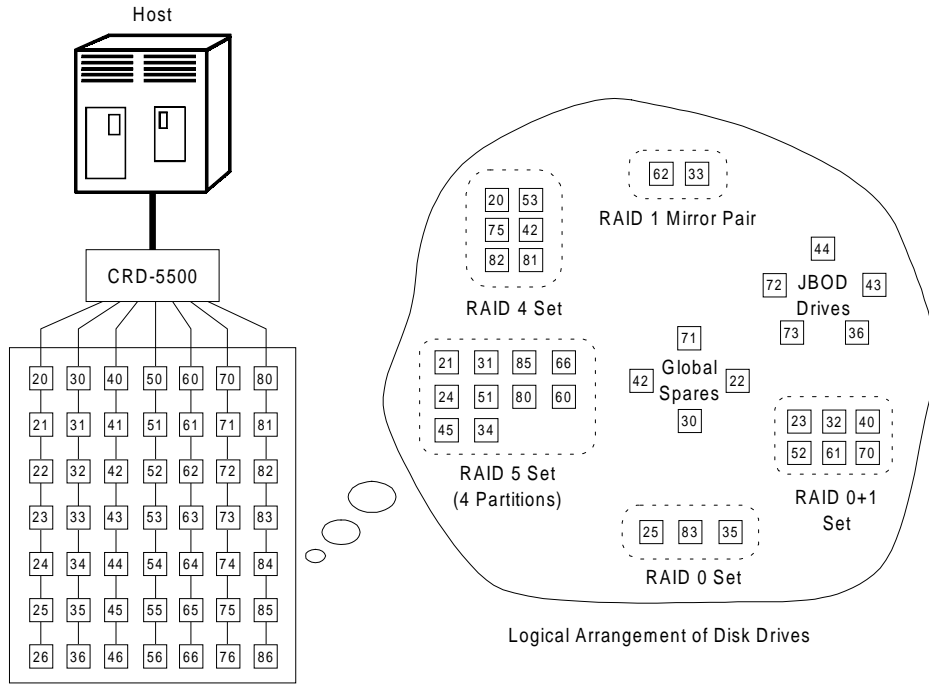

Physical Arrangement of Disk Drives

Figure 1-1: How the controller views RAID sets

Figure 1-2 shows how you can connect as many as four hosts to the CRD-5500. By using the controller's Host LUN Mapping feature, you can assign redundancy groups to a particular host. This makes it possible for hosts running incompatible operating systems to use the same CRD-5500 controller. If the hosts are part of a VMS VAXcluster™ they can share access to all of the redundancy groups.

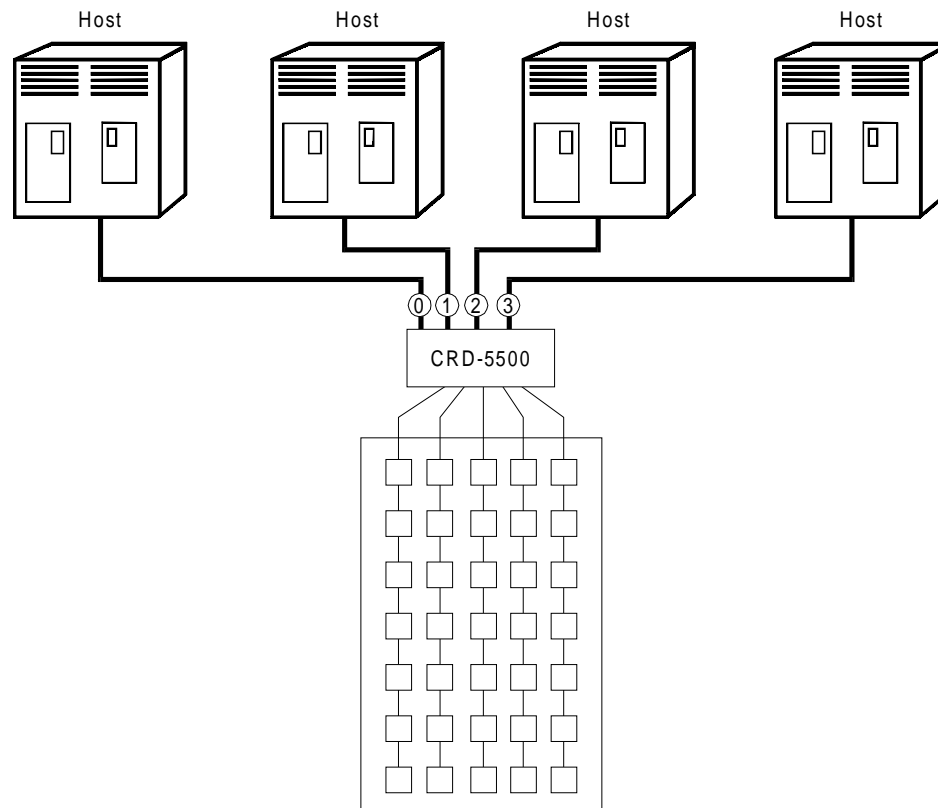

Figure 1-2: A multi-hosting example

1.3 Performance Enhancements

The CRD-5500 employs a number of techniques to achieve as much performance as possible from its design.

1.3.1 Custom Components

To increase performance and reliability, the CRD-5500's core functions have been encapsulated in four custom ASIC (Application Specific Integrated Circuits) components.

XOR ASIC: Used in the Exclusive-Or parity calculations employed by RAID levels 4 and 5.

DMA ASIC: Controls the data path hardware for the various I/O ports.

CPU Interface ASIC: Supports the controller's MIPS R3000 RISC central processing unit.

Memory Controller ASIC: Controls the memory system and supports data movement on the internal bus at a maximum burst rate of 80 MB/second and a maximum sustainable rate of 60 MB/second.

1.3.2 Efficient Write and Read Algorithms

Standard RAID write operations that involve parity, such as those in RAID levels 4 and 5, require multiple, time-consuming steps:



- 1 Read data from the parity drive.
- 2 Read existing data from the target data drives.
- 3 Exclusive-Or the old parity, old data, and new data to generate new parity data.
- 4 Write the new parity data to the parity drive.
- 5 Write the new data to the target data drives.

The CRD-5500 uses several techniques to streamline write operations and significantly improve performance. All the techniques use the controller's onboard cache, which can contain up to 512 megabytes of memory in the form of standard 72-pin, 60-nanosecond SIMMs.

Note

The CRD-5500 will not operate without at least one 4MB SIMM installed in its cache. Nor will it operate without either a battery backup or an uninterruptible power supply connected to the controller. Without a backup, data stored in the cache but not yet written to the disk drives would be lost in the event of a power interruption.

1.3.2.1 Write-Back Caching

When the host sends data to be written to a redundancy group, the controller stores the data in its cache and immediately reports to the host it has completed the write. The controller eventually writes the data to the disk drives, when the write can be done most efficiently or when the controller must flush the cache to make room for other data or to prepare for a shutdown.

Write-back caching makes the host more responsive to the user, since the host does not have to wait for a lengthy RAID write before processing another task.

1.3.2.2 Write Gathering

The CRD-5500 will attempt to consolidate multiple writes destined for contiguous blocks and then write the entire data block in one operation. The controller stores the data in cache until it performs the write. Ideally, the controller will wait until it has gathered enough data to fill an entire stripe. This enables the controller to avoid reading from the parity and data drives before making the write. All it has to do is calculate parity from the data it already has in its cache, then write the data and parity to the drives. Even if the controller cannot accumulate enough data to fill a stripe, the consolidation of multiple small writes can reduce the number of read/write operations that must take place.

1.3.2.3 Write On Top

If the host commands that data be written to disk, and data for that address is pending in the controller's cache, the controller writes the new data on top of the old in the cache. Only the new data is eventually written to the disk drives.



1.4 RAID Levels Supported

The CRD-5500 supports the following RAID levels:

RAID Level	Description
0	Striping without parity
1	Mirroring
0+1	Striping and mirroring
4	Striping with fixed parity drive
5	Striping with floating parity drive
JBOD	"Just a Bunch of Drives"

Note

The CRD-5500 stripes data in multi-block chunk sizes. If you are upgrading from a CRD-5000 and have a Level 0 RAID set with a single-block chunk size, you will have to recreate the RAID set to connect it to the CRD-5500.

1.4.1 RAID 0

RAID 0 breaks up data into smaller chunks and then writes each chunk to a different drive in the array. The size of each chunk is determined by the controller's chunk size parameter, which you set in the course of creating a RAID set.

The advantage of RAID 0 is its high bandwidth. By breaking up a large block of data into smaller chunks, the controller can use multiple drive channels to write the chunks to the disk drives. Furthermore, RAID 0 involves no parity calculations to complicate the write operation. Likewise, a RAID 0 read operation employs multiple drives to assemble a single, large data block. This makes RAID 0 ideal for applications, such as graphics, video, and imaging, that involve the writing and reading of huge, sequential data blocks.



RAID 0 Write

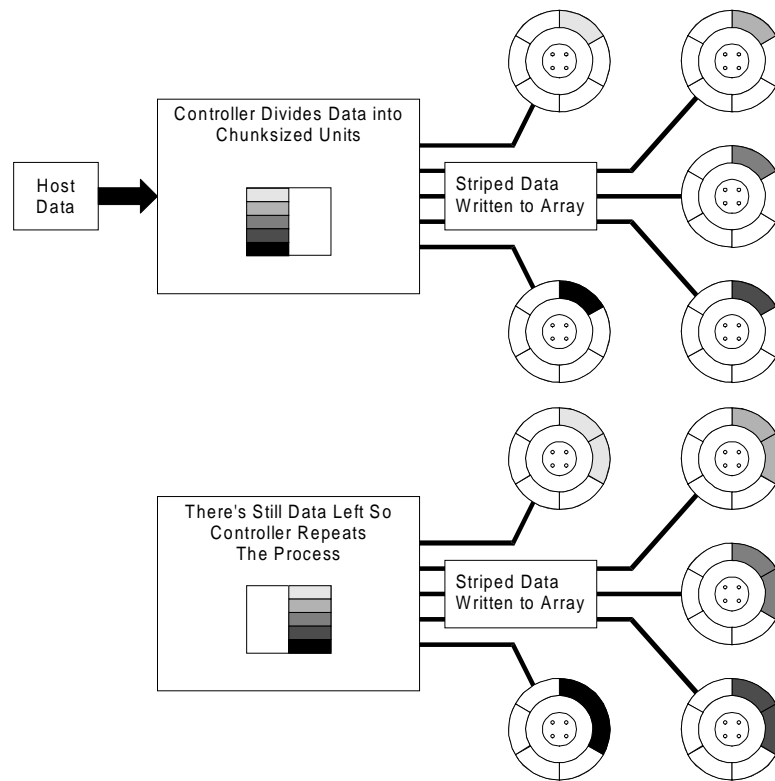

Figure 1-3: Diagram of a RAID 0 write

Warning

The lack of parity means that a RAID 0 disk array offers absolutely no redundancy and thus cannot recover from a drive failure.

1.4.2 RAID 1

RAID 1 (also known as mirroring or shadowing) takes data sent by the host and duplicates it on all the drives in the array. This results in a high degree of data availability, since you can lose all but one drive in the array and still have full access to your data. This comes at a price: a RAID 1 array requires multiple drives to achieve the storage capacity of a single drive.

RAID 1 Write

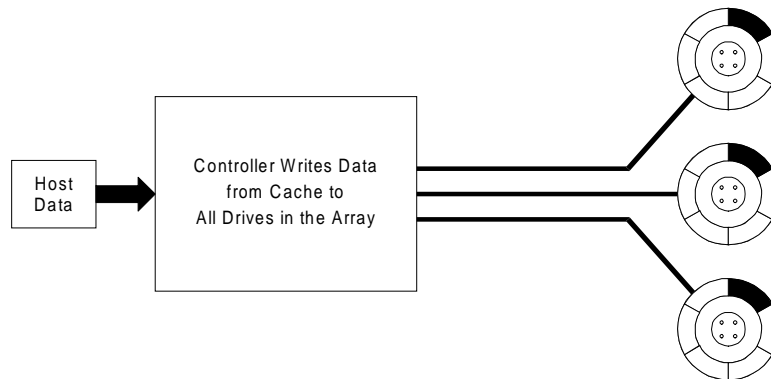

Figure 1-4: Diagram of a RAID 1 write

A RAID 1 array will show up on the monitor as “degraded” when at least one drive fails, even if two or more members of the redundancy group remain in good working order. As long as at least two working drives remain in the array, you may continue to run the array in degraded mode without putting your data in jeopardy.

1.4.3 RAID 0+1

As its name implies, RAID 0+1 combines RAID 0 (striping) with RAID 1 (mirroring). In a RAID 0+1 write, the controller breaks up the data block from the host into smaller chunks, then writes the chunks to half the drives in the array, while writing duplicate chunks to the remaining drives.

RAID 0+1 Write

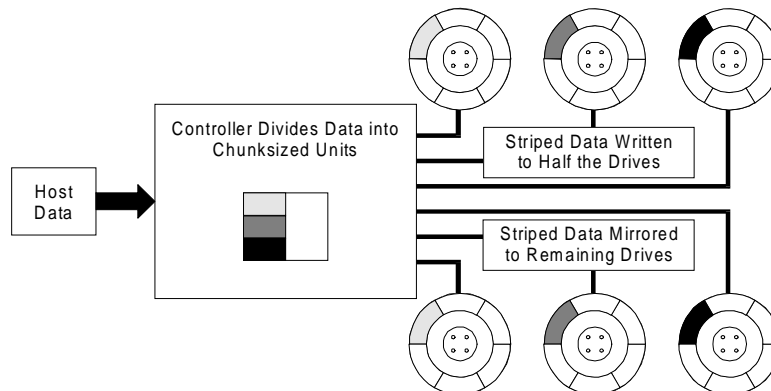

Figure 1-5: Diagram of a RAID 0+1 write

In the event of a drive failure, a RAID 0+1 array will enter degraded mode and continue to operate by substituting the failed drive with its mirror.

When the controller creates a RAID 0+1 set, it first sorts the drives by channel number and SCSI ID. Then it stripes the data across every other drive and forms a mirrored pair with the first two drives, another mirrored



pair with the second two drives, and so on. Table 1-1 describes how the controller uses the drives in a RAID 0+1 set.

Table 1-1: RAID 0+1 Example

Drives Selected	Function
Channel 1, ID 0	First member of stripe set
Channel 1, ID 1	Mirror of Channel 1, ID 0
Channel 1, ID 2	Second member of stripe set
Channel 2, ID 0	Mirror of Channel 1, ID 2
Channel 2, ID 1	Third member of stripe set
Channel 2, ID 2	Mirror of Channel 2, ID 1

1.4.4 RAID 4

RAID 4 breaks up host data into chunks, calculates parity by performing an exclusive-or on the chunks, and then writes the chunks to all but one drive in the array and the parity data to the last drive. When the host request data from the disk drives, the controller retrieves the chunks containing the addressed data, reconstitutes the data from the chunks, and passes the data to the host.

RAID 4 Write

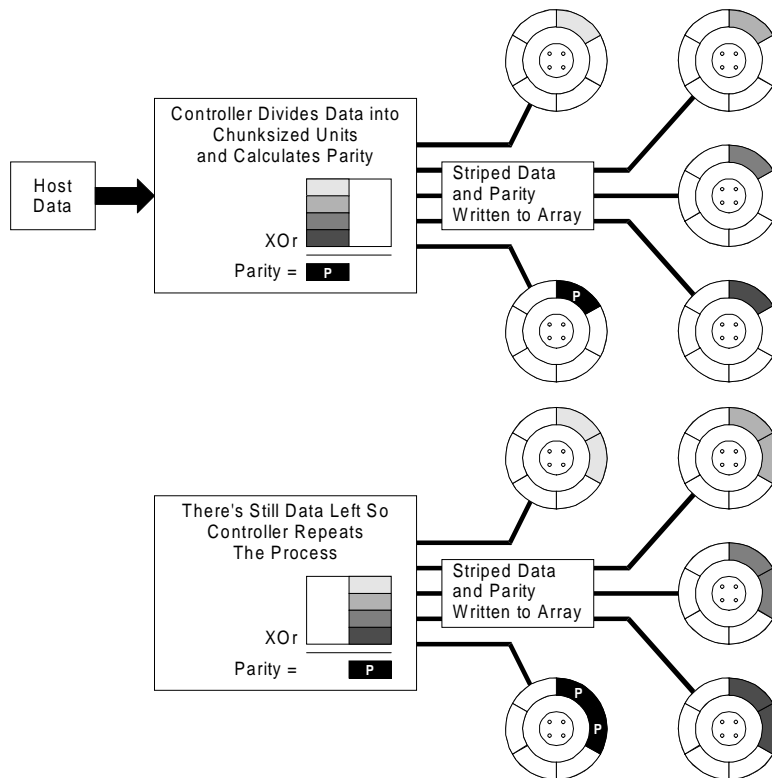

Figure 1-6: Diagram of a RAID 4 write



In the event of a single drive failure, a RAID 4 array will continue to operate in degraded mode. If the failed drive is a data drive, writes will continue as normal, except no data will be written to the failed drive. Reads will reconstruct the data on the failed drive by performing an exclusive-or operation on the remaining data in the stripe and the parity for that stripe. If the failed drive is a parity drive, writes will occur as normal, except no parity will be written. Reads will simply retrieve data from the data disks. There will be no deterioration in controller performance while a RAID set is in degraded mode.

In general, RAID 4 is best suited for applications such as graphics, imaging, or video that call for reading and writing huge, sequential blocks of data. However, you may find that RAID 4 is preferable to RAID 5 even for applications characterized by many small I/O operations, such as transaction processing. This is due to the CRD-5500's intelligent caching, which efficiently handles small I/O reads and writes, and to the relatively less complex algorithms needed to implement RAID 4.

The benefits of RAID 4 disappear when you have many, small I/O operations scattered randomly and widely across the disks in the array. RAID 4's fixed parity disk becomes a bottleneck in such applications, as the following example illustrates. Let's say the host instructs the controller to make two small writes. The writes are widely scattered, involving two different stripes and different disk drives. Ideally, you would like both writes to take place at the same time, but RAID 4 makes this impossible, since the writes must take turns accessing the fixed parity drive. For this reason, RAID 5 is the better choice for widely scattered, small write operations.

Warning

RAID 4 can withstand a single drive failure and handle I/O activity without interruption in degraded mode until the failed drive is rebuilt. If a second drive fails while the RAID set is in degraded mode, the entire RAID set will fail.

1.4.5 RAID 5

RAID 5 addresses the bottleneck issue for barrages of widely scattered, small I/O operations. Like RAID 4, RAID 5 breaks data up into chunks, calculates parity, and then writes the chunks in stripes to the disk drives, saving one drive on each stripe for the parity data. Unlike RAID 4, however, RAID 5 changes the parity drive on each stripe. This means, for instance, that a write operation involving drive 2 on stripe 1 can conceivably take place at the same time as a write involving drive 3 on stripe 2, since they would be addressing different parity drives.



RAID 5 Write

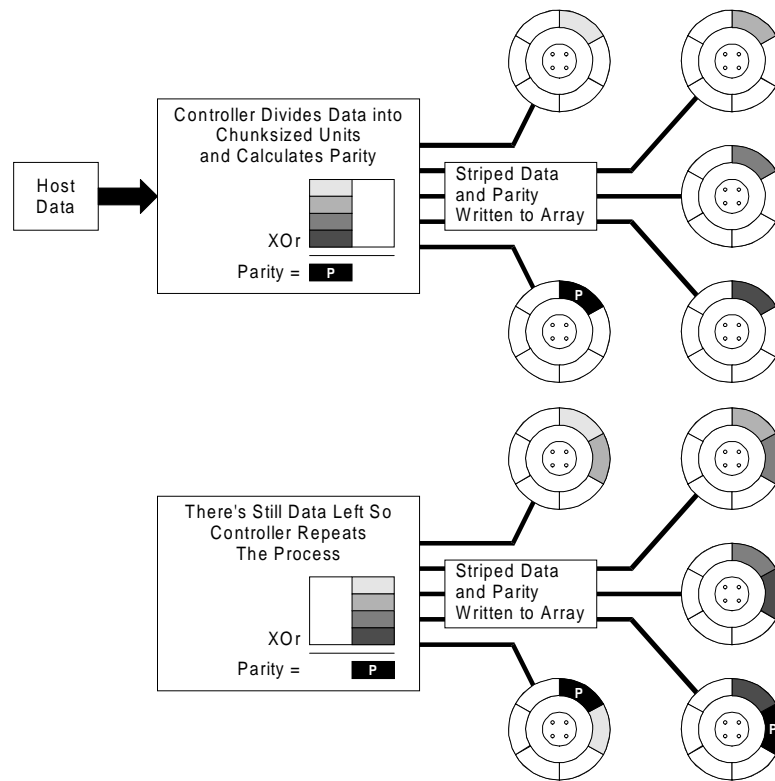

Figure 1-7: Diagram of a RAID 5 write

RAID 5 handles drive failures in the same manner as RAID 4, except the parity drive is different for each stripe. The controller either uses the parity information on a stripe to reconstruct its data or simply reads the data as normal, depending on location of the stripe's parity drive.

While RAID 5 is ideally suited for applications with many, small I/O operations, there is no reason why it cannot function equally well for applications with large, sequential I/O operations. This makes RAID 5 an excellent all-purpose RAID level.

Warning

RAID 5 can withstand a single drive failure and handle I/O activity without interruption in degraded mode until the failed drive is rebuilt. If a second drive fails while the RAID set is in degraded mode, the entire RAID set will fail.

1.4.6 JBOD

JBOD, which stands for "Just a Bunch of Disks," makes it possible to connect one or more standalone disk drives to the controller. A JBOD disk drive is not part of a redundancy group, even though the controller assigns a redundancy group number to the drive. This number becomes that logical unit number (LUN) that the host will use to address the drive. (You may map any redundancy group number to another LUN using the Host LUN Mapping feature of the monitor utility.)



One use for JBOD is to connect a system disk drive to the CRD-5500. The drive does not become part of a RAID set, but it is made available to the host on the same SCSI bus as the other devices controlled by the CRD-5500.

1.5 A Few Words About Compatibility

The CRD-5500 is designed to be compatible with the CRD-5000, an earlier RAID controller from CMD Technology. In most cases, CRD-5000 users should be able to run their existing RAID sets on the CRD-5500 without recreating them. A handful of restrictions apply to this backwards compatibility:

- The CRD-5500 does not support RAID 3 or RAID 0 with single-block chunk sizes. RAID sets created on the CRD-5000 with either of these configurations will not operate on the CRD-5500.
- Disk drives connected to the CRD-5500 must support “read long” and “write long.” Most SCSI disk drives meet this criterion, but you should check the specifications for your older drives.
- The CRD-5500 uses high-density connectors on all its I/O modules. You may need to replace some or all of the cables from your CRD-5000 system.
- You will not be able to use the memory modules from your old controller. The CRD-5500 requires 72-pin, 36-bit, 60-nanosecond SIMMs. The CRD-5000 uses 30-pin, 9-bit, 80-nanosecond SIMMs.

Note

Users of the CRD-5000 will have to modify their concept of creating RAID sets. The CRD-5500 does not have “ranks.” RAID sets may comprise any combination of disk drives, regardless of their I/O channel or SCSI ID. In addition, the CRD-5500 defines each RAID set or partition of a RAID set as a “redundancy group.” These redundancy groups may be mapped to host LUNs, either in a direct one-to-one relationship or in a manner defined by the user.



This page left blank intentionally.

2 Setup Guidelines

2.1 Installing Modules

The CRD-5500's modular design offers great flexibility in configuring the controller. All controllers come with a system board. The rest of the slots are I/O channels, either for I/O to and from the host computer or to and from the disk drives connected to the controller. Each slot may take an 8-bit single-ended module, a 16-bit single-ended module, or a 16-bit differential module. Any module installed in I/O slot 0, located next to the system board, will be recognized by the controller as a host channel module. Modules installed in slots 1, 2, and 3 may be configured as host or disk channel modules. And modules installed in slots 4 through 8 will be recognized by the controller as disk channel modules. Figure 2-1 shows a configuration with one 16-bit single-ended module in slot 0, and five 8-bit single-ended modules in slots 2 through 6 for the disk channels.

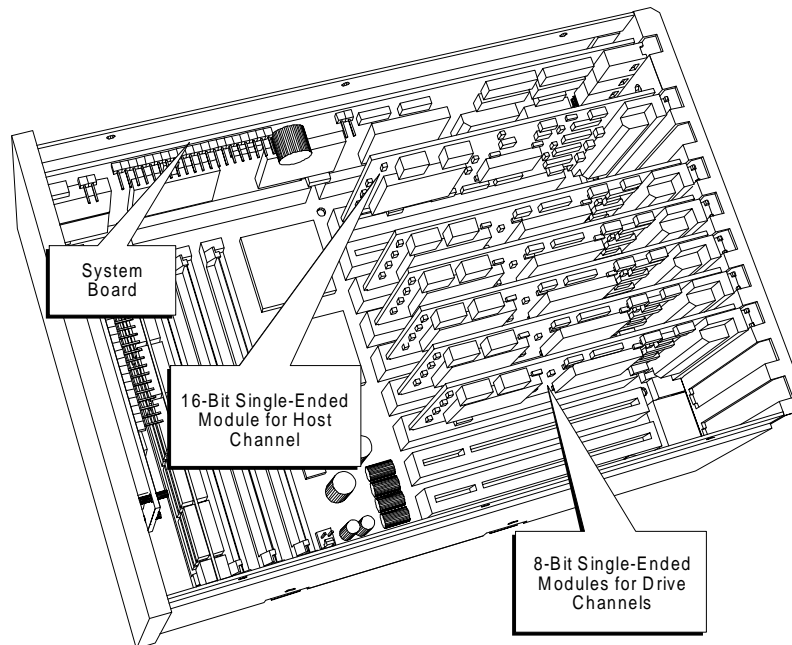

Figure 2-1: Location of modules

2.1.1 How To Tell the Modules Apart

The CRD-5500 I/O modules may be used for host or drive channels. The 8-bit, 16-bit, and differential modules share the same form factor and connector. They are indistinguishable once installed. To tell them apart you must either inspect the components on the modules or read the part number imprinted on the back of the module. The following table gives the part numbers for the CRD-5500's I/O modules.



Part Number	Module
CRD-5530	8-bit, single-ended I/O card
CRD-5540	16-bit, single-ended I/O card
CRD-5560	16-bit, differential I/O card

The differences between the 8-bit/single-ended, 16-bit/single-ended, and 16-bit/differential modules are subtle. Figs. 2-2, 2-3, and 2-4 show diagrams of the modules. The key components that highlight their differences are shaded.

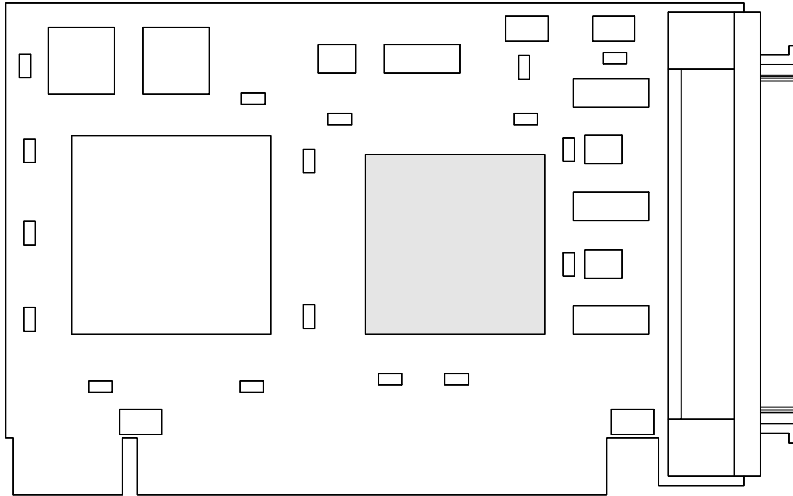

Figure 2-2: CRD-5530 8-bit single-ended I/O module

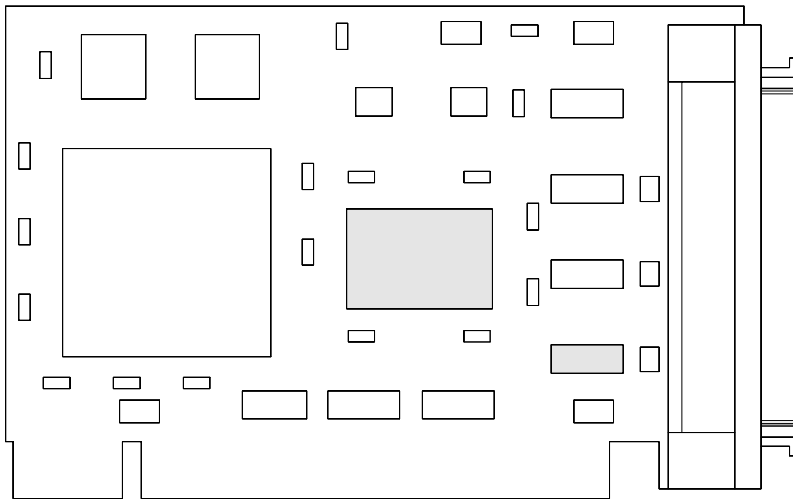

Figure 2-3: CRD-5540 16-bit, single-ended I/O module

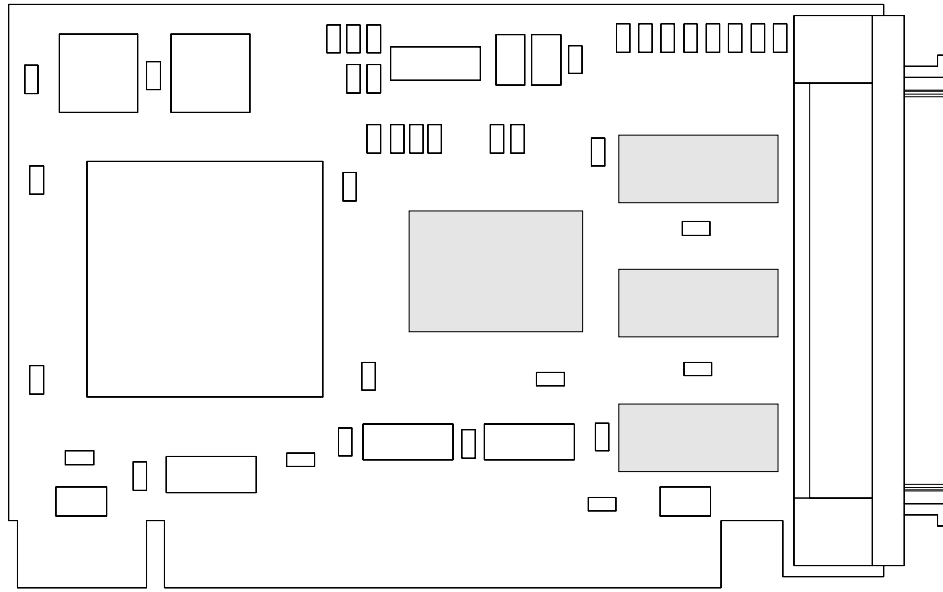

Figure 2-4: CRD-5560 16-bit, differential I/O module

2.2 Disk Drives

The CRD-5500 is designed to accept Fast SCSI disk drives (or Fast “Wide” disk drives if you use the 16-bit I/O module) from any manufacturer. You may mix drives of different makes and models in the same RAID set. You may even combine disk drives of different sizes in the same RAID set. If you do this, however, the CRD-5500 will use only a portion of the larger drives. For example, if you combine a 1 gigabyte drive with two 1.2 gigabyte drives, the CRD-5500 will treat the RAID set as if it comprised three 1 gigabyte drives.

The CRD-5500 supports up to seven disk drives per disk channel. This limitation applies to both 16-bit I/O modules as well as the 8-bit module. Even though you can not use the upper 8 addresses on the 16-bit buses, you will benefit from the doubled bandwidth.

Note

The CRD-5500's only requirement for SCSI disk drives is that they must support “read long” and “write long.” Most SCSI disk drives meet this criterion, but you should check the specifications of any older drives.

2.2.1 Drive Geometry

Although a RAID set on the CRD-5500 appears as one drive to the host, it is in fact a logical representation of several disk drives. This means that the traditional vocabulary for describing a disk drive's geometry—sectors, heads, and cylinders—has no meaning in the RAID environment. However, for the benefit of operating systems, such as UNIX, that require disk geometry information, the CRD-5500 reports the following values for sectors, heads, and cylinders.



	RAID Sets 32 GB and Under	RAID Sets over 32 GB
Sectors	64	128
Heads	16	128
Cylinders	Divide the total number of blocks in the RAID set by 1024 and drop the remainder.	Divide the total number of blocks in the RAID set by 16384 and drop the remainder.

The sector and head values are constant, while the cylinder value varies according to the size of the RAID set. As the above table shows, the CRD-5500 also uses two different methods for reporting drive geometry: one for RAID sets with capacities of 32 gigabytes and under, and another method for RAID sets over 32 gigabytes.

2.2.1.1 Drive Geometry Example

This section shows how to determine the disk geometry that the CRD-5500 will report for a sample RAID set. This RAID set is shown in the following *RAID Set Information* screen from the controller's monitor utility.

```

Monitor Utility                                02-21-96
RAID SET INFORMATION                          10:14:38
  
```

RAID Set Number	1	RAID Level	5
RAID Set Status	Non-Degraded	Partitions	1
Date Stamp	02-21-96 10:17:45	Redundancy Grps	1
Redundancy Grp	1	Chunk Size	256
Capacity	4134 MB	Capacity	8466432 BLKS

#	I/O Ch	SCSI ID	Member Status	Member Size	Member Vendor	Member Model	Mbr Rev.
0	4	1	Online	1033 MB	FUJITSU	M2694ES-512	811F
1	4	3	Online	2050 MB	QUANTUM	XP32150	581H
2	7	1	Online	1033 MB	FUJITSU	M2694ES-512	811F
3	6	1	Online	2040 MB	SEAGATE	ST12550N	0013
4	6	2	Online	2050 MB	QUANTUM	XP32150	581H

N: NEXT | P: PREV | CTRL-Z: EXIT

Since the RAID set is less than 32 gigabytes, the number of sectors will be 64, and the number of heads will be 16. To determine the number of cylinders, take the capacity of the RAID set in blocks from the top, right portion of the screen, divide that value by 1024 and toss the remainder. In this example, the block capacity is 8466432. Therefore, the number of cylinders the CRD-5500 will report for this RAID set would be 8268 ($8466432 \div 1024 = 8268$).

2.3 SCSI Bus Setup

The CRD-5500 involves several SCSI buses, which can take the form of 8-bit single-ended, 16-bit single-ended, or 16-bit differential buses. On top of this, one or more of the buses may be designated as a host bus for communicating with the host computer, and the others may be populated with disk drives to form the RAID set pool. Each SCSI bus must be terminated at both ends, and each device on the bus, including the host adapter and the CRD-5500 itself in the case of a host bus, must have a unique SCSI ID.

Host Channel Buses: To set the SCSI ID and activate or deactivate termination on a host bus, you must use the controller's onboard configuration utility. The settings for these parameters and others are grouped in the *Host Parameters* screen. See page 4-3 for a description of this screen. For 16-bit "Wide" modules, you may select full, partial or no termination. Full termination acts on all 16 of the bus's data lines. Partial termination acts on the upper 8 data lines only and is useful when you mix 8-bit and 16-bit devices on



the same bus. The CRD-5500 always supplies power to the terminator resistors. There is no harm in having more than one device on the bus supply terminator power.

Disk Channel Buses: When an I/O module assumes the role of a disk channel module, either by virtue of its location in slots 4 through 8 or by user intervention in slots 1 through 3, it always takes SCSI ID 7 and terminates one end of the bus. All drives connected to the module should have unique SCSI IDs that do not conflict with the module's ID or the IDs of the other drives on the bus. If you are using a 16-bit I/O module, you may connect only 7 drives to the module, and SCSI IDs of the drives must be less than 7. Each disk channel bus must be terminated at the opposite end, either by activating the terminators on the last disk drive, or better yet by installing a terminator at the end of the cable or on the back plane.

If you have purchased a turnkey RAID system, the configuration of the disk channel buses likely will have been done for you, leaving only the host bus or buses to be configured for your particular system.

2.4 Cache

The CRD-5500's cache accepts as many as four standard SIMMs for up to 512 megabytes of read and write memory.

Note

The CRD-5500 will not operate without at least one SIMM installed in the cache.

2.4.1 How To Order SIMMs

When you purchase SIMMs, they should meet the following specifications:

Speed	60 nanoseconds
Bus Width	36 bits wide
Refresh Rate	2 ms
Pins	72
Capacity	4 to 128 megabytes
IC Count	Not more than 36
Parity	"True" Parity

Note

The CRD-5500 does not support SIMMs with more than 36 integrated DRAM circuits (ICs) on board. Check your larger SIMMs, in particular any 128 MB SIMMs, to make sure they don't carry more than 36 ICs. The CRD-5500's self-test will reject SIMMs that do not support "true" parity. These SIMMs do not store parity. Instead, they calculate parity on the fly for each read and write from cache, report the result to the initiator, and then discard the value.

The capacity of 36-bit-wide SIMMs may not be apparent from the listings in merchandise catalogs. Use the following table as a guide:



Configuration	Size	Configuration	Size
1 x 36	4 megabytes	8 x 36	32 megabytes
2 x 36	8 megabytes	16 x 36	64 megabytes
4 x 36	16 megabytes	32 x 36	128 megabytes

2.4.2 Installing SIMMs

The CRD-5500 requires that at least one SIMM be installed in slot 0, located nearest the front of the box. Install additional SIMMs starting from slot 1 and work your way towards the back of the box. Figure 2-5 shows how to install SIMMs in the CRD-5500.

Warning

Be sure to remove all power (including battery power) to the controller before installing SIMMs. Observe all standard anti-ESD shop practices before you touch a SIMM.

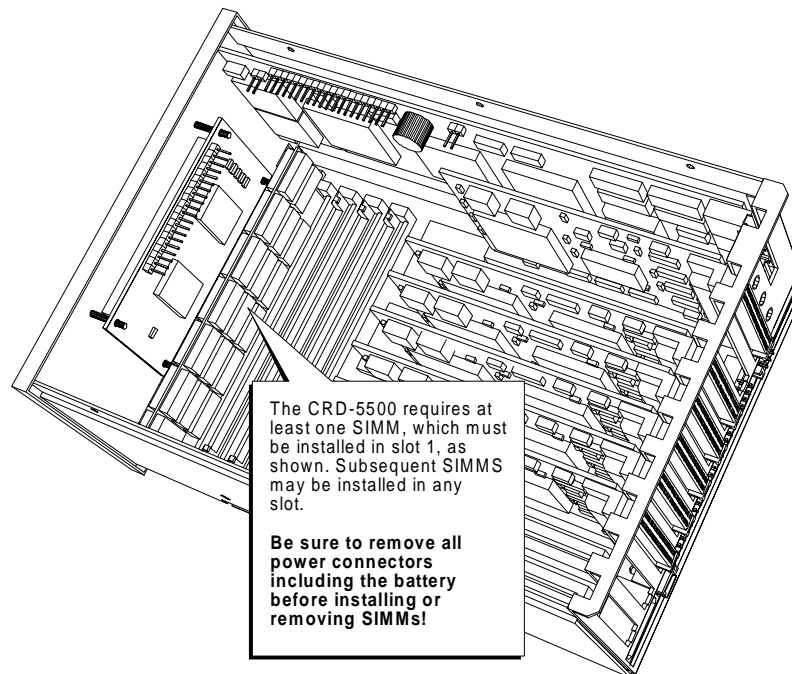

Figure 2-5: Installing SIMMs

2.5 Warning Alarm

A two-level temperature sensor monitors any heat build-up inside the CRD-5500. When the temperature reaches approximately 105° Fahrenheit, the alarm will sound every two seconds. In such an event, you should take immediate steps to cool the unit or shut the system down in an orderly fashion. If the temperature climbs to approximately 120°, the alarm will sound twice a second. The CRD-5500 will complete any pending I/O activity and then accept no more instructions from the host.



The alarm also sounds when the system voltage drops below 4.80 volts or climbs above 5.25 volts, or the termination power voltage drops to 4.75 volts or climbs to 5.30 volts.

You may silence the alarm by pressing Ctrl-x on the monitor keyboard or by simultaneously pressing the up and down arrow buttons on the front panel.

2.6 Battery Backup

You may connect a battery or uninterruptible power supply (UPS) to the CRD-5500 to protect data in the controller's cache in the event of a power failure. To improve performance, the CRD-5500 stores write data in its cache. It tells the host that the data has been written to disk but actually completes the write later. If the power supply is interrupted during the interval between the CRD-5500's acknowledgment to the host and the actual write, the data in the cache will be lost. A backup power source can prevent this loss of data, by protecting data while the controller holds it in volatile memory.

Note

It is strongly recommended that you connect an uninterruptible power supply or backup battery to the CRD-5500. Otherwise, data held in the controller's cache will be vulnerable to power interruptions.

The CRD-5500 is designed to accept a 6.6 volt DC, lead-acid, gell-pack backup battery with a capacity in the range of 4 to 34 amp hours.

If you have a UPS, you may connect the AC power fail and low battery signal lines to the CRD-5500.

Figure 2-6 identifies the connectors on the back panel.

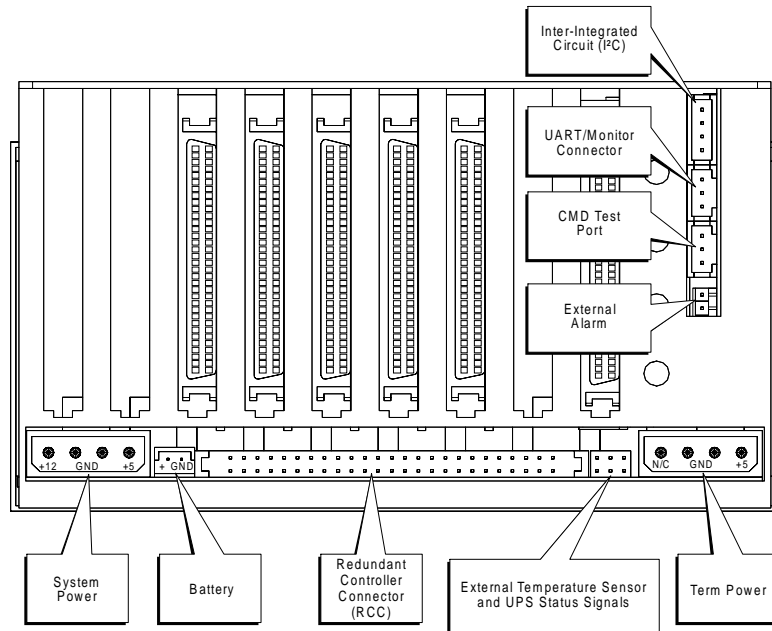

Figure 2-6: Back panel connectors

2.7 Fan

The fan built in to the CRD-5500's top cover plate gets its power from a connector on the motherboard. Should this connection be broken, which can happen easily when you remove the cover to service the inside of the box, reconnect the fan cable to the connector shown in Figure 2-7. The connector is polarized to ensure correct installation.

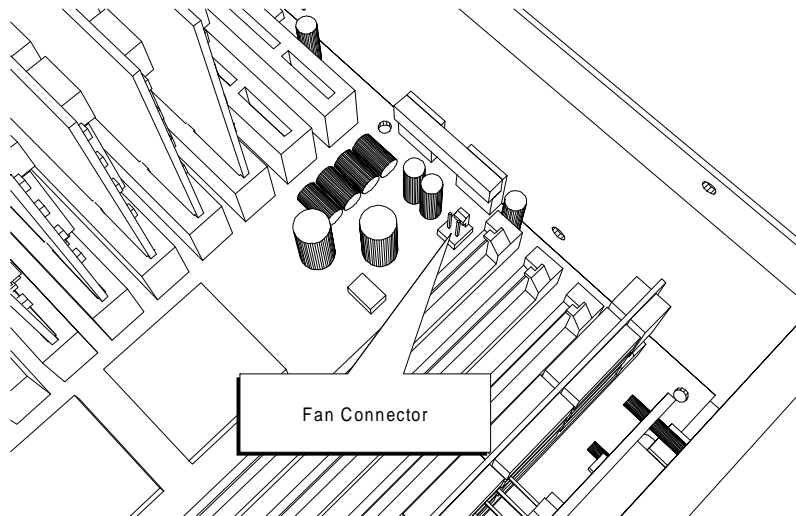

Figure 2-7: Location of fan connector



2.8 Connecting to a Monitor

The CRD-5500 contains a monitor utility that is accessible through the UART/Monitor connector on the back of the controller box. If the your CRD-5500 is part of an enclosure, there is probably a serial cable connector on the exterior of the box.

To use the monitor utility, connect a serial cable from the enclosure to a terminal or a computer equipped with terminal emulation software. Set your terminal communications parameters as follows:

- 9600 baud
- 8 data bits, 1 stop bit, no parity
- Xon/Xoff flow control

2.8.1 Using the Terminal Program in Microsoft Windows

You may connect the serial cable to a PC or laptop and access the monitor utility through a communications application such as the Terminal program in Microsoft Windows. Here is how to set up Terminal to run the monitor utility.

Activate the Terminal application, and select Terminal Emulation... from the Settings menu. Choose DEC VT-100 (ANSI).

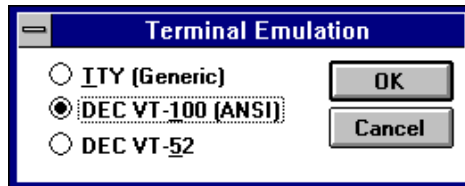

Select Terminal Preferences... from the Settings menu. Make sure that the "Use Function, Arrow, and Ctrl Keys for Windows" box is not selected.

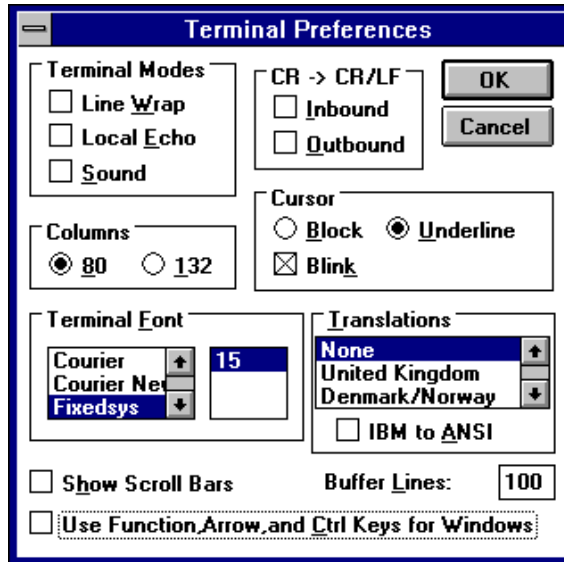

Finally, select Communications... from the Settings menu. Set the baud rate to 9600, data bits to 8, stop bits to 1, parity to none, and flow control to Xon/Xoff.

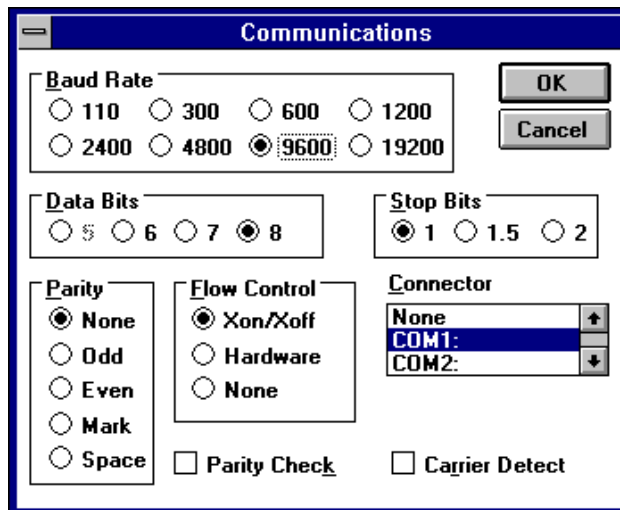



This page left blank intentionally.



3 Configuration Example

This chapter offers an example of the steps necessary to configure a controller for the first time and create a RAID set. In this example, we will configure a controller with two 16-bit host channels and six 8-bit disk channels.

3.1 Connecting the Drives

Our system will have four disk drives on each of the controller's six disk channels, for a total of 24 disk drives. To connect the drives, run a shielded SCSI cable from each of the controller's drive channels, and daisy-chain the drives to each cable. In this example, the drives are distributed evenly across all six drive channels. (Note that such a distribution is desirable for balancing traffic on the SCSI buses but is not *required*, since the CRD-5500 can form RAID sets using drives from any channel and SCSI ID.)

Make sure that you set each drive to a unique ID on its SCSI bus. Each CRD-5500 drive channel is set to a SCSI ID of 7. The drives on each channel, therefore, may be set to any available SCSI ID from 0 to 6.

The CRD-5500's drive channels automatically terminate their end of the SCSI bus. You must see that the other end of the bus is terminated. This may be done by enabling termination on the last drive on the bus or, better yet, by installing an external terminator to the end of the SCSI cable.

3.2 Setting Up the Host Interface

In this example, we will configure the 16-bit I/O channels in slots 0 and 1 as host modules. Connect the host SCSI cables to these modules. Power on the controller and enter the monitor utility. At the main menu, select *Setup Parameters*.

```
Monitor Utility                                02-05-96
MAIN MENU                                     18:09:30

+-----+
| RAID Set Information |
| Setup Parameters    |
| System Information  |
| RAID Set Functions  |
| System Functions    |
| Disk Utilities      |
| Rebuild/Create Status |
| Event Log           |
+-----+
```

UP ARROW: CURSOR UP | DOWN ARROW: CURSOR DOWN | ENTER: SELECT | CTRL-Z: EXIT

At the next menu, select *Channel Settings*. This is where we will configure the I/O module in slot 1 as a host module. Use the arrow keys to navigate to the Module Type cell for Channel 1. Press Enter to edit the field. Use the keyboard arrow keys to toggle the field to "HOST." Press Enter to save the selection and Ctrl-Z to exit the *Channel Settings* screen.



Monitor Utility 02-09-96
CHANNEL SETTINGS 13:20:49

Channel	Module Type	Module Description
0	HOST	16-Bit Single-Ended
1	HOST	16-Bit Single-Ended
2	DISK	8-Bit Single-Ended
3	DISK	8-Bit Single-Ended
4	DISK	8-Bit Single-Ended
5	DISK	8-Bit Single-Ended
6	DISK	8-Bit Single-Ended
7	DISK	8-Bit Single-Ended

UP ARROW: CURSOR UP | DOWN ARROW: CURSOR DOWN | ENTER: SELECT | CTRL-Z: EXIT

Note

After you change the channel setting, you must restart the controller for the firmware to recognize the change. To restart the controller, select *Restart System* from the *System Functions* menu.

After you have set channel 1 to host mode and restarted the controller, select *Host Parameters* from the *Setup Parameters* menu.

Monitor Utility 02-09-96
MAIN MENU 13:25:45

RAID Set Information
Setup Parameters
Syst+ Host Parameters
RAID System Parameters
Syst Host LUN Mapping
Disk Channel Settings
Rebu
Even+

UP ARROW: CURSOR UP | DOWN ARROW: CURSOR DOWN | ENTER: SELECT | CTRL-Z: EXIT

We will configure each host channel for a Wide SCSI host bus, which will be terminated with external terminator resistors. Let's say that SCSI ID 0 is not being used by any other device on the bus, so we will use this ID for the CRD-5500. Since we are working with a high-performance host adapter, we will enable tag queuing, and set the synchronous transfer rate as high as it will go.

Given these conditions, we will complete the *Host Parameters* screen as follows:

Monitor Utility 07-05-95
HOST PARAMETERS 18:10:08

Parameter	Channel 0	Channel 1
SCSI ID	0	0
Tag Queuing	ON	ON
Sync. Mode	ON	ON
Sync. Rate	20 MB/SEC	20 MB/SEC
Bus Width	16 Bit	16 Bit
Termination	OFF	OFF

ARROW KEYS: MOVE CURSOR | ENTER: SELECT | CTRL-Z: EXIT |

To make the most of the Wide SCSI bus, we will turn *Sync. Mode* on, set the *Bus Width* to 16 Bit, and enter 20 MB/sec. for the *Sync. Rate*. Since the bus will be terminated with external terminators, we can safely turn off the host module's termination.

Once you have set the host parameters to your satisfaction, exit the *Host Parameters* screen by pressing Ctrl-Z.

Note

When you make changes to the host parameters, you must restart the controller for the changes to take effect. Select *Restart System* from the *System Functions* menu.



3.3 Creating a RAID Set

The CRD-5500 affords great flexibility in creating RAID sets. Drives of different sizes and manufacturers may be combined in a RAID set (although the size of the RAID set will be limited by the lowest common denominator represented by smallest drive). The controller supports RAID levels 0, 0+1, 1, 4, 5, and JBOD. A RAID set may be partitioned into as many as 16 units. RAID sets may include any drive connected to the controller, regardless of the drive's disk channel or SCSI ID. You may also designate hot or warm spares. The spares are global, meaning that they are available for use by any RAID set.

In this example, we will create a single-partition Level 4 RAID set with five of the drives connected to the controller. The steps outlined in this example may be repeated with appropriate modifications to create additional RAID sets with the other drives.

3.3.1 How To Create a RAID Set

To create a RAID set, follow these steps.

- 1 Select *RAID Set Functions* from the monitor utility main menu.

```

Monitor Utility                                07-05-95
MAIN MENU                                     18:09:30

+-----+
| RAID Set Information |
| Setup Parameters    |
| System Information  |
| RAID Set Functions  |
| System Functions    |
| Disk Utilities      |
| Rebuild+Create Status |
| Event Log           |
+-----+

UP ARROW: CURSOR UP | DOWN ARROW: CURSOR DOWN | ENTER: SELECT | CTRL-Z: EXIT

```

- 2 Select *Create RAID Set* from the submenu.

```

Monitor Utility                                07-05-95
MAIN MENU                                     18:10:59

+-----+
| RAID Set Information |
| Setup Parameters    |
| System Information  |
| RAID Set Functions  |
| System+-----+
| Disk U | Create RAID Set |
| Rebuil | Rebuild Disk   |
| Event  | Add Spares     |
+-----+

UP ARROW: CURSOR UP | DOWN ARROW: CURSOR DOWN | ENTER: SELECT | CTRL-Z: EXIT

```

Drives that are not part of a RAID set will show up as *Unkn* (Unknown). After a drive becomes part of a RAID set, its *RAID Set* number will appear in the Channel-ID cell.

```

Monitor Utility                                02-09-96
CREATE RAID SET                               14:30:22

+-----+ +-----+ +-----+
| RAID Set | 0 | | RAID Level | 4 | | Partitions | 1 |
+-----+ +-----+ +-----+

Ch 3   Ch 4   Ch 5   Ch 6   Ch 7   Ch 8
----
Id 0 | Unkn | Unkn | Unkn | Unkn | Unkn | Unkn |
+-----+ +-----+ +-----+ +-----+ +-----+ +-----+
Id 1 | Unkn | Unkn | Unkn | Unkn | Unkn | Unkn |
+-----+ +-----+ +-----+ +-----+ +-----+ +-----+
Id 2 | Unkn | Unkn | Unkn | Unkn | Unkn | Unkn |
+-----+ +-----+ +-----+ +-----+ +-----+ +-----+
Id 3 | Unkn | Unkn | Unkn | Unkn | Unkn | Unkn |
+-----+ +-----+ +-----+ +-----+ +-----+ +-----+
Id 4 |  |  |  |  |  |  |
+-----+ +-----+ +-----+ +-----+ +-----+ +-----+
Id 5 |  |  |  |  |  |  |
+-----+ +-----+ +-----+ +-----+ +-----+ +-----+
Id 6 |  |  |  |  |  |  |
+-----+ +-----+ +-----+ +-----+ +-----+ +-----+

ENTER: SELECT | C: CONTINUE | I: DRIVE INFO | CTRL-Z: EXIT

```

- 3 Select a *RAID Set* number, *RAID Level*, and the drives to include in the RAID set.



Use the arrow keys to navigate from field to field on the screen. When you reach a field that you wish to modify, press Enter and then use the up and down arrow keys to spin through the available options. When you arrive at the value you wish to keep, press Enter to save the selection. To cancel, press *Ctrl-Z*.

To create a new RAID set, first select a *RAID Set* number. As you spin through the numbers in the *RAID Set* cell, the controller will skip over numbers that already have been assigned. If you wish to select a RAID Set number that is assigned already, you first must destroy the RAID set with that number. This is done by setting two or more of its drives to *Unkn* (Unknown).

To select a drive for inclusion in the RAID set, set its Channel-ID field to *Onli* (Online). If you select a drive that already is part of a RAID set, the controller will inform you if you are about to cause the existing RAID set to be degraded or go offline and ask for confirmation.

This example shows the selection of the drives on ID 0 of the six drive channels.

Note

The CRD-5500 does not require the creation of RAID sets on ranks with identical IDs. You may select any available drive on any channel and any ID for inclusion in a RAID set.

```

Monitor Utility                                02-09-96
CREATE RAID SET                                14:31:06
-----+-----+-----+-----+-----+-----+
| RAID Set | 0 | | RAID Level | 4 | | Partitions | 1 |
+-----+-----+-----+-----+-----+-----+
      Ch 3   Ch 4   Ch 5   Ch 6   Ch 7   Ch 8
Id 0 | Onli | | Onli | | Onli | | Onli | | Onli | | Onli |
-----+-----+-----+-----+-----+-----+
Id 1 | Unkn | | Unkn | | Unkn | | Unkn | | Unkn | | Unkn |
-----+-----+-----+-----+-----+-----+
Id 2 | Unkn | | Unkn | | Unkn | | Unkn | | Unkn | | Unkn |
-----+-----+-----+-----+-----+-----+
Id 3 | Unkn | | Unkn | | Unkn | | Unkn | | Unkn | | Unkn |
-----+-----+-----+-----+-----+-----+
Id 4 |  | |  | |  | |  | |  | |  |
-----+-----+-----+-----+-----+-----+
Id 5 |  | |  | |  | |  | |  | |  |
-----+-----+-----+-----+-----+-----+
Id 6 |  | |  | |  | |  | |  | |  |
-----+-----+-----+-----+-----+-----+
ENTER: SELECT | C: CONTINUE | I: DRIVE INFO | CTRL-Z: EXIT
    
```

- 4 Once you have made your selections, press *C* to continue to the next step in the creation process.
- 5 Designate a *Redundancy Group* number and *Chunk Size*. The *Redundancy Group* number will translate to the logical unit number (LUN) that the host will use to address the RAID set. (You may map a redundancy group to a different LUN with the *Host LUN Mapping* screen.) The controller will skip over Redundancy Group numbers that already have been assigned. The chunk size determines how the data from the host will be apportioned across the drives in the RAID set. (See page 4-10 for help in selecting a chunk size.)

```

Monitor Utility                                02-19-96
CREATE RAID SET                                14:46:36
-----+-----+-----+-----+
| Partition | Redundancy | Chunk Size | Partition |
|           | Group      | (BLKS)    | Size (MB) |
+-----+-----+-----+-----+
| 0         | 0          | 256       | 1522      |
+-----+-----+-----+-----+
| Capacity (Used/Total) | 1522/1522 MB |
+-----+-----+-----+-----+
    
```

ENTER: SELECT | C: CREATE | CTRL-Z: PREVIOUS PAGE |

- 6 Press *C* again to initiate the creation process. You will be prompted to confirm the action. Press *Enter* to proceed.

You may view the progress of the RAID set creation by selecting *Rebuild/Create Status* from the main menu of the monitor utility.



3.3.2 Creating a RAID Set with Multiple Partitions

To create a RAID set with multiple partitions, select *RAID Set Functions* and then *Create RAID Set* from the main menu. You will see a screen similar to the one below. (Since we previously created a Level 4 RAID set, using the drives on ID 0 of each channel, the fields for those drives will show 0, indicating that they are part of RAID Set 0.)

```

Monitor Utility                                02-09-96
CREATE RAID SET                                14:31:06

+-----+-----+-----+-----+-----+-----+
| RAID Set | 1 | | RAID Level | 4 | | Partitions | 1 |
+-----+-----+-----+-----+-----+-----+

   Ch 3   Ch 4   Ch 5   Ch 6   Ch 7   Ch 8
Id 0 | 0 | | 0 | | 0 | | 0 | | 0 | | 0 |
Id 1 | Unkn | | Unkn | | Unkn | | Unkn | | Unkn | | Unkn |
Id 2 | Unkn | | Unkn | | Unkn | | Unkn | | Unkn | | Unkn |
Id 3 | Unkn | | Unkn | | Unkn | | Unkn | | Unkn | | Unkn |
Id 4 | | | | | | | | | | | |
Id 5 | | | | | | | | | | | |
Id 6 | | | | | | | | | | | |

ENTER: SELECT | C: CREATE | I: DRIVE INFO | CTRL-Z: EXIT

```

Now follow these steps to create a partitioned RAID set.

- 1 Select a *RAID Set* number, *RAID Level*, *Partitions* value, and the drives you wish to include in the RAID set. This time we will create a Level 5 RAID set, using the drives on Ch. 3/ID 1, Ch. 4/ID 2, Ch. 5/ID 3, Ch. 6/ID 3, Ch. 7/ID 2, and Ch. 8/ID 1. In addition, we will designate the RAID set as RAID set number 1. And finally, we will split the RAID set into four partitions.

```

Monitor Utility                                02-09-96
CREATE RAID SET                                14:31:06

+-----+-----+-----+-----+-----+-----+
| RAID Set | 1 | | RAID Level | 5 | | Partitions | 4 |
+-----+-----+-----+-----+-----+

   Ch 3   Ch 4   Ch 5   Ch 6   Ch 7   Ch 8
Id 0 | 0 | | 0 | | 0 | | 0 | | 0 | | 0 |
Id 1 | Onli | | Unkn | | Unkn | | Unkn | | Unkn | | Onli |
Id 2 | Unkn | | Onli | | Unkn | | Unkn | | Onli | | Unkn |
Id 3 | Unkn | | Unkn | | Onli | | Onli | | Unkn | | Unkn |
Id 4 | | | | | | | | | | | |
Id 5 | | | | | | | | | | | |
Id 6 | | | | | | | | | | | |

ENTER: SELECT | C: CREATE | I: DRIVE INFO | CTRL-Z: EXIT

```

- 2 Once the drives are selected and the parameters entered, press *C* to begin the creation.
- 3 Designate a *Redundancy Group* number, *Chunk Size*, and *Partition Size* for each partition.

```

Monitor Utility                                02-19-96
CREATE RAID SET                                14:46:36

+-----+-----+-----+-----+
| Partition | Redundancy Group | Chunk Size (BLKS) | Partition Size (MB) |
+-----+-----+-----+-----+
| 0 | 1 | 256 | 381 |
| 1 | 2 | 256 | 381 |
| 2 | 3 | 256 | 381 |
| 3 | 4 | 256 | 381 |
+-----+-----+-----+-----+

+-----+-----+
| Capacity (Used/Total) | 1522/1522 MB |
+-----+-----+

ENTER: SELECT | C: CREATE | CTRL-Z: PREVIOUS PAGE |

```



Each partition must get a unique *Redundancy Group* number (the monitor utility enforces this by skipping over numbers already assigned). This number will be translated to the logical unit number (LUN) for the partition, unless you map the redundancy group to a different LUN with the *Host LUN Mapping* screen. Since each partition will appear to the host as a different disk drive, it must have its own LUN. In this example, *Redundancy Group* number 0 was assigned previously, so we will start the numbering at 1.

See page 4-10 for help on selecting a chunk size.

By default, the controller will apportion the available disk capacity equally among the partitions. You may adjust the partition size for each partition, if you wish. To change the size of a partition, use the arrow keys to highlight the partition size cell for each partition, and enter the new size in megabytes. As you enter new values, the Capacity (Used) field will be updated accordingly. If you enter a partition size that causes the total to exceed the available capacity, the Capacity (Used) field will contain a string of asterisks (****). You may use less than the total available capacity. The resulting redundancy groups will use only the amount of disk space that you specify.

Note how the concept of the *RAID Set Number* differs from the *Redundancy Group Number*. In this example, Redundancy Group numbers 1 through 4 are associated with RAID Set number 1. From the controller's point of view in this example, Redundancy Group number 0 belongs to RAID Set 0, which is configured for RAID Level 4, and Redundancy Group numbers 1 through 4 belong to RAID Set 1, which is configured for Level 5. From the host's point of view, there is no such thing as RAID Sets 0 and 1, only (in this example) LUNs 0 through 4, which the CRD-5500 sees as Redundancy Groups 0 through 4.

4 Press C to initiate the creation. You will be prompted to confirm the action. Press *Enter* to continue.

You may view the progress of the RAID set creation by selecting *Rebuild/Create Status* from the main menu of the monitor utility.

3.4 Designating Spare Drives

Use the *Add Spares* screen under the *RAID Set Functions* menu item to designate one or more disk drives as hot or warm spares.

```

Monitor Utility          02-09-96
ADD SPARES              14:30:22
-----
Ch 3  Ch 4  Ch 5  Ch 6  Ch 7  Ch 8
-----
Id 0  | 0 | | 0 | | 0 | | 0 | | 0 | | 0 |
-----
Id 1  | 1 | | Unkn | | Unkn | | Unkn | | Unkn | | 1 |
-----
Id 2  | Unkn | | 1 | | Unkn | | Unkn | | 1 | | Unkn |
-----
Id 3  | Unkn | | Unkn | | 1 | | 1 | | Unkn | | Unkn |
-----
Id 4  | | | | | | | | | | | | | |
-----
Id 5  | | | | | | | | | | | | | |
-----
Id 6  | | | | | | | | | | | | | |
-----
ENTER: SELECT | S: ADD SPARE | I: DRIVE INFO | CTRL-Z: EXIT
    
```

To designate a drive as a spare, use the arrow keys to highlight the field of an available drive and press *Enter*. A drive identified as *Unkn* (Unknown) is available for designation as a spare. A number in a drive field indicates that that drive is part of a RAID set. Once you have selected a drive field, use the up and down arrow keys to spin through the available options. Stop at *Hot* for a hot spare or *Warm* for a warm spare. Press *Enter* again to save your selection. Finally, press *S* to add the specified drives to your pool of spares.

Warm Spare: A drive that is connected to power but not spun up to reduce wear and tear while it stands by to take over for a failed drive.

Hot Spare: A drive that is connected to power and spun up to make it immediately available in case of a drive failure.

**Note**

Spares on the CRD-5500 are global. This means that they are available for use by all RAID sets. When the controller detects a drive failure it searches for the first available spare that is large enough to be a member of the degraded RAID set. The search progresses through each drive channel in ascending order.

You also may modify a drive designated as a spare. For instance, you could change a *Hot* spare to *Warm*, a *Warm* spare to *Hot*, or either type of spare to *Unkn* to remove it from the spare pool.

In this example, we will designate a couple of Hot spares and a couple of Warm spares, as follows.

```

Monitor Utility          02-09-96
ADD SPARES              14:30:22

   Ch 3   Ch 4   Ch 5   Ch 6   Ch 7   Ch 8
Id 0 | 0 | | 0 | | 0 | | 0 | | 0 | | 0 |
Id 1 | 1 | | Hot | | Warm | | Unkn | | Warm | | 1 |
Id 2 | Hot | | 1 | | Unkn | | Unkn | | 1 | | Unkn |
Id 3 | Unkn | | Unkn | | 1 | | 1 | | Unkn | | Unkn |
Id 4 | | | | | | | | | | | |
Id 5 | | | | | | | | | | | |
Id 6 | | | | | | | | | | | |

ENTER: SELECT | S: ADD SPARE | I: DRIVE INFO | CTRL-Z: EXIT

```

3.5 Rebuilding a Disk Drive

When a disk drive fails, the RAID set containing that drive will begin operating in degraded mode. This means that the RAID set will continue to handle I/O commands from the host, but there will be no redundancy to protect against additional drive failures. If another disk drive fails before the first drive is rebuilt, the data on the RAID set will be lost.

This makes it imperative that you immediately replace the bad disk drive and rebuild its data. If the controller can find a spare drive with enough capacity for the degraded RAID set, it will automatically begin a rebuild on the spare. If no adequate spares exist, it is up to you to replace the bad drive and initiate the rebuild. You need not install the replacement drive on the same SCSI ID as the failed disk. In fact, you could connect a new disk drive to any available drive channel and ID, rebuild the RAID set, and then remove the failed disk at a more convenient time.

Warning

When you set out to replace a bad disk drive, be sure that you are pulling the correct drive. If you mistakenly disconnect a working member of the degraded RAID set, you will cause a double-failure and shut down the RAID set. If you need assistance identifying the failed drive, check the Event Log and filter for Dropped Drives events. You will find an event description for the drive failure, including the drive channel and SCSI ID of the drive.

Once you have installed a new drive to replace the bad disk drive, initiate the rebuild by selecting *Rebuild Disk* from the *RAID Set Functions* menu.

If more than one degraded RAID set exists, use the arrow keys to display the RAID set you wish to rebuild. Press Enter to select that RAID set. Then work your way down with the arrow keys to the channel number and SCSI ID of the drive you wish to use as a substitute for the failed drive. Press Enter to edit that field. Press the arrow keys until the field shows *Rbld* for Rebuild. Press Enter to save the setting. Finally, press R to initiate the rebuild.



```

Monitor Utility                                02-09-96
REBUILD DISK                                  15:12:22

+-----+
| Degraded RAID Set To Rebuild | 1 |
+-----+

   Ch 3   Ch 4   Ch 5   Ch 6   Ch 7   Ch 8
Id 0 | 0 | | 0 | | 0 | | 0 | | 0 | | 0 |
Id 1 | 1 | | Hot | | Warm | | Unkn | | Warm | | 1 |
Id 2 | Hot | | 1 | | Unkn | | Rbld | | 1 | | Unkn |
Id 3 | Unkn | | Unkn | | 1 | | | | | Unkn | | Unkn |
Id 4 | | | | | | | | | | | | | |
Id 5 | | | | | | | | | | | | | |
Id 6 | | | | | | | | | | | | | |

ENTER: SELECT | R: REBUILD | I: DRIVE INFO | CTRL-Z: EXIT
    
```

The controller will ask you to confirm the action. Press Enter to proceed or Ctrl-Z to abort.

```

Monitor Utility                                02-09-96
REBUILD DISK                                  15:12:54

+-----+
| Degraded RAID Set To Rebuild | 1 |
+-----+

   Ch 3   Ch 4   Ch 5   Ch 6   Ch 7   Ch 8
Id 0 | 0 | | 0 | | 0 | | 0 | | 0 | | 0 |
Id 1 | 1 | | | | | | | | | | | | | 1 |
Id 2 | Hot | | | | | | | | | | | | | Unkn |
Id 3 | Unkn | | | | | | | | | | | | | Unkn |
Id 4 | | | | | | | | | | | | | |
Id 5 | | | | | | | | | | | | | |
Id 6 | | | | | | | | | | | | | |

ENTER: SELECT | CTRL-Z: EXIT
    
```

You may monitor the progress of the rebuild by selecting *Rebuild/Create Status* from the main monitor menu.

```

Monitor Utility                                02-19-96
REBUILD/CREATE STATUS                          15:15:21

+-----+
| 0 -----+
| Creating RAID Set 1                               Estimated Time: 00:07:23
| ##### 33%                                         Elapsed Time: 00:02:56
| 1 -----+
| Rebuilding Member 3 Of RAID Set 1                 Estimated Time: 00:04:16
| ##### 10%                                         Elapsed Time: 00:01:05
| 2 -----+
| Rebuild Completed For Member 2 Of RAID Set 2      Date Completed: 02-19-96
|                                                    Time Completed: 14:58:16
| 3 -----+
| 4 -----+
| 5 -----+
+-----+

CTRL-Z: EXIT
    
```

To speed up the rebuild, increase the *Rebuild Rate* under *Setup Parameters, System Parameters*. Decrease the rebuild rate if you want the controller to devote more resources to I/O activity.



4 Using the Monitor Utility

The CRD-5500's monitor utility provides complete control over the configuration and operation of the controller. You may also use the utility to view the status of the controller's RAID sets and monitor the progress of create and rebuild operations. An event log screen displays a continuously updated listing of controller events to aid in troubleshooting.

4.1 Navigating the Menu Tree

Each screen in the monitor utility contains a legend at the bottom screen with instructions for navigating that screen. The up and down arrows move among the fields or menu options on a screen. Use the Enter key to select a field or option. When you select a field, use the arrow keys to spin through the available values. Press *Enter* again to accept the displayed value. Press Ctrl-Z to exit the field without saving the change. You may also press Ctrl-Z to exit a screen and return to the next higher menu level.

The following outline shows the flow of the monitor utility menus.

RAID Set Information

Setup Parameters

- Host Parameter
- SCSI ID
- Tag Queuing
- Sync. Mode
- Sync. Rate
- Bus Width
- Termination

System Parameters

- Password Checking
- Date
- Time
- Rebuild Rate
- Create Rate
- UPS
- Read-Ahead
- Read-Ahead Limit
- Validation Delay
- Host LUN Mapping
- Channel Settings

System Information

- I/O Statistics
- Free Lists Statistics
- Manufacturing Information
- Environmental Status
- I/O Process Information

RAID Set Functions

- Create RAID Set
- Rebuild Disk
- Add Spares

System Functions

- Change Password
- Load System Code
- Restart System
- System Shutdown
- Download Drive Firmware

Disk Utilities

- Format Disk
- Test Disk

Rebuild/Create Status

Event Log

4.2 RAID Information

The *RAID Set Statistics* screen is the heart of the monitor utility and likely will be the screen you find most useful during normal operation of the controller. This screen provides a continuously updated report on the status of your RAID sets, with information about their parameters, drive configuration and condition.

The following is an example of a *RAID Set Statistics* screen.



Monitor Utility 02-21-96
RAID SET INFORMATION 10:14:38

RAID Set Number	1	RAID Level	5
RAID Set Status	Non-Degraded	Partitions	1
Date Stamp	02-21-96 10:17:45	Redundancy Grps	1
Redundancy Grp	1	Chunk Size	256
Capacity	4134 MB	Capacity	8466432 BLKS

#	I/O Ch	SCSI ID	Member Status	Member Size	Member Vendor	Member Model	Mbr Rev.
0	4	1	Online	1033 MB	FUJITSU	M2694ES-512	811F
1	4	3	Online	2050 MB	QUANTUM	XP32150	581H
2	7	1	Online	1033 MB	FUJITSU	M2694ES-512	811F
3	6	1	Online	2040 MB	SEAGATE	ST12550N	0013
4	6	2	Online	2050 MB	QUANTUM	XP32150	581H

N: NEXT | P: PREV | CTRL-Z: EXIT

Use the “N” and “P” keys to page through your RAID sets.

The CRD-5500 supports the partitioning of RAID sets. A partitioned RAID set will have multiple redundancy groups associated with it. Each redundancy group will have its own redundancy group number, which corresponds to the Logical Unit Number (LUN) that the host will use to address the partition, unless you map the redundancy group to another LUN with the Host LUN Mapping screen (see page 4-5). When you page to partitioned RAID set, the RAID Set Information will look like the following example.

Monitor Utility 02-21-96
RAID SET INFORMATION 10:14:38

RAID Set Number	2	RAID Level	5
RAID Set Status	Degraded	Partitions	2
Date Stamp	02-21-96 09:51:07	Redundancy Grps	2

#	I/O Ch	SCSI ID	Member Status	Member Size	Member Vendor	Member Model	Mbr Rev.
0	7	4	Online	1021 MB	DEC	DSP3107LS	440C
1	6	3	Rebuilding	1021 MB	DEC	DSP3107LS	440C
2	7	1	Online	1033 MB	FUJITSU	M2694ES-512	811F
3	6	1	Online	1021 MB	DEC	DSP3107LS	440C
4	6	2	Online	1021 MB	DEC	DSP3107LS	440C

N: NEXT | P: PREV | R: REDUNDANCY GRP INFO | CTRL-Z: EXIT

To view the information specific to each partition, press “R” for redundancy group information. The following is an example of the a redundancy group information screen.

Monitor Utility 02-21-96
RAID SET INFORMATION 10:14:38

Partition	Redundancy Grp	Chunk Size	Capacity (BLKS)	Capacity (MB)
0	2	256 BLKS	4182016	2042
1	3	256 BLKS	4182016	2042

CTRL-Z: PREVIOUS PAGE

4.3 Setup Parameters

This menu option uncovers the *Host Parameters*, *System Parameters*, *Host LUN Mapping*, and *Channel Settings* menu items. These screens are useful for configuring the controller.



4.3.1 Host Parameters

Use this screen to set the SCSI ID, Synchronous transfer rate, and termination for the CRD-5500 host modules. You may also enable or disable tag queuing here. The number of host channels depicted in the screen adjusts automatically according to the number of I/O modules you have configured as host channels.

```

Monitor Utility                                07-05-95
HOST PARAMETERS                               18:10:08
-----
Parameter | Channel 0 | Channel 1 |
-----
SCSI ID   | 0         | 0         |
Tag Queuing | ON        | ON        |
Sync. Mode | ON        | ON        |
Sync. Rate | 20 MB/SEC | 20 MB/SEC |
Bus Width  | 16 Bit    | 16 Bit    |
Termination | OFF       | OFF       |
-----

```

ARROW KEYS: MOVE CURSOR | ENTER: SELECT | CTRL-Z: EXIT |

SCSI ID: You must select a unique ID between 0 and 15 for a 16-bit host module, or between 0 and 7 for an 8-bit module. Make sure that the SCSI IDs for the other devices on the host bus, including the host adapter, do not conflict with the ID you set for the CRD-5500's host module.

Tag Queuing: If your host adapter supports tag queuing you may enable this feature. Tag queuing permits each initiator to issue commands accompanied by instructions for how the target should handle the command. The initiator can specify whether each command should be executed by the target at the first available opportunity, in the order in which it was received, or at a time deemed appropriate by the target. Tag queuing permits each initiator to have multiple commands outstanding and each target to optimize the commands it receives.

Sync. Mode: If you turn this parameter on, the controller will communicate at a synchronous transfer rate specified under Sync. Rate. To select asynchronous mode, turn Sync. Mode off.

Sync. Rate: Select the maximum synchronous transfer rate supported by the host adapter. An 8-bit module will support maximum sync. rates from five to 10 megabytes per second. The 16-bit module will support sync. rates up to 20 megabytes per second. This parameter applies only when the Sync. Mode parameter is turned on.

Bus Width: If you are using a 16-bit module, you should set this parameter to 16 Bit. Select 8 Bit if you are using an 8-bit module.

Termination: SCSI buses must be terminated at each end. With a 16-bit module, you may select full or partial termination, as well as no termination at all. If the host module is not at the end of the host SCSI bus, select no termination. If the host module is the last device on the bus, select full termination. Select partial termination if the host module is the last 16-bit device on the bus but additional 8-bit devices are connected to the bus after the host module. Partial termination terminates only the eight highest lines of the 16-bit SCSI bus and permits the lower eight lines to continue on the bus.

Note

When you change host parameters, you must use *Restart System* option from the *System Functions* menu to have the changes take effect.

Warning

Be sure to use System Shutdown whenever you need to power down the controller for maintenance. System Shutdown flushes any data left in the cache and prepares the controller for an orderly shutdown.



4.3.2 System Parameters

Use this screen to configure password checking, and set the date and time of the controller's system clock. This screen also sets the rates for rebuilds and creates.

```

Monitor Utility                                07-05-95
SYSTEM PARAMETERS                             18:10:18
-----
Parameter                                     Value
-----
Password Checking                             OFF
Date                                           07-05-95
Time                                           18:10:16
Rebuild Rate                                  1
Create Rate                                   1
UPS                                             Installed
Read-Ahead                                    ON
Read-Ahead Limit                              256
Validation Delay                              0
-----

```

ARROW KEYS: MOVE CURSOR | ENTER: SELECT | CTRL-Z: EXIT |

Password Checking: Enables or disables password checking. When password checking is enabled, the controller will limit access to the monitor utility unless the user enters the correct password. Without the correct password, the user will be able to see only the RAID Set Statistics, System Statistics, Rebuild/Create Status, and Event Log screens. Once you have turned password checking on, the controller will prompt for a password the next time you try to enter the monitor utility.

Date: Use this option to set the system date. Once you set the date, the controller's internal clock will keep the date current. This date is displayed on most monitor screens, and, more importantly, is stamped on all event log entries. To set the date, use the arrow keys to highlight the date field. Switch to edit mode by pressing Enter. Then use the left and right arrow keys to move among the month, day, and year fields, and the up and down arrow keys to spin the selected field up and down.

Time: Use this option to set the system time. Once you set the time, the controller's internal clock will keep the time current. This time value is displayed on most monitor screens, and, more importantly, is stamped on all event log entries. To set the time, use the arrow keys to highlight the time field. Switch to edit mode by pressing Enter. Then use the left and right arrow keys to move between the hour, minute, and second fields, and the up and down arrow keys to spin the selected field up and down.

Rebuild Rate: The controller will rebuild RAID sets at the same time it handles I/O activity from the host. The relative priority the controller gives to rebuilds on the one hand and I/O activity on the other is determined by the Rebuild Rate. This rate ranges from 1 to 100. A rate above 50 places a higher priority on rebuilds at the expense of I/O activity. A rates below 50 improves I/O response but causes rebuilds to take place at a slower rate.

Create Rate: As with rebuilds, the controller will perform RAID set creations at the same time it handles I/O activity from the host. The relative priority the controller gives to creates on the one hand and I/O activity on the other is determined by the Create Rate. This rate ranges from 1 to 100. A rate above 50 places a higher priority on creates at the expense of I/O activity. A rate below 50 emphasizes I/O response over the RAID set creation.

UPS: If you connect a uninterruptible power supply (UPS) to the controller, set this field to "Installed." This will cause the controller to watch for "two-minute warning" and "AC power fail" signals from the UPS and act accordingly. If you set this field to "Not Installed," the controller will not watch for these signals, even if a UPS is connected to the controller.

Read-Ahead: This option permits you to enable or disable read-ahead caching. When read-ahead is turned on, the controller will take in additional data with each read operation. This data will be stored in cache in anticipation that it will be requested in the next read operation. If the data is indeed requested, it can be fetched from cache rather than from the drive. This can greatly improve read performance when you are performing many reads from sequential data. If your data is non-sequential, read-ahead will actually slow read performance, because the controller will be reading extra data unnecessarily. In this case, you should turn read-ahead off.



Read-Ahead Limit: The controller always will limit the amount of read-ahead data it takes in to the amount of data left in the current chunk or the amount of data left on the current drive, whichever is smaller. The controller never will read-ahead to another drive, as this would impose an unwanted performance penalty. The user may further limit the scope of read-ahead operations by setting the read-ahead limit value. This is the *maximum* amount of data (in blocks) that the controller will read ahead. The controller still will select the smallest value among the read-ahead limit, the amount of data left in the current chunk, and the amount of data that can be read without shifting to another drive. You may find that changing the read-ahead limit can improve performance if you have selected a large chunk size. The default value is 256 blocks.

Validation Delay: This is the length of time (in seconds) that the controller will wait before attempting to validate the disk drives connected to it at power up. If you have disk drives that need extra time to spin up, set the validation delay to a value greater than the time it takes the drives to spin up. Otherwise, when the controller attempts to validate the drives at power up, it will fail to recognize them. You may select a validation delay of as long as 60 seconds.

4.3.3 Host LUN Mapping

This screen may be used to map LUNs on each host channel to a particular redundancy group. Or you may prevent a redundancy group from appearing on a host channel. Thus, for example, you may map redundancy group 1 to LUN 5 on host channel 0 and the same redundancy group to LUN 12 on host channel 1. Or you may make redundancy group 8 available on LUN 4 on host channel 0 and block access to it on host channel 1.

```

Monitor Utility                                02-09-96
HOST LUN MAPPING                               13:14:00
Channel 0
  
```

Host LUN	Redundancy Group	Host LUN	Redundancy Group
0	0	16	16
1	1	17	17
2	-	18	18
3	-	19	19
4	5	20	20
5	-	21	21
6	6	22	22
7	7	23	23
8	8	24	24
9	9	25	25
10	10	26	26
11	11	27	27
12	12	28	28
13	13	29	29
14	14	30	30
15	15	31	31

ARROW KEYS: MOVE CURSOR | N: NEXT CH | P: PREV CH | ENTER: SELECT | CTRL-Z: EXIT

4.3.4 Channel Settings

The CRD-5500 permits the I/O modules in slots 1, 2, and 3 to be configured as host or disk channel modules. The *Channel Settings* screen is the place to configure these modules. Use the up and down arrow keys to maneuver to the channel you wish to configure and press Enter. Then use the arrow keys to toggle between host and disk. Press Enter again to save your selection. Channel 0 is always a host channel and channels 4 through 6 are always disk channels, so the monitor utility will restrict access to these fields.

```

Monitor Utility                                02-09-96
CHANNEL SETTINGS                               13:20:49
  
```

Channel	Module Type	Module Description
0	HOST	16-Bit Single-Ended
1	HOST	16-Bit Differential
2	HOST	16-Bit Single-Ended
3	DISK	16-Bit Single-Ended
4	DISK	16-Bit Single-Ended
5	DISK	16-Bit Single-Ended
6	DISK	16-Bit Single-Ended
7	DISK	16-Bit Single-Ended
8	DISK	16-Bit Single-Ended

UP ARROW: CURSOR UP | DOWN ARROW: CURSOR DOWN | ENTER: SELECT | CTRL-Z: EXIT



Note

You must restart the controller when you change the setting of one or more channels. Use the *Restart System* option from the *System Functions* menu.

4.4 System Information

System Information offers the following views of your RAID system: *I/O Statistics*, *Free Lists Statistics*, *Manufacturing Information*, *Environmental Status*, and *I/O Process Information*. The *I/O Statistics* screen displays information that can help you determine how efficiently the controller is handling I/O requests.

```

Monitor Utility                                09-06-95
I/O STATISTICS                                15:33:31
ON
Rdncy Group : 0

-----
| Parameter | Rdncy Group/System |
-----
| Av QIO Size | 0/0 |
| Read (%) | 0/0 |
| Modified Count | 0/0 |
-----

-----
| Parameter | Cur | Min | Max | Av |
-----
| QIO's/Sec | - | 0 | 0 | - |
| Cache Hit Ratio | - | 0 | 0 | - |
-----

Sampling Period : 05 Secs
N: NEXT RGP | P: PREV RGP | UP/DOWN ARROWS: INC/DEC SAMPLE PERIOD | CTRL-Z: EXIT
    
```

The *Free Lists Statistics* screen shows the status of the controller's internal structures. This screen is intended primarily for use by technical support personnel, but some of the information is useful to know when you are configuring the controller. This is especially true of the *CB Resource* and *Usable Cache Size* values, which enter into the formula for selecting a chunk size (see page 4-10).

```

Monitor Utility                                02-19-96
FREE LISTS STATISTICS                          11:34:12

-----
| Resources | Used/Total | Parameter | Value |
-----
| CB | 0/126556 | System Idle | 98 % |
| PSCB | 0/126556 | Segment Write | 0 % |
| SGT | 0/4754 | Read/Modify/Write | 0 % |
| SCDRP | 0/400 | Create Parity Write | 0 % |
| CDRP | 3/200 | Combined Method Write | 0 % |
| IOP | 0/40 | No Parity Write | 0 % |
| BTN | 0/200 | Raid 1/JBOD Write | 0 % |
| PSBTN | 0/200 | Raid 0+1 Write | 0 % |
| RWR | 0/40 | XOR Block Count | 0 |
| MPWR | 0/40 | Modified List Count | 0 |
| DMT | 0/80 | Hash Table Count | 1 |
| EVL | 0/10 | Hash Table Size | 128.0 KB |
| ERRREC | 0/40 | Usable Cache Size | 61.8 MB |
| FET | 0/112 | Total Cache Size | 68.0 MB |
| TQE | 12/100 | Sample Period | 1 SEC |
-----

UP ARROW: INC SAMPLE PERIOD | DOWN ARROW: DEC SAMPLE PERIOD | CTRL-Z: EXIT
    
```

The *Manufacturing Information* screen is intended for authorized service technicians, but the user may find it useful for determining how much memory is installed in the cache and what kind of modules are installed in the I/O slots.



Monitor Utility
MANUFACTURING INFORMATION

02-09-96
11:54:11

Model Number	5500	Processor Type	33310
Serial Number	0000	Processor Clock	40 MHz
Date of Mfg.	02-07-96	Processor Memory	Processor DRAM
DRAM 0 ID	91	SIMM 0A Size	64 MB
DRAM 1 ID	91	SIMM 0B Size	
XOR ID	91	SIMM 1A Size	4 MB
PIC ID	91	SIMM 1B Size	
Channel 0	16-Bit Singled-Ended Host Module, ID 91		
Channel 1	16-Bit Differential Host Module, ID 91		
Channel 2	16-Bit Single-Ended Host Module, ID 91		
Channel 3	16-Bit Single-Ended Disk Module, ID 91		
Channel 4	16-Bit Single-Ended Disk Module, ID 91		
Channel 5	16-Bit Single-Ended Disk Module, ID 91		
Channel 6	16-Bit Single-Ended Disk Module, ID 91		
Channel 7	16-Bit Single-Ended Disk Module, ID 91		
Channel 8	16-Bit Single-Ended Disk Module, ID 91		

CTRL-Z: EXIT

The *Environmental Status* screen displays a snapshot of the crucial environmental factors that must be within the normal range for proper operation of the controller.

Monitor Utility
ENVIRONMENTAL STATUS

02-09-96
12:00:00

Parameters	Value	Status
5 Volt Level	5.00 V	Normal
12 Volt Level	12.00 V	Normal
SCSI Terminator Voltage Level	5.00 V	Normal
DRAM 0 Voltage Level	5.00 V	Normal
DRAM 1 Voltage Level	5.00 V	Normal
Backup Battery Voltage Level	0.00 V	Not Installed
Board Temperature	90 F	Normal
Enclosure Temperature	0 F	Not Installed

U: UPDATE | CTRL-Z: EXIT

5 Volt Level: The normal range is between 4.80 and 5.25 volts exclusive. When the system power voltage drops 4.80 volts or climbs to 5.25 volts, the controller will sound its alarm. When the voltage drops to 4.75 volts or climbs to 5.30 volts, the controller will shut down.

12 Volt Level: The normal range is from 10.8 volts to 14.4 volts.

SCSI Terminator Voltage Level: This should be in the range from 4.45 to 5.55 volts.

DRAM Voltage Levels: The voltage levels for DRAM 0 and DRAM 1 are controlled internally. Their readouts are intended for authorized service technicians only.

Backup Battery Voltage Level: This displays the voltage level from the battery backup if one is installed.

Board Temperature: This is the temperature as measured on the controller board. The controller will sound its alarm and issue a warning when the board temperature reaches 100 degrees Fahrenheit and shut down when the temperature reaches 120 degrees Fahrenheit.

Enclosure Temperature: This field is not implemented in the current firmware release.

The *I/O Process Information* screen is intended for use by authorized service personnel as a troubleshooting tool. It contains no information that the average user will find useful.

4.5 RAID Set Functions

This opens up a menu with options for creating and rebuilding RAID sets, as well as adding spares.



```

Monitor Utility                                07-05-95
MAIN MENU                                     18:10:59

+-----+
| RAID Set Information |
| Setup Parameters    |
| System Information  |
| RAID Set Functions  |
| System+             |
| Disk U | Create RAID Set |
| Rebuil | Rebuild Disk   |
| Event  | Add Spares     |
+-----+

```

UP ARROW: CURSOR UP | DOWN ARROW: CURSOR DOWN | ENTER: SELECT | CTRL-Z: EXIT

4.5.1 Create RAID Set

This is where you select the drives for and configure a new RAID set. Use the arrow keys to navigate among the fields. Press *Enter* to edit a field. Once you are in edit mode, use the arrow keys to spin through the available values. Then press *Enter* again to save the new value, or press *Ctrl-Z* to cancel the change.

Warning

If you edit a cell that represents a drive that is part of an existing RAID set, the controller will warn you that you are about to cause the RAID set to be degraded and ask you to confirm that you wish to proceed. If you edit another cell in the same RAID set, the controller will warn you that you are about to cause the RAID set to go offline and prompt for confirmation. Once you confirm either action, there is no way to undo what you have done.

The *Create RAID Set* screen will display installed disk channels only. If you have two disk channels installed, you will see two columns of drive IDs. If you have five disk channels, you will see five columns.

```

Monitor Utility                                02-09-96
CREATE RAID SET                               14:28:32

+-----+ +-----+ +-----+
| RAID Set | 0 | | RAID Level | 4 | | Partitions | 1 |
+-----+ +-----+ +-----+

      Ch 3   Ch 4   Ch 5   Ch 6   Ch 7   Ch 8
Id 0 | [Unkn] | [Unkn] | [Unkn] | [Unkn] | [Unkn] | [Unkn] |
Id 1 | [Unkn] | [Unkn] | [Unkn] | [Unkn] | [Unkn] | [Unkn] |
Id 2 | [Unkn] | [Unkn] | [Unkn] | [Unkn] | [Unkn] | [Unkn] |
Id 3 | [Unkn] | [Unkn] | [Unkn] | [Unkn] | [Unkn] | [Unkn] |
Id 4 | [Unkn] | [Unkn] | [Unkn] | [Unkn] | [Unkn] | [Unkn] |
Id 5 | [Unkn] | [Unkn] | [Unkn] | [Unkn] | [Unkn] | [Unkn] |
Id 6 | [Unkn] | [Unkn] | [Unkn] | [Unkn] | [Unkn] | [Unkn] |
+-----+ +-----+ +-----+ +-----+ +-----+ +-----+

ENTER: SELECT | C: CONTINUE | I: DRIVE INFO | CTRL-Z: EXIT

```

RAID Set: This is the number that the CRD-5500 will use to identify the RAID set. It is not necessarily the logical unit number (LUN) that your operating system will use to address the RAID set. The LUN is determined by the *Redundancy Group* number you assign to a particular RAID set or partition of a RAID set. You may specify a *Redundancy Group* number later in the creation process, or change the number with the *Host LUN Mapping* screen under the *Setup Parameters* screen. The controller will skip over any RAID set numbers already assigned as you spin through the values.

RAID Level: The CRD-5500 supports RAID levels 0, 1, 0+1, 4 and 5. It also supports JBOD (“Just a Bunch of Drives”). JBOD permits you to connect individual disk drives to the CRD-5500 and make them available as standalone disk drives to the host. You must perform a separate RAID set creation for each JBOD disk drive you create. The RAID set number you assign to the drive will be its LUN, unless you map the drive to a different LUN with the *Host LUN Mapping* screen. JBOD disk drives are useful when you want to connect a drive to the same host adapter as the CRD-5500, but you don't want to use another SCSI cable.

Drive Selection: The drives connected to the controller are depicted in an array organized by drive channel and SCSI ID. Drives that are not in use and thus available for selection will show up as *Unkn*



(Unknown). Drives that already have been assigned to a RAID set will be identified with the RAID Set number of which they are a member. To select a drive for inclusion in a RAID set, use the arrow keys to highlight the field for that drive. Press Enter to edit the field. Then use the arrow keys to spin through the available options: Onli (Online) and Unkn. Select Onli (Online) to make a drive an active member of the RAID set, and press Enter to save your selection. If you select a drive that already is part of a RAID set and set it to Unkn, the controller will warn you if you if this action will cause the existing RAID set to become degraded or go offline.

Partitions: This is the number of partitions to be created out of the RAID set. Each partition will have its own Redundancy Group number, which translates into the logical unit number (LUN) that the host will see, unless you map the group to another LUN with the Host LUN Mapping screen. You may create up to 16 partitions.

Drive Info: You may select any Channel/ID cell and press "I" to view information about the specified disk drive, such as in the example below. If you select an empty cell, the CRD-5500 will scan the SCSI bus and identify any disk drives added to the bus since the controller was last booted up.

```
-----
Disk Drive Information
For Channel 4, SCSI ID 0

Status: Unknown
Capacity: 2050 MB
Vendor: QUANTUM
Model: XP32150
Revision: 581H
-----
```

Note

The width (number of drives) of each partition is equal to the width of the RAID set that encompasses it. All partitions within a RAID set will have the same RAID level. The CRD-5500 does not support multiple RAID levels within the same RAID set.

In the example below, we have selected one drive on each of the available channels. The selected drives show up as Onli (Online). The RAID set number will be 0. The RAID level will be 4. And we will carve up the RAID set into four partitions.

```
Monitor Utility                                02-09-96
CREATE RAID SET                                14:30:22

+-----+-----+-----+-----+-----+-----+
| RAID Set | 0 | | RAID Level | 4 | | Partitions | 4 |
+-----+-----+-----+-----+-----+-----+

      Ch 3   Ch 4   Ch 5   Ch 6   Ch 7   Ch 8
+-----+-----+-----+-----+-----+-----+
Id 0 | Onli | | Unkn | | Unkn | | Unkn | | Unkn | | Unkn |
+-----+-----+-----+-----+-----+-----+
Id 1 | Unkn | | Onli | | Unkn | | Unkn | | Unkn | | Unkn |
+-----+-----+-----+-----+-----+-----+
Id 2 | Unkn | | Unkn | | Onli | | Unkn | | Unkn | | Unkn |
+-----+-----+-----+-----+-----+-----+
Id 3 | Unkn | | Unkn | | Unkn | | Onli | | Unkn | | Unkn |
+-----+-----+-----+-----+-----+-----+
Id 4 | Unkn | | Unkn | | Unkn | | Unkn | | Onli | | Unkn |
+-----+-----+-----+-----+-----+-----+
Id 5 | Unkn | | Unkn | | Unkn | | Unkn | | Unkn | | Onli |
+-----+-----+-----+-----+-----+-----+
Id 6 |  |  |  |  |  |  |  |  |  |  |
+-----+-----+-----+-----+-----+-----+

ENTER: SELECT | C: CREATE | I: DRIVE INFO | CTRL-Z: EXIT
```

After you have selected the drives for your RAID set, press C to continue to the next step of the creation process. The controller will ask you to enter a redundancy group number and chunk size for each partition. By default, the controller will assign a 256-block chunk size to each redundancy group, and equally apportion the available disk space to each redundancy group. If you specified just one partition on the previous screen and you specify less than the full disk capacity in the Partition Size column, the controller will create the redundancy group using only the specified portion of the RAID set.



Monitor Utility
CREATE RAID SET

02-19-96
14:46:36

Partition	Redundancy Group	Chunk Size (BLKS)	Partition Size (MB)
0	1	256	381
1	2	256	381
2	3	256	381
3	4	256	381

Capacity (Used/Total)	1522/1522 MB
-----------------------	--------------

ENTER: SELECT | C: CREATE | CTRL-Z: PREVIOUS PAGE |

Redundancy Group: The controller uses the redundancy group number to uniquely identify each RAID set or RAID set partition. It is this number that gets translated to the logical unit number the host will use to address the redundancy group. The redundancy group number should not be confused with the RAID set number. The RAID set number is an internal identification number only. Since a RAID set may be partitioned, a single RAID set number may have several redundancy group numbers associated with it.

Note

When you use the arrow keys to select a redundancy group number, the monitor utility will skip over any numbers that already have been assigned.

You may use the *Host LUN Mapping* screen under *Setup Parameters* to give each host channel a different view of the redundancy groups connected to the controller. For instance, you could have host channel 0 see a redundancy group as LUN 1, and host channel 1 see the same redundancy group as LUN 5. You may also prevent one host channel from seeing a redundancy group, while making it available on the other host channel.

Chunk Size: RAID systems “stripe” data when writing to the array. This means that data from the host is broken up into smaller chunks, with each chunk then being written to a disk in the array. The size of these chunks (measured in logical blocks) is determined by the Chunk Size parameter.

For best results, use the following rules when you are selecting a chunk size:

- The chunk size should be a multiple of 32.
- The maximum chunk size is 1024 blocks.
- For fastest sequential writes use large chunk size (128 or 256 blocks).
- For fastest sequential reads use small chunk size (32 or 64 blocks).
- For normal usage, with a combination of reads and writes, use a chunk size of 96 or 128 blocks. This should make the chunk size around 3 to 10 times the average block size.
- If you have many LUNs with many drives and a large chunk size, use the following formula to verify that you have sufficient cache memory. The chunk size multiplied by the number of drives in the RAID set (including the parity drive) multiplied by two should be less than the total usable cache. Look on the Free Lists Statistics screen for the amount of usable cache in the controller (see page 4-6). This value is displayed in the lower right portion of the screen, across from the label “Usable Cache Size.” Since this value is expressed in megabytes and the chunk size in blocks, you must multiply the “Usable Cache Size” value by 2048 to convert it to blocks. (There are 512 bytes in a block and 1048576 bytes in a megabyte.)

$$\text{ChunkSize} \times \text{Number_Of_Drives} \times 2 < \text{Usable_Cache_Size}$$

Here is an example of a calculation to verify that the controller with 4 megabytes in its cache has sufficient memory for a RAID set with 12 drives and a chunk size of 512 blocks:

- 1 Multiply the chunk size (512) by the number of drives (12) and double the product (result = 12288 blocks).



- 2 Convert the "Usable Cache Size" displayed on the Free Lists Statistics page to blocks by multiplying the value (3.6 MB) by 2048 (result = 7372.8).

```

Monitor Utility                                02-19-96
FREE LISTS STATISTICS                          11:34:12
-----+-----+-----+-----+
| Resources | Used/Total | Parameter | Value |
+-----+-----+-----+-----+
| CB        | 0/7372    | System Idle | 98 % |
| PSCB     | 0/7372    | Segment Write | 0 % |
| SGT      | 0/4754    | Read/Modify/Write | 0 % |
| SCDRP    | 0/400     | Create Parity Write | 0 % |
| CDRP     | 3/200     | Combined Method Write | 0 % |
| IOP      | 0/40      | No Parity Write | 0 % |
| BTN      | 0/200     | Raid 1/ JBOD Write | 0 % |
| PSBTN    | 0/200     | Raid 0+1 Write | 0 % |
| RWR      | 0/40      | XOR Block Count | 0 |
| MPWR     | 0/40      | Modified List Count | 0 |
| DMT      | 0/80      | Hash Table Count | 1 |
| EVL      | 0/10      | Hash Table Size | 128.0 KB |
| ERRREC   | 0/40      | Usable Cache Size | 3.6 MB |
| FET      | 0/112     | Total Cache Size | 4.0 MB |
| TQE      | 12/100    | Sample Period | 1 SEC |
+-----+-----+-----+-----+
UP ARROW: INC SAMPLE PERIOD | DOWN ARROW: DEC SAMPLE PERIOD | CTRL-Z: EXIT

```

- 3 The value from step 1 (12288 blocks) is greater than the value from step 2 (7372.8), so the chunk size is too large. You must reduce the chunk size to avoid overwhelming the available memory. A smaller chunk size, such as 256 blocks, would be a better value.

Partition Size: This is the size in megabytes of each partition. By default, the controller will try to equally apportion the available disk space to each partition. If you change the default values, the controller will display a running total of the allotted disk space in the Capacity (Used/Total) box. If the total size of the partitions you specify exceeds the total capacity of the disk drives in the RAID set, the *Used* field will be filled with asterisks (e.g., ****).

To complete the creation, press *C* again and *Enter* to confirm the action.

4.5.1.1 Deleting a RAID Set

The CRD-5500 has no menu option for deleting a RAID set. However, you may delete a RAID set by going to the Create RAID Set screen under RAID Set Functions and creating a new RAID set with some or all of the drives from the RAID set you wish to delete. You do not necessarily have to select all the drives from the old RAID set, just enough to cause the old RAID set to go offline. For RAID 4 and 5, this means that you must select at least two drives. For RAID 0, one drive will suffice. For RAID 1 and 0+1, you should select all drives.

When you delete a RAID set by reusing its disk drives, the RAID Set number displayed on the Create RAID Set screen will not correspond with the RAID set you are deleting. It will automatically display the next available RAID set number. For instance, if you have two RAID sets active, RAID Set numbers 0 and 1 will be taken. Therefore, if you set out to delete one of the RAID sets, the RAID Set number displayed on the screen will be 2, as in the following example.

```

Monitor Utility                                02-09-96
CREATE RAID SET                                14:30:22
-----+-----+-----+-----+
| RAID Set | 2 | RAID Level | 4 | Partitions | 1 |
+-----+-----+-----+-----+
| Ch 3 | Ch 4 | Ch 5 | Ch 6 | Ch 7 | Ch 8 |
+-----+-----+-----+-----+
| Id 0 | 0 | 0 | 0 | 0 | 0 | 0 |
+-----+-----+-----+-----+
| Id 1 | 1 | 1 | 1 | Unkn | Unkn |
+-----+-----+-----+-----+
| Id 2 | 1 | Unkn | Unkn | Unkn | Unkn | Unkn |
+-----+-----+-----+-----+
| Id 3 | Unkn | Unkn | Unkn | Unkn | Unkn | Unkn |
+-----+-----+-----+-----+
| Id 4 | Unkn | Unkn | Unkn | Unkn | Unkn | Unkn |
+-----+-----+-----+-----+
| Id 5 | Unkn | Unkn | Unkn | Unkn | Unkn | Unkn |
+-----+-----+-----+-----+
| Id 6 | Unkn | Unkn | Unkn | Unkn | Unkn | Unkn |
+-----+-----+-----+-----+
ENTER: SELECT | C: CREATE | I: DRIVE INFO | CTRL-Z: EXIT

```



If, for example, the RAID set to be deleted comprises five drives, and it was configured for RAID level 5, you could delete the RAID set by selecting any two of the drives. In the example above, you could delete RAID set 0 by selecting the drives on Ch. 3/ID 0 and Ch. 4/ID 0 (or any other two drives in the RAID set). After the first drive, you will see a message warning you that the RAID set will be degraded. When you select the second drive, the controller will warn you that you are about to destroy the RAID set. These messages are normal, and you should confirm that you wish to take each step if you truly wish to delete the RAID set.

Warning

When you take a RAID set offline by entering the Create RAID Set screen and selecting the requisite number of drives to destroy the RAID set, the CRD-5500 will immediately rewrite the home block areas on all the drives in the RAID set, rendering it impossible to reconstitute the RAID set once you have take the RAID set offline.

By deleting a RAID set in this manner, you end up with a gap in the RAID set number sequence. In the example above, if the RAID set you deleted was RAID set 0, the result of the deletion would be two RAID sets: RAID set 1 and RAID set 2. (RAID set 1 existed before the deletion, and RAID set 2 was created during the deletion.) Since by default, the CRD-5500 maps RAID sets to SCSI logical unit numbers in a one-to-one fashion, this would result in RAID sets on LUNs 1 and 2. SCSI host adapters identify the devices on the SCSI bus by querying each SCSI ID and LUN. To save time, if the adapter finds no device on a LUN, it skips the remaining LUNs on that SCSI ID and resumes its search on LUN 0 of the next SCSI ID. If you have a gap in your RAID set numbers, your SCSI host adapter most likely will not recognize the RAID sets whose RAID set numbers fall after the gap. Therefore, when you delete a RAID set, you must take one of the following steps:

- 1 Recreate the new RAID set, and this time select the RAID set number that is needed to fill in the RAID set numbering gap.
- 2 Leave the number of the new RAID set alone and use the Host LUN Mapping screen to map the RAID set to the missing LUN.

4.5.2 Rebuild Disk

When a disk drive fails and the controller cannot find a suitable spare, you must replace the failed drive and then rebuild the data on the drive. The rebuild operation is initiated from the *Rebuild Disk* screen.

```

Monitor Utility                                02-09-96
REBUILD DISK                                  15:10:56

-----
| Degraded RAID Set To Rebuild | 0 |
-----

   Ch 3   Ch 4   Ch 5   Ch 6   Ch 7   Ch 8
Id 0 | 0 | |Unkn| |Unkn| |Unkn| |Unkn| |Unkn|
Id 1 |Unkn| | 0 | |Unkn| |Unkn| |Unkn| |Unkn|
Id 2 |Unkn| |Unkn| | 0 | |Unkn| |Unkn| |Unkn|
Id 3 |Unkn| |Unkn| |Unkn| | 0 | |Unkn| |Unkn|
Id 4 |Unkn| |Unkn| |Unkn| |Unkn| | 0 | |Unkn|
Id 5 |Unkn| |Unkn| |Unkn| |Unkn| |Unkn| |   |
Id 6 |   | |   | |   | |   | |   | |   |

ENTER: SELECT | R: REBUILD | I: DRIVE INFO | CTRL-Z: EXIT
    
```

To rebuild a disk, select a degraded RAID set, set the replacement drive to *Onli* (Online), and press “R” to initiate the rebuild, and Enter to confirm the action. In the above example, the drive on Ch. 6, ID 5 failed. To rebuild the RAID set, we must select another drive, set it to *Onli* and press “R” to start the rebuild.

You may connect the replacement drive to any channel and assign any available ID to it. The controller does not require you to insert a new drive in the exact position of the drive it replaces.



The CRD-5500 supports concurrent rebuilds on RAID 1 and RAID 0+1 sets. These RAID levels can survive the loss of more than one member, as long as one member (RAID 1) or one stripe set (RAID 0+1) remains. For instance, if you lose two drives out of a three-member RAID 1 set, the controller can still access the data since the same data is written to each drive. You could then initiate a concurrent rebuild on the two dropped drives. Concurrent rebuilds do not apply to the other RAID levels, because the loss of more than one drive on any of these RAID levels will break the RAID set.

Note

The size of the replacement drive must be greater than or equal to the smallest drive in the degraded RAID set or the drive it is replacing, whichever is smaller.

Drive Info: You may select any Channel/ID cell and press “I” to view information about the specified disk drive. If you select an empty cell, the CRD-5500 will scan the SCSI bus and identify any disk drives added to the bus since the controller was last booted up.

4.5.3 Add Spares

Use the *Add Spares* screen to add or delete spare drives, or to intentionally delete a drive from a RAID set (thus degrading the RAID set) for maintenance purposes.

```

Monitor Utility          02-09-96
ADD SPARES              14:30:22

```

	Ch 3	Ch 4	Ch 5	Ch 6	Ch 7	Ch 8
Id 0	0	Unkn	Hot	Unkn	Unkn	Hot
Id 1	Unkn	0	Unkn	Warm	Unkn	Unkn
Id 2	Unkn	Unkn	0	Unkn	Unkn	Unkn
Id 3	Unkn	Warm	Unkn	0	Warm	Unkn
Id 4	Unkn	Unkn	Unkn	Unkn	0	Unkn
Id 5	Hot	Unkn	Unkn	Unkn	Unkn	0
Id 6						

ENTER: SELECT | S: ADD SPARE | I: DRIVE INFO | CTRL-Z: EXIT

To change a drive's designation, use the arrow keys to navigate to that drive's Channel-ID field, press Enter to switch to edit mode, spin through the available values with the arrow keys, then press Enter to save the change, or Ctrl-Z to exit editing mode without saving the change. For spares, you can select from Hot and Warm. You may select multiple spares and add them in one operation.

Hot Spare: A hot spare is powered-up and spun-up at all times to be ready for action at a moment's notice. Since a hot spare is always spinning, it is subject to almost as much wear and tear as an active drive.

Warm Spare: A warm spare is powered-up at all times, but the controller will spin-up the drive only when it is needed to replace a failed drive. This slows the spare's response to a drive failure, but it reduces the chance that the spare will fail before it is called into action.

Note

Hot and warm spares on the CRD-5500 are global. They are not assigned to a specific RAID set. When the controller detects a drive failure, it scans the first drive channel from ID 0 to 6, then the next channel from ID 0 to 6, and so on, until it finds a spare that is large enough to serve in the degraded RAID set. If it finds one, it automatically initiates a rebuild on the spare. If you want hot spares to take precedence over warm spares, be sure to put them on lower channels and IDs than warm spares.

Drive Info: You may select any Channel/ID cell and press “I” to view information about the specified disk drive. If you select an empty cell, the CRD-5500 will scan the SCSI bus and identify any disk drives added to the bus since the controller was last booted up.



Once you have entered your changes, press *S* to add the spares.

To view the progress of a rebuild, select *Rebuild/Create Status* from the main menu.

4.6 System Functions

This opens a menu with options for your changing password, loading and saving a controller configuration, loading new system code, restarting the system, and shutting down the controller.

```

Monitor Utility                                02-19-96
MAIN MENU                                     11:40:32

+-----+
| RAID Set Information |
| Setup Parameters    |
| System Information  |
| RAID Set Functions  |
| System Functions    |
+-----+
| Change Password     |
| Restart System      |
| System Shutdown     |
| Load System Code    |
| Download Drive Firmware |
+-----+
UP ARROW: CURSOR UP | DOWN ARROW: CURSOR DOWN | ENTER:SELECT | CTRL-Z: EXIT

```

4.6.1 Change Password

The CRD-5500 offers password protection to prevent unauthorized users from accessing sensitive portions of the monitor utility. The password may be from one to nine characters long and contain any combination of case-sensitive alphanumeric characters. To enable password protection, select *System Parameters* from the *Setup Parameters* menu (see page 4-4).

Note

The default password for the controller is *Viper* (with an uppercase V.)

To change the password, select *Change Password* from the *System Functions* menu and follow the prompts. The controller first will ask you for your current password. If this is your first crack at changing the password, enter the default password, *Viper*. Next, enter the new password. Finally, the controller will ask you to confirm the new password by reentering it.

4.6.2 If You Forget Your Password...

If you forget your password, enter *lostpassword* (no space) at the password prompt. The controller will display an access code. Your reseller will be able to use these characters to generate another code that will reset the controller's password to its default setting.

4.6.3 Load System Code

The *Load System Code* option on the menu is not functional at this time. To update the flash EPROM containing the controller's firmware, follow the directions in this section. (The version number of your current firmware is displayed in the title box of the monitor utility's opening screen.)

CMD Technology makes the latest version of the CRD-5400 firmware available on its BBS. Set your communications software to 8 data bits, 1 stop bit and no parity. The BBS will support up to 19200 baud. The primary BBS line is (714) 454-0795. Use (714) 454-1134 as an alternate line. You may also receive the firmware code by Internet e-mail. To request new firmware code, send an e-mail message to tech-support@cmd.com. The technical support department will respond with an e-mail message containing the code. Whether you download the code from the BBS or receive it via e-mail, the code will be in ASCII format, which the controller will convert into binary code.



- 1 Begin the code transfer by restarting the controller. Press Ctrl-C as soon as the controller begins its self-test routine. You will see the following menu:

FLASH Boot Utility Options

- 1) Download new Firmware Image
- 2) Change serial baud rate ;use faster baud for download
- 9) Restart Controller

- 2 If your computer allows it, you may want to change the serial baud rate to 19200 or 38400 for faster upload time by selecting "2) Change serial baud rate."
- 3 Select "1) Download new Firmware Image."

Note

If you are using a DOS or Windows communications application, you must instruct the application to end each text line with a carriage return/line feed. For instance, if you are using the Terminal application in Windows, you would select Transfers, Select Text File and check the Append LF check box, as the following example shows.

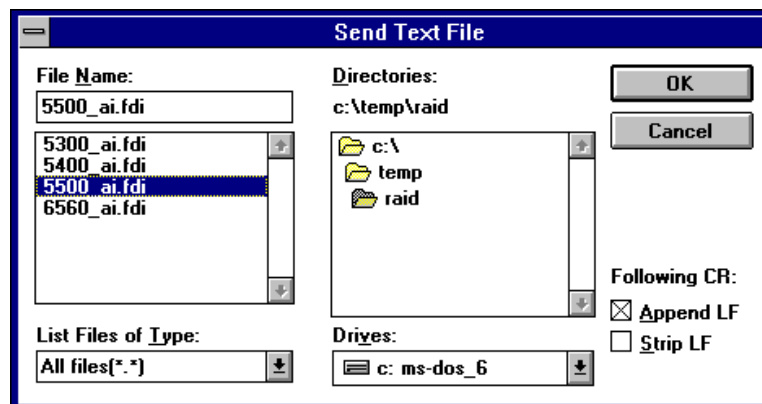

Figure 4-1: Send text file setup in Windows 3.1

If you are using the HyperTerminal application in Windows 95, select File, Properties. Then click on the Settings tab. Then click the ASCII Setup button. When the following dialog box appears, check the "Send line ends with line feeds" box.

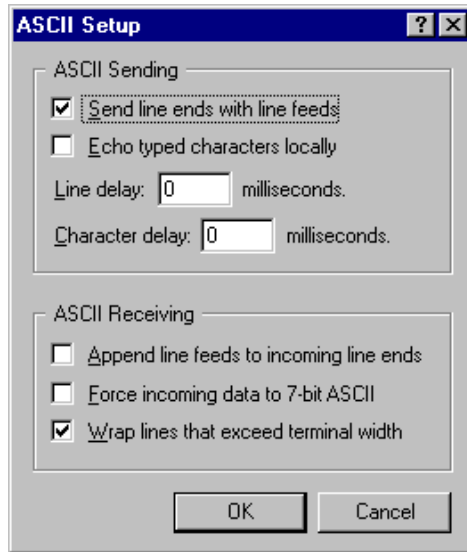

Figure 4-2: Send text file setup in Windows 95

- 4 Send the new firmware to the controller like a text file (the file option will be FDI). During the upload, the controller will display a small rotating character on the lower right corner of screen to indicate that the upload is in progress.

Note

If you get line overflow it means you did not send line feeds at the end of each line.

- 5 Once the upload finishes, the controller will prompt you to lower the baud rate back to 9600 on the terminal emulator program.

If the loading of system code fails for any reason, the controller will inform you of the failure and offer to retry the load. Since the loading process erases the old code in the EPROM, the controller will not operate until you succeed in loading new code.

4.6.4 Restart System

The Restart System option reinitializes the controller, loading any host parameter changes in the process.

Note

When you change the controller's host parameters, you must restart the system to initialize the new values. Any changes you make will not take effect until you perform a restart.

4.6.5 System Shutdown

If you should need to power down the controller, select *System Shutdown* prior to shutting off power. This will cause the controller to immediately flush its cache and proceed with a graceful shutdown.



4.6.6 Download Drive Firmware

This screen supports the downloading of firmware to selected drives connected to the CRD-5500. The firmware and program for transmitting the code must be supplied by the drive manufacturer. You must make sure that you select the drives for which the code is designed.

```

Monitor Utility          02-09-96
DOWNLOAD DRIVE FIRMWARE 14:30:22

   Ch 3   Ch 4   Ch 5   Ch 6   Ch 7   Ch 8
Id 0 |Dnld| |Dnld| |Dnld| |Dnld| |Dnld| |Dnld|
Id 1 |  | |Unkn| | 1 | | 1 | | 1 | |  |
Id 2 |  | |Hot | | 1 | | 1 | | 1 | |  |
Id 3 |  | |Unkn| |Hot | |Unkn| |Unkn| |  |
Id 4 |  | |Hot | | 2 | |Unkn| |Unkn| |  |
Id 5 |  | | 1 | | 3 | |Hot | |Hot | |  |
Id 6 |  | |  | |  | |  | |  | |  |

ARROW KEYS: MOVE CURSOR | ENTER: SELECT | S: SET TO DOWNLOAD | CTRL-Z: EXIT

```

Select the drives to which you wish to download firmware by setting their cells to Dnld. When you have finished selecting the drives, press “S” to prepare the controller for the download. Then issue the appropriate commands from the host to transfer the new code to the drives.

Note

The CRD-5500 will suspend I/O activity to the RAID sets containing the drives targeted for firmware downloads.

4.7 Disk Utilities

The *Disk Utilities* functions are not implemented in the current firmware version.

4.8 Debug Utilities

The utilities accessible through this menu are intended for use by authorized service personnel.

Warning

The use of debug utilities during I/O activity can cause the SCSI bus or the controller to hang.

4.9 Rebuild/Create Status

This screen provides a continuously updated view of the progress of rebuild and create operations.

Here is an example of a *Rebuild/Create Status* screen.



```

Monitor Utility                                02-19-96
REBUILD/CREATE STATUS                          11:50:46
-----
0
Creating RAID Set 1                            Estimated Time: 00:07:23
##### 33%                                     Elapsed Time: 00:02:56
1
Rebuilding Member 0 Of RAID Set 0             Estimated Time: 00:04:16
##### 10%                                     Elapsed Time: 00:01:05
2
Rebuild Completed For Member 2 Of RAID Set 2   Date Completed: 02-19-96
                                                Time Completed: 11:42:16
3
-----
4
-----
5
-----
CTRL-Z: EXIT

```

4.10 Event Log

The CRD-5500 maintains a running log of controller-related events. These events include the initiation and completion of RAID set creations and rebuilds, drive failures, and SCSI messages emanating from the host and drive channels, among other events. Technical support personnel will find the event log useful in diagnosing problems with the controller.

Note

Event log data is stored in a portion of the controller's cache memory. If you have backed up the controller with an external battery or UPS, the event log will persist in memory, even if the controller is powered off or restarted.

To view the event log, select *Event Log* from the main menu. The first event in the log will be displayed. The following is an example of a SCSI event.

```

Monitor Utility                                02-09-96
EVENT LOG                                       15:00:34
-----
Sequence Number      0                Date                02-09-96
Recorded Event       SCSI                Time                11:11:35
-----
RAID Set             NA                RAID Level          NA
RAID Set Status     NA                Redundancy Group    NA
Logical Member       NA                Partitions          NA
-----
I/O Channel         3
SCSI ID             0
SCSI Command        00 00 00 00 00 00 00 00 00 00 00
SCSI Sense Data     70 00 06 00 00 00 00 0a 00 00 00 00 29 00 01 00 00 00
SCSI Phases         03 02 07 00 FF 19 0F 07 01 03 01 19 0F 02 07 04
Retry Attempt        0
SCDRP               80114D20
CDRP                00000000
-----
UP ARROW: NEXT EVL | DOWN ARROW: PREV EVL | F: FLTR | C: CLR LOG | CTRL-Z: EXIT

```

You may use the arrow keys to scroll forward and backward through the event log, or "C" to clear the log. If you want to view selected events, press "F" to filter the display. You will be presented with a menu of filters for extracting the events that interest you. Once you select a filter, you may scroll through the resulting display with the up and down arrow keys.



```
Monitor Utility      02-09-96
EVENT LOG           15:23:01
```

```
+-----+
| Select Event Log Filter |
+-----+
| All Recorded Events    |
| Starting Sequence Number |
| Starting Date and Time |
| Event Type             |
| RAID Set Number       |
| Disk I/O Channel      |
| Disk I/O Channel and SCSI ID |
+-----+
```

```
ENTER: SELECT | CTRL-Z: EXIT
```

All Recorded Events: This option restores the unfiltered view of events. The controller will display the next event log based on the last directional key pressed. If no directional key was pressed, the last event will be displayed.

Starting Sequence Number: If you select this filter, you will be prompted for a starting sequence number. If the controller finds an event with the specified sequence number, it will display the description for that event. You may use the arrow keys to scroll forward or back through the sequence of events

Starting Date and Time: All events are stamped with the time and date of their occurrence. By selecting this filter, you can jump to the first event that meets the date and time criteria you specify. Once the initial event is displayed, you may use the arrow keys to scroll forward and backward through the remaining events.

Event Type: This filter permits you to specify the type of event you wish to see, to the exclusion of all others. Table 4-1 lists the types of events you may select in the filter prompt.



Table 4-1: Event Types

Event Type	Description
Unknown	Returns any events that the controller could not classify.
Reassigned Block	The controller records a reassigned block event whenever a SCSI reassign block command is issued.
Host	The controller logs a host event whenever it cannot respond to a SCSI command from the host with good status.
Validation Conflict	If the controller detects a problem with a RAID set (such as a drive showing up as a member of more than one RAID set) during its power up routine, it logs a validation conflict.
Drive	This event is reserved for future use in a subsystem environment.
Fan	This event is reserved for future use in a subsystem environment.
Temperature	This event is reserved for future use in a subsystem environment.
Dropped Drive	Whenever a disk drive drops out of a RAID set either due to a failure or an action by the operator, the controller will record a dropped drive event.
Rebuild Done	The conclusion of a rebuild operation.
Create Done	The completion of a RAID set creation.
Rebuild Initiated	The start of a rebuild.
Create Initiated	The start of a RAID set creation.
Parity	Occurs whenever the controller detects a parity error on the controller's SCSI buses or internal bus.
Port	This event refers to an error that the CRD-5500's port driver detected while attempting to communicate with disk drives. A drive staying on the SCSI bus too long, or a drive disconnecting from the bus when it isn't supposed to are examples of port events.
SCSI	These events are reported by the disk drives connected to the controller. Refer to the SCSI specification for an explanation of the data displayed in these event logs.
Forced Error Written	Occurs whenever the controller issues a SCSI write long command.
Add Spare Started	Occurs when a drive has been picked as a spare and has passed all of its preliminary checks.
Add Spare Completed	The completion of an add spare operation.
System Power Up	Records that date and time whenever the controller is powered up or restarted.
System Shutdown	Records the time and reason of a system shutdown.
IES	Occurs whenever the controller detects a change in its internal environment.
Host Sync Negotiation	Occurs whenever the host performs a SCSI synchronous negotiation with the controller's host process.
Port Sync Negotiation	Occurs whenever the controller's port driver successfully completes a SCSI synchronous negotiation with a disk drive.
Host Wide DMA Negotiation	Occurs when the host performs a SCSI wide DMA negotiation with the controller's SCSI host process.
Port Wide DMA Negotiation	Occurs when the controller's port driver successfully completes a SCSI wide DMA negotiation.

RAID Set Number: Use this filter to view events related to a specific RAID set number.

Disk I/O Channel : Use this filter to view events related to a specific disk I/O channel.

Disk I/O Channel and SCSI ID: Use this filter to view events related to a specific device, identified by its I/O channel and SCSI ID.



5 Front Panel

The controller's front panel provides a means to get a quick glimpse of the status of your RAID sets. It does not offer the capability to change parameters or perform RAID set functions.

5.1 Main Menu

After the controller's startup sequence, the front panel will display the manufacturer and model number of the controller. To enter the main menu, press the SEL button. You will see the following screen.

```
MAIN MENU
RAID SET STATUS
```

The main menu contains two items: RAID Set Status and Front Panel Tests. To toggle between the two items, press the up and down arrow buttons. Press SEL to select your menu choice. Press EXIT to return to the opening screen.

Note

You may shut off the controller's alarm from the front panel by pressing the up and down arrow buttons at the same time. You also may disable the alarm from the monitor keyboard by pressing Ctrl-x.

5.1.1 RAID Set Status

If you select RAID Set Status, you will see a screen such as the following:

```
LUN 0
STATUS NONDEGRADED
```

The LUN number is equivalent to the redundancy group number displayed in the monitor utility. The status will indicate if the LUN (redundancy group) is DEGRADED, NONDEGRADED, or UNUSED. Press the up and down arrow buttons to cycle through your redundancy groups. Press EXIT to return to the main menu.

5.1.2 Front Panel Tests

This menu option takes you to a set of routines designed to configure the display and test the soundness of the front panel display and buttons. Use the arrow keys to spin through the tests. Press SEL to perform the selected test.

Set LCD Contrast: This option makes it possible to change the contrast of the front panel display. After you press SEL to select the option, press the up and down arrows to increase or decrease the display's contrast. You may hold a button down to quickly proceed up or down through the contrast range. Press EXIT when you have reached the desired contrast.

Alarm Test: Use this option to test the controller's alarm and Fault LED on the front panel. The up arrow button turns the alarm and LED on. The down arrow button shuts them off. When you are done with the test, press EXIT to return to the main menu.

Key Switch Test: This option enables you to test the front panel's buttons. When you have entered this test, the display will show the name of the button when you push it. When you press the EXIT button, "EXIT" will appear on the display, and after about four seconds, the display will return to the main menu.



Pixel Test: This test checks the soundness of the display. The up arrow button causes all the display's pixels to light up. The down arrow sends a regular binary pattern to the display.



6 CRD-5500 Redundant RAID Controller Kit

6.1 Introduction

Two CRD-5500s may be combined to form a fault-tolerant system. If either controller detects that the other controller is not functioning properly, it automatically assumes responsibility for all system I/O activity. This switch over occurs automatically and virtually instantly. If you have two CRD-5500 controllers equipped with multiple host channels, you may designate individual host channels as either active or passive, providing a means to balance I/O activity between controllers.

6.2 Requirements

To combine two CRD-5500s as a redundant pair, both controllers must be configured as follows:

- 1 Both controllers must be equipped with the 5552 motherboard. Controllers with the 5552 motherboard will have a serial number of 5000 or higher.
- 2 Both controllers must be running the same firmware revision (B.0 or higher).
- 3 The amount of cache installed in each controller must be the same.
- 4 The amount of cache installed in SIMM slots 0A and 1A must equal the amount installed in slots 0B and 1B, as described in section 6-3.
- 5 The same number of SCSI I/O modules must be installed in each controller.
- 6 The type of I/O module installed in each slot on one controller must be the same as that installed in the corresponding slot on the other controller.
- 7 Each disk must be connected to the same disk channel on each unit.
- 8 Corresponding host modules on each controller must also be connected on the same SCSI host busses.
- 9 The Redundant Controller Communication (RCC) cable must be connected between the two controllers.
- 10 Each controller must have its own dedicated monitor.



-
- 11** Each controller should have a battery connected to it. At least one of the controllers must have a battery connected to it, to protect the cache data in the event of a power failure.

NOTE

If two CRD-5500s are connected into a redundant controller configuration, the maximum number of disk drives that can be supported (with a single host) is 48. The maximum number of disk drives on a single channel is 6, and the maximum SCSI ID for a disk drive on any drive channel is 5.

6.3 SIMM Installation

To utilize the redundant controller capability of a pair of CRD-5500s, both units must have the same amount of SIMM cache installed. Refer to the CRD-5500 User's Manual for information on purchasing SIMMs.

WARNING

Be sure to remove all power (including battery power) to the controller before installing SIMMs. Observe all anti-ESD shop practices before you touch a SIMM.

On the 5552 motherboard, slots 0A and 1A form one set of cache memory. Slots 0B and 1B form another set. While one set is reading and writing data, the other set is “mirroring” the read/write. In the event of one CRD-5500's failure, one of the two halves of cache memory in the surviving CRD-5500 takes over the failed unit's read/write functions. Refer to Figure 6-1.

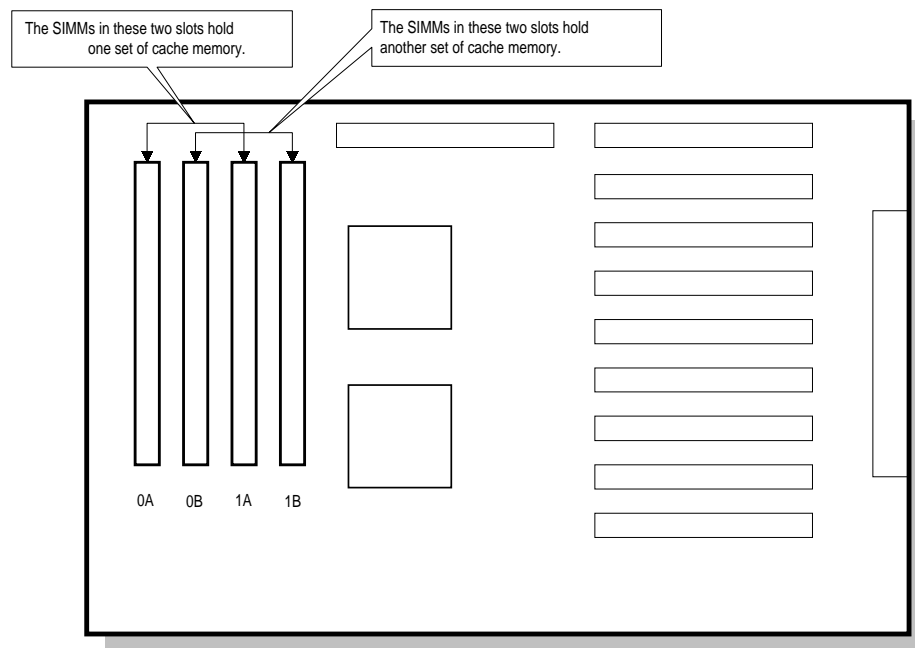

Figure 6-1: Arrangement of SIMM slots on 5552 motherboard

NOTE

It is not necessary for the SIMM configuration to be congruent as long as the same amount of memory is installed in each slot pair. For example: if a 64MB SIMM is in slot 0A, a 32MB SIMM is in slot 0B and a 32MB SIMM is in slot 1B, the requirements are met even though slot 1A is empty.

CMD recommends that SIMMs from the same manufacturer be used in any one CRD-5500.



If you are installing only one SIMM in a slot pair, use slot 0A or slot 0B as appropriate.



6.4 RCC Cable Connection

WARNING

Do NOT force the RCC cable connectors into the redundant controller connectors. Serious damage may result.

To function in the redundant controller mode, the two identically configured CRD-5500 controllers must be connected together with the specially provided redundant controller communication (RCC) cable. The cable must be twisted so that pin 1 on one controller matches pin 50 on the other controller, as shown in Figure 6-2.

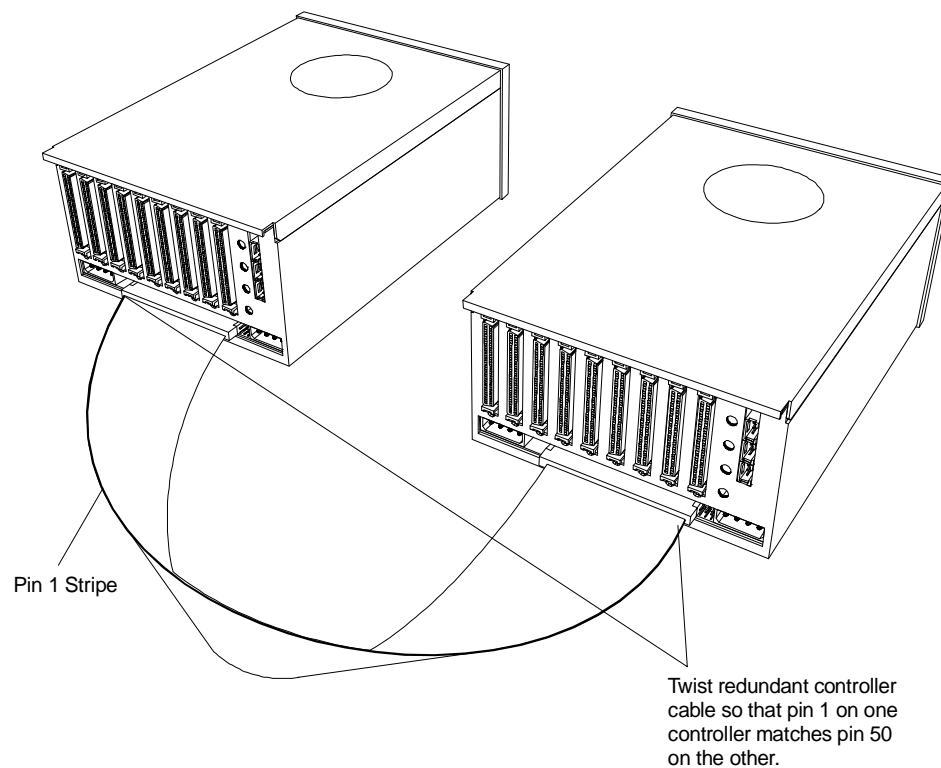

Figure 6-2: Redundant Controller Communication (RCC) Cable Installation



Figure 6-3 details assembly information for the RCC cable.

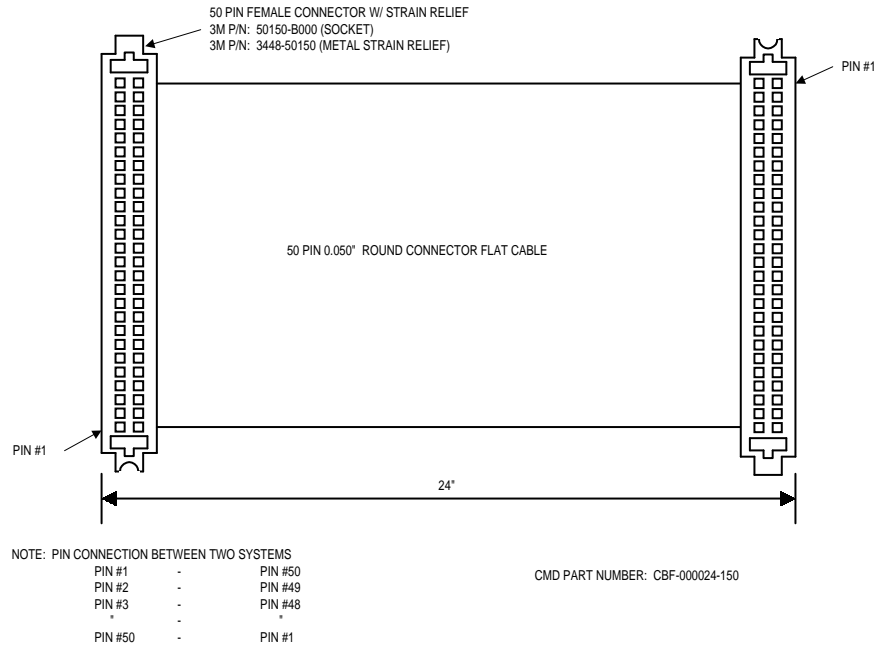

Figure 6-3: RCC Cable Assembly Information



6.5 Single-Host Configuration Examples

NOTE

The following examples are intended to illustrate the general principles of configuring a redundant controller system, and should not be construed to imply that they are the preferred or recommended method.

Figure 6-4 depicts one typical redundant controller configuration with two host channels per controller and a single host. Table 6-1 lists host channels, SCSI IDs and status for a typical single-host configuration.

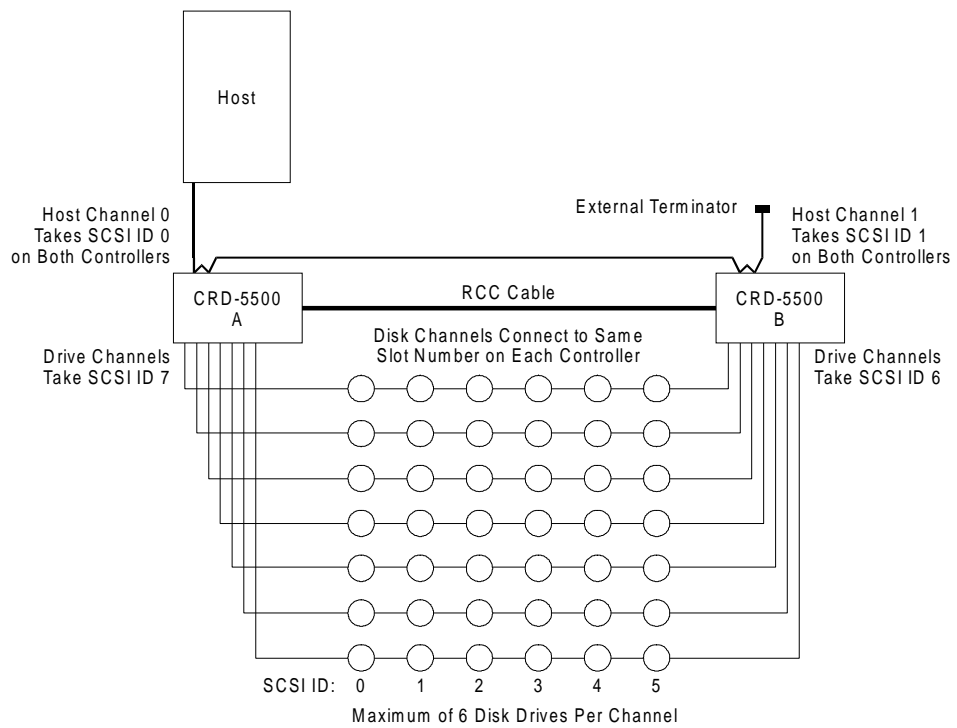

Figure 6-4: Single-host cabling diagram (example 1)

**Table 6-1: Example Configuration for Single-Host System**

Controller/Host Channel	SCSI ID	Status
A/0	0	Active
A/1	1	Passive
B/0	0	Passive
B/1	1	Active



By using Host LUN Mapping, you may balance I/O traffic between controllers by assigning some of your RAID sets to one host channel and the remainder to the other host channel. In the above example, RAID sets mapped to host channel 0 would be handled by controller A. RAID sets mapped to host channel 1 would be handled by controller B.

Figure 6-5 depicts another typical redundant controller configuration. This configuration offers greater throughput than the one shown in Figure 6-4. Host channels, SCSI IDs and status for this configuration are the same as in Table 6-1.

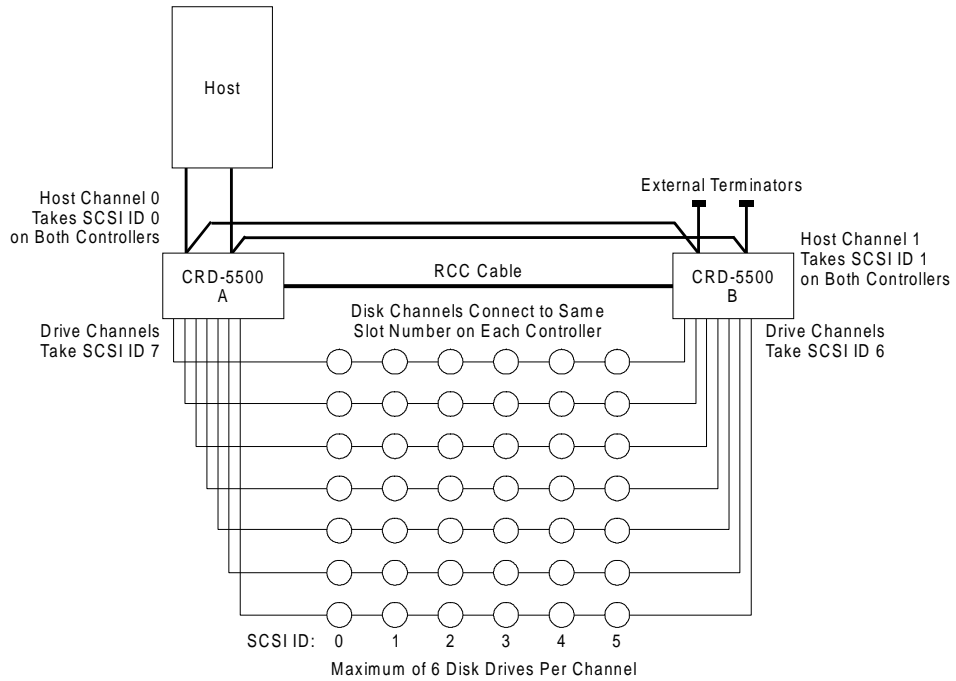

Figure 6-5: Single-host cabling diagram (example 2)

One host SCSI bus runs to host channel 0 on controller A, then to host channel 0 on controller B. The other host SCSI bus runs to host channel 1 on controller A, then to host channel 1 on controller B. Both hosts are then terminated with external terminators (the other end of each bus is terminated at the host adapter).



6.6 Multiple-Host Configuration Examples

NOTE

These examples are intended to illustrate the general principles of configuring a redundant controller system, and should not be construed to imply that they are the preferred or recommended methods. There are many ways to configure such a redundant controller system. For instance, many users will wish to run disk channel cables from one controller to the other and then to the disk drives.

In the configuration diagrammed in Figure 6-6, both CRD-5500 controllers have two host channels. Host computer 0 is connected to host channel 0 on both controllers, and host computer 1 is connected to host channel 1 on both controllers. By using the host channel status settings listed in Table 6-2, and by using host LUN mapping to map RAID sets to particular host channels, you may isolate I/O activity for host computer 0 on controller A and I/O activity for host computer 1 on controller B, while still benefiting from redundancy.

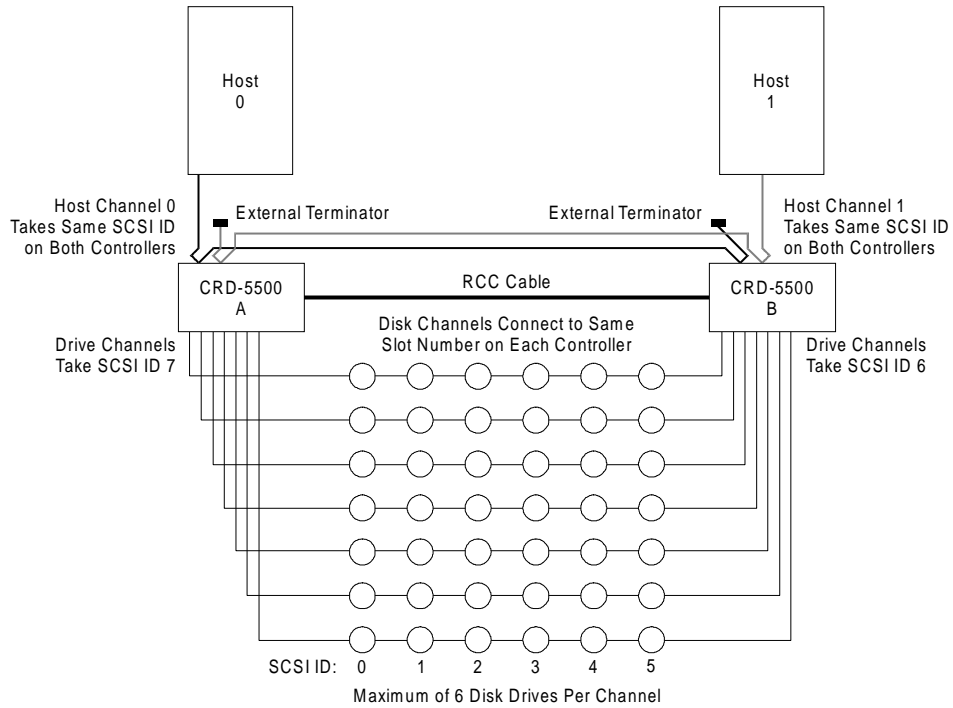

Figure 6-6: Multiple-host cabling diagram (example 1)



Table 6-2: Configuration for Multiple-Host System (example 1)

Controller/Host Channel	SCSI ID	Status
A/0	0	Active
A/1	0	Passive
B/0	0	Passive
B/1	0	Active

In the configuration diagrammed in Figure 6-7, both CRD-5500 controllers have four host channels. Host computer 0 is connected to host channels 0 and 1 on both controllers, and host computer 1 is connected to host channels 2 and 3 on both controllers. This configuration offers greater throughput than the one shown in Figure 6-6. By using the host channel status settings listed in Table 6-3, and by using host LUN mapping to map RAID sets to particular host channels, you may isolate I/O activity for host computer 0 on controller A and I/O activity for host computer 1 on controller B, while still benefiting from redundancy.

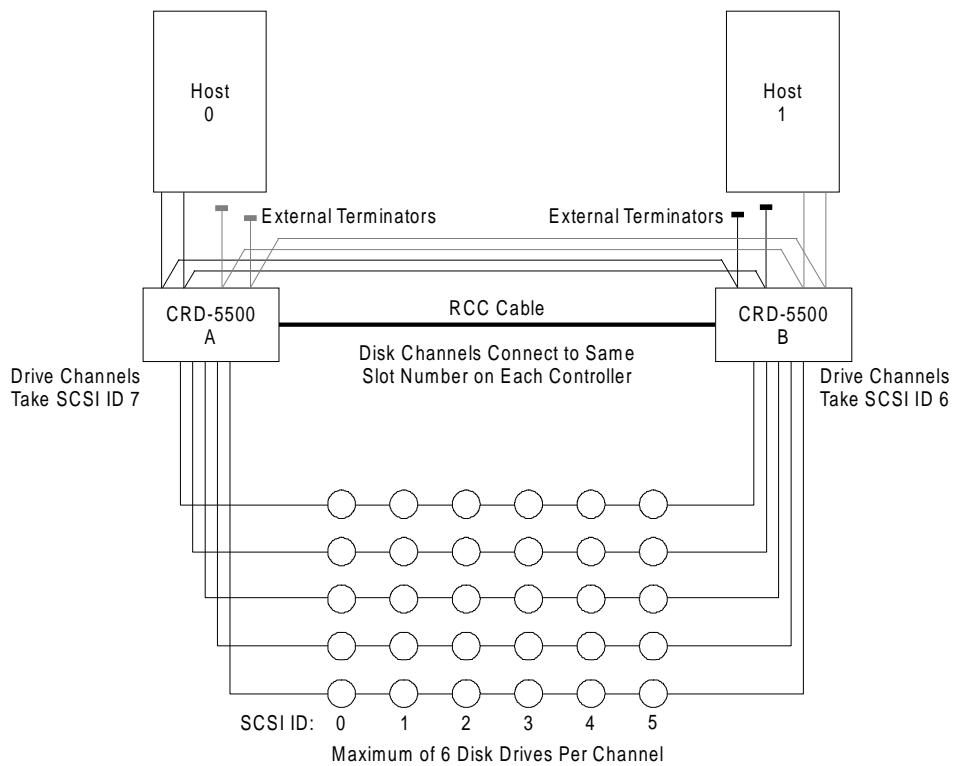

Figure 6-7: Multiple-host cabling diagram (example 2)

Table 6-3: Configuration for Multiple-Host System (example 2)

Controller/Host Channel	SCSI ID	Status
A/0	0	Active
A/1	1	Passive
A/2	2	Active



A/3	3	Passive
B/0	0	Passive
B/1	1	Active
B/2	2	Passive
B/3	3	Active



The configuration diagrammed in Figure 6-8 supports a dual-hosted environment (e.g., VMS/AXP SCSI cluster, Windows NT cluster, TruCluster for DEC UNIX). It requires only one SCSI cable and one SCSI controller per host system. Host channels, SCSI IDs and status for this configuration are shown in Table 6-4.

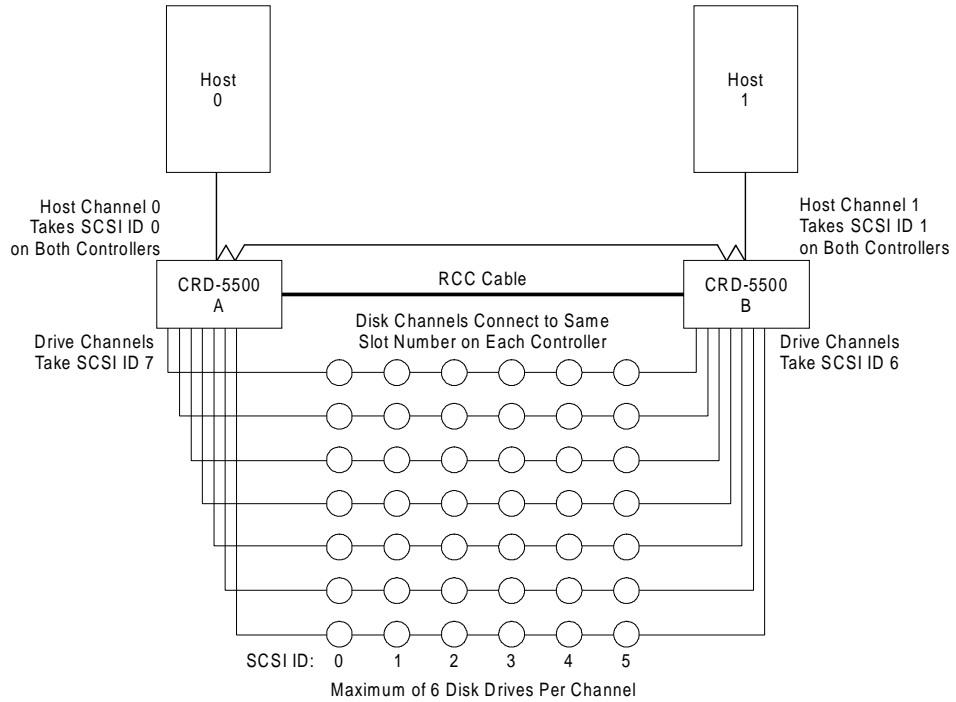

Figure 6-8: Multiple-host cabling diagram (example 3)

Table 6-4: Configuration for Multiple-Host System (example 3)

Controller/Host Channel	SCSI ID	Status
A/0	0	Active
A/1	1	Passive
B/0	0	Passive
B/1	1	Active



The configuration diagrammed in Figure 6-9 also supports a dual-ported host environment (e.g., VMS/AXP SCSI cluster, Windows NT cluster, TruCluster for DEC UNIX). Because it uses two SCSI cables, it has greater throughput than the configuration shown in Figure 6-8. Host channels, SCSI IDs and status for this configuration are shown in Table 6-5.

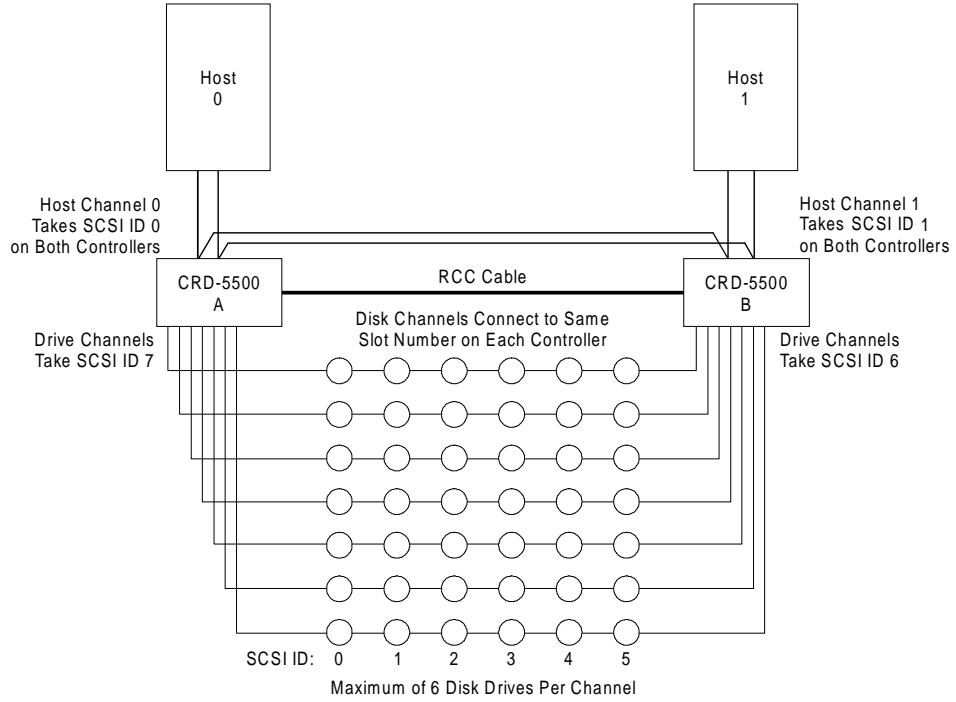

Figure 6-9: Multiple-host cabling diagram (example 4)

Table 6-5: Configuration for Multiple-Host System (example 4)

Controller/Host Channel	SCSI ID	Status
A/0	0	Active
A/1	0	Passive
B/0	0	Passive
B/1	0	Active



The configuration diagrammed in Figure 6-10 also supports a dual-ported host environment (e.g., VMS/AXP SCSI cluster, Windows NT cluster, TruCluster for DEC UNIX). Because it uses four SCSI cables, it has greater throughput than the configuration shown in Figure 6-9. Host channels, SCSI IDs and status for this configuration are shown in Table 6-6.

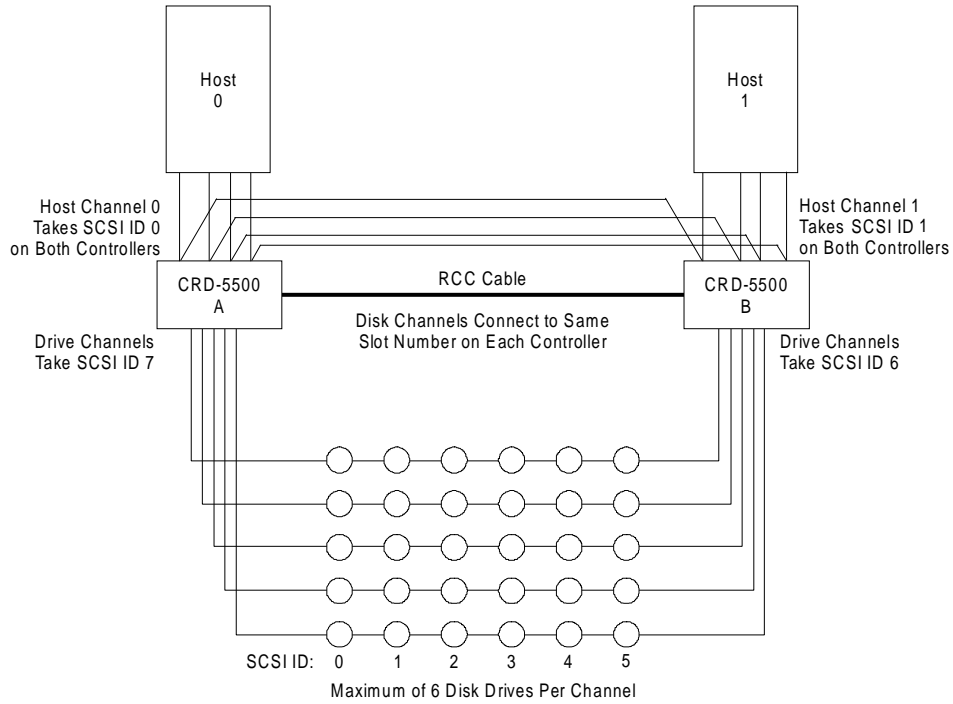

Figure 6-10: Multiple-host cabling diagram (example 5)

Table 6-6: Configuration for Multiple-Host System (example 5)

Controller/Host Channel	SCSI ID	Status
A/0	0	Active
A/1	0	Passive
A/2	0	Active
A/3	0	Passive
B/0	0	Passive
B/1	0	Active
B/2	0	Passive
B/3	0	Active



6.7 Configuring the Redundant Controller Mode

After setting the hardware up as described above, the two controllers can be powered on. After running self test, they will automatically attempt to bind themselves into a redundant controller set. The first attempt will normally fail because various setup parameters first need to be configured.

NOTE

The following screens depict a configuration example for one controller in a redundant pair. Unless otherwise directed, you must perform each step on the other controller as well.

- 1 Go to the MAIN MENU and select *Setup Parameters*.

```
Right Raid Unit Monitor Utility      07-29-96
MAIN MENU                          15:32:48
```

```
+-----+
| RAID Set Information |
| Setup Parameters    |
+-----+
| Host Parameters     |
| System Parameters  |
| Host LUN Mapping    |
| Disk Parameters    |
| Channel Settings   |
| Rdnt Ctrlr Parameters |
+-----+
```

UP ARROW: CURSOR UP | DOWN ARROW: CURSOR DOWN | ENTER: SELECT | CTRL-Z: EXIT |

- 2 Select *Rdnt Ctrlr Parameters* (Redundant Controller Parameters). The following screen will appear:

```
Right Raid Unit Monitor Utility      07-29-96
REDUNDANT CONTROLLER PARAMETERS    15:39:26
```

Parameter	Value
Controller Name	# 1
Host I/O Channel 0	Active
Host I/O Channel 1	Passive

ARROW KEYS: MOVE CURSOR | ENTER: SELECT | CTRL-Z: EXIT |

- 3 Perform the following actions:

- A** Enter a name or number for each controller. This name will be used in other screens to identify the controller. It is a good idea to select a descriptive name to help you distinguish between the controllers. Names reflecting the physical location of the controller, such as "Top," "Bottom," "Left," or "Right," may be helpful.
- B** Set the status for each of the host I/O channels. When you restart the controllers to complete the configuration, the host channel status settings on the second controller to finish booting up will automatically be the opposite of the settings on the first controller. In other words, if the first controller boots up with host channel 0 as active and host channel 1 as passive, then the second controller will automatically set its host channel 0 as passive and host channel 1 as active.

When finished, press CTRL-Z to return to the MAIN MENU.





4 Select *Setup Parameters*.

```
Right Raid Unit Monitor Utility      07-29-96
MAIN MENU                            15:40:28
```

```
+-----+
| RAID Set Information |
| Setup Parameters   |
+-----+
| Host Parameters    |
| System Parameters  |
| Host LUN Mapping   |
| Disk Parameters    |
| Channel Settings   |
| Rdnt Ctrlr Parameters |
+-----+
```

UP ARROW: CURSOR UP | DOWN ARROW: CURSOR DOWN | ENTER: SELECT | CTRL-Z: EXIT |

5 Select *Disk Parameters*.

```
Right Raid Unit Monitor Utility      07-29-96
DISK PARAMETERS                       15:43:10
```

Channel	Termination	Module Description
2	Full	16-Bit Single-Ended
3	Full	16-Bit Single-Ended

ARROW KEYS: MOVE CURSOR | ENTER: SELECT | CTRL-Z: EXIT |

6 Select the proper SCSI termination for each disk channel.

- A** If the relevant controller is at the end of the SCSI bus, set termination to FULL, unless you are using external terminators on the disk channel buses.
- B** If the relevant controller is in the middle of the SCSI bus, set termination to OFF.
- C** If you are using 16-bit “wide” SCSI modules, you may also select PARTIAL termination. In which case, the module will terminate the upper 8 bits of the bus only. Use this option if you are mixing wide and narrow drives on the same bus, and the I/O module is in between a wide drive and a narrow drive.

When finished, press CTRL-Z to return to the MAIN MENU.

NOTE

The above applies only for the 5540 fast/wide single-ended module. For the 5560 fast/wide/differential module, termination cannot be selected via the utility menu (it will always show “NA”) and must be supplied via an external differential terminator.

7 Select *Setup Parameters*.



Right Raid Unit Monitor Utility 07-29-96
MAIN MENU 15:44:02

```

+-----+
| RAID Set Information |
| Setup Parameters   |
+-----+
| Host Parameters    |
| System Parameters  |
| Host LUN Mapping   |
| Disk Parameters    |
| Channel Settings   |
| Rdnt Ctrlr Parameters |
+-----+

```

UP ARROW: CURSOR UP | DOWN ARROW: CURSOR DOWN | ENTER: SELECT | CTRL-Z: EXIT |

8 Select *Host Parameters*.

Right Raid Unit Monitor Utility 07-29-96
HOST PARAMETERS 15:51:17

Parameter	Channel 0	Channel 1
SCSI ID	0	1
Tag Queuing	ON	ON
Sync. Mode	ON	ON
Sync. Rate	20 MB/SEC	20 MB/SEC
Bus Width	16 Bit	16 Bit
Termination	FULL	FULL

ARROW KEYS: MOVE CURSOR | ENTER: SELECT | CTRL-Z: EXIT |

NOTE

The controller will not let you configure a passive host module.

- 9** Configure each active host module as required. Each host channel configuration must dovetail with its counterpart on the other controller. When two controllers boot up and attempt to form a redundant pair, the first controller to boot up will identify its active host channels and instruct the other controller to configure its counterpart host channels to match those on the first. Similarly, when the second controller boots up, it will copy the configuration information for its active host channels to the other controller. When finished, press CTRL-Z to return to the MAIN MENU.

10 Select *Setup Parameters*.

Right Raid Unit Monitor Utility 07-29-96
MAIN MENU 15:44:02

```

+-----+
| RAID Set Information |
| Setup Parameters   |
+-----+
| Host Parameters    |
| System Parameters  |
| Host LUN Mapping   |
| Disk Parameters    |
| Channel Settings   |
| Rdnt Ctrlr Parameters |
+-----+

```

UP ARROW: CURSOR UP | DOWN ARROW: CURSOR DOWN | ENTER: SELECT | CTRL-Z: EXIT |

11 Select *Host LUN Mapping*.



```

Right Raid Unit Monitor Utility          07-29-96
HOST LUN MAPPING                        15:46:22
Channel 0
-----+-----+-----+-----+
| Host LUN | Redundancy Group | | Host LUN | Redundancy Group |
+-----+-----+-----+-----+
| 0        | 0                | | 16       | -                |
| 1        | 1                | | 17       | -                |
| 2        | 2                | | 18       | -                |
| 3        | 3                | | 19       | -                |
| 4        | -                | | 20       | -                |
| 5        | -                | | 21       | -                |
| 6        | -                | | 22       | -                |
| 7        | -                | | 23       | -                |
| 8        | -                | | 24       | -                |
| 9        | -                | | 25       | -                |
| 10       | -                | | 26       | -                |
| 11       | -                | | 27       | -                |
| 12       | -                | | 28       | -                |
| 13       | -                | | 29       | -                |
| 14       | -                | | 30       | -                |
| 15       | -                | | 31       | -                |
+-----+-----+-----+-----+

```

N: NEXT CH | P: PREV CH | ENTER: SELECT | C: CLEAR | D: DEFAULT | CTRL-Z: EXIT

- 12** If you have more than one host channel in each controller, you may balance I/O activity between each controller with the Host LUN Mapping screen. Host LUN mapping must be set up in such a way that partitioned RAID sets are not shared between controllers. Select an active host channel with the N and P keys. (The controller will not let you set LUN mapping for a passive channel.) Use the C key to clear the screen if you wish to start with a blank slate. Then, match the redundancy groups that you wish this host channel to handle to a logical unit number (LUN). This is the LUN that the host will use to address the redundancy group. A dash (-) indicates that the LUN is not mapped to any redundancy group.

When you have finished with one active host channel, switch to the other controller's Host LUN Mapping screen, select an active host channel, and assign LUNs to other redundancy groups not mapped to the other controller's active host channel or channels.

For example, you might map redundancy groups 4 through 7 to LUNs 0 through 3 on host channel 1 of the second controller, as follows.

```

Left Raid Unit Monitor Utility          07-29-96
HOST LUN MAPPING                        15:46:22
Channel 1
-----+-----+-----+-----+
| Host LUN | Redundancy Group | | Host LUN | Redundancy Group |
+-----+-----+-----+-----+
| 0        | 4                | | 16       | -                |
| 1        | 5                | | 17       | -                |
| 2        | 6                | | 18       | -                |
| 3        | 7                | | 19       | -                |
| 4        | -                | | 20       | -                |
| 5        | -                | | 21       | -                |
| 6        | -                | | 22       | -                |
| 7        | -                | | 23       | -                |
| 8        | -                | | 24       | -                |
| 9        | -                | | 25       | -                |
| 10       | -                | | 26       | -                |
| 11       | -                | | 27       | -                |
| 12       | -                | | 28       | -                |
| 13       | -                | | 29       | -                |
| 14       | -                | | 30       | -                |
| 15       | -                | | 31       | -                |
+-----+-----+-----+-----+

```

N: NEXT CH | P: PREV CH | ENTER: SELECT | C: CLEAR | D: DEFAULT | CTRL-Z: EXIT

In this example, the host would access redundancy groups 0 through 3 through host channel 0 of the "Right Raid" controller and redundancy groups 4 through 7 through host channel 1 of the "Left Raid" controller.

When finished, press CTRL-Z to return to the MAIN MENU.



NOTE

Host LUN mapping determines which redundancy group belongs to which controller. The CREATE and REBUILD commands will not allow use of a redundancy group that does not belong to your controller.

13 Restart both controllers. The two controllers should automatically bind into a redundant controller set. When this is done, enter the MAIN MENU on both monitors.

14 Select *Setup Parameters*.

```
Right Raid Unit Monitor Utility      07-29-96
MAIN MENU                            15:47:01
```

```
+-----+
| RAID Set Information |
| Setup Parameters    |
+-----+
| Host Parameters     |
| System Parameters   |
| Host LUN Mapping    |
| Disk Parameters     |
| Channel Settings    |
+-----+
| Rdnt Ctrlr Parameters |
+-----+
```

```
UP ARROW: CURSOR UP | DOWN ARROW: CURSOR DOWN | ENTER: SELECT | CTRL-Z: EXIT |
```



15 Select Rdnt Ctrlr Parameters.

```
Right Raid Unit Monitor Utility      07-29-96
REDUNDANT CONTROLLER PARAMETERS    15:47:07
```

Parameter	Value
Controller Name	1
Host I/O Channel 0	Active
Host I/O Channel 1	Passive

ARROW KEYS: MOVE CURSOR | ENTER: SELECT | CTRL-Z: EXIT |

16 Verify the parameters on both monitors. If they are in order, press CTRL-Z to return to the MAIN MENU.

17 Select System Information.

```
Right Raid Unit Monitor Utility      07-29-96
MAIN MENU                            15:47:16
```

RAID Set Information
Setup Parameters
System Information
I/O Statistics
Free Lists Statistics
Manufacturing Information
Environmental Status
I/O Process Information
Rdnt Ctrlr Information

UP ARROW: CURSOR UP | DOWN ARROW: CURSOR DOWN | ENTER: SELECT | CTRL-Z: EXIT |

18 Select Rdnt Ctrlr Information.

```
Right Raid Unit Monitor Utility      07-29-96
REDUNDANT CONTROLLER INFORMATION    15:48:20
```

Controller Name	LEFT	RIGHT
Disk Channel ID	6	7
Host I/O Channel	1	0
Active RAID Set Numbers	4 5 6 7	0 1 2 3
Last Msg Sent	Heartbeat Count: 45 (Ch 1)	Heartbeat Count: 45 (Ch 1)
Status	Bind Successfully Completed: 07-29-96 15:26:00	

CTRL-Z: EXIT |

19 Verify the following:

- A** The STATUS indicates that the bind was successfully completed.
- B** The disk channel IDs and host I/O channels are separate and distinct for each controller.
- C** Active RAID set numbers are not duplicated between the two controllers.
- D** Heartbeat messages are being sent and received between the two controllers.



This concludes the configuration procedure for redundant controller mode operation.

6.8 Restart After Switchover

NOTE

To avoid disrupting SCSI bus activity when replacing a failed CRD-5500 unit in a redundant controller configuration, both units **MUST** use external termination for both the host and disk controllers.

- 1 Pause or stop all host I/O activity to the CRD-5500 redundant controller subsystem.
 - 2 Shut down the surviving CRD-5500 controller (either from the main menu or the front panel). This is especially important, to ensure that data in the cache is written to disk. **IF THIS STEP IS NOT PERFORMED AND THE BATTERY IS REMOVED, ALL DATA IN THE CACHE WILL BE LOST.**
 - 3 Power off both CRD-5500 controllers.
 - 4 Remove battery power to both CRD-5500 controllers. Ensure that enough time is allowed for the cache memory to fully discharge before continuing.
-

NOTE

If a failed CRD-5500 is only being "power-cycled", perform steps 1 through 4. Then skip to steps 10 through 14.

- 5 Swap the failed CRD-5500 with another identical controller. The unit being swapped in must be configured in exactly the same way (same number and type of host and disk channel modules, same amount of cache memory etc.).
- 6 Re-establish the system: reconnect terminations, battery power connections, SCSI cables and the RCC cable.
- 7 Power on both CRD-5500 controllers.
- 8 Reconfigure all controller parameters on the replacement unit for each sub-menu choice under *Setup Parameters* (i.e., *Host Parameters*, *System Parameters*, *Host LUN Mapping*, *Disk Parameters*, *Channel Settings and Redundant Controller Parameters*).
- 9 Shut down both CRD-5500 controllers (either from the main menu or the front panel).



- 10 Power cycle both CRD-5500 controllers.
- 11 Go to the *RAID Set Information* screen. Verify that all RAID sets are visible.
- 12 Verify that all controller parameters are correct on both units by checking each sub-menu choice under *Setup Parameters* (i.e., *Host Parameters*, *System Parameters*, *Host LUN Mapping*, *Disk Parameters*, *Channel Settings* and *Redundant Controller Parameters*).
- 13 Go to the *Redundant Controller Information* screen. Verify that the two CRD-5500 controllers have successfully bound. Ensure that all RAID sets are active on the host channels of the correct controller (in accordance with the *Host LUN Mapping* and *Redundant Controller Parameters* settings on both controllers).
- 14 Resume host I/O activity to the CRD-5500 redundant controller subsystem.

This concludes the procedure for redundant controller restart after switchover.



This page left blank intentionally



A Warranty

BASIC WARRANTY—CMD warrants this product to be free from defect in material and workmanship for a period of three years from the date of shipment. During this period, if the customer experiences difficulties with the product and is unable to resolve the problem via phone with CMD Technical Support, a Return Material Authorization (RMA) will be issued. Following receipt of an RMA, the Purchaser is responsible for returning the product to CMD, freight prepaid. CMD, upon verification of warranty, will repair or replace at its option the part in question, and will then return the product to the Purchaser, freight prepaid.

GENERAL TERMS—The above warranties shall not apply to expendable components such as fuses, bulbs, and the like, nor to connectors, adapters, and other items not a part of the basic product. CMD shall have no obligation to make repairs or to cause replacement required through normal wear and tear or necessitated in whole or in part by catastrophe, fault or negligence of the user, improper or unauthorized use of the product, or use of the product in such a manner for which it was not designed, or by causes external to the product, such as, but not limited to shipping damage, power failure or air conditioning. CMD's sole obligation hereunder shall be to repair or replace any defective product, and, unless stated, pay return transportation costs. Purchaser shall provide labor for removal of the defective product, shipping charges for return to CMD and installation of its replacement. On-site services are not a part of this warranty. Above warranties are subject to change without notice.

RETURNED MATERIAL—Warranty claims must be received by CMD within the applicable warranty period. A replaced product, or part thereof, shall become the property of CMD and shall be returned to CMD at Purchaser's expense.

All returned material must be accompanied by a Return Materials Authorization (RMA) number assigned by CMD. To obtain an RMA number, call CMD at (714) 454-0800. CMD Sales personnel must be consulted for authorization of returned goods for credit and/or evaluation.

THE EXPRESSED WARRANTIES SET FORTH IN THIS AGREEMENT ARE IN LIEU OF ALL OTHER WARRANTIES, EXPRESSED OR IMPLIED, INCLUDING WITHOUT LIMITATION, ANY WARRANTIES OF MERCHANTABILITY OR FITNESS FOR A PARTICULAR PURPOSE, AND ALL SUCH OTHER WARRANTIES ARE HEREBY DISCLAIMED AND EXCLUDED BY CMD. THESE STANDARD EXPRESS WARRANTIES ARE IN LIEU OF ALL OBLIGATIONS OR LIABILITIES ON THE PART OF CMD FOR DAMAGES, INCLUDING BUT NOT LIMITED TO SPECIAL, INDIRECT OR CONSEQUENTIAL DAMAGES ARISING OUT OF OR IN CONNECTION WITH THE USE OR PERFORMANCE OF THE PRODUCT.



Return and Repair Policy

Return for Repair

CMD RAID Chassis, Original CMD Chassis Components, and CMD Controller

In-Warranty (Less than 3 years)

Defective products will be repaired or replaced at CMD's option and returned to the customer within 15 working days from the date of receipt at CMD. CMD does not warranty disk or other peripheral devices installed in or attached to CMD RAID chassis or controllers.

CMD also offers two in-warranty 24 hour expediting services:

24 Hour Turnaround Loaner Service: Under this policy, CMD will ship a loaner in 24 hours during regular working days to the customer for a fee. Upon receiving the loaner, customer must return the defective product to CMD within seven (7) days for repair. CMD will repair the defective product and return the product to the customer. Customer must then return the loaner in seven (7) days after the receipt of the repaired product. Approval for loaner service is based on credit verification. The customer is responsible for the cost of shipping the loaner.

24 Hour Turnaround Swap Service: Within the first six (6) months of the warranty, CMD, at its own option, offers a 24 hour turnaround swap service for defective or dead-on-arrival products. CMD will ship the same model of the product to the customer within 24 hours during working days in exchange for the defective product. CMD will swap with a new product if product is not functional upon arrival. For all other cases, swap will occur with either a new or refurbished product for a fee. CMD does not offer swap services for products that are purchased more than six months from the date of shipment. Customer is responsible for returning the defective product to CMD within seven (7) days after receipt of the swapped product.

The remaining warranty period shall apply to the repaired or swapped product.

Out-of-Warranty (more than 3 years)

CMD will repair and return defective controllers within 15 working days from the date that CMD receives the controller.



Shipping Charges

The following shipping charges apply to all REPAIR, SWAP, LOANER, and UPGRADE UNITS.

In-Warranty

Domestic Freight from CMD to customer is to be paid by CMD; freight from customer to CMD is to be paid by customer.

International Same as above, except customer is responsible for payment of all customs duties and broker fees.

Out-of Warranty

Domestic All fees are to be paid by customer.

International All fees are to be paid by customer (including custom duty and broker fees).



This page left blank intentionally.



Index

- Alarm, 2-6
 - silencing, 2-7, 5-1
- Bus width, 4-3
- Caching
 - write back, 1-4
 - write gathering, 1-4
 - write on top, 1-4
- Channels
 - host/disk configuration, 3-1, 4-5
 - settings, 3-1, 4-5
- Chunk size, 4-10
- CRD-5000
 - upgrading from, 1-5, 1-11
- Create RAID set, 4-8
 - rate, 4-4
- Cylinders reported, 2-3
- Date stamp, 4-4
- Disk drives
 - number supported, 2-3
 - specifications, 2-3
- Drive Failures, 3-7, 4-12
- Drive Info, 4-9, 4-13
- Event log, 4-18
- Event loo
 - clearing, 4-18
 - types of events, 4-20
- Failures
 - recovering from, 3-7
- Fan
 - reconnecting, 2-8
- Firmware
 - downloading to drives, 4-17
- Front panel display
 - tests, 5-1
- Geometry for drives, 2-3
- Global spares, 4-13
- Heads reported, 2-3
- Host LUN mapping, 4-5
- Host parameters, 2-4, 3-2, 4-3
 - restarting controller, 4-16
- I/O modules
 - configuring, 3-1, 4-5
- I/O process information, 4-7
- Information
 - RAID set, 4-1
- JBOD, 1-10, 4-8
- LUNs
 - mapping, 4-5, 6-14
- Mapping LUNs, 4-5, 6-14
- Operating environment, 4-7
- Partitioning, 3-5, 4-9
- Passwords, 4-4
- RAID 0, 1-5–1-6
- RAID 0+1, 1-7–1-8
- RAID 1, 1-6–1-7
- RAID 4, 1-8–1-9
- RAID 5, 1-9–1-11
- RAID Set
 - creating, 3-3, 3-5
 - deleting, 4-11
 - rebuilding, 4-12
- RAID set information, 4-1
- RAID sets
 - creating, 4-8
 - status, 5-1
- RCC Cable. *See* Redundant Controller Communication (RCC) Cable
 - Assembly Information. *See* Redundant Controller Communication (RCC) Cable: Assembly Information
 - Connection. *See* Redundant Controller Communication (RCC) Cable: Connection
- Read long, 2-3
- Read-ahead
 - limiting, 4-5
 - turning on and off, 4-4
- Rebuilding RAID groups, 4-12
 - concurrent, 4-13
 - rate, 4-4
 - Rebuild/Create Status screen, 3-8
- Rebuilding RAID sets, 3-7
- Redundancy group, 4-10
- Redundant Controller, 6-1
 - Configuration, 6-12
 - Configuration Examples
 - Multiple-Host, 6-7
 - Single-Host, 6-5
- Requirements, 6-1
 - Firmware, 6-1
 - Hardware, 6-1



- SIMM Cache, 6-1
- Restart, 6-17
- SIMM Installation, 6-2
- Redundant Controller Communication (RCC)
 - Cable, 6-1
 - Assembly information, 6-4
 - Connection, 6-3
- Restart, 4-3, 4-6
- Scanning the SCSI bus, 4-13
- SCSI
 - ID, 4-3
 - read/write long, 2-3
 - scanning bus, 4-9, 4-13
 - SCSI IDs, 2-4
 - termination, 2-4
- Sectors reported, 2-3
- Shutdown, 4-16
- Spares, 4-13
 - adding, 3-6
 - global, 3-7, 4-13
 - hot, 4-13
 - warm, 4-13
- Spin up
 - accommodating slower drives, 4-5
- Synchronous transfer rate, 4-3
- Synchronous transfers, 4-3
- System code
 - obtaining, 4-14
- System shutdown, 4-16
- Tag queuing, 4-3
- Temperature, 4-7
- Termination, 4-3
- Time stamp, 4-4
- Troubleshooting, 4-18
- UPS, 4-4
- Validation delay, 4-5
- Voltage levels, 4-7
- Warranty, A-1
- Write long, 2-3