

UNITED STATES PATENT AND TRADEMARK OFFICE

---

BEFORE THE PATENT TRIAL AND APPEAL BOARD

---

FORD MOTOR COMPANY,  
Petitioner,

v.

PAICE LLC & THE ABELL FOUNDATION, INC.,  
Patent Owner.

---

Case IPR2014-00568  
Patent 7,455,134 B2

---

Before SALLY C. MEDLEY, KALYAN K. DESHPANDE, and  
CARL M. DeFRANCO, *Administrative Patent Judges*.

MEDLEY, *Administrative Patent Judge*.

DECISION  
Denying Institution of *Inter Partes* Review  
*37 C.F.R. § 42.108*

## I. INTRODUCTION

Petitioner, Ford Motor Company, filed a Petition requesting an *inter partes* review of claims 1–3, 5, 6, 19, 20, 26, 27, 40, 58, and 62 of U.S. Patent No. 7,455,134 B2 (Ex. 1001, “the ’134 patent”). Paper 1 (“Pet.”). Patent Owner, Paice LLC & The Abell Foundation, Inc., filed an unredacted and redacted Preliminary Response. Papers 7 and 8 (“Prelim. Resp.”).<sup>1</sup> Patent Owner also filed a Motion to Seal. Paper 9 (“Mot. to Seal.”). We have jurisdiction under 35 U.S.C. § 314(a), which provides that an *inter partes* review may not be instituted “unless . . . the information presented in the petition . . . shows that there is a reasonable likelihood that the petitioner would prevail with respect to at least 1 of the claims challenged in the petition.”

Upon consideration of the Petition and the Preliminary Response, we conclude that there is not a reasonable likelihood that Petitioner would prevail in challenging any of claims 1–3, 5, 6, 19, 20, 26, 27, 40, 58, and 62 as unpatentable. Accordingly, pursuant to 35 U.S.C. § 314(a), we do not authorize an *inter partes* review to be instituted as to claims 1–3, 5, 6, 19, 20, 26, 27, 40, 58, and 62 of the ’134 patent.

---

<sup>1</sup> Citations are to the Patent Owner redacted Preliminary Response (Paper 8, “Prelim. Resp.”). Patent Owner marked Paper 8 for “Parties and Board Only.” The paper will be made publicly available in due course.

A. Related Proceedings

The '134 patent is involved in *Paice, LLC et al. v. Ford Motor Company*, No. 1-14-cv-00492, filed on February 19, 2014, in the United States District Court for the District of Maryland. Pet. 2.

B. The '134 Patent (Ex. 1001)

The '134 patent describes a hybrid vehicle with an internal combustion engine, a traction motor, a starter motor, and a battery bank, all controlled by a microprocessor. Ex. 1001, Abs. Figure 4, reproduced below, shows a block diagram of a hybrid vehicle. *Id.* at Fig. 4.

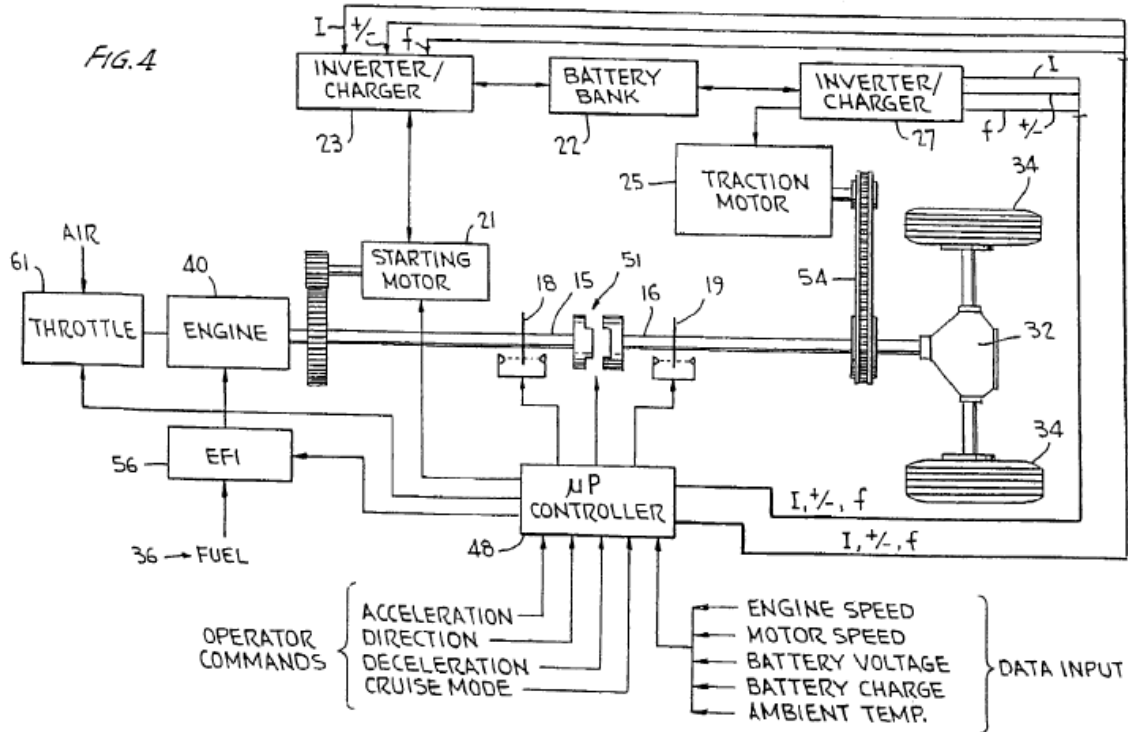

Figure 4 illustrates a block diagram of a hybrid vehicle.

The hybrid vehicle includes two wheels 34, operable to propel the vehicle, traction motor 25, starting motor 21, and engine 40 coupled to starting motor 21. *Id.* Inverter/charger 27 is coupled to traction motor 25 and inverter/charger 23 is coupled to starting motor 21. *Id.* Battery bank 22 is coupled to inverter/charger 23, as well as inverter/charger 27. Controller 48 controls the operation of engine 40 and motors 21 and 25. *Id.* The components of the vehicle “are to be sized so that the ratio between battery voltage under load to peak current is at least about 2.5, and preferably is at least 3.5 to 4:1.” *Id.* at 50:5–9.

### C. Claims

Petitioner challenges independent claim 1 and dependent claims 2, 3, 5, 6, 19, 20, 26, 27, and 40, which depend directly from claim 1. Petitioner also challenges independent claim 58 and dependent claim 62, which depends directly from claim 58. Claim 1 reads:

1. A hybrid vehicle, comprising:
  - at least two wheels, operable to receive power to propel said hybrid vehicle;
  - a first alternating current (AC) electric motor, operable to provide power to said at least two wheels to propel said hybrid vehicle;
  - a second AC electric motor;
  - an engine coupled to said second electric motor, operable to provide power to said at least two wheels to propel the hybrid vehicle, and/or to said second electric motor to drive the second electric motor to generate electric power;
  - a first alternating current-direct current (AC-DC) converter having an AC side coupled to said first electric motor,

operable to accept AC or DC current and convert the current to DC or AC current respectively;

a second AC-DC converter coupled to said second electric motor, at least operable to accept AC current and convert the current to DC;

an electrical storage device coupled to a DC side of said AC-DC converters, wherein the electrical storage device is operable to store DC energy received from said AC-DC converters and provide DC energy to at least said first AC-DC converter for providing power to at least said first electric motor; and

a controller, operable to start and stop the engine to minimize fuel consumption;

wherein a ratio of maximum DC voltage on the DC side of at least said first AC-DC converter coupled to said first electric motor to current supplied from said electrical storage device to at least said first AC-DC converter, when maximum current is so supplied, is at least 2.5.

*Id.* at 56:43–57:7.

# Explore Litigation Insights

Docket Alarm provides insights to develop a more informed litigation strategy and the peace of mind of knowing you're on top of things.

## Real-Time Litigation Alerts



Keep your litigation team up-to-date with **real-time alerts** and advanced team management tools built for the enterprise, all while greatly reducing PACER spend.

Our comprehensive service means we can handle Federal, State, and Administrative courts across the country.

## Advanced Docket Research



With over 230 million records, Docket Alarm's cloud-native docket research platform finds what other services can't. Coverage includes Federal, State, plus PTAB, TTAB, ITC and NLRB decisions, all in one place.

Identify arguments that have been successful in the past with full text, pinpoint searching. Link to case law cited within any court document via Fastcase.

## Analytics At Your Fingertips



Learn what happened the last time a particular judge, opposing counsel or company faced cases similar to yours.

Advanced out-of-the-box PTAB and TTAB analytics are always at your fingertips.

## API

Docket Alarm offers a powerful API (application programming interface) to developers that want to integrate case filings into their apps.

## LAW FIRMS

Build custom dashboards for your attorneys and clients with live data direct from the court.

Automate many repetitive legal tasks like conflict checks, document management, and marketing.

## FINANCIAL INSTITUTIONS

Litigation and bankruptcy checks for companies and debtors.

## E-DISCOVERY AND LEGAL VENDORS

Sync your system to PACER to automate legal marketing.