



US007434974B2

(12) **United States Patent**
Parker

(10) **Patent No.:** **US 7,434,974 B2**
(45) **Date of Patent:** **Oct. 14, 2008**

(54) **LIGHT EMITTING PANEL ASSEMBLIES**

(75) Inventor: **Jeffery R. Parker**, Richfield, OH (US)

(73) Assignee: **Solid State Opto Limited** (VG)

(*) Notice: Subject to any disclaimer, the term of this patent is extended or adjusted under 35 U.S.C. 154(b) by 103 days.

(21) Appl. No.: **11/378,080**

(22) Filed: **Mar. 17, 2006**

(65) **Prior Publication Data**

US 2006/0158906 A1 Jul. 20, 2006

Related U.S. Application Data

(60) Continuation of application No. 10/784,527, filed on Feb. 23, 2004, now Pat. No. 7,160,015, which is a division of application No. 09/256,275, filed on Feb. 23, 1999, now Pat. No. 6,712,481, which is a continuation-in-part of application No. 08/778,089, filed on Jan. 2, 1997, now Pat. No. 6,079,838, which is a division of application No. 08/495,176, filed on Jun. 27, 1995, now Pat. No. 5,613,751.

(51) **Int. Cl.**

F21V 7/04 (2006.01)

(52) **U.S. Cl.** **362/612**; 362/619; 362/632; 362/634

(58) **Field of Classification Search** 362/231, 362/800, 27, 619, 613, 612, 620, 608, 609, 362/621, 600, 632, 634, 26

See application file for complete search history.

(56) **References Cited**

U.S. PATENT DOCUMENTS

- 2,480,178 A 8/1949 Zinberg
- 3,043,947 A 7/1962 Albinger, Jr.
- 3,241,256 A 3/1966 Viret et al.
- 3,328,570 A 6/1967 Balchunas
- 3,721,815 A 3/1973 Wall

- 3,752,947 A 8/1973 Baker et al.
- 3,760,179 A 9/1973 Addington, Jr.
- 3,781,537 A 12/1973 Ramsey
- 3,892,959 A 7/1975 Pulles
- 3,958,113 A 5/1976 Termohlen
- 4,043,636 A 8/1977 Eberhardt et al.
- 4,128,332 A 12/1978 Rowe
- 4,257,084 A 3/1981 Reynolds
- 4,277,817 A 7/1981 Hehr
- 4,323,951 A 4/1982 Pasco
- 4,373,282 A 2/1983 Wragg
- 4,446,508 A 5/1984 Kinzie
- 4,519,017 A 5/1985 Daniel
- 4,573,766 A 3/1986 Bournay, Jr. et al.

(Continued)

Primary Examiner—Thomas M Sember

(74) *Attorney, Agent, or Firm*—Renner, Otto, Boisselle & Sklar, LLP

(57) **ABSTRACT**

Light emitting panel assembly includes a light emitting panel member received in a cavity or recess in a tray or housing. The panel member has a pattern of light extracting deformities on or in at least one surface of the panel member to cause light received from at least one LED light source positioned near or against the light entrance surface of the panel member to be emitted from a light emitting surface of the panel member. The tray or housing acts as an end edge and/or side edge reflector for the panel member to reflect light that would otherwise exit the panel member through the end edge and/or side edge back into the panel member for causing additional light to be emitted from the panel member.

24 Claims, 4 Drawing Sheets

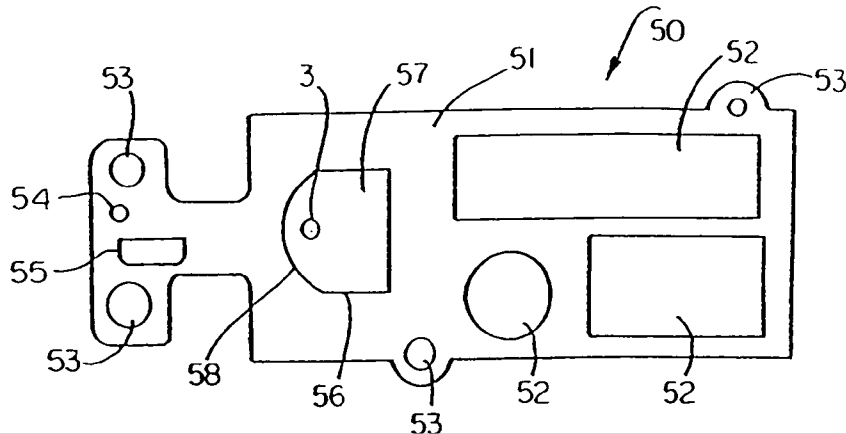

U.S. PATENT DOCUMENTS					
4,630,895	A	12/1986 Abdala, Jr. et al.	5,093,765	A	3/1992 Kashima et al.
4,648,690	A	3/1987 Ohe	5,134,549	A	7/1992 Yokoyama
4,677,531	A	6/1987 Szeles	5,136,480	A	8/1992 Pristash et al.
4,714,983	A	12/1987 Lang	5,136,483	A	8/1992 Schoniger et al.
4,729,067	A	3/1988 Ohe	5,184,888	A *	2/1993 Sakuma et al. 362/136
4,729,068	A	3/1988 Ohe	5,190,370	A	3/1993 Miller et al.
4,729,185	A	3/1988 Baba	5,207,493	A	5/1993 Murase et al.
4,751,615	A	6/1988 Abrams	5,243,506	A	9/1993 Whitehead
4,761,047	A	8/1988 Mori	5,262,928	A	11/1993 Kashima et al.
4,763,984	A	8/1988 Awai et al.	5,283,673	A	2/1994 Murase et al.
4,765,701	A	8/1988 Cheslak	5,339,179	A	8/1994 Rudisill et al.
4,791,540	A	12/1988 Dreyer, Jr. et al.	5,349,503	A	9/1994 Blonder et al.
4,802,066	A	1/1989 Mori	5,375,043	A	12/1994 Tokunaga
4,811,507	A	3/1989 Blanchet	5,377,084	A	12/1994 Kojima et al.
4,825,341	A	4/1989 Awai	5,390,085	A	2/1995 Mari-Roca et al.
4,890,201	A	12/1989 Joft	5,390,276	A *	2/1995 Tai et al. 385/146
4,909,604	A	3/1990 Kobayashi et al.	5,390,436	A	2/1995 Ashall
4,914,553	A	4/1990 Hamada et al.	5,394,308	A	2/1995 Watanabe et al.
4,929,062	A	5/1990 Guzik et al.	5,434,754	A *	7/1995 Li et al. 362/511
4,974,122	A	11/1990 Shaw	5,467,208	A	11/1995 Kokawa et al.
4,975,808	A	12/1990 Bond et al.	5,467,417	A	11/1995 Nakamura et al.
4,978,952	A	12/1990 Irwin	5,477,423	A	12/1995 Fredriksz et al.
4,985,809	A	1/1991 Matsui et al.	5,479,275	A	12/1995 Abileah
5,005,108	A	4/1991 Pristash et al.	5,485,291	A	1/1996 Qiao et al.
5,027,258	A	6/1991 Schoniger et al.	5,485,354	A *	1/1996 Ciupke et al. 362/619
5,050,046	A *	9/1991 Tada 362/26	5,600,455	A	2/1997 Ishikawa et al.
5,055,978	A	10/1991 Rogoff	5,719,649	A	2/1998 Shono et al.
5,070,431	A	12/1991 Kitazawa et al.	5,947,578	A	9/1999 Ayres
			5,999,685	A	12/1999 Goto et al.

* cited by examiner

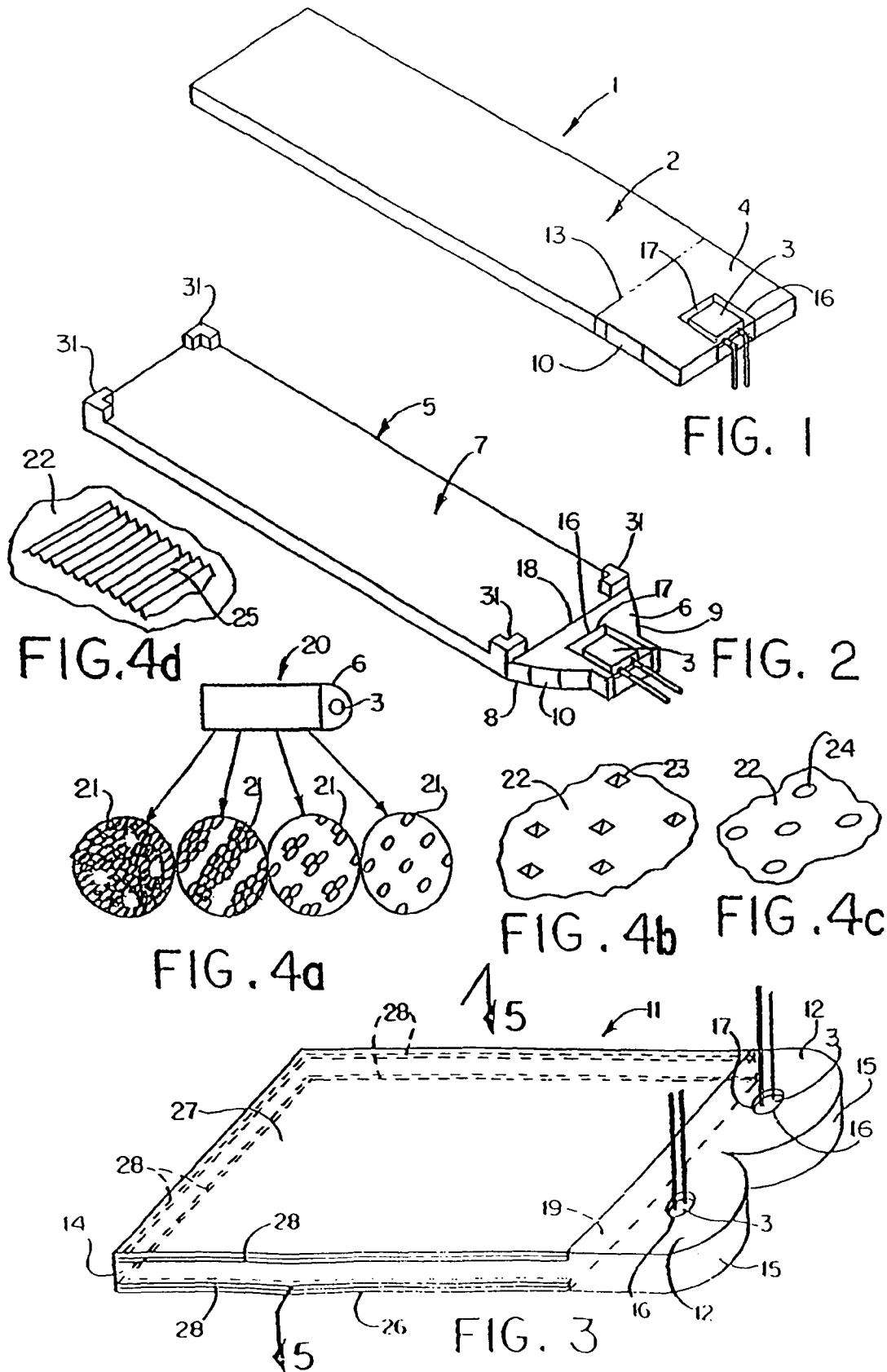

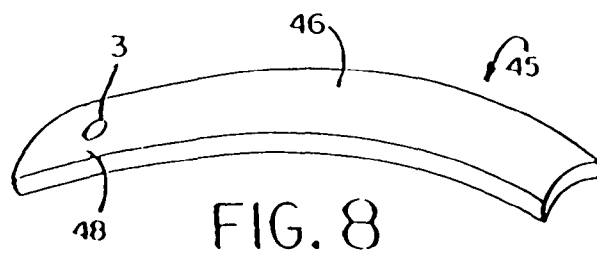
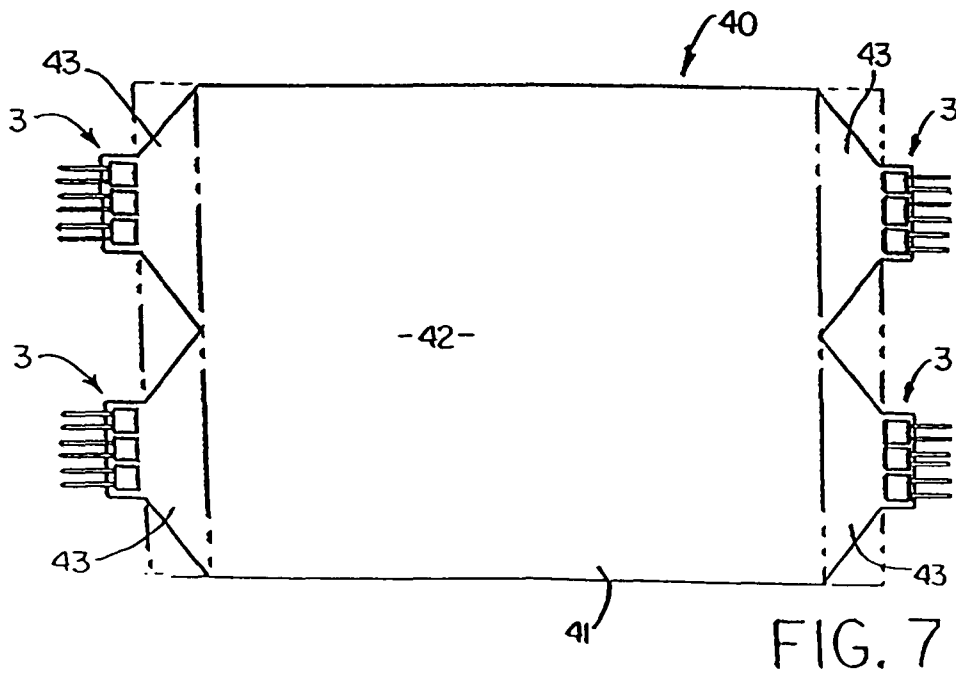
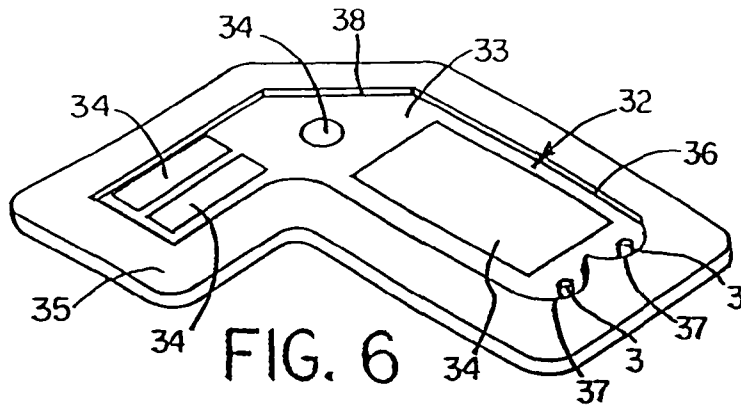
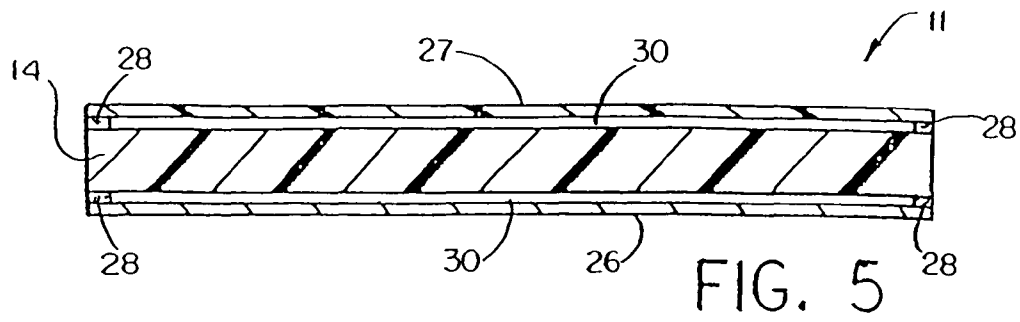

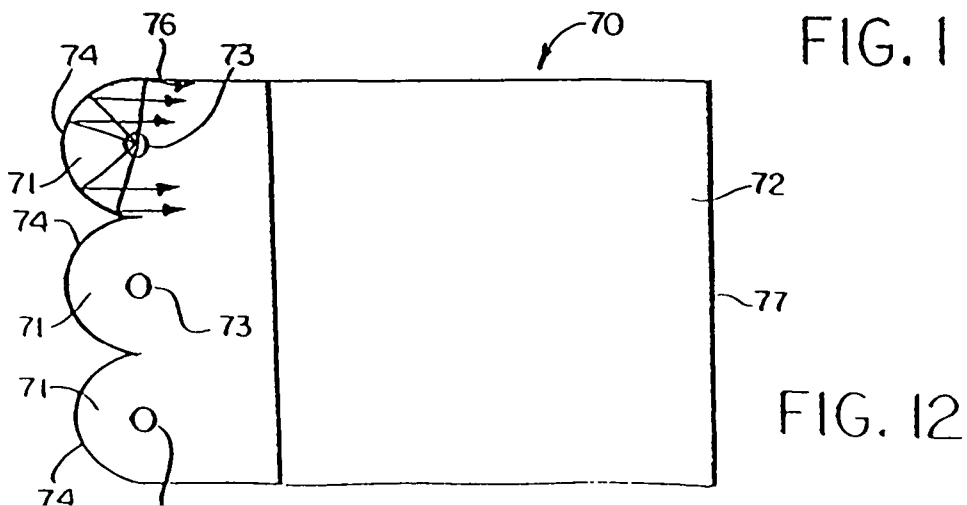
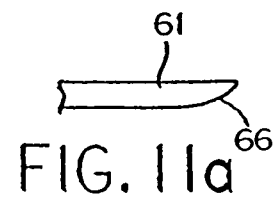
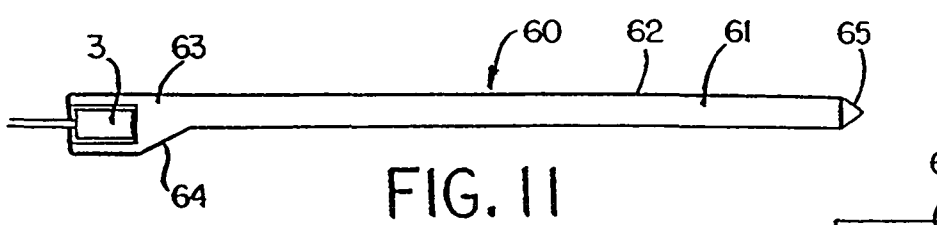
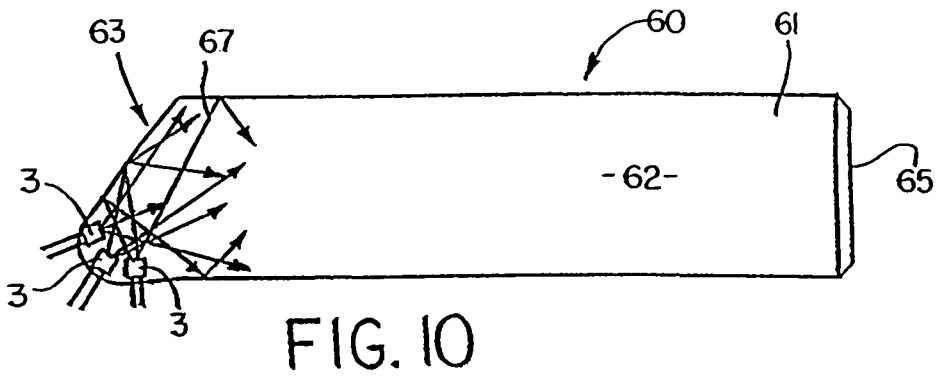
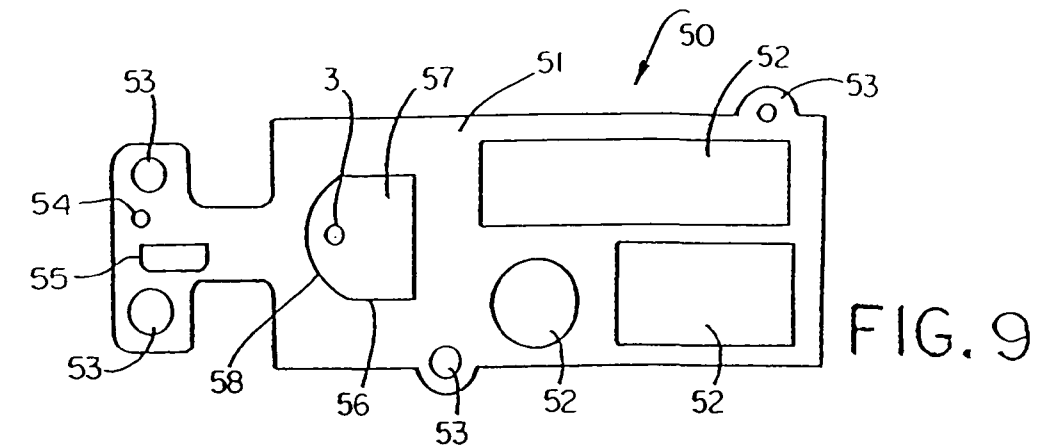

Explore Litigation Insights

Docket Alarm provides insights to develop a more informed litigation strategy and the peace of mind of knowing you're on top of things.

Real-Time Litigation Alerts



Keep your litigation team up-to-date with **real-time alerts** and advanced team management tools built for the enterprise, all while greatly reducing PACER spend.

Our comprehensive service means we can handle Federal, State, and Administrative courts across the country.

Advanced Docket Research



With over 230 million records, Docket Alarm's cloud-native docket research platform finds what other services can't. Coverage includes Federal, State, plus PTAB, TTAB, ITC and NLRB decisions, all in one place.

Identify arguments that have been successful in the past with full text, pinpoint searching. Link to case law cited within any court document via Fastcase.

Analytics At Your Fingertips



Learn what happened the last time a particular judge, opposing counsel or company faced cases similar to yours.

Advanced out-of-the-box PTAB and TTAB analytics are always at your fingertips.

API

Docket Alarm offers a powerful API (application programming interface) to developers that want to integrate case filings into their apps.

LAW FIRMS

Build custom dashboards for your attorneys and clients with live data direct from the court.

Automate many repetitive legal tasks like conflict checks, document management, and marketing.

FINANCIAL INSTITUTIONS

Litigation and bankruptcy checks for companies and debtors.

E-DISCOVERY AND LEGAL VENDORS

Sync your system to PACER to automate legal marketing.