

UNITED STATES PATENT AND TRADEMARK OFFICE

---

BEFORE THE PATENT TRIAL AND APPEAL BOARD

---

CORIAN T OPERATIONS, INC., CORIAN T (USA) INC.,  
CIENA CORPORATION, CISCO SYSTEMS, INC., and  
FUJITSU NETWORK COMMUNICATIONS, INC.,  
Petitioner,

v.

CAPELLA PHOTONICS, INC.,  
Patent Owner.

---

Case IPR2015-01971  
Patent RE42,678 E

---

Before JOSIAH C. COCKS, KALYAN K. DESHPANDE, and  
JAMES A. TARTAL, *Administrative Patent Judges*.

TARTAL, *Administrative Patent Judge*.

DECISION  
Instituting *Inter Partes* Review  
37 C.F.R. § 42.108  
Granting Motion for Joinder  
37 C.F.R. § 42.122(b)

## I. INTRODUCTION

Petitioner, Coriant Operations, Inc., Coriant (USA) Inc., Ciena Corporation, Cisco Systems, Inc., and Fujitsu Network Communications, Inc., filed a Petition requesting an *inter partes* review of claims 1–4, 9, 10, 13, 17, 19–23, 27, 29, 44–46, 53, and 61–65 of U.S. Patent No. RE42,678 E (“the ’678 patent”). Paper 6 (“Pet.”). Petitioner also filed a Motion for Joinder, pursuant to 35 U.S.C. § 315(c) and 37 C.F.R. §§ 42.22 and 42.122(b), seeking to join this proceeding with *JDS Uniphase Corporation v. Capella Photonics, Inc.*, Case IPR2015-00739 (“IPR-739”). Paper 7 (“Motion” or “Mot.”). In IPR-739, *inter partes* review of the ’678 patent was instituted on August 25, 2015, on the same grounds asserted against the same claims challenged in this proceeding. *See* IPR-739, Paper 7.

Patent Owner, Capella Photonics, Inc., did not file either a Preliminary Response to the Petition or an Opposition to the Motion for Joinder. Petitioner represents that the petitioner in IPR-739, Lumentum Holdings, Inc., Lumentum, Inc., and Lumentum Operations LLC, (collectively, “Lumentum,” formerly JDS Uniphase Corporation), does not oppose the Motion. Mot. 3.

For the reasons described below, we institute an *inter partes* review of claims 1–4, 9, 10, 13, 17, 19–23, 27, 29, 44–46, 53, and 61–65 of the ’678 patent and grant Petitioner’s Motion for Joinder.

## II. INSTITUTION OF INTER PARTES REVIEW

### A. *The '678 patent (Ex. 1001)*

The '678 patent, titled “Reconfigurable Optical Add-Drop Multiplexers with Servo Control and Dynamic Spectral Power Management Capabilities,” reissued September 6, 2011, from U.S. Patent No. RE 39,397 (“the '397 patent”). Ex. 1001. The '397 patent reissued November 14, 2006, from U.S. Patent No. 6,625,346 (“the '346 patent”). *Id.* The '346 patent issued September 23, 2003, from U.S. Patent Application No. 09/938,426, filed August 23, 2001.

The '678 patent describes a “wavelength-separating-routing (WSR) apparatus that uses a diffraction grating to separate a multi-wavelength optical signal by wavelength into multiple spectral characters, which are then focused onto an array of corresponding channel micromirrors.” *Id.* at Abstract. “The channel micromirrors are individually controllable and continuously pivotable to reflect the spectral channels into selected output ports.” *Id.* According to Petitioner, the small, tilting mirrors are sometimes called Micro ElectroMechanical Systems or “MEMS.” Pet. 9. The WSR described in the '678 patent may be used to construct a dynamically reconfigurable optical add-drop multiplexer (“ROADM”) for wavelength division multiplexing (“WDM”) optical networking applications. Ex. 1001, Abstract.

Figure 1A of the '678 patent is reproduced below.

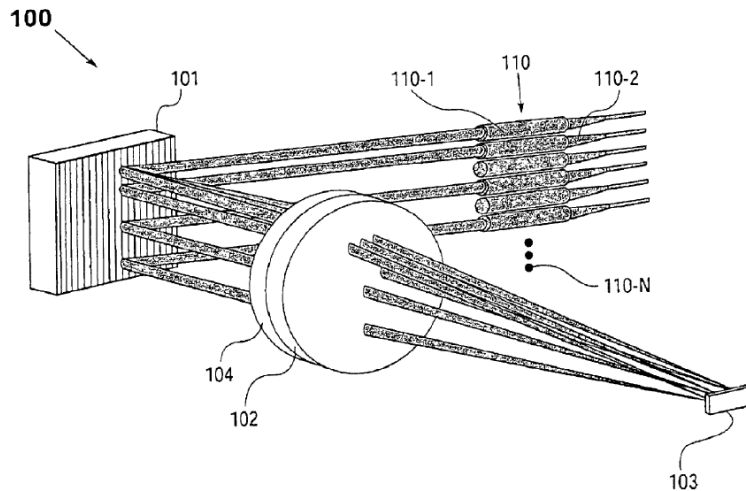

Fig. 1A

Figure 1A depicts WSR apparatus 100, in accordance with the '678 patent. WSR apparatus 100 is comprised of an array of fiber collimators 110 (multiple input/output ports, including input port 110-1 and output ports 110-2 through 110-N), diffraction grating 101 (a wavelength separator), quarter wave plate 104, focusing lens 102 (a beam-focuser), and array of channel micromirrors 103. Ex. 1001, 6:57-63, 7:55-56.

A multi-wavelength optical signal emerges from input port 110-1 and is separated into multiple spectral channels by diffraction grating 101, which are then focused by focusing lens 102 into a spatial array of distinct spectral spots (not shown). *Id.* at 6:64-7:2. Channel micromirrors 103 are positioned such that each channel micromirror receives one of the spectral channels. *Id.* at 7:2-5.

The WSR may also incorporate a servo-control assembly (together termed a “WSR-S apparatus.”) Ex. 1001, 4:65–67. According to the ’678 patent:

The servo-control assembly serves to monitor the power levels of the spectral channels coupled into the output ports and further provide control of the channel micromirrors on an individual basis, so as to maintain a predetermined coupling efficiency of each spectral channel in one of the output ports. As such, the servo-control assembly provides dynamic control of the coupling of the spectral channels into the respective output ports and actively manages the power levels of the spectral channels coupled into the output ports.

*Id.* at 4:47–56.

#### *B. Illustrative Claims*

Claims 1, 21, 44, and 61 of the ’678 patent are independent. Claims 2–4, 9, 10, 13, 17, 19, and 20 ultimately depend from claim 1; claims 22, 23, 27, and 29 ultimately depend from claim 21; claims 45, 46, and 53 ultimately depend from claim 44; and, claims 62–65 ultimately depend from claim 61. Claims 1, 21, and 61 of the ’678 patent are illustrative of the claims at issue:

1. A wavelength-separating-routing apparatus, comprising:
  - a) multiple fiber collimators, providing an input port for a multi-wavelength optical signal and a plurality of output ports;
  - b) a wavelength-separator, for separating said multi-wavelength optical signal from said input port into multiple spectral channels;
  - c) a beam-focuser, for focusing said spectral channels into corresponding spectral spots; and
  - d) a spatial array of channel micromirrors positioned such that each channel micromirror receives one of said spectral channels, said channel micromirrors being *pivotal*

# Explore Litigation Insights

Docket Alarm provides insights to develop a more informed litigation strategy and the peace of mind of knowing you're on top of things.

## Real-Time Litigation Alerts



Keep your litigation team up-to-date with **real-time alerts** and advanced team management tools built for the enterprise, all while greatly reducing PACER spend.

Our comprehensive service means we can handle Federal, State, and Administrative courts across the country.

## Advanced Docket Research



With over 230 million records, Docket Alarm's cloud-native docket research platform finds what other services can't. Coverage includes Federal, State, plus PTAB, TTAB, ITC and NLRB decisions, all in one place.

Identify arguments that have been successful in the past with full text, pinpoint searching. Link to case law cited within any court document via Fastcase.

## Analytics At Your Fingertips



Learn what happened the last time a particular judge, opposing counsel or company faced cases similar to yours.

Advanced out-of-the-box PTAB and TTAB analytics are always at your fingertips.

## API

Docket Alarm offers a powerful API (application programming interface) to developers that want to integrate case filings into their apps.

## LAW FIRMS

Build custom dashboards for your attorneys and clients with live data direct from the court.

Automate many repetitive legal tasks like conflict checks, document management, and marketing.

## FINANCIAL INSTITUTIONS

Litigation and bankruptcy checks for companies and debtors.

## E-DISCOVERY AND LEGAL VENDORS

Sync your system to PACER to automate legal marketing.