

UNITED STATES PATENT AND TRADEMARK OFFICE

BEFORE THE PATENT TRIAL AND APPEAL BOARD

JDS Uniphase Corporation
Petitioner

v.

Capella Photonics, Inc.
Patent Owner

Patent No. RE42,678
Filing Date: June 15, 2010
Reissue Date: September 6, 2011

Title: RECONFIGURABLE OPTICAL ADD-DROP MULTIPLEXERS WITH
SERVO CONTROL AND DYNAMIC SPECTRAL POWER MANAGEMENT
CAPABILITIES

DECLARATION OF SHELDON MCLAUGHLIN

Inter Partes Review No. Unassigned

Table of Contents

	Page
I. INTRODUCTION AND QUALIFICATIONS	5
A. Education and other background information	5
B. Materials Considered	6
II. LEGAL PRINCIPLES USED IN THE ANALYSIS.....	9
A. Person Having Ordinary Skill in the Art	10
B. Prior Art	11
C. Identification of Combinations of Prior Art	12
D. Broadest Reasonable Interpretations	12
III. THE '678 PATENT	14
IV. STATE OF THE ART OF THE RELEVANT TECHNOLOGY AT THE TIME OF THE ALLEGED INVENTION.....	15
A. Reconfigurable Optical Add-Drop Multiplexers.....	15
B. Wavelength Selective Switches	16
C. Microelectromechanical Systems	20
V. MOTIVATION TO COMBINE	22
A. Motivation to Combine Bouevitch and Sparks	23
VI. BOUEVITCH AND SPARKS RENDER OBVIOUS ALL PETITIONED CLAIMS	28
(a) Claim 1 – Grounds 1 and 2.....	28
(i) Claim 1- preamble.....	28
(ii) Claim element 1[a] - multiple fiber collimators providing input and output ports.....	29
(iii) Element 1[b] – wavelength separator	32
(iv) Element 1[c] - beam-focuser.....	32
(v) Element 1[d] – 2-axis channel micromirrors	34
(vi) Ground 2 – Claim 1 would also have been obvious over Sparks and Bouevitch further in view of Lin.....	37
(vii) “Pivotal about two axes”	41
(viii) Power Control using 2-Axis Mirrors:	43

(b)	Claim 2	46
(c)	Claim 3	51
(d)	Claim 4	57
(e)	Claim 9	58
(f)	Claim 10	59
(g)	Claim 13	59
(h)	Claim 17 – Grounds 1, 2, 3, and 4.....	60
(i)	Claim 19	62
(j)	Claim 20	63
(k)	Claim 21	66
	(i) Preamble.....	66
	(ii) Claim element 21[a]-21(c).....	66
	(iii) Element 21[d]—array of controllable micromirrors.....	67
	(iv) Element 21[e]—servo-control.....	67
(l)	Claim 22	68
(m)	Claim 23	68
(n)	Claim 27	68
(o)	Claim 28	69
(p)	Claim 29	69
(q)	Claim 44	69
	(i) Preamble.....	70
	(ii) Claim element 44[a]—fiber collimator ports: input, outputs, pass-through, and drops	71
	(iii) Element 44[d]—control power of spectral channels into output ports including a pass-through port.....	72
(r)	Claim 45	73
(s)	Claim 46	73
(t)	Claim 51	74
(u)	Claim 53	74
(v)	Claim 61	74
	(i) Claim element 61[a]—receive signal from input	75

(ii)	(Element 61[b]—separating the multi-wavelength signal into spectral channels	75
(iii)	Element 61[c]—focus spectral channels onto array of beam-deflecting elements	76
(iv)	Element 61[d]—dynamically and continuously controlling direction and power of spectral channels.....	76
(w)	Claim 62	77
(x)	Claim 63	78
(y)	Claim 64	78
(z)	Claim 65	79
(aa)	Claim 67	79
VII.	CONCLUSION	80

I, Sheldon McLaughlin, declare as follows:

I. INTRODUCTION AND QUALIFICATIONS

1. I have been asked by JDS Uniphase Corporation (“JDSU”) to opine on certain matters regarding U.S. Patent No. RE42,678, hereinafter referred to as the ‘678 Patent. Specifically, this declaration addresses the obviousness of the ‘678 Patent in light of prior art.

A. Education and other background information

2. I hold the position of Senior Principal Optical Development Engineer in the Exploratory Research Group at JDS Uniphase. I received my B.Sc. degree in Engineering Physics from Queen’s University in Kingston, Ontario in 1996, my M.A.Sc. degree in Engineering Science from Simon Fraser University in Burnaby, BC in 1999, and my Postgraduate Certificate in Optical Sciences from the University of Arizona in Tucson, Arizona in 2010. I began my career in optical communications in 1990 as a student at Bell-Northern Research in Ottawa, Ontario. I joined JDS Uniphase in Ottawa in 1999. From 1999 to 2002, I worked on optical design and product development of fiber optic components including an interleaver, a tunable dispersion compensator, and an integrated planar lightwave circuit of a reconfigurable optical add-drop multiplexers. From 2002 to the present, I have been primarily responsible for optical design and development of wavelength selective switches at JDS Uniphase. I designed the optics for the industry’s first commercially available

MEMS WSS, JDSU's "MWS50", and I have taken a lead role in the optical design and development of each successive generation of JDSU's WSS products since then. I hold 8 US patents relating to fiber optic devices, and I have authored or co-authored approximately 12 journal or conference papers, including 2 invited papers on WSS technology. From 2009 to 2011 I served on the technical program subcommittee for the OFC-NFOEC conference.

B. Materials Considered

3. The analysis that I provide in this Declaration is based on my education and experience in the field of photonics, as well as the documents I have considered, including Ex. 1001 (U.S. Patent No. RE42,678, herein "the '678 Patent"), which states on its face that it issued from an application filed on August 23, 2001.

4. Furthermore, I have reviewed relevant portions of various publications from the art at the time of the alleged invention of the '678 patent, to which this Declaration relates. These publications include those listed below:

Exhibit 1001: U.S. Reissued Patent No. RE42,678 to Wilde et al.
("678 patent")

Exhibit 1003: U.S. Patent No. 6,498,872 to Bouevitch et al.
("Bouevitch")

Exhibit 1004: U.S. Patent No. 6,625,340 to Sparks et al. ("Sparks Patent," or
"Sparks")

Exhibit 1005: Excerpts from Born et al., PRINCIPLES OF OPTICS,
(6th Ed., Pergammon Press 1984)

- Exhibit 1006: U.S. Patent No. 6,798,992 to Bishop et al. (“Bishop”)
- Exhibit 1007: U.S. Patent No. 6,507,421 to Bishop et al. (“Bishop ‘421”)
- Exhibit 1009: U.S. Patent No. 6,253,001 to Hoen (“Hoen”)
- Exhibit 1010: U.S. Patent No. 5,661,591 to Lin et al. (“Lin”)
- Exhibit 1011: Doerr et al., An Automatic 40-Wavelength Channelized Equalizer, IEEE Photonics Technology Letters, Vol., 12, No. 9, (Sept. 2000)
- Exhibit 1015: Ford et al., *Wavelength Add-Drop Switching Using Tilting Micromirrors*, Journal of Lightwave Technology, Vol. 17, No. 5 (May 1999) (“Ford, Tilting Micromirrors”)
- Exhibit 1016: U.S. Patent No. 6,069,719 to Mizrahi (“Mizrahi”)
- Exhibit 1017: U.S. Patent No. 6,204,946 to Aksyuk et al. (“Aksyuk”)
- Exhibit 1018: U.S. Patent Application Publication No. US 2002/0105692 to Lauder et al. (“Lauder”)
- Exhibit 1019: Giles et al., Reconfigurable 16-Channel WDM DROP Module Using Silicon MEMS Optical Switches, IEEE Photonics Technology Letters, Vol. 11, No. 1, (Jan. 1999) (“Giles 16-Channel WDM DROP Module”)
- Exhibit 1020: Andrew S. Dewa, and John W. Orcutt, *Development of a silicon 2-axis micro-mirror for optical cross-connect*, Technical Digest of the Solid State Sensor and Actuator Workshop, Hilton Head Island, SC, June 4-8, 2000) at pp. 93–96 (“Dewa”)
- Exhibit 1021: U.S. Patent No. 6,011,884 to Dueck et al. (“Dueck”)
- Exhibit 1022: U.S. Patent No. 6,243,507 to Goldstein et al. (“Goldstein ‘507”)
- Exhibit 1023: U.S. Patent No. 6,567,574 to Ma, et al. (“Ma”)

Exhibit 1026: U.S. Patent No. 5,875,272 to Kewitsch et al. (“Kewitsch”)

Exhibit 1027: U.S. Patent No. 6,285,500 to Ranalli et al. (“Ranalli”)

Exhibit 1031: U.S. Patent No. 5,414,540 to Patel et al. (“Patel ‘540”)

Exhibit 1029: Declaration of Dan Marom as filed in *Inter Partes* Review No. 2014-01276 (“Marom Declaration”)

Exhibit 1032: Borella, et al., *Optical Components for WDM Lightwave Networks*, Proceedings of the IEEE, Vol. 85, NO. 8, August 1997 (“Borella”)

Exhibit 1033: U.S. Patent No. 6,928,244 to Goldstein et al. (“Goldstein ‘244”)

Exhibit 1035: C. Randy Giles and Magaly Spector, *The Wavelength Add/Drop Multiplexer for Lightwave Communication Networks*, Bell Labs Technical Journal, (Jan.-Mar. 1999) (“Giles and Spector”)

Exhibit 1036: U.S. Patent No. 5,872,880 to Maynard (the “Maynard patent”)

Exhibit 1039: Excerpts from Shigeru Kawai, HANDBOOK OF OPTICAL INTERCONNECTS (2005)

Exhibit 1040: U.S. Patent No. 6,625,350 to Kikuchi (“Kikuchi”)

Exhibit 1041: Joseph E. Ford & James A. Walker, *Dynamic Spectral Power Equalization Using Micro-Opto-Mechanics*, IEEE Photonics Technology Newsletter, Vol. 10, No. 10, (Oct. 1998) (“Ford & Walker, Spectral Power Equalization”)

Exhibit 1042: U.S. Patent No. 5,048,912 to Kunikane et al. (“Kunikane patent”)

Exhibit 1043: U.S. Patent No. 5,315,431 to Masuda et al. (“Masuda patent”)

Exhibit 1044: S. Yuan, and N. A. Riza, *General formula for coupling loss characterization of single mode fiber collimators by use of*

gradient index rod lenses, Appl. Opt. Vol. 38, No. 10, at 3214–3222, (1999)

Exhibit 1045: Ming C. Wu, *Micromachining for Optical and Optoelectronic Systems*, Proc. IEEE, Vol. 85, No. 11, at 1833–56 (Nov. 1997) (“Wu, Micromachining”)

Exhibit 1046: Sir Isaac Newton, *Opticks or a treatise of the reflections, refractions, and inflections and colors of light* (1730)

Exhibit 1048: Richard S. Muller & Kam Y. Lau, *Surface-Micromachined Microoptical Elements and Systems*, Proceedings of the IEEE, Col. 86, No. 8 (August 1998)(“Muller and Lau”).

5. I make special note of the Marom Declaration (Ex. 1029). This declaration was submitted and published in connection with Inter Partes Review No. 2014-01276. Inter Partes Review No. 2014-01276 also addresses the same patent, RE42,678, at issue in the present Petition for inter partes review. I have read the Marom Declaration and it informs my present declaration. For example, substantial portions of the Marom Declaration are repeated herein without particular attribution, including, but not limited to, those portions herein that discuss the state of the art at the earliest priority filing of the ‘678 Patent and those portions that discuss Bouevitch, Bishop, Hoen, Dueck, and Lin.

II. LEGAL PRINCIPLES USED IN THE ANALYSIS

6. I am not a patent attorney, nor have I independently researched the law on patent validity. Attorneys for the Petitioner have explained certain legal

principles to me that I have relied upon in forming my opinions set forth in this report.

A. Person Having Ordinary Skill in the Art

7. I understand that my assessment of claims of the '678 patent must be undertaken from the perspective of what would have been known or understood by a person having ordinary skill in the art, reading the '678 patent on its relevant filing date and in light of the specification and file history of the '678 patent. I will refer to such a person as a "PHOSITA."

8. For the relevant priority date for the '678 patent, I have used in my declaration the earliest application date on the face of the patent: Mar. 19, 2001. However, I have not yet analyzed whether the '678 patent is entitled to that date for its priority.

9. Counsel has advised me that to determine the appropriate level of one of ordinary skill in the art, the following four factors may be considered: (a) the types of problems encountered by those working in the field and prior art solutions thereto; (b) the sophistication of the technology in question, and the rapidity with which innovations occur in the field; (c) the educational level of active workers in the field; and (d) the educational level of the inventor.

10. With a career in optical communications spanning approximately 25 years, I am well acquainted with the level of ordinary skill required to

implement the subject matter of the '678 patent. I have direct experience with and am capable of rendering an informed opinion on what the level of ordinary skill in the art was for the relevant field as of March 2001.

11. The relevant technology field for the '678 patent is free-space photonic switching sub-systems, a field related to free-space optics. Based on this, and the four factors above, it is my opinion that PHOSITA would have been an engineer or physicist with at least a Master's degree, or equivalent experience, in optics, physics, electrical engineering, or a related field, including at least three years of additional experience designing, constructing, and/or testing optical systems.

12. My analysis and opinions regarding the '678 patent have been based on the perspective of a person of ordinary skill in the art as of March 2001.

B. Prior Art

13. I understand that the law provides categories of information that constitute prior art that may be used to anticipate or render obvious patent claims. To be prior art to a particular patent claim under the relevant law, I understand that a reference must have been made, known used, published, or patented, or be the subject of a patent application by another, before the priority date of the patent. I also understand that the PHOSITA is presumed to have knowledge of the relevant prior art.

C. Identification of Combinations of Prior Art

14. I understand that the Petitioner is requesting inter partes review of claims 1-4, 9, 10, 13, 17, 19-23, 27, 29, 44-46, 53, and 61-65 of the '678 patent under the grounds set forth in Table 1, below. I will sometimes refer to these combinations as Ground Nos. 1, 2, 3 or 4 in the remainder of my declaration below.

Table 1

Ground	'678 Patent Claims	Basis for Challenge
1	1-4, 9, 10, 13, 17, 19-23, 27, 29, 44- 46, 53, and 61-65	Obvious under § 103(a) by Bouevitch in view of Sparks.
2	1-4, 9, 10, 13, 17, 19-23, 27, 29, 44- 46, 53, and 61-65	Obvious under § 103(a) by Bouevitch in view of Sparks further in view of Lin.
3	17, 29, and 53	Obvious under § 103(a) by Bouevitch in view of Sparks in further view of Dueck.
4	17, 29, and 53	Obvious under § 103(a) by Bouevitch in view of Sparks and Lin in further view of Dueck.

D. Broadest Reasonable Interpretations

15. I understand that, in Inter Partes Review, the claim terms are to be given their broadest reasonable interpretation (BRI) in light of the specification. See 37 C.F.R. § 42.100(b). In performing my analysis and rendering my opinions, I have interpreted claim terms for which the Petitioner has not proposed a BRI construction by giving them the ordinary meaning they would have to a the PHOSITA, reading the '678 Patent with its priority filing date (March 19, 2001) in mind, and in light of its specification and file history.

16. I understand that the Petitioner has made determinations about the broadest reasonable interpretations of several of the claim terms in the '678 patent. I have identified these BRIs in Table 2, below.

Table 2

Term	Broadest Reasonable Interpretation (BRI)
“continuously controllable/[controlling]” (e.g., claims 1–19, 44–67)	“able to effect changes with fine precision”
“pivotal about two axes” (e.g., claims 1 and 44)	“actuatable in two axes”
“spectral monitor” (e.g., claims 3, 22, and 46)	“a device for measuring power in a spectral channel”
“servo-control assembly” and “servo-based” (e.g., claims 2-4, 21-43, and 45-46)	“feedback-based control assembly” and “feedback-based control”
“beam-focuser” (e.g., claims 1-67)	“a device that directs a beam of light to a spot”

“dynamically and continuously controlling” (e.g., claim 61)	"able to effect changes with fine precision during operation"
“in two dimensions” (claim 61)	“in two axes”
“control the power of said received spectral channels” (e.g., claims 1 and 44) and “to control the power of the spectral channels” (e.g., claim 61)	“to change the power of one or more spectral channels”
“optical sensor” (e.g., claim 20)	“a device that measures an optical characteristic”

17. My analysis in this declaration assumes that the terms in Table 2, above, are defined using the associated BRIs. From my reading of the ‘678 patent, I believe that these BRIs are consistent with how one of skill in the art at the time the ‘678 patent was filed would interpret the claim terms.

III. THE ‘678 PATENT

18. As indicated on its face, the ‘678 patent reissued from another U.S. reissue patent Re. 39,397. Re. 39,397 is a reissue of U.S. patent No. 6,625,346. The ‘678 patent claims priority to U.S. provisional application No. 60/277,217, filed on March 19, 2001. The ‘678 patent reissued on September 6, 2011.

19. As its title indicates, the '678 patent relates to reconfigurable optical add-drop multiplexers (ROADMs). (*Id.*, Title (“RECONFIGURABLE OPTICAL ADD-DROP Multiplexers WITH SERVO CONTROL AND DYNAMIC SPECTRAL POWER MANAGEMENT CAPABILITIES”).) More specifically, the '678 patent describes "a wavelength-separating routing (WSR) apparatus and method" (*id.* at Abstract), which separates a multi-wavelength optical signal into separate channels and directs selected channels into selected output ports.

IV. STATE OF THE ART OF THE RELEVANT TECHNOLOGY AT THE TIME OF THE ALLEGED INVENTION

A. Reconfigurable Optical Add-Drop Multiplexers

20. Early optical wavelength-division multiplexed (WDM) networks had fixed wavelength channel optical add drop multiplexers (OADMs), in order for information to be accessible at the network node. A basic OADM sub-system has four fiber ports, with one 'input' fiber port for receiving a WDM signal, a 'drop' fiber port where the WDM channel that is configured to be dropped will emerge, an 'add' fiber port where the replacement WDM channel will be introduced, and an 'output' fiber port for the complete WDM signal (including the replaced channel) which will lead back to the optical network for transmission to the next node. For example, a WDM add/drop multiplexer from before the filing date of the '678 patent is shown symbolically below:

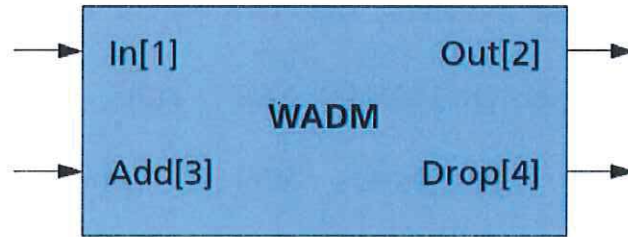

(a) Channel connections from input ports (In[1] and Add[3]) to output ports (Out[2] and Drop[4])

(Giles and Spector, Ex. 1035, *The Wavelength Add/Drop Multiplexer for Lightwave Communication Networks*, Bell Labs Technical Journal, (Jan.-Mar. 1999) at 210). OADMs were sometimes implemented by using fixed filters to extract a single wavelength channel.

21. For greater flexibility in optical network operation, a reconfigurable OADM (a ROADM) was useful to enable network traffic to grow without requiring manual hardware changes. Different implementations of ROADMs were known at the filing date for the '678 Patent. (*See, e.g.*, Ex. 1017, U.S. Patent No. 6,204,946 to Aksyuk et al. ("Aksyuk") (1997) (entitled "Reconfigurable wavelength division multiplex add/drop device using micromirrors"); Ex. 1003, Bouevitch at Abstract (disclosing "a configurable optical add/drop multiplexer (COADM)"); Ex. 1018, U.S. Patent Application Publication No. US 2002/0105692 to Lauder et al., p. 4, Fig. 11.)

B. Wavelength Selective Switches

22. One implementation of ROADMs uses wavelength-selective switches (WSS). WSS is the established category name today for switches that operate on a multi-wavelength optical signal but whose switching function can be tailored per wavelength channel. Circa year 2000 there were a few other names for devices that performed such switching functions such as Wavelength-Routing Switch (or WRS; *see* Ex. 1032, Borella, et al., *Optical Components for WDM Lightwave Networks*, Proceedings of the IEEE, Vol. 85, NO. 8, August 1997 at pp.1292), and Wavelength-Selective Router (“Borella”) (or WSR; *see* Ex. 1026, U.S. Patent No. 5,875,272 to Kewitsch et al. (“Kewitsch”) at Abstract, 4:15-25). Such conventions as WSR and WRS are now referred to as WSS without loss of generality. WSS can be constructed using various methods and technologies, but in the matter of the ‘678 Patent, the WSS is implemented in free-space (as opposed to light guided implementations), using the light radiating out of the transmission optical fiber at the switch input port, and spatially separating this WDM light beam into individual beams using a dispersive optics arrangement (similar to an optical spectrometer). In this arrangement, each beam corresponds to an individual channel distinguished by its unique center wavelength. Each input channel/beam is then individually routed by a beam-steering system and then propagates through the same dispersive optics arrangement, in reverse, to a chosen

output port of the WSS, where all the wavelength channels routed to the port are coupled back to the output optical fiber associated with that port.

23. The WSS can serve as the basis for a ROADM. For example, consider a simple WSS with two optical fibers. The ROADM 'input' fiber port WDM signal is introduced to the first WSS optical fiber. Let all the WSS beam steering elements, except one (or more), tilt the WDM channel beams back towards the first WSS optical fiber, and the one (or more) beam steering element(s) tilts the WDM channel(s) to the second WSS optical fiber. The first set of WDM channels exiting the first WSS optical fiber is then attached to the ROADM 'output' fiber port. The one (or more) WDM channel(s) that was tilted to the second WSS optical fiber is attached to the ROADM 'drop' fiber port. A replacement WDM signal introduced at the ROADM 'add' fiber port is then attached to the second WSS optical fiber and is guided by the WSS configuration (via the one or more beam steering element) to the first WSS optical fiber, where it will emerge on the ROADM 'output' fiber port. In this implementation the two WSS optical fibers carry optical signals bi-directionally to/from the WSS (serving as input/output), to be separated outside of the WSS with an optical circulator for each optical fiber. At ROADM nodes the same WDM channels are often added and dropped at the same time - that is, the added and the dropped channels use the same wavelength, but they contain different information. The dropped channel

information is destined for users at the network node, and the same or others users at the network node upload new information to the network onto the added channel

24. It is advantageous to have the add channel information use the same wavelength as the drop channel (though it is not necessary) for two main reasons: it is known that the dropped wavelength slot is available to accept new information, so no network routing path calculation is invoked and no blocking or contention can occur, and the WSS configuration is already configured by the beam steering element to route the ‘add’ wavelength channel to the ‘output’ port, in the implementation described above.

25. These routing techniques were known prior to the ‘678 priority date. (Bouevitch, Ex. 1003 at 5:15-38; Mizrahi, Ex. 1016 at 1:55-2:45; Aksyuk, Ex. 1017 at 1:56-67.)

26. In addition to routing channels, ROADMs may also be used to control the power of the individual channels at the output fiber port. Power control is used to reduce the power imbalance between wavelength channels, often originating from uneven gain in optical amplifiers. Devices performing such dynamic spectral power control were known before the ‘678 Patent (Ex. 1015, Ford et al., *Wavelength Add-Drop Switching Using Tilting Micromirrors*, Journal of Lightwave Technology, Vol. 17, No. 5 (May 1999) at p. 905). Power control

can be incorporated in the ROADM function by utilizing WSS that can control not only the switching state but also the level of power attenuation to the switched port. In MEMS-based WSS this switching is typically done by steering individual beams slightly away from the output port such that the misalignment reduces the amount of the channel's power that enters the port. This power control technique using WSSs in ROADMs was known prior to the '678 Patent's priority date. (*See e.g.*, Sparks, Ex. 1004 at 4:48-65.) ROADMs use wavelength selective routers (WSRs) to perform switching (*See, e.g.*, Kewitsch, Ex. 1026 at 10:64-11:29.) WSRs are also referred to as wavelength selective switches (WSSs). (*See, e.g.*, Ranalli, Ex. 1027, U.S. Patent No. 6,285,500 to Ranalli at al. ("Ranalli") at Fig. 1.) As of the '678 Patent's priority date, WSRs/WSSs were known. (*See, e.g.*, Kewitsch, Ex. 1026 at Abstract, 4:15-25; Ranalli, Ex. 1027 at Fig. 1; Borella, Ex. 1032 at 1292.)

C. Microelectromechanical Systems

27. The embodiment of WSSs relevant to this petition steers light beams using small tilting mirrors, the tilt of the mirrors actuated by MEMS, which stand for Micro ElectroMechanical Systems. WSSs can tilt the individual mirrors using several different operating methods, including analog voltage control. (*See, e.g.*, Ex. 1010, U.S. Patent No. 5,661,591 to Lin at al. ("Lin") at Fig. 3B, 2:3-9.) MEMS is a broad area of technology and can have many operating modes.

Voltage controlled mirror actuation by electrostatic forces are the easiest to design and realize; there are also magnetic, thermal, and piezo methods as well. Electrostatic MEMS can be operated using analog voltage for continuous control, binary voltage for two-state control, and there is also a variant using rapid switching of a binary voltage to mimic analog voltage since the mirror is a slowly moving device and acts as a low pass filter (a technique called pulse width modulation).

28. Prior-art MEMS mirrors could be tilted in one or two axes. (Sparks, Ex. 1004 at 4:18-26 and 42-47, Fig. 1; U.S. Patent No. 6,567,574 to Ma, et al. (“Ma”), Ex. 1023 at Fig. 5; Andrew S. Dewa, and John W. Orcutt, *Development of a silicon 2-axis micro-mirror for optical cross- connect*, Technical Digest of the Solid State Sensor and Actuator Workshop, Hilton Head Island, SC (June 4-8, 2000) (“Dewa”) Ex. 1020 at p. 93.) Such 2-axis actuating mirrors were known for many years prior to the filing of the ‘678 Patent. For example, U.S. Patent No. 5,872,880 to Maynard (“Maynard”) Ex. 1036, filed on August 12, 1996, is entitled a “Hybrid-optical multi-axis beam steering apparatus” and notes that “An aspect of the invention provides a micromachined mirror which is capable of steering a beam of light with multiple degrees of freedom.” (*Id.* at 3:9-11.) Maynard also notes that “the micromirror is precisely steered by

the application of a controlled electrostatic effect, in either a current or a voltage mode.” (*Id.* at 3:15-18.)

V. MOTIVATION TO COMBINE

29. I am informed that in order to properly combine the Bouevitch, Sparks and other references for purposes of obviousness, it is important to provide an explanation as to why the PHOSITA would have been motivated to combine those references. It would have been obvious to PHOSITA to combine the disclosures of Bouevitch and Sparks, and other references, as explained in more detail below. In particular, it would have been obvious to replace the (arguably) 1-axis actuating mirrors in the Bouevitch optical switch with the 2-axis actuating mirrors disclosed in Sparks, especially since Bouevitch notes that the 1-axis orientation can be in an arbitrary orientation with respect to dispersion axis, i.e. either horizontal or vertical (Ex. 1003 at 15:30-34). Moreover, it would have been obvious to the PHOSITA to implement the power control function, disclosed in Sparks, in the ROADM of Bouevitch, at least because of the advantages provided by such power control in minimizing signal noise in multiplexed optical signals as disclosed by Sparks. (Sparks, Ex. 1004 at 1:11-25.) These and other reasons are further discussed below. As I discuss later in this declaration, it would also have been obvious to combine the Lin and Dueck references with Bouevitch and/or Sparks.

A. Motivation to Combine Bouevitch and Sparks

30. First, the PHOSITA would know that techniques used in one reference would be directly applicable to the other. For example, both Bouevitch and Sparks are directed to similar devices, specifically optical signal switches for use in telecommunications systems (Bouevitch, Ex. 1003 at 1:10-15 and 31-34; Sparks, Ex. 1004 at 4:3-14, 33-38, and 59-60). It is noted that Lin and Dueck are similarly directed to optical signal switches (Lin, Ex. 1010 at Title; Dueck, Ex. 1021 at 3:3-5). Knowing that the references were directed to similar components, fields, and uses, the PHOSITA would have understood that the teachings of any one reference would be readily applicable to the others.

31. Second, the PHOSITA would further know that the 2-axis actuating mirrors of Sparks could be substituted for the 1-axis actuating mirrors in Bouevitch. The actuating mirrors of Sparks and Bouevitch are MEMS-based. (Bouevitch, Ex. 1003 at 14:5-10 and 52-65; Sparks, Ex. 1004 at 4:42-47). The PHOSITA would understand that the principles of operation of the MEMS-based actuating mirrors are essentially the same except that the mirrors of Sparks are actuatable in one more axis than those of Bouevitch. The effect of tilting a MEMS mirror in 2 axes for the steering of a light beam is entirely predictable in view of the effect of a MEMS mirror tilting in 1 axis for the steering of a light beam. Because the implementation of both 1-axis and 2-axis actuating mirrors were

known at the time of the '678 Patent, the PHOSITA would also expect that using the 2-axis MEMS-based mirrors of Sparks for directing a beam of light in place of the 1-axis MEMS-based mirrors of Bouevitch would yield a predictable result of the same functionality (e.g., movement of a reflective surface in a first axis) yet with more control (e.g., the reflective surface moving in a second axis in similar manner as the movement in the first axis). There are virtually no technical obstacles to the substitution of a known 2-axis articulating mirror for a known 1-axis articulating mirror and the advantages of such a substitution are easily recognizable.

32. Third, it would be obvious for the PHOSITA to try Sparks' 2-axis actuating mirrors in Bouevitch because 2-axis actuating mirrors were among a small number of well-known and predictable solutions for beam-deflecting, and the PHOSITA would have expected to have success building devices using either type of mirror. 1-axis and 2-axis actuating mirrors were recognized in the prior art as interchangeable options, the selection of which merely depended on the preference of the engineer. (See Bishop '421, Ex. 1007 at 4:17-19 (claiming in the alternative a cross connect with "an array of tiltable mirrors comprising a plurality of mirrors, each mirror being tiltable about *at least one* tilting axis"); emphasis added.) Because Bouevitch already disclosed the use of 1-axis MEMS-based mirrors, the PHOSITA would have a high expectation of success in trying Sparks'

2-axis MEMS-based mirrors for any beam reflecting application in Bouevitch, including switching and power control.

33. Fourth, the PHOSITA would have been motivated to use the 2-axis actuating mirrors of Sparks in place of the 1-axis actuating mirrors of Bouevitch to take advantages of the benefits highlighted by Sparks. For example, the 2-axis actuating mirrors are described by Sparks to “precisely direct[] the beam” (Ex. 1004 at 4:21) and to “carefully align the beams so as to ensure that the maximum possible input optical signal is received at the output of the switch” (*Id.* at 4:45-47.) The PHOSITA would have readily recognized the benefits of precise beam control in 2-axes as in Sparks as compared to 1-axis beam control as in Bouevitch and would have been motivated to carry out a straightforward replacement of the 1-axis actuating mirrors of Bouevitch with the 2-axis actuating mirrors of Sparks.

34. Fifth, consistent with Sparks’ statement that 2-axis actuating mirrors allows “the maximum possible input optical signal is received at the output of the switch (*Id.* at 4:46-47), the PHOSITA would have realized that Sparks’ 2-axis actuating mirrors can help overcome manufacturing deviations. When assembling any optical system such as a WSS, tolerances in component production and assembly cause deviations from the ideal working conditions. Having mirrors with 2-axis angular optimization can reduce or even eliminate the

effect of these alignment deviations on the efficiency of light coupling to an optical fiber. The 2-axis actuating mirrors can account for unintentional misalignment due to manufacturing tolerances in both axes whereas a 1-axis mirror would only be able to adjust for unintentional misalignment in 1-axis.

35. Sixth, the PHOSITA would have been motivated to combine the teachings of Sparks with those of Bouevitch because Sparks addresses a problem, and is directed to a goal, identified in Bouevitch. Specifically, Bouevitch states “In optical wavelength division multiplexed (WDM) communication systems, an optical waveguide simultaneously carries many different communication channels in light of different wavelengths. In WDM systems it is desirable to ensure that all channels have nearly equivalent power.” (Bouevitch, Ex. 1003 at 1:18-22.). In seeking to “ensure that all channels have nearly equivalent power” (*Id.*), the PHOSITA would recognize Sparks as relevant and applicable. In this regard, Sparks states:

The control of optical power levels in optical communications systems is critical in obtaining optimum performance. The power level needs to be sufficient to establish a signal to noise ratio which will provide an acceptable bit error rate but without the power level exceeding a level at which limiting factors (e.g. the onset of non-linear effects) result in degradation of the signal or other co-propagating signals.

In wavelength division multiplexed (WDM) transmission, it is desirable to control the power of the individual optical channels or wavelengths. Channels could be controlled to provide constant system signal to noise ratio. One of the simplest methods of

control is to maintain each of the power levels of the individual wavelength components (channels) at substantially the same level. Ex. 1004 at 1:9-25.

To maintain the desired power level of channels, Sparks teaches:

controlled misalignment of the optical beam path so as to achieve a predetermined optical output power . . . If the optical system is being used as part of a WDM system, it is typical for the signal to be demultiplexed into the separate optical channels prior to input to the switch. If desired, each of the channels passing through the switch may be attenuated to whatever degree necessary to achieve the desired effect, e.g. equalisation of optical power across all channels. (Ex. 1004 at 2:24-36.)

36. As such, the PHOSITA would have been motivated to utilize the 2-axis actuating mirror and power control feature of Sparks which were directly on point with addressing the need, identified by Bouevitch, for all channels having nearly equivalent power.

37. The power control teachings of Sparks “may equally be applied to any optical switch utilizing any one or more of reflection, refraction and/or diffraction” (*Id.* at 5:58-62.) Being that light beams in Bouevitch reflect off of reflectors 51, 52 to be aligned with parts 1, 2, or 3 associated with circulator 80a (and the port 85), it would be a straightforward application of the teachings of Sparks to misalign a beam with one of the parts 1, 2, or 3 associated with circulator 80a and/or the port 85 to have the predictable effect of selectively reducing the power of the spectral channel carried by the beam. (Bouevitch, Ex. 1003 at 14:39-60; see Fig. 11.) Intentional misalignment between the beam and

port 85 could have been precisely controlled with the 2-axis mirror of Sparks which was readily combinable with Bouevitch as discussed above.

38. For at least the reasons discussed above, the PHOSITA would have sought Sparks in addressing the problems and goals identified in Bouevitch in making a ROADM, and would have found the relevant teachings of Sparks combinable with Bouevitch to achieve a predictable outcome. These known and readily combination teachings render the claims of the '678 Patent obvious, as further discussed herein.

VI. BOUEVITCH AND SPARKS RENDER OBVIOUS ALL PETITIONED CLAIMS

(a) Claim 1 – Grounds 1 and 2

39. The section addresses claim 1 first under Ground No. 1 of Bouevitch+Sparks, and then under Ground No. 2 of Bouevitch+Sparks+Lin.

(i) Claim 1- preamble

40. The preamble of claim 1 recites “[a] wavelength-separating-routing apparatus, comprising...” Bouevitch discloses a “Configurable Optical Add/Drop Multiplexer (COADM)” that spatially **separates** light beams **according to** wavelength and **routes** each separated sub-beam along a designated pathway (e.g., to either a pass-through or a drop port). Ex. 1003, 2:29-33, Abstract; *see also id.*, 8:8–41, 5:15–20, 14:14-21, Figs. 1, 11; 3:9-63.) Thus, the COADM of Bouevitch constitutes a “wavelength-separating-routing apparatus.” Such devices

constitute important elements in optical networks employing WDM and optical routing at nodes. An ingress fiber carrying WDM data channels has its WDM channels routed to different egress fibers for sending select WDM channel subsets to their identified destination. Such capability is enabled with a multi-output ROADM node.

(ii) Claim element 1[a] - multiple fiber collimators providing input and output ports

41. The first limitation of claim 1 recites “multiple fiber collimators, providing an input port for a multi-wavelength optical signal and a plurality of output ports.” The remainder of this section addresses element 1[a] in three sub-parts.

42. (1) “Multiple fiber collimators”: Fig. 11-Annotation 1, below, shows two microlens fiber collimators (12a and 12b) annotated as “M” (*see also id.*, 14:19–21)::

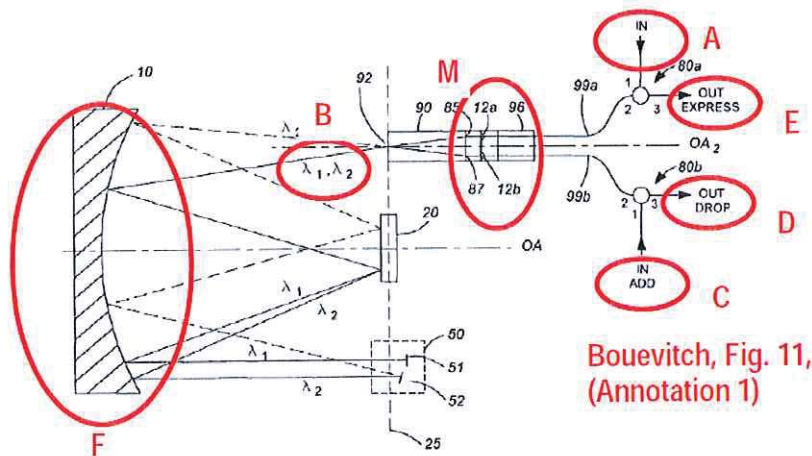

43. Microlenses are one well-known type of fiber collimator. (Shigeru Kawai, Handbook of Optical Interconnects, Ex. 1039 at 327; Kikuchi, Ex. 1040 at Abstract.) Bouevitch also refers to fiber collimators such as graded index or GRIN lenses. (12:18-40.) Fiber collimators are required to control the spread of light coming from a cut optical fiber. Fibers that are cut and from which light is radiating outwards will rapidly diffract or spread. A lens can be placed to align or ‘collimate’ this spreading beam into a slowly diffracting or spreading beam. Controlling the light beam spread with a lens was well known. (See, e.g., Ex. 1042, US Patent No. 5,048,912 (making use of ball lens to serve as fiber collimator in an optical fiber switch); Ex. 1043, US Patent No. 5,315,431 (making use of ball lens to serve as fiber collimator in optical isolator); Ex. 1044, S. Yuan & N. A. Riza, General formula for coupling loss characterization of single mode fiber collimators by use of gradient index rod lenses, Appl. Opt. Vol. 38, No. 10, at 3214-3222, (1999) (fiber collimators with GRIN lenses); Ex. 1045, Ming C. Wu, Micromachining for Optical and Optoelectronic Systems, Proc. IEEE, Vol. 85, No. 11, at 1833-56 (Nov. 1997)(Fresnel lens made with micromachining); Kikuchi, Ex. 1040 at [0005] (teaching how to make array forms of fiber collimators).)

44. (2) “Providing an input port for a multi-wavelength optical signal”: Bouevitch shows how its microlens collimators provide an input port

(“A” in Fig. 11-Annotation 1, above) in conjunction with fiber waveguide 99a and circulator 80a. (Ex. 1003, Fig. 11.) That input port receives a multi-wavelength optical signal that is “launched into” input port “IN” (annotated as “A” in Fig. 11-Annotation 1). (*Id.* at 14:39-42.) This signal is a multi-wavelength signal with a first spectral channel λ_1 and a second channel λ_2 , as shown at annotation “B” of Fig. 11-Annotation 1, above (*Id.*, Fig. 11, 14:39-42). The fiber and collimator jointly constitute a fiber port. That port can be assigned to an input fiber port where a WDM signal is introduced to the WSS, or an output fiber port to where selected channels of input WDM signal are routed by the WSS. The collimators—part of the fiber port—help conform the beam spread from the fiber to that which is required internally within the WSS. The collimator (which as discussed in the previous paragraph can be made in various technologies) is a lens of chosen focal length that controls the beam size on the micromirrors and helps set the channel characteristics in the end.

45. (3) “A plurality of output ports”: Bouevitch shows how its microlens collimators also provide two output ports at “E” and “D” in Figure 11-Annotation 1, above. Microlens 12a provides an “Out Express” port in conjunction with fiber waveguide 99a and circulator 80a, and microlens 12b provides an “Out Drop” port in conjunction with waveguide 99b and circulator 80b. (Bouevitch, Ex. 1003, Fig. 11; 14:14-21.)

(iii) Element 1[b] – wavelength separator

46. Limitation 1[b] recites: “a wavelength-separator, for separating said multi-wave-length optical signal from said input port into multiple spectral channels.” Diffraction grating 20 in Bouevitch Fig. 11 is such a separator. Figure 11 shows that grating 20 spatially separates (disperses) combined channels $\lambda_1\lambda_2$ (“A” at Fig. 11-Annotation 2, below) from the input port 80a(1) into separated channels (“B”):

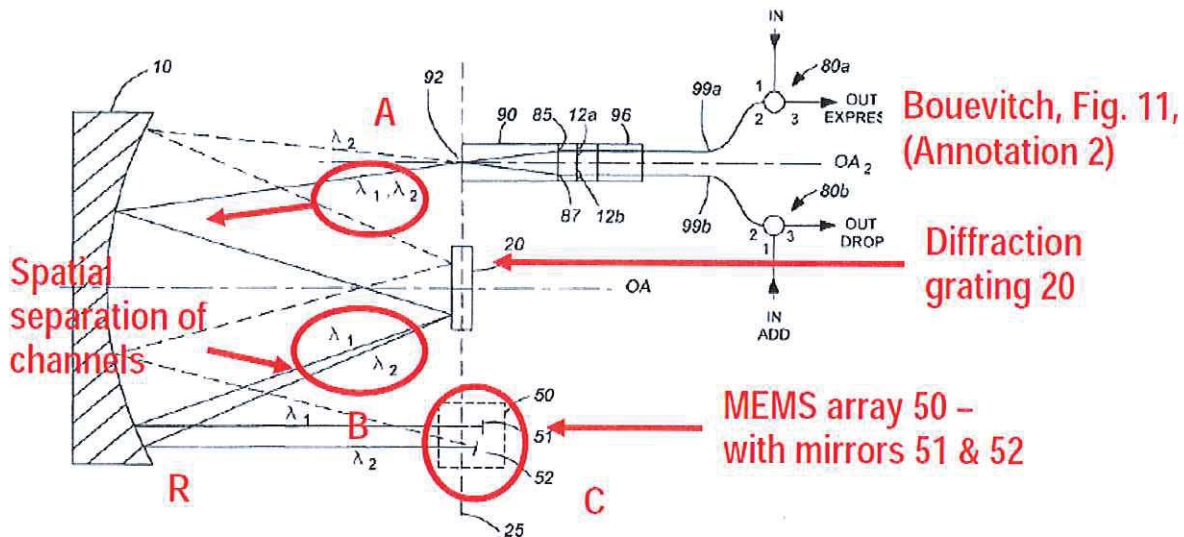

47. Bouevitch states, “[t]he emerging *beam of light $\lambda_1\lambda_2$* , is transmitted to an upper portion of the spherical reflector 10, is reflected, and *is incident on the diffraction grating 20, where it is spatially dispersed into two sub-beams of light carrying wavelengths λ_1 and λ_2 , respectively.*” (Ex. 1003, 14:48-53 (emphasis added); 8:10–22.)

(iv) Element 1[c] - beam-focuser

48. The next element, 1[c], requires “a beam-focuser, for focusing said spectral channels into corresponding spectral spots.” As discussed in § II.D, above, the BRI for “beam focuser” is “a device that directs a beam of light to a spot.”

49. Bouevitch discloses this beam-focuser element at spherical reflector 10 in Figure 11. Referring to Figure 11-Annotation 2 above, spherical reflector 10 focuses the separated spectral channels of light λ_1 and λ_2 from the points on the spherical reflector annotated as “R” onto points on the corresponding mirrors 51 & 52 in MEMS array 50. (Ex. 1003, Figs. 11, 6a, 15:7-11, 14:14-20, 48-55; see also *id.*, Fig. 1, 8:46–49; see also Sparks, Ex. 1004 at 4:16-22 (“a focussing lens 12”) Fig. 1.) A spherical reflector that is concave (as taught in Bouevitch) has optical power, just as lenses do, and will focus an incident collimated beam.

50. Bouevitch’s description of other examples of spherical reflector 10 (examples that Bouevitch describes as “compatible with” the embodiment of Figure 11) confirms that the spherical reflector focuses channels into spectral spots on the mirrors. (*E.g.*, Bouevitch, Ex. 1003, 11:62-63 (“grating 820 is located at the focus of” reflector 810); 10:41-47 “[t]he plurality of *sub-beams of light* are transmitted to the spherical reflector **610** where they are collimated and *transmitted to the modifying means 150* where they are *incident thereon as*

spatially separated spots corresponding to individual spectral channels.” (emphasis added); 13:65-14:1 (noting Figure 9’s compatibility with “modifying means based on MEMS technology”).)

(v) Element 1[d] – 2-axis channel micromirrors

51. This final element of claim 1 has three subparts. Bouevitch teaches the first two, and Sparks teaches the third. Each subpart is discussed in turn, below.

52. (1) Micromirrors: The first part of element 1[d] recites: “a spatial array of channel micromirrors positioned such that each channel micromirror receives a corresponding one of said spectral channels.”

53. Bouevitch discloses this element as MEMS array 50 with reflectors 51 and 52 shown as “C” in Fig. 11-Annotation 2, above. (Ex. 1003, Fig. 11.) The PHOSITA would understand these reflectors to be **micromirrors**, which will reflect incident light according to known reflection rules, i.e., incidence angle is equal to reflected angles (angles measured with respect to reflective surface normal). MEMS are often described in the prior art as arrays of “micromirrors.” (See, e.g., Ford, Ex 1015, Tilting Micromirrors at 904; Goldstein ‘244, Ex. 1033 at 2:23-25 (“the optical switch matrix can be a device, such as a micro electrical mechanical system (MEMs), having an array of micromirrors”).) Bouevitch teaches positioning its micromirrors such that each receives a **corresponding**

spectral channel dispersed by the diffraction grating. (Ex. 1003, 14:53–65, 7:33–38, 10:43-51.)

54. (2) Pivotal About Two Axes, Individually / Continuously Controllable: The second part of limitation 1[d] recites wherein each of the channel micromirrors in the array is “pivotal about two axes” and “individually and continuously controllable to reflect corresponding received spectral channels into any selected ones of said output ports.” The BRI of “continuously controllable” is “able to effect changes with fine precision” (e.g., this controllability could be obtained through the use of analog or digital controls with sufficiently fine output values).

55. First, Bouevitch discloses **individual** control of each mirror in MEMS array 50 in order to direct the corresponding spectral channel into any selected output port. “[E]ach sub-beam of light...is transmitted to separate reflectors 51 and 52 of the MEMS array 50.” (Ex. 1003 at 14:52-63; Fig. 11-Annotation 2.) Each reflector is individually controlled in to deflect the respective beam to either of the output ports at 80a or at 80b. (*Id.*, 14:52-63, 10:47-51, Fig. 11-Annotation 1, elements “D” & “E”)

56. Second, Bouevitch indicates that its reflectors are “continuously controllable” because (as discussed below) the amount of power in the spectral signal that is attenuated is a function of the angle of the deflector in that one axis.

(*Id.*, 7:35-37 (“The degree of attenuation is based on the degree of deflection provided by the reflector (i.e., the angle of reflection”).) Bouevitch also describes the attenuation resulting from the deflector as “variable.” (*Id.*, 12:59-60.), in line with the Bouevitch’s attempts to balance the powers of each of the wavelength channels. Hence the mirror’s tilt is detuned in angle from the peak (or optimal) fiber coupling to induce controlled amounts of loss. This level of control, required to balance the optical power differentials among the wavelength channels is achieved by controlling the mirrors to be able to effect changes with fine precision to align with the ports (and control power through intentional misalignment as further discussed herein) which is within the BRI for “continuously controllable”. Furthermore, the PHOSITA would understand that the level of control, required to balance the optical power differentials among the wavelength channels, is achieved via analog voltage control.

57. Sparks, likewise, teaches what the PHOSITA would understand as mirrors that are controllable to effect changes with fine precision. Sparks states that the mirrors are actuatable “to achieve **any** desired optical beam power output less than the maximum” (Ex. 1004, 4:54-55, emphasis added) and that “each of the channels passing through the switch may be attenuated to **whatever degree necessary** to achieve the desired effect” (*Id.* at 2:33-36, emphasis added). As such, the PHOSITA would understand that the mirrors of Sparks are able to effect

changes with fine precision and are thus within the BRI of “continuously controllable”. Furthermore, the PHOSITA would understand that such precision of mirror control is consistent with the level of fine control provided by analog actuators.

58. This principle of attenuation via control over the MEMS mirror tilt has been established long before the purported priority date of the ‘678 patent. First, the relationships between the light beam parameters (including beam size, location and angle of incidence) arriving to the output fiber and the amount of attenuation have been long established. One can achieve any level of attenuation for a given beam parameter deviation from ideal conditions. For example, for a beam offset from the optical axis of the fiber, the relationship between the power coupled and the offset is a Gaussian function. That is, the reduction in power coupling follows a Gaussian relationship, and the power coupling is reduced monotonically as a function of beam offset. This Gaussian behavior further implies that beam offset from ideal conditions can be to any direction. For example, beam tilt deviation from ideal can be either greater than or less than ideal angle. This attenuation principle has been demonstrated with MEMS tilting mirrors before, as shown at least by Sparks.

- (vi) Ground 2 – Claim 1 would also have been obvious over Sparks and Bouevitch further in view of Lin

59. Another prior art reference that discloses analog control of mirrors is Lin, Ex. 1010. Lin was assigned to Texas Instruments (“TI”). Lin describes one TI MEMS device, and confirms that continuous and analog control of MEMS mirrors was known prior to the ‘678 patent’s priority date. For example, Figure 3B of Lin shows a graph comparing the deflection angle of MEMS mirrors to a voltage applied to affect that deflection. Figure 3B shows the relationship as a continuous, roughly linear relationship within the expected operating range of the device (*Id.* at Fig. 3B):

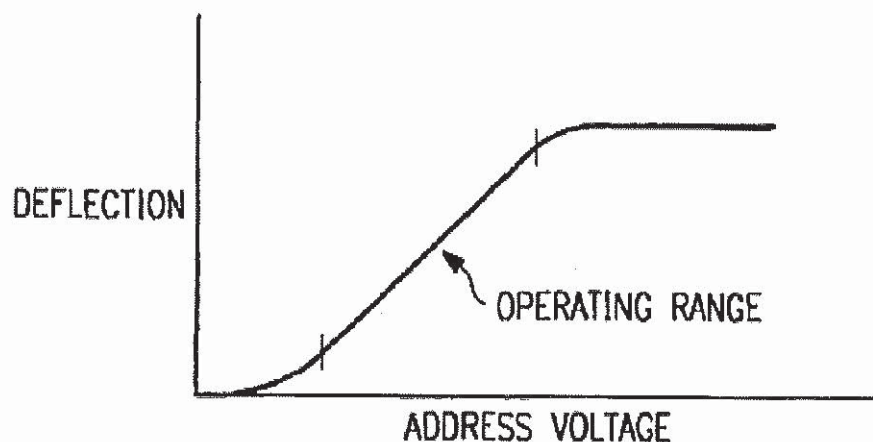

FIG. 3B

(See also Ex. 1034, Steffen Kurth et al., Silicon mirrors and Micromirror Arrays for Spatial Laser Beam Modulation, Sensors and Actuators, A 66, July 1998 (“Kurth”).) Lin also discloses the details of the servo actuation mechanism Lin uses to affect the mirror deflection. (Ex. 1010, 2:66-3:38.)

60. To the extent Bouevitch does not fully disclose continuous (analog) mirror control, it also would have been obvious to substitute one control

method for the other, including substituting either Sparks' or Lin's fine (e.g. analog) control into the COADM of Bouevitch. The PHOSITA would do so for at least for the reasons that (1) continuously controlled mirrors were known to be interchangeable with discrete-step mirrors; (2) continuously controlled mirrors allow arbitrary positioning of mirrors and can be used to achieve optimal coupling value or deviations from angle to lead to controllable attenuation; and (3) Lin specifically teaches that its analog, continuous MEMS mirrors would be useful in optical switching applications like Bouevitch's and Sparks' optical switches. (Lin, Ex. 1010 at 2:6-9.) Such substitution would provide predictable results of fine controllability.

61. With respect to reason (1)—the interchangeability of continuously-controlled mirrors with discrete-step mirrors—this interchangeability is shown in the prior art by references that could use either discrete or analog control to achieve a large number of potential mirror angles. For example, in Muller and Lau 1998 (Ex. 1048), the article's mirrors used an actuation scheme based on small steps induced by vibration. This has the advantage of being 'latched' into position such that tilt angle is preserved when electrical power fails. Similarly, MEMS mirrors based on analog voltage control can also be tilted to any desired angle in their operation range, but voltage has to be permanently placed to maintain mirror angle and the resulting optical power

coupling value (whether implementing best coupling, i.e. 'ideal,' or detuned for power control).

62. With respect to reason (2)—power balancing—continuously controllable mirrors were obvious to use because such mirrors were known to be useful to address the constantly-changing power-balancing requirements in ROADMs. The power balancing requirement in optical networking is varying in time and is mostly dependent on the network wavelength channel routing assignment at any particular time, due to the optical amplifiers in the networking providing different gain depending on the number and spectral placement of wavelength channels. Hence the power balancing function required of the dynamic gain equalization filter (or the ROADM providing the channel attenuation feature) is constantly changing (hence the term 'dynamic'). This requirement can be met with MEMS mirrors whose tilt angles are continuously changing in response to power variations and this can be easily achieved with fine (e.g., analog) control over the MEMS mirror tilt together with feedback control.)

63. In addition, analog (continuous) control of the mirrors would be obvious to try within the applications that Bouevitch discloses. The MEMS mirror alternatives available for system design can be broadly classified as 'analog' and 'binary' MEMS tilting mirrors, with binary mirrors having one of two metastable angular positions and analog mirrors have no metastable positions and have a

continuous angular range which depends on the applied voltage conditions. For example, Lin discusses analog control as an alternative to binary (discrete) control of mirrors to increase the precision of the mirror placement. (Ex. 1010, 2:7-9; 3:41-57; *see also* Kurth, Ex. 1034, 79-80.) In addition, MEMS mirrors can be either latching or non-latching, with latching mirrors maintaining their position even when electrical power is turned off. In simple two state switching scenarios, a binary latching MEMS mirror design has many advantages. However, Bouevitch is trying to power balance wavelength channels in an optical network, which requires continuous power coupling control to offset the dynamics of the network. PHOSITA would know that this power balancing is best achieved with analog non-latching MEMS mirrors.

(vii) “Pivotal about two axes”

64. Returning now to both Grounds 1 and 2, the only portion of the second part of element 1[d] arguably not taught by Bouevitch is a micromirror “pivotal about two axes.” But as discussed in §§ IV.C and V, above, Sparks discloses a 2-axis a beam deflecting element. In particular, Sparks discloses a 2-axis beam deflecting element. In particular, Sparks describes “movable micromirrors (16,26), which are fabricated using MEMS technology and are capable of two axis movement, to carefully align the beams so as to ensure that the maximum possible input optical signal is received at the output of the switch.”

(Ex. 1004 at 4:43-47.) Fig. 1 of Sparks clearly illustrates each of the micromirrors 16, 26 exhibiting pivoting action (in phantom) to redirect a beam 30.

65. As discussed in § V.A, above, it would be obvious (and PHOSITA would be motivated) to exchange the 1-axis mirrors in Bouevitch with the 2-axis mirrors of Sparks because the two types of mirrors were known to be interchangeable. The exchange would achieve the easily recognizable benefit of greater beam control (e.g., 1 vs. 2 axis articulation and beam deflection). As discussed further below, 2-axis actuating mirrors also have known benefits for power control.

66. Replacing Bouevitch's 1-axis mirrors with Sparks' 2-axis mirrors had the known benefit of minimizing the resulting device's size, which is desirable in optical devices. (Ex. 1003, 2:9-21.) PHOSITA knew that 2-axis mirrors allow for beam-steering between more compactly-spaced input/output ports arranged as a 2-D array. (Hoen, Ex. 1009, 1:65-2:13.) The patentee itself acknowledged the need for two-axis mirrors in the '678 patent, saying that when the input and output ports are arranged in a 2-D array, "the channel micromirrors must be pivotable biaxially." (Ex. 1001 at 4:26-29.)

67. An additional benefit for 2-axis mirrors over 1-axis mirrors is the reduced tolerances on assembly of the WSS. The additional degree of MEMS mirror tilt control can be used to find the ideal angle in two dimensional angular

space and optimally couple at peak efficiency to the output fiber. Power control (or attenuation) can be obtained by detuning from optimal coupling angle to any direction (in two dimensional angular space).

68. Bouevitch describes how the goal of controlling the MEMS mirrors is to effect the add/drop process, which includes reflecting the spectral channels to selected add/drop ports. (*See, e.g.*, Ex. 1003 at 14:66-15:18.) Similarly, Sparks discusses “having two arrays of such modules, optical signals coming in from a first array may be directed into any of the output fibres of the second array.” (Ex. 1004 at 4:33-35.) As such, both Bouevitch and Sparks disclose switches having MEMS based micromirrors to redirect a spectral channel to a particular port, the difference between them being a difference in the number of axis of micromirror pivoting (e.g., 1 vs. 2), such that the substitution of Sparks’ 2-axis micromirror for Bouevitch’s 1-axis pivoting micromirror would have been a straightforward substitution with predictable results that would have been obvious to try.

(viii) Power Control using 2-Axis Mirrors:

69. The third part of element 1[d] recites wherein each of the beam-deflecting elements is controllable “to control the power of the spectral channel reflected to said selected port.” Bouevitch discusses power control by tilting one-axis mirrors to effect a slight misalignment between the beam and the output port.

Bouevitch shows how each MEMS mirror controls the power of a “respective” channel, where "the degree of [power] attenuation is based on the degree of deflection provided by the reflector (i.e., the angle of reflection)." (Ex. 1003, 7:34-37; *see also Id.*, 1:21-24, 50-53; 5:16-46; 2:22-25; Abstract.)

70. Sparks discusses 2-axis (two dimensional) mirror actuation for both switching (Ex. 1004 at 4:19-22) and power control (*Id.* at Abstract).

Regarding power control, Sparks includes:

a control system to control the mirrors so as to deliberately misalign the optical beam path 30 through the switch. By non-optimally aligning the optical beam path, the optical beam will be attenuated as it passes through the switch due to a reduction in the power of the beam coupled into the output fibre. This permits the switch to be utilised to achieve any desired optical beam power output less than the maximum.

Id. at 4:48-55.

71. The PHOSITA would be motivated to use the 2-axis system of Sparks within the system of Bouevitch for power control. First, power control was desirable generally and would be just as desirable after switching to 2-axis actuating mirrors for the benefits cited above. Bouevitch notes both the desirability of power equalization across spectral channels, and the need for devices that perform both power control and add/drop functions. (Ex. 1003 at 1:18-22, 1:50-54.) The patentee also recognized this, claiming that "spectral power-management capability is essential in WDM optical networking applications." (Ex. 1001 at 11:34-36.)

72. Second, the PHOSITA would be further motivated to utilize the 2-axis actuating mirror and power control feature of Sparks to address a need identified by Bouevitch. Bouevitch states “In WDM systems it is desirable to ensure that all channels have nearly equivalent power.” (Ex. 1003 at 1:21-22.) The power control feature of Sparks can be used to “maintain each of the power levels of the individual wavelength components (channels) at substantially the same level” (Ex. 1004 at 1:23-25.) To address this shared need, Sparks teaches:

controlled misalignment of the optical beam path so as to achieve a predetermined optical output power . . . If the optical system is being used as part of a WDM system, it is typical for the signal to be demultiplexed into the separate optical channels prior to input to the switch. If desired, each of the channels passing through the switch may be attenuated to whatever degree necessary to achieve the desired effect, e.g. equalisation of optical power across all channels.
(Ex. 1004 at 2:24-36.)

73. As such, the PHOSITA would have been motivated to utilize the 2-axis actuating mirror and power control feature of Sparks which were directly on point with addressing the need for all channels having nearly equivalent power as identified by Bouevitch.

74. Third, the PHOSITA would be further motivated to choose the Sparks solution of 2-axis tilting mirrors (and configure the optical arrangement such that one axis is associated with output port selection and second port is associated with power control) because choosing a 1-axis actuating mirror for both port selection and attenuation may result in dynamic fluctuations of power

crosstalk between ports as attenuation level is varied. Furthermore, in WSS applications where there are more than two output port options in the fiber array (Bouevitch recognized this, stating: Although only two input/output ports are shown to facilitate an understanding of this device, a plurality of such pairs of ports is optionally provided, Ex. 1003 at 5:32-34), the desire to eliminate dynamic crosstalk would have forced the PHOSITA to choose a switching solution that prevents that dynamic crosstalk. This can be achieved by 2-axis tilting mirrors as in Sparks.

(b) Claim 2

75. Claim 2 recites two elements: (1) “the wavelength-separating-routing apparatus of claim 1 further comprising a servo-control assembly, in communication with said channel micromirrors and said output ports,” and (2) the use of that assembly “for providing control of said channel micromirrors and thereby maintaining a predetermined coupling of each reflected spectral channel into one of said output ports.” Element (1) will be referred to as the “servo control assembly” element, and element (2) as the “coupling” element. Each element is discussed in order, below.

76. Servo Control Assembly: As discussed in the BRI section, above, the BRI of a “servo-control assembly” is a “feedback-based control assembly.” The ‘678 patent explains the way in which the servo-control assembly measures

the actual output power, and then uses that measurement in a feedback loop to further adjust the MEMS mirrors to ensure that the output power remains where it should.

77. Sparks discloses such a servo control assembly. Specifically, Sparks discloses a “closed-loop servo control system” employed for “controlling the movable micromirrors (16,26), which are fabricated using MEMS technology and are capable of two axis movement, to carefully align the beams” (Ex. 1004 at 4:39-45.) The “control system is used to control the mirrors so as to deliberately misalign the optical beam path 30 through the switch” to obtain “a reduction in the power of the beam” (*Id.* at 4:48-53.). To accomplish this power control, Sparks teaches “a control means 130 capable of receiving an input signal indicative of the power of an optical signal, and being arranged to control the functioning of said switching means for achieving misalignment of said optical beam path. A power measuring means 140 is arranged to provide a signal indicative of the power of the optical signal to the switching means.” (*Id.* at 4:61-67; *see also id.* at Fig. 4-Annotation 1, showing internal feedback loop):

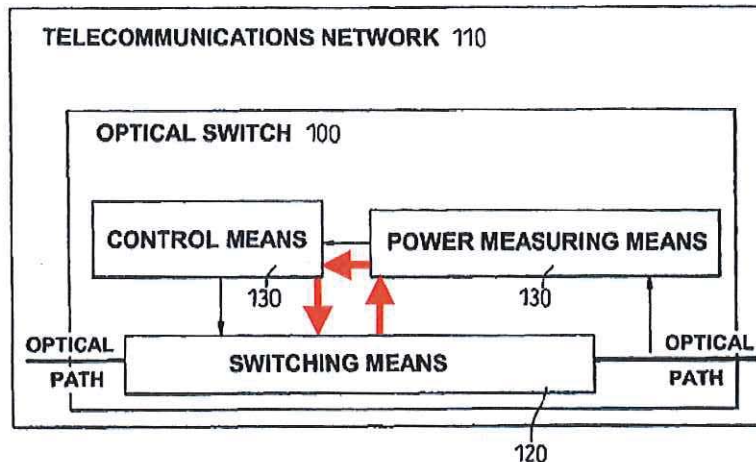

Fig. 4

78. It would have been obvious to the PHOSITA to try the internal feedback loop in Sparks for use in Bouevitch as an alternative to the "external feedback" for power control that Bouevitch explains should be eliminated. (Bouevitch, Ex. 1003 at 10:17-21.) This was obvious because the principal alternatives to provide such feedback would be the use of (1) internal or (2) external feedback. Using the Sparks internal feedback technique was known, and one of skill would be motivated to do so to avoid burdening the network controller with additional communication between network elements which would otherwise be required with external control. (*Id.*; see also the '679 Patent, Ex. 1001 at 12:9-15 ("The electronic circuitry and the associated signal processing algorithm/software for such processing unit in a servo-control system are known in the art."))

79. The source of feedback can be either internal or external, though at a high level they both operate identically. The measurement information is fed back to the controller which then readjusts the MEMS mirrors to the new settings to more accurately satisfy the switching requirement. If the measurement system is internal, then the network communications channel is not utilized and switch operates autonomously. But then the measurement hardware has to be introduced to the switch, which impacts its price. If the measurement system is external than no additional internal hardware is required, and the monitoring elements are typically already present within the network, hence it is more economical but burdens the network controller with additional communication between network elements.

80. Coupling: The second element of claim 2 recites the use of the servo control assembly “for providing control of said channel micromirrors and thereby maintaining a predetermined coupling of each reflected spectral channel into one of said output ports.” As discussed immediately below, both Sparks and Bouevitch describe how a goal of their respective servo control assemblies is to control the MEMS micromirrors to maintain a predetermined coupling of each mirror’s spectral channel into an output port.

81. Sparks discusses its use of servo-control to achieve a particular degree of coupling of a channel to an output port. Specifically, Sparks states “FIG.

2a illustrates how the optical beam 30 would normally be coupled into the optical fiber core 4a, which is surrounded by optical fibre cladding 4b, by the focussing lens 22. If, in accordance with an embodiment of the present invention, the optical beam path is misaligned, e.g. either to misalignment of one of the mirrors 16, 26 or movement of the lens 22, then FIG. 2b illustrates how only a portion of the beam 30 will be coupled into the optical fibre core 4a. Consequently, only the fraction of the beam profile 30 coupled into the output forms the output signal, and hence the optical signal is attenuated.” (Ex. 1004 at 5:1-11.) Sparks teaches that “the optical switch is calibrated such that a predetermined misalignment produces a predetermined attenuation”. (*Id.* at 2:52-53; *see also id.* at 3:15-22.) Hence, a predetermined coupling of each reflected spectral channel into an output port is maintained.

82. Similarly, Bouevitch discusses the use of MEMS mirrors for a Dynamic Gain Equalizer (DGE) function, in which output power is determined by the coupling angle of the light beams reflected from those mirrors to output ports. Bouevitch teaches that the coupling angle is predetermined in order to achieve a particular power level. Bouevitch states that “[e]ach sub-beam...is selectively reflected back to the spherical reflector 910 at a predetermined angle,” by the modifying means [e.g., MEMS mirrors], and that “[v]ariable attenuation is provided by the modifying means.” (Ex. 1003, 12:55-59.) “The degree of

attenuation is based on the degree of deflection provided by the reflector (i.e., the angle of reflection).” (*Id.*, 7:35-37.) The coupling angle created by that deflection is predetermined by the servo-control for the MEMS mirrors as that servo-control works to achieve a particular target power level by moving the mirrors.

(c) Claim 3

83. Claim 3 recites “The wavelength-separating-routing apparatus of claim 2 wherein said servo-control assembly comprises a spectral monitor for monitoring power levels of said spectral channels coupled into said output ports, and a processing unit responsive to said power levels for providing control of said channel micromirrors.” Sparks’ disclosure of a servo-control assembly is discussed in § VI(b), above Sparks’ use of a “spectral monitor” and a processing unit within that assembly for monitoring and controlling is discussed in turn, below.

84. Spectral Monitor: The spectral monitor portion of claim 3 requires the control unit to “include[] a spectral monitor for monitoring power levels of selected ones of said spectral channels, and a processing unit responsive to said power levels for controlling said beam deflecting elements.” The BRI for the term “spectral monitor” is “a device for measuring power in a spectral channel.”

85. Sparks discloses power measuring means 130 for measuring the power of a measuring power in a spectral channel and using the measured power

of the spectral channel for controlling the actuation of the mirrors to provide greater or lesser misalignment with an optical port to achieve a predetermined power output for a particular spectral channel. (Ex. 1004 at 2:46-62.) As depicted in Fig. 4 of Sparks, power measuring means 130 measures a spectral channel along an optical path and communicates with the control means 130 for closed loop control. Sparks states that “both the input and the output optical signal to the switch could be measured in order to directly indicate the degree of the attenuation of the optical signal as it passes through the switch. This information could be used to provide a closed loop feedback control system to ensure that the desired degree of attenuation is achieved for each optical signal (or channel).” (*Id.* at 2:59-65.) The PHOSITA would understand that because an intended change in misalignment for one spectral channel can be indicated by the power measurement made at the input and output, that the power changes in a single channel, and every channel, can be monitored.

86. It would also be obvious to a PHOSITA to use the spectral monitor of Sparks within the Bouevitch, which otherwise disclosed an external monitor and feedback. As the patentee stated in the ‘678 patent, a “skilled artisan will know how to implement a suitable spectral monitor along with an appropriate processing unit to provide a servo-control assembly in a WSP-S apparatus according to the present invention, for a given application.” (Ex. 1001 at 12:12-

15.) PHOSITA would also understand that the feedback from the monitor would need to be processed to turn the power measurement into control signals in the form of analog actuation voltages for the MEMS mirrors. This control loop typically operates continuously, with the OPM periodically measuring (e.g. every 15 minutes) the wavelength channel power distribution and the switch controller readjusting its actuation mirrors to best meet some power control goal, e.g., target power flatness. (Ex. 1011, Doerr et al., An Automatic 40-Wavelength Channelized Equalizer, IEEE Photonics Technology Letters, Vol., 12, No. 9, (Sept. 2000), and references therein (especially 9 and 10).) This operation completes the feedback of the MEMS servo control. For example, the processor would need to determine the amount of tilt change required on the mirrors to adjust the power output. The PHOSITA had ample motivation to combine the Sparks feedback loop within Bouevitch because the PHOSITA would appreciate that the feedback-driven control of Sparks would improve the precision of the mirror-based switching system of Bouevitch. As a contemporary document in the optical switching field stated, "the actuation method for [micromirrors] is often imprecise. To achieve a variable switch, it is typically necessary to use a very high level of optical feedback." (Hoen, Ex. 1009 at 2:4-9.)

87. Processing Unit: Claim 3 recites "The wavelength-separating-routing apparatus of claim 2 wherein said servo-control assembly comprises a

spectral monitor for monitoring power levels of said spectral channels coupled into said output ports, and a processing unit responsive to said power levels for providing control of said channel micromirrors.” Bouevitch must contain a processing unit for controlling the tilt of the channel mirrors (50, 51) in the MEMS array (50), since individual mirrors in the array require an actuation voltage to be supplied. The role of the processing unit is to provide this plurality of voltages, which is required to independently control individual mirrors in the array. The applied voltages are determined according to the specific switching requirement, which specifies for each channel its output port assignment and attenuation control to balance out all the wavelength channel powers. The processing unit associated with the optical add-drop apparatus typically interacts with the optical network level controller, receiving from it optical switching assignments, and internally applies the MEMS mirror voltages to control the mirror tilts and complete the switching assignment.

88. In typical networks, the entire optical network is managed from a centralized operations control center. When the network is required to dynamically change, commands are issued by the operations control center to the network elements such as the WSS. The WSS received the message and has to perform its function according to a defined protocol, changing the switching state,

and then signaling back to the ops center that the switching is completed and the channel turn on can commence.

89. Thus, each network element, such as the WSS, necessarily has an internal controller/processor with firmware in sync with the network operations. Individual mirrors could not otherwise be actuated to align to selected output fiber ports and maintained with sufficient accuracy necessary for the switching operation. Accordingly, a processing unit was necessary.

90. Moreover, Sparks explicitly describes a processing (controller) unit for its micromirrors. Specifically, Sparks discloses “an optical switch 100 as part of a telecommunications network 110, the switch having an optical path, a switching means 120 [having] a control means 130 capable of receiving an input signal indicative of the power of an optical signal, and being arranged to control the functioning of said switching means for achieving misalignment of said optical beam path. A power measuring means 140 is arranged to provide a signal indicative of the power of the optical signal to the switching means.” (Sparks, Ex. 1004 at 4:59-67 & Fig. 4.)

91. To the extent Bouevitch does not already disclose a “processing unit,” adding the processing unit of Sparks (or any other known processing unit) to Bouevitch would have been obvious to PHOSITA because processing units such as microprocessors were well known elements with almost universal

applicability in the field of photonics devices that are adaptable in response to a request. These processing units are mandatory for the system because an optical switch is required to communicate using a protocol with a network level controller, receiving switching commands and responding accordingly. The PHOSITA could have added such a processing unit to Bouevitch with no change in the unit's functions (to act as a controller of electronic elements). Adding this processing unit (such as in the form of a microprocessor) would have yielded the predictable result of electronic control to one of ordinary skill in the art—a microprocessor-controlled COADM. The processing unit would communicate with the optical network controller on the one hand, and set the internal switching mechanism (analog electrical voltages applied to MEMS mirrors) on the other hand. The communication to the network controller is determined by the protocols set forth by the network controller, and the switching function has to be completed in a fixed time requirement and reported back to the network. All of these requirements would have motivated the PHOSITA to add the processing unit of Sparks to Bouevitch to any extent that a processor receiving feedback was not inherent in Bouevitch.

92. In addition, it would be obvious to PHOSITA to add a processing unit to Bouevitch, including adding the Sparks processing unit. The Bouevitch device is required to function with some type of processing unit. The “selective

switching” that Bouevitch performs with its MEMS mirrors would need to be performed by some type of processing unit, accepting commands for switching state change from a remote network controller and in response issuing the actuation controls required for completing the switching function.

93. As shown above, Sparks demonstrates that it was known at the time of the ‘678 Patent to use a spectral monitor to monitor one or multiple spectral channels and use a processing control unit to control a servo-control assembly that actuates beam-deflecting mirrors based on the power level information. The PHOSITA would have understood that implementing the known channel monitoring and closed loop servo-control of Sparks referenced above would be a straightforward and predictable change that would help achieve the equalization of the power levels of channel as identified in Bouevitch (Bouevitch, Ex. 1003 at 1:18-22) and solved by Sparks (Ex. 1004 at 1:9-25). As such, the PHOSITA would be motivated to implement the channel monitoring and closed loop servo-control with 2-axis deflecting mirrors as made known by Sparks in the system of Bouevitch.

(d) Claim 4

94. Claim 4 recites “The wavelength-separating-routing apparatus of claim 3, wherein said servo-control assembly maintains said power levels at a predetermined value.” Sparks teaches “[a]n optical switch comprising switching

means arranged to switch an optical signal by redirection of the optical beam path of said signal, wherein said optical switch is arranged to misalign the optical beam path so as to **provide a predetermined optical output power.**” (Ex. 1004 at Abstract, emphasis added.) Sparks further teaches that a “closed-loop servo control system is employed” (*id.* at 4:39-40) and that the feedback information is used “to ensure that the desired degree of attenuation is achieved for each optical signal (or channel).” (*Id.* at 2:62-65.) Hence, a servo-control assembly maintains said power levels at a predetermined value.

95. It would have been obvious to try the predetermined power settings of Sparks within Bouevitch to achieve the predictable results of power control at predetermined levels. Sparks demonstrates that it was known at the time of the ‘678 Patent to monitor one or multiple spectral channels and use a servo-control assembly to maintain power of the channel(s) at predetermined power levels. ” (Ex. 1004 at 1:23-25.) The PHOSITA would have understood that implementing the known channel monitoring and closed loop servo-control of Sparks referenced above would be a straightforward and predictable change that would help achieve the equalization of the power levels of channel as identified in Bouevitch (Bouevitch, Ex. 1003 at 1:18-22) and solved by Sparks (Ex. 1004 at 1:9-25).

(e) Claim 9

96. Claim 9 recites “The wavelength-separating-routing apparatus of claim 1 wherein each channel micromirror is continuously pivotable about one axis.” As discussed above in §§ IV.C and VI(a)(vi), Bouevitch discusses 1-axis micromirrors that are continuously pivotable. Sparks discloses mirrors that are continuously-pivotable in two axes under Grounds 1 and 2 (Bouevitch+Sparks and Bouvitch+ Sparks +Lin), and thus the same mirrors—which are also pivotable in one axis—are obvious as disclosed by Sparks. (§ VI(a)(vi).)

(f) Claim 10

97. Claim 10 recites “The wavelength-separating-routing apparatus of claim 1 wherein each channel micromirror is continuously pivotable about two axes.” As discussed above in §§ V.A & VI(a)(vi), channel micromirrors continuously pivotable about two axes were disclosed by Sparks and would have been obvious to PHOSITA in light of Petitioner’s Grounds 1 or 2.

(g) Claim 13

98. Claim 13 recites “The wavelength-separating-routing apparatus of claim 1 wherein said fiber collimators are arranged in a one-dimensional array.” It is noted that the claim does not recite that the array cannot be a two-dimensional array. Thus, any array of fiber collimators (e.g., a two-dimensional array) necessarily includes a one-dimensional array.

99. Bouevitch teaches that a “front-end unit” can carry many beams of light by including an array (Ex. 1003 at 6:1-5), and further discloses fiber collimators that are lined up to match that front-end unit, and where the collimators are thus also arranged in a 1-D array. Specifically, Bouevitch describes how “light transmitted to and from the output and input optical waveguides is focused/collimated, e.g., through the use of microcollimators,” and how these collimators can be configured to match a “front-end unit (e.g., as shown in FIGS. 2a or 2b), which is in the form of an array [to couple] input/output waveguides.” (Ex. 1003, 13:9–18; Figs. 2a, 2b, 9b-9d.) In this and several related embodiments, Bouevitch teaches the arrangement of fiber collimators in a one-dimensional array. (*See id.*, 13:9–14:14, 5:22-42.) Sparks also discloses arrays of receiving ports, which as discussed above must necessarily include a one-dimensional array. (Ex. 1004 at 4:33-35.)

(h) Claim 17 – Grounds 1, 2, 3, and 4

100. Claim 17 recites “The wavelength-separating-routing apparatus of claim 1 wherein each said wavelength-separator comprises an element selected from the group consisting of ruled diffraction gratings, holographic diffraction gratings, echelle gratings, curved diffraction gratings, and dispersing gratings.” I discuss below four separate grounds under which claim 17 is obvious.

101. Under Grounds 1 and 2, it would have been obvious to use any of the types of wavelength-selective devices recited in claim 12, as each type was known in the prior art (*e.g.*, *see* Sparks, Ex. 1004 at 5:36-38 stating that the switch can be “a controllable diffraction grating” type), the PHOSITA knew them to be interchangeable as wavelength-selective devices, and each was one of a small set of possible choices that would have been obvious to try. All these dispersive elements are known to separate different wavelengths due to their wavelength dependence in operation (whether diffraction or refraction). For example, Bouevitch references the use of prisms as wavelength-selective devices through Bouevitch’s incorporation by reference of Patel. (Ex. 1031, incorporated in Bouevitch, Ex. 1003 at 1:37-39.) Patel notes that prisms are one type “frequency-dispersive mediums” that include diffraction gratings. (Ex. 1031 at 3:20-36.) In addition, these options for wavelength-selective devices are discussed in Ex. 1005, Born et al., PRINCIPLES OF OPTICS, at 407-414 (6th Ed., Pergammon Press 1984).

102. Alternatively, it was also obvious to combine Bouevitch+Sparks (or Bouevitch+Sparks+Lin) with other known teachings of specific types of wavelength-selective device for WDM devices. For example, Dueck discusses “ruled diffraction gratings,” and Ranalli discusses grating prisms. (Dueck, Ex. 1021 at 6:26-30; *see also* Ranalli, Ex. 1027 at 6:33-36.) I will refer to the

combination of Bouevitch+Sparks+Dueck as Ground 3 and Bouevitch+Sparks+Lin+Dueck as Ground 4. All these elements are known to disperse wavelengths. Diffraction gratings, whether in the form of ruled, holographic, or Echelle are all conforming to the same diffraction formula and same physics. They only differ in their manufacturing technique. It would be obvious to try such a ruled diffraction grating in the devices of Bouevitch and Sparks under Grounds 3 or 4, and PHOSITA would be motivated to do so because Dueck describes its grating as part of the “best mode” of separating wavelengths in WDM devices, which include the Bouevitch and Sparks devices. (Dueck, Ex. 1021 at 6:26-30.)

(i) Claim 19

103. Claim 19 recites “The wavelength-separating-routing apparatus of claim 1 wherein each output port carries a single one of said spectral channels.” Bouevitch discloses this limitation, because it describes dropping subset channel λ_2 from the combined set of channels λ_1 and λ_2 , and then directing λ_2 out the OUT DROP output port, while λ_1 is directed to a different output port called OUT EXPRESS. (Ex. 1003, 14:27-15:18; § VI(a)(vi).) Each mirror in the MEMS array (elements 51 and 52 for Fig. 11-Annotation 2, above) reflects a separate, corresponding beam of light (channels λ_1 & λ_2 respectively), including operations where the channel reflected by mirror 51 is passed through, and the channel

reflected by 52 is dropped. (Boueitch, Ex. 1003, 14:52-63, Fig. 11.) I have included Figure 11-Annotation 3 from Boueitch below. In this figure, beam-deflecting mirror 52 (annotation “A”) directs the channel associated with λ_2 along a different path (“B”) than the λ_1 channel and finally out of “OUT DROP” port 3 of 80b (“C”). Accordingly, the Figure illustrates the path that a spectral channel, once separated from the other channel, would follow to be dropped through one output port while another channel exists through the other output port. (*Id.*, Fig 11, 14:60-65.)

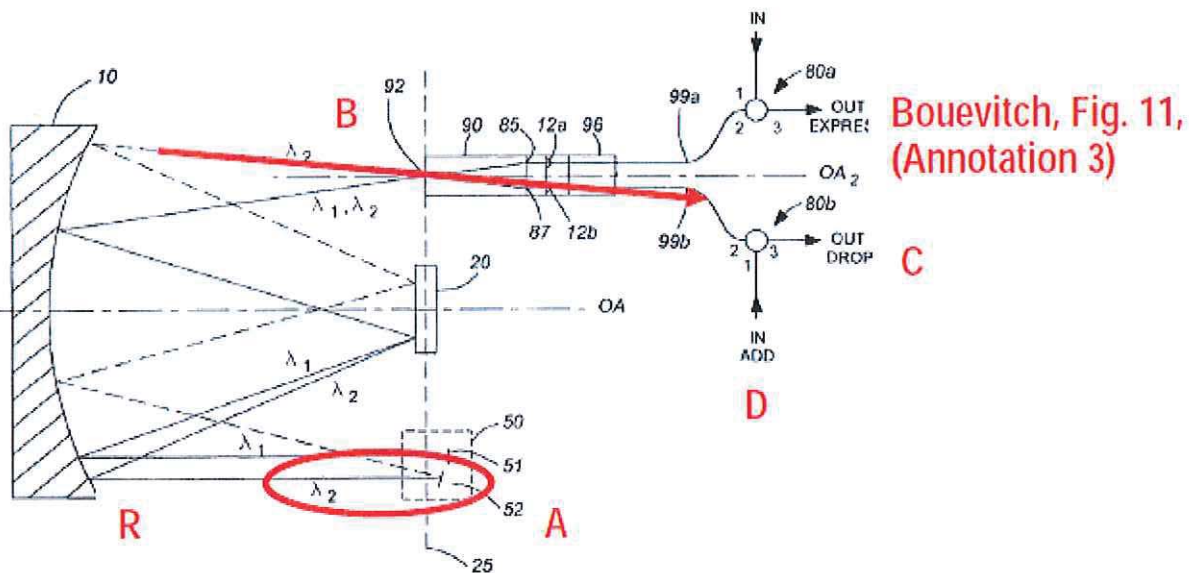

(j) Claim 20

104. Claim 20 recites “The wavelength-separating-routing apparatus of claim 19 further comprising one or more optical sensors, optically coupled to said output ports.” The BRI of “optical sensor” is “a device that measures an optical characteristic”.

105. Sparks teaches “a control means 130 capable of receiving an input signal indicative of the power of an optical signal, and being arranged to control the functioning of said switching means for achieving misalignment of said optical beam path. A power measuring means 140 is arranged to provide a signal indicative of the power of the optical signal to the switching means.” (Sparks, Ex. 1004 at 4:61-67.) As shown in Fig. 4 of Sparks, annotated below, the power measuring means 140 taps the output of the switching means 120 to provide an input signal, to the control means 130, from the output path of the switching means 120.

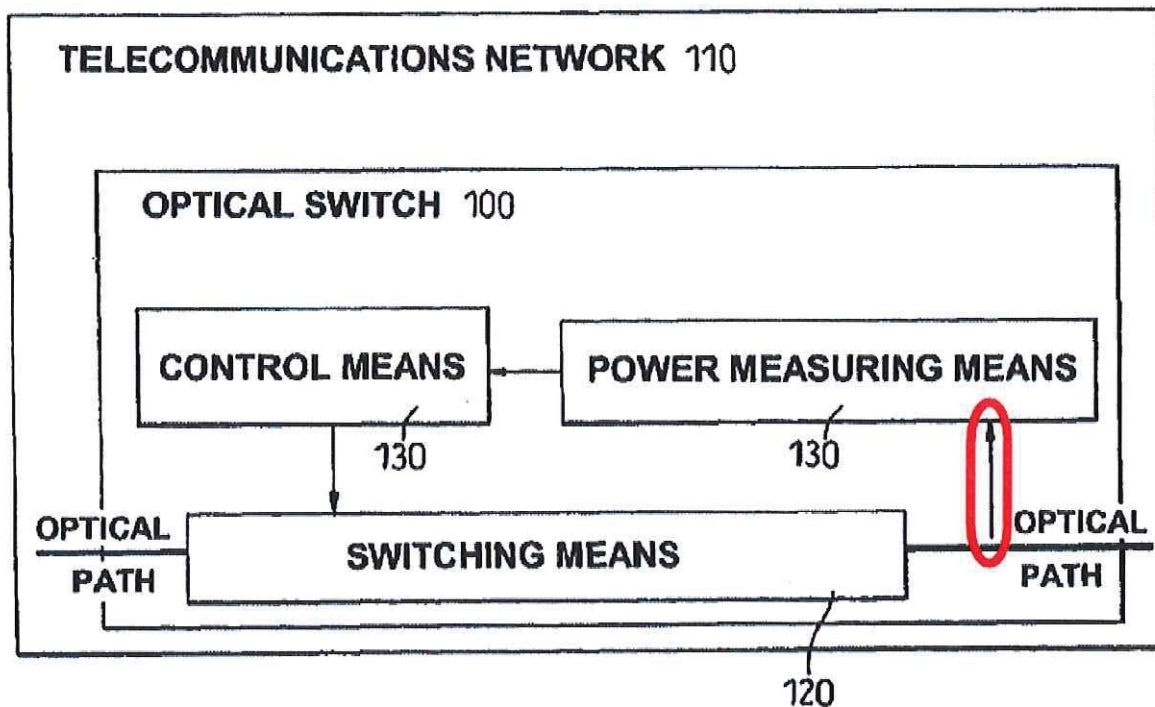

Fig. 4

106. Sparks states that “both the input and the output optical signal to the switch could be measured in order to directly indicate the degree of the attenuation of the optical signal as it passes through the switch. This information could be used to provide a closed loop feedback control system to ensure that the desired degree of attenuation is achieved for each optical signal (or channel).” (Ex. 1004 at 2:59-65.)

107. As such, Sparks discloses a device for measuring the power of an optical signal (at least for the purpose of feedback control), the device coupled with an output port and provides at least one optical sensor optically coupled to an optical port. The PHOSITA would have understood that implementing the known optical power monitoring and closed loop servo-control of Sparks referenced above, in Bouevitch, would be a straightforward and predictable change that would help achieve the equalization of the power levels of channel as identified in Bouevitch (Ex. 1003 at 1:18-22) and solved by Sparks (Ex. 1004 at 1:9-25). As such, the PHOSITA would be motivated to implement the optical power measuring device as made known by Sparks in the system of Bouevitch. The PHOSITA would be motivated to exchange the sensor placement in Bouevitch with that of Sparks, at the output of the switch, because doing so would provide a more accurate measurement of the device’s actual output power in fiber at the output port. Bouevitch’s positioning of sensors behind its beam-folding mirror

(prior to the output fibers) would provide less accurate measurements of the power levels in those fibers than Sparks' sensors, which are coupled to output of the switch. There is greater confidence in Sparks' direct power measurement versus other indirect measurements (such as beam deflection or mirror tilt), which require knowledge of the correspondence between the measured metric and the actual power. That correspondence may be degraded over time as the WSS ages, whereas direct power measurement remains always valid.

(k) Claim 21

(i) Preamble

108. The preamble to claim 21 recites "A servo-based optical apparatus comprising:" Because claim 2 recites a "servo"-based optical "wavelength separating-routing" apparatus, claim 2 also covers the broader "servo-based optical apparatus" of claim 21, as an optical apparatus is broader than a WSR. Thus, the preamble for claim 21 is disclosed under both Grounds 1 and 2 for the same reasons that those grounds disclose claim 2. (*See* § VI(b), above.)

(ii) Claim element 21[a]-21(c)

109. Claim 21 is an independent claim that closely resembles claim 1. The first three elements of claim 21 (recited as "[a]" to "[c]" here) are identical to elements [a]-[c] of claim 1. These elements are disclosed by Bouevitch for the same reasons set forth in claim 1. (§ VI(a).) To avoid unnecessary repetition, those arguments are not copied here. They are incorporated by reference. As in claim 1,

I again point to Sparks+Bouevitch under Ground 1 as making claim 21 obvious. Because claim 1's "continuously" element is not recited in claim 21, I will not analyze claim 21 under Ground 2 of Sparks+Bouevitch+Lin. The remaining elements of claim 21 are discussed below.

(iii) Element 21[d]—array of controllable micromirrors

110. The fourth limitation to claim 21 recites "a spatial array of channel micromirrors positioned such that each channel micromirror receives one of said spectral channels, said channel micromirrors being individually controllable to reflect said spectral channels into selected ones of said output ports[.]" The main substantive difference between element 21[d] and 1[d] is that the Patentee did not amend element 21[d] to narrow it to add that the mirrors are "pivotal about two axes" and to add the intended use term regarding power control as in 1[d]. Thus, element 21[d] is disclosed by Bouevitch even without Sparks, because Bouevitch's ROADM uses individual control of MEMS mirrors with one axis of rotation for switching channels into output ports. (*E.g.*, Bouevitch, Ex. 1003, 14:14-15:18, 7:23-37.)

(iv) Element 21[e]—servo-control

111. The fifth limitation of claim 21, identified here as 21[e], recites "a servo-control assembly, in communication with said channel micromirrors and said output ports, for maintaining a predetermined coupling of each reflected

spectral channel into one of said output ports.” Element 21[e] is substantively identical to apparatus claim 2 and is disclosed by each of Grounds 1 and 2 for the same reasons as for claim 2. (*See* § VI(b), above.)

(l) Claim 22

112. Claim 22 recites “The servo-based optical apparatus of claim 21 wherein said servo-control assembly comprises a spectral monitor for monitoring power levels of said spectral channels coupled into said output ports, and a processing unit responsive to said power levels for providing control of said channel micromirrors.” Claim 22 recites identical claim language as apparatus claim 3, and is thus disclosed by each of Grounds 1 and 2 for the same reasons as for claim 3. (*See* § VI(c).)

(m) Claim 23

113. Claim 23 recites “The servo-based optical apparatus of claim 22 wherein said servo-control assembly maintains said power levels at a predetermined value.” Claim 22 recites identical claim language as apparatus claim 4, and is thus disclosed by each of Grounds 1 and 2 for the same reasons as for claim 4. (*See* § VI(d).)

(n) Claim 27

114. Claim 27 recites “The servo-based optical apparatus of claim 21 wherein each channel micromirror is continuously pivotable about at least one axis.” Claim 27 is substantively identical to claim 9 except for claim 27’s

recitation of “servo-control” (from parent claim 21), which claim 9 lacks. Thus, for the reasons discussed above for limitation 21[e] and claim 9, claim 27’s use of servo-controlled micromirrors pivotable about at least one axis was obvious to PHOSITA in light of either Grounds 1 or 2. (*See* §§ VI(a)(vi)-VI(a)(viii).)

(o) Claim 28

115. Claim 28 recites “The servo-based optical apparatus of claim 21 wherein each channel micromirror is a silicon micromachined mirror.” Claim 28 is substantively identical to claim 12 except for the recitation of “servo-control” (from parent claim 21). Thus, for the reasons discussed above for claims 21 and 12, using silicon micromachined mirrors as channel micromirrors would have been obvious to PHOSITA. (*See* §§ VI(l) & VI(g).)

(p) Claim 29

116. Claim 29 recites identical claim language as apparatus claim 17 except for the recitation of “servo-control” (from parent claim 21) and including a “prism” instead of a grating. Thus, claim 29 is disclosed by each of Grounds 1, 2, 3, and 4 for the same reasons as for claims 17 and 21. (*See* §§ VI(i) and VI(l).) Such prisms were known to be used as wavelength separators as early as the 18th century (*See, e.g.,* Ex. 1046, *Sir Isaac Newton, Opticks or a treatise of the reflections, refractions, and inflections and colors of light*, at Figs. 13, 24 (1730)).

(q) Claim 44

117. Claim 44 is an independent claim that closely resembles claim 1. Elements [b] and [c] of claim 44 are identical to elements [b] and [c] of claim 1. These elements are disclosed in Bouevitch for the same reasons set forth in claim 1. (*See* § VI(a).) The few differences between the other two claim elements of claim 44 (identified as 44[a] and [d]) and claim 1 are small and also obvious under both of Petitioner’s Grounds 1 and 2, as explained below. To the extent claim 44’s preamble is limiting, it is also disclosed by Grounds 1 and 2.

118. The only differences between elements 1[a] and 44[a] are the additional limitations in 44[a] of a pass-through port and at least one drop port, as well as that the collimators of 44[a] are part of “an array.” The only differences between elements 1[d] and 44[d] is the additional pass-through port in 44[d] for receiving a subset of spectral channels. Grounds 1 and 2 disclose all of these limitations.

(i) Preamble

119. Turning first to the preamble to claim 44, the preamble recites “An optical system comprising a wavelength-separating-routing apparatus, wherein said wavelength-separating-routing apparatus includes.” Thus, claim 44’s preamble simply embeds the use of the wavelength-separating-routing apparatus of claim 1 within a larger optical system. One such use of a ROADM/DGE routing apparatus is disclosed by Bouevitch and Sparks, each of which suggests

using their respective optical switches within a WDM network system. (Bouevitch, Ex. 1003 at 1:18-30; Sparks, Ex. 1004 at 1:19-25, 2:30-33, 4:9:14.) The preamble of claim 44 is also obvious, because the point of implementing a ROADM/DGE is to use it within an optical network. One option for the switching elements required to perform this switching operation is a WSS with multiple output port counts. The output ports are then assembled to network links.

(ii) Claim element 44[a]—fiber collimator ports: input, outputs, pass-through, and drops

120. The first limitation to claim 44 (identified here as 44[a]) recites “an array of fiber collimators, providing an input port for a multi-wavelength optical signal and a plurality of output ports including a pass-through port and one or more drop ports[.]” Bouevitch discloses the use of collimators to provide all these ports.

121. In order to transmit light “to and from the output and input,” Bouevitch discloses “the use of microcollimators,” which the PHOSITA would recognize are types of fiber collimators. Examples of fiber collimators, such as ball lenses, GRIN lenses, Fresnel lenses, and refractive lens arrays were all discussed earlier. (Bouevitch, Ex. 1003, 13:9-13; § (a)(iii)VI(a)(iii)). The ‘678 patent similarly notes that “[m]oreover, a fiber collimator is typically in the form of a collimating lens (such as a GRIN lens) and a ferrule-mounted fiber packaged together in a mechanically rigid stainless steel (or glass) tube.” (Ex. 1001 at 9:19-

23.) These fiber collimators are shown as providing both input and output ports. (*See* § VI(a)(iii), above.) Bouevitch also discloses that the output port can be used as the pass-through port of element 44[a] when the “modifying means” of the Bouevitch’s ROADM allows a light beam to pass through unchanged. (Ex. 1003 at 6:20-25). Bouevitch also teaches another output port in the form of a “drop port” of element 44[a] as the “OUT DROP” port in element 80b port 3. I have labeled this port as “D” in Fig. 11-Annotation 1, in § VI(a)(iii), above. Bouevitch also discloses having multiple beams of light “designed as an array.” (Ex. 1003 at 6:1-5.) Moreover, Bouevitch also discloses additional beams of light multiplexed to front end optics. (*Id.*, 10:56-61 (“wherein each band has its own corresponding in/out/add/drop ports.”)) This allows several independent switching functions to be incorporated in a single switching apparatus, thereby saving on component count and cost.

(iii) Element 44[d]—control power of spectral channels into output ports including a pass-through port

122. The fourth limitation to claim 44 recites “a spatial array of channel micromirrors positioned such that each channel micromirror receives one of said spectral channels, said channel micromirrors being pivotal about two axes and being individually and continuously controllable to reflect corresponding received spectral channels into any selected ones of said output ports and to control the power of said received spectral channels into said output ports,

whereby said pass-through port receives a subset of said spectral channels.” Other than the addition of “whereby said pass-through port receives a subset of said spectral channels,” claim 44[d] is substantively identical to claim 1[d] and is obvious for the same reasons. (*See* § VI(a)(vi).) As for element 44[d]’s “pass-through port,” Bouevitch discloses this use of a pass-through port of element 44[d]. Bouevitch gives an example where a subset of the spectral channels (channel λ_1) is passed through to the output port unchanged. (Ex. 1003, 14:39–65.) In a simple ROADM which is present at a network node with only two links attached (i.e. node is placed on an intermediate point of a line), no switching operation is required, just the add-drop of a select few channels and the remaining channels are to continue to propagate through the node. This traffic is thus routed from the ROADM in port directly through to the out port, without incurring excess loss or delay.

(r) Claim 45

123. Claim 45 recites identical claim language as apparatus claim 2 (other than being a dependent claim of claim 44, instead of claim 1), and is thus disclosed by each of Grounds 1 & 2 for the same reasons as for claims 44 & 2. (*See* § VI(b).)

(s) Claim 46

124. Claim 46 recites identical claim language as apparatus claim 3 (other than being a dependent claim of claim 45, instead of claim 1), and is thus disclosed by each of Grounds 1 & 2 for the same reasons as for claims 45 & 3. (See §§ VI(s) and VI(c).)

(t) Claim 51

125. Claim 51 recites identical claim language as claim 12 (other than depending from claim 44), and is thus disclosed by each of Grounds 1 & 2 for the same reasons as for claims 44 & 12. (See §§ VI(r) and VI(g).)

(u) Claim 53

126. Claim 53 recites identical claim language as claim 17 (other than depending from claim 44 and reciting a “prism” instead of a grating), and is disclosed by Grounds 1-4 for the same reasons as for claims 44 & 17. (See §§ VI(r) and VI(i).)

(v) Claim 61

127. Claim 61 is a method claim version of claim 1 with few differences to claim 1 save replacing the claim term “individually and continuously controllable” of claim 1 with “*dynamically* and continuously controlling.” Claim 61 is otherwise broader, lacking the “collimator” limitation of claim 1.

128. The preamble of claim 61 recites “A method of performing dynamic wavelength separating and routing.” Bouevitch describes a method for

wavelength separating, specifically, a method for operating a device that separates (spatially disperses) a light beam according to wavelength and routes the separated sub-beam along a designated pathway. (Ex. 1003, Abstract; *see also id.*, 2:28-31, 8:8–41; 5:15–20; 14:14-21; Figs. 1, 11; 3:9-63). The “dynamic” portion of this preamble is also disclosed by Bouevitch and is discussed below for element 61[d] § VI(w)(v). As is the case for claims 1, 21 and 44, claim 61 is obvious under both Grounds 1 and 2, and I incorporate by reference my discussion of those claims here to avoid replication.

(i) Claim element 61[a]—receive signal from input

129. The first limitation to claim 61 recites “receiving a multi-wavelength optical signal from an input port[.]” Bouevitch discloses this by teaching how its ROADM operates to add/drop different wavelengths that are multiplexed together as received in the input port. (*See Ex. 1003, 1:18-30, 14:14-15:18; § VI(a)(iii).*)

(ii) (Element 61[b]—separating the multi-wavelength signal into spectral channels

130. The second limitation to claim 61 recites “separating said multi-wavelength optical signal into multiple spectral channels.” Bouevitch discloses this step at Figure 11, where diffraction grating 20 spatially **separates combined channels $\lambda_1\lambda_2$** (“A” at Fig. 11-Annotation 2, above) **into spatially-separated**

channels. (*See, e.g.*, § VI(a)(iv) (element 1[b]), above, Fig. 11-annotation 1 at “B”, in § VI(a)(iii); Bouevitch, Ex. 1003, 14:48-53, 8:10–22.)

(iii) Element 61[c]—focus spectral channels onto array of beam-deflecting elements

131. Claim 61’s third limitation (61[c]) is “focusing said spectral channels onto a spatial array of corresponding beam-deflecting elements, whereby each beam-deflecting element receives one of said spectral channels[.]” As discussed for claim element 1[c], Bouevitch discloses the recited “focusing” using spherical reflector 10 in Figure 11-Annotation 2 at “R,” (§ VI(a)(v), above), to focus each channel onto a corresponding beam deflecting element (mirror 51 or 52). (*Id.*; Ex. 1003, Figs. 11, 6a, 15:7-11, 14:14-20, 48-55, Fig. 1, 8:46–49; *see also* Sparks, Ex. 1004, 12:43-50.)

(iv) Element 61[d]—dynamically and continuously controlling direction and power of spectral channels

132. The fourth limitation to claim 61 recites “dynamically and continuously controlling said beam-deflecting elements in two dimensions to direct said spectral channels into any selected ones of said output ports and to control the power of the spectral channels coupled into said [sic] selected output ports.” The BRI of controlling “in two dimensions” means controlling “in two axes.” The BRI of “continuously controlling” is “able to effect changes with fine precision.”

133. The only substantive difference between claim 61[d] and claim 1[d] is the addition in 61[d] of “controlling *dynamically* and continuously.” Thus, other than the word “dynamically,” the method step of claim 61[d] is disclosed by each of Grounds 1 and 2 for all the reasons discussed for claim 1[d], above. (See § VI(a)(vi))

134. The plain and ordinary meaning of “dynamically” controlling in the context of the ‘678 Patent is controlling “during operation.” (See Ex. 1001, 3:22-23 (contrasting routing that is fixed during operation: “the [prior art] wavelength routing is intrinsically static, rendering it difficult to dynamically reconfigure these OADMs.”).)

135. Both Bouevitch and Sparks teach dynamic control during operation. Bouevitch’s device can be used as a “dynamic gain equalizer and/or configurable add/drop multiplexer,” which includes dynamic control of the mirrors that perform those actions. (Ex. 1003 at 2:24-25.) Sparks teaches closed-loop 2-axis control (Ex. 1004 at 4:39-47) which the PHOSITA would have understood to mean making adjustments to the deflection of the beam in response to real-time monitoring of the channel power level.

(w) Claim 62

136. Claim 62 is a method version of apparatus claim 2, and recites “The method of claim 61 further comprising the step of providing feedback

control of said beam-deflecting elements to maintain a predetermined coupling of each spectral channel directed into one of said output ports.” The only substantive difference between claim 62 and claim 2 is that claim 62 uses “feedback control” instead of a “servo-control assembly.” However, the PHOSITA would understand that these two terms are equivalent. Thus, claim 62 is obvious for the same reasons as for claim 2. (See § VI(b), above).

(x) Claim 63

137. Claim 63 is substantively identical to claim 4, reciting “The method of claim 62 further comprising the step of maintaining power levels of said spectral channels directed into said output ports at a predetermining value.” Thus, claim 63 is obvious for the same reasons as for claim 4. (See § VI(d), above).

(y) Claim 64

138. Claim 64 is a method version of claim 19 and recites “The method of claim 61 wherein each spectral channel is directed into a separate output port.” This one-channel-per-port scenario is merely a specific case of the normal operation of the ROADM disclosed in Bouevitch, where each channel happens to go to a different output port. Claim 19 equivalently recites “wherein each output port carries a single one of said spectral channels.” Thus, claim 64 is obvious for the same reasons as for claim 19. (See § VI(j), above.)

(z) Claim 65

139. Claim 65 is similar to claim element 44[d], and recites “The method of claim 61 wherein a subset of said spectral channels is directed into one of said output ports, thereby providing one or more pass-through spectral channels.” The last part of element 44[d] similarly recites “whereby said pass-through port receives a subset of said spectral channels.” Thus, for the same reasons discussed above for Claim 44[d], claim 65 is obvious. (See § VI(r)(iv)).

140. Bouevitch also describes additional sets of output ports (pass-through and drop ports) in scenarios where the ROADM switches two sets of frequency bands:

Optionally, second, third, forth, . . . etc. multiplexed beams of light are launched into the front-end unit **605**. In fact, this optical arrangement is particularly useful for applications requiring the manipulation of two bands (e.g., C and L bands), simultaneously, wherein each band has its own corresponding in/out/add/drop ports. (*Id.*, 10:56-61.)

(aa) Claim 67

141. Claim 67 recites “wherein said beam-deflecting elements comprise an array of silicon micromachined mirrors.” Claim 67 is similar to apparatus claim 12 (other than being a method claim addressing an “array” of

mirrors) and is disclosed by each of Grounds 1 and 2 for the same reasons as for claim 12. (See § VI(g).)

VII. CONCLUSION

142. I reserve the right to offer opinions relevant to the invalidity of the '678 Patent claims at issue and/or offer testimony in support of the Declaration.

143. In signing this Declaration, I recognize that the Declaration will be filed as evidence in a contested case before the Patent Trial and Appeal Board of the United States Patent and Trademark Office. I also recognize that I may be subject to cross-examination in the case. If required, I will appear for cross-examination at an appropriate and convenient place and time.

144. I hereby declare that all statements made herein of my own knowledge are true and that all statements made on information and belief are believed to be true, and further that these statements were made with the knowledge that willful false statements and the like so made are punishable by fine or imprisonment, or both, under 28 U.S.C. § 1001.

Dated:

Feb. 13, 2015

Respectfully submitted,

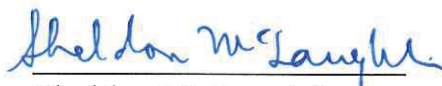

Sheldon McLaughlin