



US006567574B1

(12) **United States Patent**
Ma et al.

(10) **Patent No.:** **US 6,567,574 B1**
(45) **Date of Patent:** **May 20, 2003**

(54) **MODULAR THREE-DIMENSIONAL OPTICAL SWITCH**

(75) Inventors: **Jian Ma**, San Diego, CA (US); **Ezekiel John Joseph Kruglick**, San Diego, CA (US); **Daniel J. Reiley**, San Diego, CA (US); **Philippe Jean Marchand**, Poway, CA (US); **Steffen Gloeckner**, San Diego, CA (US)

(73) Assignee: **Omm, Inc.**, San Diego, CA (US)

(*) Notice: Subject to any disclaimer, the term of this patent is extended or adjusted under 35 U.S.C. 154(b) by 0 days.

(21) Appl. No.: **09/680,648**

(22) Filed: **Oct. 6, 2000**

(51) **Int. Cl.**⁷ **G02B 6/26**

(52) **U.S. Cl.** **385/16; 385/18; 385/19**

(58) **Field of Search** **385/16-20**

(56) **References Cited**

U.S. PATENT DOCUMENTS

3,430,057	A	2/1969	Genahr	
3,896,362	A	7/1975	Street	318/640
4,003,655	A	1/1977	Wasilko	356/4
4,208,094	A	6/1980	Tomlinson	
4,234,145	A	11/1980	Leiboff	244/3.16
4,256,927	A	3/1981	Treheux et al.	179/18
4,303,303	A	12/1981	Aoyama	350/96.2

(List continued on next page.)

FOREIGN PATENT DOCUMENTS

EP	0510629	10/1992		
EP	0880040	11/1998	G02B/6/26
EP	0902538	3/1999		
EP	0903607	3/1999	G02B/26/08
EP	0921702	6/1999		
EP	0902538	12/1999	H03K/17/968

(List continued on next page.)

OTHER PUBLICATIONS

Huja, Martin, "MEMS Structure—Micromirror Array," Proceedings of SPIE/vol. 4019, p. 556-566.

Boissier, Alain, "Space division optical switching system of medium capacities," Proceedings: Fiber Optic Broadband Networks, p. 65-70.

Laor, Herzal, "New Optical Switch Development," 7th European Conference on Optical Communication, Sep. 8-11, 1981 Bella Center.

Bright, Victor M., "Selected Papers on Optical MEMS," SPIE Milestone Series, vol. MS 153.

(List continued on next page.)

Primary Examiner—Ellen E. Kim

(74) *Attorney, Agent, or Firm*—Arien Ferrell; Fitch, Even, Tabin & Flannery

(57) **ABSTRACT**

A modular three-dimensional (3D) optical switch that is scalable and that provides monitor and control of MEMS mirror arrays. A first switch module includes an array of input channels. Light beams received from the input channels are directed toward a first wavelength selective mirror. The light beams are reflected off of the first wavelength selective mirror and onto a first array of moveable micromirrors. The moveable micromirrors are adjusted so that the light beams reflect therefrom and enter a second switch module where they impinge upon a second array of moveable micromirrors. The light beams reflect off of the second array of moveable micromirrors and impinge upon a second wavelength selective mirror. The light beams reflect off of the second wavelength selective mirror and into an array of output channels. The alignment or misalignment of a data path through the switch is detected by directing two monitor beams through the data path, one in the forward direction and one in the reverse direction. The position of each of the monitor beams is detected after its reflection from the second moveable micromirror that it hits. The position data is used to determine the angles of the moveable micromirrors in the data path.

71 Claims, 14 Drawing Sheets

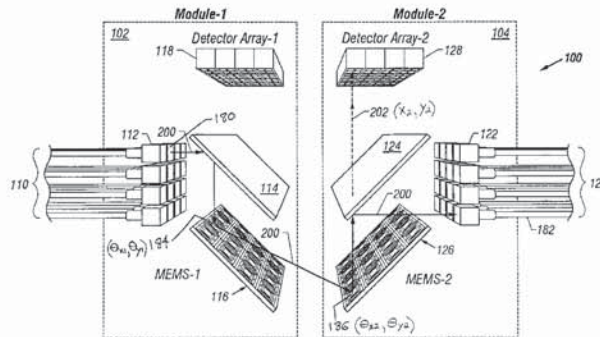

U.S. PATENT DOCUMENTS

4,317,611	A	3/1982	Peterson	
4,322,126	A	3/1982	Minowa et al.	350/96.2
4,365,863	A	12/1982	Broussaud	
4,431,258	A	2/1984	Fye	350/1.6
4,470,662	A	9/1984	Mumzhiu	350/96.15
4,534,615	A	8/1985	Iwasaki	350/6.1
4,566,935	A	1/1986	Hornbeck	
4,596,992	A	6/1986	Hornbeck	
4,626,066	A	12/1986	Levinson	
4,630,883	A	12/1986	Taylor	
4,662,746	A	5/1987	Hornbeck	
4,710,732	A	12/1987	Hornbeck	
4,796,263	A	1/1989	Rampolla	372/10
4,932,745	A	6/1990	Blonder	
4,956,619	A	9/1990	Hornbeck	
4,989,941	A	2/1991	Soref	
5,028,939	A	7/1991	Hornbeck	
5,037,173	A	8/1991	Sampsel	
5,096,279	A	3/1992	Hornbeck	
5,168,535	A	12/1992	Laor	385/16
5,172,262	A	12/1992	Hornbeck	
5,177,348	A	1/1993	Laor	
5,199,088	A	3/1993	Magel	
5,247,593	A	9/1993	Lin	
5,256,869	A	10/1993	Lin	
5,283,844	A	2/1994	Rice et al.	385/17
5,291,324	A	3/1994	Hinterlong	359/135
5,311,410	A	5/1994	Hsu	
5,317,659	A	5/1994	Lee	
5,410,371	A	4/1995	Lambert	
5,412,506	A	5/1995	Feldblum	
5,420,946	A	5/1995	Tsai	
5,436,986	A	7/1995	Tsai	
5,440,654	A	8/1995	Lambert, Jr.	
5,444,801	A	8/1995	Laughlin	
5,522,796	A	6/1996	Dorsey, III	604/118
5,524,153	A	6/1996	Laor	
5,621,829	A	4/1997	Ford	
5,627,669	A	5/1997	Orino	
5,646,928	A	7/1997	Wu	
5,647,033	A	7/1997	Laughlin	
5,661,591	A	8/1997	Lin	
5,748,812	A	* 5/1998	Buchin	385/18
5,774,604	A	6/1998	McDonald	
5,786,925	A	7/1998	Goossen et al.	359/245
5,808,780	A	9/1998	McDonald	359/290
5,841,917	A	11/1998	Jungerman et al.	385/17
5,867,297	A	2/1999	Kiang et al.	359/198
5,878,177	A	3/1999	Karasan	
5,903,687	A	5/1999	Young	
5,914,801	A	6/1999	Dhuler	
5,923,798	A	7/1999	Aksyuk et al.	385/19
5,933,269	A	8/1999	Robinson	359/280
5,943,454	A	8/1999	Aksyuk et al.	385/22
5,963,367	A	10/1999	Aksyuk	
5,969,465	A	10/1999	Neukermans et al.	310/333
5,994,159	A	11/1999	Aksyuk et al.	438/52
5,995,688	A	11/1999	Aksyuk et al.	385/14
6,002,818	A	12/1999	Fatchi	
6,031,946	A	2/2000	Bergmann	
6,031,947	A	2/2000	Laor	
6,044,705	A	4/2000	Neukermans	
6,087,747	A	7/2000	Dhuler et al.	310/90
6,097,858	A	8/2000	Laor	
6,097,860	A	8/2000	Laor	
6,101,299	A	* 8/2000	Laor	385/16
6,123,985	A	9/2000	Robinson	
6,134,031	A	10/2000	Nishi	
6,134,042	A	10/2000	Dhuler	
6,137,103	A	10/2000	Giles	
6,137,105	A	10/2000	Drobot	
6,137,926	A	10/2000	Maynard	
6,154,583	A	11/2000	Kuroyanagi	
6,154,585	A	11/2000	Copner	

6,157,026	A	12/2000	Redmer	
6,160,930	A	12/2000	Ferguson	
6,188,814	B1	2/2001	Bhalla	
6,195,190	B1	2/2001	Tachibe	
6,198,180	B1	3/2001	Garcia	
6,198,565	B1	3/2001	Iseki	
6,201,629	B1	3/2001	McClelland	
6,204,946	B1	3/2001	Aksyuk	
6,219,133	B1	4/2001	Kawase	
6,219,168	B1	4/2001	Wang	
6,219,472	B1	4/2001	Horino	
6,222,954	B1	4/2001	Riza	
6,320,993	B1	* 11/2001	Laor	385/16
6,327,398	B1	* 12/2001	Solgaard et al.	385/17

FOREIGN PATENT DOCUMENTS

EP	0962796	12/1999	
EP	1033601	9/2000	
EP	1039325	9/2000	
EP	1061389	12/2000	
EP	1067421	1/2001	
WO	WO 9304388	3/1993	
WO	WO 96/24870	8/1996	
WO	9624870	8/1996 G02B/6/26
WO	0880040	2/1999 G02B/6/26
WO	WO 99/63374	12/1999	
WO	WO 99/63531	12/1999	
WO	WO 99/66354	12/1999	
WO	9966354	12/1999	
WO	WO 99/67666	12/1999	
WO	9967666	12/1999 G02B/6/26
WO	WO 00/05832	2/2000	
WO	WO 00/20899	4/2000	
WO	0020899	4/2000	
WO	WO 00/25161	5/2000	
WO	WO 00/68719	11/2000	
WO	WO 00/73839	12/2000	
WO	WO 00/75711	12/2000	
WO	WO 00/77556	12/2000	
WO	WO 01/06543	1/2001	
WO	WO 01/07945	2/2001	
WO	WO 01/13151	2/2001	
WO	WO 01/24384	4/2001	
WO	WO 01/25848	4/2001	
WO	WO 01/27682	4/2001	

OTHER PUBLICATIONS

Fujita, Hiroyuki, "Application of micromachining technology to optical devices and systems," SPIE/vol. 2879, p. 2-11.

Dewa, Andrew S., "Development of a Silicon Two-Axis Micromirror for an Optical Cross-Connect," Solid-State Sensor and Actuator Workshop, p. 93-96.

Vdovin, Gleb, "Micromachined adaptive mirrors," Laboratory of Electronic Instrumentation, Delft University of Technology.

Hornbeck, Larry J., "Deformable-Mirror Spatial Light Modulators," SPIE Critical Reviews Series/vol. 1150, p. 86-102.

Fan, Li, "," Thesis, p. 1-134.

W. Piyawattanametha, "MEMS Technology for Optical Crosslinks for Micro/Nano Satellites," *International Conference on Integrated Nano/Microtechnology for Space Applications*, Houston, TX, Nov. 1-6, 1998, pp. 1-2.

L. Fan, "Two-Dimensional Optical Scanner with Large Angular Rotation Realized by Self-Assembled Micro-Elevator," *Proc. IEEE LEOS Summer Topical Meeting on Optical MEMS*, paper WB4, Monterey, CA, Aug. 20-22, 1998, pp. 1-8.

* cited by examiner

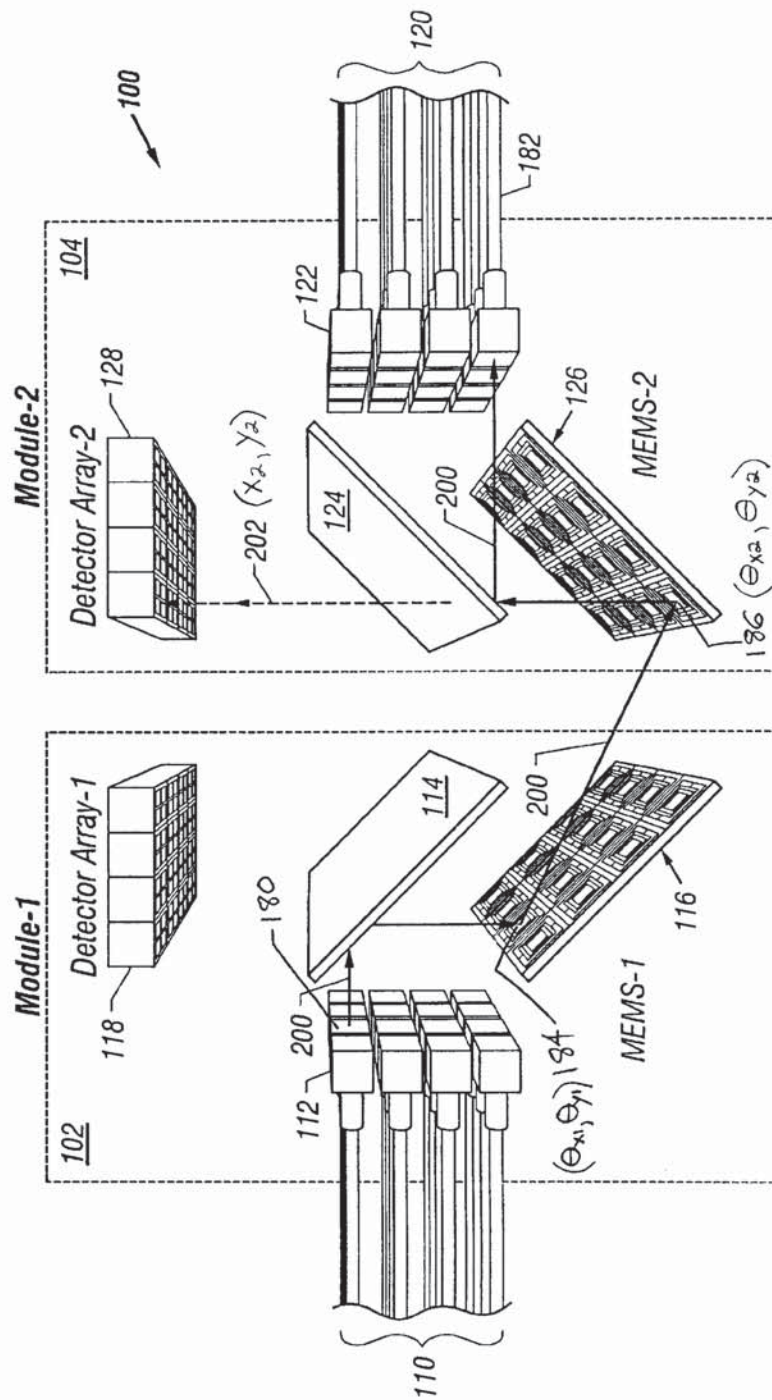

Fig. 1

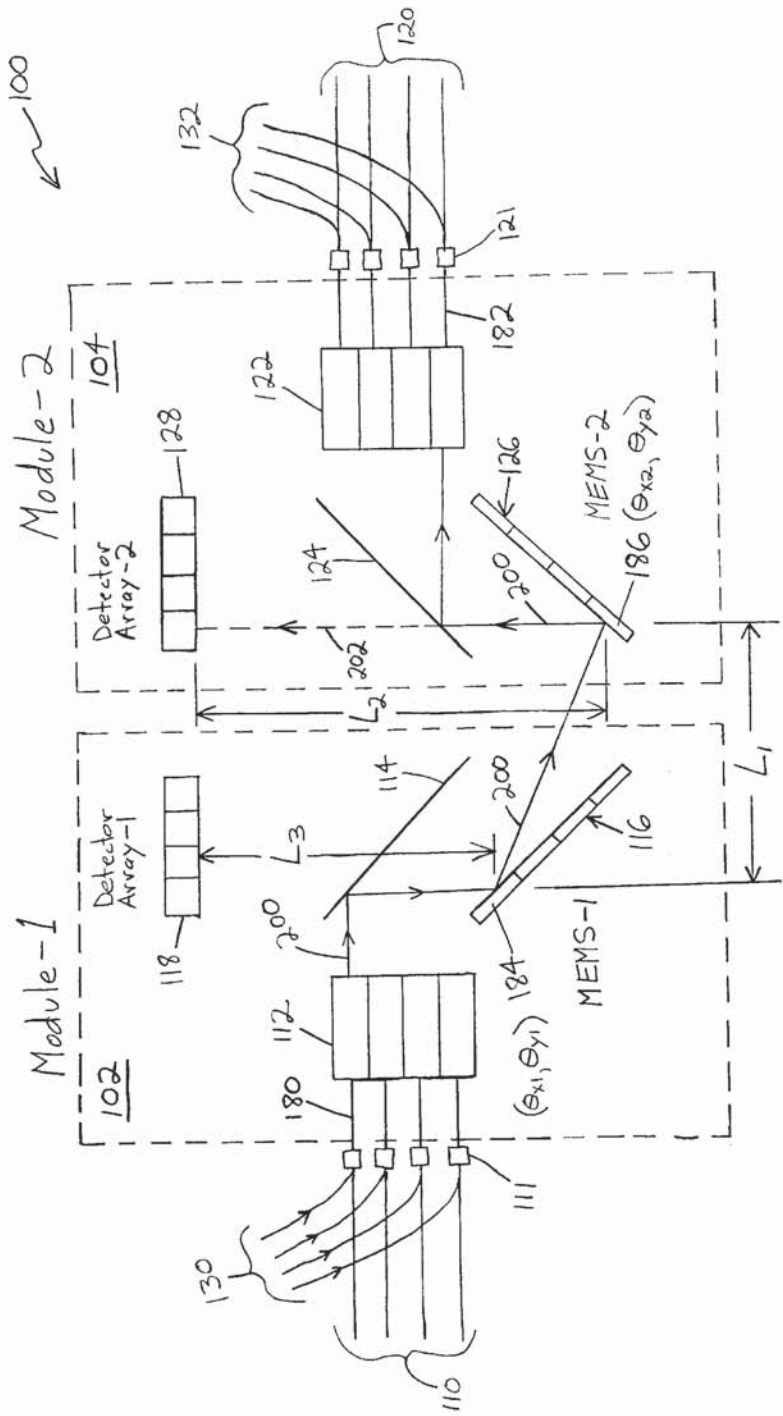

FIG. 2

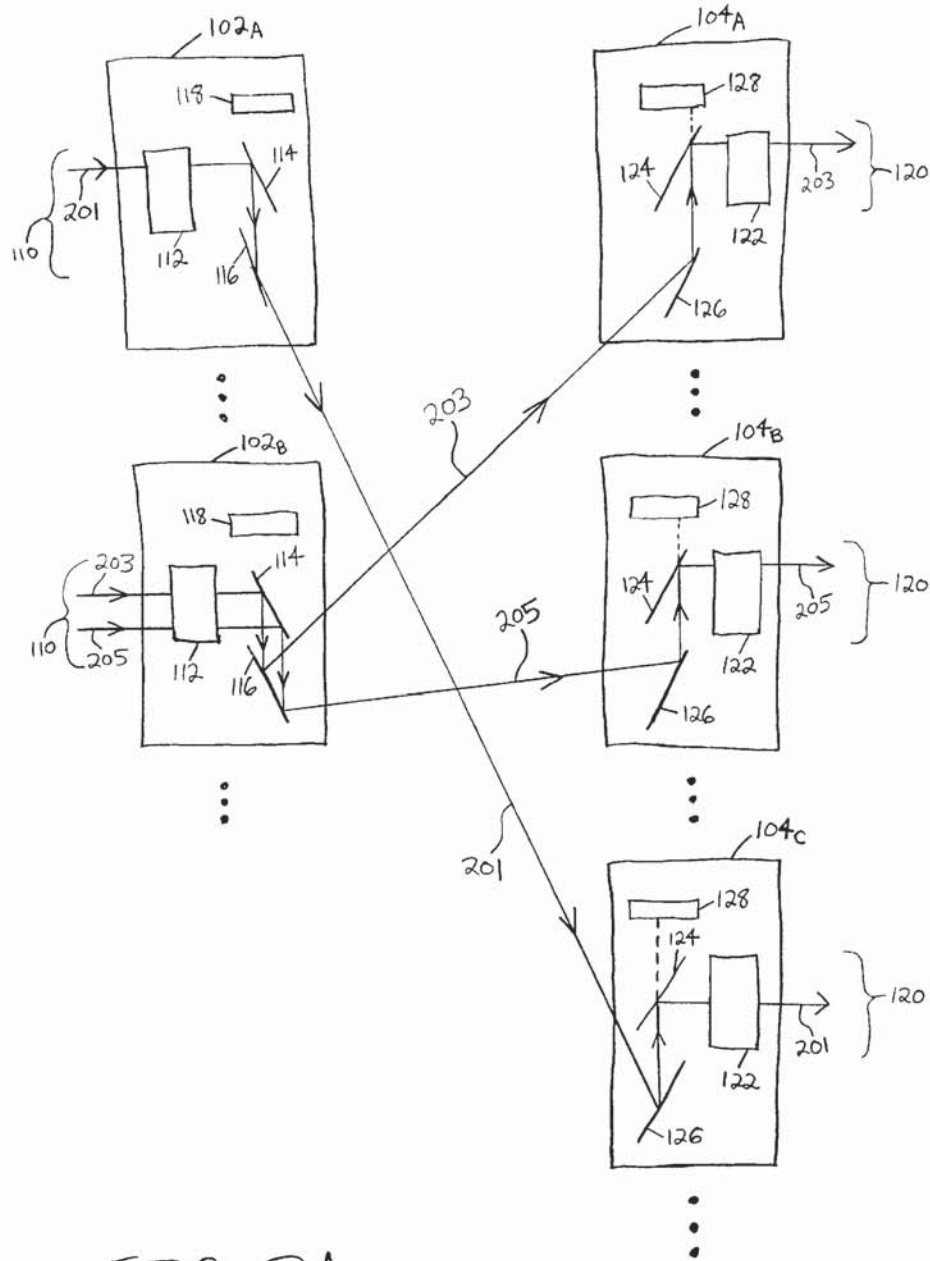

FIG. 3A

Explore Litigation Insights

Docket Alarm provides insights to develop a more informed litigation strategy and the peace of mind of knowing you're on top of things.

Real-Time Litigation Alerts



Keep your litigation team up-to-date with **real-time alerts** and advanced team management tools built for the enterprise, all while greatly reducing PACER spend.

Our comprehensive service means we can handle Federal, State, and Administrative courts across the country.

Advanced Docket Research



With over 230 million records, Docket Alarm's cloud-native docket research platform finds what other services can't. Coverage includes Federal, State, plus PTAB, TTAB, ITC and NLRB decisions, all in one place.

Identify arguments that have been successful in the past with full text, pinpoint searching. Link to case law cited within any court document via Fastcase.

Analytics At Your Fingertips



Learn what happened the last time a particular judge, opposing counsel or company faced cases similar to yours.

Advanced out-of-the-box PTAB and TTAB analytics are always at your fingertips.

API

Docket Alarm offers a powerful API (application programming interface) to developers that want to integrate case filings into their apps.

LAW FIRMS

Build custom dashboards for your attorneys and clients with live data direct from the court.

Automate many repetitive legal tasks like conflict checks, document management, and marketing.

FINANCIAL INSTITUTIONS

Litigation and bankruptcy checks for companies and debtors.

E-DISCOVERY AND LEGAL VENDORS

Sync your system to PACER to automate legal marketing.