

UNITED STATES PATENT AND TRADEMARK OFFICE

---

BEFORE THE PATENT TRIAL AND APPEAL BOARD

---

LUMENTUM HOLDINGS, INC., LUMENTUM, INC.,  
LUMENTUM OPERATIONS, LLC, CORIANT OPERATIONS, INC.,  
CORIANT (USA) INC., CIENA CORPORATION, CISCO SYSTEMS,  
INC., and FUJITSU NETWORK COMMUNICATIONS, INC.,  
Petitioner,

v.

CAPELLA PHOTONICS, INC.,  
Patent Owner.

---

Case IPR2015-00731<sup>1</sup>  
Patent RE42,368

---

Before JOSIAH C. COCKS, KALYAN K. DESHPANDE, and  
JAMES A. TARTAL, *Administrative Patent Judges*.

TARTAL, *Administrative Patent Judge*.

FINAL WRITTEN DECISION

35 U.S.C. § 318(a) and 37 C.F.R. § 42.73

---

<sup>1</sup> IPR2015-01969 was joined with IPR2015-00731 on March 10, 2016, by Order in IPR2015-01969, Paper 11 (IPR2015-00731, Paper 42).

## I. INTRODUCTION

Petitioner, Lumentum Holdings, Inc., Lumentum Inc., Lumentum Operations, LLC, Coriant Operations, Inc., Coriant (USA) Inc., Ciena Corporation, Cisco Systems, Inc., and Fujitsu Network Communications, Inc., filed petitions requesting an *inter partes* review of claims 1–6, 9–13, and 15–22 of U.S. Patent No. RE42,368 (“the ’368 patent”). Paper 1 (“Petition” or “Pet.”); *see also* IPR2015-01969, Paper 6.

Claims 1–6, 9–13, and 15–22 of the ’368 patent were previously held to be unpatentable in *Cisco Systems, Inc., Ciena Corporation, Coriant Operations, Inc., Coriant (USA) Inc., and Fujitsu Network Communications, Inc. v. Capella Photonics, Inc.*, IPR2014-01166, (PTAB Jan. 28, 2016) (Paper 44) (the ’1166 case). Claims 1–6, 9–12, and 15–22 of the ’368 patent also were previously held to be unpatentable in *Fujitsu Network Communications, Inc., Coriant Operations, Inc., Coriant (USA) Inc., and Ciena Corporation v. Capella Photonics, Inc.*, IPR2015-00726, (PTAB Sep. 28, 2016) (Paper 38) (the ’726 case). The grounds of unpatentability asserted by Petitioner in this case rely on combinations of prior art, evidence, and arguments not asserted in either the ’1166 case or the ’726 case. Likewise, Patent Owner, Capella Photonics, Inc., advances arguments and evidence in response in this case that were not asserted by Patent Owner in either the ’1166 case or the ’726 case.

Based on the information provided in the Petition, and in consideration of the Preliminary Response (Paper 7) of Patent Owner, we instituted a trial pursuant to 35 U.S.C. § 314(a) of: (1) claims 1–6, 9–11, 13,

and 15–22 as obvious over Bouevitch,<sup>2</sup> Sparks<sup>3</sup>, and Lin<sup>4</sup> under 35 U.S.C. § 103(a); and, (2) claim 12 as obvious over Bouevitch, Sparks, Lin, and Dueck<sup>5</sup> under 35 U.S.C. § 103(a). Paper 8 (“Institution Decision”); *see also* IPR2015-01969, Paper 11.

After institution of trial, Patent Owner filed a Response (Paper 17, “Response” or “PO Resp.”) and Petitioner filed a Reply (Paper 37, “Pet. Reply”). The Petition is supported by the Declaration of Sheldon McLaughlin (Ex. 1028). The Response is supported by the Declaration of Dr. Alexander V. Sergienko (Ex. 2022).

A transcript of the Oral Hearing conducted on May 24, 2016, is entered as Paper 50 (“Tr.”).

We issue this Final Written Decision pursuant to 35 U.S.C. § 318(a) and 37 C.F.R. § 42.73. For the reasons that follow, Petitioner has shown by a preponderance of the evidence that claims 1–6, 9–13, and 15–22 of the ’368 patent are unpatentable.

## II. BACKGROUND

### A. *The ’368 patent (Ex. 1001)*

The ’368 patent, titled “Reconfigurable Optical Add-Drop Multiplexers with Servo Control and Dynamic Spectral Power Management Capabilities,” reissued May 17, 2011, from U.S. Patent No. 6,879,750

---

<sup>2</sup> U.S. Patent No. 6,498,872 B2, issued December 24, 2002 (Ex. 1003, “Bouevitch”)

<sup>3</sup> U.S. Patent No. 6,625,340 B1, issued September 23, 2003 (Ex. 1004, “Sparks”).

<sup>4</sup> U.S. Patent No. 5,661,591, issued August 26, 1997 (Ex. 1010, “Lin”)

<sup>5</sup> U.S. Patent No. 6,011,884, issued January 4, 2000 (Ex. 1021, “Dueck”)

(“the ’750 patent”). Ex. 1001. The ’750 patent issued April 12, 2005, from application number 10/745,364, filed December 22, 2003.

According to the ’368 patent, “fiber-optic communications networks commonly employ wavelength division multiplexing (WDM), for it allows multiple information (or data) channels to be simultaneously transmitted on a single optical fiber by using different wavelengths and thereby significantly enhances the information bandwidth of the fiber.” *Id.* at 1:37–42. An optical add-drop multiplexer (OADM) is used both to remove wavelengths selectively from a multiplicity of wavelengths on an optical fiber (taking away one or more data channels from the traffic stream on the fiber), and to add wavelengths back onto the fiber (inserting new data channels in the same stream of traffic). *Id.* at 1:45–51.

The ’368 patent describes a “wavelength-separating-routing (WSR) apparatus that uses a diffraction grating to separate a multi-wavelength optical signal by wavelength into multiple spectral channels, which are then focused onto an array of corresponding channel micromirrors.” *Id.* at Abstract. “The channel micromirrors are individually controllable and continuously pivotable to reflect the spectral channels into selected output ports.” *Id.* According to Petitioner, the small, tilting mirrors are sometimes called Micro ElectroMechanical Systems or “MEMS.” Pet. 8.

The WSR described in the ’368 patent may be used to construct dynamically reconfigurable OADMs for WDM optical networking applications. Ex. 1001, Abstract.

Figure 1A of the '368 patent is reproduced below.

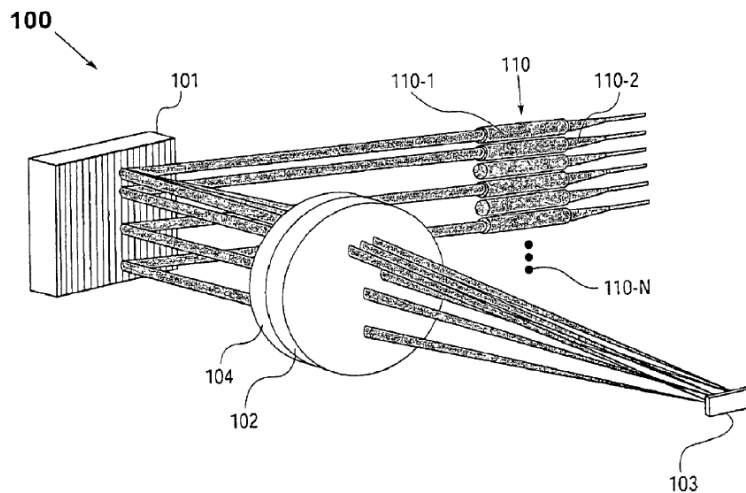

Fig. 1A

Figure 1A depicts wavelength-separating-routing (WSR) apparatus 100, in accordance with the '368 patent. WSR apparatus 100 is comprised of an array of fiber collimators 110 (multiple input/output ports, including input port 110-1 and output ports 110-2 through 110-N), diffraction grating 101 (a wavelength separator), quarter wave plate 104, focusing lens 102 (a beam-focuser), and array of channel micromirrors 103. Ex. 1001, 6:57–63, 7:55–56.

A multi-wavelength optical signal emerges from input port 110-1 and is separated into multiple spectral channels by diffraction grating 101, which are then focused by focusing lens 102 into a spatial array of distinct spectral spots (not shown). *Id.* at 6:64–7:2. Channel micromirrors 103 are positioned such that each channel micromirror receives one of the spectral channels.

# Explore Litigation Insights

Docket Alarm provides insights to develop a more informed litigation strategy and the peace of mind of knowing you're on top of things.

## Real-Time Litigation Alerts



Keep your litigation team up-to-date with **real-time alerts** and advanced team management tools built for the enterprise, all while greatly reducing PACER spend.

Our comprehensive service means we can handle Federal, State, and Administrative courts across the country.

## Advanced Docket Research



With over 230 million records, Docket Alarm's cloud-native docket research platform finds what other services can't. Coverage includes Federal, State, plus PTAB, TTAB, ITC and NLRB decisions, all in one place.

Identify arguments that have been successful in the past with full text, pinpoint searching. Link to case law cited within any court document via Fastcase.

## Analytics At Your Fingertips



Learn what happened the last time a particular judge, opposing counsel or company faced cases similar to yours.

Advanced out-of-the-box PTAB and TTAB analytics are always at your fingertips.

## API

Docket Alarm offers a powerful API (application programming interface) to developers that want to integrate case filings into their apps.

## LAW FIRMS

Build custom dashboards for your attorneys and clients with live data direct from the court.

Automate many repetitive legal tasks like conflict checks, document management, and marketing.

## FINANCIAL INSTITUTIONS

Litigation and bankruptcy checks for companies and debtors.

## E-DISCOVERY AND LEGAL VENDORS

Sync your system to PACER to automate legal marketing.