

Reconfigurable Multichannel Optical Add–Drop Multiplexers Incorporating Eight-Port Optical Circulators and Fiber Bragg Gratings

An Vu Tran, *Student Member, IEEE*, Wen De Zhong, *Member, IEEE*, Rodney S. Tucker, *Fellow, IEEE*, and Kai Song, *Member, IEEE*

Abstract—We propose and demonstrate two new strictly nonblocking reconfigurable multichannel optical add–drop multiplexers (RM-OADMs) using optical circulators and fiber Bragg gratings. By effectively using eight-port optical circulators, the new structures significantly reduce component count and insertion loss, and achieve good crosstalk performance. One of the new RM-OADMs potentially achieves the lowest insertion loss among existing RM-OADMs.

Index Terms—Circulator, crosstalk, fiber grating, multichannel, nonblocking, optical add–drop multiplexer, reconfigurable, wavelength-division multiplexing.

I. INTRODUCTION

IN WAVELENGTH-DIVISION-MULTIPLEXING (WDM) networks, reconfigurable multichannel optical add–drop multiplexers (RM-OADMs) are required to flexibly configure and reconfigure optical paths. Critical issues in the design of RM-OADMs are insertion loss, crosstalk, and component count. Many types of RM-OADMs, based on different optical devices, have been proposed and demonstrated [1]–[5]. RM-OADMs can also be constructed by cascading multiple conventional single-channel OADMs [6]. Among these, the optical circulator (OC)-fiber Bragg grating (FBG)-based RM-OADMs [3]–[6] are very promising because of their low crosstalk, and temperature and polarization insensitivity. In addition, OC-FBG-based RM-OADMs do not cause bandwidth-narrowing when WDM signals pass through many OADM nodes. However, these OC-FBG-based RM-OADMs still suffer from high component count and high insertion loss due to the use of many circulators [3], [4], [6], and a mux–demux pair [5]. Moreover, the use of the mux–demux pair in the RM-OADM structure proposed in [5] prevents the flexible add–drop of channels in WDM systems.

In this letter, we present two new strictly nonblocking RM-OADMs incorporating OCs and FBGs [7]. The devices have separate add and drop ports for each channel and can accommodate any arbitrary wavelength add–drop schemes.

Manuscript received May 8, 2001; revised July 11, 2001.

A. V. Tran and R. S. Tucker are with the Australian Photonics Cooperative Research Centre, Photonics Research Laboratory, Department of Electrical and Electronic Engineering, The University of Melbourne, Vic. 3010, Australia (e-mail: a.tran@ee.mu.oz.au).

W. D. Zhong is with the School of Electrical and Electronic Engineering, Nanyang Technological University, 639 798 Singapore.

K. Song is with Sycamore Networks, Chelmsford, MA 01824 USA.

Publisher Item Identifier S 1041-1135/01/001001-06

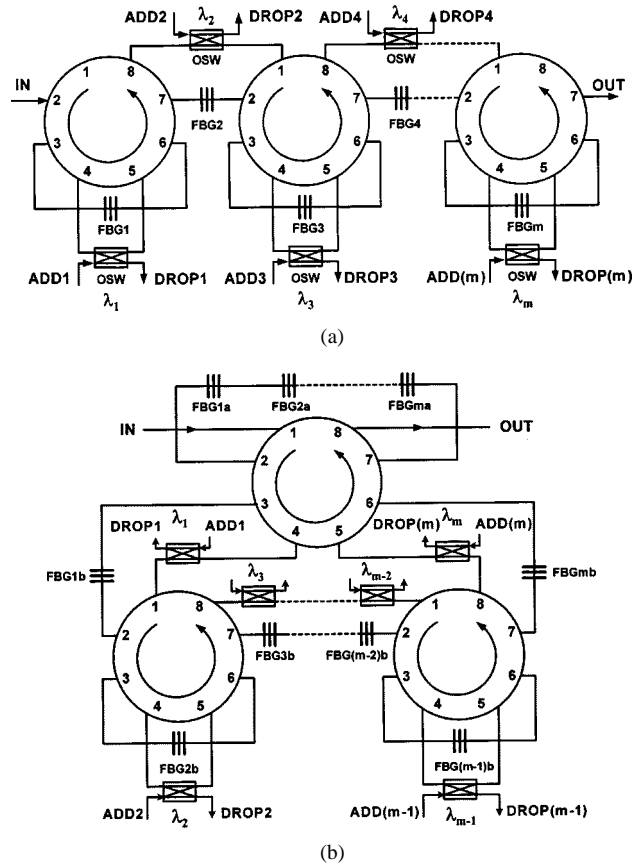

Fig. 1. New RM-OADM structures. (a) Structure I. (b) Structure II.

The devices significantly reduce the required number of OCs and insertion loss by effectively using eight-port OCs. One of the new RM-OADMs potentially achieves the lowest insertion loss for through channels among existing RM-OADMs [1]–[6].

II. NEW RM-OADM STRUCTURES

A. Structure I

The first RM-OADM structure is shown schematically in Fig. 1(a). The device consists of k eight-port OCs, m FBGs and $m \times 2 \times 2$ optical switches (OSWs) to accommodate m add–drop channels. The Bragg wavelength λ_i ($1 \leq i \leq m$) of the FBG_i is designed to match the WDM channel λ_i . An OSW is connected between ports four and five of each OC. If the OSW is in the bar state, the channel corresponding to the FBG connected between ports three and six of each OC

goes from port four to port five and through the device together with other through channels. If the OSW is in the cross state, the channel is dropped through port four and the OSW, and another channel at the same wavelength can be added through the OSW to port five, similarly to that described in [6]. An OSW is also connected between port eight of each OC and port one of the next OC. If the OSW is in the bar state, the channel corresponding to the FBG connected between port seven of each OC and port two of the next OC is not dropped and goes through the device. If the OSW is in the cross state, the channel is dropped through port eight and the OSW, and the add channel at the same wavelength can enter the device via port one of the next OC. Port one of the first OC and port eight of the last OC are left for use as additional add-drop ports, if required. The RM-OADM Structure I is strictly nonblocking. Only the channels to be drop/added are affected during the switching operation.

The number of eight-port OCs required is $k = \lceil (m+1)/2 \rceil$ ($\lceil x \rceil$ represents the smallest integer greater than or equal to x). In other words, an increase of one additional eight-port OC can provide two additional add-drop channels. In comparison, if we use four-port OCs [4] or six-port OCs [6] to build a RM-OADM with m add-drop channels, the number of OCs required is $(m+1)$ or m , respectively, which is about twice that for eight-port OCs. Note that the cost for a commercial eight-port OC is not much higher than that for six-port and four-port OCs and their sizes are the same. Therefore, the new RM-OADM is more compact and cost-effective.

If L_{OC} is the insertion loss between two adjacent ports of an OC, and L_{FBG} is the out-of-band transmission insertion loss of a FBG, then the insertion loss for through channels is $L_I = (m+1)L_{OC} + mL_{FBG}$. Assuming $L_{OC} = 1$ dB and $L_{FBG} = 0.1$ dB, for a RM-OADM with five add-drop channels, the insertion loss is 6.5 dB, which is smaller than most of other existing OC-FBG-based RM-OADMs [3], [4], [6].

B. Structure II

Although Structure I has reduced insertion loss for through channels, the insertion loss is still proportional to the number of OCs used. The second structure aims to substantially reduce the insertion loss for through channels. It is shown schematically in Fig. 1(b). Structure II consists of the same number of eight-port OCs and 2×2 OSWs, and twice the number of FBGs to accommodate the same number of add-drop channels as Structure I. FBG_{ia} and FBG_{ib} have the same Bragg wavelength λ_i corresponding to the WDM channel λ_i . A number of FBGs corresponding to the channels to be reconfigured are connected between ports two and seven of the first OC. An OSW is connected between port four of the first OC and port one of the second OC. If the OSW is in the bar state, the channel at the corresponding Bragg wavelength of the FBG connected between port three of the first OC and port two of the second OC is not dropped and goes through the device and exits the OUT port. If the OSW is in the cross state, the channel is dropped through port four of the first OC and the OSW, and the add channel at the same wavelength can enter port one of the second OC via the OSW.

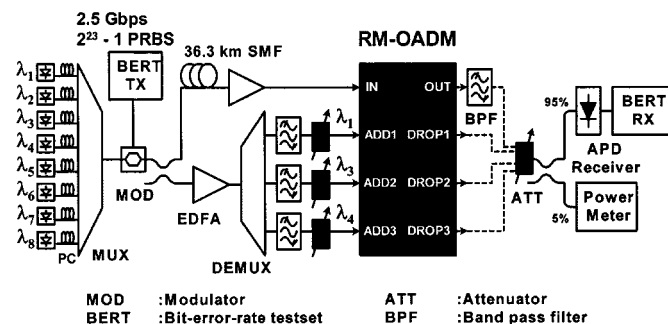

Fig. 2. WDM test setup using new RM-OADM structures.

corresponding to the FBG connected between port six of the first OC and port seven of the last OC. The arrangement of FBGs and OSWs, and the add-drop operations from the second OC to the last OC, are the same as that of Structure I. The RM-OADM Structure II is also strictly nonblocking.

The function of the first OC is to separate the through channels from the add-drop channels, which makes the insertion loss independent of the number of OCs used. This is very important in networks with multiple OADM nodes and few or no in-line optical amplifiers. The insertion loss for through channels is $L_I = 2L_{OC} + mL_{FBG}$, which is independent of the number of OCs used. Assuming $L_{OC} = 1$ dB and $L_{FBG} = 0.1$ dB as before, for a RM-OADM with five add-drop channels, the insertion loss is 2.5 dB, which is the smallest among all existing RM-OADMs [1]–[6].

For both RM-OADM structures, the in-band crosstalk between the add-drop channels depends on the reflectivity of the FBG and the leakage through the OSW, whereas the out-of-band crosstalk from the adjacent to the drop channels depends on the FBG reflection of adjacent channels [6].

III. EXPERIMENTAL SETUP AND RESULTS

The performance of the new RM-OADMs is experimentally investigated in the eight-channel WDM test setup, shown in Fig. 2. The RM-OADMs consist of two eight-port OCs, and three FBGs of wavelengths 1549.32, 1550.92, and 1551.72 nm corresponding to channels one, three, and four of the input WDM signal, respectively. For Structure II, three pairs of gratings at the same Bragg wavelengths are used. The average interport insertion loss and isolation of each OC are 1.2 and >45 dB, respectively. The 3-dB bandwidth, adjacent channel reflection and reflectivity of the FBGs are 0.3 nm, -30 dB, and 99.99%, respectively, except for the second grating at 1550.92 used in Structure II, which only has 99.7% reflectivity. We operate the RM-OADMs in such a way that all channels corresponding to the FBGs are add/dropped. No OSWs are used in the experiment. When OSWs are employed in the RM-OADM structures, the insertion loss for the reconfigured channels is increased and depending on the OSW leakage, the in-band crosstalk between the add and drop channels may be higher. Eight laser sources from 1549.32 to 1554.92 nm with 0.8-nm spacing are multiplexed by an 8×8 arrayed-waveguide grating (AWG) and externally modulated with a $2^{23} - 1$

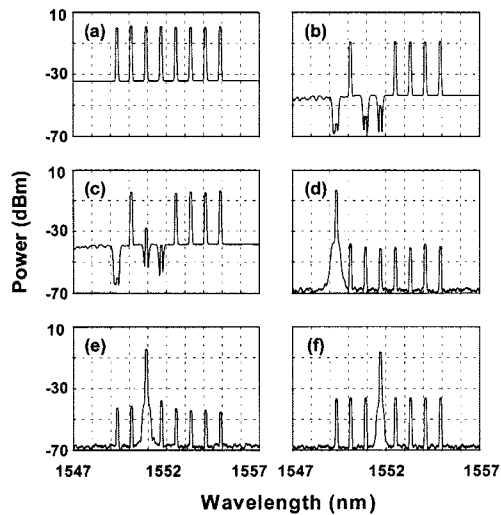

Fig. 3. Optical spectra at different RM-OADM ports. (a) IN port of both Structure I and II. (b) OUT port of Structure I without any add channels present. (c) OUT port of Structure II without any add channels present. (d) DROP1 port of Structure I with all add channels present. (e) DROP2 port of Structure I with all add channels present. (f) DROP3 port of Structure I with all add channels present.

sources are split into two paths. Path one goes through 36.3 km of standard single-mode fiber (SMF) for bit decorrelation, and amplified by an erbium-doped fiber amplifier (EDFA) before entering the IN port of the RM-OADM. Path two is amplified by an EDFA, and demultiplexed by another 8×8 AWG to represent three add channels. Optical attenuators are used after the AWG to equalize the add and through channels powers at the OUT port of the RM-OADM. The bit-error rates (BERs) and spectra of the three drop, and one through channels are measured at the DROP1, DROP2, DROP3, and OUT ports of the RM-OADM, respectively.

The measured optical spectra at different RM-OADM ports are shown in Fig. 3. The spectrum at the OUT port of Structure I without any add channels [see Fig. 3(b)] shows small in-band crosstalk of less than -40 dB from the three drop channels one, three, and four. The insertion loss for through channels for Structure I is 8.5 dB. Fig. 3(c) shows the spectrum obtained at the OUT port of Structure II. The insertion loss for through channel for Structure II is only 3.5 dB. Due to the poor reflectivity of the particular FBG used in the experiment for Structure II, an in-band crosstalk of -25 dB is observed at 1550.92 nm. The spectra at the DROP1, DROP2, and DROP3 ports of Structure I with all add channels present [see Fig. 3(d)–(f), respectively] show very small out-of-band crosstalk of less than -30 dB from the through channels and adjacent add channels. The spectra at different drop ports of Structure II are similar to those of Structure I (not shown).

Fig. 4(a) and (b) show the BERs measured at the DROP1 and DROP3 ports of Structure I with and without the add channels present, along with a back-to-back measurement for the drop channel one (1549.32 nm) and drop channel four (1551.72 nm), respectively. The result shows no power penalty between the back-to-back with and without add channels

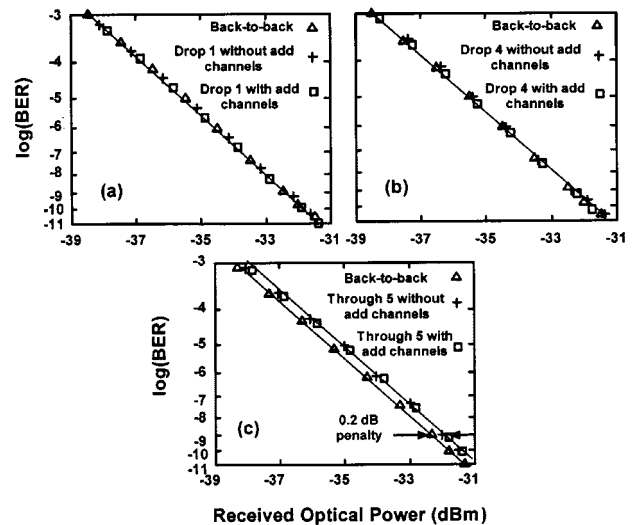

Fig. 4. Bit-error rate curves for Structure I. (a) Drop channel one. (b) Drop channel four. (c) Through channel five.

the through channel five (1552.52 nm) with and without the three add channels, together with a back-to-back measurement in Fig. 4(c). The result shows negligible penalty of 0.2 dB between the back-to-back and the with and without add channels cases. This is due to imperfect filtering before the receiver. The BERs obtained for Structure II are similar to those of Structure I (not shown), which also indicates negligible in-band and out-of-band crosstalk from the add and through to the drop channels.

IV. CONCLUSION

We have proposed and demonstrated two new strictly non-blocking RM-OADMs using OCs and FBGs. By effectively using eight-port OCs, the new structures significantly reduce the component count and insertion loss and achieve good crosstalk performance. Structure II potentially achieves the lowest insertion loss for through channels among existing RM-OADMs.

REFERENCES

- [1] W. D. Zhong, S. Dods, J. P. R. Lacey, and R. S. Tucker, "Reconfigurable multichannel add-drop multiplexer with improved performance," *Electron. Lett.*, vol. 32, pp. 1477–1478, 1996.
- [2] A. Jourdan, F. Bakhti, L. Berthelon, F. Bruyere, M. W. Chbat, D. Chiaroni, C. Drion, G. J. Eilenberger, M. Garnot, F. Masetti, P. A. Perrier, and M. Renaud, "Key building blocks for high-capacity WDM photonic transport networks," *IEEE J. Select. Areas Commun.*, vol. 16, pp. 1286–1297, Sept. 1998.
- [3] Y. Park, H. Park, and C. J. Chae, "A study on $1:N$ protected WDM systems and the architecture of an ADM for its implementation," *IEEE Photon. Technol. Lett.*, vol. 10, pp. 1510–1512, Oct. 1998.
- [4] S. K. Liaw, K. P. Ho, and S. Chi, "Multichannel add/drop and cross-connect using fiber bragg gratings and optical switches," *Electron. Lett.*, vol. 34, pp. 1601–1602, 1998.
- [5] H. Okayama, Y. Ozeki, T. Kamijoh, C. Q. Xu, and I. Asabayashi, "Dynamic wavelength selective add/drop node comprising fiber gratings and optical switches," *Electron. Lett.*, vol. 33, pp. 403–404, 1997.
- [6] A. V. Tran, W. D. Zhong, R. S. Tucker, and R. Lauder, "Optical add-drop multiplexers with low crosstalk," *IEEE Photon. Technol. Lett.*, vol. 13, pp. 582–584, June 2001.
- [7] W. D. Zhong, R. S. Tucker, K. Song, and A. V. Tran, "A multichannel