



(19) **United States**

(12) **Patent Application Publication** (10) **Pub. No.: US 2002/0097956 A1**  
**Kikuchi et al.** (43) **Pub. Date: Jul. 25, 2002**

(54) **FIBER COLLIMATOR ARRAY**

**Publication Classification**

(76) Inventors: **Juro Kikuchi**, Kakegawa-City (JP);  
**Yasuyuki Mizushima**, Kakegawa-City  
(JP); **Hiroki Takahashi**, Fukuroi City  
(JP); **Yoshiaki Takeuchi**, Shizuoka-shi  
(JP)

(51) **Int. Cl.<sup>7</sup>** ..... **G02B 6/32**  
(52) **U.S. Cl.** ..... **385/33; 385/34**

(57) **ABSTRACT**

An optical fiber collimator array includes an optical fiber array block and a microlens array substrate. The optical fiber array block includes an angled surface and is configured to receive and retain a plurality of individual optical fibers, which carry optical signals. The microlens array substrate includes a plurality of microlenses integrated along a microlens surface and a sloped surface opposite the microlens surface. The microlens surface is coupled to the angled surface such that the optical signals from the individual optical fibers are each collimated by a different one of the integrated microlenses.

Correspondence Address:  
**CORNING INCORPORATED**  
**SP-TI-3-1**  
**CORNING, NY 14831**

(21) Appl. No.: **09/767,255**

(22) Filed: **Jan. 22, 2001**

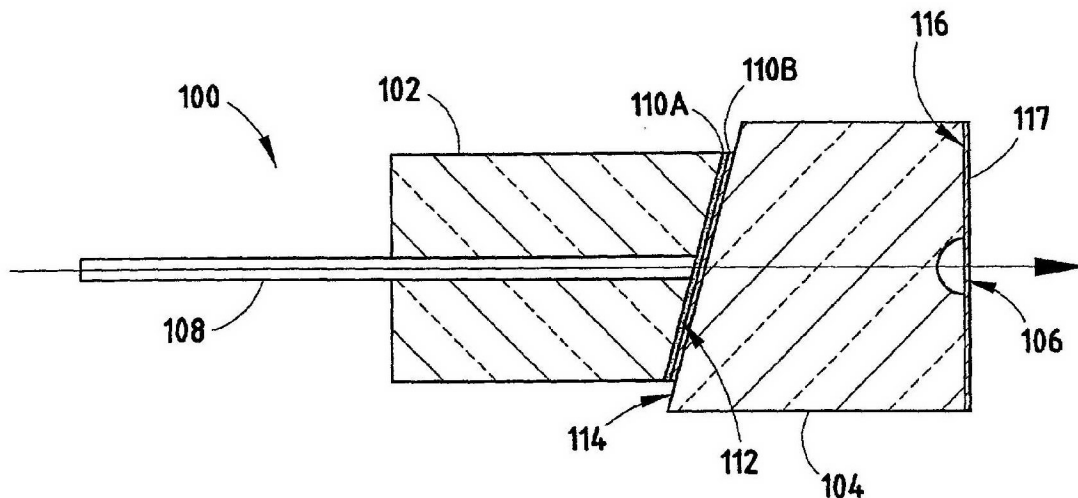

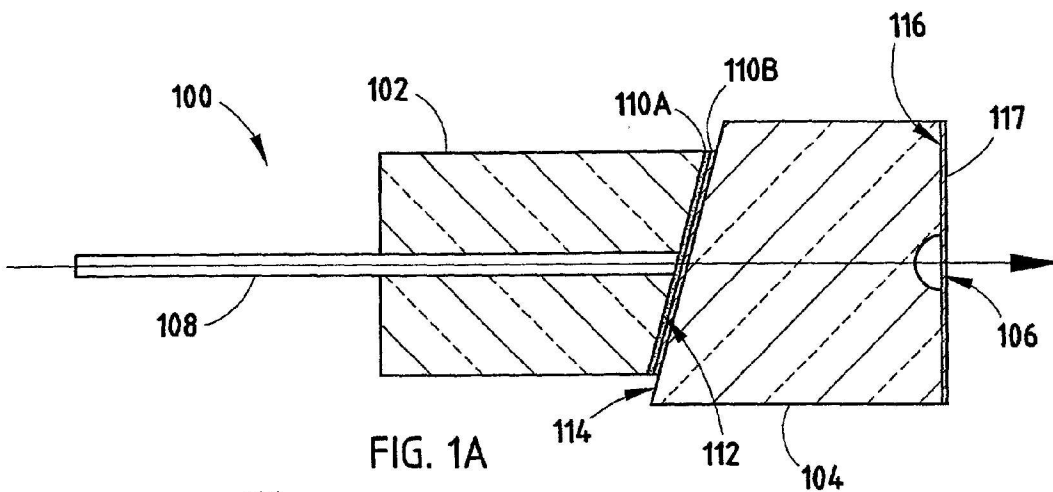

FIG. 1A

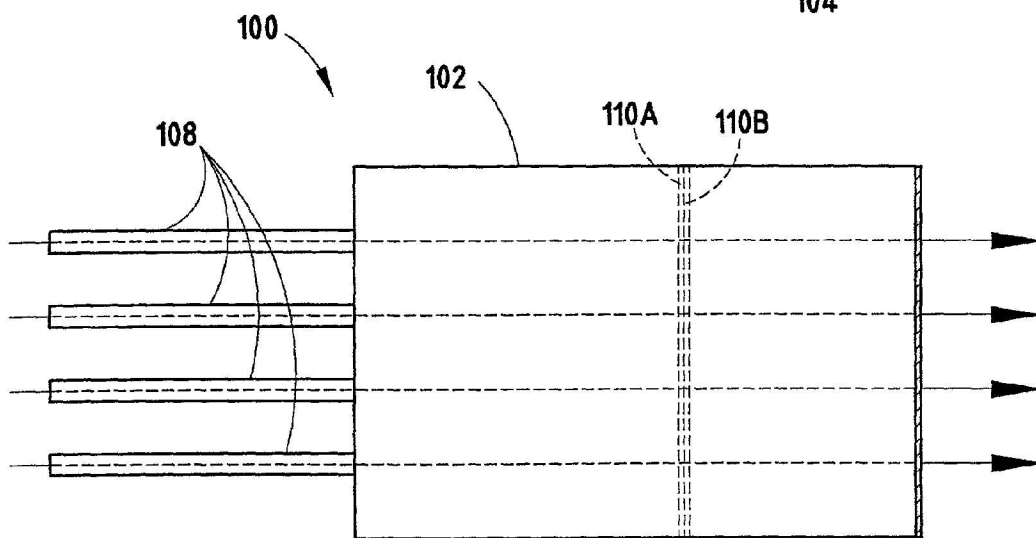

FIG. 1B

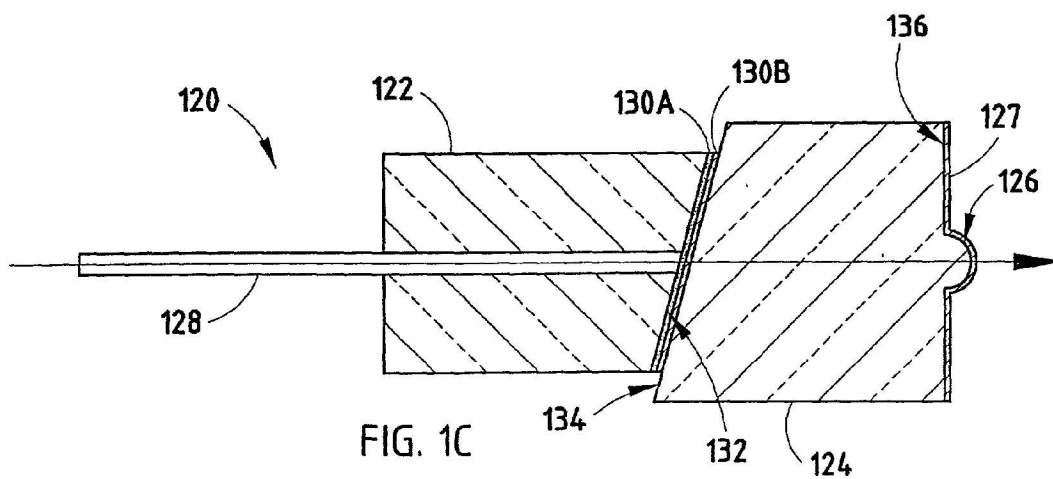
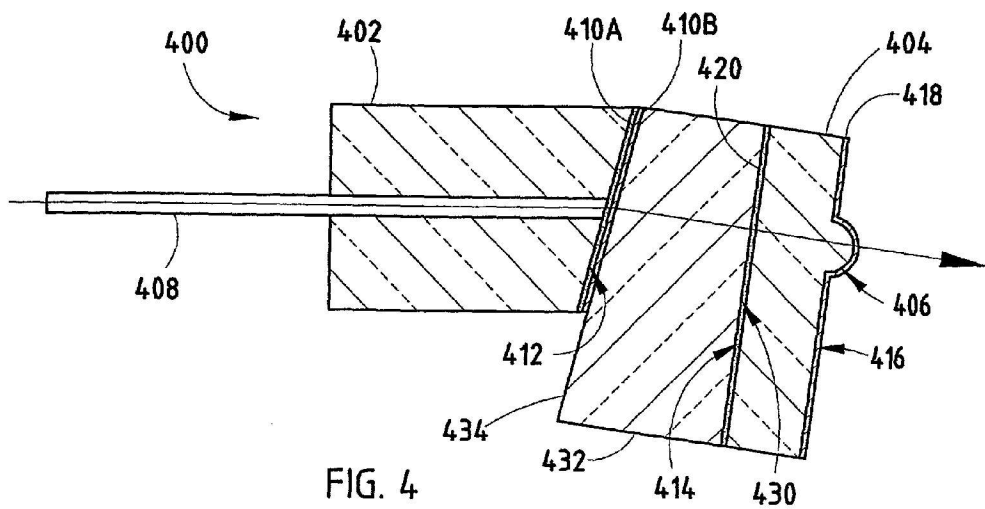
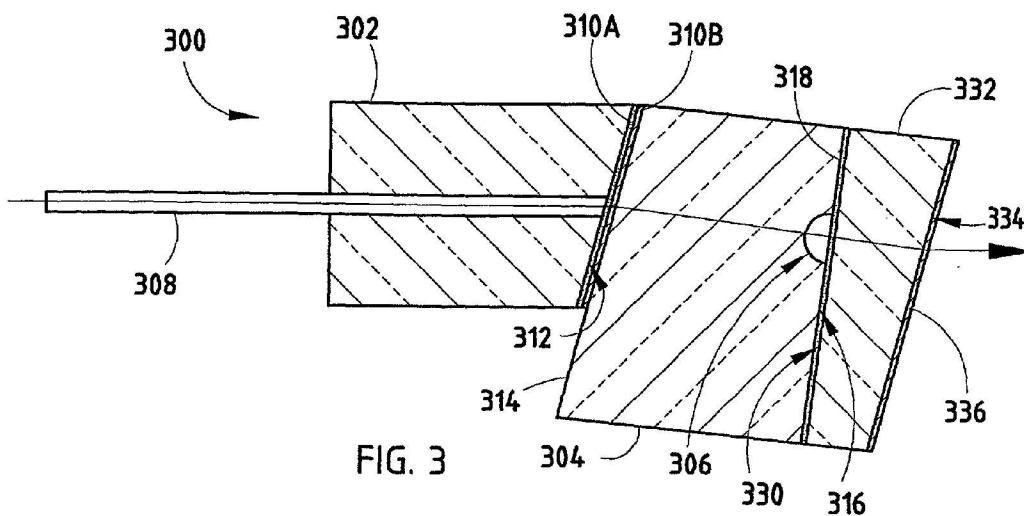
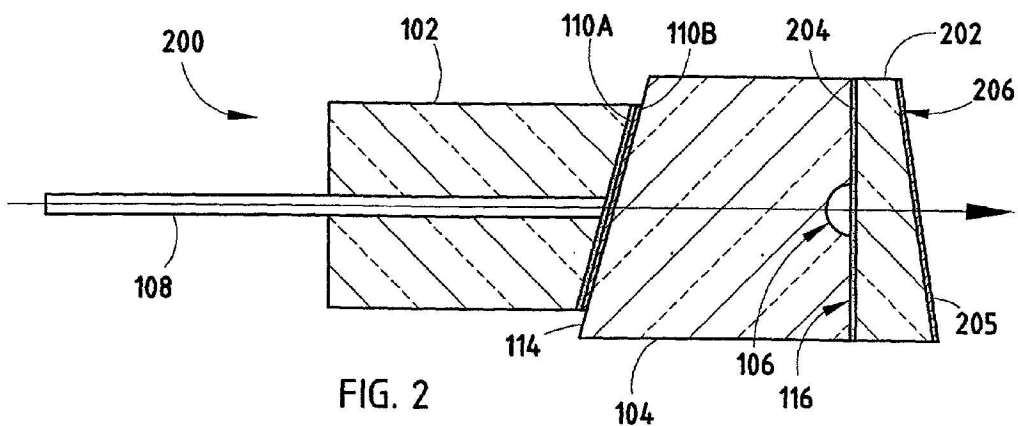
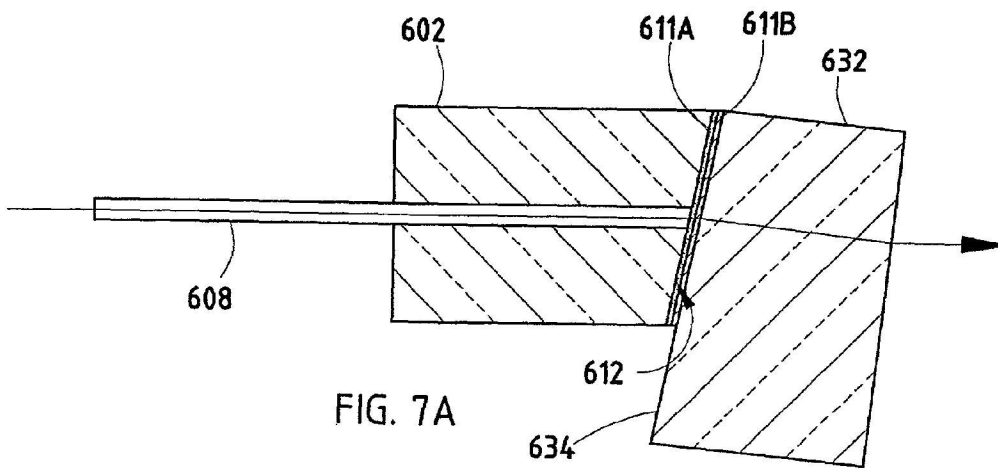
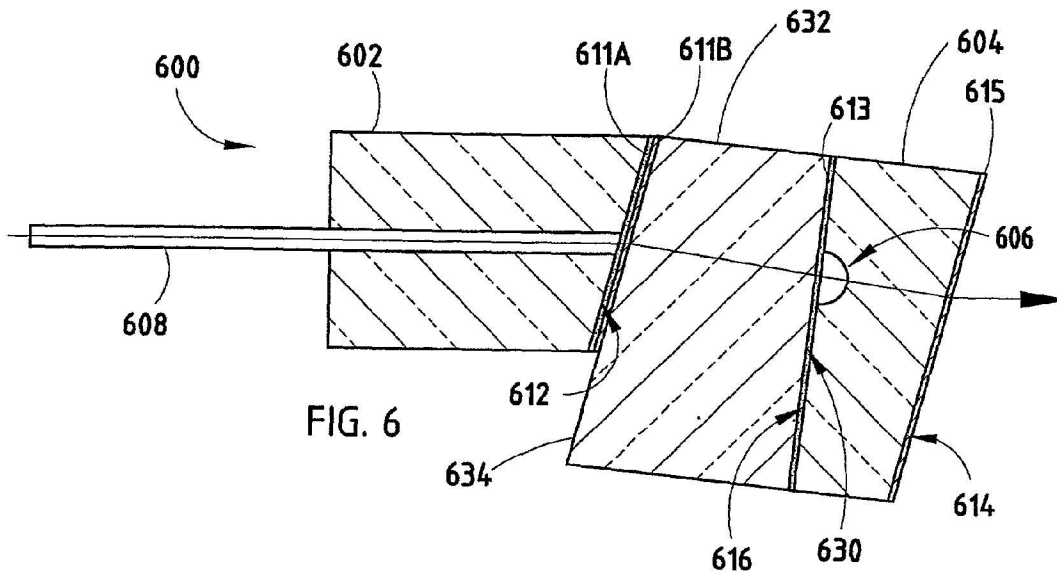
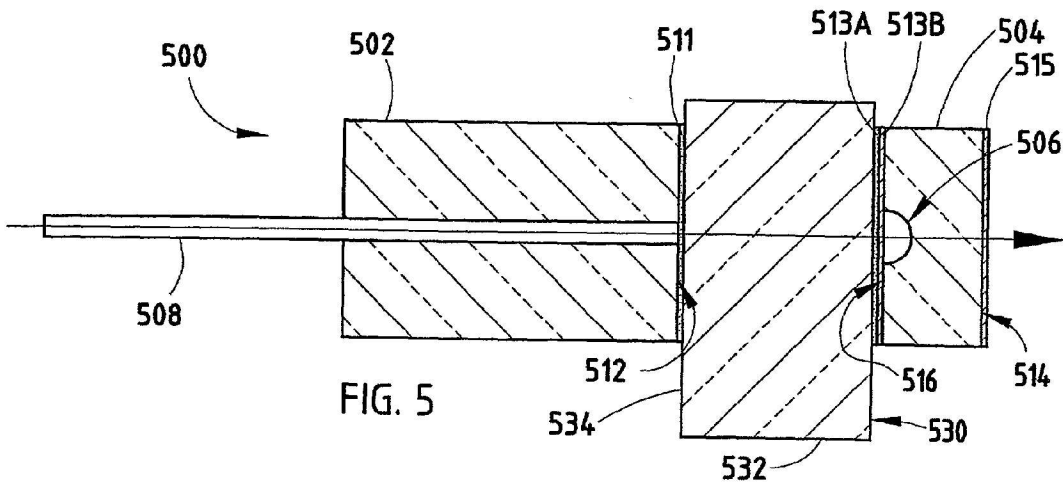
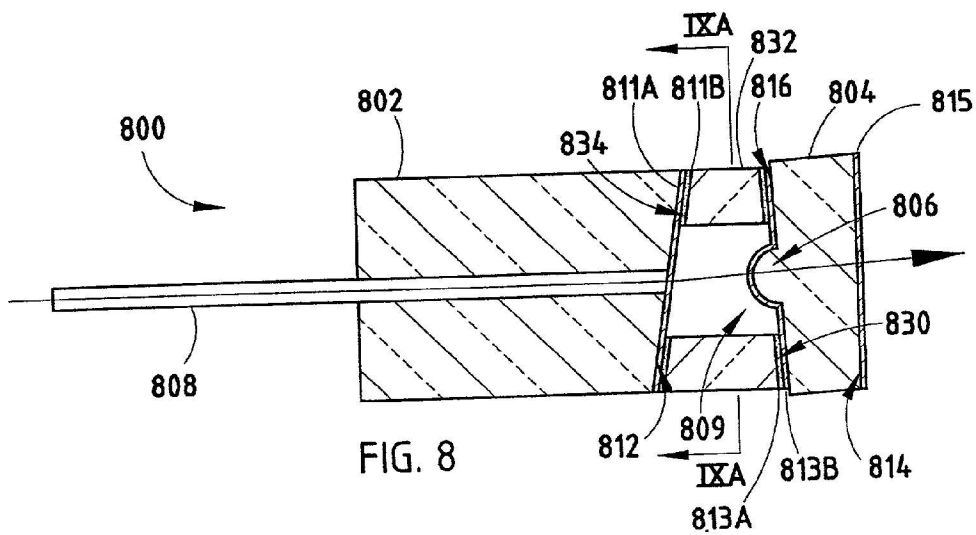
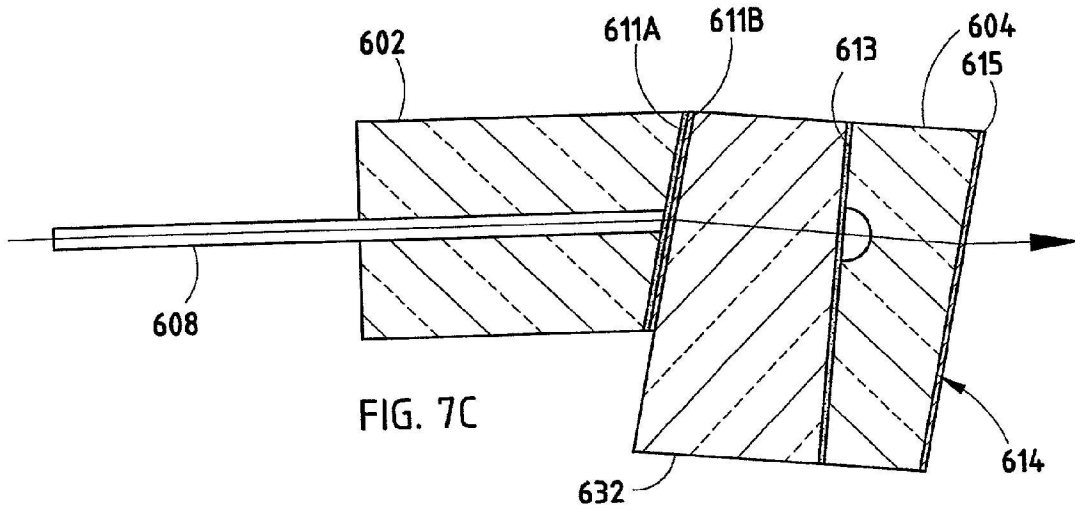
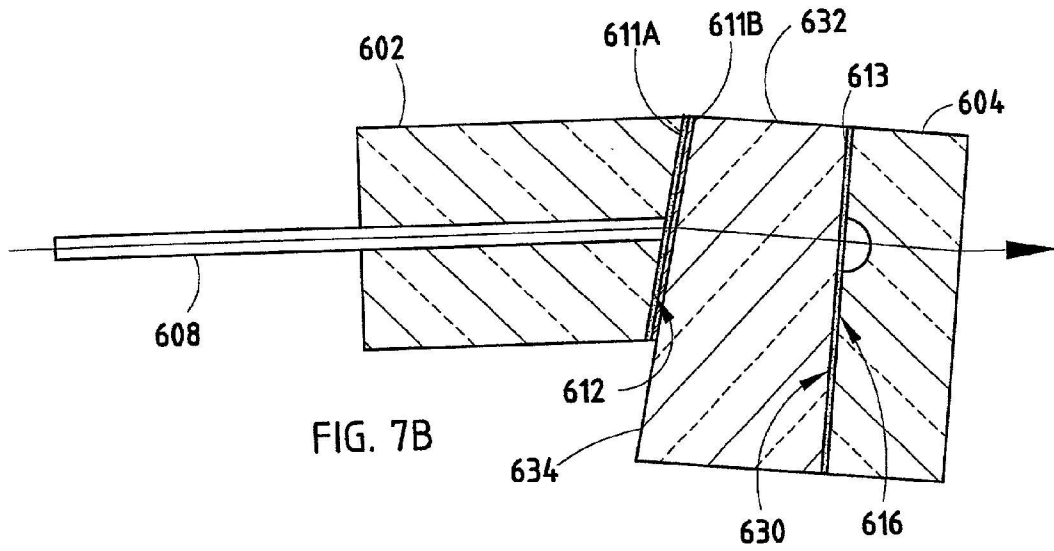
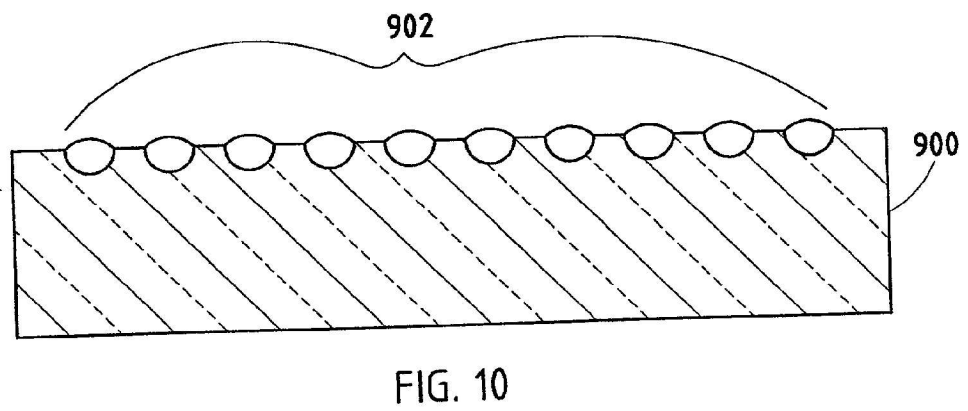
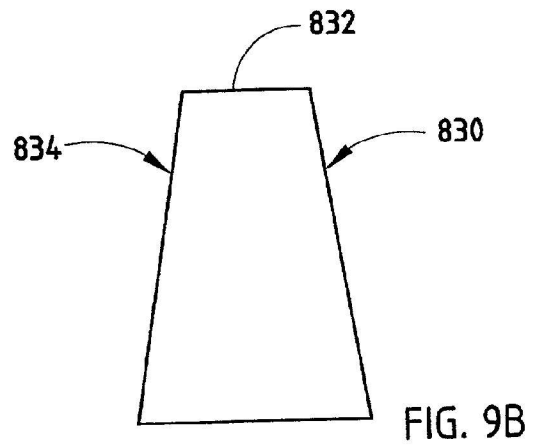
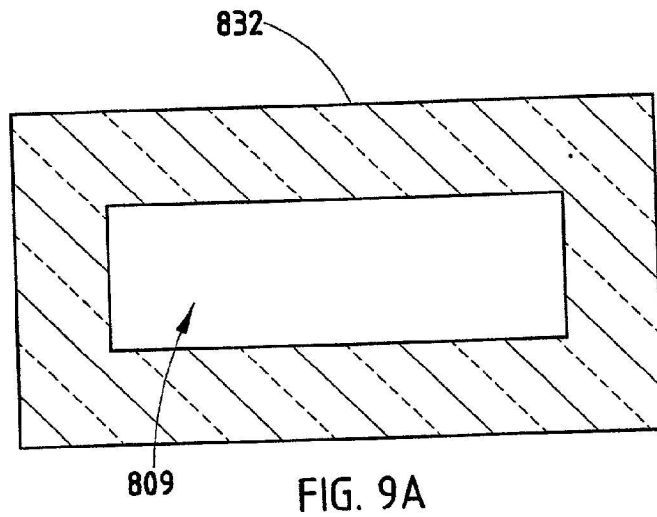

FIG. 1C









## FIBER COLLIMATOR ARRAY

### BACKGROUND OF THE INVENTION

[0001] 1. Field of the Invention

[0002] The present invention is directed to a fiber collimator array and more specifically to a fiber collimator array for use in an optical transmission system and/or an optical sensor system.

[0003] 2. Technical Background

[0004] Collimation is a process by which divergent beams of radiation or particles (e.g., light rays) are converted into parallel beams. Laser diode (LD) collimating lenses are commonly used in laser beam printers, bar code scanners and sensors. In addition, fiber collimators are widely used in a variety of optical applications (e.g., optical filters). Due to the recent increase in demand for fiber collimators, to be used with wave division multiplexed (WDM) systems, reducing the fiber collimator cost has become increasingly important.

[0005] However, commercially available fiber collimator arrays have typically implemented separate lenses, which has increased the cost of the array. For example, one commercially available collimator array has utilized a V-groove array substrate with individually aligned gradient-index (GRIN) microlenses and fibers in each V-groove. These GRIN microlenses have generally been produced by an ion-exchange process and normally provide high coupling efficiency and have been utilized as collimators for laser beam printers, bar code scanners, optical isolators, circulators and digital versatile disc (DVD) players, as well as miniature objective lenses for medical/industrial endoscopes.

[0006] Planar microlens arrays (PMLAs) are two-dimensional GRIN-type lens arrays that integrate ion-exchange technology and photolithography. By diffusing ions through a photolithographic mask into a glass substrate, numerous microscopic lenses can be formed in various sizes and patterns. Commercially available PMLAs are available with swelled lens surfaces, which tend to increase coupling efficiencies in transceiver applications, or with flat surfaces, which typically simplify collimation with fiber arrays. PMLAs have been used in liquid crystal projectors, three dimensional data processing and two dimensional laser diode (LD) coupling to fibers. Other manufactures, such as Rochester Photonics Corp., have produced aspheric collimating microlenses that are intended to replace GRIN-type microlenses in collimating applications.

[0007] However, the effectiveness of GRIN-type PMLAs and collimating arrays incorporating aspheric collimating microlenses are highly dependent on the configuration of the fiber collimator array. As such, it is important to configure the fiber collimator array to reduce insertion loss and internal reflections.

### SUMMARY OF THE INVENTION

[0008] An embodiment of the present invention is directed to an optical fiber collimator array that includes an optical fiber array block and a microlens array substrate. The optical fiber array block includes an angled surface and is configured to receive and retain a plurality of individual optical

fibers, which carry optical signals. The microlens array substrate includes a plurality of microlenses integrated along a microlens surface and a sloped surface opposite the microlens surface. The microlens surface is coupled to the angled surface such that the optical signals from the individual optical fibers are each collimated by a different one of the integrated microlenses.

[0009] According to another embodiment of the present invention, an optical fiber collimator array includes an optical fiber array block, a microlens array substrate and an index-matched spacer. The optical fiber array block is configured to receive and retain a plurality of individual optical fibers, which carry optical signals. The microlens array substrate includes a plurality of microlenses integrated along a microlens surface and the index-matched spacer couples the optical fiber array block to the microlens array substrate.

[0010] Additional features and advantages of the invention will be set forth in the detailed description which follows and will be apparent to those skilled in the art from the description or recognized by practicing the invention as described in the description which follows together with the claims and appended drawings.

[0011] It is to be understood that the foregoing description is exemplary of the invention only and is intended to provide an overview for the understanding of the nature and character of the invention as it is defined by the claims. The accompanying drawings are included to provide a further understanding of the invention and are incorporated and constitute part of this specification. The drawings illustrate various features and embodiments of the invention which, together with their description, serve to explain the principals and operation of the invention.

### BRIEF DESCRIPTION OF THE DRAWINGS

[0012] FIG. 1A is a cross-sectional view of an optical fiber collimator array, according to an embodiment of the present invention;

[0013] FIG. 1B is a top plan view of the array of FIG. 1A;

[0014] FIG. 1C is a cross-sectional view of an optical fiber collimator array, according to another embodiment of the present invention;

[0015] FIG. 2 is a cross-sectional view of the collimator array of FIG. 1A that additionally includes an index-matched angled spacer;

[0016] FIG. 3 is a cross-sectional view of another embodiment of an optical fiber collimator array of the present invention;

[0017] FIG. 4 is a cross-sectional view of yet another embodiment of an optical fiber collimator array of the present invention;

[0018] FIG. 5 is a cross-sectional view of still another embodiment of an optical fiber collimator array of the present invention;

[0019] FIG. 6 is a cross-sectional view of a different embodiment of an optical fiber collimator array of the present invention;

[0020] FIGS. 7A-7C are cross-sectional views of the optical fiber collimator array of FIG. 6 during assembly;

[0021] FIG. 8 is a cross-sectional view of an optical fiber collimator array that utilizes a spacer with a hole;

[0022] FIGS. 9A-9B are cross-sectional, taken through sectional line IXA, and end elevational views, respectively, of the spacer of FIG. 8; and

[0023] FIG. 10 is a cross-sectional view of a microlens array substrate with a non-flat lens surface.

#### DETAILED DESCRIPTION OF THE PREFERRED EMBODIMENT(S)

[0024] The present invention is directed to an optical fiber collimator array that includes a microlens array substrate and an optical fiber array block that are configured to reduce insertion loss and to reduce internal reflections. Each microlens is preferably a graded-index (GRIN) lens, an aspheric lens or a Fresnel lens. A GRIN lens has a refractive index that decreases with distance from its optical axis (i.e., center). This causes light rays to travel in sinusoidal paths, with the length of one complete cycle being known as the pitch of the lens. Commercially available fiber array blocks typically have a pitch of either two-hundred fifty microns or one-hundred twenty-seven microns. The pitch of the fiber block limits the microlens diameter, which may limit the coupling efficiency of the lens since the modefield diameter of the optical power (of the optical signal) in the microlens plane is limited by the microlens diameter.

[0025] To reduce coupling loss to less than 0.01 dB, the modefield diameter should typically be less than half the effective microlens diameter. As such, when a GRIN lens with a pitch of two-hundred fifty microns is used, the modefield diameter should be less than one-hundred ten microns since the effective lens diameter is typically less than ninety percent of the physical lens diameter. While a larger collimated beam diameter is preferable in order to get higher coupling efficiency, at typical working distances over a few millimeters, in practical use, the modefield diameter limits the diameter of the collimated optical beam. As such, the dimensions of the fiber collimator array, including the optical fiber array block and the microlens array substrate, are limited. Preferably, the modefield diameter of an optical signal on a microlens plane should be set close to one-hundred ten microns.

[0026] Turning to FIGS. 1A-1B, a cross-sectional and top plan view, respectively, of an optical fiber collimator array 100, according to an embodiment of the present invention, are depicted. The array 100 retains a plurality of optical fibers 108 within an optical fiber array block 102, which includes a plurality of channels for receiving the fibers 108, which are preferably retained within the block 102 with an adhesive. A planar graded-index (GRIN) microlens array substrate 104 includes a plurality of GRIN microlenses 106, which are spaced such that each microlens 106 receives an optical signal from one of the optical fibers 108. The fiber array block 102 includes an angled surface 112, opposite the end of the fiber block 102 in which the fibers 108 enter the fiber block 102. The microlens array substrate 104 includes a sloped surface 114 opposite the microlenses 106 (i.e., a microlens surface 116). The angled surface 112, of the fiber array block 102, and the sloped surface 114, of the microlens array substrate 104, are designed to reduce reflection at the boundary between the block 102 and the substrate 104. Preferably, the microlens array substrate 104 is made of a

glass (e.g., PYREX®) and one end of the fibers 108 are fixed flush with and have substantially the same angle as the angled surface 112.

[0027] The block 102 and the substrate 104 are preferably joined to each other through the use of a commercially available index-matched optical adhesive 110A, preferably using an active alignment tool. Suitable UV-cured index-matched optical adhesives are commercially available from NTT Advanced Technology Corporation (e.g., product number 9389 is suitable for a refractive index of 1.448). If desired, a conventional anti-reflection (AR) coating or coatings 110B may also be added to the interface between the block 102 and the substrate 104. The angles (i.e., the angled surface 112 and the sloped surface 114) are preferably eight degrees from perpendicular to the optical axes of the fibers 108, which, in theory, should provide at least a 60 dB attenuation of any reflected signal. Reflections can also be further reduced at the microlens surface 116 by applying an AR coating (or a multi-layer AR coating) 117 to the surface 116. However, utilizing an AR coating 117 with the microlens array substrate 104, of FIG. 1A, has been shown to only reduce reflections to about one-tenth of one percent of the transmitted signal (i.e., about 30 dB). While a return loss of 30 dB is acceptable in many applications, such a return loss is generally not acceptable in some practical applications, such as fiber amplifier modules.

[0028] FIG. 1C illustrates a cross-sectional view of an optical fiber collimator array 120, according to another embodiment of the present invention, that retains a plurality of optical fibers 128 within an optical fiber array block 122. The fiber collimator array 120 can typically achieve a return loss greater than 60 dB when AR coatings are utilized. An aspheric microlens array substrate 124 includes a plurality of aspheric microlenses 126, which are spaced such that each microlens 126 receives an optical signal from one of the optical fibers 128. The fiber array block 122 includes an angled surface 132, opposite the end of the fiber block 122 in which the fibers 128 enter the block 122. The microlens array substrate 124 includes a sloped surface 134 opposite the microlenses 126 (i.e., a microlens surface 136). The angled surface 132 of the fiber array block 122 and the sloped surface 134 of the microlens array substrate 124 are designed to reduce reflection at the boundary between the block 122 and the substrate 124. Preferably, the microlens array substrate 124 is also made of a glass (e.g., PYREX®).

[0029] The block 122 and the substrate 124 are preferably attached to each other through the use of an index-matched optical adhesive 130A, preferably using an active alignment tool, and may included an AR coating (or coatings) 130B at the interface. Similar to the collimator array 100 of FIG. 1A, the angles of the block 122 and substrate 124 are preferably eight degrees from perpendicular to the optical axes of the fibers 128. Reflections can also be further reduced by applying an anti-reflection (AR) coating 127 to the microlens surface 136.

[0030] The reflections of the array 100 can be further reduced through the implementation of an index-matched angled spacer. As shown in FIG. 2, an optical fiber collimator array 200 includes an index-matched angled spacer 202, which reduces reflections at the microlens surface 116 of the GRIN microlens array substrate 104. Preferably, the angled spacer 202 is attached to the microlens surface 116,



of the array substrate **104**, with an index-matched optical adhesive **204**, after active alignment of the microlens array **104** with the fiber array block **102**. The refractive index of the spacer **202** is preferably selected to be substantially the same as that of the microlens **106**. When another device, such as an optical filter, is not directly connected to the spacer **202**, a slanted surface **206** of the spacer **202**, opposite that attached to the microlens array substrate **104**, is also preferably coated with an AR coating **205** to further reduce reflection. Typically, a slant of less than about one degree is enough for the spacer **202** to adequately attenuate any reflections (i.e., at least a 60 dB loss).

[0031] In the fiber collimator arrays **100**, **120** and **200** of FIGS. 1A-1C and **2**, respectively, the optical beam axis generally slightly slants at the boundary of the fiber array block and the microlens array substrate when the refractive index of the materials (i.e., the fiber core and substrate) differ from each other. As such, the coupling efficiency of an optical system, that includes such a collimator array, is slightly degraded. This is because the modefield center of optical power in the microlens plane slightly shifts from the center of the microlens. This slight shift adversely affects the coupling efficiency, since the whole optical beam modefield is very close to the effective microlens area.

[0032] Moving to FIG. 3, a cross-sectional view of an optical fiber collimator array **300**, according to yet another embodiment of the present invention, is depicted. In general, the fiber collimator array **300** provides a higher coupling efficiency as compared to the fiber collimator arrays of FIGS. 1A-1C and **2**. As shown in FIG. 3, an optical fiber array block **302** retains a plurality of optical fibers **308**. An angled surface **312** of the fiber array block **302** is coupled (preferably, with an index-matched optical adhesive **310A**) to a sloped surface **314** of a GRIN microlens array substrate **304**. If desired, an AR coating **310B** may also be provided at the interface between the block **302** and the substrate **304**. The sloped surface **314** of the microlens array substrate **304** is preferably formed at an angle that is different from the angled surface **312** of the fiber array block **302**.

[0033] The center angle of the sloped surface **314** of the microlens array substrate **304** is, preferably, adjusted to be a somewhat different value from  $8\pm 0.5$  degrees, depending on the difference of the refractive index of the core of fibers **308** and the microlens array substrate **304**. If the refractive index of the microlens array substrate **304** is 1.66, for example, an appropriate center angle is about 83 degrees. The microlens array substrate **304** is adjusted in relation to the block **302** such that the optical beam axis coincides with the optical axis (i.e., center) of each of the microlenses **306**. In this configuration, the reflection from the microlens surface **316** can be reduced by using an index-matched optical adhesive **318** and by attaching an index-matched angled spacer **332** that includes an AR coating **336** on its slanted surface **334**. A back surface **330** of the spacer **332** does not require an AR coating, since the index of the spacer **332** preferably matches that of the microlens **306**. A similar configuration can also be utilized in conjunction with an aspheric microlens array substrate, such as that of FIG. 1C.

[0034] A preferred material for the optical fiber array blocks of FIGS. 1A-1C, **2** and **3** is PYREX® or silicon glass, which is selected to match the coefficient of thermal expansion (CTE) of the microlens array substrate material. That is,

if the microlens array substrate is made of silica glass, the same material (silica glass) would be a preferred choice for the material of the fiber array block.

[0035] FIG. 4 depicts a cross-sectional view of an optical fiber collimator array **400**, according to still another embodiment of the present invention. In general, the fiber collimator array **400** provides an alternative to the fiber collimator array **300** that is particularly useful when alignment of the block **302** and substrate **304** is burdensome or when the thickness of the substrate **304** cannot be easily controlled to within about ten microns. As shown in FIG. 4, a fiber array block **402** retains a plurality of optical fibers **408**. An angled surface **412** of the fiber array block **402** is coupled (e.g., with an index-matched optical adhesive **410A**) to a slanted surface **434** of an index-matched angled spacer **432**. If desired, an AR coating **410B** may also be provided at the interface between the block **402** and the spacer **432**. The spacer **432** includes a back surface **430** that is opposite the slanted surface **434**. The slanted surface **434** of the spacer **432** is preferably formed at an angle that is different from the angled surface **412**, of the fiber array block **402**. A back surface **414** of the microlens array substrate **404** is then adjusted in relation to the back surface **430**, of the spacer **432**, such that each optical beam axis coincides with an optical axis of one of the microlenses **406**. When proper alignment is achieved between the substrate **404** and the spacer **432**, the two are coupled together, preferably, with an index-matched optical adhesive **420**. In this configuration, the reflection from the microlens surface **416**, of the microlens array substrate **404**, can be reduced by adding an AR coating **418** to the surface **416**.

[0036] FIG. 5 illustrates a cross-sectional view of an optical fiber collimator array **500**, according to a different embodiment of the present invention. In the embodiment of FIG. 5, all surfaces of the array **500**, that an optical beam crosses, are substantially perpendicular, at least initially, to the optical axis of each microlens **506**. A fiber array block **502** retains a plurality of optical fibers **508** and includes a first surface **512** that is coupled (e.g., with an index-matched optical adhesive **511**) to a first surface **534** of an index-matched spacer **532**. The spacer **532** includes a second surface **530** that is opposite the first surface **534**. A microlens surface **516** of the microlens array substrate **504** is then adjusted in relation to the second surface **530** such that the optical beams coincide with the optical axis of each of the microlenses **506**.

[0037] When proper alignment is achieved between the substrate **504** and the spacer **532**, they are coupled together, preferably, with an index-matched optical adhesive **513A**. If desired, an AR coating **513B** may also be provided at the interface between the spacer **532** and the substrate **504**. The refractive index of the spacer **532** is preferably matched to the refractive index of the core of the optical fiber **508**. A reflection reduction of approximately 20 dB is achievable due to the spacing, dictated by the width (dependent on the focal length of the microlenses **506**) of the spacer **532**, between the ends of the optical fibers **508** and the microlenses **506**. This is because the modefield of an optical beam from each of the fibers **508** diverge until they reach one of the microlenses **506**. In this configuration, the reflection from the microlens surface **516** of the microlens array substrate **504** can be reduced by adding an AR coating **513B** to the interface between the spacer **532** and the substrate

**504.** Further, the reflection from a back surface **514** of the array **504**, opposite the microlens surface **516**, can be reduced by adding an AR coating **515** to the surface **514** and further reduced by angle polishing the surface **514**.

[0038] FIG. 6 illustrates a cross-sectional view of an optical fiber collimator array **600**, according to another embodiment of the present invention. An optical fiber array block **602** retains a plurality of optical fibers **608** and includes an angled surface **612** that is coupled (e.g., with an index-matched optical adhesive **611A**) to a slanted surface **634** of an index-matched spacer **632**. If desired, an AR coating **611B** may also be provided at the interface between the spacer **632** and the block **602**. The spacer **632** includes a back surface **630**, opposite the angled surface **634**, that is generally perpendicular to the optical axes of microlens **606**. A microlens surface **616**, of the microlens array substrate **604**, is then adjusted in relation to the surface **630**, of the spacer **632**, such that the optical beams coincide with the optical beam axis of each of the microlenses **606**.

[0039] When proper alignment is achieved between the substrate **604** and the spacer **632**, they are coupled together, preferably, with an index-matched optical adhesive **613**. The refractive index of the spacer **632** is, preferably, matched to the refractive index of the microlens **606**. Further, any reflection from the surface **614** of the array **604**, opposite the microlens surface **616**, can generally be reduced by angle polishing the surface **614** and normally further reduced by adding an AR coating **615** to the surface **614**.

[0040] FIGS. 7A-7C illustrate a simplified procedure for fabricating the fiber collimator array **600** of FIG. 6. As shown in FIG. 7A, initially, the slanted surface **634** of the index-matched spacer **632** is attached to the angled surface **612** of the optical fiber array block **602**. The effective thickness (i.e., the length of the optical path in the spacer **632**) is passively adjusted using an alignment tool. Next, as is shown in FIG. 7B, the microlens surface **616** of the microlens array substrate **604** is actively aligned, preferably by using a mirror, with the back surface **630** of the spacer **632**. When proper alignment is achieved, the spacer **632** and microlens array substrate **604** are fixed in relation to one another with an index-matched optical adhesive **613**. Finally, as shown in FIG. 7C, the back surface **614** of the substrate **604** is angle polished and AR coated **615**, if required for the application.

[0041] FIG. 8 depicts a cross-sectional view of a fiber collimator array **800**, according to yet another embodiment of the present invention. A fiber array block **802** retains a plurality of optical fibers **808** and includes an angled surface **812**. A slanted surface **834** of a spacer **832** is adjusted with respect to the angled surface **812** until the optical beams provided through the optical fibers **808** are perpendicular to a back surface **830** of the spacer **832**. The block **802** and the spacer **832** are then fixed with an adhesive **811B**. If desired, an AR coating **811A** may also be utilized on the surface **812** of the block **802** to reduce reflections. A microlens surface **816** of the microlens array substrate **804** is then adjusted in relation to the surface **830** of the spacer **832** such that the optical beams coincide with the optical beam axis of each of the microlenses **806**. Preferably, the spacer **832** has a hole **809**, which allows the optical beams to pass from the ends of the optical fibers **808**, through air, to the microlens **806**.

[0042] When proper alignment is achieved between the substrate **804** and the spacer **832**, they are coupled together,

with an adhesive **813A**. However, in this embodiment an index-matched optical adhesive is not required since the optical beams travel through air. In this configuration, any reflection from the microlens surface **816**, of the microlens array **804**, can also typically be reduced by adding an AR coating **813B** to the surface **816**. Reflections from the surface **814**, opposite the microlens surface **816**, can also typically be reduced by angle polishing the surface **814** and by adding an AR coating **815** to the surface **814**, if required for the application.

[0043] When a spacer is located between the fiber array block and the microlens array substrate, as shown in FIGS. 4, 5, 6, 7A-7C and 8, it is desirable to CTE match the spacer with the fiber array block and the microlens array substrate for high property stability over a wide temperature range. Preferably, the spacer material is a glass material that is transparent in the applied wavelength range, except in the case of FIG. 8, the spacer material does not have to be transparent in the applied wavelength range. The glass material of the angled spacer of FIG. 4 is, preferably, selected to match the refractive index of the microlens array substrate. The glass material of the angled spacer of FIGS. 2, 3, 6 and 7A-7C is, preferably, selected to match the refractive index of the microlens.

[0044] A suitable angle for the angled surface of the fiber array blocks of FIGS. 1A-1C, 2, 3, 4, 6, 7A-7C and 8 is about  $8\pm 0.1$  degrees. It should be appreciated that the angle range is a function of the desired minimum reflection. For example, if a center angle of 8.5 degrees is utilized, a wider angular range of about  $\pm 0.6$  degrees provides an acceptable reflection reduction. An acceptable angle for the sloped surface of the microlens array substrate is about  $8\pm 0.5$  degrees. However, the angle of the sloped surface can typically vary somewhat as the position of the microlens array substrate to the fiber array block is adjusted actively in the fiber collimator array fabrication process. In the case of the array of FIG. 3, the center angle of the sloped surface is preferably adjusted to be a slightly different value from  $8\pm 0.5$  degrees, depending on the refractive index difference between the core of the fiber and the microlens array substrate. A similar angular range of  $\pm 0.5$  degrees from the center angle is also usually acceptable for the slanted surface of the angled spacers of FIGS. 4, 6, 7A-7C and 8. In the case of FIGS. 6, 7A-C and 8, the back surface of the microlens array substrate is, preferably, angle polished to an angle of  $1\pm 0.5$  degrees, since a minimum angle of 0.4 degrees reduces the reflectivity such that the collimator array attenuates reflections by at least about 60 dB. The back surface of the index-matched angled spacers of FIGS. 2 and 3 are also preferably angle polished to an angle of about  $1\pm 0.5$  degrees for similar reasons.

[0045] FIGS. 9A-9B show a cross-sectional view and a side view, respectively, of an exemplary spacer **832** that can be utilized in the array of FIG. 8. As previously discussed, with respect to FIG. 8, the slanted surface **834** is adjusted such that the back surface **830**, which faces the substrate, is perpendicular to the optical beams provided by the optical fibers **808**. FIG. 10 depicts a microlens array **900** with a non-flat lens surface **902** that can be utilized with many of the embodiments, disclosed herein. Further, while only linear arrays have been depicted, one of ordinary skill in the art will appreciate that the arrays, disclosed herein, can readily be expanded to two-dimensional arrays.

**[0046]** In summary, an optical fiber collimator array has been described that includes an optical fiber array block and a microlens array substrate. The optical fiber array block includes an angled surface and is configured to receive and retain a plurality of individual optical fibers, which carry optical signals. The microlens array substrate includes a plurality of microlenses integrated along a microlens surface and a sloped surface opposite the microlens surface. The microlens surface is coupled to the angled surface such that the optical signals from the individual optical fibers are each collimated by a different one of the integrated microlenses. According to another embodiment of the present invention, an optical fiber collimator array includes an optical fiber array block, a microlens array substrate and an index-matched spacer. The optical fiber array block is configured to receive and retain a plurality of individual optical fibers, which carry optical signals. The microlens array substrate includes a plurality of microlenses integrated along a microlens surface and the index-matched spacer couples the optical fiber array block to the microlens array substrate.

**[0047]** It will become apparent to those skilled in the art that various modifications to the preferred embodiment of the invention as described herein can be made without departing from the spirit or scope of the invention as defined by the appended claims.

The invention claimed is:

1. An optical fiber collimator array, comprising:

an optical fiber array block configured to receive and retain a plurality of individual optical fibers which carry optical signals, the optical fiber array block including an angled surface; and

a microlens array substrate including a plurality of microlenses integrated along a microlens surface, the microlens array substrate including a sloped surface opposite the microlens surface that is coupled to the angled surface such that the optical signals from the individual optical fibers are each collimated by a different one of the integrated microlenses.

2. The collimator array of claim 1, wherein the integrated microlenses are graded-index (GRIN) lenses.

3. The collimator array of claim 1, wherein the integrated microlenses are aspheric lenses.

4. The collimator array of claim 1, wherein the integrated microlenses are Fresnel lenses.

5. The collimator array of claim 1, wherein the sloped surface of the microlens array substrate is coupled to the angled surface of the optical fiber array block by an index-matched optical adhesive.

6. The collimator array of claim 1, wherein the microlens surface includes an anti-reflection (AR) coating.

7. The collimator array of claim 1, wherein the pitch of the integrated microlenses is about 250 microns.

8. The collimator array of claim 1, wherein the sloped surface of the microlens array substrate and the angled surface of the optical fiber array block are both at about eight degrees from perpendicular to the optical axes of the individual optical fibers.

9. The collimator array of claim 1, further including:

an index-matched angled spacer including a slanted surface and a perpendicular surface opposite the slanted surface, wherein the perpendicular surface is coupled to the microlens surface and the angle of the slanted

surface is different from that of the sloped surface of the microlens array substrate and the angled surface of the optical fiber array block.

10. The collimator array of claim 9, wherein the sloped surface of the microlens array substrate and the angled surface of the optical fiber array block are both at about eight degrees from perpendicular to the optical axes of the individual optical fibers and the slanted surface of the index-matched angled spacer is less than one degree from perpendicular to the optical axes of the microlenses.

11. The collimator array of claim 9, wherein the slanted surface of the index-matched angled spacer includes an anti-reflection (AR) coating.

12. The collimator array of claim 9, wherein the sloped surface of the microlens array substrate and the angled surface of the optical fiber array block are at different angles with respect to the optical axes of the individual optical fibers.

13. An optical fiber collimator array, comprising:

an optical fiber array block configured to receive and retain a plurality of individual optical fibers which carry optical signals;

a microlens array substrate including a plurality of microlenses integrated along a microlens surface; and

a spacer coupling the optical fiber array block to the microlens array substrate.

14. The collimator array of claim 13, wherein the microlens array substrate includes a sloped surface opposite the microlens surface, and wherein the microlens surface is coupled to the spacer.

15. The collimator array of claim 13, wherein the optical fiber array block includes an angled surface and the spacer includes a slanted surface and a back surface opposite the slanted surface, and wherein the slanted surface is coupled to the angled surface and the back surface is coupled to the microlens array substrate.

16. The collimator array of claim 15, wherein the back surface is coupled to the microlens surface and the microlens array substrate includes a sloped surface opposite the microlens surface.

17. The collimator array of claim 15, wherein the back surface is coupled to a surface opposite the microlens surface of the microlens array substrate.

18. The collimator array of claim 16, wherein the spacer includes a hole such that the optical signals provided by the optical fibers pass only through air before encountering one of the microlenses.

19. The collimator array of claim 13, wherein the integrated microlenses are graded-index (GRIN) lenses.

20. The collimator array of claim 13, wherein the integrated microlenses are aspheric lenses.

21. The collimator array of claim 13, wherein the integrated microlenses are Fresnel lenses.

22. The collimator array of claim 13, wherein the spacer is an index-matched spacer that is coupled to the optical fiber array block and the microlens array substrate by an index-matched optical adhesive.

23. The collimator array of claim 13, wherein the pitch of the integrated microlenses is about 250 microns.

24. The collimator array of claim 16, wherein the slanted surface of the spacer and the angled surface of the optical

fiber array block are both at about eight degrees from perpendicular to the optical axes of the individual optical fibers.

**25.** A method for fabricating a fiber collimator array, comprising the steps of:

providing an optical fiber array block configured to receive and retain a plurality of individual optical fibers which carry optical signals, the optical fiber array block including an angled surface;

providing an index-matched spacer coupling the optical fiber array block to the microlens array substrate, the index-matched spacer including a slanted surface and a back surface opposite the slanted surface;

adjusting the slanted surface of the index-matched spacer in relation to the angled surface of the optical fiber array block to provide a desired optical path length through the spacer;

attaching the slanted surface of the index-matched spacer to the angled surface of the optical fiber array block using an indexed-matched optical adhesive when the desired optical path length through the spacer is achieved;

providing a microlens array substrate including a plurality of microlenses integrated along a microlens surface;

adjusting the microlens array substrate in relation to the back surface of the optical fiber array block to provide maximum optical power through the microlenses; and

attaching the microlens surface of the microlens array substrate to the back surface of the optical fiber array block using an indexed-matched optical adhesive when maximum optical power is provided through the microlenses.

**26.** The method of claim 25, further including the step of:

polishing a back surface of the microlens array substrate at an angle to reduce reflections, wherein the back surface is the surface opposite the microlens surface.

**27.** The method of claim 26, further including the step of:

applying an anti-reflection (AR) coating to the back surface of the microlens array substrate to further reduce reflections.

**28.** A method for fabricating an optical fiber collimator array, comprising the steps of:

providing an optical fiber array block configured to receive and retain a plurality of individual optical fibers which carry optical signals, the optical fiber array block including an angled surface; and

providing a microlens array substrate including a plurality of microlenses integrated along a microlens surface, the microlens array substrate including a sloped surface opposite the microlens surface that is coupled to the angled surface such that the optical signals from the individual optical fibers are each collimated by a different one of the integrated microlenses.

**29.** The method of claim 28, wherein the integrated microlenses are graded-index (GRIN) lenses.

**30.** The method of claim 28, wherein the integrated microlenses are aspheric lenses.

**31.** The method of claim 28, wherein the sloped surface of the microlens array substrate is coupled to the angled surface of the optical fiber array block by an index-matched optical adhesive.

**32.** The method of claim 28, wherein the microlens surface includes an anti-reflection (AR) coating.

**33.** The method of claim 28, wherein the pitch of the integrated microlenses is about 250 microns.

**34.** The method of claim 28, wherein the sloped surface of the microlens array substrate and the angled surface of the optical fiber array block are both at about eight degrees from perpendicular to the optical axes of the individual optical fibers.

**35.** The method of claim 28, further including the step of:

providing an index-matched angled spacer including a slanted surface and a back surface opposite the slanted surface, wherein the back surface is coupled to the microlens surface and the angle of the slanted surface is different from that of the sloped surface of the microlens array substrate and the angled surface of the optical fiber array block.

**36.** The method of claim 35, wherein the sloped surface of the microlens array substrate and the angled surface of the optical fiber array block are both at about eight degrees from perpendicular to the optical axes of the individual optical fibers and the slanted surface of the index-matched angled spacer is less than one degree from perpendicular to the optical axes of the microlenses.

**37.** The method of claim 35, wherein the slanted surface of the index-matched angled spacer includes an anti-reflection (AR) coating.

**38.** The method of claim 35, wherein the sloped surface of the microlens array substrate and the angled surface of the optical fiber array block are at different angles with respect to the optical axes of the individual optical fibers.

**39.** A method for fabricating an optical fiber collimator array, comprising:

providing an optical fiber array block configured to receive and retain a plurality of individual optical fibers which carry optical signals;

providing a microlens array substrate including a plurality of microlenses integrated along a microlens surface; and

providing a spacer coupling the optical fiber array block to the microlens array substrate.

**40.** The method of claim 39, wherein the microlens array substrate includes a sloped surface opposite the microlens surface, and wherein the microlens surface is coupled to the spacer.

**41.** The method of claim 39, wherein the optical fiber array block includes an angled surface and the spacer includes a slanted surface and a back surface opposite the slanted surface, and wherein the slanted surface is coupled to the angled surface and the back surface is coupled to the microlens array substrate.

**42.** The method of claim 41, wherein the back surface is coupled to the microlens surface and the microlens array substrate includes a sloped surface opposite the microlens surface.

**43.** The method of claim 41, wherein the back surface is coupled to a surface opposite the microlens surface of the microlens array substrate.

**44.** The method of claim 42, wherein the spacer includes a hole such that optical signals provided by the optical fibers pass through air before encountering one of the microlenses.

**45.** The method of claim 39, wherein the integrated microlenses are graded-index (GRIN) lenses.

**46.** The method of claim 39, wherein the integrated microlenses are aspheric lenses.

**48.** The method of claim 39, wherein the spacer is an index-matched spacer that is coupled to the optical fiber

array block and the microlens array substrate by an index-matched optical adhesive.

**49.** The method of claim 39, wherein the pitch of the integrated microlenses is about 250 microns.

**50.** The method of claim 41, wherein the slanted surface of the spacer and the angled surface of the optical fiber array block are both at about eight degrees from perpendicular to the optical axes of the individual optical fibers.

\* \* \* \* \*