

Bidirectional Wavelength Add–Drop Multiplexer Using Multiport Optical Circulators and Fiber Bragg Gratings

Jungho Kim and Byoungho Lee, *Member, IEEE*

Abstract—We propose and experimentally demonstrate a new structure of bidirectional wavelength add–drop multiplexer using multiport optical circulators and fiber Bragg gratings. It has the sufficient suppression of the unwanted light caused by Rayleigh backscattering and optical reflection and is economical for the effective use of multiport optical circulators.

Index Terms—Add–drop multiplexer, bidirectional transmission, fiber gratings, optical networks, wavelength-division multiplexing.

I. INTRODUCTION

THE EXPLOSIVE growth of data traffic drives the deployment of wavelength-division-multiplexing (WDM) technology. Single fiber bidirectional ring networks (SFBRN's) attract a great deal of attention due to their cost-effectively enhanced capacity and possibility of self-healing characteristic [1]. A bidirectional wavelength add–drop multiplexer (B-WADM) is one of the important components to implement SFBRN's. Several different structures of B-WADM using a WDM multiplexer/demultiplexer or an arrayed-waveguide grating (AWG) have been proposed and demonstrated [2]–[4]. In this paper, we propose a reconfigurable B-WADM using multiport optical circulators (OC's) and fiber Bragg gratings (FBG's). The proposed B-WADM has a good filtering shape and sufficiently suppresses the relative intensity noise (RIN) caused by Rayleigh backscattering and optical reflection owing to the filtering characteristic of FBG's. In addition, it is cost-effective because it makes an effective use of multiport OC's.

II. CONFIGURATION OF B-WADM

Fig. 1(a) shows the schematic diagram of the proposed B-WADM that can switch three optical channels in each direction. The reflective center wavelength of the FBG i ($i = 1, 2, \dots, N$) is designed to match the optical channel λ_i . Three optical channels in each direction enter port 2 of each six-port OC, and they are reflected by their corresponding FBG's that are connected to port 3 of the six-port OC. If these gratings are chirped, they can simultaneously provide

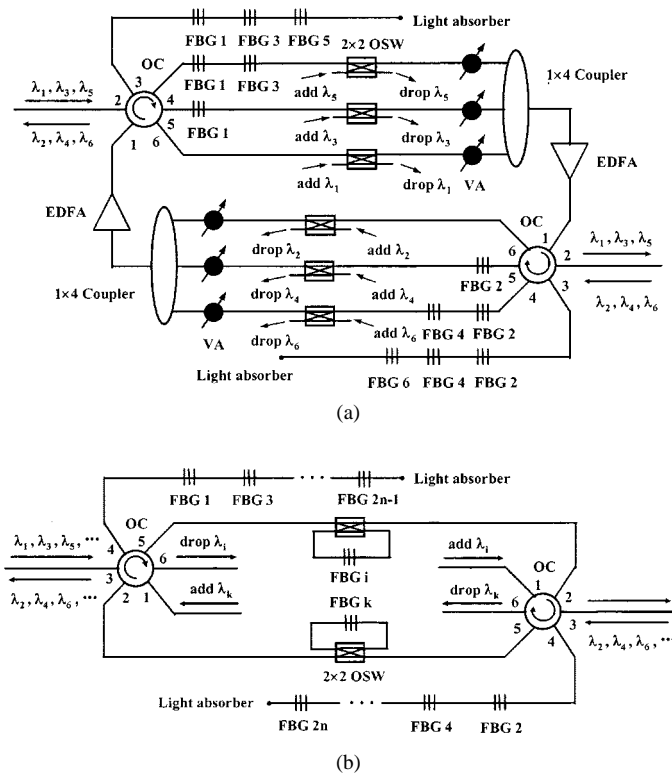

Fig. 1. (a) Schematic diagram of the proposed B-WADM that can switch three optical channels in each direction. (VA: variable attenuator.) (b) Schematic diagram of the proposed B-WADM that can switch only one optical channel in each direction.

dispersion compensation for the reflected optical channels. Because only two FBG's are connected to port 4 of the OC, one optical channel passes through two FBG's and enters a 2×2 optical switch (OSW). The other two optical channels are reflected again by their respective FBG's and sent to the next port of the OC. In the same manner, other optical channels are separated and enter a 2×2 OSW, respectively. A 2×2 OSW decides the operation state between "pass through" and "add-drop" of each optical channel. Optical channels leaving each 2×2 OSW ("pass through" or "added" channels) are combined by a $1 \times N$ coupler and exit the B-WADM through the other six-port OC. If a wavelength multiplexer (MUX) replaces a $1 \times N$ coupler, it reduces the insertion loss but adds cost to the system. Erbium-doped fiber amplifiers (EDFA's) for compensating the loss of the module and the fiber link and optical attenuators for optical power equalization are inserted in the B-WADM.

Manuscript received December 14, 1999; revised February 1, 2000. This work was supported in part by the Ministry of Science and Technology of Korea through Korea Telecom and KAIST.

The authors are with the School of Electrical Engineering, Seoul National University, Seoul 151-742, Korea (e-mail: byoungbo@plaza.snu.ac.kr).

Publisher Item Identifier: S 1041-1135/00/03597-7

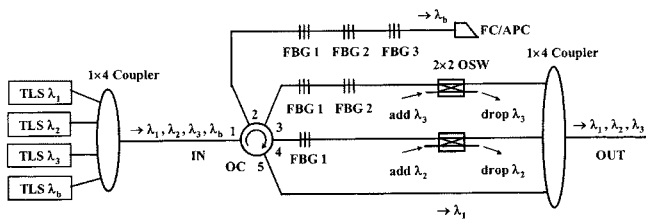

Fig. 2. Experimental setup of the proposed B-WADM. (TLS: Tunable light source.)

In a general bidirectional transmission system, the RIN induced by Rayleigh backscattering and optical reflection may degrade the receiver sensitivity. In addition, the maximum gain of the optical amplifier used in a bidirectional transmission system is limited by the multiple path reflection noise caused by Rayleigh backscattering and optical reflection. However, in our proposed B-WADM, these effects can be suppressed sufficiently by using FBG's. When the counterpropagating optical channels are in different wavelengths, the unwanted optical signals induced by Rayleigh backscattering and optical reflection pass through the FBG's that are connected to port 3 of a six-port OC and are filtered out by a light absorber.

In the proposed B-WADM, the six-port OC with corresponding FBG's can be regarded as a wavelength demultiplexer (DEMUX). Compared with conventional DEMUX such as an AWG and a multilayer interference-filter-based filter, this DEMUX has the good filtering shape that is ascribed to the filtering characteristics of FBG. Furthermore, because two six-port OC's simultaneously include the function of separating two unidirectional transmission optical signals from the bidirectional transmission optical signals, we do not need dummy three-port OC's used in the previous structures [3], [4].

The proposed B-WADM has good design flexibility. Fig. 1(b) shows the schematic diagram of the proposed B-WADM that can switch only one optical channel in each direction. The FBG's and light absorber that are connected to port 4 of a six-port OC suppress the unwanted optical signals induced by Rayleigh backscattering and optical reflection. If a 2×2 OSW is in bar state, all optical channels pass through. Only one optical channel whose wavelength matches with the FBG can be dropped or added when a 2×2 OSW is in cross-state. Compared with the structures of B-WADM using a WDM multiplexer/demultiplexer or an AWG, it may be the fittest for a B-WADM node that switches only one optical channel because it has a low insertion loss and a low cost.

III. EXPERIMENTAL RESULTS

Fig. 2 shows the experimental setup. Since the configuration of the proposed B-WADM is symmetric and there is no mutual influence between counterpropagating signals in the system, we perform experimental demonstration on only one side of the B-WADM. The average insertion loss of a six-port OC (E-Tek PIFC2610TER01) is 1.0 dB, and the isolation between adjacent ports of the OC's is >50 dB, respectively. The 2×2 OSW's used here are optomechanical switches with an insertion loss of

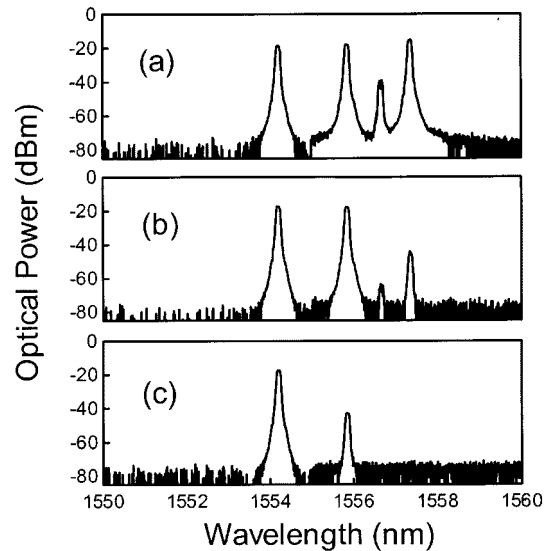

Fig. 3. Optical spectra obtained at port OUT. The resolution bandwidth of the optical spectrum analyzer is 0.1 nm. (a) When all optical channels pass through, (b) when the optical channel λ_3 is dropped, and (c) when both the optical channel λ_2 and λ_3 are dropped.

optical channels. The reflective center wavelengths of FBG's are $\lambda_1 = 1554.24$ nm, $\lambda_2 = 1555.84$ nm, and $\lambda_3 = 1557.44$ nm with 1.6-nm channel spacing. The 3-dB bandwidth and reflectivity of the FBG's are 0.4 nm and 25 dB, respectively. We use an FC/APC connector as a light absorber to prevent optical signals arriving at the light absorber from being reflected.

Three tunable laser diodes whose wavelengths are matched with the reflective center wavelengths of the FBG's are launched into port IN. To demonstrate the feasibility of suppressing the unwanted signals caused by Rayleigh backscattering from the counterpropagating light and optical reflection with different wavelengths, another optical channel λ_b for simulating the unwanted back-reflected (copropagating with λ_1 , λ_2 , and λ_3) signal is added. The wavelength of λ_b is 1556.64 nm, which is in the middle of optical channel λ_2 and λ_3 . The input optical power of each optical channel is around -5 dBm at port IN.

Fig. 3(a)–(c) shows the optical spectra obtained at the port OUT for different connection states of two OSW's. In Fig. 3(a), the crosstalk between channel λ_b and the other channels is about -20 dB when the input optical power of λ_b is the same as that of λ_1 , λ_2 , or λ_3 . In general, the reflection induced by Rayleigh backscattering in a long optical fiber (>20 km) is about -32 dB [5]. Therefore, the crosstalk of -20 dB may be sufficient for suppressing the RIN caused by Rayleigh backscattering. Moreover, using narrower reflection spectra of FBG's or larger channel spacing can further enhance the suppression of λ_b . The crosstalk between channel λ_b and the other channels is due to the nonideal rolloff of the FBG spectrums. Even if the center wavelengths of the FBG's are not matched with λ_b , a small portion of λ_b light is reflected by the nonideal rolloff of the FBG's. As the number that λ_b is reflected by the rolloff of the FBG's increases, optical channel λ_b is more suppressed. Fig. 3(c) shows the optical spectra

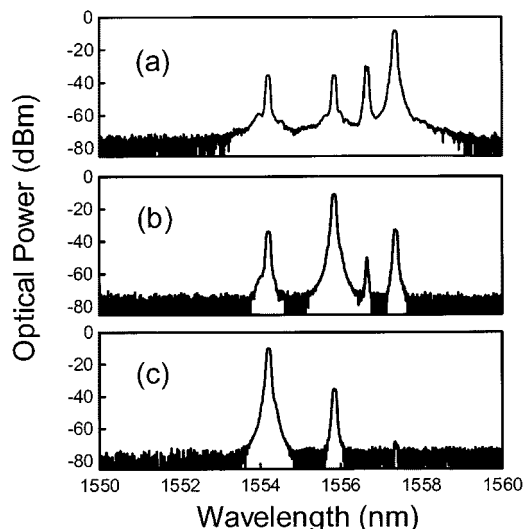

Fig. 4. Optical spectra of dropped optical channels at different locations. The resolution bandwidth of the optical spectrum analyzer is 0.1 nm. (a) Dropped optical channel λ_3 , (b) dropped optical channel λ_2 , and (c) dropped optical channel λ_1 .

channel λ_1 is about -60 dB because optical channel λ_b that is reflected by the nonideal rolloff FBG's three times arrives at the port OUT. Therefore, we cannot see λ_b in Fig. 3(c) because the power level of optical channel λ_b is lower than the noise level of the optical spectrum analyzer (OSA).

Since the optical channel λ_1 is reflected by three individual FBG 1's, the reflective center wavelengths of the FBG's should be very identical. Otherwise, the small wavelength misalignment may induce a large power penalty and signal-level degradation. In our experiment, the problem of wavelength misalignment does not occur seriously because the 3-dB bandwidth of the FBG used in the experiment is as wide as 0.4 nm. In addition, the reflectivity of three individual FBG 1's should be very high to prevent the problems of the homodyne crosstalk from the optical channel λ_1 . According to the theoretical analysis of the homodyne crosstalk, a homodyne crosstalk level of less than -30 dB may induce a power penalty less than 1 dB at a bit error rate (BER) of 10^{-9} [6]. To avoid the problem of homodyne crosstalk in our system, more than 30-dB reflectivity of FBG's should be used.

Fig. 4(a)–(c) shows the dropped signals at different locations. The optical spectrum of the dropped channel λ_1 is obtained by disconnecting port 5 of a six-port OC from the 1×4 coupler. In Fig. 4(c), the power level of optical channel λ_3 is near the noise level of OSA. The reason is that the optical signal λ_3 that is reflected by the nonideal rolloff of FBG's twice arrives at port 5 of the multiport OC. In Fig. 4, the heterodyne crosstalk between the dropped channel and the other channels is about -20 dB. In WDM systems, less than -15 -dB heterodyne crosstalk may induce a power penalty less than 0.5 dB at a BER of 10^{-9} [7]. Increasing the steepness of the rolloff of the FBG and the reflectivity of the FBG would improve the add-drop performances.

IV. SUMMARY

A new structure of B-WADM using multiport OC's and FBG's is proposed. It has good filtering characteristics and uses multiport OC effectively. In addition, it has good design flexibility. In our experiment, the suppression of the unwanted light caused by Rayleigh backscattering counterpropagating signals is more than 20 dB, but this can be further reduced using the FBG's of narrower reflective bandwidth or larger channel spacing.

REFERENCES

- [1] C. H. Kim, C. H. Lee, and Y. C. Chung, "Bidirectional WDM self-healing ring network on simple bidirectional add-drop amplifier modules," *IEEE Photon. Technol. Lett.*, vol. 10, no. 9, pp. 1340–1342, 1998.
- [2] K.-P. Ho and S.-K. Liaw, "Eight-channel bidirectional WDM add/drop multiplexer," *Electron. Lett.*, vol. 34, no. 10, pp. 947–948, 1998.
- [3] C. H. Kim, C. H. Lee, and Y. C. Chung, "A novel bidirectional add-drop amplifier," *IEEE Photon. Technol. Lett.*, vol. 10, no. 8, pp. 1118–1120, 1998.
- [4] Y. Zhao, X. J. Zhao, J. H. Chen, and F. S. Choa, "A novel bidirectional add-drop module using waveguide grating routers and wavelength channel matched fiber gratings," *IEEE Photon. Technol. Lett.*, vol. 11, no. 9, pp. 1180–1182, 1999.
- [5] N. Henmi, Y. Aoki, S. Fujita, Y. Sunohara, and M. Shikada, "Rayleigh scattering influence on performance of 10 Gb/s optical receiver with Er-doped optical fiber preamplifier," *IEEE Photon. Technol. Lett.*, vol. 2, no. 4, pp. 277–278, 1990.
- [6] K.-P. Ho, "Analysis of homodyne crosstalk in optical networks using Gram-Charlier series," *J. Lightwave Technol.*, vol. 17, no. 2, pp. 149–154, 1999.
- [7] K.-P. Ho and S.-K. Liaw, "Demultiplexer crosstalk rejection requirements for hybrid WDM system with analog and digital channels," *IEEE Photon. Technol. Lett.*, vol. 10, no. 5, pp. 737–739, 1998.