

FUJITSU NETWORK COMMUNICATIONS, INC.,
CORIANT OPERATIONS, INC., CORIANT (USA) INC.,
and CIENA CORPORATION

v.

CAPELLA PHOTONICS INC.

IPR2015-00726 (Patent No. RE42,368)¹
IPR2015-00727 (Patent No. RE42,678)²

May 24, 2016

¹ Case IPR2015-01958 has been joined to this proceeding.

² Case IPR2015-01961 has been joined to this proceeding.

Instituted Grounds

Patent		Claims	References
'368	2	1, 2, 5, 6, 9-12, 15-21	Bouevitch and Carr
	3	1-4, 17, 22	Bouevitch and Sparks
'678	5	1, 9, 10, 13, 17, 19, 44, 53, 61, 64, 65	Bouevitch and Carr
	7	1-4, 19-23, 27, 29, 44-46, 61-63	Bouevitch and Sparks

I. Capella Invented a New Class of Optical Switches

II. No Motivation to Combine

- Hindsight
- Changes the Principle of Operation

III. Ports

- Collimator Ports vs. circulators
- Disavowal / Disclaimer
- The '217 Provisional

Capella Invented a New Class of Optical Switches

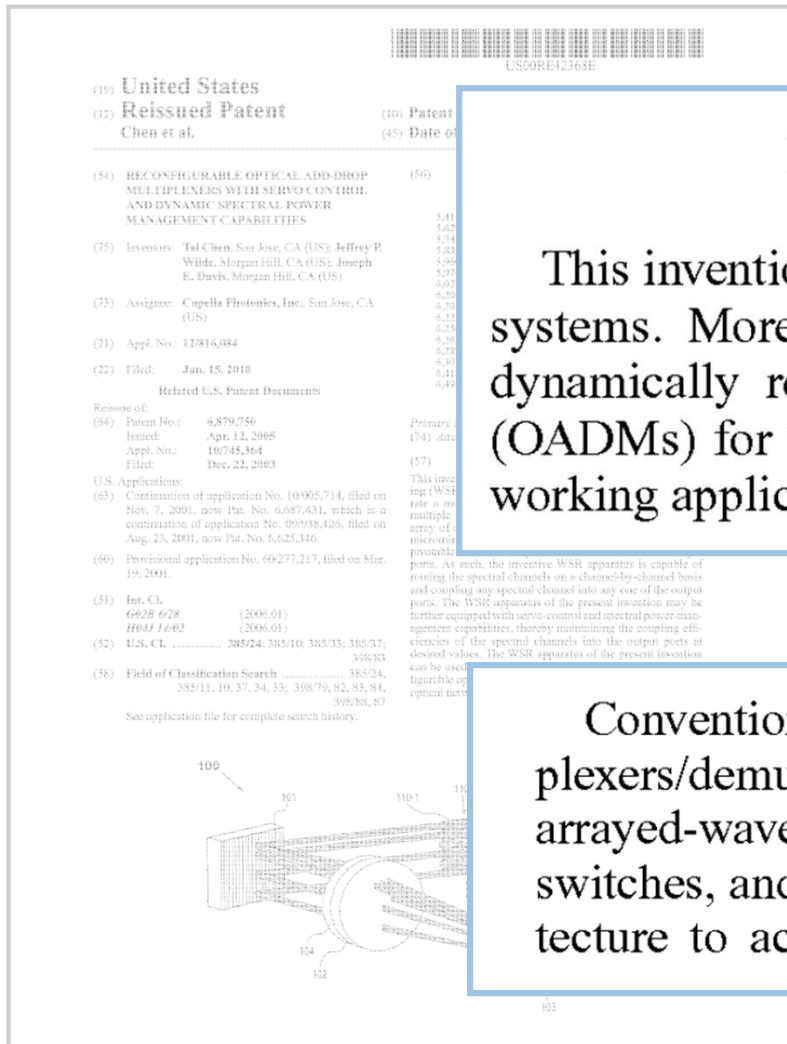

FIELD OF THE INVENTION

This invention relates generally to optical communication systems. More specifically, it relates to a **novel class** of dynamically reconfigurable optical add-drop multiplexers (OADMs) for wavelength division multiplexed optical networking applications.

Ex. 1001, 1:22-28; '726 POR, pp. 4, 5; '727 POR, p. 5

Conventional OADMs in the art typically employ multiplexers/demultiplexers (e.g, waveguide grating routers or arrayed-waveguide gratings), tunable filters, optical switches, and optical circulators in a parallel or serial architecture to accomplish the add and drop functions.

Ex. 1001, 1:59-63; '726 POR, p. 39; '727 POR, p. 39

Wavelength Add/Drop Multiplexers

Dr. Ford's 2006 Paper

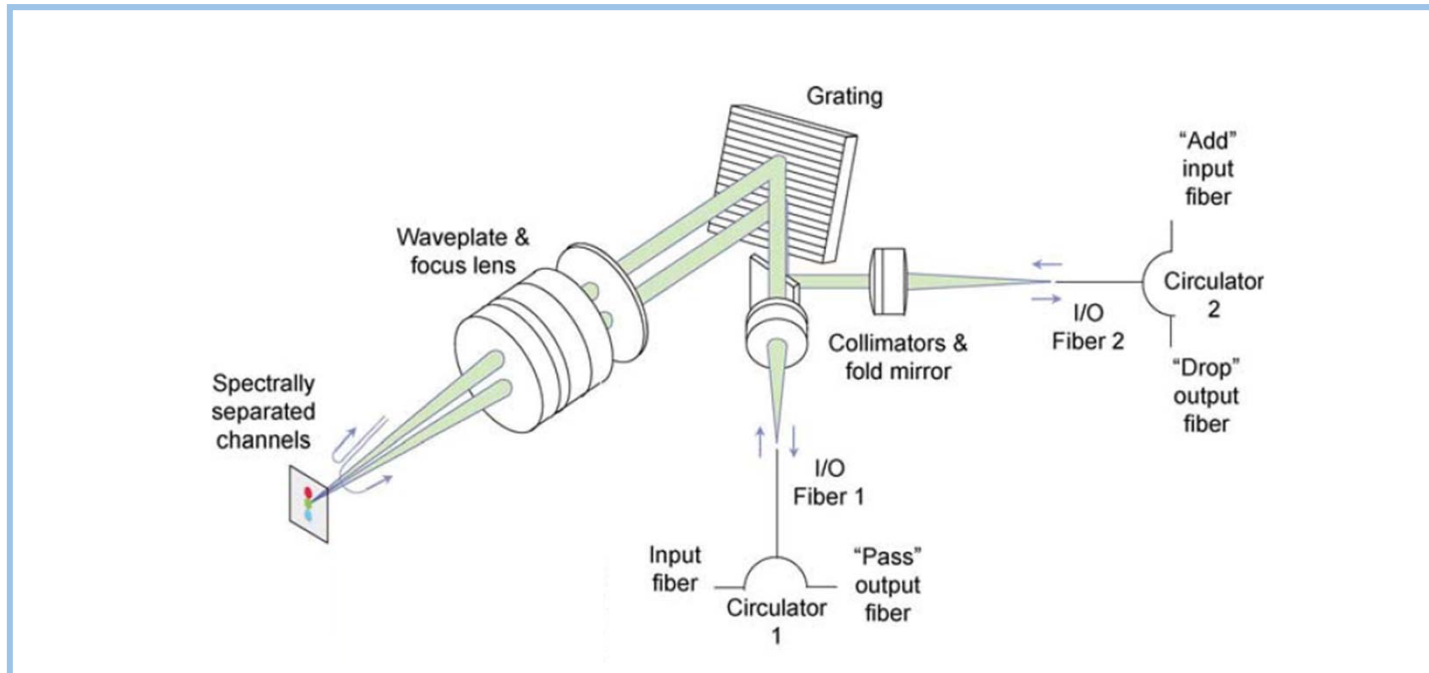

The most basic wavelength switch is the dynamically reconfigurable WADM, which is essentially a 1×2 or 2×2 optical switch operating independently on each wavelength channel.

Wavelength-Selective Switches

Dr. Ford's 2006 Paper

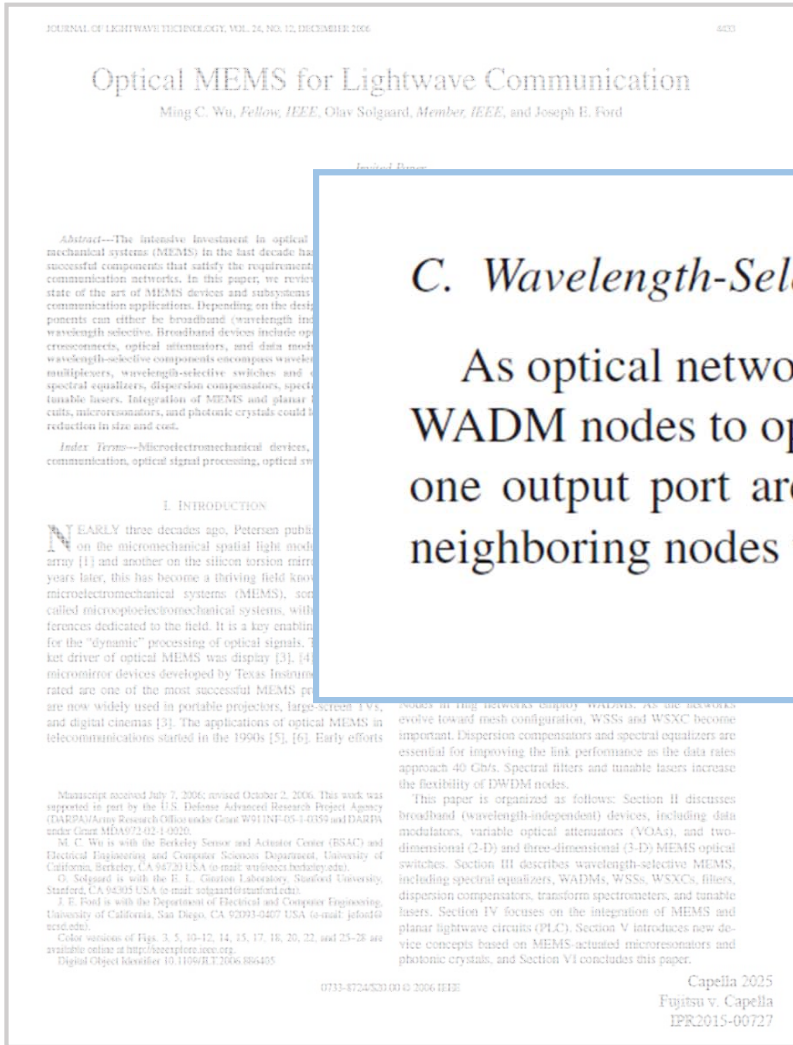

C. Wavelength-Selective Switches (WSSs)

As optical networks evolve from a simple ring topology with WADM nodes to optical mesh networks, WSSs with more than one output port are needed to link the node to three or four neighboring nodes with each link carrying two-way traffic.

Ex. 2025, p. 4439; '726 POR, pp. 32-34; '727 POR, pp. 32-34

Wavelength-Selective Switches

Key Features of a WSS

- (1) At Least Three Collimator Ports
- (2) Diffraction Grating
- (3) Switch **Any** Channel to **Any** Output Port

'726 POR, pp. 13-14; '727 POR, pp. 13-15

Ford's 2006 Paper

- (1) " N is larger than 2"
- (2) Diffraction Grating
- (3) "A large continuous scan angle is required to direct the output beam to any of the N output fiber collimators."

Ex. 2025, p. 4439; '726 POR, p. 14; '727 POR, p. 14

The '368 Patent Claims a WSS

Key Features of a WSS

- (1) At Least Three Collimator Ports
- (2) Diffraction Grating
- (3) Switch **Any** Channel to **Any** Output Port

'726 POR, pp. 13-14; '727 POR, pp. 13-15

Claim 1 of the '368 Patent

1. An optical add-drop apparatus comprising
an input port for an input multi-wavelength optical signal having first spectral channels;
one or more other ports for second spectral channels; an output port for an output multi-wavelength optical signal;
a wavelength-selective device for spatially separating said spectral channels; [and]
a spatial array of beam-deflecting elements positioned such that each element receives a corresponding one of said spectral channels, each of said elements being individually and continuously controllable *in two dimensions* to reflect its corresponding spectral channel to a selected one of said ports and to control the power of the spectral channel reflected to said selected port.

The '678 Patent Claims a WSS

Key Features of a WSS

- (1) At Least Three Collimator Ports
- (2) Diffraction Grating
- (3) Switch **Any** Channel to **Any** Output Port

'726 POR, pp. 13-14; '727 POR, pp. 13-14

Claim 1 of the '678 Patent

1. A wavelength-separating-routing apparatus, comprising:
 - a) multiple fiber collimators, providing an input port for a multi-wavelength optical signal and a plurality of output ports;
 - b) a wavelength-separator, for separating said multi-wavelength optical signal from said input port into multiple spectral channels;
 - c) a beam-focuser, for focusing said spectral channels into corresponding spectral spots; and
 - d) a spatial array of channel micromirrors positioned such that each channel micromirror receives one of said spectral channels, said channel micromirrors being **pivotal about two axes and being** individually and continuously controllable to reflect [[said]] **corresponding received** spectral channels into **any** selected ones of said output ports and to control the power of said received spectral channels coupled into said output ports.

Outline

I. Capella Invented a New Class of Optical Switches

II. No Motivation to Combine

- Hindsight
- Changes the Principle of Operation

III. Ports

- Collimator Ports vs. circulators
- Disavowal / Disclaimer
- The '217 Provisional

Hindsight

Legal Requirement

Obviousness rationale is through hindsight if: (1) knowledge goes beyond the skill of the art at the time of the invention; and (2) knowledge is gleaned only from the applicant's disclosure

In re McLaughlin, 443 F.2d 1392, 1395 (CCPA 1971)
'726 POR, p. 31; '727 POR, p. 31

Evidence Shows

- (1) Dr. Ford Incorrectly Assumes WSSs Existed at the time of the invention
- (2) Fujitsu's rationale comes from the Capella patent

'726 POR, pp. 31, 34; '727 POR, pp. 31, 34

Hindsight: Dr. Ford Assumes WSSs Existed

*Inter Partes Review of USPN RE42,368
Declaration of Joseph E. Ford, Ph.D. (Exhibit 1937)*

UNITED STATES PATENT AND TRADEMARK OFFICE

Dr. Ford's Declaration

V.	STATE OF THE ART AT THE TIME OF THE ALLEGED INVENTION	21
A.	Transparent optical switching prior to the alleged invention	21
B.	Reconfigurable Optical Add-Drop Multiplexers	22
C.	Wavelength Selective Switches	23

Mail Stop "PATENT BOARD"
Patent Trial and Appeal Board
U.S. Patent and Trademark Office
P.O. Box 1450
Alexandria, VA 22313-1450

Ford Dec., p. i; '726 POR, p. 31; '727 POR, p. 31

Hindsight: Dr. Ford Assumes WSSs Existed

Dr. Ford

Page 1

UNITED STATES PATENT AND TRADEMARK OFFICE
BEFORE THE PATENT TRIAL AND APPEAL BOARD

- - -

FUJITSU NETWORK COMMUNICATIONS, INC.

Petition

v.

CAPELLA PHOTO

Patent

- -

Inter Partes Review Case

Patent No.

AND

Inter Partes Review Case

Patent No.

- -

MILBANK, TWEED, HAD

28 LIBERTY

NEW YORK, NEW

DECEMBER 1

8:48 A

VIDEOTAPED DEPOSITION

JOSEPH E. FORD, PH.D.

REPORTED BY:

DEBRA SAPIO LYONS, RDR, CRR, CCR, CPE

JOB NO. PA 2199236

Q. And you talk about wavelength-selective switches in Paragraph 49 and 50 of your Declaration; correct?

A. Yes.

Q. In Paragraphs 49 and 50 there's not a single citation.

A. That's true.

Ford Depo. Tr., 203:15-18, 204:3-5; '726 POR, p. 32; '727 POR, p. 32

Hindsight: Dr. Ford Assumes WSSs Existed

JOURNAL OF LIGHTWAVE TECHNOLOGY, VOL. 24, NO. 12, DECEMBER 2006

4033

Optical MEMS for Lightwave Communication

Ming C. Wu, *Fellow, IEEE*, Olav Solgaard, *Member, IEEE*, and Joseph E. Ford

Invited

Abstract—The intensive investment in optical microelectromechanical systems (MEMS) in the last decade has led to many successful components that satisfy the requirements of lightwave communication networks. In this paper, we review the current state of the art of MEMS devices and subsystems for lightwave communication applications. Depending on the design, these components can either be broadband (wavelength independent) or wavelength selective. Broadband devices include optical switches, crossconnects, optical attenuators, and data modulators, while wavelength-selective components encompass wavelength add/drop multiplexers, wavelength-selective switches and crossconnects, spectral equalizers, dispersion compensators, spectrometers, and tunable lasers. Integration of MEMS and planar lightwave circuits, microprocessors, and photonic crystals could lead to further reduction in size and cost.

Index Terms—Microelectromechanical devices, optical fiber communication, optical signal processing, optical switches.

I. INTRODUCTION

N EARLY three decades ago, Petersen published a paper [1] on the micromechanical spatial light modulator (SLM) array [1] and another on the silicon torsion mirror [2]. Thirty years later, this has become a thriving field known as optical microelectromechanical systems (MEMS), sometimes also called microoptoelectromechanical systems, with several conferences dedicated to the field. It is a key enabling technology for the “dynamic” processing of optical signals. The first market driver of optical MEMS was display [3], [4]. The digital micromirror devices developed by Texas Instruments incorporated are one of the most successful MEMS products. They are now widely used in portable projectors, large-screen TVs, and digital cinemas [3]. The applications of optical MEMS in telecommunications started in the 1990s [5], [6]. Early efforts

Manuscript received July 7, 2006; revised October 2, 2006. This work was supported in part by the U.S. Defense Advanced Research Project Agency (DARPA)/Army Research Office under Grant W911NF-05-1-0359 and DARPA under Grant MDA972-02-1-0020.

M. C. Wu is with the Berkeley Sensor and Actuator Center (BSAC) and Electrical Engineering and Computer Science Department, University of California, Berkeley, CA 94720 USA (e-mail: wu@eecs.berkeley.edu).

O. Solgaard is with the E. L. Ginzton Laboratory, Stanford University, Stanford, CA 94305 USA (e-mail: solgaard@stanford.edu).

J. E. Ford is with the Department of Electrical and Computer Engineering, University of California, San Diego, CA 92093-0407 USA (e-mail: jeford@ucsd.edu).

Color versions of Figs. 3, 5, 10–12, 14, 15, 17, 18, 20, 22, and 25–28 are available online at <http://dx.doi.org/10.1109/JLT.2006.886403>.

0733-9724/06/\$20.00

Dr. Ford's 2006 Paper

In this paper, we review the current state of the art of MEMS devices and subsystems for lightwave communication applications.

Ex. 2025, 4433; '726 POR, pp. 32-34; '727 POR, pp. 32-34

III. WAVELENGTH-SELECTIVE MEMS

A. Spectral Equalizers

B. Wavelength Add/Drop Multiplexers

C. Wavelength-Selective Switches (WSSs)

D. Wavelength-Selective Crossconnects (WSXC)

'726 Ex. 2025, 4437-40; '726 POR, pp. 32-34; '727 POR, pp. 32-34

Hindsight: Dr. Ford Assumes WSSs Existed

Dr. Ford's 2006 Paper

Page 1

UNITED STATES PATENT AND TRADEMARK OFFICE

BEFORE THE PATENT TRIAL AND

- - -

FUJITSU NETWORK COMMUNICAT

Petitioner

v.

CAPELLA PHOTONICS, I

Patent Owner

- - -

Inter Partes Review Case No.

Patent No. RE42,34

AND

Inter Partes Review Case No.

Patent No. RE42,67

- - -

MILBANK, TWEED, HADLEY & M

28 LIBERTY STREET

NEW YORK, NEW YORK 1

DECEMBER 11, 2015

8:48 A.M.

VIDEOTAPED DEPOSITION

JOSEPH E. FORD, PH

REPORTED BY:

DEBRA SAPIO LYONS, RDR, CRR, CCR,

JOB NO. PA 2199236

Q. So there's like three columns of Subsection C; right?

A. Right.

Q. And in those three columns you cite 11 different references, References 80 through 90; correct?

A. Let's see. Yes.

Q. So those References 80 through 90 were all published after the March 2001 priority date of the patents at issue in this case.

A. That's true.

Ford Depo. Tr., 202:13-19, 207:11-23;
'726 POR, p. 34; '727 POR, p. 34

Hindsight: Dr. Ford Assumes WSSs Existed

Ranalli Reference

US006285500B1

(12) **United States Patent**
Ranalli et al.

(10) Patent No.: **US 6,285,500 B1**
(45) Date of Patent: **Sep. 4, 2001**

(54) **WAVELENGTH SELECTIVE SWITCH**

(75) Inventors: Eliseo R. Ranalli, Irvine; Bradley A. Scott, Huntington Beach, both of CA (US)

(73) Assignee: Corning Incorporated, Corning, NY (US)

(*) Notice: Subject to any disclaimer, the term of this patent is extended or adjusted under 35 U.S.C. 154(b) by 0 days.

(21) Appl. No.: 09/450,142
(22) Filed: Nov. 29, 1999

Related U.S. Application Data
(60) Provisional application No. 60/141,506, filed on Jun. 29, 1999.

(51) Int. Cl.⁷ G02B 5/30
(52) U.S. Cl. 359/497; 359/127; 359/494; 359/499; 365/11

(58) Field of Search 359/124, 127; 359/128, 130, 246, 494, 495, 497, 499; 365/11

(56) References Cited
U.S. PATENT DOCUMENTS
6,783,851 * 11/1998 Inou et al. 359/495

FOREIGN PATENT DOCUMENTS
WO9833289 7/1998 (WO)
WO9833281 8/1998 (WO)
* cited by examiner

Primary Examiner—Darron Schaberg
(74) Attorney, Agent, or Firm—Daniel P. Malley

(57) **ABSTRACT**
A reconfigurable bi-directional wavelength selective switch is disclosed. It has an optical system that is symmetric about a polarization modulator. The symmetric optical system consists of an input birefringent optical system and output birefringent optical system disposed around polarization modulator. The optical system delivers the wavelength channels that are to be switched as a superimposed wavelength channel incident the polarization modulator. As a result crosstalk is reduced below -35 dB and greater optical performance is achieved.

35 Claims, 9 Drawing Sheets

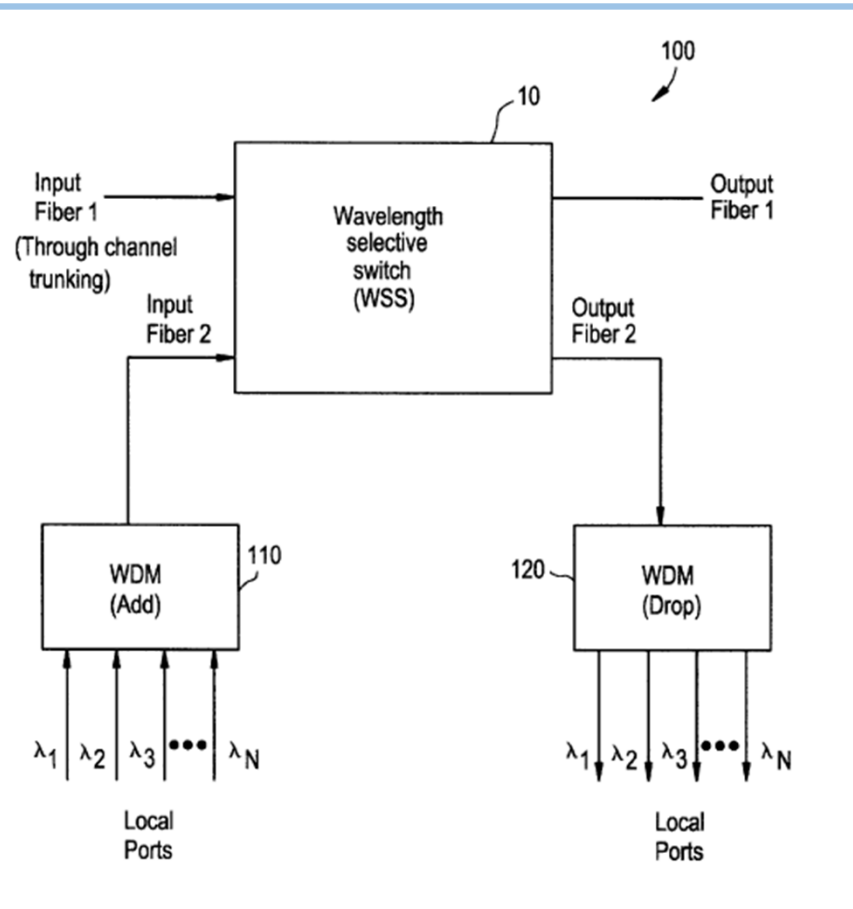

Ex. 1043, FIG. 10

Hindsight: Dr. Ford Assumes WSSs Existed

Dr. Sergienko

ALEXANDER V. SERGIENKO
UNITED STATES PATENT AND TRADEMARK OFFICE
BEFORE THE PATENT TRIAL AND APPEALS BOARD

FUJITSU NETWORK COMMUNICATIONS CORPORATION
Petitioner
v.
CAPELLA PHOTONICS,
Patent Owner

Case No. IPR2015-01001
Patent No. RE42,367
Patent No. RE42,671

DEPOSITION OF DR. ALEXANDER V. SERGIENKO
Washington, D.C.
February 1, 2015

Q. But in 1999, they called it a wavelength selective switch; right?

A. Well, one can put any name on the device. The question is, what's the functionality? Functionality defines the value of this invention or for the industry, so if you try to take this device and put it right next to the real wavelength selective switch, it will become obvious that this -- it doesn't fit.

* * *

And the name attached, to me personally, makes not much sense if I see the performance of the add/drop multiplexer.

Ex. 1040, 44:13-45:10

Hindsight: Dr. Ford Assumes WSSs Existed

Dr. Sergienko

ALEXANDER V. SERGIENKO
UNITED STATES PATENT AND TRADEMARK OFFICE
BEFORE THE PATENT TRIAL AND APPEALS BOARD

FUJITSU NETWORK COMMUNICATIONS CORPORATION
Petitioner
v.
CAPELLA PHOTONICS, INC.
Patent Owner

Case No. IPR2015-01001
Patent No. RE42,368
Patent No. RE42,671

DEPOSITION OF DR. ALEXANDER V. SERGIENKO
Washington, D.C.
February 1, 2015

A. This is not yes. I'm saying that someone can title the -- the patent. One has to examine the performance of this device and see whether it performs the functions of that it's not the wavelengths add/drop multiplexer. It is not a wavelength add/drop multiplexer following the definitions of Dr. Ford and his colleagues, who established the hierarchy of wavelength devices in telecommunication networks. I think this device would fall into the category of add/drop multiplexers.

Ex. 1040, 38:21-39:9

Hindsight: Fujitsu's Rationale Comes from the Capella Patent

UNITED STATES PATENT AND TRADEMARK OFFICE
BEFORE THE PATENT TRIAL AND APPEAL BOARD

FUJITSU NETWORK

CAPELLA
P

Inter Partes Review
Patent

PETITION FOR IN
U.S. PATENT NO. RE42,366
37 C.F.R. §§

Mail Stop "PATENT BOARD"
Patent Trial and Appeal Board
U.S. Patent and Trademark Office
P.O. Box 1450
Alexandria, VA 22313-1450

Fujitsu

Namely,

providing the MEMS mirrors of Bouevitch with two-axis tilt capability enables the spatial positioning of returning beams in both transverse directions at the face of microlens array 12. Thus, errors in system alignment arising, e.g., from imperfect assembly or temperature changes—well known problems in free space optical systems—could be better compensated.

'726 Petition, p. 26; '727 Petition, pp. 33, 45;
'727 Ford Dec., ¶¶ 155, 166

Hindsight: Fujitsu's Rationale Comes from the Capella Patent

(19) United States
(12) Reissued Patent
Chen et al.



(54) RECONFIGURABLE OPTICAL ADD-DROP MULTIPLEXERS WITH SERVO CONTROL AND DYNAMIC SPECTRAL POWER MANAGEMENT CAPABILITIES

(75) Inventors: Tai Chen, San Jose, CA (US); Jeffrey B. Wilde, Morgan Hill, CA (US); Joseph E. Davis, Morgan Hill, CA (US)

(73) Assignee: Capella Photonics, Inc., San Jose, CA (US)

(21) Appl. No.: 12/816,084

(22) Filed: Jun. 15, 2010

Related U.S. Patent Documents

Reissue of:
(64) Patent No.: 6,879,750
Issued: Apr. 12, 2005
Appl. No.: 10/745,364
Filed: Dec. 23, 2003

U.S. Applications:
(65) Continuation of application No. 10/925,714, filed on Nov. 7, 2001, now Pat. No. 6,687,431, which is a continuation of application No. 09/938,426, filed on Aug. 25, 2001, now Pat. No. 6,625,346.

(66) Provisional application No. 60/277,217, filed on Mar. 19, 2001.

(51) Int. Cl. G02B 6/28 (2006.01)
H04J 14/02 (2006.01)

(52) U.S. Cl. 385/24; 385/10; 385/33; 385/37; 398/83

(58) Field of Classification Search 385/24, 385/11, 10, 37, 34, 33, 398/79, 82, 83, 84, 398/81, 87

See application file for complete search history.

As such, the prevailing drawbacks suffered by the OADMs currently in the art are summarized as follows:

3) Stringent fabrication tolerance and painstaking optical alignment are required. Moreover, the optical alignment is not actively maintained, rendering it susceptible to environmental effects such as thermal and mechanical disturbances over the course of operation.

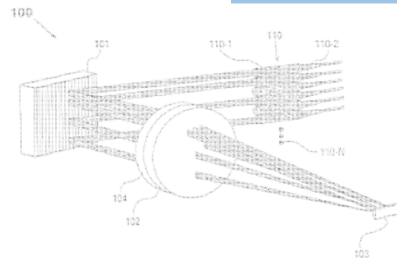

Ex. 1001, 3:20-21, 3:27-31; '726 POR, p. 35; '727 POR, p. 35

Hindsight: Fujitsu's Rationale Comes from the Capella Patent

(9) United States	(10) Patent No.
(12) Reissued Patent	(15) Date of Filing
Chen et al.	
(54) RECONFIGURABLE OPTICAL ADD-DROP MULTIPLEXERS WITH SERVO CONTROL AND DYNAMIC SPECTRAL POWER MANAGEMENT CAPABILITIES	(56)
(75) Inventors: Hui Chen, San Jose, CA (US); Jeffrey B. White, Morgan Hill, CA (US); Joseph E. Davis, Morgan Hill, CA (US)	5414.5 5429.7 5433.2 5435.4 5440.1 5474.2 5429.6
(73) Assignor: Capella Photonics, Inc., San Jose, CA (US)	6204.9 6205.2 6222.8 6236.6 6203.1 6236.1 6207.6 6418.2 6408.8
(31) Appl. No.: 12/816,084	
(32) Filed: Jun. 15, 2010	
Related U.S. Patent Documents	
Reissue of:	Priority Ex-
(64) Patent No.: 6,879,750	(74) Attorn-
Issued: Apr. 12, 2015	(57)
Appl. No.: 10/745,344	
Filed: Dec. 12, 2003	
U.S. Applications:	This inven-
(63) Continuation of application No. 10/041,714, filed on Nov. 7, 2001, now Pat. No. 6,877,411, which is a continuation of application No. 09/531,426, filed on Aug. 23, 2000, now Pat. No. 6,615,546.	ing (VSR) ap- patus is ca- pable of routing the spectral chan- nels on a chan- nel-by-chan- nel basis and creating any spectral chan- nel into any one of the out- put ports. The VSR ap- patus cap- able of directing any spec- trally op-
(60) Provisional application No. 60/277,217, filed on Mar. 19, 2001.	
(31) Int. Cl. (2006.01) 3802/4; 385/10; 345/33; 345/37; 390/03	
(32) U.S. Cl. (2006.01) 3802/4; 385/10; 345/33; 345/37; 390/03	
(38) Field of Classification Search: 3802/4, 3802/1, 19, 37, 34, 33, 398/75, 92, 83, 84, 392/38, 37	
See application file for complete search history.	

Third, the constituent optical components must be in a precise alignment, in order for the system to achieve its intended purpose. There are, however, no provisions provided for maintaining the requisite alignment; and no mechanisms implemented for overcoming degradation in the alignment owing to environmental effects such as thermal and mechanical disturbances over the course of operation.

Ex. 1001, 2:57-64; '726 POR, p. 35; '727 POR, p. 35

Moreover, as in the case of Askyuk et al., there are no provisions provided for maintaining requisite optical alignment in the system, and no mechanisms implemented for combating degradation in the alignment due to environmental effects over the course of operation.

Ex. 1001, 3:14-19; '726 POR, p. 35; '727 POR, p. 35

Outline

I. Capella Invented a New Class of Optical Switches

II. No Motivation to Combine

- Hindsight
- Changes the Principle of Operation

III. Ports

- Collimator Ports vs. circulators
- Disavowal / Disclaimer
- The '217 Provisional

Petitioners' Fundamental Assumption

Fujitsu

It would have been obvious to combine the teachings of Figure 11 of Bouevitch with the 2-axis MEMS mirrors of either Carr or Sparks.

A person of ordinary skill in the art would have been motivated use the 2-axis mirrors in Carr or Sparks instead of Bouevitch's 1-axis mirrors in part because both references use the same operating principles for both optical switching and power control. Those principles are (1) tilting mirrors at large angles to switch an optical signal from one port to another for switching functions in a Configurable Optical Add/Drop Multiplexer (COADM), and (2) tilting at smaller angles to slightly misalign the optical signal to control power for DGE (Dynamic Gain Equalization) functions. *See* Pet. at 34–36, 53–54.

UNITED STATES PATENT AND TRADEMARK OFFICE
BEFORE THE PATENT TRIAL AND APPEAL BOARD
FUJITSU NETWORKS, INC.
v.
CAPPELLA, INC.
Inter Partes Review
Patent No. 7,811,111 B2
PETITION FOR INTER PARTES REVIEW
U.S. PATENT NO. RE42,366
37 C.F.R. §§ 42.101-42.109

Mail Stop "PATENT BOARD"
Patent Trial and Appeal Board
U.S. Patent and Trademark Office
P.O. Box 1450
Alexandria, VA 22313-1450

'726 Reply, pp. 4-5; '727 Reply, pp. 4-5

Sparks Uses Misalignment to Control Power

Sparks

If, in accordance with an embodiment of the present invention, the optical beam path is misaligned, e.g. either to misalignment of one of the mirrors **16**, **26** or movement of the lens **22**, then **FIG. 2b** illustrates how only a portion of the beam **30** will be coupled into the optical fibre core **4a**. Consequently, only the fraction of the beam profile **30** coupled into the output forms the output signal, and hence the optical signal is attenuated.

US00625340B1

(12) **United States Patent**
Sparks et al.

(10) Patent No.:
(45) Date of Patent:

(54) **OPTICAL SWITCH ATTENUATOR**

(56) Refer
U.S. PATEN
6,031,945 A * 2/20
6,256,430 B1 * 7/20
6,424,757 B1 * 7/20
2002/0168131 A1 * 11/20
* cited by examiner

(75) Inventors: Adrian P. Sparks, Gagar (GB); Robert Spagnoletti, Telfordshire (GB); Gordon D. Horsfall, Harlow (GB)

(73) Assignee: Nortel Networks Limited, St. Laurent (CA)

(* Notice: Subject to any disclaimer, the term of this patent is extended or adjusted under 35 U.S.C. 154(b) by 0 days.

Primary Examiner—Kauf
(74) Attorney, Agent, or I
(57) AB

(21) Appl. No.: 09/474,544

(22) Filed: Dec. 29, 1999

(51) Int. Cl.⁷ G02B 6/26; G02B 6/42

(52) U.S. Cl. 385/18, 398/45

(58) Field of Search 359/117, 128, 385/16-18 12 Claims,

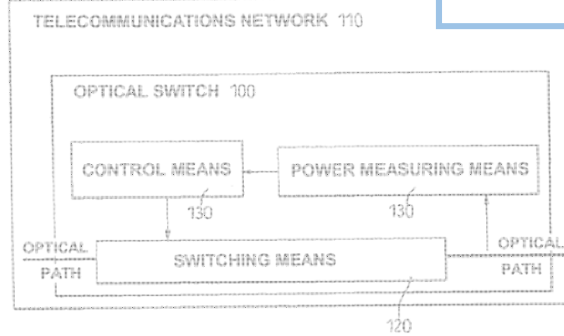

Sparks, 5:4-11; '726 POR, pp. 27-28; '727 POR, pp. 27-28

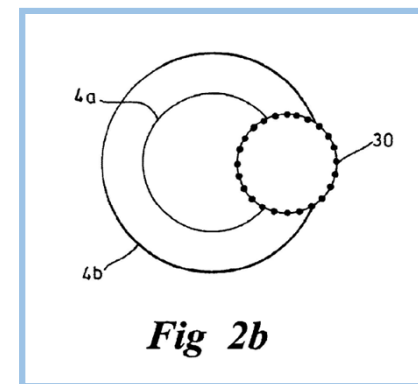
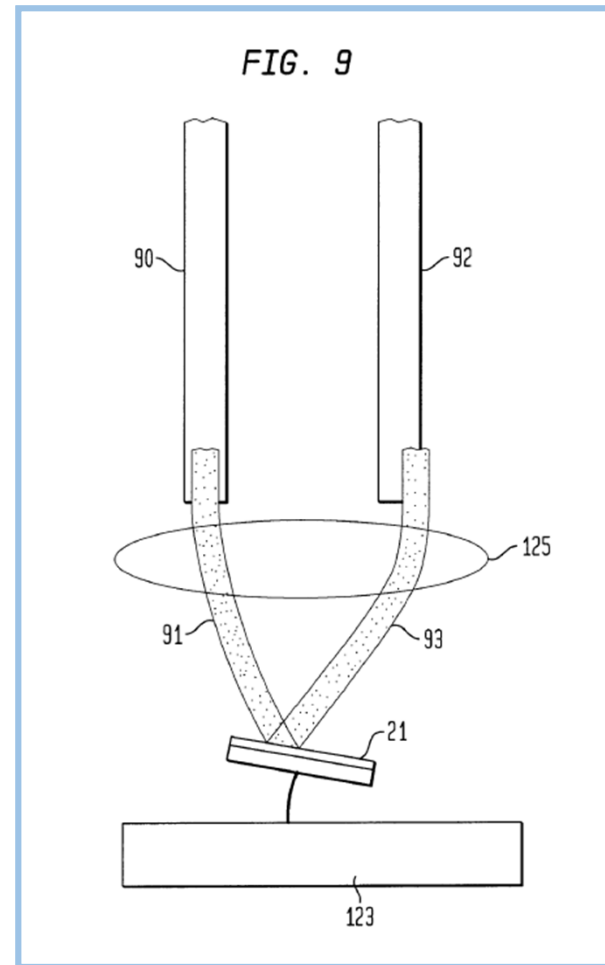
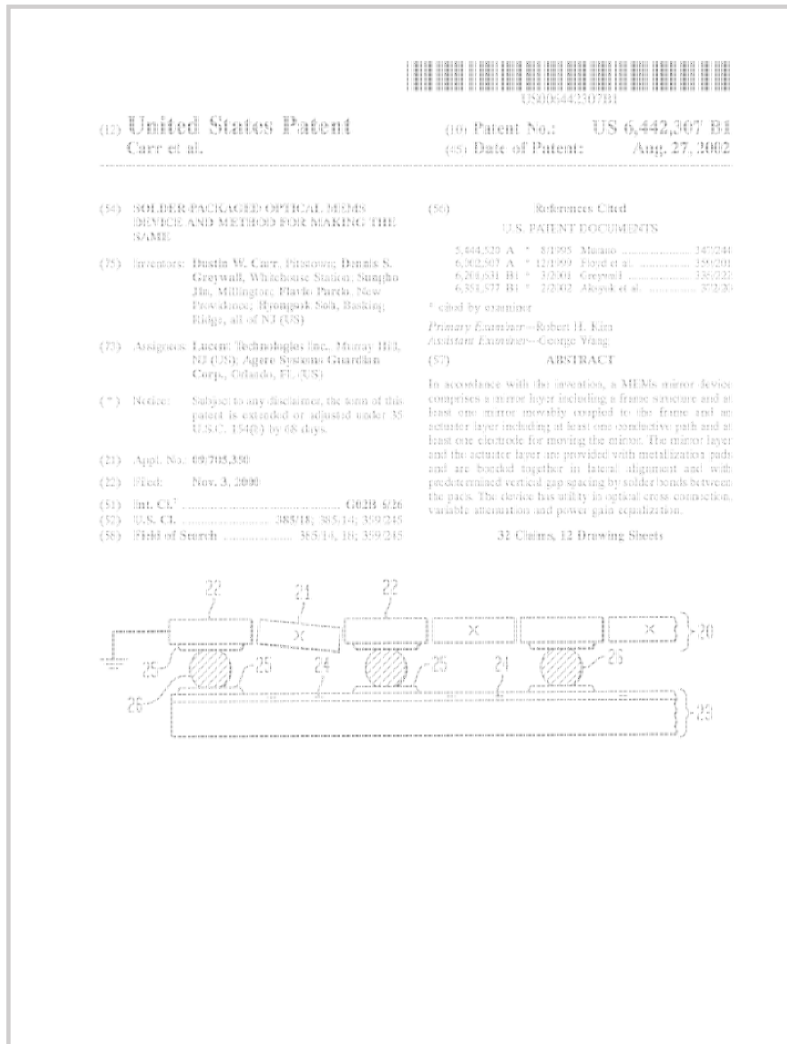

Fig 2b

Sparks, FIG. 2b;
'726 POR, p. 27; '727 POR, p. 27

Carr Uses Misalignment to Control Power

Carr



Carr, FIG. 9; '726 POR, p. 27; '727 POR, p. 27;

Boueitch Attenuates Power at a Modifying Means

(12) United States Patent Boueitch et al.

(54) OPTICAL CONFIGURATION FOR A DYNAMIC GAIN EQUALIZER AND A CONFIGURABLE ADD/DROP MULTIPLEXER

Boueitch, Title

The optical design includes a front-end unit for providing a collimated beam of light, an element having optical power for providing collimating/focusing effects, a diffraction element for providing spatial dispersion, and modifying means which in a preferred embodiment includes one of a MEMS array and a liquid crystal array for reflecting and modifying at least a portion of a beam of light. **The modifying means functions as an attenuator** when the optical device operates as a DGE and as a switching array when the optical device operates as a COADM.

Boueitch, Abstract

(12) United States Patent
Boueitch et al.

(10) Patent No.: US 6,498,872 B1
(45) Date of Patent: Dec. 24, 2003

(54) OPTICAL CONFIGURATION FOR A
DYNAMIC GAIN EQUALIZER AND A
CONFIGURABLE ADD/DROP
MULTIPLEXER

(75) Inventors: Oleg Bouevitch, Glencore (CA);
Thomas Ducebill, Ottawa (CA); W.
John Tomlinson, Princeton, NJ (US);
Paul Colbourne, Nepean (CA);
Jacques Bisnath, Ottawa (CA)

(73) Assignee: JDS Uniphase Inc., Ottawa (CA)

(*) Notice: Subject to any disclaimer, the term of this
patent is extended or adjusted under 35
U.S.C. 154(b) by 17 days.

(21) Appl. No.: 09/719,270

(22) Filed: Dec. 5, 2000

(65) Prior Publication Data

US 2002/0092257 A1 Jan. 24, 2002

Related U.S. Application Data

(60) Provisional application No. 60/383,155, filed on Feb. 17,
2000.

(51) Int. Cl.⁷ G02B 6/28; H01J 14/02

(52) U.S. Cl. 385/24; 385/37; 359/130;
359/246; 359/247; 359/301; 359/302; 359/128

(50) Field of Search 359/153, 196;
359/115, 122, 128, 124, 130, 131, 245-247,
301-302; 385/16, 38, 34, 31, 37, 39, 47

(56) References Cited

U.S. PATENT DOCUMENTS

4,207,080 A 11/1983 Green 260/44
4,707,036 A 11/1987 Binger 380/96,12
4,839,884 A 6/1989 Schloss 370/3
5,231,815 A 8/1993 McDaniel et al. 266/333
5,341,650 A * 5/1994 Asakawa et al. 380/337,34
5,414,540 A * 5/1995 Patel et al. 389/196
5,477,550 A 12/1995 Riva et al. 359/39
5,526,555 A 6/1996 Kern et al. 389/189

5,743,288 A 4/1998 Pan 386
5,782,271 A 4/1998 Ford et al. 359
5,867,631 A 12/1998 Tomlinson, III et al. 356
5,867,264 A 2/1999 Hararich 356
5,881,199 A 3/1999 Li 385
5,926,752 A 8/1999 Bishop et al. 356
5,943,128 A 8/1999 Ford et al. 359
5,964,133 A 8/1999 Tomlinson 386
6,030,603 A 12/2000 Landgraf et al. 386
6,081,531 A 6/2000 Trichman 356
6,134,259 A 10/2000 Keyworth et al. 386
6,415,080 B1 * 7/2002 Suppey et al. 356

* cited by examiner

Primary Examiner—Hemang Sanghani
Assistant Examiner—Omar Rojas
(78) Attorney, Agent, or Firm—Lacasse & Associates, L.L.C.

(57) ABSTRACT

An optical device for receiving and modifying an optical signal that is capable of operating as a dynamic gain equalizer (DGE) and a configurable add/drop multiplexer (COADM) includes a front-end unit for providing a collimated beam of light, an element having optical power for providing collimating/focusing effects, a diffraction element for providing spatial dispersion, and modifying means which in a preferred embodiment includes one of a MEMS array and a liquid crystal array for reflecting and modifying at least a portion of a beam of light. The modifying means functions as an attenuator when the optical device operates as a DGE and as a switching array when the optical device operates as a COADM.

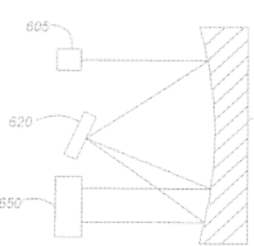

Bouevitch Attenuates Power at a Modifying Means

(12) United States Patent
Bouevitch et al.

(50) OPTICAL CONFIGURATION FOR A DYNAMIC GAIN EQUALIZER AND A CONFIGURABLE ADD-DROP MULTIPLEXER

(75) Inventors: Oleg Bouevitch, Ottawa (CA); Thomas Dattler, Ottawa (CA); W. John Tomlinson, Princeton, NJ (US); Paul Calhoun, Nepean (CA); Jacques Bostoft, Ottawa (CA)

(73) Assignee: JDS Uniphase Inc., Ottawa (CA)

(*) Notice: Subject to any disclaimer, the term of this patent is extended or adjusted under 35 U.S.C. 154(b) by 17 days.

(21) Appl. No.: 09/719,270

(22) Filed: Dec. 5, 2000

(65) Prior Publication Data
US 2002/009257 A1 Jan. 24, 2002

Related U.S. Application Data
(60) Provisional application No. 60/183,151, filed on Feb. 1, 2000.

(51) Int. Cl.⁷ G02B 3/08; H04J 14/00

(52) U.S. Cl. 385/24; 385/37; 359/110; 359/246; 359/247; 359/301; 359/302; 359/322

(58) Field of Search 359/115; 322; 428; 429; 430; 431; 245-297; 301-302; 385/16; 38; 24; 31; 37; 39; 4

(56) References Cited
U.S. PATENT DOCUMENTS
6,357,090 A 1/14/03 Gray 306-6
6,707,036 A 11/2/02 Hsiao 350/6-1
6,839,806 A 6/14/03 Schless 370
6,225,810 A 8/19/03 Weikert et al. 380/23
6,341,666 A 5/14/04 Avellan et al. 350/312
6,414,540 A * 5/19/03 Patel et al. 340/19
6,472,550 A 12/1/03 Raza et al. 305/5
6,526,110 A 6/1/00 Kay et al. 380/14

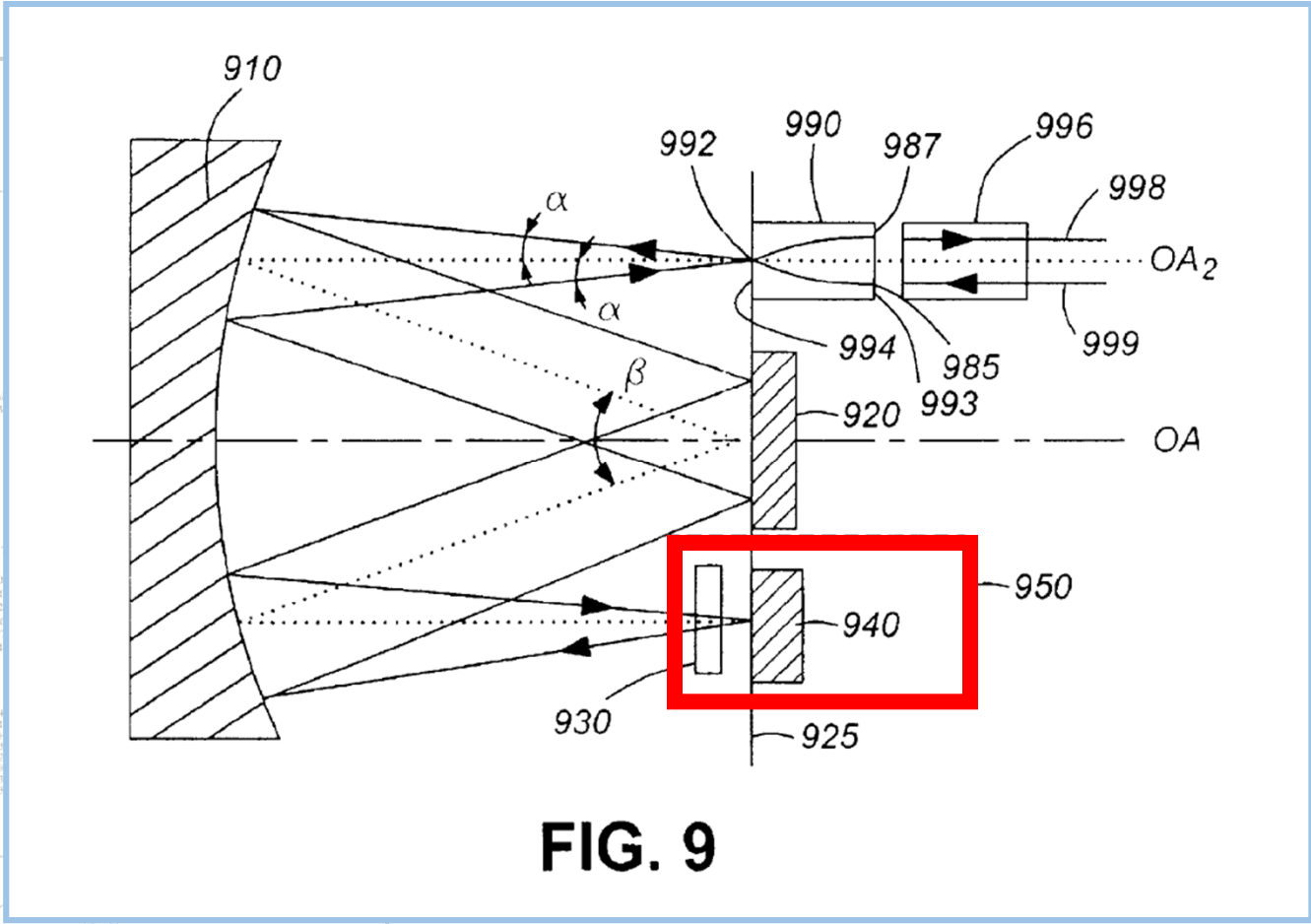

Bouevitch, FIG. 9; '726 POR, pp. 28-29; '727 POR, pp. 28-29

Boueitch Attenuates Power at a Modifying Means

(12) United States Patent
Boueitch et al.

(10) Patent No.: US 6,498,872 B2
(22) Date of Patent: Dec. 24, 2002

(56) OPTICAL CONFIGURATION
DYNAMIC GAIN EQUATION
CONFIGURABLE ADDITIVE
MULTIPLIER

(75) Inventors: Oleg Bouevitch
Thomas Ducloux
John Tomlinson
Paul Collinson
Jacques Blouin

(73) Assignee: JDS Uniphase

(*) Notice: Subject to any
prior art, this patent is
published under the
provisions of 35 U.S.C. 154(b) 1

(21) Appl. No. 09/719,270

(22) Filed: Dec. 5, 2000

(65) Prior Publication

US 2002/0092257 A1 Jan. 24,

2000

Related U.S. Appl.

(40) Provisional application No. 60

(51) Int. Cl.⁷

(52) U.S. Cl.

(50) Field of Search

(56) References Cited

U.S. PATENT DOCUMENTS

4,307,080 A 1/1983 Gou

4,707,036 A 12/1987 Boga

4,839,884 A 6/1989 Sack

5,231,815 A 8/1993 Sack

5,341,666 A * 5/1994 Arai

5,414,540 A * 5/1995 Pugh

5,471,550 A 12/1995 Rago

5,526,555 A 6/1999 Sant

Variable attenuation is provided by the modifying means **950**. The spherical reflector **910** redirects the modified spatially dispersed beam of light back to the diffraction grating **920** such that it is recombined to form a single modified output beam of light, which is incident on the single port **992** with an angle of incidence close to $-\alpha$. The attenuated output beam of light is passed through the lens **990**, and is directed towards output port **987** where it is transmitted to output optical fibre **998**.



Boueitch, 12:59-67; '726 POR, p. 28; '727 POR, p. 28

Bouevitch Attenuates Power at a Modifying Means

(12) United States Patent
Bouevitch et al.

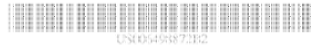

(10) Patent No.: US 6,490,872 B2
(45) Date of Patent: Dec. 24, 2002

(50) OPTICAL CONFIGURATION FOR A DYNAMIC GAIN EQUALIZER AND A CONFIGURABLE ADD-DROP MULTIPLEXER

(75) Inventors: Oleg Bouevitch, Ottawa (CA); Thomas Dattler, Ottawa (CA); W. John Tomlinson, Princeton, NJ (US); Paul Calhoun, Nepean (CA); Jacques Bisault, Ottawa (CA)

(73) Assignee: JDS Uniphase Inc., Ottawa (CA)

(*) Notice: Subject to any disclaimer, the term of this patent is extended or adjusted under 35 U.S.C. 154(b) by 17 days.

(21) Appl. No.: 09/719,270

(22) Filed: Dec. 5, 2000

(65) Prior Publication Data

US 2002/009257 A1 Jan. 24, 2002

Related U.S. Application Data

(60) Provisional application No. 60/053,151, filed on Feb. 28, 2000

(51) Int. Cl.⁷ G02B 3/08; H03J 1/10

(52) U.S. Cl. 385/24; 385/37; 389/11

(58) Field of Search 359/246; 359/247; 359/301; 359/302; 359/303

359/315; 322; 428; 429; 430; 431; 445-29

301-302; 385/16; 38; 24; 31; 37; 39;

(56) References Cited

U.S. PATENT DOCUMENTS

6,357,090 A 11/18/01 Gray 306

6,707,026 A 11/19/01 Hsueh 35006

6,839,806 A 07/18/01 Schless 37

7,225,410 A 07/29/01 Weikert et al. 3807

7,311,666 A 07/04/01 Avetisyan et al. 3803/37

7,414,530 A 07/19/01 Patel et al. 3807

7,472,530 A 12/19/01 Riza et al. 305

7,526,110 A 01/09/01 Kay et al. 3804

The spatially dispersed sub-beams of light incident on the lower region of the spherical reflector **810** are reflected and transmitted to the modifying means **850** in a direction parallel to the optical axis of the spherical reflector **810**. **Once attenuated, the sub-beams of light are reflected back to the spherical reflector **810**, the diffraction grating **820**, and the front-end unit **805** along the same optical path.**

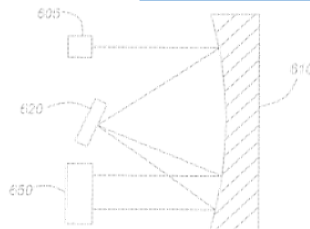

Bouevitch, 11:28-35; '726 POR, p. 28; '727 POR, p. 28

Boueivitch Attenuates Power at a Modifying Means

US 7,272,271 B2

(12) **United States Patent**
Boueivitch et al.

(10) Patent No.: US
(45) Date of Patent:

(56) OPTICAL CONFIGURATION FOR A DYNAMIC GAIN EQUALIZER AND A CONFIGURABLE ADDRESSROP MULTIPLEXER

(75) Inventors: Oleg Bouevitch, Glencoe (CA); Thomas Drexler, Ottawa (CA); W. John Tomlinson, Princeton, NJ (US); Paul Colbourne, Napa (CA); Jacques Bisnath, Ottawa (CA)

(73) Assignee: JDS Uniphase Inc., Ottawa (CA)

(*) Notice: Subject to any disclaimer, the term of this patent is extended to adjusted under 35 U.S.C. 154(b) by 17 days.

(21) Appl. No. 09/719,270

(22) Filed: Dec. 5, 2000

(65) Prior Publication Data
US 2002/0092257 A1 Jan. 24, 2002

Related U.S. Application Data
(60) Provisional applications No. 60/183,155, filed on Feb. 17, 2000.

(51) Int. Cl.⁷ G02B 6/28; H01H 14/02

(52) U.S. Cl. 385/24; 385/37; 359/130; 359/246; 359/247; 359/301; 359/302; 359/128

(50) Field of Search 349/193, 196; 359/115, 122, 128, 124, 130, 131, 245-247, 301-302; 385/16, 18, 24, 31, 37, 39, 47

(56) References Cited
U.S. PATENT DOCUMENTS
4,307,080 A 1/1983 Green 260-44
4,707,056 A 12/1987 Blaser 350/90, 12
4,839,884 A 6/1989 Schloss 370/3
5,231,815 A 8/1993 Robinson et al. 266/203
5,341,690 A * 5/1994 Asakawa et al. 309/337, 21
5,414,540 A * 5/1995 Patel et al. 369/196
5,477,550 A 12/1995 Riva et al. 359/39
5,526,155 A 6/1996 Kent et al. 369/189

41 Claims, 12 Drawing

After passing through the quarter waveplate **157** for a second time, the attenuated sub-beam of light will have a polarization state that has been rotated 90° from the original polarization state. As a result the attenuated sub-beam is refracted in the birefringent element **156** and is directed out of the device to port **102b**. A half wave plate **158** is provided to rotate the polarization of the refracted sub-beams of light by 90°.

Boueivitch, 7:37-44; '726 POR, p. 28; '727 POR, p. 28

Of course, other modifying means **150** including at least one optical element capable of modifying a property of at least a portion of a beam of light and reflecting the modified beam of light back in substantially the same direction from which it originated are possible.

Boueivitch, 7:45-49; '726 POR, p. 28; '727 POR, p. 28

Bouevitch Attenuates Power at a Modifying Means

Bouevitch

The degree of attenuation is based on the degree of deflection provided by the reflector (i.e., the angle of reflection).

Bouevitch, 7:35-37; '726 POR, p. 30; '727; POR, p. 30

Petitioner Reply

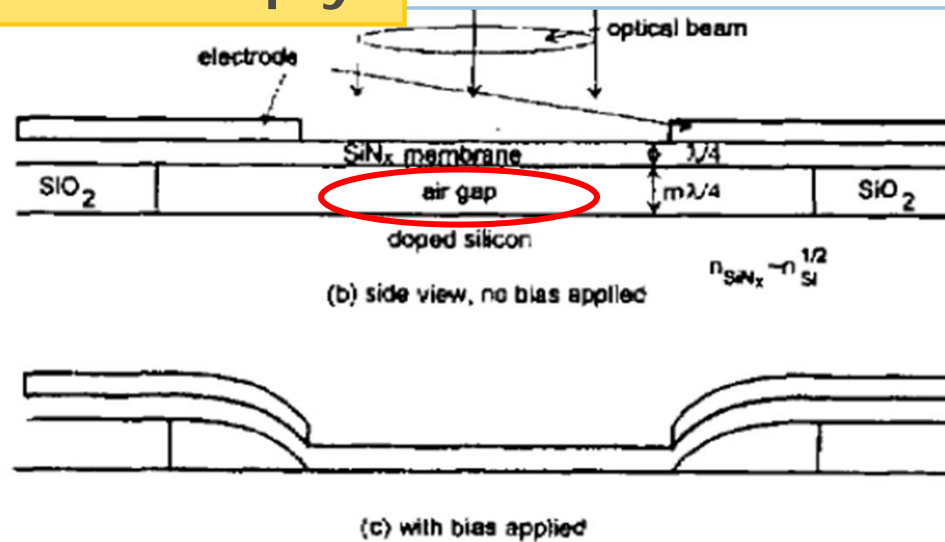

See '726 Reply, p. 9; '727 Reply, p. 9

The Figure 11 Embodiment Does Not Control Power

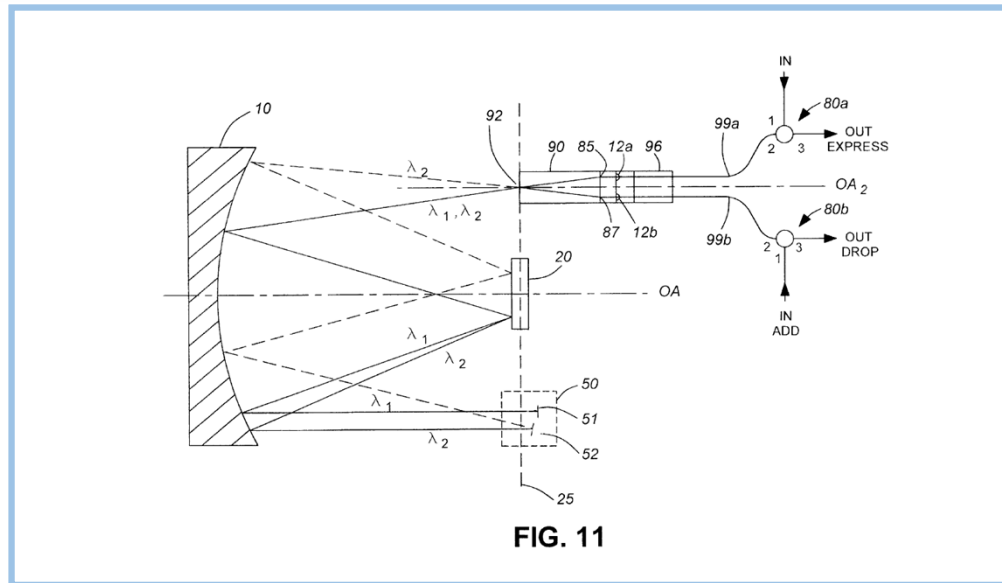

Boueitch, FIG. 11; '726 POR, p. 12; '727 POR, p. 12

FIG. 11 is a schematic diagram of the preferred embodiment of a **COADM** in accordance with the instant invention;

A preferred embodiment is illustrated in FIG. 11, wherein an arrangement similar to that shown in FIG. 9 **designed to operate as a COADM**, is shown.

Boueitch, 5:6-7, 14:14-16; '726 POR, p. 40; '727 POR, p. 40

Bouevitch Discourages Misalignment

USPO 49987262

(12) United States Patent
Bouevitch et al.

(11) Patent No.: US 4,498,872 B2
(45) Date of Patent: Dec. 24, 2002

(56) OPTICAL CONFIGURATION DYNAMIC GAIN EQUALIZER CONFIGURABLE ADD-DROP MULTIPLEXER

(75) Inventors: Oleg Bouevitch, Thomas Dacelle, John Tomlinson, Paul Colbourne, Jacques Bostain

(73) Assignee: JDS Uniphase Inc.

(*) Notice: Subject to any disclaimer, this patent is certified under 35 U.S.C. 154(b) to be prior art.

(21) Appl. No.: 09/719,270
(22) Filed: Dec. 5, 2000
(65) Prior Publication: US 2002/0029257 A1 Jan. 24, 2002

Related U.S. Applications
(60) Provisional application No. 60/239,393

(51) Int. Cl.⁷: H01L 31/03
(52) U.S. Cl.: 359/266; 359/247; 359/267

(58) Field of Search: 359/215; 359/225; 359/230; 359/240; 359/250; 359/260; 359/270

(56) References Cited
U.S. PATENT DOCUMENTS

4,357,090 A	1/1983	Gray	35096/11	obtaining the requirement of matching elements. In one embodiment a single focusing/defocusing lens is provided substantially in a focal plane of the element having optical power.
4,707,026 A	11/1987	Bauer	3702	
4,839,804 A	6/1989	Schloss	3803	
4,225,410 A	8/1979	Wellmer et al.	3803	
5,341,666 A	5/1994	Avellan et al.	3903/21	
5,414,550 A	5/1995	Pitel et al.	3903/96	
5,472,550 A	12/1995	Riza et al.	3903/35	
5,526,110 A	6/1996	Kent et al.	3903/36	

41 Claims, 12 Drawing Sheets

However, the disclosed device is limited in that the add/drop beams of light are angularly displaced relative to the input/output beams of light. **This angular displacement is disadvantageous** with respect to coupling the add/drop and/or input/output beams of light into parallel optical waveguides, in addition to the additional angular alignment required for the input beam of light.

Bouevitch, 2:1-7; '726 POR, pp. 28-29; '727 POR, pp. 28-29

Boueivitch Discourages Misalignment

US006498872B2

(12) **United States Patent**
Boueivitch et al.

(10) Patent No.: US 6,498,872 B2
(45) Date of Patent: Dec. 24, 2002

(56) OPTICAL CONFIGURATION WITH DYNAMIC GAIN EQUALIZATION AND CONFIGURABLE ADDITIVE MULTIPLEXER

(75) Inventors: Oleg Bouevitch, Thomas Duceille, John Tomlinson, Paul Collinsson, Jacques Bisnaut

(73) Assignee: JDS Uniphase Inc.

(*) Notice: Subject to any disclaimer, this patent is intended to meet the requirements of 35 U.S.C. 154(b) by

(21) Appl. No. 09/719,270
(22) Filed: Dec. 5, 2000
(65) Prior Publication: US 2002/0009257 A1 Jan. 24, 2002

Related U.S. Applications
(60) Provisional application No. 60/200,000

(51) Int. Cl.⁷ G02B 26/08
(52) U.S. Cl. 359/246; 359/247; 359/250

(58) Field of Search 359/115, 122, 125, 124, 130, 131, 245-247, 301-302; 385/16, 18, 24, 31, 37, 39, 47

(56) **References Cited**
U.S. PATENT DOCUMENTS
4,507,089 A 11/1983 Green 260-44
4,707,036 A 11/1987 Binger 350/96,12
4,839,884 A 6/1989 Schloss 370/3
5,233,815 A 8/1993 McManer et al. 266/233
5,341,699 A * 5/1994 Asakawa et al. 399/337,32
5,414,540 A * 5/1995 Patel et al. 369/196
5,477,350 A 12/1995 Riva et al. 359/39
5,526,555 A 6/1996 Kent et al. 399/189

* Cited by examiner.
Cited by applicant. Advantageously, this invention provides a 4x4 system wherein a preferred embodiment the element having optical power is a concave reflector for providing a single means for receiving light from the front-end unit, reflecting the received light to the dispersive element, receiving light from the dispersive element, and providing dispersed light to the modifying means. Conveniently and advantageously, this same concave reflector is utilized on a return path, obviating the requirement of matching elements. In one embodiment a single focussing/collimating lens is provided substantially at a focal plane of the element having optical power.

41 Claims, 12 Drawing Sheets

The lateral displacement of the input and modified output beams of light (i.e., as opposed to angular displacement) allows for highly efficient coupling between a plurality of input/output waveguides.

Boueivitch, 7:60-63; '726 POR, pp. 28-29; '727 POR, pp. 28-29

Bouevitch is Designed to Correct Misalignment

(12) United States Patent
Bouevitch et al.

(11) Patent No.
(15) Date of Pat.

(56) OPTICAL CONFIGURATION FOR A
DYNAMIC GAIN EQUALIZER AND A
CONFIGURABLE ADDRESS/PROP
MULTIPLIER

1,740,238 A 03/99
1,706,271 A 03/99
1,667,831 A 10/99
1,626,284 A 03/99
1,580,118 A 03/99
1,549,752 A 03/99
1,543,158 A 03/99
1,500,143 A 03/99
1,410,003 A 02/99
1,381,431 A 02/00
1,313,155 A 02/00
1,043,946 B1 * 02/00

(73) Invention: Oleg Bouevitch, Ottawa (CA);
Thomas Duestler, Ottawa (CA); W.
John Tomlinson, Princeton, NJ (US);
Paul Colbourne, Napanee (CA);
Jacques Bismuth, Ottawa (CA)

(75) Assignee: JBS Uniphase Inc., Ottawa (CA)

* cited by examiner

(71) Notice: Subject to any disclaimer, the term of this
patent is extended or adjusted under 35
U.S.C. 154(b) by 17 days.

Primary Examiner—Herna
Assistant Examiner—Diana
(34) Attorney, Agent, or Fi

(21) Appl. No. 09/719,270

(57)

(22) Filed: Dec. 5, 2000

(65) Prior Publication Data

US 2002/002257 A1 Jan. 24, 2002

Related U.S. Application Data

(60) Provisional application No. 60/083,151, filed on Feb. 17,
2000.

(51) Int. Cl.⁷ G02B 30/08; H03G 14/02

(52) U.S. Cl. 205/24; 325/37; 359/104;
359/246; 359/247; 359/301; 359/302; 359/328

(58) Field of Search 349/101, 106;
349/115, 124, 128, 129, 130, 131, 145-207;
301-310; 385/16, 38, 24, 31, 37, 39, 47

(56) References Cited

U.S. PATENT DOCUMENTS

4,357,040 A 11/83 Gray 376-44
4,707,036 A 11/87 Bismuth 35/006-12
4,839,804 A 6/89 Schless 37/87
1,232,412 A 8/79 Williams et al. 18/01-21
1,311,646 A * 5/84 Anderson et al. 16/01/21-23
1,414,540 A * 5/89 Patel et al. 34/01/99
1,472,540 A 12/85 Ray et al. 35/01-35
1,526,110 A 6/89 Kay et al. 39/01/28

An optical device for non-signal that is capable of equalizing (OME) and/or a multiplier (OMM) is includes a front-end unit for light, an element having collimating/focusing effect with optical dispersion, a perforated substrate with liquid crystal array for self-purport of a beam of light, an anamorphic wave device as a switching array of a COADM. Advantageous system when a perforated optical power in a common means for assisting light if the received light to the diffractive element the modulating means. On the same occasion, without obtaining the requirement embodiment a single focus substrate by a focal plane power.

41 Claims, 12 Drawing Sheets

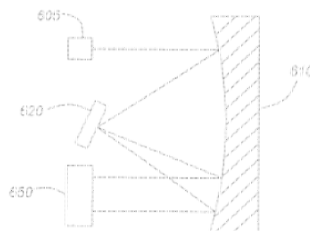

Advantageously, the optical arrangement shown in FIGS. 6a and 6b provides a symmetrical 4-f optical system with fewer alignment problems and less loss than prior art systems. In fact, many of the advantages of this design versus a conventional 4f system using separate lenses is afforded due to the fact that the critical matching of components is obviated. One significant advantage relates to the fact that the angle of incidence on the grating, in the first and second pass, is inherently matched with the optical arrangement.

Bouevitch, 10:62-11:4; '726 POR, p. 24; '727 POR, p. 24

Bouevitch is Designed to Correct Misalignment

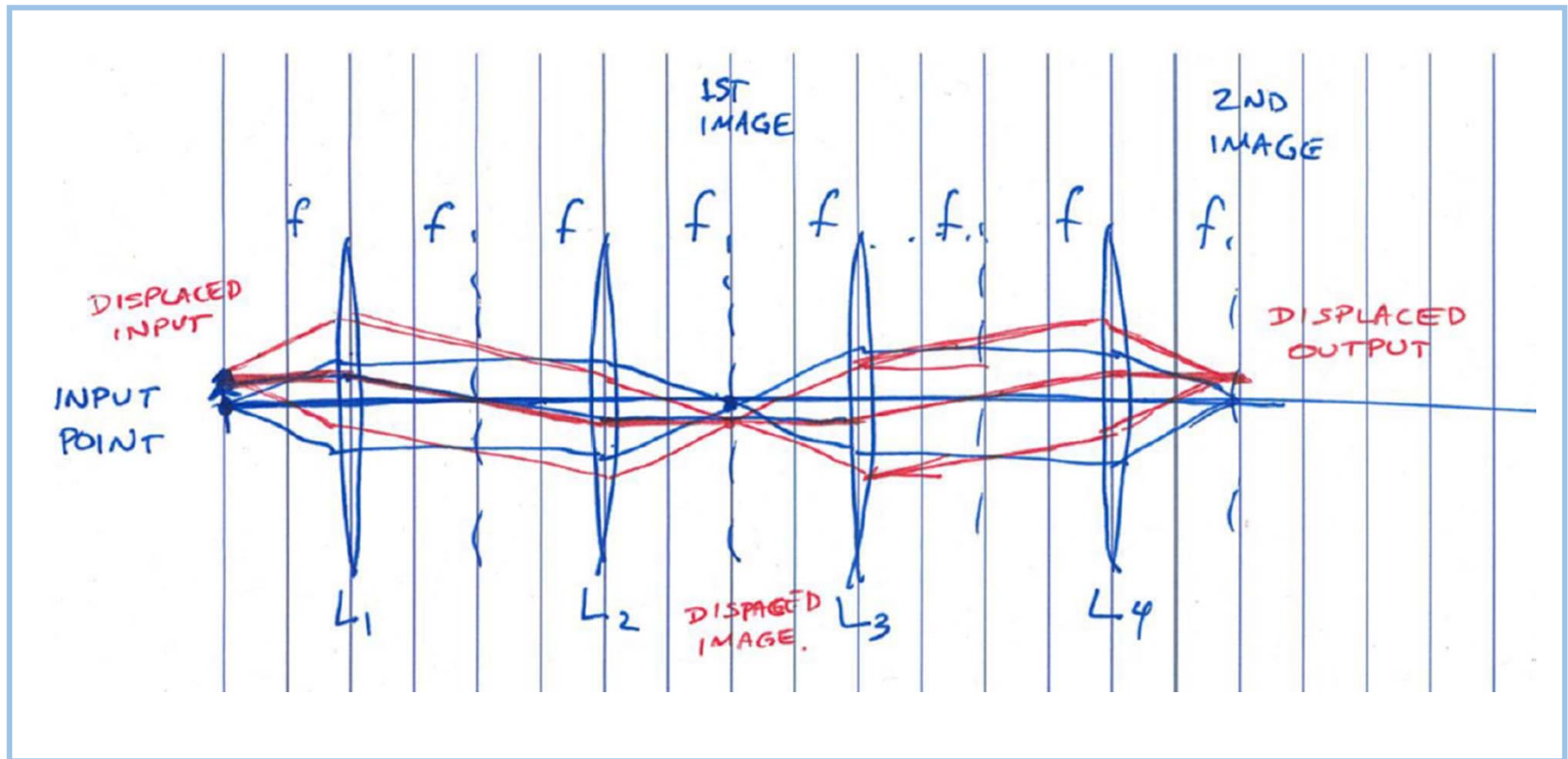

Ex. 2034; '726 POR, p. 25; '727 POR, p. 25

Bouevitch is Designed to Correct Misalignment

Dr. Ford

Page 1

UNITED STATES PATENT AND TRADEMARK OFFICE
BEFORE THE PATENT TRIAL AND APPEAL BOARD

- - -

FUJITSU NETWORK COMMUNICATIONS, INC.

Petitioner

v.

CAPELLA PHOTONICS, INC.

Patent Owner

- - -

Inter Partes Review Case No. IPR2015-00726

Patent No. RE42,368

AND

Inter Partes Review Case No. IPR2015-00727

Patent No. RE42,678

- - -

MILBANK, TWEED, HADLEY & MCCLOY LLP

28 LIBERTY STREET

NEW YORK, NEW YORK 10005

DECEMBER 11, 2015

8:48 A.M.

VIDEOTAPED DEPOSITION OF

JOSEPH E. FORD, PH.D.

REPORTED BY:

DEBRA SAPIO LYONS, RDR, CRR, CCR, CPE

JOB NO. PA 2199236

Q. So just so I understand, so if the fiber were shifted down accidentally for some reason and then it went through the lens, hit the grating, went back to the MEMS, would go through the lens again, hit the grating, but then it would come back to the shifted down part of --

A. Yes.

Q. -- the fiber automatically?

A. Automatically.

Q. So it's a way to automatically make sure that the -- the light gets back into the fiber?

A. That's right.

Ford Depo. Tr., 140:23-141:12; '726 POR, p. 25; '727 POR, p. 25

Changes the Principle of Operation

UNITED STATES PATENT AND TRADEMARK OFFICE

BEFORE THE PATENT TRIAL AND APPEAL BOARD

Dr. Sergienko:

FUJ

127. Bouevitch's self-alignment principle of operation would preclude a person of ordinary skill in the art from making the combination proposed by Fujitsu.

DECLARATION OF DR. ALEXANDER V. SERGIENKO
IN SUPPORT OF THE PATENT OWNER RESPONSE

Sergienko Dec., ¶ 127; '726 POR, p. 26; '726 POR, p. 26

Mail Stop "Patent Board"
Patent Trial and Appeal Board
U.S. Patent and Trademark Office
P.O. Box 1450
Alexandria, VA 22313-1450

Outline

I. Capella Invented a New Class of Optical Switches

II. No Motivation to Combine

- Hindsight
- Changes the Principle of Operation

III. Ports

- Collimator Ports vs. circulators
- Disavowal / Disclaimer
- The '217 Provisional

Collimator Ports vs. circulators

'368 Patent

an input port for an input multi-wavelength optical signal having first spectral channels;
one or more other ports for second spectral channels; an output port for an output multi-wavelength optical signal;

'678 Patent

a) multiple fiber collimators, providing an input port for a multi-wavelength optical signal and a plurality of output ports;

Collimator Ports vs. circulators

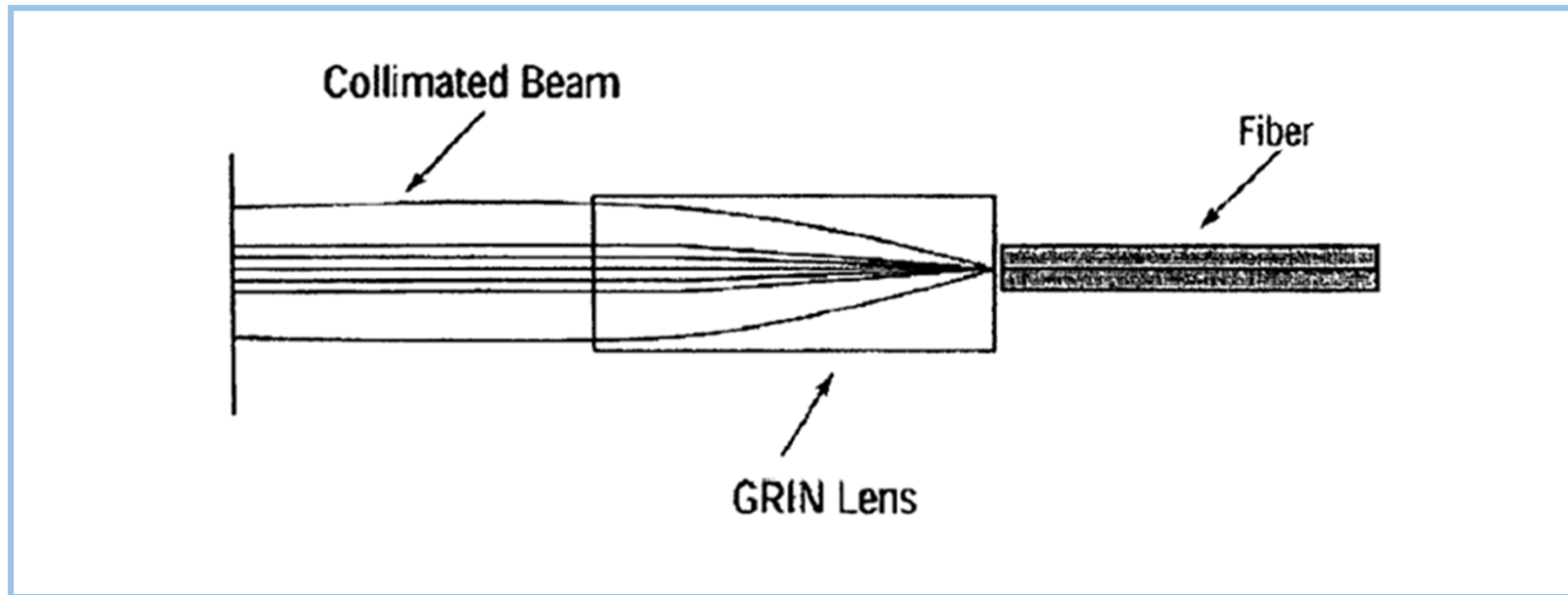

Ex. 1001, FIG. 1D; '726 POR, p. 15; '727 POR, p. 15

Each output port is provided by a quarter-pitch GRIN lens (2 mm in diameter) coupled to an optical fiber (see FIG. 1D).

Ex. 1001, 8:41-43; '726 POR, p. 15; '727 POR, p. 15

Collimator Ports vs. circulators

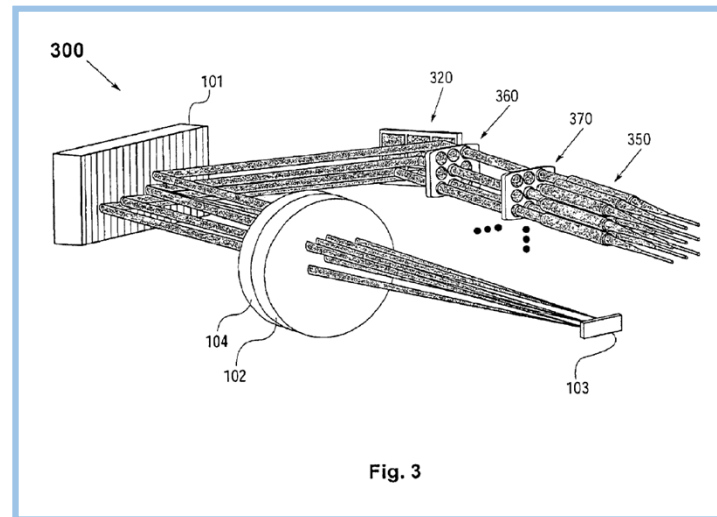
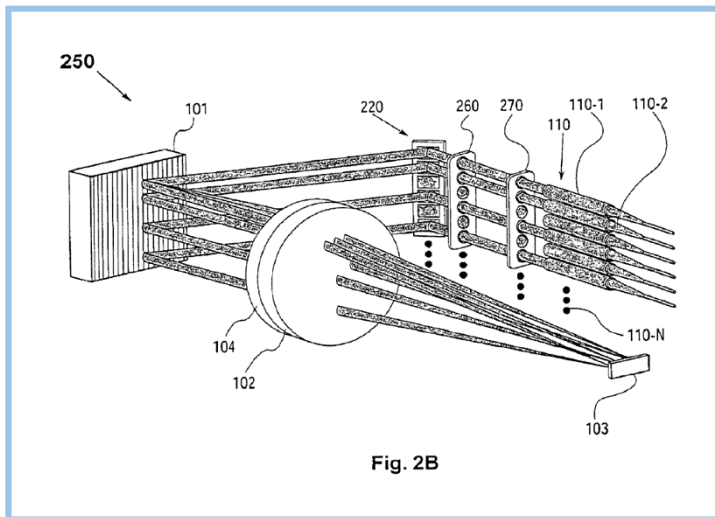
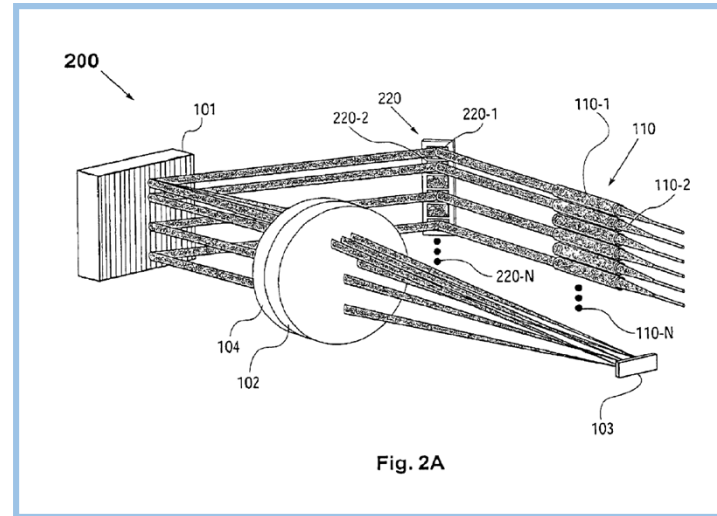
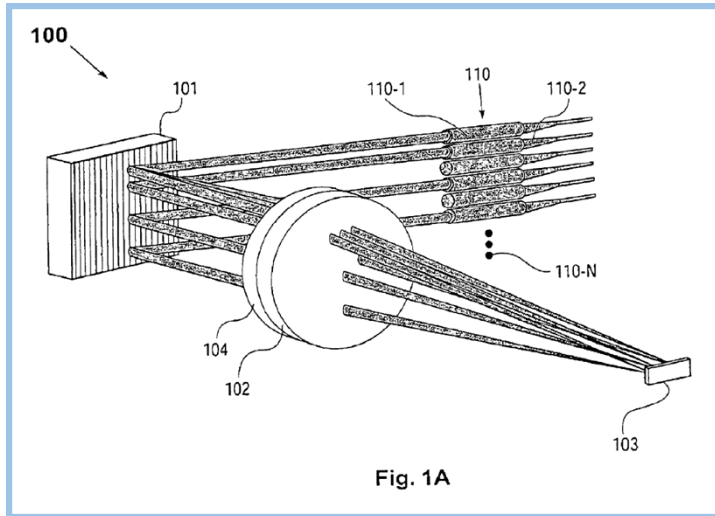

Collimator Ports vs. circulators

Background

Conventional OADMs in the art typically employ multiplexers/demultiplexers (e.g, waveguide grating routers or arrayed-waveguide gratings), tunable filters, optical switches, and optical circulators in a parallel or serial architecture to accomplish the add and drop functions.

Ex. 1001, 1:59-63; '726 POR, p. 39; '727 POR, p. 39

(19) United States
(12) Reissued Patent
Chen et al.



US 6,879,750 B2

(10) Patent Number: US RE42,368 E
(45) Date of Reissued Patent: May 17, 2013

(54) RECONFIGURABLE OPTICAL ADD-DROP MULTIPLEXERS WITH SERIAL AND DYNAMIC SPECTRAL MANAGEMENT CAPABILITY

(56) References Cited

(75) Inventors: Tai Chen, San Jose, CA
Wilde, Morgan Hill, CA
E. Davis, Morgan Hill, CA

(73) Assignee: Capella Photonics, Inc.
(US)

(21) Appl. No. 12/816,084

(22) Filed: Jun. 15, 2010

Related U.S. Patent Documents

Reissue of:

(64) Patent No.: 6,879,750
Issued: Apr. 12, 2005
Appl. No.: 16/745,364
Filed: Dec. 22, 2003

U.S. Applications

(65) Continuation of application No. 1
Nov. 7, 2001, now Pat. No. 6,622,000
continuation of application No. 09/8
Aug. 25, 2001, now Pat. No. 6,622,000

(66) Provisional application No. 60/27
19, 2001.

(51) Int. Cl.
G02B 6/28 (2006.01)
H04J 14/02 (2006.01)

(52) U.S. Cl. 385/24, 385/25

(58) Field of Classification Search 385/24, 385/25, 385/11, 10, 37, 34, 33, 398/79, 82, 83, 84, 398/80, 87

See application file for complete search history.

22 Claims, 12 Drawing Sheets

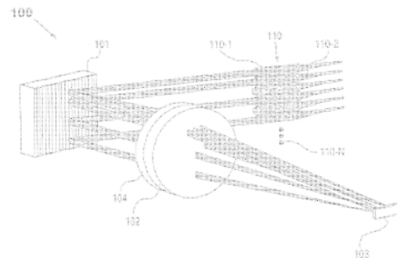

Collimator Ports vs. circulators

Background

An optical circulator therefore has to be implemented, to provide necessary routing of these two signals. Likewise, all the add and drop channels enter and leave the OADM through the same output port, hence the need for another optical circulator. Moreover, additional means must be provided to multiplex the add channels before entering the system and to demultiplex the drop channels after exiting the system. This additional multiplexing/demultiplexing requirement adds more cost and complexity that can restrict the versatility of the OADM thus-constructed. Second, the optical circulators implemented in this OADM for various routing purposes introduce additional optical losses, which can accumulate to a substantial amount.

US09HE4265E

(51) United States
(52) Reissued Patent
Chen et al.

(10) Patent Number: US RE42,368 E
(45) Date of Reissue Patent: May 17, 2011

(56) References Cited

(54) RECONFIGURABLE OPTICAL ADD-DROP MULTIPLEXERS WITH HYBRID CONTROL AND DYNAMIC SPECTRAL POWER MANAGEMENT CAPABILITIES

(75) Inventors: Tai-Chen, San Jose, CA (US); Jeffrey B. White, Morgan Hill, CA (US); Joseph E. Davis, Morgan Hill, CA (US)

(73) Assignee: Capella Photonics, Inc., San Jose, CA (US)

(31) Appl. No.: 12/816,084

(32) Filed: Nov. 15, 2010

Related U.S. Patent Documents

Reissue of:

(64) Patent No.: 6,879,750
Issued: Apr. 12, 2005
Appl. No.: 10/745,364
Filed: Dec. 22, 2003

U.S. Applications:

(63) Continuation of application No. 10/004,714, filed on Dec. 7, 2001, now Pat. No. 6,887,412, which is a continuation of application No. 09/350,206, filed on Aug. 23, 2000, now Pat. No. 6,625,346.

(69) Provisional application No. 60/277,217, filed on Mar. 19, 2001.

(51) Int. Cl. (2006.01) G02B 6/28 (2006.01) H04L 1/00

(52) U.S. Cl. (2006.01) 380/24; 385/10; 345/33; 345/37; 390/33

(58) Field of Classification Search: 345/24; 380/11; 19; 37; 34; 33; 398/79; 82; 83; 84; 398/48; 37

See application file for complete search history.

Ex. 1001, 2:45-57; '726 POR, p. 39; '727 POR, p. 39

Collimator Ports vs. circulators

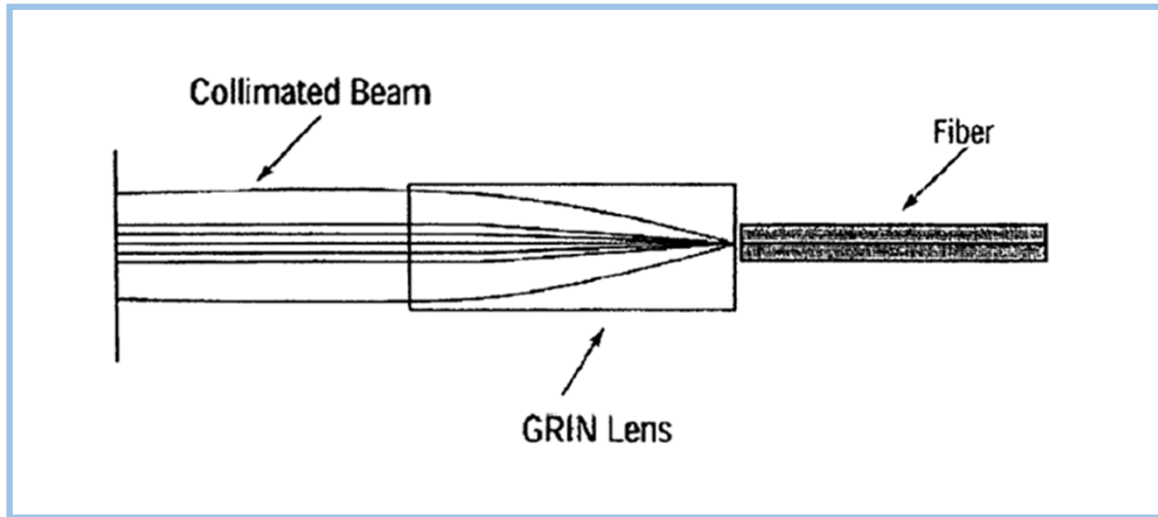

Ex. 1001, FIG. 1D; '726 POR, p. 15; '727 POR, p. 15

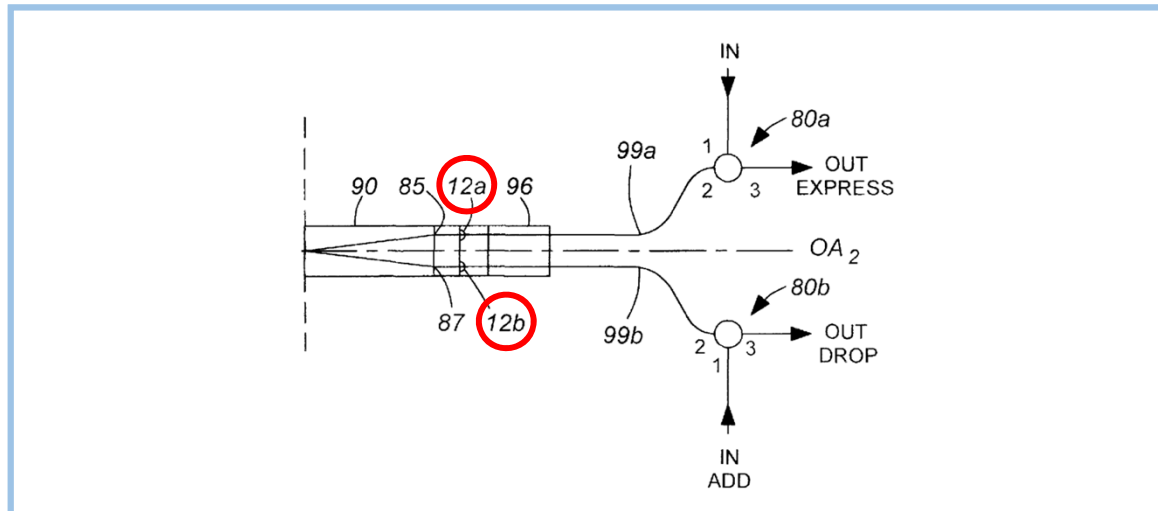

See Bouevitch, FIG. 11; '726 POR, p. 41; '727 POR, p. 41

Outline

I. Capella Invented a New Class of Optical Switches

II. No Motivation to Combine

- Hindsight
- Changes the Principle of Operation

III. Ports

- Collimator Ports vs. circulators
- Disavowal / Disclaimer
- The '217 Provisional

Disavowal / Disclaimer

Legal Requirement

" [The Federal Circuit has] found disavowal or disclaimer based on . . . '***the present invention includes . . .***' or '***the present invention is***'"

Pacing Techs., LLC v. Garmin Int'l, Inc.,
778 F.3d 1021, 1024 (Fed. Cir. 2015)
(internal citations omitted)

Evidence Shows

" ***The present invention provides*** a wavelength-separating-routing (WSR) apparatus and method which employ an array of fiber collimators serving as an input port and a plurality of output ports"

Ex. 1001, 3:54-58 (emphasis added);
'726 POR, p. 39; '727 POR, p. 39

Disavowal / Disclaimer

US 0391412 B2

(39) United States
(32) Reissued Patent
Chen et al.

(54) RECONFIGURABLE OPTICAL ADD-DROP MULTIPLEXERS WITH SERVO CONTROL AND DYNAMIC SPECTRAL POWER MANAGEMENT CAPABILITIES

(75) Inventors: Ird Chen, San Jose, CA (US); Jeffrey White, Morgan Hill, CA (US); Joseph E. Davis, Morgan Hill, CA (US)

(73) Assignee: Capella Photonics, Inc., San Jose, CA (US)

(21) Appl. No.: 12/816,084

(22) Filed: Jun. 15, 2010

Related U.S. Patent Documents

Reissue of:

(64) Patent No.: 6,879,750
Issued: Apr. 12, 2005
Appl. No.: 10/748,364
Filed: Dec. 12, 2003

U.S. Applications:

(73) Continuation of application No. 10/001,714, filed Nov. 7, 2001, now Pat. No. 6,287,471, which is a continuation of application No. 09/538,626, filed Aug. 23, 2000, now Pat. No. 6,635,546.

(66) Provisional application No. 60/277,217, filed on 10/20/01.

(51) Int. Cl.
G02B 6/28 (2006.01)
H04L 14/00 (2006.01)

(52) U.S. Cl. 386/24; 385/10; 345/33; 386/25; 386/26; 386/27; 386/28; 386/29; 386/30; 386/31; 386/32; 386/33; 386/34; 386/35; 386/36; 386/37

Field of Classification Search: 386/24, 386/25, 386/26, 386/27, 386/28, 386/29, 386/30, 386/31, 386/32, 386/33, 386/34, 386/35, 386/36, 386/37

See application file for complete search history.

22 Claims, 12 Drawing Sheets

SUMMARY

The present invention provides a wavelength-separating-routing (WSR) apparatus and method which employ an array of fiber collimators serving as an input port and a plurality of output ports; a wavelength-separator; a beam-focuser; and an array of channel micromirrors.

Ex. 1001, 3:54-58; '726 POR, p. 39; '727 POR, p. 39

Outline

I. Capella Invented a New Class of Optical Switches

II. No Motivation to Combine

- Hindsight
- Changes the Principle of Operation

III. Ports

- Collimator Ports vs. circulators
- Disavowal / Disclaimer
- The '217 Provisional

The '217 Provisional

Dr. Sergienko

176. I understand that Petitioner may allege that the '368 patent's provisional application, included as Exhibit 2012, is inconsistent with the claim construction that the claimed ports are not circulator ports. I would strongly disagree with Petitioner on this point.

'726 Sergienko Dec., ¶ 176; '727 Sergienko Dec., ¶ 176

Dr. Ford

Did Not Consider the '217 Provisional For Claim Construction

'726 Ford Dec., pp. 4-6; '727 Ford Dec., pp. 4-6

The '217 Provisional

CAP-101/PRov 3-21-01

PROVISIONAL APPLICATION FOR PATENT COVER SHEET

INVENTOR(S)

Given Name (Snt and initials if any)	Family Name or Surname	Residence (City and either State or Foreign Country)
Jeffrey P.	Wilde	Los Gatos, CA

Reconfigurable Optical Add-Drop Multiplexer with Dynamic Spectral Equalization Capability for DWDM Optical Networking Applications

Correspondence Address

Customer Number

OR

Applicant

Capella Photonics, Inc.

c/o Jeffrey P. Wilde

19 Great Oaks Blvd., Suite 10

San Jose, CA 95139

USA (408) 360-4240 (408) 220-6048

ENCLOSED APPLICATION PARTS (check all that apply)

Specification Number of Pages 18

Drawings Number of Sheets 22

Application Data Sheet, See 37 CFR 1.76

Method of Payment of Filing Fees for this Provisional Application for Patent

Applied claim small entity status. See 37 CFR 1.27.

A check or money order is enclosed to cover the filing fee.

FILING FEE

AMOUNT (\$)

Bi-Directional OADM Approach (Circulator Scheme)

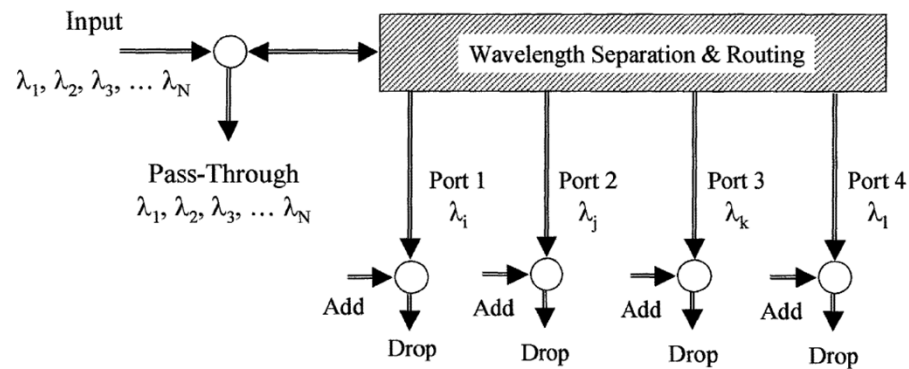

Ex. 2012, FIG. 9; '726 POR, p. 39; '727 POR, p. 39

The third architecture (Fig. 9) is also bi-directional, but uses only one WSR unit. Circulators are situated on all of the physical input/output ports, allowing for two-way optical propagation. This design has the restriction that at each of the add/drop ports, the add and drop wavelengths must be the same.

Ex. 2012, *4; '726 POR, p. 39; '727 POR, p. 39

The '217 Provisional

Bi-Directional OADM Approach (Circulator Scheme)

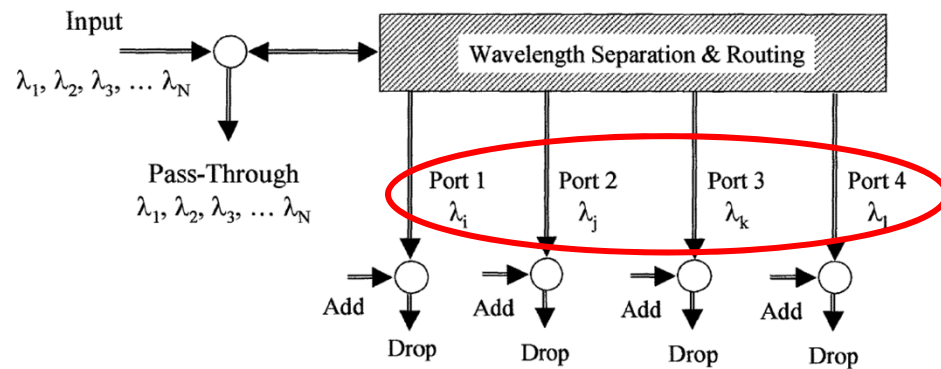

Ex. 2012, FIG. 9; '726 POR, p. 39; '727 POR, p. 39

- **Target Configuration:**
 - 4 to 8 physically separate add/drop ports
 - Each port can add & drop multiple wavelengths
 - Each port requires a circulator to separate the add & drop channels

Ex. 2012, *35; '726 POR, p. 39; '727 POR, p. 39

CAP-101/PRV 3-21-01

Please type a plus sign (+) inside this box

Approved for use through 12/31/2009. OMB 5010-1022
U.S. Patent and Trademark Office, U.S. DEPARTMENT OF COMMERCE

Under the Paperwork Reduction Act of 1995, no person is required to respond to a collection of information unless it displays a valid OMB control number.

PROVISIONAL APPLICATION FOR PATENT COVER SHEET
This is a request for filing a PROVISIONAL APPLICATION FOR PATENT under 37 CFR 1.53(a).

INVENTOR(S)
Given Name (last and middle if any): Jeffrey P. Wildo
Family Name or Surname: Wildo
Residence: Los Gatos, CA

Additional inventors are being named on the _____ separately numbered sheets attached hereto.

TITLE OF THE INVENTION (See instructions page)
Reconfigurable Optical Add-Drop Multiplexer with Dynamic Spectral Equalization Capability for DWDM Optical Networking Applications

Directed correspondence to: CORRESPONDENCE ADDRESS
Customer Number: _____
OR
Firm or Individual Name: Capella Photonics, Inc.
Address: c/o Jeffrey P. Wildo
19 Great Oaks Blvd., Suite 10
City: San Jose State: CA ZIP: 95119
Country: USA Telephone: (408) 380-4240 Fax: (408) 220-0240

ENCLOSED APPLICATION PAPERS (check all that apply)
 Specification Number of Pages: 13
 Drawing(s) Number of Sheets: 22
 Application Data Sheet, See 37 CFR 1.75
 CD(s), Number: _____
 Other (specify): _____

METHOD OF PAYMENT OF FILING FEE FOR THIS PROVISIONAL APPLICATION FOR PATENT
 Applicant claims small entity status. See 37 CFR 1.27. FILING FEE: \$150.00
 A check or money order is enclosed to cover the filing fee. FILING FEE: \$150.00

The Commissioner is hereby authorized to accept any overpayment to be returned by credit card. Form PTO-C-200-101

This invention was made by an agency of the United States Government.

Yes, the name of the U.S. Government agency.

Signature: *Jeffrey P. Wildo*
Typed or Printed Name: Jeffrey P. Wildo
Telephone: (408) 380-4243

USE ONLY FOR FILING
This collection of information is required by a provisional application. Confidentiality is not guaranteed, including gathering, preparing, and disseminating. Any information on this form should be used by the Chief Information Officer. DO NOT SEND FEES OR CHECKS. Commissioner for Patents, Washington, D.C.

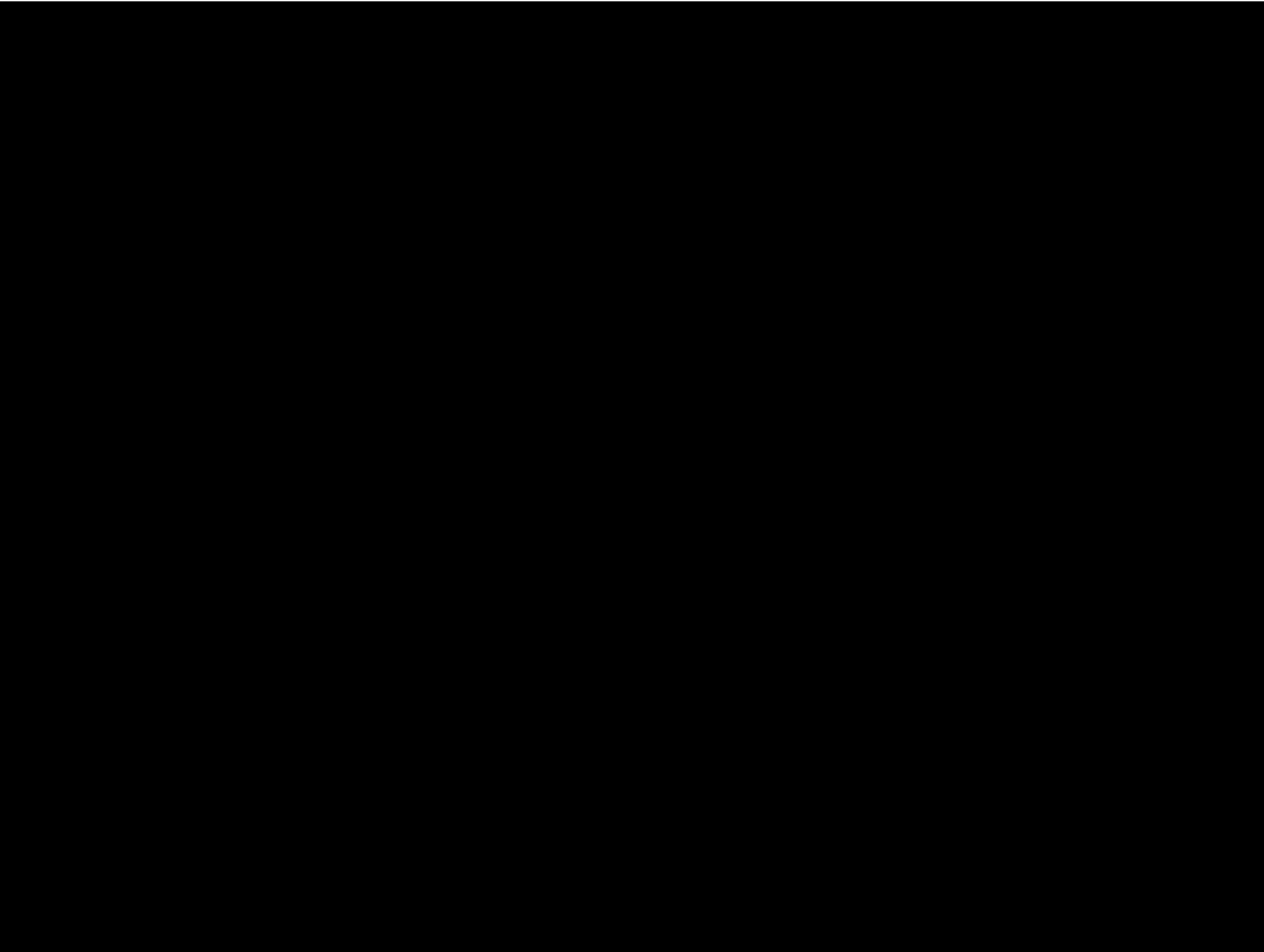

'368 Patent: Claim 1

1. An optical add-drop apparatus comprising
an input port for an input multi-wavelength optical signal
having first spectral channels;
one or more other ports for second spectral channels; an
output port for an output multi-wavelength optical sig-
nal;
a wavelength-selective device for spatially separating said
spectral channels; [and]
a spatial array of beam-deflecting elements positioned such
that each element receives a corresponding one of said
spectral channels, each of said elements being individu-
ally and continuously controllable *in two dimensions* to
reflect its corresponding spectral channel to a selected
one of said ports *and to control the power of the spectral
channel reflected to said selected port.*

'368 Patent: Claim 15

15. An optical add-drop apparatus, comprising
an input port for an input multi-wavelength optical signal
having multiple spectral channels;
an output port for an output multi-wavelength optical signal;
one or more drop ports for selected spectral channels
dropped from said multi-wavelength optical signal;
a wavelength-selective device for spatially separating said
multiple spectral channels; and
a spatial array of beam-deflecting elements positioned such
that each element receives a corresponding one of said
spectral channels, each of said elements being individually
and continuously controllable *in two dimensions* to
reflect its corresponding spectral channel to a selected
one of said ports *and to control the power of the spectral
channel reflected to said selected port*, whereby a subset
of said spectral channels is directed to said drop ports.

'368 Patent: Claim 16

16. An optical add-drop apparatus, comprising
an input port for an input multi-wavelength optical signal
having multiple spectral channels;
an output port for an output multi-wavelength optical signal;
one or more add ports for selected spectral channels to be
added to said output multi-wavelength optical signal;
a wavelength-selective device for reflecting said multiple
and said selected spectral channels; and
a spatial array of beam-deflecting elements positioned such
that each element receives a corresponding one of said
spectral channels, each of said elements being individually
and continuously controllable *in two dimensions* to
reflect its corresponding spectral channel to a selected
one of said ports *and to control the power of the spectral
channel reflected to said selected port*, whereby said
spectral channels from said add ports are selectively
provided to said output port.

'368 Patent: Claim 17

17. A method of performing dynamic add and drop in a WDM optical network, comprising
separating an input multi-wavelength optical signal into spectral channels;
imaging each of said spectral channels onto a corresponding beam-deflecting element; and
controlling dynamically and continuously said beam-deflecting elements *in two dimensions* so as to combine selected ones of said spectral channels into an output multi-wavelength optical signal *and to control the power of the spectral channels combined into said output multi-wavelength optical signal.*

'678 Patent: Claim 1

1. A wavelength-separating-routing apparatus, comprising:
 - a) multiple fiber collimators, providing an input port for a multi-wavelength optical signal and a plurality of output ports;
 - b) a wavelength-separator, for separating said multi-wavelength optical signal from said input port into multiple spectral channels;
 - c) a beam-focuser, for focusing said spectral channels into corresponding spectral spots; and
 - d) a spatial array of channel micromirrors positioned such that each channel micromirror receives one of said spectral channels, said channel micromirrors being **pivotal about two axes and being** individually and continuously controllable to reflect [[said]] **corresponding received** spectral channels into **any** selected ones of said output ports **and to control the power of said received spectral channels coupled into said output ports.**

'678 Patent: Claim 21

21. A servo-based optical apparatus comprising:
- a) multiple fiber collimators, providing an input port for a multi-wavelength optical signal and a plurality of output ports;
 - b) a wavelength-separator, for separating said multi-wavelength optical signal from said input port into multiple spectral channels;
 - c) a beam-focuser, for focusing said spectral channels into corresponding spectral spots; and
 - d) a spatial array of channel micromirrors positioned such that each channel micromirror receives one of said spectral channels, said channel micromirrors being individually controllable to reflect said spectral channels into selected ones of said output ports; and
 - e) a servo-control assembly, in communication with said channel micromirrors and said output ports, for maintaining a predetermined coupling of each reflected spectral channel into one of said output ports.

'678 Patent: Claim 44

44. An optical system comprising a wavelength-separating-routing apparatus, wherein said wavelength-separating-routing apparatus includes:

- a) an array of fiber collimators, providing an input port for a multi-wavelength optical signal and a plurality of output ports including a pass-through port and one or more drop ports;
- b) a wavelength-separator, for separating said multi-wavelength optical signal from said input port into multiple spectral channels;
- c) a beam-focuser, for focusing said spectral channels into corresponding spectral spots; and
- d) a spatial array of channel micromirrors positioned such that each channel micromirror receives one of said spectral channels, said channel micromirrors being **pivotal about two axes and being** individually and continuously **[[pivotal]] controllable** to reflect **[[said]] corresponding received** spectral channels into **any** selected ones of said output ports **and to control the power of said received spectral channels coupled into said output ports**, whereby said pass-through port receives a subset of said spectral channels.

'678 Patent: Claim 61

61. A method of performing dynamic wavelength separating and routing, comprising:

- a) receiving a multi-wavelength optical signal from an input port;
- b) separating said multi-wavelength optical signal into multiple spectral channels;
- c) focusing said spectral channels onto a spatial array of corresponding beam-deflecting elements, whereby each beam-deflecting element receives one of said spectral channels; and
- d) dynamically and continuously controlling said beam-deflecting elements **[[, thereby directing]] in two dimensions to direct** said spectral channels into **[[a plurality]] any selected ones of said output ports and to control the power of the spectral channels coupled into said selected output ports.**

Bouevitch, Figure 11

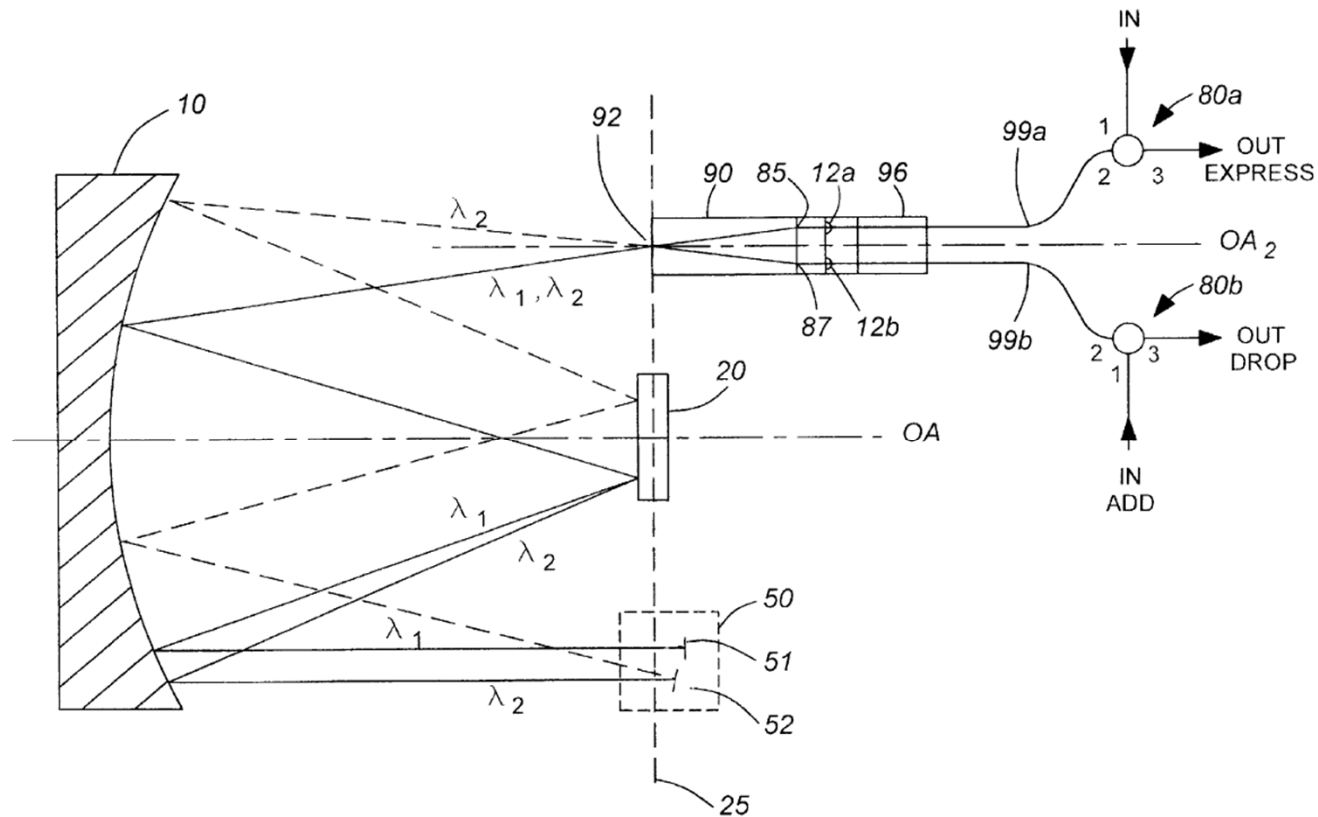

FIG. 11

Bouevitch, FIG. 11; '726 POR, p. 12; '727 POR, p. 12