

09-25-00

A/PROV.

PROVISIONAL APPLICATION COVER SHEET

This is a request for filing a PROVISIONAL APPLICATION under 37 CFR 1.53(c).

09/22/00
1c922 U.S. PTO

1c922 U.S. PTO
60/234683
09/22/00

		Docket Number 206692	Type a plus sign (+) inside this box → +
INVENTOR(S)/APPLICANTS(S)			
LAST NAME	FIRST NAME	MIDDLE INITIAL	RESIDENCE (CITY AND EITHER STATE OR FOREIGN COUNTRY)
SMITH GOLUB FARHAN	David John Fariborz	E.	Norcross, Georgia Norcross, Georgia Norcross, Georgia
TITLE OF THE INVENTION (280 characters max)			
VARIABLE TRANSMISSION MULTI-WAVELENGTH OPTICAL SWITCH			
CORRESPONDENCE ADDRESS			
<input checked="" type="checkbox"/> Customer Number 23460  23460 <small>PATENT TRADEMARK OFFICE</small>		<input type="checkbox"/> Leydig, Voit & Mayer, Ltd. Two Prudential Plaza, Suite 4900 180 North Stetson Chicago, Illinois 60601-6780 U.S.A.	
ENCLOSED APPLICATION PARTS (check all that apply)			
<input checked="" type="checkbox"/> Specification (including any claims and abstract)		Number of Pages: 12	<input type="checkbox"/> Power of Attorney <input type="checkbox"/> Assignment <input type="checkbox"/> Small Entity Status
<input checked="" type="checkbox"/> Drawings		Number of Sheets: 11	<input type="checkbox"/> Other (specify)
METHOD OF PAYMENT (check one)			
<input type="checkbox"/> A check is enclosed to cover the Provisional filing fee of \$150.00. <input checked="" type="checkbox"/> The Assistant Commissioner is hereby authorized to charge the filing fee of \$150.00 to Deposit Account Number 12-1216. <input checked="" type="checkbox"/> The Assistant Commissioner is hereby authorized to charge any fee deficiency or credit any refund to Deposit Account Number 12-1216. A duplicate copy of this communication is enclosed for that purpose.			

The invention was made by an agency of the United States Government or under a contract with an agency of the United States Government:

- No.
- Yes, the name of the U.S. Government agency and the Government contract number are:

Respectfully submitted,

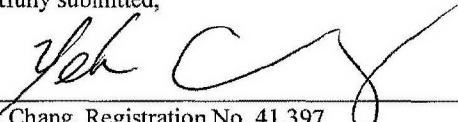

Y. Kurt Chang, Registration No. 41,397
 One of the Attorneys for Applicant(s)
 LEYDIG, VOIT & MAYER, LTD.
 Two Prudential Plaza, Suite 4900
 180 North Stetson
 Chicago, Illinois 60601-6780
 (312) 616-5600 (telephone)
 (312) 616-5700 (facsimile)

Additional inventors are being named on separately numbered sheets attached hereto.

CERTIFICATION UNDER 37 CFR 1.10

I hereby certify that this correspondence and the documents referred to as attached or enclosed therein are being deposited with the United States Postal Service on September 22, 2000, in an envelope as "EXPRESS MAIL POST OFFICE TO ADDRESSEE" service under 37 CFR 1.10, Mailing Label Number EL64353582US, addressed to Commissioner of Patents and Trademarks, Washington, D.C. 20231.

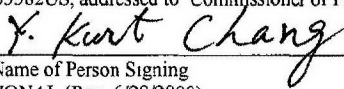
 Printed Name of Person Signing
 PROVISIONAL (Rev 6/29/2000)

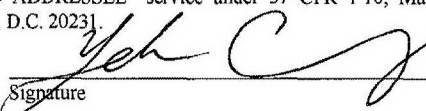
 Signature

Variable Transmission Multi-wavelength Optical Switch

Inventors: Dave Smith, John E. Golub; Fariborz Farhan

Assigned to: MOVAZ Networks, Inc.

5445 Triangle Parkway

Norcross, GA 30092

Background of the Invention

In response to the need for increased communications bandwidth, optical fiber systems operating at wavelengths near 1.5 μm are rapidly replacing conventional copper-conductor electronic systems. Advantages of lightwave technology include increased signal bandwidth (10 GHz rates and higher are possible along a single fiber optic channel), immunity to electrical interference and the possibility of system expansion through wavelength division multiplexing (WDM) which superimposes more than one optical carrier on a single fiber channel.

In a conventional, point-to-point, single-channel system, an electrical input signal modulates the output of a semiconductor laser. The resulting lightwave signal is coupled into a single-mode optical fiber that transports it to an optical receiver. En route, one or more optically-pumped, Erbium-doped fiber amplifiers (EDFA's) or other in-line optical amplifiers may be used to compensate for fiber absorption and other losses. Fiber optical components are used for various functions such as traffic distribution and signal routing. Finally, at the receiver, the beam exiting the fiber is focused onto a detector that converts the lightwave signal to an electronic version of the transmitter input signal.

Multiple information signals may also be combined on a single fiber using wavelength division multiplexing (WDM). In this scheme, individual transmitters operate at a different, fixed wavelengths and signals are combined using all-optical multiplexers that couple the light from several input ports into a single output fiber. At the receiver, an optical wavelength separator spatially separates the individual, single-wavelength channels. Various means of multiplexing and demultiplexing multiple optical carriers on a single fiber are disclosed in ---

review paper on WDM technology. Dedicated detectors are then used to convert the information on each channel to an electronic format.

WDM systems offer wide bandwidth capabilities and the possibilities of upgrading system capacity without changing the installed fiber base. At the present time, commercially-available systems can support 40, 2.5GHz channels yielding a total bandwidth of 100 GHz. The optical system components (fibers, amplifiers, lasers and detectors) can support a much larger bandwidth by far and it is expected that future systems will operate at higher data rates (40 GHz, for example) and include 80 or more WDM channels.

Components required for the realization of a multi-wavelength optical network include simple wavelength multiplexers (MUX) and wavelength demultiplexers (DEMUX), add/drop multiplexers (ADM's), optical cross connect switches (OXC's), in-line optical amplifiers and associated gain control technologies, optical performance monitors and wavelength channel power equalizers. Wavelength conversion is another area of active development.

Present-day optical WDM networks are based on components that often disadvantageously utilize the optical-to-electronic-to-optical conversion process for signal regeneration, switching, power equalization and other network functions. System bandwidth and particularly, system upgradability is constrained by the complexity and cost of this pervasive electrical-to-optical conversion requirement. Transparent, all-optical components would effectively address this limitation, facilitating the design of networks in which the optical signal leaving a transmitter would not be converted to the electrical domain until it reached a receiver. A feature of the disclosed invention is that it provides an optically transparent solution to the system requirement for wavelength channel power equalization.

Various WDM components are described in the following as a means of introduction. Wavelength MUX's are used to combine the output beams from a number of single frequency transmitters into a single, wavelength-division-multiplexed signal. DEMUX's perform the inverse function at the receiving stations, physically separating a WDM signal into single frequency beams. Both MUX and DEMUX units may conventionally use fiber or integrated optical components in order to isolate individual WDM channels. A variety of multiplexing techniques using variously, all-fiber components, integrated optical circuits, thin films and diffraction gratings have been developed.

In a typical fiber-optic network application, optical signals occupy a plurality of fiber lines and must be interconnected for signal distribution, multiplexing and demultiplexing of signals from numerous locations, protection routing and other functions. Such coupling and switching of signals amongst fibers is realized by optical switches or crossconnects. Optical cross connect switches (OXC's) provide optical connections between input and output ports that may be reconfigured in response to control signals. In WDM applications, OXC's may be used to connect individual wavelength channels from a single input port to different output ports. If the optical crossconnect further distinguishes among wavelength channels so as to allow redistribution of wavelength content among fibers in a network, this more specific crossconnect is called a wavelength crossconnect.

A variety of crossconnects have been disclosed using a number of different optical technologies. Cross connect designs include devices based on optical interferometry (Mach-Zehnder and directional coupler switch arrays, SOA-based switches, AO, EO and liquid crystal switches, thermo-optical (silica-on-silicon) and polymer optical waveguide switches and optomechanical switches including those based on MEMS (micro-electro-mechanical systems).

US Patent #6,097,859 to Solgaard (*Solgaard*), et.al. discloses a multiwavelength cross-connect switch based on an array of MEMS mirrors. In this device, optical WDM signals are received by a plurality of input ports. An input lens system collimates these beams and directs them to a diffraction grating that reflects different wavelength channels at different angles while preserving the spatial separation of the individual input ports. The resulting two-dimensional array of beams (the width equals number of input beams and the height equals the number of wavelength channels) is imaged onto an array of electronically-actuated micro-mirrors (MEMS array). Each beam is reflected by an individual micro-mirror at an angle that is a function of the applied voltage.

In a first embodiment of Solgaard's patent, the electronically-controlled elements of a second micro-mirror array redirect the beams from the first MEMS device to an output optical system. Single-wavelength beams are reflected by the second array and recombined into WDM outputs signals by a second grating. Optical lenses on either side of the grating collimate the beams from the MEMS array and couple the WDM beams to the output ports of the switch. According to *Solgaard* the output optical system may be a mirror-image of the input system. By adjusting the voltage on the two MEMS arrays, a variable connection between input and output

ports may be established for each wavelength channel in the system. These connections are, however, subject to the constraint that no two inputs in a single wavelength channel may be connected to a single output.

In alternative embodiments, a planar fold mirror is used to eliminate the second MEMS array and output optical system. A fold mirror can be used to reduce the lens and diffraction grating component count and to make a more compact geometry. In this case, for an $N \times N$ fiber wavelength crossconnect, $2N \times W$ mirrors are required, where W is the number of wavelength channels being switched.

Optical add/drop multiplexers (OADM's) allow selected wavelength channels to be added or dropped from a WDM lightwave signal. In its simplest embodiment, an OADM has 4 ports - 'input', 'output', 'add' and 'drop'. Typically, an optical trunk line enters the switch via the 'input' port and exits at the 'output'. Individual wavelength channels may be switched from the 'input' to the 'drop' port or from the 'add' port to the 'output'. Connectivity may or may not be provided between the 'add' and 'drop' ports. Note that the OADM is an application-specific example of a general 2×2 fiber-optic wavelength switch, which is the lowest reasonable port-count wavelength crossconnect (WXC). Larger port-count WXC's allow one of several add inputs to be switched to the output while the input signal is connected to one of several drop ports.

US Patent 5,960,133 to Tomlinson (*Tomlinson*) discloses a MEMS-based ADM switch that also uses a grating to separate the inputs into spatially-distinct, single wavelength beams. In contrast to the Solgaard switch, however, in Tomlinson the beams are switched by a single reflection from a MEMS array.

The overall WDM network performance is optimized when the power on individual wavelength channels is uniform across the channel spectrum. Factors contributing to the inequality of WDM channel powers include source power nonuniformity, different path routing of the channels which comprise the WDM spectrum, differential wavelength-channel gain in optical amplifiers, wavelength-dependent loss along the fiber path and within the components which comprise the overall network.

Generally, the lowest channel power determines the system performance in terms of crosstalk and signal-to-noise ratio, so it is necessary to adapt the system to accommodate the weakest channel. The preferred method is to equalize channel powers to that lowest channel power level.

Thus, it is advantageous to actively compensate for the effects of wavelength-dependent amplifier gain in optical amplifiers and wavelength-dependent transmission loss in a WDM system. Typically, fiber amplifiers are themselves optimized for uniform gain across the WDM spectrum (reference). Conventionally, optical power equalization may be accomplished by sensing the power of each wavelength channel and adjusting the power to the appropriate transmitter. Realization of this scheme is complicated by the fact that transmitters and power measurement instruments are often separated by large distances - a situation that makes the associated electronic power control system both complex and expensive. Therefore, it is preferred to locally resolve the power inequalities at the OXC level, which also prevents propagation of channel power inequities across the network. Propagation of power transients can have an extremely deleterious effect of WDM system performance (reference).

A self-contained unit consisting of an optical performance monitor (OPM), control electronics and a multi-wavelength optical loss modulator may also be used for WDM power equalization. References to an OPM and power equalization schemes. In operation, the OPM measures the power in each WDM channel and transmits this information to a control processor. The processor then adjusts the wavelength-dependent transmission of the modulator to flatten the power distribution curve. While eliminating the need for a distributed control system, this system requires an additional optical component (the loss modulator) to be added to the optical network.

A multi-wavelength OXC or ADM with electronically variable transmission functions for each wavelength channel would eliminate the need for a dedicated optical loss modulator in a self-contained power equalizer. To our knowledge, variable-transmission optical switching components are unknown in the prior art. It is, therefore, a primary object of this invention to provide improved, multi-wavelength, OXC and ADM switches with electronically-controllable transmission.

Brief Description of the Invention

Electronic control of the optical transmission of individual wavelength channels in a multi-wavelength, MEMS optical switch is achieved by intentionally spoiling the spatial mode match between the free-space beams inside the switch and the output optical coupler. This technique may be applied to any optical switch regardless of the number of inputs, wavelength channels, or

the specific switching scheme employed. The invention is further not to be construed as restricted to those switches containing a MEMS optical beam switching methodology.

According to a preferred embodiment of the invention, the optical throughput of each wavelength channel may be controlled by using a mirror array with elements that can be rotated in an analog fashion about two orthogonal axes. Angular displacement in a first, switching plane, is used to perform an OXC, ADM or other switching function while angular displacement about the orthogonal axis is used for power control. MEMS switches with single axis mirror arrays may also be used for output power control. In this case, the coupling of each beam to a designated output port is adjusted by variations in the switching angle.

A complete power equalization system incorporating a variable-transmission MEMS switch is also disclosed. In this system, an optical performance monitor measures the power spectra at the switch output ports and transfers the data to a control processor. This unit generates electronic signals that adjust the angles of individual micro-mirrors within the switch to optimize the output power spectra.

Brief Description of the Figures

Figure 1 is an optical schematic diagram of a 2x2 ADM with variable transmission according to the invention

Figure 2 is a diagram detailing the switching function of the ADM

Figure 3 is a diagram detailing optical power control operation of the ADM.

Figure 4 is a power equalizing ADM system incorporating the switch of Figure 1.

Figure 5 is a figure showing optical crossconnect components in their various roles in a transparent WDM network including multi-fiber wavelength crossconnects (top left), optical add-drop multiplexers, a multiple-LAN distribution network (lower left), a local access wavelength OADM node.

Figure 6 is another view of the OADM 3-space cross connect design including a fold mirror.

Figure 7 shows the mirror tuning scheme used for switching and equalization on orthogonal directions, based on calculations for the design of figures 8 and 9.

Figure 8 is the package of one design of a crossconnect showing dimensions.

Figure 9 is a to-scale figure of the crossconnect of figure 8, with the fold mirror out of plane and separated by 10 mm.

Figure 10 is a schematic of the power equalization scheme described in this invention, applied to the specific case of a folded-mirror multiwavelength crossconnect.

Figure 11 shows electronics circuitry which is appropriate to the drive of the MEMS mirrors for the purposes of power equalization.

Description of the Preferred Embodiments

Referring to Figure 1, a 2x2 multi-wavelength, add-drop multiplexer (ADM) 100 embodying the features of the invention is schematically shown. (100 is not shown in the figure – DS) Optical fibers 105 connect the four ports of the switch to an optical network. Signals may enter the switch through the input port 110 or add port 114 and exit through the drop port 116 and/or output port 112. All fiber channels are wavelength division multiplexed with 8 wavelength channels in the 1.5 μm communications band that are separated by a wavelength increment, $\Delta\lambda$, suitable to WDM communication systems, referring to approximately 0.4 and 0.8 nm respectively, more specifically 50-100 GHz apart in frequency for dense WDM systems.

In a typical application the ADM 100 is used to add or subtract individual wavelength channels from a signal that enters through the input port 110 and exits through the output port 112. Under the control of an external control signal, the ADM may allow a wavelength channel to pass through the switch from input to output or, alternatively, to route the input signal to the drop port and simultaneously connect the add port to the output.

In Figure 1, signals entering the switch 100 are coupled into an optical concentrator 120 that decreases the physical spacing between the input and output channels. (This is the subject of another invention – how should I handle that - DS?) Typical single mode fibers have a diameter of 125 μm and the I/O ports must be spaced at least this far apart. The concentrator of another invention of some of the authors typically uses integrated waveguides to reduce this spacing to approximately 30 μm at the output surface. (Should my and John's notes be incorporated into the invention disclosure as an appendix – DS) The optical lens 125 collects the beams exiting the concentrator, collimating them nominally into a single beam that is reflected by the diffraction grating 130. This grating is oriented with its grooves parallel to the page of the figure and the individual wavelength channels are dispersed into a fan of beams in the direction perpendicular to the page. The lens 135 focuses the light from the diffraction grating to form two, 8-element columns of beams that are reflected by the input and add columns of the micro-mirror array 140

onto the fold mirror 145. Each array column has 8 -elements, corresponding to the 8 wavelength channels in the input and add beams. The spacing between the lens 135 and fold mirror 145 is adjusted to locate the Gaussian waists of the input and add beams at the mirror surface. (Why are we restricting ourselves to folded systems?) - DS

The fold mirror reflects the individual beams back to the MEMS array where they are reflected by the micromirrors in the 8-element output and drop columns. These beams are then collimated by the lens 135, remultiplexed by the grating 130 and focused onto drop and output channels of the optical concentrator 120 by the lens 125, according to the individual control signals applied to determine the switch states independently for each wavelength channel..

Switching of the input and add beams in an individual wavelength channel is accomplished by adjusting the angle of two mirrors in the MEMS array. Two states are possible - a first state in which an input channel is coupled through the switch to the output and a second state in which an input channel is coupled to the drop port and an add channel is coupled to the output.

Figure 2 is a detailed diagram of the beams in a single wavelength channel as they are reflected by the micromirror array 160 and fold mirror 165. The input beams are far enough from the focusing lens to be spatially distinct as they enter the figure. The elements of the micromirror array are adjusted to couple light from the input beam 150 to the oppositely-directed drop beam 154 and the add beam 156 to the output 152.

The input beam 150 travels from the input micromirror 172 to the fold mirror and returns to the drop micromirror 176. The angles of the two elements of the micromirror array are electronically adjusted so that the drop beam propagates in essentially the opposite direction from the input. The optical path lengths between the focusing lens and fold mirror are adjusted to focus the input beam on the fold mirror, i.e. the beam waist is in the plane of the mirror. Similarly, the add beam 156 is directed by the micromirror 174 to the fold mirror in such a way that it is reflected to the micromirror 178 that couples it to the output port. The waist of this beam is similarly located in the plane of the fold mirror.

Advantageously, the micromirror array and fold mirror are separated by a distance that is equal to the Raleigh range of the input and add beams. The Raleigh range is defined as the distance from the Gaussian beam waist after which the beam diameter has increased in size by a factor of root 2. It is equal to $\pi\omega^2/\lambda$. This condition minimizes the ratio of spot size to beam separation at the micromirror plane, minimizing the cross-talk between beams and losses due to

leakage around the mirror edges. This invention does not require that the separations between the micromirror array and the fold mirror is equal to the Raleigh range, only that that separation is a preferred maximum.

In order to control the power of the beams leaving the switch via the output and drop ports, the corresponding micro-mirror elements are designed to tilt about a second, perpendicular axis in the plane of the array. Tilting a pair of elements about this axis translates the corresponding beam on the surface of the optical concentrator, thereby decreasing the percentage of the light coupled out of the switch. By displacing the optical beam perpendicular to the line defining the optical ports, power coupling is decreased in either direction while not sacrificing the degree of isolation between optical channels. That is why it is preferred that the misalignment is orthogonal to the optical access line. One can misalign within the access line, but that misalignment will typically increase coupling into other ports which is negligible up to a point but deleterious thereafter.

Figure 3 is a schematic diagram illustrating this process. In the Figure, the micro-mirror array 200 has four columns corresponding to the four I/O ports and 8 rows corresponding to the individual wavelength channels in an 8-wavelength WDM system. As an example, we consider the switching a single wavelength input beam 205 to a drop beam 210. Not shown in the figure is the add beam that would be switched to the output port in the preferred embodiment.

To switch the input beam, the micro-mirror in the 'i' column of the array 220 is tilted about a first, vertical axis to steer the reflected beam towards the drop output. After reflection by the fold mirror 215, the beam strikes a second, 'd' element 225 of the array. The vertical-axis tilt of this element is adjusted to efficiently couple the beam leaving the array to the drop channel 230 of the optical concentrator 235. In the demonstrated embodiment, an angular displacement of 3.25 degrees is required.

In the example of Figure 3, the percentage of the drop beam that is coupled into the power drop channel 230 of the optical concentrator 235 may be varied by tilting the individual array elements about their horizontal or vertical axes. In normal 'drop' operation, one would adjust the angle of the 'i' mirror element 220, primarily in the horizontal direction to optimize placement of the input beam on the drop mirror element 225. The angle of the 'd' element is then adjusted to align the beam waist with the output plane of the concentrator. In this way, the vertical displacement introduced by the 'i' element repositions the waist at the concentrator in a

predictable and controllable manner. Displacement of the beam from a condition of perfect alignment decreases the percentage of light coupled into the concentrator's drop channel, reducing the amount of power leaving the switch. In the preferred operation of the switch, optimal alignment will be performed by optimal positioning of the beam on the appropriate concentrator element, specifically by controlling the horizontal alignment. Vertical misalignment is the preferred method of reducing power coupling to the chosen output channel. As an example, for singlemode fiber cores illuminated by 1.5 micron light, misalignment in any direction away from the fiber core by one micron results in about 1 dB of attenuation, and further misalignment further exacerbates this coupling degradation in a dramatic manner well known to those skilled in the art. Angular displacement off the waveguide axis is another, less preferred means of reducing coupling.

In other embodiments of the invention, 2-axis MEMS arrays may be used to control the output of prior art switches. For example, they may be used to add output power control capability to the prior art designs disclosed in *Tomlinson* and *Solgaard*. A 3x3 (that is, 3 input port by 3 output port) power-controlled OXC switch with N wavelength channels may also be constructed using 6 x N two-axis mirror array and a switching scheme similar to that of Figure 2. Physically, the number of input/output ports is limited by the maximum tilt angle of a single array element. Devices having many elements may be constructed using conventional technology. The number of wavelength channels is limited by IC fabrication technology and may exceed 100.

Fabrication of silicon MEMS arrays that can be tilted about two orthogonal axes is described in the prior art (see, for example, "Development of a silicon 2-axis micro-mirror for optical cross-connect" by Andrew S. Dewa, and John W. Orcutt published on pp. 93-96 of the Technical Digest of the Solid State Sensor and Actuator Workshop, Hilton Head Island, SC, June 4-8, 2000). In an exemplified embodiment of Figures 1,2 and 3, a 4 x 8 array of 400 μm x 400 μm mirrors with a center spacing of 495 μm in the wavelength direction and 595 μm in the orthogonal, switching direction may be used. In the design of the attached figures showing a particular embodiment of a crossconnect, power variations of 10 dB should be able to be achieved with a 0.3 degree tilt about the orthogonal direction.

Figure 4 is a schematic block diagram of a complete power-controlled switching system incorporating the preferred embodiment of Figure 1. 8-channel, WDM signals are transported to

the ADM switch 305 by single-mode optical fibers 310 (Note – we do not have to restrict ourselves to singlemode), entering through the input port 312 and add port 314. Signals in each wavelength channel are routed to the output 316 and drop 318 ports under the control of the electronic switching input signal 320. Optical fibers 323 are used to transport the WDM signals from the switch to other network components and to taps 325 that direct a small portion of the output signals to an optical performance monitor (OPM) 327. This unit measures the power in the individual wavelength channels of the 'output' and 'drop' signals and transmits the resulting spectral data to the control processor 330. This processor compares the power spectra to optimal distribution functions and generates power control signals to correct the deviations. These signals are transported to the ADM switch on the power control signal line 335 which controls the tilt angle of the individual MEMS elements about the power control axis. This resulting feedback loop may be used to actively optimize the power spectra of the signals leaving the ADM switch. Note – optimizing the output powers should be construed generally. As a rule, one would prefer to maximize the power on each channel, but, for reasons of system uniformity, it is preferred to equalize the powers of all channels which are within a specified range of power (some too-low or too-high power signals may need correction outside the proposed means – e.g. dead lasers) which means adjusting all channel powers until they equal the weakest acceptable channel power – this is common in the current art. For other system reasons, exact equalization may not be preferred, but the current invention is capable of providing programmable power control to adapt to all system requirements. In an alternate embodiment of the power equalization system, the wavelength-dependent transmission of optical switches incorporating single-axis MEMS arrays may be varied by adding the control processor output to the switching signal. In this case, the optical coupling between the free space beam inside the switch and the output port is adjusted by translating the beam in the switching plane. In comparison to the two-axis embodiment, single axis systems may be realized using simpler, single axis MEMS arrays but suffer from increased potential for crosstalk between channels.

The invention is embodied by any multi-wavelength MEMS optical switch that uses the tilt angle of individual micro-mirrors to provide independent control of the transmission of each wavelength channel. Both single and dual axis mirror arrays may be used in a variety of switching configurations, although the two-axis components are preferred. Switching schemes include, but are not limited to, those described in *Tomlinson* and *Solgaard* in addition to the

preferred scheme described above. More generally, the invention discloses the use of controlled misalignment in fiber optical devices in order to introduce a controlled loss for the purposes of enabling power equalization. This is not restricted to WDM systems. It is further not restricted to matching power levels of optical channels but for achieving any desired channel power profile according to network management needs.

Variable Transmission Switch

Figure 1

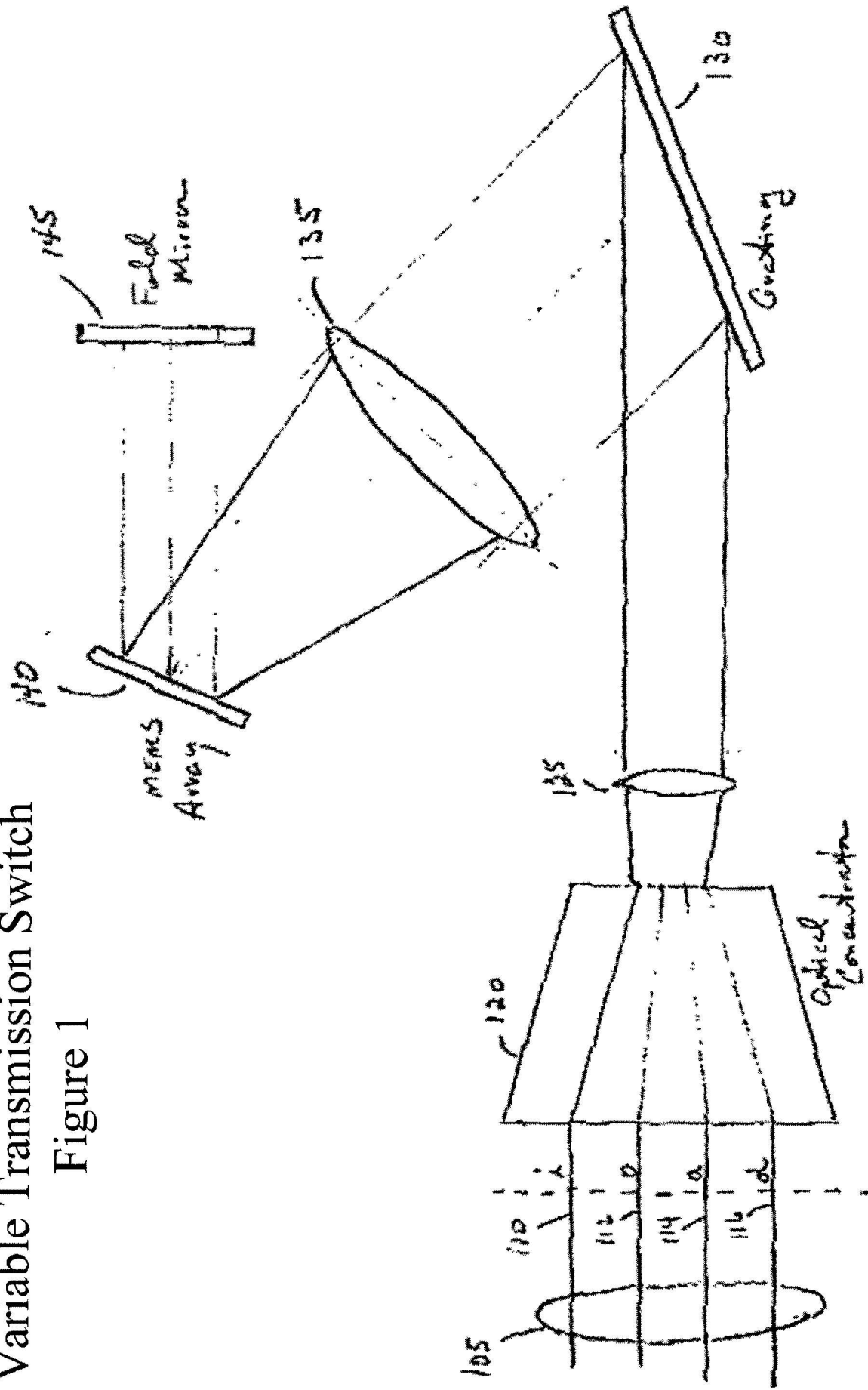

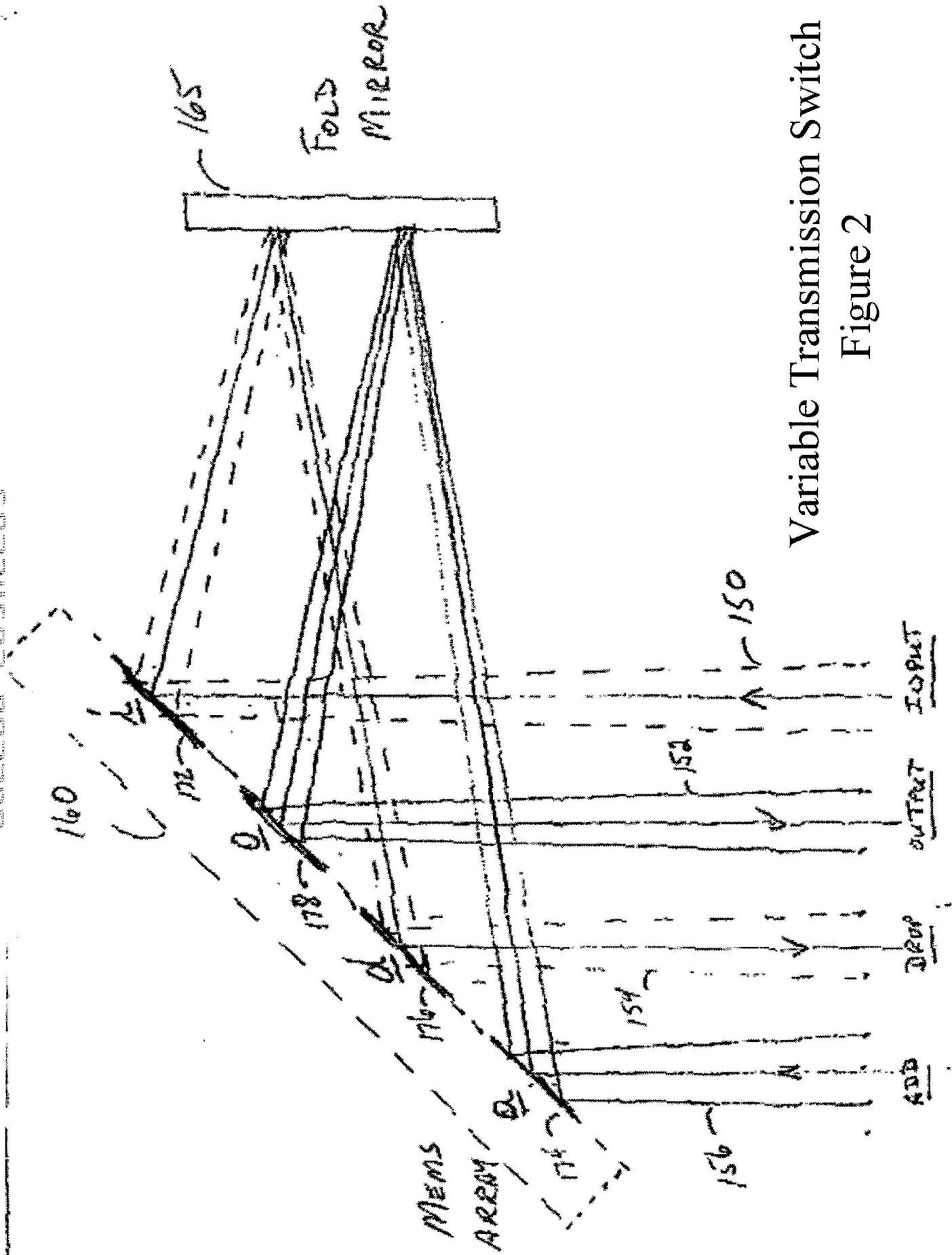

Variable Transmission Switch
Figure 2

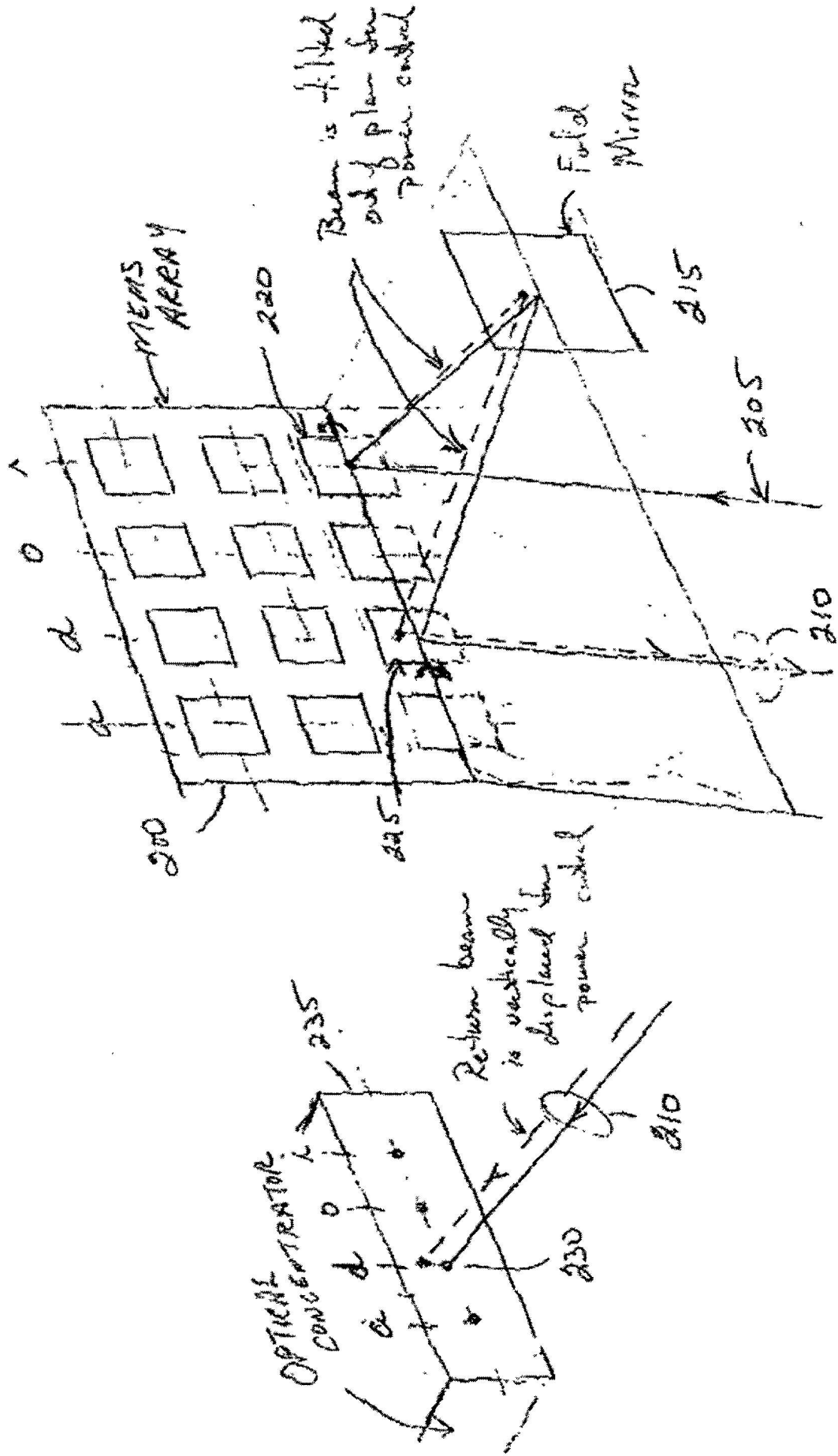

Variable Transmission Switch

Figure 3

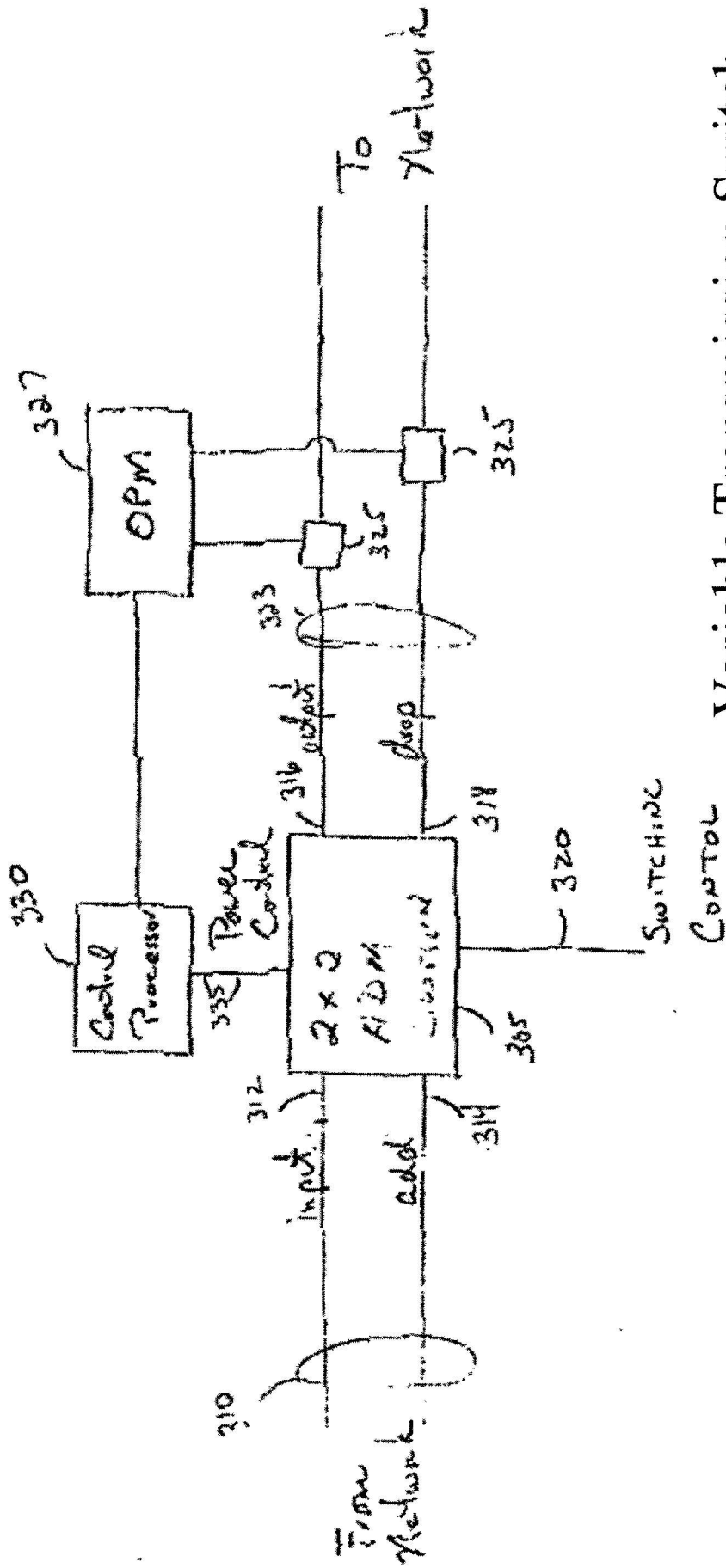

Variable Transmission Switch

Figure 4

Advanced Transparent Network

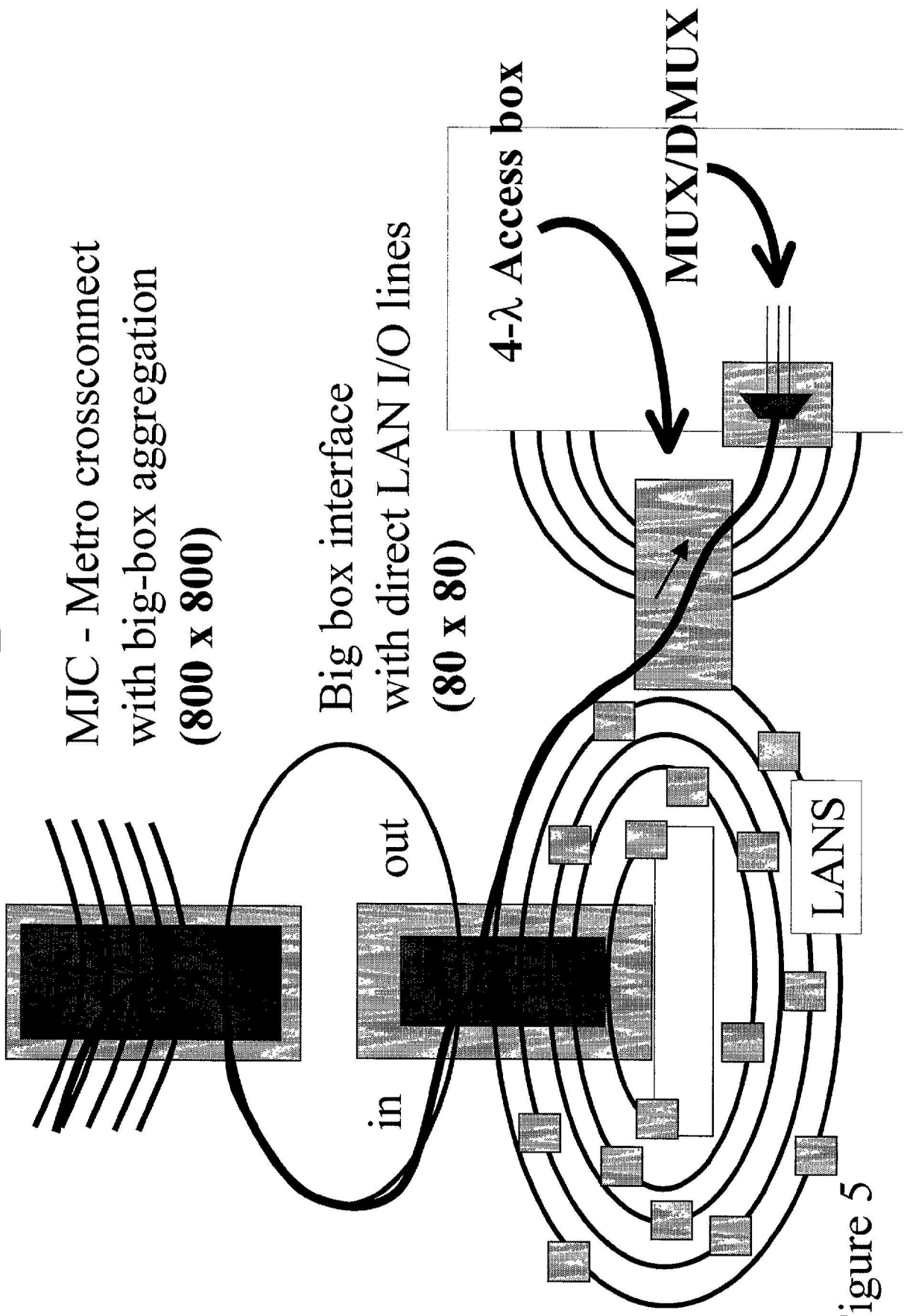
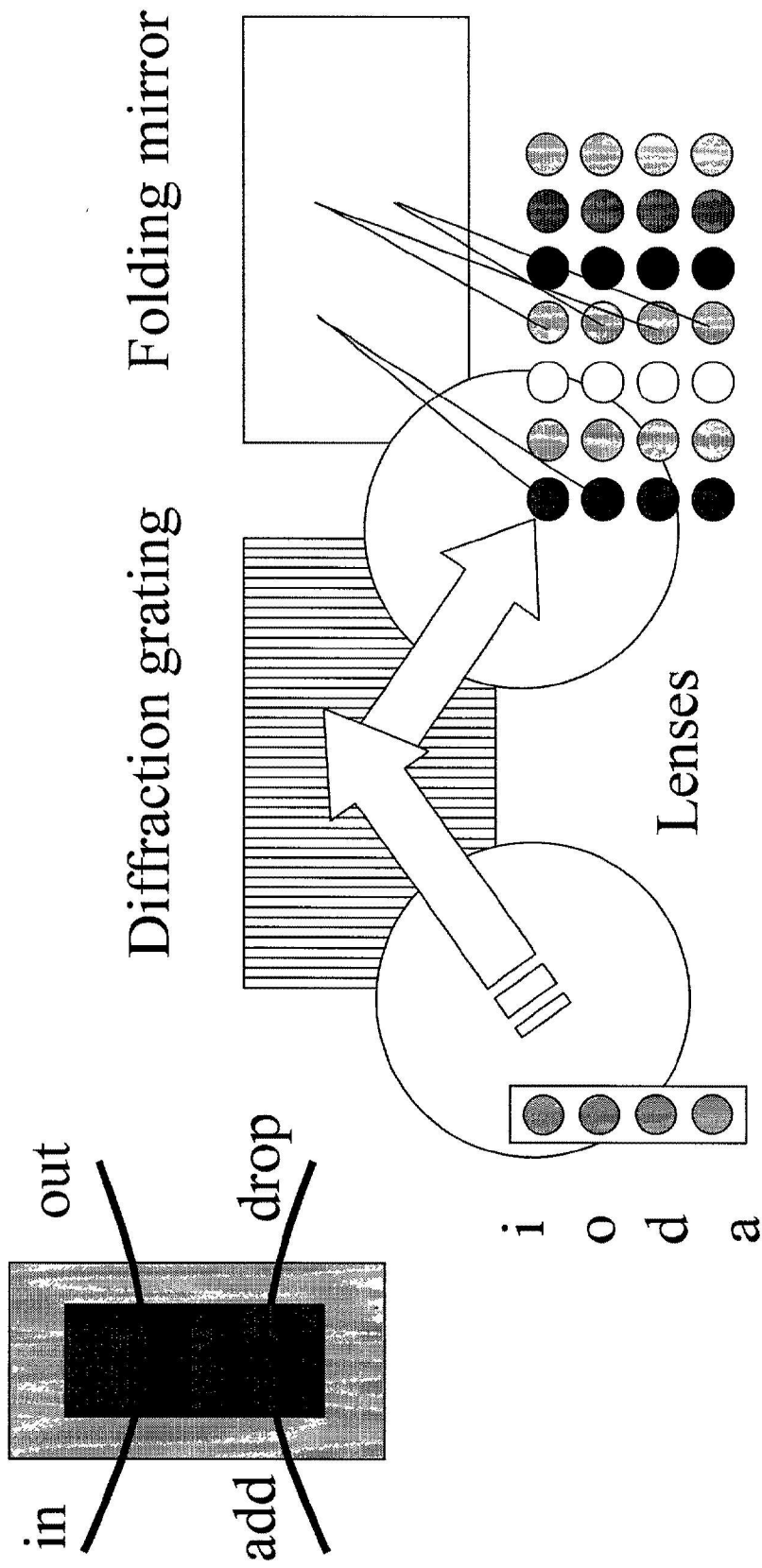

Figure 5

Example: OADM 3-D Design



I/O Fiber Array

MEMS Mirror/Switch Array

Red: thru; Green: exchanged

Figure 6

Mirror Tuning

Figure 7

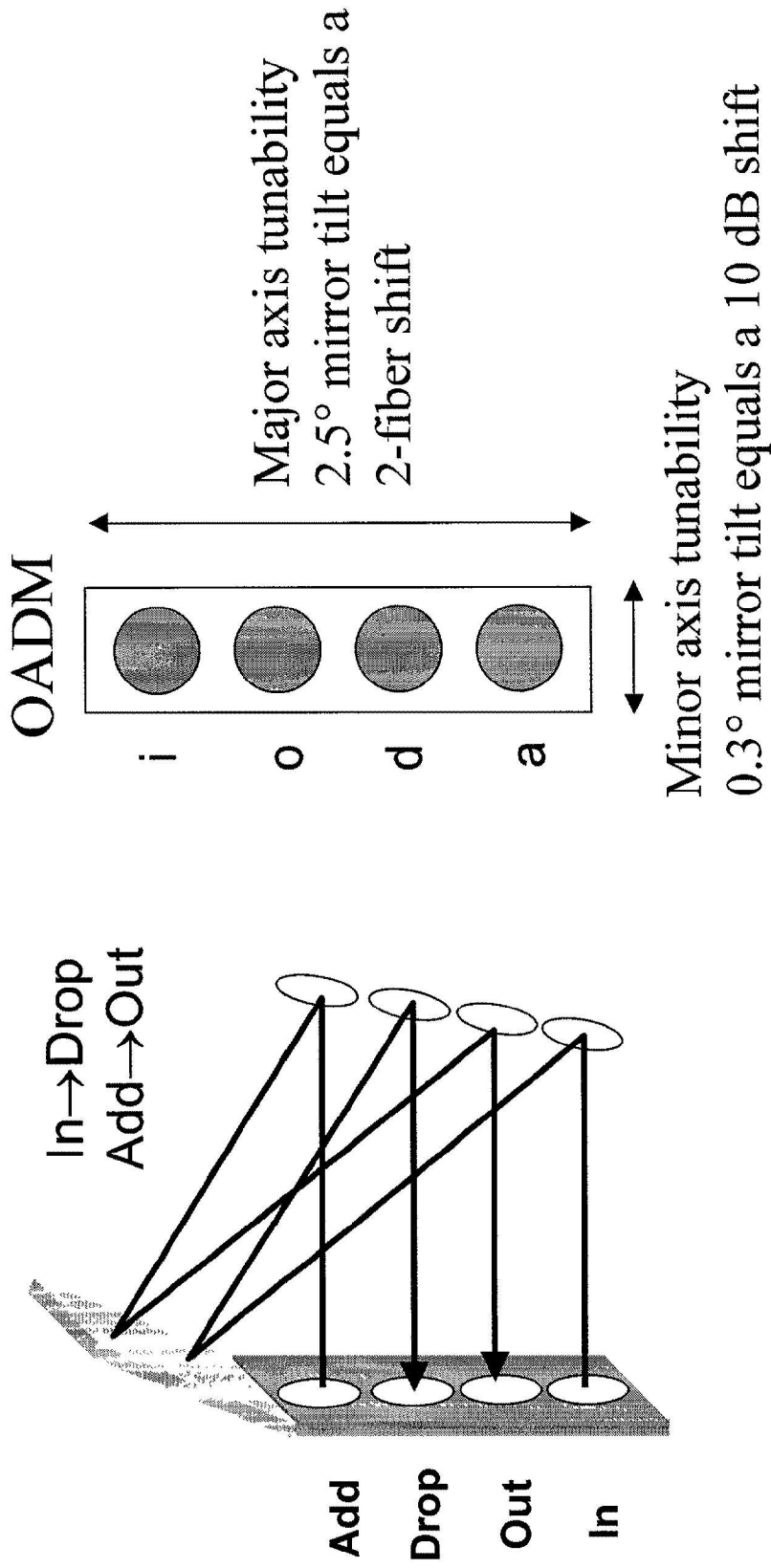

Note: Multiple-LAN OADM needs only 3.8° range

Optical Cross-connect Package

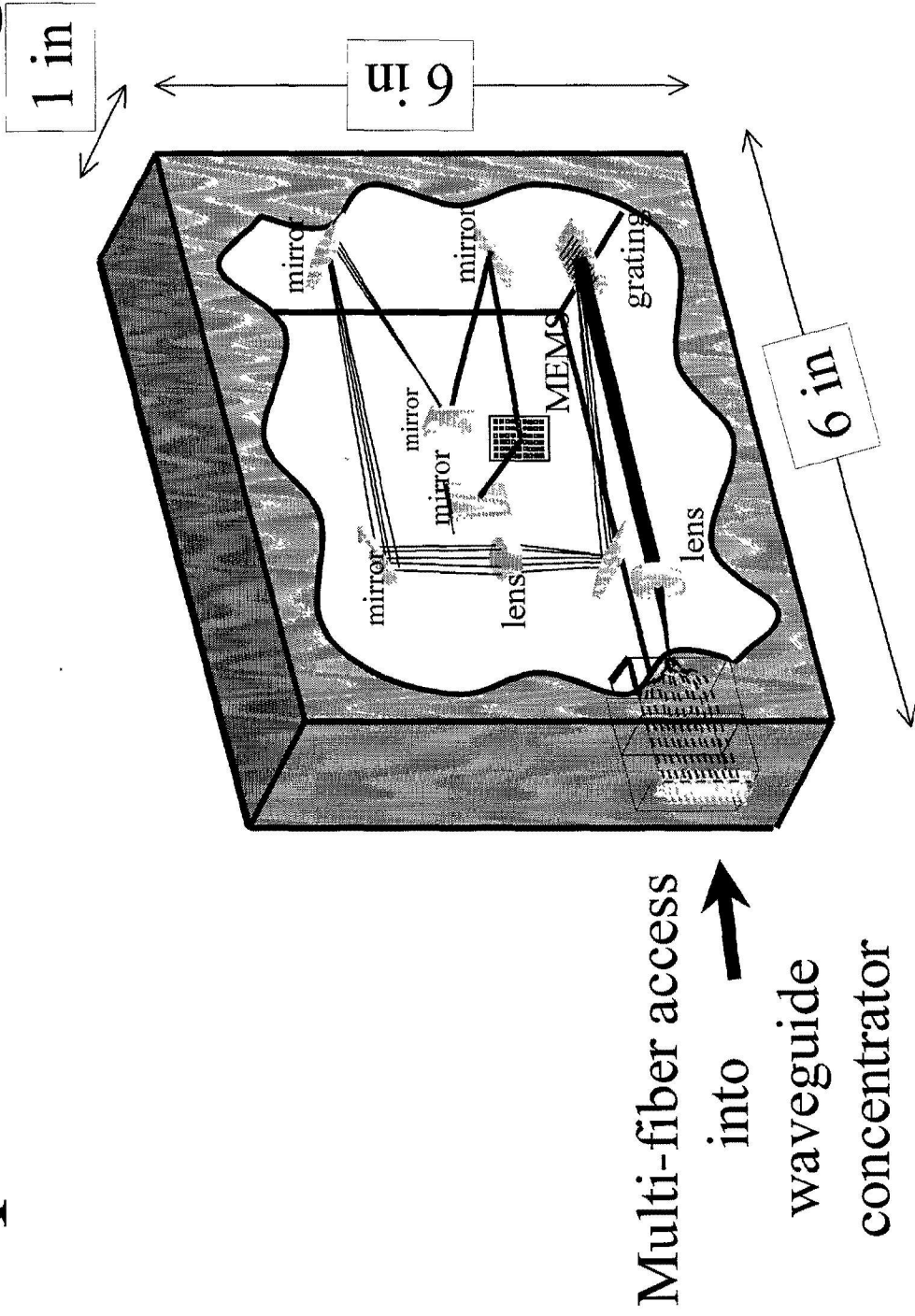
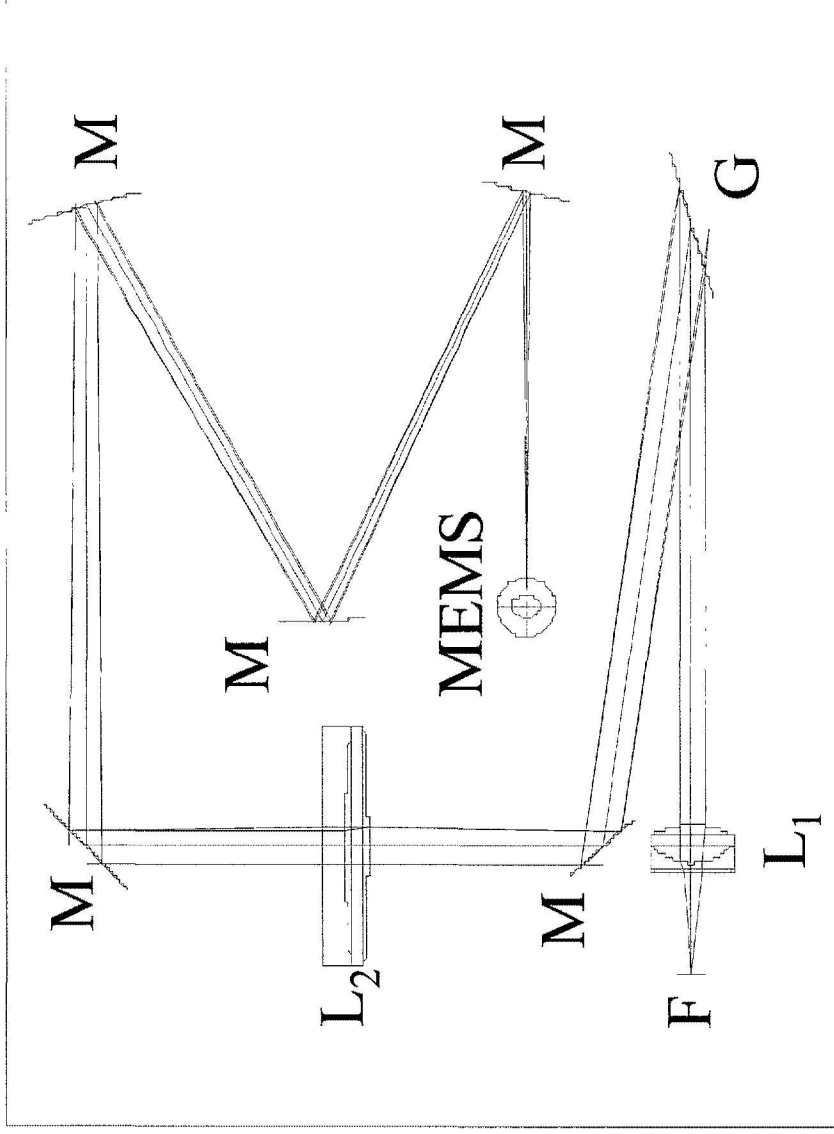

Figure 8

OADM—Optical Engine Layout



- F: Fiber array
- L: Lens
- G: Grating
- M: Mirror
- MEMS waveplate
Plus fold mirror

140 mm

Figure 9

OXC Patent: Power Equalization

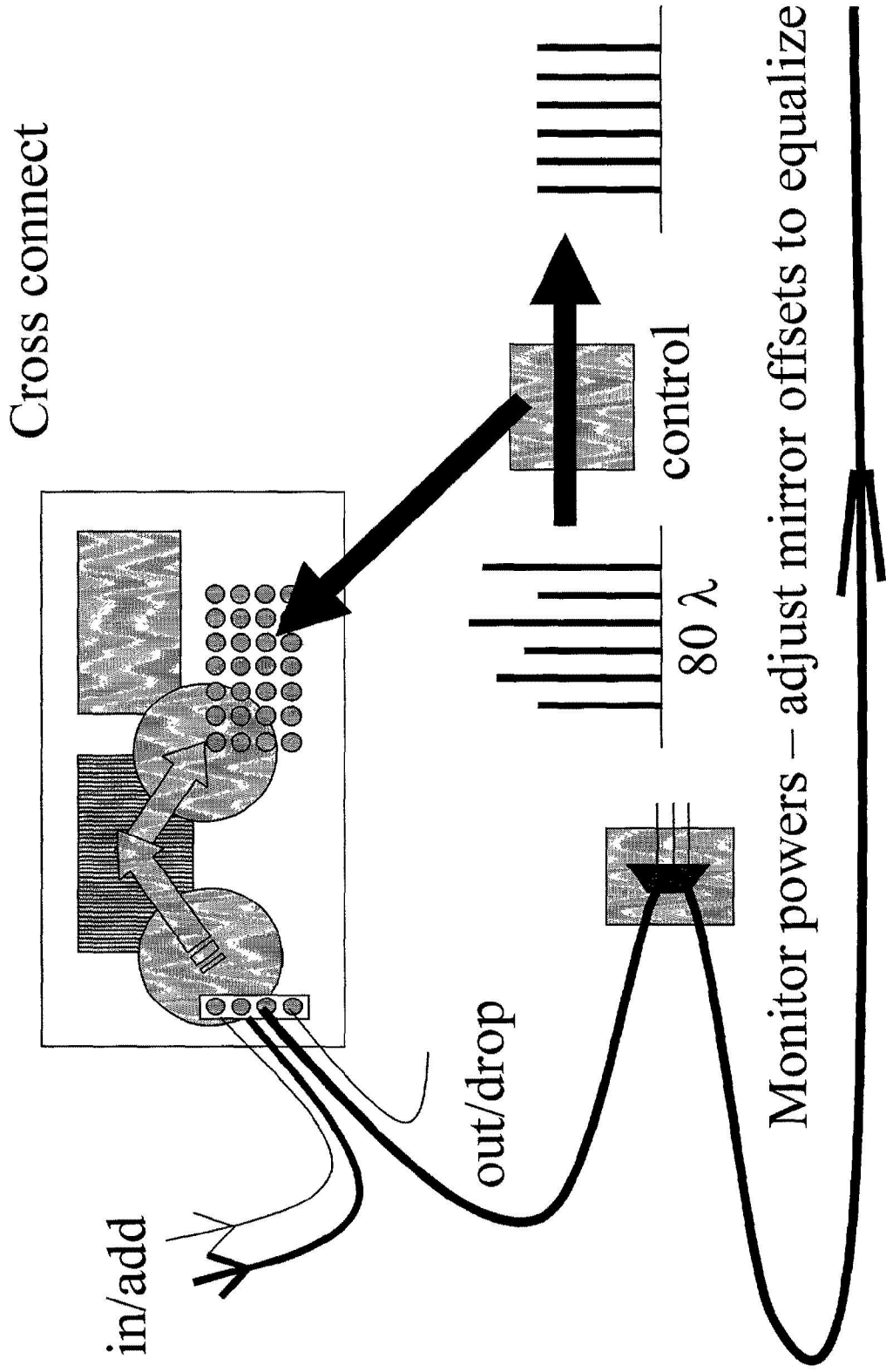
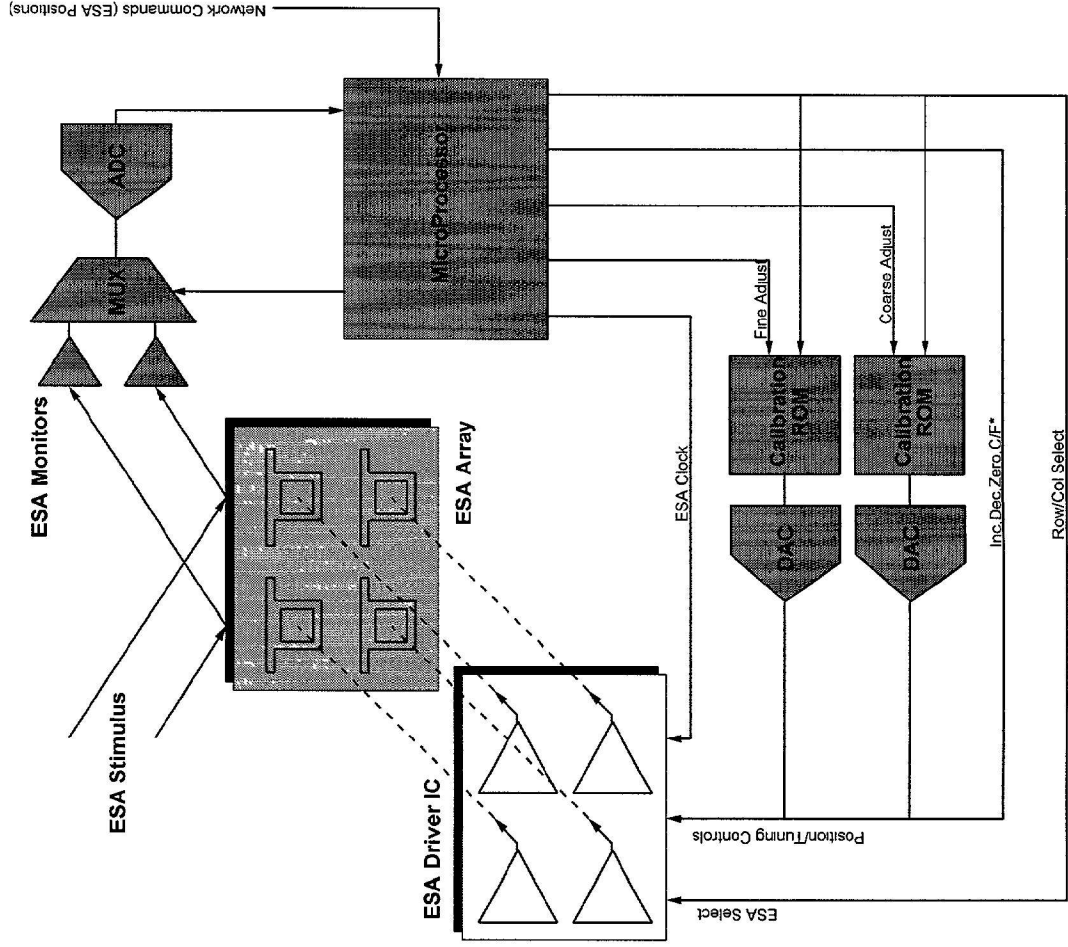

Figure 10

MEMS Mirror Array Drive Electronics



Sequence of Operation

- State signal from NMS
- Adjust mirror position from ROM
- Optimize power from OPM feedback loop
- Equalize power

Key Aspects

- Power: up to 10 mW per pixel
- Small – fits in OXC package
- Continuous field calibration
- Custom HV driver IC

Figure 11