

UNITED STATES PATENT AND TRADEMARK OFFICE

---

BEFORE THE PATENT TRIAL AND APPEAL BOARD

---

Owens Corning,  
Petitioner

v.

CertainTeed Corporation,  
Patent Owner

Patent No. 8,959,876

Issued: February 24, 2015

Filed: June 18, 2014

Inventors: Husnu M. Kalkanoglu and Stephen A. Koch

Title: SHINGLE WITH REINFORCEMENT LAYER

---

*Inter Partes* Review No. 2015-01161

---

**PETITION FOR INTER PARTES REVIEW**

**TABLE OF CONTENTS**

I. Compliance with Requirements of an *Inter Partes* Review Petition ..... 1

    A. Certification that the Patent May Be Contested via *Inter Partes* Review by the Petitioner..... 1

    B. Fee for Inter Partes Review (§ 42.15(a))..... 2

    C. Mandatory Notices (37 CFR § 42.8(b)) ..... 2

        1. Real Party in Interest (§ 42.8(b)(1))..... 2

        2. Other Proceedings (§ 42.8(b)(2))..... 2

        3. Lead and Backup Lead Counsel (§ 42.8(b)(3)) ..... 3

        4. Service on Petitioner ..... 3

    D. Proof of Service (§§ 42.6(e) and 42.105(a)) ..... 3

II. Identification of Claims Being Challenged (§ 42.104(b))..... 3

III. Relevant Information Concerning the '876 Patent..... 4

    A. Background of the Technology ..... 4

        1. The Basic Asphalt Shingle Coated on Both Sides with Asphalt and Granules and Applied to a Roof in Courses Had Been Known for Decades..... 4

        2. The Prior Art Disclosed a Generally Longitudinal Second Thickness Layer For Reinforcement in the Nailing Zone ..... 7

        3. The Prior Art Taught Thin Reinforcement Material..... 11

        4. Laminated Shingles Including Multiple Reinforcement Layers Were Known ..... 12

    B. General Overview Of The '876 Patent..... 14

        1. The '876 Patent Recognizes the Basic Asphalt Shingle Was Known..... 14

        2. Only a Reinforcement Layer Adhered to the Rear Surface Of the Shingle Is Disclosed in the '876 Patent..... 15

        3. The Reinforcement Layer Is “Adhered” to the Surface Of the Shingle in All the Claims ..... 17

    C. Prosecution History and Effective Filing Date of the '876 Patent..... 17

        1. Prosecution of the '876 Patent ..... 17

        2. Prosecution of Related Patent Applications..... 19

            a. U.S. Appl. No. 10/871,911 ..... 19

b.	U.S. Appl. No. 12/857,868 .....	20
3.	Effective Filing Date of the Claims .....	23
D.	Person of Ordinary Skill in the Art .....	23
E.	Construction of Terms Used in the Claims .....	23
1.	Elements (a)–(d) of Claim 1 .....	24
2.	“shingle” .....	24
3.	“adhered to an exterior surface of said shingle” .....	27
4.	“substantially thinner” .....	30
IV.	Precise Reasons for Relief Requested .....	31
A.	Venrick 1939 (Ex. 1013) in View of Frankoski 1998 (Ex. 1010) Renders Obvious Claims 1-22.....	32
1.	Venrick In View Of Frankoski Renders Obvious Claim 1 .....	33
2.	Venrick In View Of Frankoski Renders Obvious Claim 10.....	40
3.	Venrick In View Of Frankoski Renders Obvious Claim 16.....	41
4.	Venrick In View of Frankoski Renders Obvious Claim 22.....	41
5.	Venrick In View Of Frankoski Renders Obvious Claims 6 and 11 .....	41
6.	Venrick In View Of Frankoski Renders Obvious Claim 7 and 14.....	42
7.	Venrick In View Of Frankoski Renders Obvious Claim 17.....	43
8.	Venrick In View Of Frankoski Renders Obvious Claim 20.....	44
9.	Venrick In View Of Frankoski Renders Obvious Claims 8 and 21 .....	44
10.	Venrick In View Of Frankoski Renders Obvious Claims 2, 5, 13 and 18.....	45
11.	Venrick In View Of Frankoski Renders Obvious Claims 3, 4, 12, and 19 .....	46
12.	Venrick In View Of Frankoski Renders Obvious Claims 9 and 15 .....	46
B.	Venrick 1939 (Ex. 1013) in View of Kiik 2001 (Ex. 1018) Renders Obvious Claims 1-22.....	47
1.	Venrick In View Of Kiik Renders Obvious Claim 1.....	47
2.	Venrick In View Of Kiik Renders Obvious Claim 10.....	51
3.	Venrick In View of Kiik Renders Obvious Claim 16.....	52
4.	Venrick In View of Kiik Renders Obvious Claim 22.....	52

5.	Venrick In View Of Kiik Renders Obvious Claims 6 and 11 .....	53
6.	Venrick In View Of Kiik Renders Obvious Claims 7 and 14 .....	53
7.	Venrick In View Of Kiik Renders Obvious Claim 17 .....	54
8.	Venrick In View Of Kiik Renders Obvious Claim 20 .....	55
9.	Venrick In View Of Kiik Renders Obvious Claims 8 and 21 .....	56
10.	Venrick In View Of Kiik Renders Obvious Claims 2, 5, 13, and 18 .....	56
11.	Venrick In View Of Kiik Renders Obvious Claims 3, 4, 12, and 19 .....	57
12.	Venrick In View Of Kiik Renders Obvious Claims 9 and 15 .....	58
C.	Secondary Considerations Do Not Favor Nonobviousness .....	58
V.	CONCLUSION.....	60

**Attachment A. Proof of Service of the Petition**

**Attachment B. List of Evidence and Exhibits Relied Upon in Petition**

## **I. Compliance with Requirements of an *Inter Partes* Review Petition**

### **A. Certification that the Patent May Be Contested via *Inter Partes* Review by the Petitioner**

Petitioner certifies it is not barred or estopped from requesting *inter partes* review of U.S. Patent No. 8,959,876 (“the ’876 patent”) (Ex. 1050). Neither Petitioner, nor any party in privity with Petitioner: (i) has filed a civil action challenging the validity of any claim of the ’876 patent; or (ii) has been served a complaint alleging infringement of the ’876 patent more than one year prior to the present date. Also, the ’876 patent has not been the subject of a prior *inter partes* review or a finally concluded district court litigation involving Petitioner.

Petitioner notes that the timing provisions of 35 U.S.C. § 311(c) and 37 C.F.R. § 42.102(a) do not apply to the ’876 patent, as its effective filing date pre-dates the first-to-file system. *See* Pub. L. 112-274 § 1(n), 126 Stat. 2456 (Jan. 14, 2013). Furthermore, as discussed below, Patent Owner’s submission of additional information prior to the Examiner’s issuance of the Notice of Allowance for the ’876 patent does not preclude institution pursuant to 35 U.S.C. § 325(d). There is no evidence the Examiner gave due consideration to the information that was submitted, Petitioner’s arguments have merit, and Petitioner was unable to make these arguments during prosecution. *See SK Innovation Co., Ltd. v. Celgard, LLC*, IPR2014-00680, Paper No. 11(Sept. 29, 2014) at 22; *Conopco, Inc. v. The Procter & Gamble Co.*, IPR No. 2013-00505, Paper No. 9 (Feb. 12, 2014) at 6.

**B. Fee for Inter Partes Review (§ 42.15(a))**

The Director is authorized to charge Deposit Account No. 50-1597.

**C. Mandatory Notices (37 CFR § 42.8(b))**

**1. Real Party in Interest (§ 42.8(b)(1))**

The real party in interest is Owens Corning, located at One Owens Corning Parkway, Toledo, OH 43659.

**2. Other Proceedings (§ 42.8(b)(2))**

The '876 patent is not subject to any litigation, but patents related to the '876 patent are the subject of litigation in the District of Delaware (Civ. A. No. 1:14-cv-00510-SLR), which names Owens Corning as defendant. *See* Ex. 1045 (Complaint). These same related patents, of which the '876 patent is related by continuation, are also the subject of petitions for *inter partes* review filed on August 29, 2014 (IPR Nos. 2014-01397, -01401, -01402, -01403, -01404). On March 9, 2015, the Board correctly instituted trial on all of the challenged claims in each of these proceedings based on the Venrick, Frankoski, and Kiik references, which are the subject of the instant petition. Additional patents related to the '876 patent are also the subject of *inter partes* review proceedings, IPR Nos. 2015-01159 and 2015-01160, which are filed concurrently with the instant petition.

The subject matter of the '876 patent is substantially identical to the subject matter of the claims on which the Board has already instituted *inter partes* review. Therefore, *inter partes* review should be instituted for the '876 patent, as explained

in detail below.

**3. Lead and Backup Lead Counsel (§ 42.8(b)(3))**

<u>Lead Counsel</u> Jeffrey P. Kushan Reg. No. 43,401 <a href="mailto:jkushan@sidley.com">jkushan@sidley.com</a> (202) 736-8914	<u>Backup Lead Counsel</u> Peter S. Choi Reg. No. 54,033 <a href="mailto:peter.choi@sidley.com">peter.choi@sidley.com</a> (202) 736-8076
---	--

**4. Service on Petitioner**

Service on Petitioner may be made by mail or hand delivery to: Sidley Austin LLP, 1501 K Street, N.W., Washington, D.C. 20005. The fax number for Petitioner's counsel is (202) 736-8711.

**D. Proof of Service (§§ 42.6(e) and 42.105(a))**

Proof of service of this petition is provided in **Attachment A**.

**II. Identification of Claims Being Challenged (§ 42.104(b))**

Claims 1–22 of the '876 patent are unpatentable. Specifically:

- (1) Claims 1–22 would have been obvious under 35 U.S.C. § 103 based on U.S. Patent No. 2,161,440 to Venrick (Venrick) (Ex. 1013) in view of U.S. Patent No. 5,822,943 to Frankoski (Frankoski) (Ex. 1010).
- (2) Claims 1–22 would have been obvious under 35 U.S.C. § 103 based on Venrick in view of U.S. Patent Publ. No. 2001/0055680 to Kiik (Kiik) (Ex. 1018).

Petitioner's proposed claim construction, the evidence relied upon, and the precise reasons why the claims are unpatentable are provided below. A list of

evidence relied upon in support of this petition is set forth in **Attachment B**.

### **III. Relevant Information Concerning the '876 Patent**

#### **A. Background of the Technology**

##### **1. The Basic Asphalt Shingle Coated on Both Sides with Asphalt and Granules and Applied to a Roof in Courses Had Been Known for Decades**

Asphalt shingles have been used to cover roofs since the late-1800s. *See, e.g.*, Ex. 1005, Cash, “Asphalt Roofing Shingles,” Proc. 11<sup>th</sup> Conf. Roofing Tech. (1995) (Cash), at 1; Declaration of Mike Bryson, Ex. 1003 at ¶ 43. By the mid-1990s, three styles predominated: (1) the individual shingle; (2) the strip shingle (with or without tabs), and (3) the laminated shingle (with or without tabs). Ex. 1005 (Cash), at Figs. 10–12; Ex. 1003 at ¶ 43.

Asphalt is applied to waterproof the shingle. Ex. 1007, Noone, “Asphalt Shingles – A Century of Success and Improvement,” Proc. 11<sup>th</sup> Conf. Roofing Tech. (1993) (Noone 1993), at 2; Ex. 1003 at ¶ 46. In general, making an asphalt shingle involves passing a base mat through a coater, where layers of hot asphalt are applied to the top and back surfaces. Ex. 1007 at 2; Ex. 1003 at ¶ 46. Colored or non-colored granules are then dropped on the front surface and other granular materials are applied to the back. Ex. 1007 at 2, 5; Ex. 1003 at ¶ 46. The granular material on the front adds color and texture while finely ground talc and sand or other granular materials on the back prevent sticking during storage and shipment.



Ex. 1007 at 2, 5-6; Ex. 1003 at ¶ 46.

The basic steps for making an asphalt shingle, including coating both sides of the base mat (*i.e.*, substrate) with asphalt and then applying granular material on both sides, have remained the same for decades. Ex. 1003 at ¶¶ 46-51. U.S. Patent No. 2,099,131 (issued in 1937) (Miller 1937) (Ex. 1008) states:

It has heretofore been common practice to manufacture prepared roofing by saturating a suitable absorbent fabric, such as roofing felt, with a liquid bituminous material, e.g., asphalt, coating both sides of the saturated fabric with a bituminous material, surfacing the bituminous coating on one side of the fabric with mineral grit, such as crushed slate, and applying mica, soapstone, or other anti-stick material to the coating on the other side of the fabric.

*Id.* at 4, col. 1:13–24 (emphases added); Ex. 1003 at ¶ 48.

A typical strip shingle includes a plurality of tabs (*i.e.*, flaps) of uniform or varying dimensions that extend downwardly from a headlap area. Ex. 1003 at ¶¶ 44-45, 54-55. Each asphalt shingle has a nailing or fastening zone for attachment to a roof. *Id.* The 1997 edition of the ARMA Residential Roofing Manual (ARMA Manual) (Ex. 1009), at 33, Fig. 10 (below), shows the nailing zone typically is located just above the tabs in the headlap area. Also shown is the generally longitudinal dimensions of the typical strip shingle, *i.e.*, 36” x 12”. Ex. 1003 at ¶¶ 54-56; *see also id.* at ¶¶ 52-53.

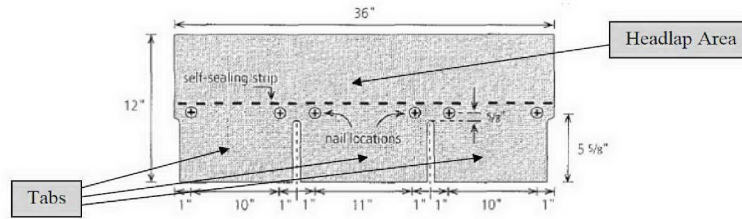

As shown, the nailing zone is (a) generally longitudinal, (b) located between the right and left edges, and (c) intermediate of the upper and lower edges. *Id.* at ¶ 56.

The preamble of claim 1 of the '876 patent provides: “[a]n array of shingles applied to a roof, by fasteners, in courses, each shingle having front and rear exterior surfaces and being comprised of shingle material, with the shingle having a wi[d]th defined by upper and lower edges and a length defined by right and left edges.” Ex. 1050 at 7:35-39. Elements (a)–(d) of claim 1 require the following:

- (a) a base layer of mat having front and rear surfaces;
- (b) a coating of asphaltic material on both front and rear surfaces of the mat;
- (c) coatings of granular material on said both front and rear surfaces of the mat, which, together with said base layer of mat and said coating of asphaltic material comprise a first thickness layer;
- (d) a longitudinal fastening zone between right and left shingle edges, generally intermediate said upper and lower edges[.]

*Id.* at col. 7:40-49. These elements and the preamble describe nothing more than the basic asphalt shingle applied to a roof in a convention manner. Ex. 1003 at ¶¶

57-60. The '876 patent acknowledges that the “basic” asphalt shingle was known in the prior art. Ex. 1050 at col. 3:17-20; Ex. 1003 at ¶¶ 61-62. Fastening this basic asphalt shingle to a roof in overlapping layers—known as “courses” in the industry—using fasteners has been “common practice” since at least the 1930s. Ex. 1003 at ¶¶ 45, 58.

To the basic asphalt shingle, element (e) of claim 1 of the '876 patent adds and describes a “reinforcement second thickness layer”:

(e) and an at least partially externally visible generally longitudinal reinforcement second thickness layer of a substantially thinner dimension than said first thickness layer; said reinforcement second thickness layer being adhered to an exterior surface of said shingle, being at least partially within said fastening zone and being at least substantially between right and left edges of the shingle.

Ex. 1050 at col. 7:45–57; *see also id.* at col. 3:29-31 (“the shingle 20 is similar to that of the [prior art] shingle 10 of FIG.1, but with a reinforcement layer”).

Reinforcement layers having the claimed features were known in the prior art. Ex. 1003 at ¶¶ 79-80; *see id.* at § II.C.3.

## **2. The Prior Art Disclosed a Generally Longitudinal Second Thickness Layer For Reinforcement in the Nailing Zone**

U.S. Patent No. 2,161,440 to Venrick (Venrick) describes a “reinforcing strip” for “strengthening” to “reduce . . . tear,” and to “provide a ***reinforced*** area for nailing the shingle to the roof.” Ex. 1013 (Venrick), at 3, col. 1:40–46

(emphasis added); Ex. 1003 at ¶ 84.

Although the Venrick strip, which may be made of, *inter alia*, felt, metal, or “layers of roofing tape,” Ex. 1013 at 4, col. 2:74–75, can serve an aesthetic purpose, a distinct purpose for the strip is to add “rigidity” to the shingle to “rigidity” to “resist[] the action of the wind.” *Id.* at 5, col. 1:1-9; at 3, col. 1:40-46 (“reinforced area for nailing” “[a]nother object”); Ex. 1003 at ¶ 85. “[I]mproved resistance to failure upon bending” is a function of the reinforcement layer in the ’876 patent. Ex. 1050 at col. 6:32-33; Ex. 1003 at ¶ 85. The reinforcing strip of Venrick is shown in Fig. 1 as 15 on the front surface of a shingle.

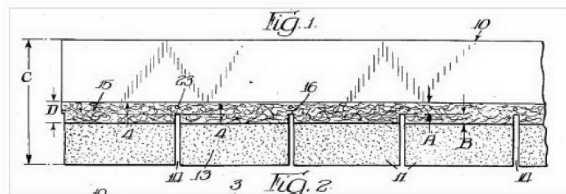

Venrick teaches that the reinforcement strip can also be on the “undersurface,” or rear surface of the shingle. Ex. 1013 at 4, col. 2:60–63, Figs. 8–14; Ex. 1003 at ¶¶ 86-87. The strip is preferably “cemented” onto the granule surfacing, and overlaps with the nailing zone to “give greater nailing strength.” Ex. 1013 at 4, col. 1:32-37, col. 2:11–23; Ex. 1003 at ¶ 87.

Figs. 8 and 9 of Venrick show the reinforcement strip 45 as a visible component that is adhered to the exterior rear surface. Ex. 1003 at ¶ 88. It extends at least partially into the zone having nailing holes 47, and it also extends lower

than the nailing zone (*i.e.*, into the tab portion toward the lower edge of the shingle), as shown by the hashed lines. *Id.* It also extends toward the upper edge into the lower end of the headlap area. *Id.* It clearly forms a second thickness layer. *Id.* The strip is also generally longitudinal as would be expected given that shingles are generally longitudinal. *Id.*

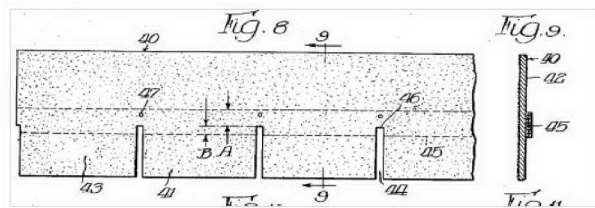

It was known long before the priority date of the '876 patent that nailing through multiple layers of shingle material provided strength and contributed to roofing integrity. *Id.* at ¶ 89. *E.g.*, U.S. Patent No. 6,145,265 (Ex. 1011), at col. 1:60–62 (“[N]ailing through a double layer of material provides strength, which is essential for roofing integrity in windy conditions.”). Because the nailing zone was generally longitudinal, *see* Ex. 1009 (ARMA Manual 1997), at 33, Fig. 10, it would only make sense to make the reinforcement layer generally longitudinal while extending it at least partially into the nailing zone. Ex. 1003 at ¶ 89. This is what Venrick teaches. Ex. 1013 at 5, col. 1:50–54 (“The shingles are nailed preferably . . . where the raised median strip is.”); *see also id.* at 5, col. 1:1–3 (“the strip . . . extends longitudinally thereof”).

Examples of reinforcing layers affixed to the rear surface abound. U.S.

Patent No. 4,875,321 (Rohner) (Ex. 1015) discloses a “backing strip” (Fig. 2, 25) that can be made of “light-weight weather-resistant material” to “provide[] a stiffer shingle which grips the nails....” *Id.* at col. 1:55–59, 2:30-32; Ex. 1003 at ¶ 94.

Fig. 2 exemplifies a shingle with a reinforcing backing layer 25. Ex. 1003 at ¶ 94.

Showing an array of shingles, Fig. 3 confirms that the rear facing reinforcing layer 25 extends at least partially into the nailing zone 37. Ex. 1015 (Rohner); Ex. 1003 at ¶ 95. The Rohner “backing strip” forms a second thickness layer on the rear, and is longitudinal like the shingle itself. Ex. 1003 at ¶ 95.

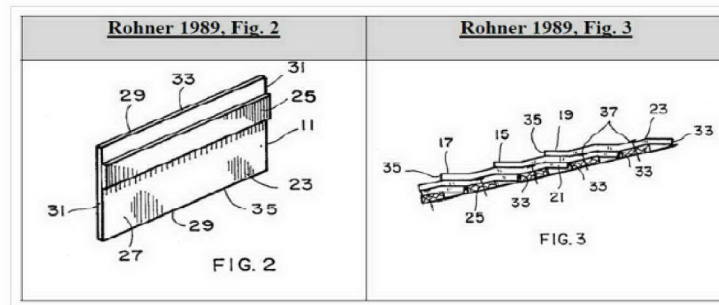

Similarly, U.S. Patent No. 5,860,263 (Sieling) (Ex. 1016) shows a “reinforcement” strip 60 affixed to the back portion of an asphalt shingle. *Id.* at ¶ 96. Sieling describes the reinforcing strip as having dimensions which would have been understood to fall within the nailing zone. Ex. 1016 at col. 3:23-28; Ex. 1003 at ¶ 97. The reinforcing strip in Sieling is on the exterior surface, forms a second thickness layer, and is longitudinal in orientation. Ex. 1003 at ¶ 97; *see id.* at §§ II.C.3.-II.C.3.a., V.E.

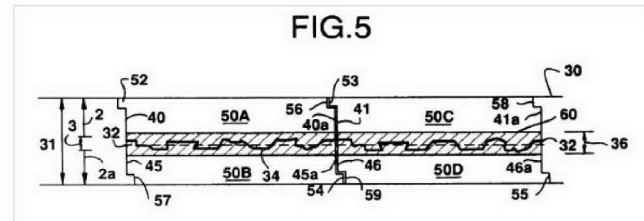

### 3. The Prior Art Taught Thin Reinforcement Material

Venrick, Rohner, and Sieling show the concept of using a reinforcing layer on the back of a shingle was not new. *Id.* at ¶¶ 84-89, 94-97; *see id.* at § II.C.3.a. Nor was the concept of using thin material for reinforcement. *Id.*; *see id.* at §§ II.C.3.b.-II.C.3.c.

U.S. Patent No. 3,813,280 (Olszyk) (Ex. 1014) shows a web layer 16 affixed to the back of an asphalt shingle. *Id.* at ¶¶ 90-91.

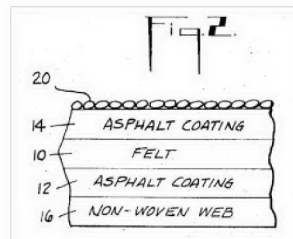

A purpose of the web layer is “**adding reinforcement** ...and providing **additional tear strength**.” Ex. 1014 at col. 4:17-27 (emphases added); Ex. 1003 at ¶ 91. The thickness of the web is on the order of 1/1000<sup>th</sup> of an inch. Ex. 1014 at col. 3:59-60 (“a thickness of between about 10 mils or less to about 30 mils”); Ex. 1003 at ¶¶ 92-93; *see also id.* at § V.B.

U.S. Patent Publ. No. 2001/0055680 (Kiik) (Ex. 1018) discloses an asphalt roof shingle having a “backing material” that can be made of woven polyester and

latex fiber bound by latex. *Id.* at [0004], [0006]; Ex. 1003 at ¶¶ 100–101. The exemplary materials have a thickness of 13-23 1/1000<sup>th</sup> of an inch. Ex. 1018 at Table I; Ex. 1003 at ¶ 101. Data in Kiik show the reinforced laminated shingles exhibited improved tear strength and nail pull strength. Ex. 1018 at Tables I, II; Ex. 1003 at ¶ 104. Thus, Kiik showed thin material could be affixed to the back of an asphalt shingle to provide reinforcing properties. Ex. 1003 at ¶¶ 102-104.

U.S. Patent No. 5,822,943 (Frankoski) (Ex. 1010) issued in 1998. *Id.* at ¶ 63. The '875 patent incorporates by reference Frankoski and says the “basic” asphalt shingle can be made according to the teachings of Frankoski. Ex. 1048 at col. 3:14–17; Ex. 1003 at ¶¶ 61–62. As discussed in detail below, Frankoski discloses a scrim—a thin material, preferably 0.37 inches, made from any number of different fabric, synthetic, or composite materials—that serves to reinforce the shingle. Ex. 1010 at 3:24–36; Ex. 1003 at ¶¶ 69–70. Like Kiik, data in Frankoski evidences that scrim “provides a superior strength and nail pull-through resistance to withstand, for example, hurricane force winds.” Ex. 1010 at col. 3:20–24, 5:64–8:63 (providing nail pull resistance, tensile strength, and tear resistance data); Ex. 1003 at ¶¶ 70, 76.

#### **4. Laminated Shingles Including Multiple Reinforcement Layers Were Known**

As discussed above, Frankoski discloses a laminated shingle, exemplified by Figs. 1 and 2 of Frankoski. Ex. 1003 at ¶¶ 63-69, 109. A laminated shingle is a



shingle made of two layers that are glued together. *Id.*; *see id.* at ¶¶ 49-50, 59.

Fig. 1 of Frankoski shows the shingle comprises an upper layer 5 and a lower layer 7, which are glued together with a sealant 9. *Id.* at ¶ 64. The upper layer 5 has a headlap area 10 and a number of tabs 35. *Id.* The lower layer is generally longitudinal, and extends between the right and left edges. *Id.*

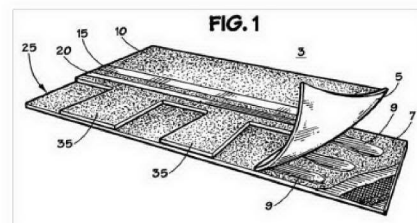

It was widely known that gluing an extra shingle layer to the back surface of a single layer strip shingle, as in a laminated shingle, provided reinforcement properties by enabling a roofer to nail through two layers, rather than one layer, of material. *Id.* at ¶ 68. U.S. Patent No. 6,145,265 (Malarkey) (Ex. 1011) explains this common-sense principle, noting that “**nailing through a double layer of material provides strength.**” *Id.* at col. 1:54-62 (emphasis added); Ex. 1003 at ¶ 68. Laminated shingles, which were among the most popular shingles made and sold by the late 1990s and early 2000s, utilized a second thickness layer of material that was recognized to add reinforcement. Ex. 1003 at ¶ 68.

Further, Fig. 2 of Frankoski (Ex. 1010) shows a scrim layer 60 in the laminated shingle that serves as a reinforcement layer that provides additional strength and support to the shingle. *Id.* at ¶¶ 69-70; *see id.* at ¶¶ 71-78; Ex. 1010 at

col. 3; 20-24, Fig. 2.

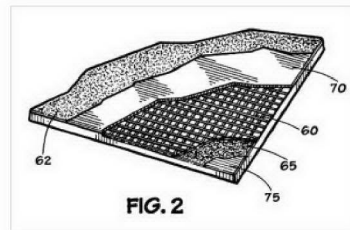

Frankoski states that the scrim preferably extends the entire length of the shingle. Ex. 1010 at col. 5:27–28. This would be understood to mean the scrim is generally longitudinal given that most shingles were longer than they were wide. Ex. 1003 at ¶ 73. Frankoski states the scrim should “coincide with at least a portion of the nail zone.” Ex. 1010 at col. 5:38-39; Ex. 1003 at ¶ 73.

As discussed in § III.C.2., in related applications, Patent Owner distinguished the alleged invention over Frankoski by arguing the reinforcing layer is not “embedded” within the shingle as the scrim 60 is in Frankoski; instead it is affixed to the exterior, rear surface of the shingle. At the time these arguments were made, neither Venrick, Rohner, nor Sieling were before the Patent Office. See Ex. 1003 at §§ III.G.-III.H.

## **B. General Overview Of The '876 Patent**

The '876 patent, entitled “Shingle With Reinforcement Layer,” issued on February 24, 2015, to Kalkanoglu and Koch. Ex. 1050. See Ex. 1003 at § III.C.

### **1. The '876 Patent Recognizes the Basic Asphalt Shingle Was Known**

The '876 patent acknowledges that the basic components of an asphalt

shingle are prior art. Ex. 1050 at col. 2:63–3:20. Referring to Fig. 1, the '876 patent describes the “prior art shingle” as being made of a mat covered with asphalt on “each exposed surface” with “granular material” on the upper exposed surface to withstand weather and “smaller granules” on the “undersurface.” *Id.* at col. 2:63-3:6. The '876 patent states that the “basic” prior art shingle can be made by the methods disclosed in, among other references, Frankoski. *Id.* at col. 3:17–20; Ex. 1003 at ¶¶ 61-62.

**2. Only a Reinforcement Layer Adhered to the Rear Surface Of the Shingle Is Disclosed in the '876 Patent**

The person of ordinary skill would understand that the reinforcement layer disclosed in the '876 patent is affixed to the rear surface of the asphalt shingle, and nowhere else. Ex. 1003 at ¶¶ 134, 186; *see also id.* at § III.A.2.

The specification states: the “present invention is directed toward providing a shingle, wherein, a separate, *exterior reinforcement layer* is provided *outside the rear surface of the shingle...*” Ex. 1050 at col. 1:60–64 (emphases added); Ex. 1003 at ¶¶ 135, 186.

The figures provided in the '876 patent show the reinforcement layer to be located only on the rear surface of the shingle. Ex. 1003 at ¶ 186; *see id.* at § III.A.2. Fig. 2 shows a prior art shingle with a “reinforcement layer applied to the rear surface thereof, in accordance with the present invention.” Ex. 1050 at col. 2:26–28 (emphases added); Ex. 1003 at ¶¶ 137–38, 186. Fig. 3 also shows the

reinforcement layer on the “rear surface.” Ex. 1050 at col. 2:30–32; Ex. 1003 at ¶¶ 139, 186.

The specification consistently emphasizes location of the reinforcement layer on the “rear surface.” *See, e.g.*, Ex. 1050, at Figs. 4 and 4A (reinforcement layer 29 on rear surface of shingle); col. 1:60–62 (“reinforcement layer is provided *outside the rear surface*”); col. 3:31–34 (“a reinforcement layer . . . *added on the rear* 21 of the shingle”); col. 4:25–27 (“the scrim 46 *applied to the undersurface*”); col. 6:31–7:28 (extolling performance of “scrim reinforcement embedded *on their rear sides*,” a “polyester mat reinforcement layer *on their rear surfaces*,” a heavier “reinforcement layer *on the rear surface*,” “fiber glass scrim *on the rear surface*,” and “reinforcement material that is *applied to the rear*”) (emphases added); Ex. 1003 at ¶¶ 141, 186.

Moreover, the specification describes only one method for making the described shingle, and this method places the reinforcement layer on the rear surface; that is again described as being required for the “invention.” Ex. 1050 at col. 4:8–15 (“[T]he reinforcement layers 29, 39 may . . . [be] either embedded in the asphaltic layer *on the rear* of the shingle or *adhered to the rear* of the shingle . . . . The reinforcement layer 29, 39, will be *adhered to the rear surface* 21, 31 of the shingles *of this invention*, by means of any suitable adhesive. . . .” (emphases added)); Ex. 1003 at ¶¶ 142, 186. Placement on the rear is also

described to be critical to performance. *Id.* ¶¶ 143–44, 186. For example, Figure 4 illustrates that “the scrim 46 applied to the undersurface of the shingle 41 will tend to resist upward bending of the shingle tab portion 44...” Ex. 1050 at col. 4:25–27 (emphasis added); Ex. 1003 at ¶¶ 145, 186.

### **3. The Reinforcement Layer Is “Adhered” to the Surface Of the Shingle in All the Claims**

The specification draws a distinction between a reinforcement layer that is “adhered” to the shingle and one that is “embedded”: “the reinforcement layers” are “either embedded in the asphaltic layer on the rear of the shingle or adhered to the rear of the shingle...” Ex. 1050 at col. 4:10–12 (emphases added); Ex. 1003 at ¶¶ 147–49, 186.

The claims of the ’876 patent all require a reinforcement layer that is “adhered” to the shingle. Ex. 1050 at col. 7:35–10:36. As explained in § III.C.2., during prosecution of related applications, Patent Owner distinguished Frankoski because it disclosed an “embedded” reinforcement layer, as opposed to one adhered to an external, rear surface of the shingle.

## **C. Prosecution History and Effective Filing Date of the ’876 Patent**

### **1. Prosecution of the ’876 Patent**

On April 22, 2014, Patent Owner filed a complaint alleging Petitioner infringed patents related to the ’876 patent by continuation. Ex. 1045 (Complaint). Patent Owner filed Appl. No. 14/307,677 on June 18, 2014. Ex. 1050. On August

29, 2014, Petitioner filed five petitions for *inter partes* review, challenging these related patents. Subsequently, on September 18, 2014, Patent Owner notified the Examiner of the pending petitions and district court litigation. Ex. 1051 ('677 Appl. File Wrapper), at 104. Patent Owner amended its claims; specifically, it deleted “woven or non-woven” as a requirement for materials selected for the reinforcement second layer making other minor adjustments (*e.g.*, replacing “extending” with “being” where describing the location of the reinforcement layer). *Id.* at 88-93. At the same time, Patent Owner submitted an Information Disclosure Statement that cited all prior art cited in Petitioner’s *inter partes* review petitions challenging related patents, and the declaration of Petitioner’s expert, Mr. Bryson, submitted by Petitioner in its filings. *Id.* at 78-81. Notably, **the IPR petitions themselves were not submitted**. On October 14, 2014, Patent Owner filed another Information Disclosure Statement citing three secondary references cited in Petitioner’s *inter partes* review petitions. *Id.* at 43-44. No prior art rejections were ever made by the Examiner during prosecution. On October 15, 2014, a Notice of Allowance issued, but despite the newly submitted information, no reasons for allowance were provided by the Examiner pursuant to MPEP 1302.14. *Id.* at 16. On October 24, 2014, a Supplemental Notice of Allowance issued, once again allowing the claims in view of the previously submitted Information Disclosure Statement. *Id.* at 10. On February 24, 2015, the '677

application issued as U.S. Patent No. 8,959,876. *Id.* at 1; *see* Ex. 1003 at § III.F.

## 2. Prosecution of Related Patent Applications

The '677 application that resulted in the issuance of the '876 patent is related, by continuation, to a number of earlier-filed applications. *See* Ex. 1003 at §§ III.G.-III.H. Frankoski played a prominent role during the prosecution of several of these applications. Patent Owner sought to supplement the specification by incorporating Fig. 1 of Frankoski into the disclosure, claiming that the new figure reflected the “preferred” embodiment of the alleged invention. But when the claims were rejected in view of Frankoski, Patent Owner went to great lengths to distinguish the alleged invention from Frankoski. Patent Owner’s actions shed important light on the nature and scope of the alleged invention.

### a. U.S. Appl. No. 10/871,911

U.S. Appl. No. 10/871,911 was filed on June 18, 2004 and issued on October 10, 2006, as U.S. Patent No. 7,118,794. Ex. 1027 (“the '794 patent”) at 1.

All the pending claims were rejected in an Office Action dated June 1, 2005. Ex. 1024 ('911 Appl. File Wrapper), at 52. Among other things, the claims were rejected as being anticipated by, or obvious in view of, Frankoski. In response to the rejection, Patent Owner amended claim 1 to require the claimed “wind resistant” layer be on the “rear surface of said shingle,” and argued Frankoski did not anticipate or render obvious the claims: “Frankoski does not disclose a scrim

on an outer surface of the shingle,” whereas “the scrim of the *instant invention* is on the *rear surface* of the shingle, having a front surface thereof adhered to the asphaltic material on the *rear surface* of the shingle, and the *rear surface* of the scrim being uncoated, to resist upward lift via wind.” *Id.* at 67–71 (emphases added). Patent Owner stated: “The invention of Frankoski is directed to how one makes a substrate; it has nothing to do with applying a layer of scrim on to the *rear surface* of a shingle to resist wind lift-up.” *Id.* at 72 (emphasis added).

The Examiner was apparently persuaded by Patent Owner’s arguments. The rejections based on Frankoski were withdrawn, and the application subsequently was allowed to issue. *See id.* at 119; *see also* Ex. 1003 at § III.G.2.

**b. U.S. Appl. No. 12/857,868**

U.S. Appl. No. 12/857,868, filed on August 17, 2010 claims to be a continuation of U.S. Application No. 12/422,506 (“the ’506 application”), which issued as U.S. Patent No. 7,781,046. Ex. 1034 (“the ’243 patent”), at 1. It issued on May 8, 2012, as U.S. Patent No. 8,173,243. *Id.*; Ex. 1003 at ¶ 235. As filed, the abstract reads as follows:

A laminated shingle and a method of making it is provided in which ***the rear surface of the shingle*** is provided with an attached reinforcement layer through which fasteners may be applied when the shingle is applied to a roof.

Ex. 1029 (’868 Appl. File Wrapper), at 23 (emphasis added). In a preliminary



amendment, new Fig. 4B was added. *Id.* at 52. The stated purpose was: to “incorporate subject matter . . . incorporated by reference in the specification.” *Id.* at 50. New Fig. 4B was presented as a photocopy of Fig. 1 from Frankoski, with hand-written annotations increasing the item numbers by 100. Ex. 1003 at ¶ 237.

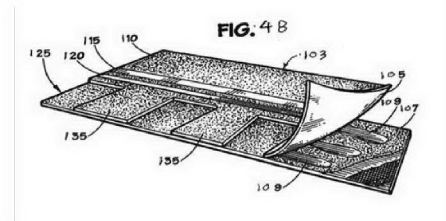

A new description corresponding to Fig. 4B was also added to the specification. Ex. 1034 (‘243 patent), at col. 4:40–49; *see* Ex. 1029 at 50-51. This passage is identical to the passage in Frankoski except for the re-numbering of the items and the introduction of a typographical error. Ex. 1003 at ¶¶ 238–42.

In the amended excerpt, Patent Owner stated that Fig. 4B showed “[t]he ***preferred laminated roofing shingle***” “***in accordance with the present invention.***” Ex. 1029 at 51 (emphasis added); Ex. 1034 at col. 4:40–41; Ex. 1003 at ¶ 243. This material is the only description of a laminated shingle contained in the specification.

In an office action dated October 15, 2010, all the pending claims were rejected in view of Frankoski. Ex. 1029 at 57. In the rejection, the Examiner indicated that the scrim 60 in Frankoski satisfied the “reinforcement second thickness layer” limitation required by the claims. *Id.* at 60–62; Ex. 1003 at ¶ 245.

In response, Patent Owner argued that the claimed reinforcement layer is located “on ‘said ***rear surface*** of said posterior layer of said shingle,’” whereas the reinforcement layer of Frankoski is shown “as being above the mat layer.” Ex. 1029 at 84 (emphasis added); Ex. 1003 at ¶¶ 246–47. Patent Owner also argued that, unlike the alleged invention, the reinforcement layer of Frankoski is embedded in the shingle: “While in Frankoski et al, the scrim may be either above or below the mat, ***it is nevertheless embedded in the shingle layer.***” Ex. 1029 at 84 (emphasis added); Ex. 1003 at ¶ 248.

Patent Owner argued that the position of the reinforcement layer on the rear surface of the shingle was critical: “the scrim appears ***on the rear*** of the posterior layer of the shingle and ***it is because of this*** that such provides the favorable force bending characteristics for the shingle shown in Fig. 4, that resist upward lifting due to wind conditions. This is different than applying a scrim inwardly of the shingle.” Ex. 1029 at 84–85 (emphases added); Ex. 1003 at ¶ 249.

When these arguments proved unsuccessful, Patent Owner appealed the rejections. Ex. 1029 at 117. In the summary of claimed subject matter in the appeal brief, Patent Owner stated: “A reinforcement layer is ***on the rear surface*** of the shingle.” *Id.* at 125–26 (emphasis added). Patent Owner also made other arguments emphasizing the reinforcement layer being adhered to the rear surface. *Id.* at 126-31; Ex. 1003 at ¶¶ 250–56. Ultimately, without any decision on the

appeal, the Examiner allowed the claims and the application issued as the '243 patent. Ex. 1029 at 180; Ex. 1003 at ¶ 257.

### **3. Effective Filing Date of the Claims**

For the purposes of this proceeding, Petitioner will assume that the effective filing date of claims 1–22 of the '876 patent is not earlier than November 6, 2002, the earliest filing date of any application to which the '876 patent claims priority. Ex. 1003 at ¶ 42.

#### **D. Person of Ordinary Skill in the Art**

The person of ordinary skill has a bachelor's degree, and potentially some advanced schooling, in chemistry, engineering (such as chemical, civil, or mechanical engineering), materials science, physical science, or a related discipline, and approximately 3–5 years of additional training and experience in the field of roofing materials and asphalt shingles. *Id.* at ¶ 41.

#### **E. Construction of Terms Used in the Claims**

In an IPR, claims must be given their broadest reasonable construction in light of the specification. 37 CFR § 42.100(b); M.P.E.P. § 2111.01.

In instituting *inter partes* review in the proceedings involving these related patents, *i.e.*, IPR Nos. 2014-01397, -01401, -01402, -01403, -01404, the Board determined that “no express claim construction is required for purposes” of the institution decisions. *E.g.*, IPR No. 2014-01397, Paper No. 12 (Mar. 9, 2015) at 6. To prevent any issue of waiver and because claim construction may be relevant to

rebutting Patent Owner's positions on secondary considerations, Petitioner sets forth below its construction of the claim terms, which are substantially the same constructions as set forth in the petitions in related proceedings. *Supra* at § I.C.2.

### 1. Elements (a)–(d) of Claim 1

As discussed in § III.A.1., the preamble and elements (a)–(d) of claim 1 describe nothing more than an “array” of the “basic” prior art asphalt shingle (made by methods considered “common practice” since at least the 1930s) attached to a roof in a conventional manner, *i.e.*, by fasteners in courses. As discussed in § III.B.1., the '876 patent itself acknowledges that the basic asphalt shingle was known. Ex. 1050 at col. 2:63–3:20; Ex. 1003 at ¶¶ 61–62, 291, 317–18. The preamble and elements (a)–(d) therefore encompass nothing more than an array of shingles applied to a roof in courses with fasteners, wherein an asphalt shingle is made of (i) a base layer of mat having front and rear surfaces, (ii) a coating of asphaltic material on both front and rear surfaces of the mat, and (iii) a coating of granular material on the asphaltic material on both front and rear surfaces, which combined together form a “first thickness layer.” Ex. 1003 at ¶¶ 291, 317–18.

### 2. “shingle”

Claim 1 uses the term “shingle” several times. “Shingle” is used, for example, in the preamble to describe the claimed product as a whole (*i.e.*, an array of shingles applied to a roof). “Shingle” also appears twice in element (e),

describing the location where the “reinforcement second thickness layer” is “adhered.” Ex. 1050 at col. 7:50–57; Ex. 1003 at ¶¶ 292, 317–18.

The use of the term “shingle” to describe both (1) the claimed shingle product as a whole and (2) the location where a component of the claimed product is “adhered” is internally inconsistent and raises questions as to claim scope. Ex. 1003 at ¶¶ 293, 317–18. For example, if the “reinforcement second thickness layer” is one component of the claimed “shingle,” while at the same time being adhered to the same “said shingle,” then one possibility, based on the literal reading of the claim, is that the “reinforcement second thickness layer” is adhered to itself. *Id.* This obviously makes no sense. *Id.*

This logical inconsistency is resolved only if different meanings are assigned to the term “shingle” depending on context. In the preamble, “shingle” clearly refers to the claimed shingle product as a whole, which includes a “reinforcement second thickness layer.” *Id.* at ¶¶ 294–95, 317–18. But in element (e), the “said shingle” cannot already include a “reinforcement second thickness layer” because it states that the “reinforcement second thickness layer” is “adhered to an exterior surface of said shingle.” *Id.* at ¶¶ 296, 317–18.

To make any sense of this otherwise illogical claim, the “shingle” in element (e) should be interpreted to mean the “first thickness layer” identified in element (c). Claim 1 requires a distinct “first thickness layer” and a distinct “reinforcement

second thickness layer.” *Id.* at ¶¶ 297–98, 317–18. The “first thickness layer” comprises “a base layer of mat,” “a coating of asphaltic material on both front and rear surfaces of the mat,” and “coatings of granular material on said both front and rear surfaces.” *Id.* at ¶¶ 298, 317–18. Because of the requirement for distinct first and second thickness layers, the only location to which the “reinforcement second thickness layer” may be adhered is the outside exterior surface (*i.e.*, “coatings of granular material”) of the first thickness layer. *Id.* at ¶¶ 299, 317–18.

Adhering the “reinforcement second thickness layer” to any other recited claim element (*e.g.*, the “base layer of mat”) would amount to inserting the “reinforcement second thickness layer” within the “first thickness layer,” thereby violating the claim requirement for distinct first and second thickness layers. *Id.* at ¶¶ 299, 317–18. Further, as explained in § III.C.2., when prosecuting related applications, Patent Owner repeatedly emphasized that the reinforcement layer of the alleged invention was not “embedded” within the shingle, and instead positioned on the outside surface of the shingle. The requirement that the “reinforcement second thickness layer” be adhered to the “exterior surface” is consistent with this understanding because the person of ordinary skill would understand that there is only one “exterior surface” described in the claim, *i.e.*, the granular surface of the “first thickness layer.” Ex. 1003 at ¶¶ 300, 317–18.

This understanding is also supported by the specification itself, which states

that, when the reinforcing layer is “adhered,” this is done by means of “an additional post-applied thin layer of asphaltic or non-asphaltic adhesive.” *Id.*; Ex. 1050 at col. 4:11–13. “Post-applied” would be understood to refer to a manufacturing step downstream of the steps in which asphalt and granular material are applied to the mat. Ex. 1003 at ¶¶ 301, 317–18. Figs. 2A, 4 and 4A are in accord as each shows the reinforcement layer as a distinct thickness layer. *Id.*

Thus, the meaning of the phrase “said shingle” to refer to the location where the “reinforcement second thickness layer” is “adhered” must be “first thickness layer,” such that the requirement for the “reinforcement second thickness layer” to be “adhered to an exterior surface of said shingle” means that it must be adhered to the exterior surface of the first thickness layer. *Id.* at ¶¶ 301, 317–18.

This construction is necessary to preserve the claim’s requirement for distinct first and second thickness layers notwithstanding the usage of the term “shingle” in the preamble to mean the finished product as a whole and would apply not only to the term “said shingle” in element (e) of claim 1, but also anywhere else where a description is being made of where or how the “second reinforcement thickness layer” is “adhered.” *Id.* at ¶¶ 302, 317-18.

### **3. “adhered to an exterior surface of said shingle”**

Claim 1 requires that the “reinforcement second thickness layer” be “adhered to an exterior surface of said shingle.” The specification of the ’876

patent describes how the “reinforcement second thickness layer” is “adhered.” *Id.* at ¶¶ 303, 317–18. Specifically, the patent states that the reinforcement layer is:

**either embedded** in the asphaltic layer on the rear of the shingle **or adhered** to the rear of the shingle by an additional post-applied thin layer of asphaltic or non-asphaltic adhesive. The reinforcement layer 29, 39, will be adhered to the rear surface 21, 31 of the shingles of this invention, by means of any suitable adhesive, such as a bitumen or the like, or any other adhesive.

Ex. 1050 at col. 4:10–16 (emphases added); Ex. 1003 at ¶¶ 304, 317–18.

A clear distinction is being drawn between an “embedded” reinforcement second layer and one that is “adhered.” Ex. 1003 at ¶¶ 305, 317–18. In fact, as discussed in § III.C.2., the inventors distinguished Frankoski on the basis that it disclosed an “embedded” reinforcement layer, while the claimed invention did not.

In general, the term “embedded” means that something is fixed into a surrounding mass, usually by mechanical or physical means. *See, e.g.*, Ex. 1039 American Heritage Dictionary, 4th Ed. (2000) (American Heritage 2000), at 4 (defining “embed” as “[t]o fix firmly in a surrounding mass”); Ex. 1003 at ¶¶ 306, 317–18. In the asphalt roofing industry, embedded material is material that is mechanically affixed into surrounding material, such as asphalt. Ex. 1003 at ¶¶ 306, 317–18. In other words, close physical contact and overlap between the materials results in attachment. *Id.*



“Adhered” generally means stuck together as if by glue or cement. *See, e.g.*, Ex. 1039 (American Heritage 2000), at 3 (defining “adhere” as “[t]o stick fast by or as if by suction or glue”); Ex. 1003 at ¶¶ 307, 317–18. Unlike “embedded” material, when materials are said to be “adhered,” attachment generally occurs via chemical interactions between the two materials, or between each of the materials and a separate adhesive, particularly in a context, such as in the ’876 patent, where a clear distinction is being drawn between “adhered” and “embedded.” *Id.* at ¶¶ 307, 317–18.

While no examples of “embedded” material are described in the patent, the patent does describe how the reinforcing layer is “adhered” to the shingle. *Id.* at ¶¶ 308, 317–18. The ’876 patent states that the reinforcement layer is adhered by an “additional” thin layer of asphalt or non-asphaltic adhesive. Ex. 1050 at col. 4:12–13. In other words, additional material is used as an adhesive. Ex. 1003 at ¶¶ 308, 317–18. The specification states the adhesive is “post-applied” meaning that it is applied at some point after the first thickness layer has been made, *i.e.*, after the mat has been coated with asphalt and covered with granular material. *Id.* at ¶¶ 309.

Further, the person of ordinary skill would understand the “reinforcement second thickness layer” is “adhered” to the rear surface of the “shingle,” *i.e.*, the “first thickness layer.” *Id.* at ¶¶ 310, 317–18. As discussed above, the clear focus of the invention is a reinforcing layer attached to the rear surface. *Supra* at

§ III.B.2. Not only does the specification describe the location of the reinforcement layer in the “present invention” as being on the rear surface, but it states that this location is critical to performance. *Id.* The prosecution history confirms that the reinforcement layer must be on the rear surface. *Supra* at § III.C. Thus, the broadest reasonable construction of “adhered to an exterior surface of said shingle” is “attached to the rear exterior surface of the first thickness layer by means of glue, cement, or some other chemical interaction between one or more materials.” Ex. 1003 at ¶¶ 311, 317–18.

#### 4. “substantially thinner”

The term “substantially thinner” is used to describe the “reinforcement second thickness layer,” but is not defined in the patent and does not carry with it a generally understood meaning in the field. *Id.* at ¶¶ 312, 317–18. Therefore, this term fails to “inform those skilled in the art about the scope of the invention with reasonable certainty.” *Nautilus, Inc. v. Biosig Instruments, Inc.*, 134 S. Ct. 2120, 2129–30 (2014).

While the specification and claims 8 and 21 of the ’876 patent state the “reinforcement second thickness layer” may be made of “a scrim” or of “thin fabric, plastic film, paper, parchment, [or] foil,” Ex. 1050 at col. 4:8–10, these materials can vary in thickness. Ex. 1003 at ¶¶ 313–14, 317–18. Thus, these examples shed no light on what “substantially thinner” means. *Id.*

The figures in the '876 patent confuse things further. *Id.* at ¶¶ 315-18. Fig. 4A shows that the reinforcement material 46 has a thickness that is substantial enough to cause a hump in the shingle when attached to a roof 40. *Id.* Fig. 2A shows the reinforcing layer 29 is nearly as thick as the main part of the shingle. *Id.*

For this proceeding, however, Petitioner will ignore this ambiguity and assume that any material made from woven or nonwoven thin fabric, plastic film, paper, parchment, foil, scrim, “or the like,” which the person of ordinary skill would understand could be fabricated to have a thickness smaller than a base shingle mat, meets the “substantially thinner” limitation of the claims. *Id.*

#### **IV. Precise Reasons for Relief Requested**

As discussed, the Board has already instituted *inter partes* review on patents related to the '876 patent. *See supra* at § I.C.2. At the time the petitions on those related patents had been filed, the '876 patent had not yet issued. As set forth in detail below, *inter partes* review should be instituted on the '876 patent for substantially the same reasons that trial was instituted on the related patents. *See also* Ex. 1003 at § VI.

For example, the claims of the '876 patent are substantively similar to the claims of the U.S. Patent No. 8,615,968 (“the '968 patent”) (Ex. 1038). Claims 1 and 10 of the '876 patent are nearly identical to claims 1 and 11 of the '968 patent, upon which *inter partes* review has already been instituted. The only difference is

that instead of limitation (f) of claims 1 and 11 of the '968 patent—which reads “said reinforcement second thickness layer extending at least partially lower than the fastening zone, toward the lower edge of the shingle or at least partially into the fastening zone toward the upper edge of the shingle”—element (e) of claims 1 and 10 of the '876 patent requires a reinforcing second thickness layer “being at least partially within said fastening zone.” Several of the dependent claims of the '876 patent are identical or contain only minor, insubstantial modifications to the claim language of the '968 patent. *Compare, e.g.*, claims 5, 6, 7 and 8 of the '876 patent, *with* claims 4, 2, 3, and 6 of the '968 patent. Thus, for the same reasons the Board correctly instituted *inter partes* review of claims 1–18 of the '968 patent in view of Venrick and Frankoski in IPR No. 2014-01404, it should institute review of claims 1–22 here. *See* IPR No. 2014-01404, Paper No. 10 (Mar. 9, 2015) at 12-13.

**A. Venrick 1939 (Ex. 1013) in View of Frankoski 1998 (Ex. 1010) Renders Obvious Claims 1-22**

U.S. Patent No. 2,161,440 to Venrick (Venrick) (Ex. 1013) issued on June 6, 1939 and is prior art under 35 U.S.C. § 102(b). U.S. Patent No. 5,822,943 to Frankoski (Frankoski) (Ex. 1010) issued on October 20, 1998 and is prior art under 35 U.S.C. § 102(b). The '876 patent refers to the laminated asphalt shingles described in Frankoski as the “basic” “prior art” shingle and incorporates by reference the disclosure of Frankoski. Ex. 1050 at col. 3:17–20; Ex. 1003 at ¶¶ 319, 345–46, 671.

**1. Venrick In View Of Frankoski Renders Obvious Claim 1**

The preamble of claim 1 and elements (a)–(d) of claim 1 describe nothing more than an array of basic asphalt shingles, installed on a roof in the conventional manner. Ex. 1003 at ¶¶ 57–58, 677. The ’876 patent identifies Frankoski as exemplary of these characteristics of a “basic” “prior art” shingle, Ex. 1050 at col. 3:17–20, and Frankoski teaches applying this shingle to a roof, Ex. 1010 at col. 2:62–67 (referring to “a roof constructed of such shingles” and “shingles in their final applied configuration”). Ex. 1003 at ¶¶ 671–72, 683.

The Board has already correctly instituted *inter partes* review with respect to the ’968 patent, which is related to the ’876 patent, finding that Venrick discloses the preamble and elements (a)–(d) of claim 1. *See* IPR No. 2014-01404, Paper No. 10 (Mar. 9, 2015) at 12.

Venrick describes a “fabricated shingle strip consisting of a base of fibrous material to which asphalt or similar plastic material is applied and which is surfaced with comminuted or granular material.” Ex. 1013 (Venrick), at 3, col. 1:1–7; col. 2:47–51. The base mat in Venrick would have been understood to have a front exterior surface and a rear exterior surface, a width defined by upper and lower edges, and a length defined by right and left edges. Ex. 1003 at ¶¶ 321, 678, 680–81. The disclosed shingle would also be understood to be “surfaced” *i.e.*, coated with asphalt on both sides of the mat and surfaced with granular material on

both sides, which was “common practice” since the 1930s. Ex. 1013 at 3, col. 1:1–7; col. 2:47–51; Ex. 1008 (Miller 1937), at 4, col. 1:13–24; Ex. 1003 at ¶¶ 322–23, 678, 681–82. The shingle is made of “shingle material.” Ex. 1003 at ¶ 678.

Venrick also discloses an array of shingles applied to a roof, by fasteners, in courses. Figs. 2 and 3 illustrate “the manner of laying the present shingles in overlapping relation on a roof.” Ex. 1013 at 3, col. 2:9–13. These figures depict an array of shingles applied to a roof in courses. Ex. 1003 at ¶ 679. Venrick also discloses the use of fasteners—nails—to apply the shingles to the roof. *Id.*; Ex. 1013 at 4, col. 2:6–10; *see id.* at 4, col. 2:12, Figs. 1, 3.

Thus, Venrick and Frankoski each teach all the limitations of the preamble of claim 1, as well as elements (a)-(c).

Venrick and Frankoski also disclose element (d), which is another component of the basic prior art asphalt shingle. The asphalt shingle in Venrick is shown to have a nailing/fastening zone that includes a number of “nail openings” (23 in Fig. 1) that extend longitudinally between the right and left edges and are located between or intermediate the upper and lower edges. Ex. 1003 at ¶¶ 324, 679. The nailing zone is also shown by the “nail openings” 47 in Fig. 8. *Id.* The fastening zone in Frankoski is shown as 20 in Fig. 1 and is found in the same general location. *Id.* at ¶¶ 349, 684.

Element (e) of claim 1 provides “an at least partially externally visible

generally longitudinal reinforcement second thickness layer of a substantially thinner dimension than said first thickness layer; said reinforcement second thickness layer being adhered to an exterior surface of said shingle, being at least partially within said fastening zone, and being at least substantially between right and left edges of the shingle.” Venrick in view of Frankoski render obvious this limitation. See IPR No. 2014-01404, Paper No. 10 (Mar. 9, 2015) at 12-13; see Ex. 1003 at ¶¶ 65–86.

Venrick teaches applying a reinforcement strip to, *inter alia*, strengthen and reinforce the shingle. Ex. 1013 at 3, col. 1:40–46; Ex. 1003 at ¶¶ 325–26; IPR No. 2014-01404, Paper No. 10 (Mar. 9, 2015) at 12-13. Fig. 1 of Venrick shows the reinforcing strip on the front of the shingle. Its overall location is nearly identical to the location of the reinforcement layer disclosed in the ’876 patent at Fig. 2, except in the ’876 patent, the strip is on the rear. Ex. 1003 at ¶¶ 327–28.

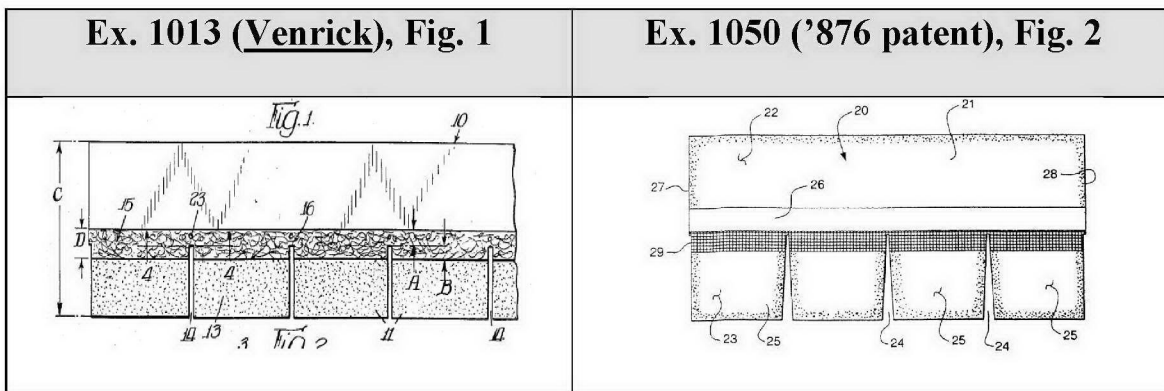

The reinforcing strip in Venrick can also be on the rear exterior surface of the shingle. See Ex. 1013 at Figs. 8–12; Ex. 1003 at ¶¶ 329, 686. Venrick states:

“in Figures 8, 10 and 12 the raised median strip is located on the undersurface of the shingle.” Ex. 1013 at 4, col. 2:60–62 (emphasis added); Ex. 1003 at ¶ 329.

As shown in Figs. 8–12 of Venrick, the reinforcing strip forms a partially externally visible second thickness layer that is generally longitudinal in orientation like the shingle itself and extends substantially between the right and left edges of the shingle. *See also* Ex. 1013 at 5, col. 1:26–28 (“said strip extends longitudinally of the shingle and accordingly reinforces and strengthens the same.”); Ex. 1003 at ¶¶ 330, 686. Venrick specifically contemplates that the reinforcing strip is applied to an exterior surface of the shingle after the manufacture of the shingle using an adhesive such as cement. Ex. 1013 at 4, col. 1:34–37 (“it is preferable to apply the strip 15 to the shingle after manufacture and thus said strip will be suitably cemented to the granule surfacing 13” (emphasis added)). Indeed, attachment in a “post-applied” fashion is preferred. *Id.* Venrick therefore shows that the reinforcing strip is a “second” thickness layer that is adhered to the first thickness layer, *i.e.*, the layer made of the base mat and asphalt/granule coatings. Ex. 1003 at ¶¶ 330, 686.

Notably, Venrick describes an embodiment in which the shingle tabs “lie flat.” Ex. 1013 at 5, col. 1:7-9; Ex. 1003 at ¶ 326. As depicted below, from the side view of both the shingle in Venrick and in the ’876 patent, the reinforcement layers in both appear substantially similar. Ex. 1003 at ¶ 324.

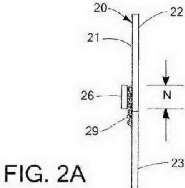

Ex. 1013 ( <u>Venrick</u> ), Fig. 9	Ex. 1050 ('876 patent), Fig. 2A
	

Venrick also explains that the reinforcing layer can be made of “felt, or metal . . . or layers of roofing tape suitably bonded together.” *Id.* at ¶¶ 333, 687; Ex. 1013 at 4, col. 2:73–5, col. 1:1. Frankoski shows a scrim layer 60 that reinforces the asphalt shingle. Scrim is the preferred reinforcing material in the '876 patent. *E.g.*, Ex. 1050 at col. 2:1-3, 3:27-39, 8:14-22. Ex. 1003 at ¶¶ 354, 687. The person of ordinary skill would have reasonably expected the thin scrim material in Frankoski to function as reinforcing material given the data in Frankoski showing that the scrim improved the strength of the asphalt shingle. Ex. 1003 at ¶¶ 357, 692 This is corroborated by other prior art such as Olszyk, which showed that thin material could be used for reinforcement, and that the material could be affixed to the rear surface. Ex. 1003 at ¶ 692; *supra* at §§ III.A.3.–4.

Given that the purpose of the scrim layer in Frankoski and the reinforcing strip in Venrick is reinforcement, the person of ordinary skill would have found it obvious to modify the asphalt shingle disclosed in Venrick with the scrim material of Frankoski. Ex. 1003 at ¶ 687. As the Board correctly stated in proceedings involving related patents, there are “rational underpinning[s] . . . to combine

Venrick and Frankoski.” *See* IPR No. 2014-01404, Paper No. 10 (Mar. 9, 2015) at

13. More specifically, the person of ordinary skill would have been motivated to make such a change with the understanding that the Frankoski scrim material is lighter and just as strong (if not stronger) than the materials disclosed in Venrick. Ex. 1003 at ¶¶ 688–89. *See Leapfrog Enterprises, Inc. v. Fisher-Price, Inc.*, 485 F.3d 1157, 1162 (Fed. Cir. 2007) (“adaptation of an old idea” “in order to gain the commonly understood benefits of such adaptation” is obvious). And Frankoski contemplates that the scrim layer can be positioned in any number of locations within the shingle. Ex. 1003 at ¶¶ 358, 688; Ex. 1010 at col. 3:39–45.

The scrim material in Frankoski would be understood to be much thinner than the asphalt and granule coated mat material that would make up the first thickness layer required by claim 1. Ex. 1003 at ¶¶ 354, 690. As in Venrick and other prior art such as Rohner and Sieling (*see supra* at § III.A.2.), the person of ordinary skill would recognize that the scrim material of Frankoski could be adhered to the rear exterior surface of the shingle as a second thickness layer. *Id.* at ¶ 690. To accomplish this, it would be understood that the scrim material could be adhered using, for example, a cement, such as that which is taught in Venrick. *Id.*; Ex. 1013 at 4, col. 1:32–37.

In IPR proceedings related to the ’876 patent (*see supra* at § I.C.2.), Patent Owner argued that the thin scrim in Frankoski would be inconsistent with the

aesthetic purposes of the reinforcing strip in Venrick. But this ignores the fact that Venrick explicitly contemplates a reinforcing function for the strip and that Venrick describes an embodiment in which the shingle tabs “lie flat,” as explained above. *See supra* at § III.A.2; Ex. 1003 at ¶ 691. Thus, in instituting IPR on these related patents, the Board correctly found that “Venrick teaches an additional purpose of its median strip, which is to provide a reinforcing strip to strengthen the upper ends of the openings between tabs to reduce the tendency of the shingle to tear...[w]e are persuaded...that this latter purpose would have given a person of ordinary skill a reason to use Frankoski’s scrim to make Venrick’s median strip.” IPR No. 2014-01397, Paper No. 12 (Mar. 9, 2015) at 13.

Finally, each reference teaches that the fasteners are applied through the reinforcement second thickness layer of the shingle, and thus the reinforcing layer is at least partially within the fastening zone. Ex. 1013 at 5, col. 1:51-56, Fig. 3; Ex. 1010 at col. 5:29-42; Ex. 1003 at ¶ 693. Venrick states the “shingles are nailed preferably about one inch above the upper ends of the tab defining openings and where the raised median strip is . . . .” Ex. 1013 at 5, col. 1:51–53. As shown by the hashed lines, the figures also show that the strip extends into the tab area (*i.e.*, towards the lower end of the shingle) and into the headlap area (*i.e.*, towards the upper edge of the shingle). Ex. 1003 at ¶ 693. Similarly, Frankoski contemplates a “partial size” scrim (*e.g.*, 6 inches wide) and states the scrim will “coincide with at

least a portion of the nail zone for the shingle and also extend into the shingle tab portions to provide added strength and increase the overall performance characteristics of the shingle.” Ex. 1010 at col. 5:29–42. Frankoski suggests that the reinforcing scrim can extend the full length and width of the shingle, which would necessarily meet this limitation. *Id.* at col. 5:28-29; Ex. 1003 at ¶ 693.

Thus Venrick in view of Frankoski renders obvious claim 1. Ex. 1003 at ¶ 694; *see id.* at §§ V.A., V.C., VIII.A., VIII.A.1.

## 2. Venrick In View Of Frankoski Renders Obvious Claim 10

Claim 10 is directed to a method of applying an array of shingles that is substantially identical to the array of shingles described in claim 1 of the patent. The shingle in the method of claim 10 differs in only two respects from the shingle of claim 1. First, claim 10 specifically requires coatings of granular material “on the asphaltic material,” which Venrick and Frankoski show and which was “common practice” since at least the 1930s. *Supra* at § III.A.1.-3.; Ex. 1003 at ¶ 716; *see* Ex. 1013 at 3, col. 1:4–7; Ex. 1010 at col. 1:11–15. Second, claim 10 adds new element (f) (“fastening the shingles to a roof, in courses”); as explained with respect to the preamble of claim 1, Venrick and Frankoski show what the person of ordinary skill would understand to be an array of shingles applied to a roof by fasteners in courses, as required by element (f). *See* Ex. 1010 at 2:62–67; Ex. 1003 at ¶ 717; *supra* at § IV.A.1. Therefore, for these reasons and all the

reasons provided for claim 1, Venrick in view of Frankoski renders obvious claim 10. Ex. 1003 at ¶ 718; *see id.* at § VIII.A.10.

**3. Venrick In View Of Frankoski Renders Obvious Claim 16**

Claim 16 is an independent claim directed to a shingle that is substantially identical to the array of shingles described in claim 1 of the patent. Thus, for the same reasons Venrick in view of Frankoski renders obvious each element of claim 1, the references render claim 16 obvious. *Id.* at § VIII.A.16.

**4. Venrick In View of Frankoski Renders Obvious Claim 22.**

Claim 22 is an independent claim directed to a shingle that is substantially identical to the shingle of claim 16, except that claim 22 is broader than claim 16. For example, claim 22 does not require the shingle have front and rear “exterior” surfaces or be “comprised of shingle material.” Nor does claim 22 require the second thickness layer be “at least partially externally visible” or adhered “to an exterior surface” of the shingle. Because Venrick in view of Frankoski render obvious claim 16, they also render obvious claim 22. *Id.* at § VIII.A.22.

**5. Venrick In View Of Frankoski Renders Obvious Claims 6 and 11**

Claims 6 and 11 are dependent on claims 1 and 10, respectively, and require a shingle that is “comprised of a single layer of shingle material with the front and rear surfaces being on opposite sides of the single layer of shingle material.” *Id.* at ¶¶ 702, 719. Venrick teaches such a single layer strip shingle. Ex. 1013 at 4, col.

1:3–9. The figures in Venrick show strip shingles, which were made of a single layer of shingle material with front and rear surfaces. *Id.* at ¶¶ 703, 720; *supra* at § III.A.2.; Ex. 1013 at Figs. 1, 8; Ex. 1005 at 4. Venrick in view of Frankoski therefore renders claims 6 and 11 obvious. Ex. 1003 at §§ VIII.A.6., VIII.A.11.

**6. Venrick In View Of Frankoski Renders Obvious Claim 7 and 14**

Claims 7 and 14 are dependent on claims 1 and 10, respectively, and require each shingle to have “two layers of shingle material laminated together,” “with the front and rear surfaces being on opposite sides of the shingle.” Claim 14 further adds “the step of laminating the at least two layers of shingle material together.” Venrick in view of Frankoski renders obvious these claims. Frankoski describes and illustrates “a two-ply laminated shingle.” Ex. 1003 at ¶¶ 708, 727; Ex. 1010 at col. 4:34, Fig. 1. And, as explained above in § III.A.4., two-ply laminated shingles were well known in the art. Ex. 1003 at ¶¶ 49-50, 706, 727; *see* Ex. 1005 at 4, Fig. 12; Ex. 1011 (Malarkey). The person of ordinary skill would understand that the reinforcing layer disclosed in Venrick and Frankoski would have applicability and the same beneficial results when used in all types of shingles, including the most common types of shingles such as laminated shingles. Ex. 1003 at ¶¶ 706-09, 727. The application of the reinforcement layer in Venrick and Frankoski to such a shingle would have been an obvious design choice given the popularity of laminated shingles, rendering obvious claims 7 and 14. *Id.*; *see id.* at §§ VIII.A.7.,

VIII.A.14.

7. **Venrick In View Of Frankoski Renders Obvious Claim 17**

Claim 17 depends from claim 16 and adds the additional requirement that the shingle “is comprised of at least two layers of shingle material laminated together, with the front and rear surfaces being on opposite sides of the shingle and wherein the at least two layers of shingle material comprise a top sheet and a backing sheet, with the top sheet including a plurality of alternating tabs and cut out portions along a lower longitudinal edge of the top sheet, with portions of the backing sheet being visible through the cutout portions being defined by edges of the tabs and with file cutout portions being of a plurality of longitudinal dimensions.” *Id.* at ¶¶ 733-35. As explained in § IV.A.6. with respect to claims 7 and 14, Frankoski describes and illustrates “a two-ply laminated shingle,” such shingles were well known in the art, and the application of the reinforcement layer in Venrick and Frankoski to such a shingle would have been an obvious design choice. Ex. 1003 at ¶¶ 706-09, 727. Laminated shingles exhibiting the claimed features were also known and common as evidenced by Figs. 2-2A of Bettoli 1975 (Ex. 1042) (depicting shingle with tabs and cutout portions being of a plurality of longitudinal dimensions; lower layer is visible through cutout portions in top layer that are defined by the edges of the tabs), Fig. 10 of Cash (Ex. 1005) (same) and ARMA Manual (Ex. 1009) at 12, Table 1 (same). Further, not only are shingles

with the described characteristics (*i.e.*, “alternating tab and cut out portions”) shown in Fig. 1 of Frankoski, but a shingle having these features is shown in Fig. 1 of the ’876 patent (Ex. 1050), which the patent describes as “prior art.” Ex. 1003 at ¶ 735. Claim 17 is thus obvious. *Id.* at ¶ 736; *see id.* at § VIII.A.17.

**8. Venrick In View Of Frankoski Renders Obvious Claim 20**

Claim 20 is dependent on claim 16, and requires “[a]n array of shingles . . . applied to a roof, in courses,” In addition to rendering claim 16 obvious, Venrick and Frankoski also render obvious claim 20 because each reference teaches “[a]n array of shingles . . . applied to a roof, in courses,” as explained above with respect to claim 1. *See supra* at § IV.A.1.; Ex. 1003 at § VIII.A.20.

**9. Venrick In View Of Frankoski Renders Obvious Claims 8 and 21**

Claims 8 and 21 are dependent on claims 1 and 16, respectively and require the “reinforcement second thickness layer comprises a material selected from the group consisting of: (i) thin fabric; (ii) plastic film; (iii) paper; (iv) parchment; (v) foil; and (vi) scrim.” Venrick in view of Frankoski renders obvious claims 8 and 21 because they both show a “reinforcement second thickness layer” comprising of the listed materials: Venrick discloses a reinforcement made from roofing tape (which was understood to be made from, among other things, paper) and Frankoski discloses a scrim reinforcement layer. *Supra* at § IV.A.1.; Ex. 1013 at 4, col. 2:74–75 (roofing tape); Ex. 1040 at 2, col. 2:90 (roofing tape made of paper); Ex. 1010



at Abstract, 3:29–30 (disclosing scrim); Ex. 1003 at §§ VIII.A.8., VIII.A.21.

**10. Venrick In View Of Frankoski Renders Obvious Claims 2, 5, 13 and 18**

Claims 2, 5, 13, and 18 are dependent on claims 1, 4, 12, and 16, respectively, and require a “reinforcement second thickness layer” that “extend[s] lower than the fastening zone, toward the lower edge of the shingle.” Venrick shows that the reinforcing strip extends lower than the nailing area, toward the lower edge of the shingle. *See also* Ex. 1003 at ¶¶ 695, 700, 724, 737. Figs. 8 and 9 of Venrick, for example, show that the reinforcing strip is on the back of the shingle and that the width of the strip extends at least partially into the area where the “nail openings” 47 are located. Venrick states the “shingles are nailed preferably about one inch above the upper ends of the tab defining openings and where the raised median strip is . . . .” Ex. 1013 at 5, col. 1:51–53. As shown by the hashed lines, the figures also show that the strip extends into the tab area (*i.e.*, towards the lower end of the shingle) and into the headlap area (*i.e.*, towards the upper edge of the shingle). Ex. 1003 at ¶¶ 331, 696, 701, 725, 739. Frankoski contemplates a “partial size” scrim (*e.g.*, 6 inches wide) and states the scrim will “coincide with at least a portion of the nail zone for the shingle and also extend into the shingle tab portions to provide added strength and increase the overall performance characteristics of the shingle.” *Id.* at ¶¶ 356, 696, 701, 725, 739; Ex. 1010 at col. 5:29–42. Frankoski suggests that the reinforcing scrim can extend the

full length and width of the shingle, which would necessarily meet this limitation.

*Id.* at col. 5:28–29. Venrick in view of Frankoski renders obvious claims 2, 5, 13, and 18. Ex. 1003 at §§ VIII.A.2., VIII.A.5., VIII.A.13., VIII.A.18.

**11. Venrick In View Of Frankoski Renders Obvious Claims 3, 4, 12, and 19**

Claims 3, 4, 12 and 19 are dependent on claims 2, 1, 10, and 16, respectively and require that “reinforcement second thickness layer is on the rear exterior surface of the shingle.” As discussed above in § IV.A.1., Venrick discloses a reinforcement layer that is adhered to the rear surface of the shingle. Venrick in view of Frankoski renders obvious claims 3, 4, and 12. Ex. 1003 at §§ VIII.A.3., VIII.A.4., VIII.A.12., VIII.A.19.

**12. Venrick In View Of Frankoski Renders Obvious Claims 9 and 15**

In addition to rendering obvious claims 1 and 10, Venrick and Frankoski also render obvious claims 9 and 15 because, as explained with respect to element (e) of claim 1, they each teach “fasteners applied through the reinforcement second thickness layers of the shingle, fastening the shingle to the roof.” *Supra* at § IV.A.1.; Ex. 1013 at 5, col. 1:51-56, Fig. 3; Ex. 1010 at col. 5:29–42; Ex. 1003 at ¶¶ 713–14, 729–30. In addition, the concept of nailing the shingle through the reinforced layers was also known and would have been obvious. *Id.* at ¶¶ 713–14, 729-30; *see id.* at §§ VIII.A.9., VIII.A.15.; *supra* at § III.A.2.

**B. Venrick 1939 (Ex. 1013) in View of Kiik 2001 (Ex. 1018) Renders Obvious Claims 1-22**

U.S. Patent Publication No. 2001/0055680 to Kiik (Kiik) (Ex. 1018) published on December 27, 2001 and is prior art under 35 U.S.C § 102(a).

The claims of the '876 patent are substantively similar to the claims of the '968 patent. *Supra* at § IV. Thus, for the same reasons the Board correctly instituted *inter partes* review of claims 1–18 of the '968 patent in view of Venrick and Kiik in IPR No. 2014-01404, it should institute review of claims 1–22 here. *See* IPR No. 2014-01404, Paper No. 10 (Mar. 9, 2015) at 14–16.

**1. Venrick In View Of Kiik Renders Obvious Claim 1**

As discussed at § IV., the Board has already correctly instituted *inter partes* review with respect to the '968 patent, which is related to the '876 patent, finding that Venrick discloses the preamble and elements (a) –(d) of claim 1. *See* IPR No. 2014-01404, Paper No. 10 (Mar. 9, 2015) at 11–12. Like Venrick, Kiik teaches the “basic” “prior art” asphalt shingle, Ex. 1018 at [0005], and shows what the person of ordinary skill would understand to be an array of such shingles applied to a roof by fasteners in courses, *id.* at [0003] (referring to “roofing materials on buildings, particularly the shingles on residential dwellings”). Ex. 1003 at ¶ 749. Venrick and Kiik disclose the preamble and elements (a)–(d) of claim 1.

Venrick and Kiik also disclose and render obvious element (e) of claim 1. Kiik discloses a “backing material” made of, among other things, polyester fibers,

nylon fibers, rayon fibers, acrylic fibers, polyolefin fibers, polypropylene fibers and recycled plastics fibers. Ex. 1018 at [0004]; Ex. 1003 at ¶¶ 383, 750–51.

The backing material in Kiik is “adhered to the face of the back of the shingle.” Ex. 1018 at [0007]. The purpose of the backing material in Kiik is reinforcement, *i.e.*, to provide the shingle with “better tear strength,” “pass impact tests despite their light product weight,” and provide “increased nail holding ability and maintain structural integrity at elevated temperatures.” *Id.* at [0009]; Ex. 1003 at ¶¶ 384, 752.

Kiik states the backing layer “may provide partial or full coverage” of the rear surface of the shingle and “enables the shingles to demonstrate enhanced physical properties.” Ex. 1018 at [0010]. Given that one of the purposes of the backing material is to improve “nail holding ability,” the person of ordinary skill would understand the backing material of Kiik extends at least partially into the nailing zone and is generally longitudinal, extending at least substantially between the right and left edges of the shingle. Ex. 1003 at ¶¶ 387, 753.

Venrick, like other prior art such as Rohner and Sieling, teaches a reinforcing layer that is adhered to the rear exterior surface as a second thickness layer. *Supra* at § III.A.2.; Ex. 1003 at ¶ 754. Given that the purpose of the backing material in Venrick and Kiik is reinforcement, the person of ordinary skill would have found it obvious to modify the asphalt shingle disclosed in Venrick by

using the Kiik backing material. *Id.*

Recognizing that the materials disclosed in Venrick are old, and that newer more state of the art materials have since been developed, the person of ordinary skill would have been motivated to make such a change with the understanding that the backing materials disclosed in Kiik are lighter and just as strong (if not stronger) than the materials disclosed in Venrick. *Id.* at ¶ 755.

The backing materials disclosed in Kiik are much thinner than the asphalt and granule coated mat material. *Id.* In fact, the exemplified backing material in Kiik, which was made of polyester fiber, had a thickness on the order of 1/1000<sup>th</sup> of an inch. *Id.* at ¶¶ 385, 755–56; Ex. 1018 at Table I.

Like Kiik, Venrick explicitly contemplates a reinforcing function for the strip and describes an embodiment in which the shingle tabs “lie flat,” as explained above. Ex. 1003 at ¶¶ 326, 758. As in Venrick and other prior art such as Rohner and Sieling, *see supra* at § III.A.2., the person of ordinary skill would recognize that the backing material of Kiik could be adhered to the rear exterior surface of the shingle as a second thickness layer, thereby making it visible. *Id.* at ¶ 757. To accomplish this, the person of ordinary skill would understand the backing material of Kiik could be adhered to the rear surface using, for example, a cement, such as what is disclosed in Venrick. *Id.* As the Board noted in instituting *inter partes* review for patents related to the ’876 patent, “a person of ordinary skill would have

attached Kiik's backing material over the conventional granular material on the outside surface of the base layer of mat, as Venrick does with its reinforcing strip.”  
*See* IPR No. 2014-01404, Paper No. 10 (Mar. 9, 2015) at 15.

The person of ordinary skill would have reasonably expected the thin backing material of Kiik to function as reinforcing material given the data in Kiik showing that the thin material improved the strength of the asphalt shingle and other prior art such as Olszyk and Frankoski (discussed *supra* at §§ III.A.3.-4.), which showed that thin material could be used as reinforcement material for asphalt shingles. Ex. 1003 at ¶ 759.

In IPR proceedings related to the '876 patent (*supra* at § I.C.2.), Patent Owner argued that the backing material in Kiik would not be combined with Venrick because Kiik's backing material is allegedly not rigid. Patent Owner also argued that Kiik taught away from coating the rear surface of the base layer of mat with granular material. The Board correctly found that “a person of ordinary skill in the art would have learned from Kiik that a reinforcement layer need not be completely rigid to serve as reinforcement, but can remain pliable, thereby achieving the additional benefit of being less susceptible to damage during hail storms.” *See* IPR No. 2014-01397, Paper No. 12 (Mar. 9, 2015) at 15. The Board also found that Kiik does not teach away from attaching its backing material over a granular coating “as it does not criticize, discredit, or otherwise discourage doing

so.” *Id.* at 16. The Board was correct in all of these findings. Ex. 1003 at ¶ 758.

Finally, Venrick in view of Kiik both teach that the reinforcing layer is at least partially within the fastening zone to enable improved nail pull strength. Ex. 1013 at 5, col. 1:51–56, Fig. 3; Ex. 1018 at [0009], [0010]. Figs. 8 and 9 of Venrick, for example, show that the reinforcing strip is on the back of the shingle and that the width of the strip extends at least partially into the area where the “nail openings” 47 are located. Venrick explicitly states the “shingles are nailed preferably ... where the raised median strip is [located]. . .” Ex. 1013 at 5, col. 1:51–56; Ex. 1003 at ¶¶ 331, 760. As shown by the hashed lines, the figures also show that the strip extends into the tab area (*i.e.*, towards the lower end of the shingle) and into the headlap area (*i.e.*, towards the upper edge of the shingle). Ex. 1003 at ¶ 332. Kiik also states the backing layer “may provide partial or ***full coverage***” and “enables the shingles to demonstrate enhanced physical properties,” thereby necessarily meeting limitation (f). Ex. 1018 at [0010] (emphasis added); Ex. 1003 at ¶¶ 387, 760. Therefore, Venrick in view of Kiik renders obvious claim 1. Ex. 1003 at ¶ 761; *see id.* at §§ V.A., V.G., VIII.B., VIII.B.1.

## 2. Venrick In View Of Kiik Renders Obvious Claim 10

Claim 10 is directed to a method of applying an array of shingles that is substantially identical to the array of shingles described in claim 1. The shingle in the method of claim 10 differs in only two ways from the shingle of claim 1. First,

claim 10 requires coatings of granular material “on the asphaltic material,” which is taught in Venrick and Kiik and was understood by the person of ordinary skill to have been “common practice” since at least the 1930s. *Supra* at § III.A.1.-3.; Ex. 1003 at ¶ 785; *see* Ex. 1013 at 3, col. 1:4–7; Ex 1018 at [0005]. Second, claim 10 adds new element (f) (“fastening the shingles to a roof, in courses”); as explained regarding the preamble of claim 1, Venrick and Kiik show this feature and it was well known in the prior art. *Supra* at § IV.B.1.; Ex. 1018 at [0003] (referring to “roofing materials on buildings, particularly the shingles on residential dwellings”); Ex. 1003 at ¶ 786. For these reasons and all the reasons provided for claim 1, Venrick in view of Kiik renders obvious claim 10. *Id.* at § VIII.B.10.

**3. Venrick In View of Kiik Renders Obvious Claim 16**

Claim 16 is directed to a shingle that is substantially identical to the array of shingles described in claim 1 of the patent. Thus, for the same reasons Venrick in view of Kiik renders obvious each element of claim 1, the references render claim 16 obvious. *Id.* at § VIII.B.16.

**4. Venrick In View of Kiik Renders Obvious Claim 22**

Claim 22 is directed to a shingle that is substantially identical to the shingle described in claim 1, except that claim 22 is broader than claim 16. For example, claim 22 does not require the shingle have front and rear “exterior” surfaces or be “comprised of shingle material.” Nor does claim 22 require the second thickness



layer be “at least partially externally visible” or adhered “to an exterior surface” of the shingle. Because Venrick in view of Kiik renders obvious claim 16, these references also render obvious claim 22. *Id.* at § VIII.B.22.

**5. Venrick In View Of Kiik Renders Obvious Claims 6 and 11**

Claims 6 and 11 are dependent on claims 1 and 10, respectively, and require a shingle that is “comprised of a single layer of shingle material with the front and rear surfaces being on opposite sides of the single layer of shingle material.” Ex. 1003 at ¶¶ 771, 788; Ex. 1018 at [0001], [0002]. Venrick teaches such a single layer strip shingle. Ex. 1013 at 4, col. 1:3–9. The figures in Venrick show strip shingles, which were made of a single layer of shingle material with front and rear surfaces. *Supra* at § III.A.2.; Ex. 1003 at ¶¶ 772, 789; Ex. 1013 at Figs. 1, 8; Ex. 1005 at 4. Venrick in view of Kiik therefore renders claims 6 and 11 obvious. Ex. 1003 at §§ VIII.B.6. and VIII.B.11.

**6. Venrick In View Of Kiik Renders Obvious Claims 7 and 14**

Claims 7 and 14 are dependent on claims 1 and 10, respectively, and require each shingle to have “two layers of shingle material laminated together, with the front and rear surfaces being on opposite sides of the shingle.” Claim 14 further adds “the step of laminating the at least two layers of shingle material together.” Venrick in view of Kiik renders obvious these claims. Kiik describes and illustrates “a standard laminated shingle product sold by Elk.” Ex. 1003 at ¶¶ 777,

796; Ex. 1018 at [0014]. The backing layer in Kiik is attached to this two-ply laminated shingle in the examples found in the reference. *Id.* As explained in § III.A.4., two-ply laminated shingles were well known. Ex. 1003 at ¶¶ 49–50, 774, 796; *see, e.g.*, Ex. 1005, at 4, Fig. 12; Ex. 1011 (Malarkey). The person of ordinary skill would understand the reinforcing layer disclosed in Venrick and Kiik would have applicability and the same beneficial results when used in all types of shingles, including the most common types of shingles such as laminated shingles. Ex. 1003 at ¶¶ 774–77, 796. The application of the reinforcement layer in Venrick and Kiik to such a shingle would have been an obvious design choice given the popularity of laminated shingles. *Id.* Thus, Venrick in view of Kiik renders obvious claims 7 and 14. *Id.* at §§ VIII.B.7., VIII.B.14.

**7. Venrick In View Of Kiik Renders Obvious Claim 17**

Claim 17 depends from claim 16 and adds the additional requirement that the shingle “is comprised of at least two layers of shingle material laminated together, with the front and rear surfaces being on opposite sides of the shingle and wherein the at least two layers of shingle material comprise a top sheet and a backing sheet, with the top sheet including a plurality of alternating tabs and cut out portions along a lower longitudinal edge of the top sheet, with portions of the backing sheet being visible through the cutout portions being defined by edges of the tabs and with file cutout portions being of a plurality of longitudinal

dimensions.” *Id.* at ¶¶ 802–04. As explained in § IV.B.6. with respect to claims 7 and 14, Kiik describes a standard two-ply laminated shingle and attaches a backing layer to such a shingle for reinforcement. Further, two-ply laminated shingles were well known, and the application of the reinforcement layer in Venrick and Kiik to such a shingle would have been an obvious design choice. Ex. 1003 at ¶¶ 774–77, 796. Laminated shingles exhibiting the claimed features of element (g) were also known and common as evidenced by Figs. 2-2A of Bettoli 1975 (Ex. 1042) (depicting shingle with tabs and cutout portions being of a plurality of longitudinal dimensions; lower layer is visible through cutout portions in top layer that are defined by the edges of the tabs), Fig. 12 of Cash (Ex. 1005) (same), and ARMA Manual (Ex. 1009) at 12, Table 1 (same). A shingle having the described features (*i.e.*, “alternating tab and cut out portions”) is also shown in Fig. 1 of the ’876 patent (Ex. 1050), which the patent describes as “prior art.” Ex. 1003 at ¶ 805. Claim 17 is thus obvious. *Id.* at § VIII.B.17.

**8. Venrick In View Of Kiik Renders Obvious Claim 20**

Claim 20 is dependent on claim 16 and requires “[a]n array of shingles according to claim 16, applied to a roof in courses.” In addition to rendering claim 16 obvious, Venrick and Kiik also render obvious claim 20 because each reference teaches “[a]n array of shingles . . . applied to a roof, in courses,” as explained above with respect to claim 1. *See supra* at § IV.B.1.; Ex. 1003 at § VIII.B.20.

**9. Venrick In View Of Kiik Renders Obvious Claims 8 and 21**

Claims 8 and 21 are dependent on claims 1 and 16 and require that a “reinforcement second thickness layer comprises a material selected from the group consisting of: (i) thin fabric; (ii) plastic film; (iii) paper; (iv) parchment; (v) foil; and (vi) scrim.” In addition to rendering obvious claims 1 and 16, Venrick in view of Kiik renders obvious claims 8 and 21 because they teach a “reinforcement second thickness layer” comprising of one of the group of materials in claims 8 and 21: Venrick describes roofing tape, which was understood to be made of paper and Kiik describes the use, among other things, of cotton and wool fibers, which the person of ordinary skill would understand could be woven into thin fabric; Kiik also describes a “woven polyester mat.” Ex. 1013 at 4, col. 2:74–75; Ex. 1040, at 2, col. 2:90; Ex. 1018 at [0004], [0006]; Ex. 1003 at §§ VIII.B.8., VIII.B.21.

**10. Venrick In View Of Kiik Renders Obvious Claims 2, 5, 13, and 18**

Claims 2, 5, 13, and 18 are dependent on claims 1, 4, 12, and 16, respectively, and require a “reinforcement second thickness layer” that “extend[s] lower than the fastening zone, toward the lower edge of the shingle.” Venrick shows the reinforcing strip extends lower than the nailing area, toward the lower edge of the shingle. Figs. 8 and 9 of Venrick, for example, show that the reinforcing strip is on the back of the shingle and that the width of the strip extends at least partially into the area where the “nail openings” 47 are located. Venrick

explicitly states the “shingles are nailed preferably ... where the raised median strip is [located]. . .” Ex. 1013 at 5, col. 1:51–56; Ex. 1003 at ¶¶ 331, 762, 769, 794, 807. As shown by the hashed lines, the figures also show that the strip extends into the tab area (*i.e.*, towards the lower end of the shingle) and into the headlap area (*i.e.*, towards the upper edge of the shingle). *Id.* Kiik also states the backing layer “may provide partial or ***full coverage***” and “enables the shingles to demonstrate enhanced physical properties,” thereby necessarily meeting limitation (f). Ex. 1018 at [0010] (emphasis added); Ex. 1003 at ¶¶ 387, 762, 769, 794, 807. Such a configuration would be obvious given the purpose of increasing nail pull strength, as described in Venrick and Kiik. *Id.* at ¶¶ 762, 769, 794, 807. Claims 2, 5, 13 and 18 are obvious. *Id.* at §§ VIII.B.2., VIII.B.5., VIII.B.13., VIII.B.18.

**11. Venrick In View Of Kiik Renders Obvious Claims 3, 4, 12, and 19**

Claims 3, 4, 12, and 19 are dependent on claims 2, 1, 10, and 16, respectively, and require that “the reinforcement second thickness layer is on the rear exterior surface of the shingle.” Venrick discloses a reinforcement layer that is adhered to the exterior rear of the surface. *Supra* at § IV.B.1. Similarly, Kiik discloses a backing layer that “may provide partial or full coverage” of the rear surface of the shingle. Ex. 1018 at [0010]. Thus, Venrick in view of Kiik render obvious claims 3, 4, and 12 because they both teach “the reinforcement second thickness layer” that “is on the rear exterior of the shingle.” Ex. 1003 at §§

VIII.B.3., VIII.B.4., VIII.B.12.

**12. Venrick In View Of Kiik Renders Obvious Claims 9 and 15**

Claims 9 and 15 are dependent on claims 1 and 10, respectively, and require “fasteners applied through the reinforcement second thickness layers of the shingle, fastening the shingles to the roof”. Venrick and Kiik render obvious claims 9 and 15 because, as explained with respect to element (e) of claim 1, both references disclose Ex. 1013 at 5, col. 1:51–56 (“The shingles are nailed preferably about one inch above the upper ends of the tab . . . where the raised median strip is...”), Fig. 3; Ex. 1018 at p. 2 [0009], [0010]. The nail pull data in Kiik, described in § III.A.3., confirms that nails applied to the shingle in Kiik passed through the “backing material.” Ex. 1003 at ¶¶ 781–82, 798–99. And, the concept of nailing the shingle through the reinforced layers was known, and such a configuration would have been obvious given the purpose of increasing nail pull strength described in Venrick and Kiik. *Supra* at § IV.B.1.; Ex. 1003 at ¶¶ 781–82, 798–99. Thus, claims 9 and 15 are obvious. Ex. 1003 at §§ VIII.B.9., VIII.B.15.

**C. Secondary Considerations Do Not Favor Nonobviousness**

To the extent that Patent Owner argues that the commercial success of Petitioner’s products bears on the question of the obviousness of the claims of the ’876 patent, Petitioner responds as follows: Petitioner’s products do not have a nexus to the claims of the ’876 patent because the products fall outside the scope of

the claims. Ex. 1003 at ¶¶ 814–17. Among other reasons, the claims require that the “second reinforcement thickness layer” be adhered to the “first thickness layer,” *i.e.*, the layer comprising the base mat coated with asphalt and granules. *Id.* at ¶ 817. But any reinforcement layer on Petitioner’s products is embedded directly to the asphalt as opposed to the “first thickness layer.” *Id.* In addition, to the extent that Patent Owner attempts to rely on Petitioner’s products that incorporate a SureNail® strip, such reliance is further misplaced because that feature is on the front of the shingle, not the rear surface as required by all claims of the ’876 patent, as properly construed. *Id.* To the extent that Patent Owner attempts to rely on Petitioner’s products that incorporate the WeatherGuard® feature for purposes of secondary considerations, such reliance is further misplaced for two reasons: first, the WeatherGuard® features is on only a portion of Petitioner’s products and second, the WeatherGuard® feature does not overlap the nailing zone of Petitioner’s shingle products. *Id.*

Even if Petitioner’s products were covered by the claims of the ’876 patent (and they are not), their commercial success is not attributable to the subject matter of the claims. A variety of different factors drive the decision to purchase a particular shingle. *Id.* at ¶ 819. These factors include cost, color, shape, ease of installation, warranty, and dollars spent marketing the product. To the extent consumers purchase Petitioner’s products, those sales would be driven by all of

these factors. *Id.*

In fact, the primary reason consumers purchase Petitioner's product is because it is an asphalt shingle. *Id.* at ¶ 820. The basic asphalt shingle, however, has been known for decades. Even if it is alleged that Petitioner's products include a "reinforcement second thickness layer" that meets all the limitations of the claims, this feature was also known for decades. *Id.* Thus, any commercial success enjoyed by Petitioner's products are not relevant. *Gnosis S.P.A. v. South Alabama Med. Sci. Found.*, IPR No. 2013-00116, Paper No. 68 (PTAB June 20, 2014) at 32-42 ("[A] showing of nexus ... involves establishing that novel elements in the claim, not prior-art elements, account for the objective evidence put forward to show nonobviousness."). Ultimately, Patent Owner bears the burden of proving secondary considerations. If Patent Owner sets forth evidence, Petitioner reserves the right to respond with additional evidence and argument.

## V. CONCLUSION

For the foregoing reasons, the Petitioner respectfully requests that Trial be instituted and that claims 1–22 of the '876 patent be canceled.

Dated: May 11, 2015

Respectfully Submitted,

/Jeffrey P. Kushan/  
Jeffrey P. Kushan  
Registration No. 43,401  
Sidley Austin LLP  
1501 K Street NW  
Washington, DC 20005



**PETITION FOR INTER PARTES REVIEW**  
**OF U.S. PATENT NO. 8,950,876**

**Attachment A:**  
**Proof of Service of the Petition**

## CERTIFICATE OF SERVICE

I hereby certify that on this 11th day of May, 2015, a copy of **Petition for *Inter Partes* Review** has been served in its entirety by Federal Express on the following counsel of record for patent owner:

Mehran Arjomand  
MORRISON & FOERSTER LLP  
707 Wilshire Blvd.  
Suite 6000  
Los Angeles, California 90017-3543  
Tel: (213) 892-5630  
Fax: (213) 892-5454  
E-mail: [marjomand@mofo.com](mailto:marjomand@mofo.com)

Amy R. Motomura  
MORRISON & FOERSTER LLP  
755 Page Mill Road  
Palo Alto, California 94304-1018  
Tel: (650) 813-5600  
Fax: (650) 494-0792  
E-mail: [amotomura@mofo.com](mailto:amotomura@mofo.com)

Stephen C. Jones  
MORRISON & FOERSTER LLP  
707 Wilshire Blvd.  
Suite 6000  
Los Angeles, California 90017-3543  
Tel: (213) 892-5907  
Fax: (213) 892-5454  
E-mail: [sjones@mofo.com](mailto:sjones@mofo.com)

Harold J. McElhinny  
MORRISON & FOERSTER LLP  
425 Market Street  
San Francisco, California 94105  
Tel: (415) 268-7265  
Fax: (415) 268-7522  
E-mail: [hmcElhinny@mofo.com](mailto:hmcElhinny@mofo.com)

Jack W. Londen  
MORRISON & FOERSTER LLP  
425 Market Street  
San Francisco, California 94105  
Tel: (415) 268-7415  
Fax: (415) 268-7522  
E-mail: [jlonden@mofo.com](mailto:jlonden@mofo.com)

Daniel P. Muino  
MORRISON & FOERSTER LLP  
2000 Pennsylvania Ave.  
Suite 6000  
Washington, D.C. 20006  
Tel: (202) 887-1501  
Fax: (202) 887-0763  
E-mail: [dmuino@mofo.com](mailto:dmuino@mofo.com)

John Child, Jr.  
PAUL AND PAUL  
1717 Arch Street  
Three Logan Square  
SUITE 3740  
PHILADELPHIA PA 19103  
Tel: (215) 568-4900

James McConnon  
PAUL AND PAUL  
1717 Arch Street  
Three Logan Square  
SUITE 3740  
PHILADELPHIA PA 19103  
Tel: (215) 568-4900

Ourmazed Ojan  
PAUL AND PAUL  
1717 Arch Street  
Three Logan Square  
SUITE 3740  
PHILADELPHIA PA 19103  
Tel: (215) 568-4900

Alex Sluzas  
PAUL AND PAUL  
1717 Arch Street  
Three Logan Square  
SUITE 3740  
PHILADELPHIA PA 19103  
Tel: (215) 568-4900

Jack B. Blumenfeld  
MORRIS, NICHOLS, ARSHT  
&TUNNELL LLP  
1201 North Market Street  
16<sup>th</sup> Floor  
P.O. Box 1347  
Wilmington, DE 19899  
Tel: (302) 658-9200  
E-mail: [jblumenfeld@mnat.com](mailto:jblumenfeld@mnat.com)

Dated: May 11, 2015

Respectfully submitted,

/Jeffrey P. Kushan/  
Jeffrey P. Kushan  
Registration No. 43,401  
*Attorneys for Petitioner*

**PETITION FOR INTER PARTES REVIEW**

**OF U.S. PATENT NO. 8,950,876**

**Attachment B:**

**List of Evidence and Exhibits Relied Upon in Petition**

## Appendix B

Exhibit #	Reference Name
1001	U.S. Patent No. 7,781,046
1002	U.S. Patent No. 7,781,046 File Wrapper (U.S. Application No. 12/422,506) (filed April 13, 2009)
1003	Declaration of Michael L. Bryson
1004	Curriculum Vitae of Michael L. Bryson
1005	Cash, <i>Asphalt Roofing Shingles</i> , Proc. 11 <sup>th</sup> Conf. Roofing Tech. 1-9 (Sept. 21–22, 1995)
1006	U.S. Patent No. 3,998,685
1007	Noone et al., <i>Asphalt-Shingles – A Century of Success and Improvement</i> , Proc. 11 <sup>th</sup> Conf. Roofing Tech. 23-33 (Apr. 22–23, 1993)
1008	U.S. Patent No. 2,099,131
1009	<i>ARMA Residential Roofing Manual</i> (1997)
1010	U.S. Patent No. 5,822,943
1011	U.S. Patent No. 6,145,265
1012	U.S. Patent No. 2,197,972
1013	U.S. Patent No. 2,876,440
1014	U.S. Patent No. 3,813,280
1015	U.S. Patent No. 4,876,321
1016	U.S. Patent No. 5,860,263
1017	U.S. Patent No. 6,228,785
1018	U.S. Patent Publication No. 2001/0055680
1019	U.S. Patent No. 6,341,462

Exhibit #	Reference Name
1020	U.S. Patent No. 5,577,361
1021	U.S. Patent No. 6,397,556
1022	U.S. Patent No. 5,571,596
1023	U.S. Application No. 11/421,893 (filed on June 2, 2006)
1024	U.S. Application No. 10/871,911 (filed on June 18, 2004)
1025	U.S. Application No. 10/288,747 (filed on November 6, 2002)
1026	U.S. Patent No. 6,758,019
1027	U.S. Patent No. 7,118,794
1028	U.S. Patent No. 7,537,820
1029	U.S. Application No. 12,857,868 (filed on August 17, 2010)
1030	U.S. Application No. 13/291,234 (filed on November 8, 2011)
1031	U.S. Application No. 13/462,159 (filed on May 2, 2012)
1032	U.S. Application No. 13/788,029 (filed on March 7, 2013)
1033	U.S. Application No. 13/855,820 (filed on April 3, 2013)
1034	U.S. Patent No. 8,173,243
1035	U.S. Patent No. 8,383,228
1036	U.S. Patent No. 8,409,689
1037	U.S. Patent No. 8,592,025
1038	U.S. Patent No. 8,615,968
1039	The American Heritage Dictionary of the English Language, 4th Ed. (2000), pp. 21, 583, 1472

Exhibit #	Reference Name
1040	U.S. Patent No. 1,524,090
1041	U.S. Patent No. 5,052,162
1042	U.S. Patent No. 3,921,358
1043	Consumer Reports Rating the Supermarkets – Shingles and siding , pp. 26-30 (Aug. 1997)
1044	ASTM, Standard Specification for Asphalt Shingles Made from Glass Felt and Surfaced with Mineral Granules (D 3462-02) (published March 2002), pp. 876-165
1045	Complaint, <i>CertainTeed Corp. v. Owens Corning</i> , Civ. A. No. 1:14-cv-00510-SLR (D. Del.)
1046	U.S. Patent No. 8,950,161
1047	U.S. Patent No. 8,950,161 File Wrapper (U.S. Application No. 14/068,306) (filed October 31, 2013)
1048	U.S. Patent No. 8,959,875
1049	U.S. Patent No. 8,959,875 File Wrapper (U.S. Application No. 14/284,492) (filed May 22, 2014)
1050	U.S. Patent No. 8,959,876
1051	U.S. Patent No. 8,959,876 File Wrapper (U.S. Application No. 14/307,677) (filed June 18, 2014)