

| | | |
|---|------------------|--|
| <p>(51) International Patent Classification 5 : H04B 1/50</p> | <p>A1</p> | <p>(11) International Publication Number: WO 93/16530 (43) International Publication Date: 19 August 1993 (19.08.93)</p> |
| <p>(21) International Application Number: PCT/FI93/00047 (22) International Filing Date: 12 February 1993 (12.02.93) (30) Priority data: 920645 14 February 1992 (14.02.92) FI (71) Applicant (for all designated States except US): NOKIA TELECOMMUNICATIONS OY [FI/FI]; Mäkkylän puistotie 1, SF-02600 Espoo (FI). (72) Inventor; and (75) Inventor/Applicant (for US only) : YLIKOTILA, Taavi [FI/FI]; Niinimäenkatu 4, SF-44120 Äänekoski (FI). (74) Agent: OY KOLSTER AB; Stora Robertsgatan 23, P.O. Box 148, SF-00121 Helsinki (FI).</p> | | <p>(81) Designated States: AU, GB, JP, NO, US, European patent (AT, BE, CH, DE, DK, ES, FR, GB, GR, IE, IT, LU, MC, NL, PT, SE). Published <i>With international search report. Before the expiration of the time limit for amending the claims and to be republished in the event of the receipt of amendments.</i></p> |

(54) Title: RADIO DEVICE

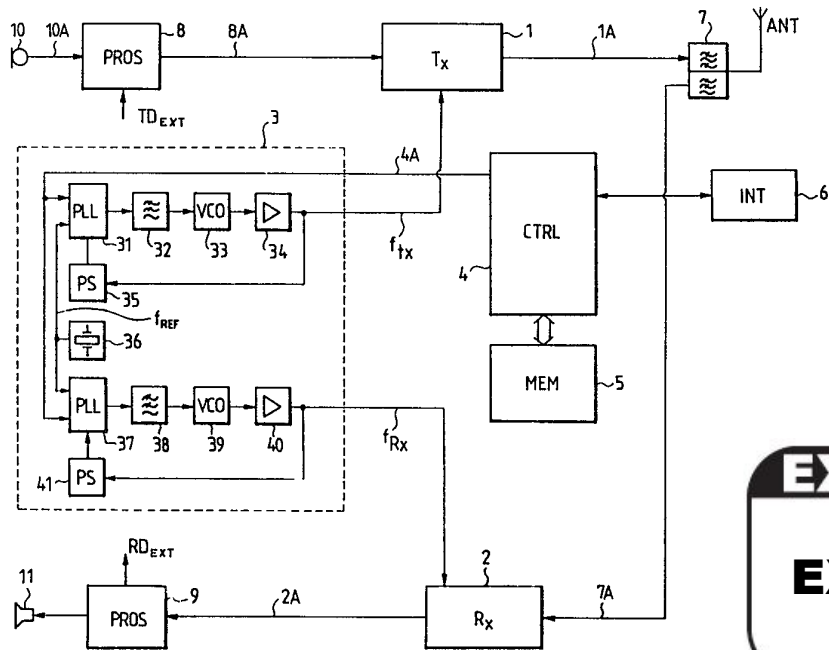

EXHIBIT
EX. 1019

(57) Abstract

The invention relates to a radio device for operation in at least two different radio systems having unequal bands of operating frequencies represented by channels numbers. The device comprises a radio transmitter (1); a radio receiver (2); a frequency synthesizer (3) for generating local oscillator frequencies for the radio transmitter and radio receiver; respectively and a control means (4, 5) for controlling the frequency synthesizer (3) so as to look it to transmitting and receiving frequencies corresponding to a selected channel number. In the invention, the control means comprises a memory (5) for storing frequency synthesizer control data of a single channel number for each different radio system, on the basis of which control data the control means is capable of deriving control data of any other channel number for the radio system in which the radio device is currently operating.

FOR THE PURPOSES OF INFORMATION ONLY

Codes used to identify States party to the PCT on the front pages of pamphlets publishing international applications under the PCT.

| | | | | | |
|----|--------------------------|----|--|----|--------------------------|
| AT | Austria | FR | France | MR | Mauritania |
| AU | Australia | GA | Gabon | MW | Malawi |
| BB | Barbados | GB | United Kingdom | NL | Netherlands |
| BE | Belgium | GN | Guinea | NO | Norway |
| BF | Burkina Faso | GR | Greece | NZ | New Zealand |
| BG | Bulgaria | HU | Hungary | PL | Poland |
| BJ | Benin | IE | Ireland | PT | Portugal |
| BR | Brazil | IT | Italy | RO | Romania |
| CA | Canada | JP | Japan | RU | Russian Federation |
| CF | Central African Republic | KP | Democratic People's Republic of Korea | SD | Sudan |
| CG | Congo | KR | Republic of Korea | SE | Sweden |
| CH | Switzerland | KZ | Kazakhstan | SK | Slovak Republic |
| CI | Côte d'Ivoire | LJ | Liechtenstein | SN | Senegal |
| CM | Cameroon | LK | Sri Lanka | SU | Soviet Union |
| CS | Czechoslovakia | LU | Luxembourg | TD | Chad |
| CZ | Czech Republic | MC | Monaco | TG | Togo |
| DE | Germany | MG | Madagascar | UA | Ukraine |
| DK | Denmark | ML | Mali | US | United States of America |
| ES | Spain | MN | Mongolia | VN | Viet Nam |
| FI | Finland | | | | |

Radio device

Field of the Invention

The invention relates to a radio device for operation in at least two different radio systems having unequal bands of operating frequencies represented by channel numbers, the radio device comprising a radio transmitter; a radio receiver; a frequency synthesizer means for generating local oscillator frequencies for the radio transmitter and the radio receiver, respectively; and a control means for controlling the frequency synthesizer means so as to lock the synthesizer means to transmitting and receiving frequencies corresponding to a selected channel number.

Background of the Invention

In private automatic mobile radio networks or trunked networks, several user groups or even several user organizations share the same radio channels and other resources in a common network. Typical private radio network applications include energy production and distribution, communal and municipal services, transportation, construction, maintenance, and emergency services, such as police, fire alarm and ambulance. A private mobile radio network may offer fast access within the user's own organization, individual or group communication, data communication, etc. The system checks the subscriber authorization and allocates resources. An individual subscriber is unaware that he uses the same frequencies as other subscribers as the system automatically selects a free radio channel for a call during the call set-up. This kind of radio telephone systems usually have a rather limited geographical coverage, and so

the user may easily get outside the service area of his own system, and thus cannot use his radio telephone. Therefore there has arisen a need to be able to use the same radio telephone in several different systems.

The specifications MPT 1327 and MPT 1343 issued by the British Ministry of Trade and Industry have become kind of *de facto* standards in Europe for private mobile radio networks. MPT 1327 specifies signalling over the radio path, while MPT 1343 specifies the operation and structure of the radio telephone. Systems complying with these specifications have been and will be introduced in different European countries. All radio telephones used in the different systems actually comply with the same MPT 1343 specification, wherefore they can, in principle, be transferred from one radio telephone network to another by varying the network-specific radio telephone parameters complying with the MPT 1343.

The radio telephone systems usually employ special radio channel numbers in all internal signalling for representing transmitting and receiving frequencies, i.e. radio channels, each channel number representing a certain pair of transmitting and receiving frequencies. A radio telephone or a similar radio device used in this kind of system converts each channel number internally into corresponding frequency synthesizer control data which controls the frequency synthesizer so as to cause it to be locked to the transmitting and receiving frequency pair corresponding to the channel number in the current radio system. When using the same radio telephone in different radio telephone networks, problems may be caused by the fact that a certain channel number, e.g. channel 1, may correspond to different fre-

quencies in different radio telephone systems, as illustrated in Figure 1. In Figure 1, the frequency of the channel CHO of the radio telephone system A is 410 MHz, while higher frequencies at intervals of 12.5 kHz or 25 kHz correspond to the other channel numbers. The channel numbering of the system B in turn is such that the frequency corresponding to the channel CHO is 420 MHz. As a consequence, the radio telephone cannot operate in both systems A and B as the channel numberings and frequency bands of the systems do not match.

Disclosure of the Invention

The object of the invention is to provide a radio device which is capable of operating in different radio networks where the channel numberings and frequency bands do not correspond to each other.

This is achieved by means of a radio device of the type described in the introductory chapter, which according to the invention is characterized in that the control means comprises a memory means for storing frequency synthesizer control data of a single channel number for each different radio system, on the basis of which control data the control means is capable of deriving control data of any other channel number for the radio system in which the radio device is currently operating.

The basic idea of the invention is that frequency synthesizer control data corresponding to a single channel number is stored in the radio device for each different radio system. The stored control data determines the physical frequency corresponding to said one channel number, and corresponding control data for the other channel numbers in the system are derived therefrom. An advantage of the invention is

Explore Litigation Insights

Docket Alarm provides insights to develop a more informed litigation strategy and the peace of mind of knowing you're on top of things.

Real-Time Litigation Alerts



Keep your litigation team up-to-date with **real-time alerts** and advanced team management tools built for the enterprise, all while greatly reducing PACER spend.

Our comprehensive service means we can handle Federal, State, and Administrative courts across the country.

Advanced Docket Research



With over 230 million records, Docket Alarm's cloud-native docket research platform finds what other services can't. Coverage includes Federal, State, plus PTAB, TTAB, ITC and NLRB decisions, all in one place.

Identify arguments that have been successful in the past with full text, pinpoint searching. Link to case law cited within any court document via Fastcase.

Analytics At Your Fingertips



Learn what happened the last time a particular judge, opposing counsel or company faced cases similar to yours.

Advanced out-of-the-box PTAB and TTAB analytics are always at your fingertips.

API

Docket Alarm offers a powerful API (application programming interface) to developers that want to integrate case filings into their apps.

LAW FIRMS

Build custom dashboards for your attorneys and clients with live data direct from the court.

Automate many repetitive legal tasks like conflict checks, document management, and marketing.

FINANCIAL INSTITUTIONS

Litigation and bankruptcy checks for companies and debtors.

E-DISCOVERY AND LEGAL VENDORS

Sync your system to PACER to automate legal marketing.