

Aug. 9, 1960

S. J. RUPERT

2,948,287

QUICKLY-ERECTABLE FOLDING PORTABLE SHELTER

Filed Sept. 30, 1957

2 Sheets-Sheet 1

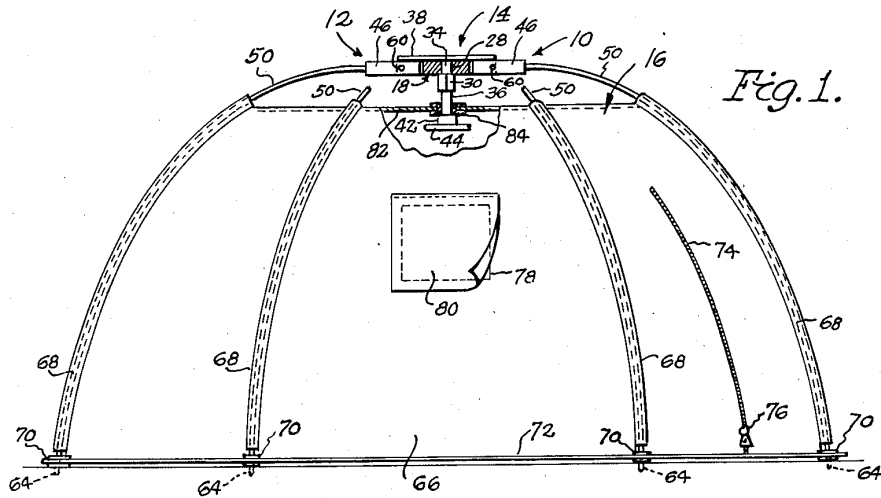

Fig. 1.

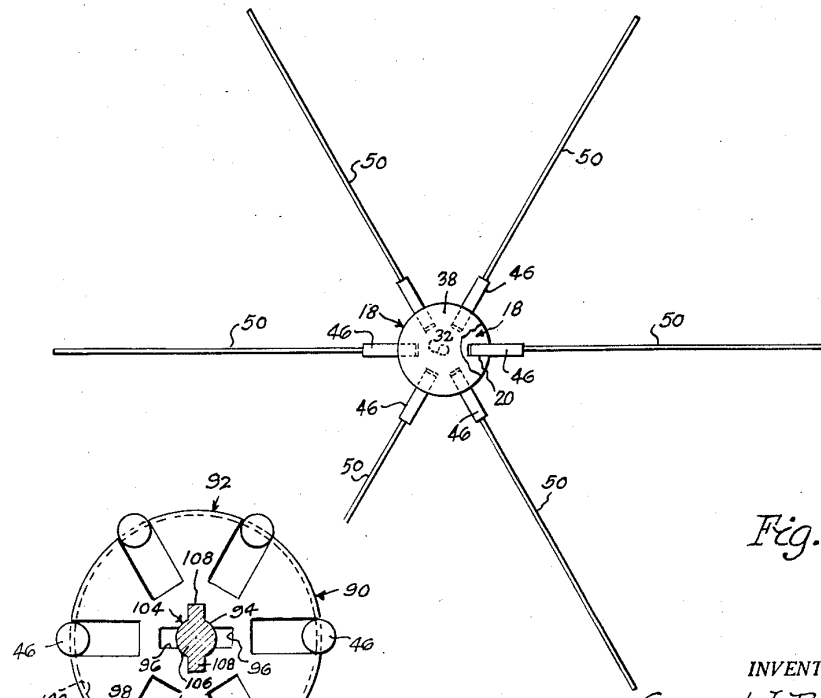

Fig. 2.

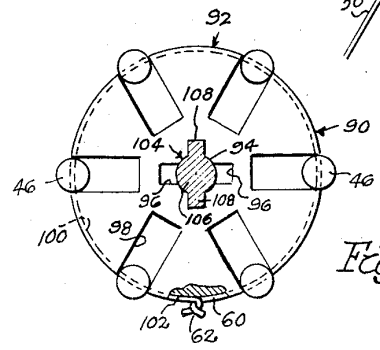

Fig. 9.

INVENTOR.
 Samuel J. Rupert
 BY Barthel + Bugbee
 Attys

Aug. 9, 1960

S. J. RUPERT

2,948,287

QUICKLY-ERECTABLE FOLDING PORTABLE SHELTER

Filed Sept. 30, 1957

2 Sheets-Sheet 2

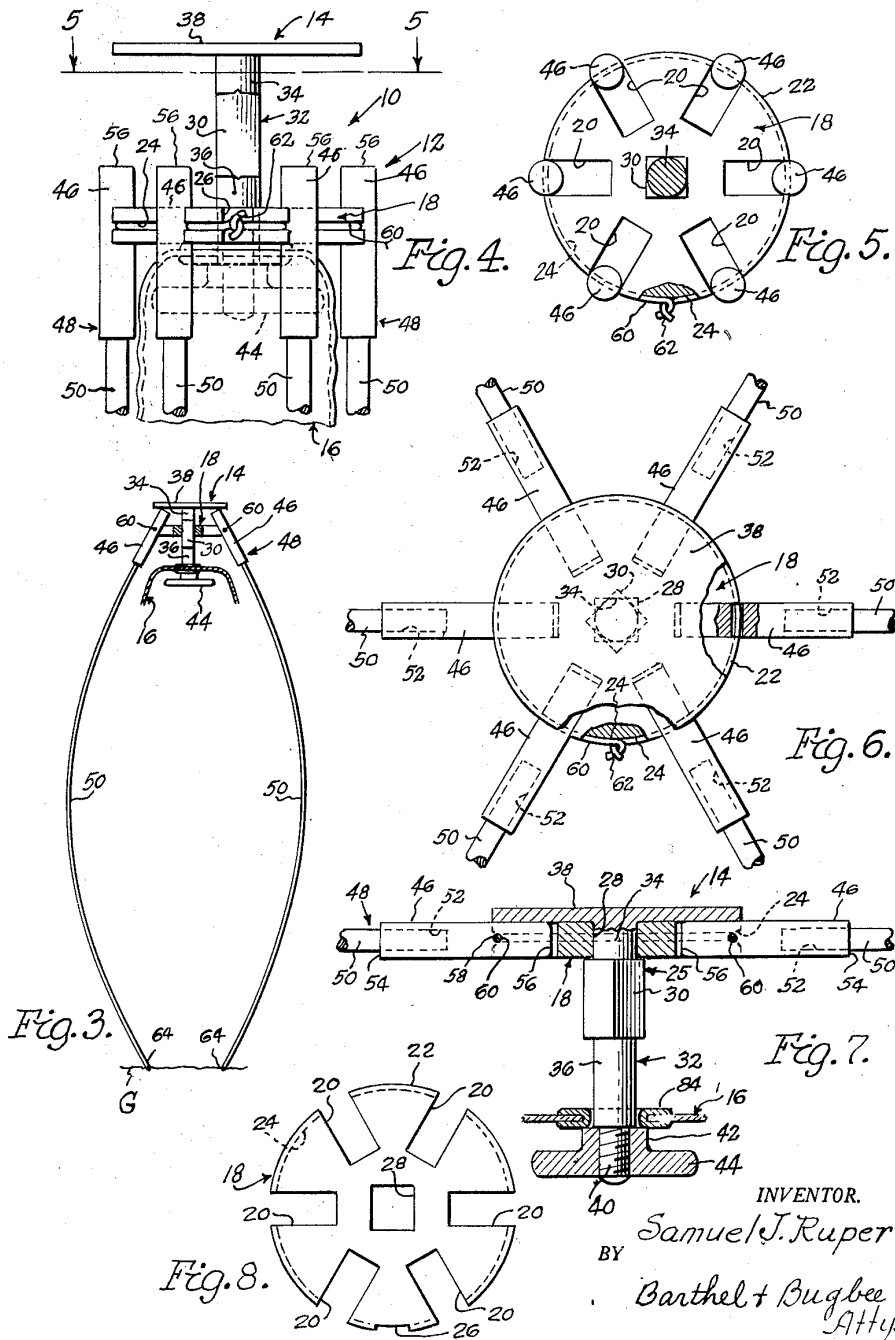

INVENTOR.
Samuel J. Rupert
BY
Barthel + Bugbee
ATTYS

1

2,948,287

QUICKLY-ERECTABLE FOLDING PORTABLE SHELTER

Samuel J. Rupert, Ann Arbor, Mich., assignor, by mesne assignments, to Charles W. Moss and Henry Stribley, both of Ann Arbor, Mich.

Filed Sept. 30, 1957, Ser. No. 687,064

15 Claims. (Cl. 135—4)

This invention relates to folding portable shelters and, in particular, to quickly-erected or quick action folding portable tent-supporting structures.

One object of this invention is to provide a quick-action folding portable tent-supporting structure having ribs of flexible material, the upper ends of which are pivoted to a quick-action locking device by means of which the operator can bow the ribs into approximately spherical form while their ends are pressed close to one another and firmly against the ground, so as to bring the upper ends of the ribs into approximately the same horizontal plane and lock them in that position by a simple and quick twist of the wrist or turn of the hand.

Another object is to provide a quick-action folding portable tent-supporting structure of the foregoing character for use with a flexible cover of approximately hemispherical shape which is distended by a snap action into this shape when the operator pulls upward on the locking device to release the lower ends of the flexible ribs from restraining engagement with the ground and thereby free them to spring outward to distend the cover.

Another object is to provide a quick-action folding portable tent-supporting structure of the foregoing character wherein the locking device includes a rib support comprising a sectored disc to which the upper ends of the ribs are pivoted, this disc having a central bore of non-circular cross-section which fits a correspondingly non-circular portion of a vertical rod for sliding motion relatively thereto while restrained from relative rotation thereto, the rod having an additional portion of circular cross-section permitting such relative rotation at that location, the rod at its upper end being provided with an abutment disc for engagement by the hand of the operator in pushing the device downward to bow the ribs outward.

Another object is to provide a quick-action folding portable tent-supporting structure, as set forth in the object immediately preceding, wherein the rod is also provided with an additional portion of circular cross-section below the portion of non-circular cross-section so as to permit relative rotation between the rod and rib support or sectored disc of the locking device both above and below the rod portion of non-circular cross-section.

Other objects and advantages of the invention will become apparent during the course of the following description of the accompanying drawings, wherein:

Figure 1 is a side elevation, partly in central vertical section, of a quick-action folding portable shelter provided with a quick-action flexible tent-supporting structure, according to one form of the invention, with the portions exaggerated by shortening the ribs in order to bring out the construction of the locking device more clearly, the latter being in its locked position with the shelter in its erected position;

Figure 2 is a top plan view of the framework and locking device for the folding portable shelter of Figure 1, with the end portion of one of the ribs omitted to con-

2

serve space, and with the cover removed in order to show the construction more clearly;

Figure 3 is a side elevation, partly in vertical section, of the framework or flexible tent-supporting structure of the portable shelter shown in Figures 1 and 2, with the ribs partly bowed during the erection of the shelter, the cover being omitted except for its upper central portion where it is secured to the locking device;

Figure 4 is a side elevation of the upper portion of the quick-action folding portable shelter of Figures 1 and 2 in its folded position;

Figure 5 is a horizontal cross-section taken along the line 5—5 in Figure 4;

Figure 6 is a top plan view of the construction shown in Figure 4, but with the ribs completely bowed and their upper ends locked in a common plane by the locking device;

Figure 7 is a side elevation partly in section of the construction shown in Figure 6, with the locking device in its locked position;

Figure 8 is a top plan view of the sectored disc of the locking device to which the ribs are pivoted; and

Figure 9 is a horizontal cross-section, similar to that of Figure 5, but showing a modification of the invention.

Referring to the drawings in detail, Figures 1 to 3 inclusive show a quick-action folding portable shelter, generally designated 10, as consisting of a foldable frame structure, generally designated 12, according to one form of the invention, including a rib supporting and locking device or head, generally designated 14, and a foldable flexible cover, generally designated 16, of fabric or other suitable material and of approximately hemispherical shape. In the illustration of the shelter 10, as shown in Figure 1, the top portion of the flexible cover 16 has been shown at a lower position than it normally occupies, in order to show the construction more clearly, and the locking head 14 has been shown on an exaggerated scale relatively to the remainder of the frame structure 12 in order to disclose its details more clearly.

The rib supporting locking device or head 14 of the frame structure 12 includes a rib support 18 in the form of a sectored pivot disc (Figures 4, 5 and 8) having radial slots 20 disposed at circumferentially-spaced intervals around the periphery 22, which is provided with an interrupted circumferential groove 24 (Figure 4), with an arcuate notch 26 therein. The disc 18 cooperates with an operating and locking plunger, generally designated 25, and is provided with a central bore 28 of non-circular cross-section adapted to fit the correspondingly non-circular portion 30 of a rod 32 having upper and lower portions 34 and 36 respectively of circular cross-section (Figures 5 and 7) above and below the portion 30 of non-circular cross-section. In this manner, the sectored disc 18 is capable of rotation relatively to the rod 32 while it is on the circular cross-section portions 34 and 36 but incapable of such relative rotation when it is on the non-circular cross-section portion 30. The rod 32 has a handle or abutment disc 38 mounted on its upper end and shown as integral therewith. In actual practice, the abutment disc 38 is preferably made separate from the rod 32 and bore to receive the upper end thereof, and welded thereto. The lower end of the rod 32 has a reduced diameter threaded portion 40 upon which is threaded the hub 42 of a hand wheel 44.

Pivotally mounted in the radial slots 20 are rib holders 46 forming the upper end portions of rib units, generally designated 48, the lower end portions comprising ribs 50 of resilient material, such as fibrous glass, the upper ends of the ribs 50 being tightly sealed in sockets 52 in the outer ends 54 of rib holders 46. The rib holders 46 near but spaced apart from their inner ends 56 (Figure 7) are bored transversely as at 58 to receive a circum-

ferential pivot wire 60 seated in the interrupted circumferential groove 24 and having its opposite ends clinched as at 62 to lock it in position (Figure 6). The lower ends 64 of the ribs 50 are preferably pointed or provided with frictional rubber tips or the like to cause them to resist sliding along the ground G (Figure 3). In order to simplify the disclosure, the ribs 50 are shown as forced in single lengths. In the shelter actually constructed, the ribs 50 have been made in jointed sections with connecting ferrules for compactness of folding, such as is shown in the co-pending application of Moss and Stribley, Serial No. 522,962, filed July 19, 1955, for Folding Portable Shelter.

The cover 16 is of generally hemispherical shape and is made of any suitable material, such as of nylon impregnated with vinyl resin. The cover 16 is made up of sectorial gussets 66 sewed or otherwise secured together at their opposite edges together with elongated rib tunnels or tubular open-ended pockets 68 for receiving the ribs 50. The lower end portions of the ribs 50, after passing through the rib tunnels 68, pass through grommets 70 in a tent floor 72 of flexible material such as fabric and preferable sewed or otherwise secured to the lower ends of the gussets 66. A door opening 74 closed by a slide fastener 76 and a window opening 78 closed by a closure flap 80 are preferably provided for the convenience of the occupants of the shelter 10. The cover 16 is provided with a top portion 82 sewed or otherwise secured to the upper ends of the gussets 66 and preferably of the same flexible material. The top portion 82 is provided at its center with a grommet 84 large enough to accommodate the lower portion 36 of circular cross-section of the shaft 32, to be held in place by the hub 42 of the hand wheel 44.

The modified rib supporting and locking device or head, generally designated 90, shown in Figure 9, has a rib support or sectored disc 92 similar in all respects to the rib support or sector disc 18 shown in Figures 5 and 8, except that its central bore 94 is of substantially circular cross-section and has grooves or notches 96 extending laterally therefrom and communicating therewith. The remainder of the rib support 92 as regards its radial slots 98, interrupted peripheral groove 100 and gap or notch 102 is similar to the corresponding parts 20 to 26 inclusive of the rib support 18 of Figures 1 to 8 inclusive.

The operating and locking plunger, generally designated 104, is also generally similar to the operating and locking plunger of Figures 1 to 8 inclusive, except that in place of the locking portion 30 of polygonal cross-section, the plunger 104 has a rod 106 of substantially circular cross-section throughout its length, but for a portion of its length corresponding to the length of the polygonal portion 30 of Figure 7, has ridges 108 projecting laterally from the rod 106 and extending axially therealong, the ridges 108 being configured to fit the grooves or notches 96.

In the operation of the invention, let it be assumed that the shelter 10 is in its unfolded position shown in part in Figure 4, with the locking device 14 in its unlocked position and with the rib units 48 consisting of the rib holders 46 and ribs 50 hanging from the rib support 18 parallel to one another in vertical positions, with the cover 16 hanging from the hand wheel 44 and shaft portion 36 in the space in the center of the frame structure 12. With the parts in this position, and with the lower ends 64 of the ribs 50 in engagement with the ground G (Figure 3), to erect the shelter 10, the user places his hand on the top of the abutment disc 38 of the locking device 14 and pushes downward upon it, at the same time rotating the disc 38 and shaft 32 a part turn to bring the non-circular shaft portion 30 into alignment with the bore 28 of the rib-supporting sectored disc 18 so as to permit the latter to slide upward therealong. Continued downward pressure upon the abutment disc 38 (Figure 3) causes it to engage and push downward upon the upper ends 56 of the rib holders 46, thereby bowing the ribs 50 outward away

from one another into approximately spherical arrangement while moving the rib holders 46 inward into horizontal positions (Figure 7), substantially perpendicular to the rod 32 so as to lie in approximately a common plane, namely the plane of the sectored disc or rib support 18. By the time this has occurred, the upper circular cross-section portion 34 of the rod 32 has passed downward into the bore 28 of the sectored pivot disc or rib support 18, whereupon the user, while still pressing downward on the abutment disc 38, rotates it a part turn to move the non-circular rod portion 30 out of alignment with the non-circular bore 28 and thus lock the latter beneath the former, as shown in dotted lines in the center of Figure 6. The user now pulls upward on the abutment disc 38, disengaging the lower ends 64 of the resilient ribs 50 from the ground G, whereupon their resilience causes them to spring outward to distend the cover 16 into a taut condition approximately in a hemispherical shape, assuming the erected position shown in Figure 1.

To "strike" or collapse the shelter 10, the reverse procedure is followed. The user presses down slightly upon the disc 38 to relieve the pressure of the rib holder ends 56 thereagainst, at the same time rotating the disc 38 a part turn until he feels the non-circular portion 30 coming into alignment with the non-circular bore 28 in the rib support 18, whereupon he relaxes his force upon the disc 38 and permits the rib assemblies 40 to push it upward, together with the rod 32, as shown in Figure 3, until the rib assemblies 48 again lie in vertical positions substantially parallel to the central rod 32 of the locking device 14. While this is occurring, the flexible cover 16 adapts itself to the space inside the rib arrangement forming the framework 12, and the shelter is ready for storage or transportation. In the shelters 10 made with jointed ribs for convenience and compactness, the ribs 50 are further separated into their respective sections for more compact packing if the user so desires. Actual tests, repeated many times, show that, starting from the extended and folded position of Figure 4, the entire shelter 10 can be erected in the position shown in Figure 1 in as short a time period as only three seconds, because of the extremely rapid operation of the locking device 14 and the snap action of the resilient ribs 50 cooperating with the flexible fabric cover 16.

The operation of the modified rib supporting and locking device or head 90 is substantially the same as that described above for the rib supporting and locking head 14 with the exception of the fact that instead of the polygonal portion 30 being rotated until it comes into alignment with the polygonal bore 28, the rod 106 is rotated by an abutment disc (not shown) similar to the abutment disc 38 to bring the ridges 108 into alignment and sliding locking engagement with the grooves or notches 96 of corresponding configuration. In other respects, the action is substantially the same as that described above, hence no duplication of description is believed necessary.

What I claim is:

1. A quickly-erectable folding portable tent-supporting structure for use with an approximately hemispherical cover of flexible sheet material, said structure comprising a rib support having a multiplicity of rib pivots mounted thereon at peripherally-spaced locations therearound and also having a central bore and a rotation-preventing locking recess extending laterally from said bore, a multiplicity of elongated ribs of resilient material adapted to be connected to the cover and having their upper end portions pivotally mounted on said pivots at said peripherally-spaced locations around said rib support, and a movable rib-flexing locking unit including an elongated rod reciprocably and rotatably mounted in said bore and having a rotation-preventing locking projection extending longitudinally along a part only of the length of said rod and projecting laterally therefrom into said recess in rotation-preventing engagement therewith, said

5

rib-flexing locking unit also including a rib-flexing abutment disposed on said rod above said projection and movable unitarily therewith into engagement with said upper end portions of said ribs; said ribs being adapted to flex arcuately and resiliently into distending engagement with the cover in response to the urging of said upper end portions of said ribs by said abutment into positions substantially perpendicular to said rod.

2. A quickly-erectable folding portable tent-supporting structure, according to claim 1, wherein said rod has a portion of substantially circular cross-section disposed in proximity to the portion thereof with the locking projection.

3. A quickly-erectable folding portable tent-supporting structure, according to claim 2, wherein the rod portion with the locking projection and the rib support bore are of approximately polygonal cross-section.

4. A quickly-erectable folding portable tent-supporting structure, according to claim 1, wherein said rod has portions of substantially circular cross-section disposed above and below the portion thereof with the locking projection.

5. A quickly-erectable folding portable tent-supporting structure, according to claim 4, wherein the rod portion with the locking projection and the rib support bore are of approximately polygonal cross-section.

6. A quickly-erectable folding portable tent-supporting structure, according to claim 1, wherein the rod portion with the locking projection and the rib support bore are of approximately polygonal cross-section.

7. A quickly-erectable folding portable tent-supporting structure, according to claim 1, wherein the rod is of substantially circular cross-section and wherein the locking projection extends laterally therefrom.

8. A quickly-erectable folding portable tent-supporting structure, according to claim 7, wherein the rib support bore is of substantially circular cross-section and wherein the recess is a groove offset radially from the bore.

9. A quick-acting rib-flexing locking device for a folding portable tent supporting structure having ribs with pivoted upper end portions, said device comprising an approximately plate-shaped rib support having a multiplicity of rib pivots mounted thereon at peripherally-spaced locations therearound and also having a central bore of generally circular cross-section and a rotation-preventing locking recess extending laterally from said bore, and a movable rib-flexing locking unit including an elongated rod of generally circular cross-section reciprocally and rotatably mounted in said bore and having a rotation-preventing locking projection extending longitudinally along a part only of the length of said rod and projecting laterally therefrom into said recess in rotation-

6

preventing engagement therewith, said rib-flexing locking unit also including a rib-flexing abutment disposed on said rod above said projection and adapted to move unitarily therewith into engagement with the pivoted upper end portions of the ribs and swing the same into positions substantially perpendicular to said rod.

10. A quick-acting locking device for a folding portable tent-supporting structure, according to claim 9, wherein said rod has a portion of substantially circular cross-section disposed in proximity to the portion thereof with the locking projection.

11. A quick-acting locking device for a folding portable tent-supporting structure, according to claim 10, wherein the rod portion with the locking projection and the rib support bore are of approximately polygonal cross-section.

12. A quick-acting locking device for a folding portable tent-supporting structure, according to claim 9, wherein said rod has portions of substantially circular cross-section disposed above and below the portion thereof with the locking projection.

13. A quick-acting locking device for a folding portable tent-supporting structure, according to claim 12, wherein the rod portion with the locking projection and the rib support bore are of approximately polygonal cross-section.

14. A quick-acting locking device for a folding portable tent-supporting structure, according to claim 9, wherein the rod portion with the locking projection and the rib support bore are of approximately polygonal cross-section.

15. A quick-acting locking device for a folding portable tent-supporting structure, according to claim 9, wherein the rod is of substantially circular cross-section and wherein the locking projection extends laterally therefrom.

References Cited in the file of this patent

UNITED STATES PATENTS

14,655	Hartwell	Apr. 15, 1856
639,419	Manuel	Dec. 19, 1899
1,414,616	Beehler	May 2, 1922
1,588,391	Berry	June 8, 1926
1,589,063	Fondo	June 15, 1926
2,306,706	Lucas	Dec. 29, 1942

FOREIGN PATENTS

859,919	France	Sept. 20, 1940
---------	--------	----------------

OTHER REFERENCES

Publication: "Lincoln-Mercury Times," dated May-June, 1955, item 11, on page 27.