

Bin Size and Linear $v(z)$

Christopher L. Liner*, University of Tulsa; Ralph Gobeli, Mercury International Technology

Summary

The choice of bin size is an important issue in 3-D seismic survey design. It effects acquisition cost, as well as quality of processing and interpretation. The standard formula for calculating bin size is based, ultimately, on constant velocity assumptions. Here we demonstrate that a useful formulation of the problem can be developed based on a linear $v(z)$ velocity model. The bin size calculated by the $v(x)$ method can differ by 40% or more from the constant velocity estimate.

Introduction

Bin size for a 3-D seismic survey is designed to eliminate, or minimize, spatial aliasing of the recorded wavefield. Data aliasing is detrimental to many seismic processing steps, and ultimately degrades the final image quality. But while data quality argues for a small bin, economics drive the system toward larger bins which lower acquisition and processing costs. For a given acquisition area, the costs increase dramatically with decreasing bin size. Clearly, bin size determination is an important technical and economic issue.

In this paper we present a method for estimating bin size based on a linear $v(z)$ velocity model. This represents a move toward reality from the standard practice of constant velocity calculations (Yilmaz, 1987). To be fair, we expect that many major companies and operators are currently using some form of $v(z)$ for bin calculations. However, the only mention of this practice we find in the literature is Bee *et al.* (1994), where linear $v(z)$ seems to be applied to migration distance estimates not bin size calculations.

Spatial Aliasing Review

Spatial aliasing occurs when wavelet time delay between adjacent traces is greater than half the wavelet period (Yilmaz, 1987). This is termed “data aliasing” to distinguish it from “process aliasing” which can (but should not) be produced by migration, dip-moveout (DMO), radon transforms, and other seismic processing steps. For a band-limited wavelet, data aliasing has the effect of aligning sidelobes along a slope antithetic to the true slope. Performance of multichannel programs like migration and DMO are degraded by these false slopes. There has been work done on “de-aliasing” 3-D seismic data, but the preferred path is to record unaliased data in the field.

The conventional condition for avoidance of data aliasing for a reflected arrival is

$$BinSize \leq Period/Slope , \tag{1}$$

where the wavelet period is given by

$$Period = 1/f_{dom} , \tag{2}$$

and f_{dom} is the dominant frequency. The slope used in this calculation is the constant velocity, zero offset slope (Yilmaz, 1987) given by

$$Slope = \frac{dt_0}{dy} = \frac{v}{2 \sin\theta} , \tag{3}$$

where y is the midpoint coordinate, v is velocity, and θ is the geological dip. With these definitions, the bin estimate becomes

$$BinSize \leq \frac{v}{2 f_{dom} \sin\theta} \tag{4}$$

The safest bin estimate is based on $\theta = 90^\circ$. This allows for fault diffraction limbs which have a slope equivalent to a 90° dipping bed.

Construction For Linear $v(z)$

The theory of seismic raypaths in linear $v(z)$ media is well-known (Slotnick, 1959; Telford et al., 1976). Figure 1 shows the geometry for our problem. The source and receiver are coincident on the earth surface, and velocity in the earth increases linearly with depth, $v(z) = v_0 + kz$, where k is the velocity gradient in $[ft/sec]/ft$. The constant velocity raypath is straight and its reflection time is t_0 , while the $v(z)$ ray is a circular arc with reflection time t_v . Both the source point and the curved ray reflection point are along radii from the center of a circle above the acquisition surface (Slot nick, 1959).

From the geometry, we derive a relationship for the reflection time $t_v(y)$. The event slope can then be derived from dt_v/dy , and the bin size, bin_v , is found by applying Equation (1). The result is

$$y = z/Tan\theta \tag{5}$$

$$x = y + \frac{v_0}{k Tan\theta} \tag{6}$$

$$p = (v_0^2 + k^2 x^2)^{-0.5} \tag{7}$$

$$\alpha_0 = \sin^{-1}(p v_0) \tag{8}$$

$$t_v = \frac{2}{k} \frac{Tan(\theta/2)}{Tan(\alpha_0/2)} \tag{9}$$

Downloaded 04/18/14 to 173.226.64.254. Redistribution subject to SEG license or copyright; see Terms of Use at http://library.seg.org/

Bin Size and Linear $v(z)$

$$\frac{dt_v}{dy} = \frac{v_0}{(v_0^2 + k^2 x^2) \text{Sin}(w) \text{Cos}(w)} \quad (10)$$

$$w = 0.5 \text{Sin}^{-1} \left[\frac{v_0}{(v_0^2 + k^2 x^2)^{.5}} \right] \quad (11)$$

$$bin_v = [f_{dom} (dt_v/dy)]^{-1} \quad (12)$$

In these formulae, p is the ray parameter, α_0 is the take-off angle, and w is a temporary variable to simplify the slope expression.

Examples

Consider a Gulf Coast 3-D survey being planned over a target horizon at a depth of 5000 feet. We use the standard velocity function of $v(z) = 6000 + 0.6 z$ ft/sec (Slotnick, 1959). For the constant velocity calculation we use the average velocity of 7500 ft/sec. The dominant frequency is set to 40 Hz. The bin size calculation is done for $\theta = 45$ and 85 degrees. The results are

$$\begin{aligned} \theta = 45 : \quad bin_c &= 132.6 \text{ ft} \\ &bin_v = 135.2 \text{ ft} \\ \theta = 85 : \quad bin_c &= 94.5 \text{ ft} \\ &bin_v = 75.6 \text{ ft} \end{aligned}$$

If the 85 degree bin_c estimate is used in an area where this velocity gradient is present, dips beyond about 60 - 65 degrees will be spatially aliased (see Figure ??). Repeating the same calculation for a stronger gradient, $k = .9$, yields

$$\begin{aligned} \theta = 45 : \quad bin_c &= 145.8 \text{ ft} \\ &bin_v = 151.2 \text{ ft} \\ \theta = 85 : \quad bin_c &= 103.5 \text{ ft} \\ &bin_v = 75.9 \text{ ft} . \end{aligned}$$

These examples do not suggest a simple rule such as $bin_c > bin_v$. Figure 2 shows a plot of bin size versus dip. Parameters are those of the first example above. It can be seen that the constant velocity calculation recommends too-small a bin for $\theta < 45$, and too-large a bin for $\theta > 45$. This is also seen in Figure 3, where the effect of variable velocity gradient is added. The percent difference between bin_c and bin_v is largest for

Conclusions

Linear $v(z)$ can be incorporated into bin size calculations. The $v(z)$ bin, bin_v , tends to be less than the constant velocity bin, bin_c , but this is not always the case. If bin_c is used in 3-D survey design and $bin_v > bin_c$, then steep dips will tend to be aliased. If $bin_v < bin_c$, then extra costs are incurred for a bin smaller than required. Fine tuning the bin size may allow cost savings and data quality improvements, particularly with respect to amplitude information which is easily degraded by data aliasing.

References

- Bee, M. F., Bearden, J. M., Herkenhoff, E. F., Supiyanto, H., and Koestoer, B., 1994, Efficient 3-D seismic surveys in a jungle environment, First Break, vol. 12, no.5 , p.253-259.
- Slotnick, M. M., 1959, Lessons in Seismic Computing, Society of Exploration Geophysicists, Tulsa, OK. (reprint 1989)
- Telford, W. M., Geldart, L. P., Sheriff, R. E., and Keys, D. A., 1976, Applied Geophysics, Cambridge University Press, New York, NY. (reprint 1981)
- Yilmaz, O., 1987, Seismic Data Processing, Society of Exploration Geophysicists, Tulsa, OK.

Bin Size and Linear $v(z)$

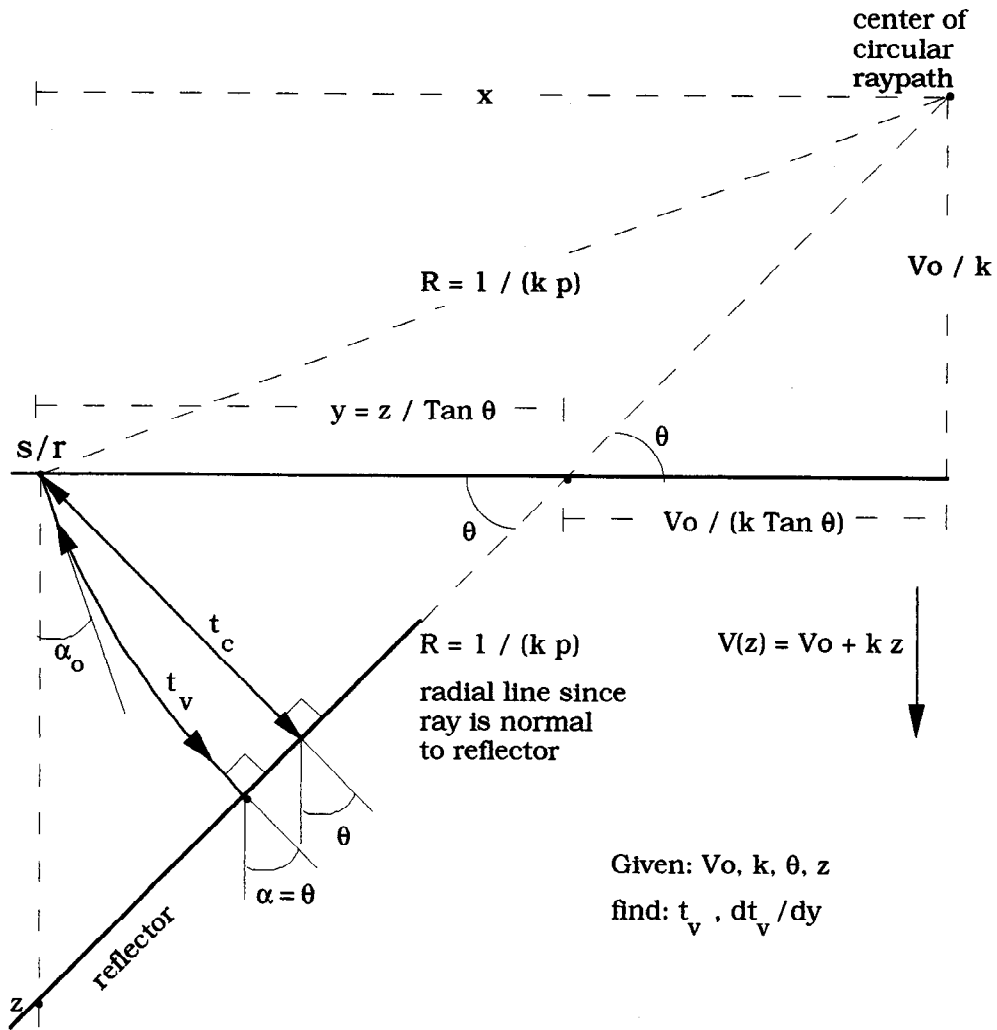

Figure 1: Geometry for the linear $v(z)$, dipping reflector problem. As is well known, the $v(z)$ ray is a circular arc. See text for details.

Bin Size and Linear $v(z)$

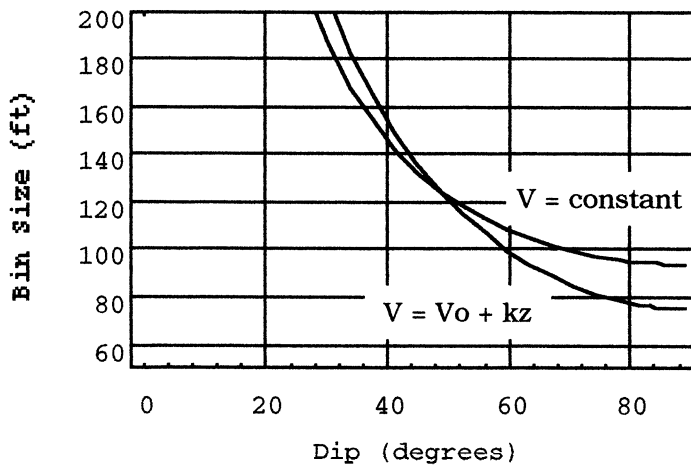

Figure 2: Comparison of bin size recommendation based on constant velocity and linear $v(z)$. Parameters for this test are given in the text. By using a constant velocity bin, we either use too small a bin ($\text{dip} < 45$) and waste money, or use too large a bin ($\text{dip} > 45$) and risk spatial aliasing.

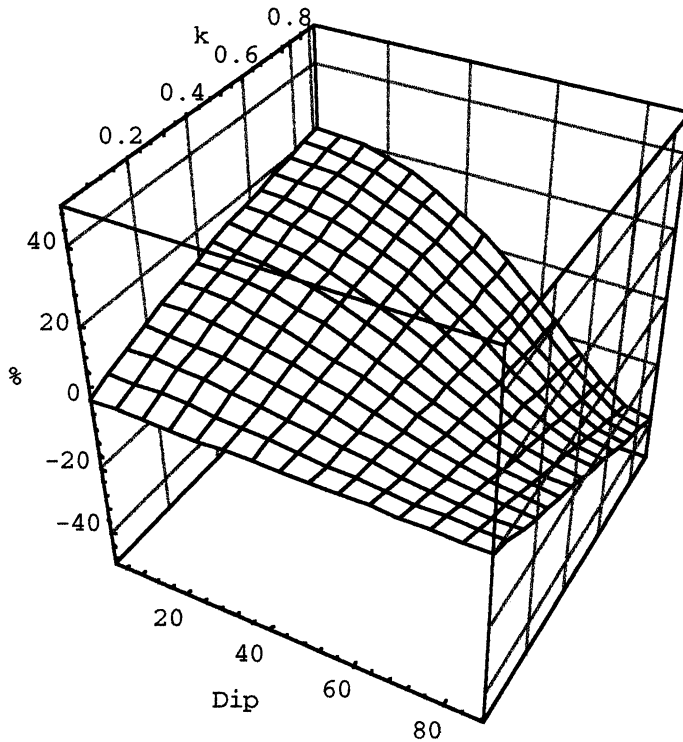

Figure 3: Percent difference between bin_c and bin_l , as a function of dip and velocity gradient, k . Negative values indicate $bin_c > bin_l$. For steep dips and strong velocity gradients, the constant velocity bin can easily be 30% too large. This could lead to significant spatial aliasing.