



US006073218A

United States Patent [19]
DeKoning et al.

[11] **Patent Number:** **6,073,218**
[45] **Date of Patent:** **Jun. 6, 2000**

[54] **METHODS AND APPARATUS FOR COORDINATING SHARED MULTIPLE RAID CONTROLLER ACCESS TO COMMON STORAGE DEVICES**

[75] Inventors: **Rodney A. DeKoning; Gerald J. Fredin**, both of Wichita, Kans.

[73] Assignee: **LSI Logic Corp.**, Milpitas, Calif.

[21] Appl. No.: **08/772,614**

[22] Filed: **Dec. 23, 1996**

[51] **Int. Cl.⁷** **G06F 13/16**

[52] **U.S. Cl.** **711/150; 711/114; 711/148; 711/149; 711/151; 711/152; 711/153; 711/162; 711/168; 710/20; 710/21; 710/38; 710/241; 714/6; 714/11**

[58] **Field of Search** **711/114, 152, 711/145, 148, 149, 150, 151, 153, 168, 162; 714/6, 11; 710/20, 21, 38, 241**

[56] **References Cited**

U.S. PATENT DOCUMENTS

3,702,006	10/1972	Page	444/1
5,101,492	3/1992	Schultz et al.	395/575
5,148,432	9/1992	Gordon et al.	371/10.1
5,210,860	5/1993	Pfeffer et al.	395/575
5,249,279	9/1993	Schmenk et al.	395/425
5,317,731	5/1994	Dias et al.	395/600
5,331,476	7/1994	Fry et al.	360/53
5,367,669	11/1994	Holland et al.	395/575
5,379,417	1/1995	Lai et al.	706/916
5,386,324	1/1995	Fry et al.	360/53
5,388,108	2/1995	DeMoss et al.	371/51.1
5,434,970	7/1995	Schiffleger	395/200
5,440,743	8/1995	Yokota et al.	395/650
5,446,855	8/1995	Dang et al.	395/401
5,455,934	10/1995	Holland et al.	395/404
5,459,864	10/1995	Brent et al.	395/650
5,495,601	2/1996	Narang et al.	395/600
5,535,365	7/1996	Barriso et al.	711/152
5,546,535	8/1996	Stallmo et al.	395/182.07

(List continued on next page.)

FOREIGN PATENT DOCUMENTS

0493984	7/1992	European Pat. Off.	G06F 11/10
0551718	7/1993	European Pat. Off.	G06F 11/20
0707269	4/1996	European Pat. Off.	G06F 12/08
0645702	3/1995	Germany	.
9513583	5/1995	WIPO	G06F 12/00

OTHER PUBLICATIONS

A. Case for Redundant Arrays of Inexpensive Disks (RAID); David Patterson, Garth Gibson & Randy kata; Dec., 1987; pp. 1-24.

Primary Examiner—Hiep T Nguyen

[57] **ABSTRACT**

Methods and associated apparatus for performing concurrent I/O operations on a common shared subset of disk drives (LUNs) by a plurality of RAID controllers. The methods of the present invention are operable in all of a plurality of RAID controllers to coordinate concurrent access to a shared set of disk drives. In addition to providing redundancy features, the plurality of RAID controllers operable in accordance with the methods of the present invention enhance the performance of a RAID subsystem by better utilizing available processing power among the plurality of RAID controllers. Under the methods of the present invention, each of a plurality of RAID controllers may actively process different I/O requests on a common shared subset of disk drives. One of the plurality of controllers is designated as primary with respect to a particular shared subset of disk drives. The plurality of RAID controllers then exchange messages over a communication medium to coordinate concurrent access to the shared subset of disk drives through the primary controller. The messages exchanged include semaphore lock and release requests to coordinate exclusive access during critical operations as well as cache and meta-cache data to maintain cache coherency between the plurality of the RAID controllers with respect to the common shared subset of disk drives. These messages are exchanged via any of several well known communication mediums including, a shared memory common to the plurality of controllers and the communication bus connecting the shared subset of disk drives to each of the plurality of controllers.

36 Claims, 11 Drawing Sheets

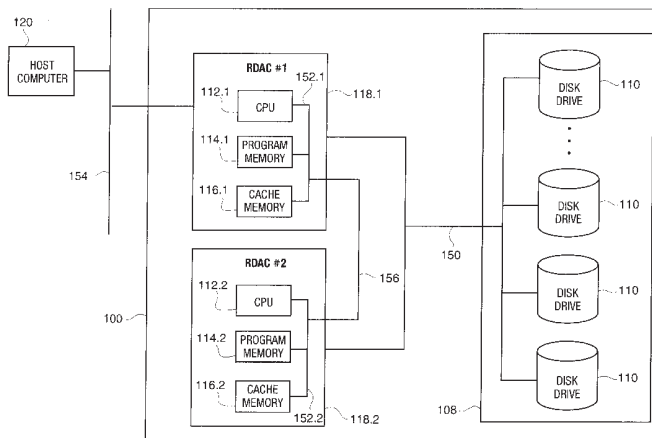

U.S. PATENT DOCUMENTS

5,548,711	8/1996	Brant et al.	395/182.03	5,694,571	12/1997	Fuller	395/440
5,603,062	2/1997	Sato et al.	710/52	5,715,447	2/1998	Hayashi et al.	395/608
5,666,511	9/1997	Suganuma et al.	711/114	5,761,705	6/1998	DeKoning et al.	711/113
5,678,026	10/1997	Vertti et al.	711/152	5,764,922	6/1998	Peacock et al.	395/275
5,682,537	10/1997	Davies et al.	395/726	5,787,304	7/1997	Hodges et al.	395/821
				5,845,292	12/1998	Bohannon et al.	707/202

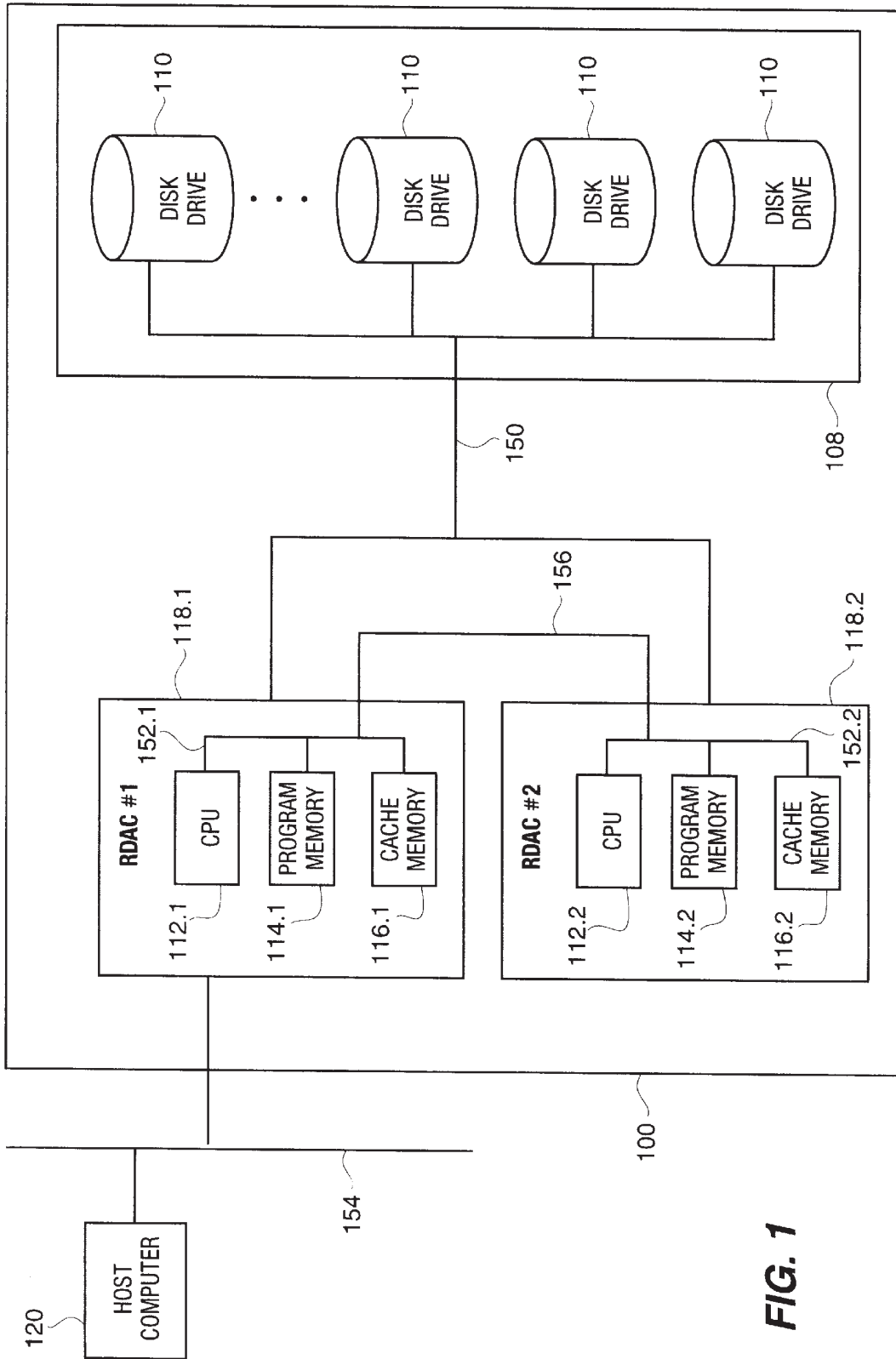

FIG. 1

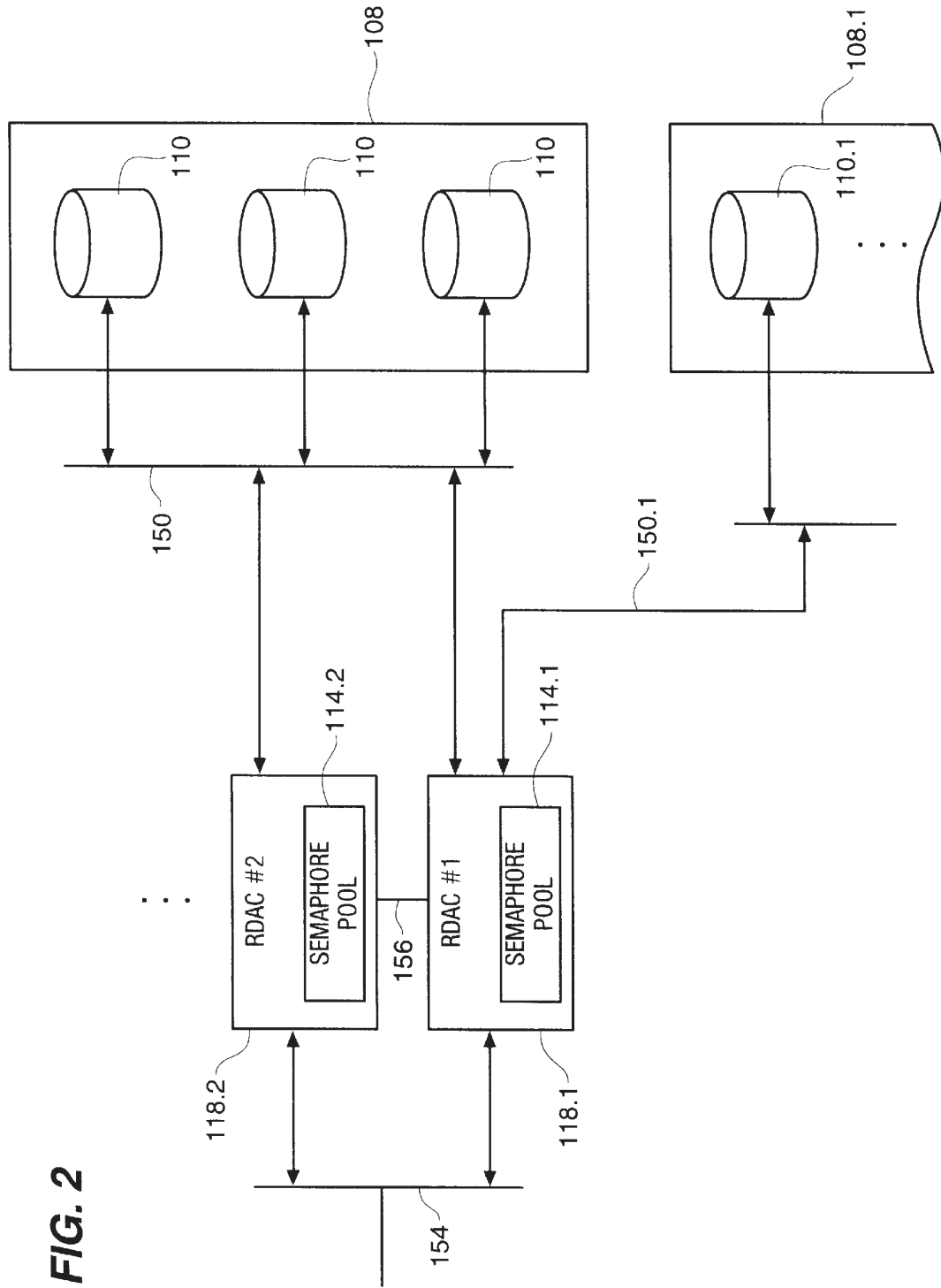

FIG. 2

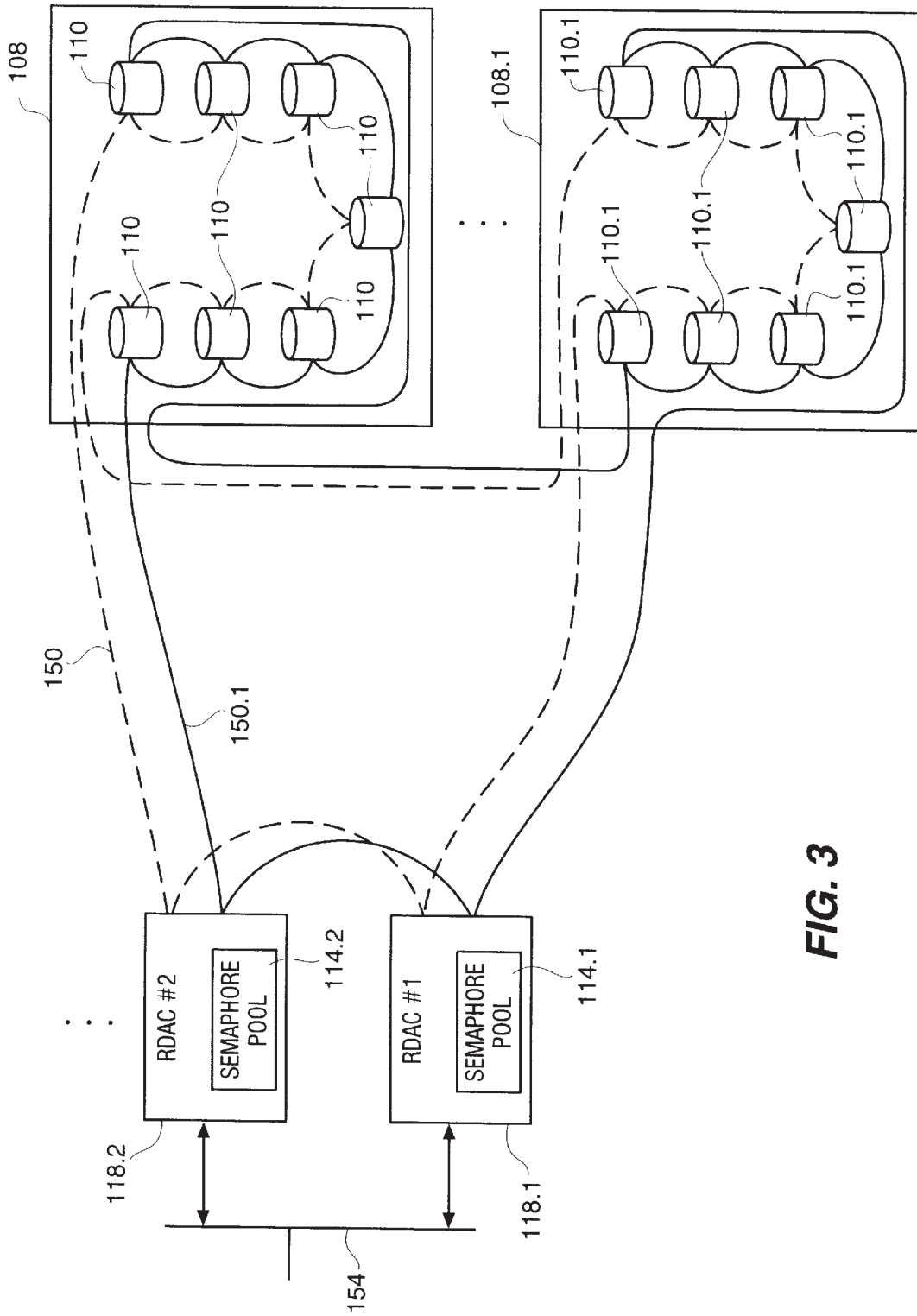

FIG. 3

Explore Litigation Insights

Docket Alarm provides insights to develop a more informed litigation strategy and the peace of mind of knowing you're on top of things.

Real-Time Litigation Alerts



Keep your litigation team up-to-date with **real-time alerts** and advanced team management tools built for the enterprise, all while greatly reducing PACER spend.

Our comprehensive service means we can handle Federal, State, and Administrative courts across the country.

Advanced Docket Research



With over 230 million records, Docket Alarm's cloud-native docket research platform finds what other services can't. Coverage includes Federal, State, plus PTAB, TTAB, ITC and NLRB decisions, all in one place.

Identify arguments that have been successful in the past with full text, pinpoint searching. Link to case law cited within any court document via Fastcase.

Analytics At Your Fingertips



Learn what happened the last time a particular judge, opposing counsel or company faced cases similar to yours.

Advanced out-of-the-box PTAB and TTAB analytics are always at your fingertips.

API

Docket Alarm offers a powerful API (application programming interface) to developers that want to integrate case filings into their apps.

LAW FIRMS

Build custom dashboards for your attorneys and clients with live data direct from the court.

Automate many repetitive legal tasks like conflict checks, document management, and marketing.

FINANCIAL INSTITUTIONS

Litigation and bankruptcy checks for companies and debtors.

E-DISCOVERY AND LEGAL VENDORS

Sync your system to PACER to automate legal marketing.