

Patent Publication (A)

Patent Application Publication No.: H06-176114

Publication Date: June 24, 1994

Application No.: H04-324268	Applicant: CANON INC.
Application Filing Date: December 3, 1992	Inventor(s): Yoichi YAMAGISHI

Title IMAGE PROCESSING SYSTEM AND INFORMATION PROCESSOR

Abstract:

An image processing system which enables to detach an image pickup apparatus having an image pickup means to a CPU having a keyboard, a display, a control unit and an image pickup apparatus detachable detecting means. Further the image processing system comprising the control unit sets up a display content of the display in response to the detecting output by the image pickup apparatus detachable detecting means and enables to detach the image pickup apparatus having the image pickup means from the information processing system having the outer case position detecting means.

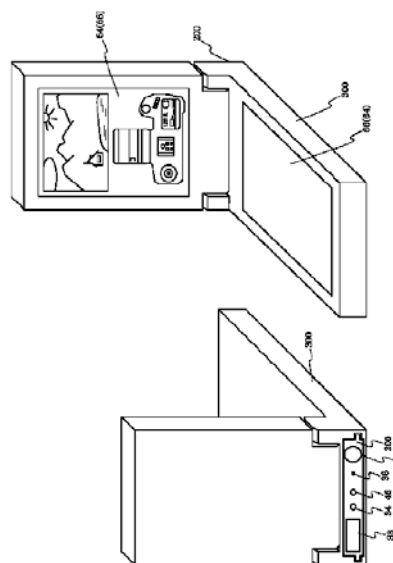

1 [CLAIMS]
2

3 1. An information processing system comprising:
4

5 an information processing apparatus having operation means, display means, control means, connection
6 detecting means for detecting that an image pickup apparatus is connected; and
7

8 wherein the image pickup apparatus is removable, and the control means control display image setting of the
9 display means based on output of the connection detecting means.
10

11
12
13 2. An information processing system according to claim 1, wherein the control means prohibit displaying images
14 from the image pickup apparatus when the connection detecting means detect that the image pickup apparatus is not
15 connected.
16

17
18
19 3. An information processing system comprising:
20

21 an information processing apparatus having operation means, display means, control means;
22

23 an image pickup apparatus having image pickup means and program storage means; and
24

25 wherein the control means allow the image pickup means being
26

27 active when the image pickup apparatus is connected.
28
29
30

31 4. An information processing system according to claim 1, wherein the display means display output images of
32 the image pickup means when the image pickup means are active; and display means display output images of
33 memory means when the image pickup means are not active.
34
35
36

37 5. An information processing system according to claim 1, wherein the image pickup means have a functional
38 part for photographing and the functional part is exposed outside of the information processing apparatus when the
39 image pickup apparatus is connected.

1 **DESCRIPTION**

2
3
4
5 1. Field of the Invention

6
7 The present invention relates to an image processing system for photographing an image and an information
8 processing system.
9

10 2. Related Background Art

11
12 In the past, electronic still cameras capable of recording still images on a recording medium such as a memory card
13 having solid-state memory elements have been put on the market. Electronic pocketbooks and portable
14 computers, for which memory cards can be used, have also been commercialized. For inputting an image to a
15 portable computer or the like, an image photographed using an electronic still camera is recorded in a memory
16 card and then the card is inserted into the portable computer so that the image is read out.
17

18 3. Problems to be Solved by the Invention

19
20 However, in the foregoing method of recording an image photographed by an electronic still camera on a memory
21 card and inserting the card into a portable computer for image reading, many steps must be taken for photography.
22 Moreover, both the electronic still camera and portable computer must be carried about. This is very inconvenient.
23

24 An object of the present invention is to provide an image processing system and information processing system for
25 solving all or part of the aforesaid problems.
26

27 Another object of the present invention is to further improve the system regarding this embodiment that permits
28 for expanded periods of use.
29

30 [Means for Solving the Problem]

31
32 In an effort to accomplish the foregoing objects, an image processing system is disclosed as the first embodiment
33 of the present invention. The image processing system comprises an information processing apparatus including
34 operating means for entering information, processing means for processing and outputting information entered at
35 the operating means, and an interface for connecting an external apparatus, and an image pickup apparatus
36 detachable from the interface, including image pickup means for picking up an object image, and storage means
37 for storing programs one of which is run by the processing means to operate the image pickup means.
38

39 Furthermore, this invention is characterized wherein the aforesaid control means prohibit displaying images from
40 the image pickup apparatus when the connection detecting means detect that the image pickup apparatus is not
41 connected.
42

43 Furthermore, this invention is characterized by an information processing apparatus having operation means,
44 display means, control means; an image pickup apparatus having image pickup means and program storage
45 means; and wherein the control means allow the image pickup means being active when the image pickup
46 apparatus is connected.

1 Additionally, the invention is further characterized by the display means display output images of the aforesaid
2 image pickup means when the image pickup means are active; where the display means display output images of
3 memory means when the image pickup means are not active.

4
5 Furthermore, the invention is characterized by the image pickup means having a functional part for photographing
6 and the functional part is exposed outside of the information processing apparatus when the image pickup
7 apparatus is connected.

8
9 An embodiment of the present invention will be described with reference to the drawings.

10
11 In FIGS. 1A and 1B, reference numeral 200 denotes an image pickup apparatus and 300 denotes an information
12 processing apparatus.

13
14 The image pickup apparatus 200 comprises image pickup means 202, program storage means 50, an interface 52,
15 and a connector 54.

16
17 Reference numeral 50 denotes program storage means for storing programs each describing imaging for the image
18 pickup means 202. The stored programs are run by the information processing apparatus 300. 52 denotes an
19 interface for providing the interface with the information processing apparatus 300. 54 denotes a connector for
20 use in transferring a data signal or a control signal to or from the information processing apparatus 300 and
21 supplying power to the program storage means 50.

22
23 The configuration of the image pickup means 202 will be described below.

24
25 Reference numeral 10 denotes a lens array. 12 denotes a shutter having a capability of a diaphragm. 14 denotes an
26 image pickup element for converting an optical image into an electric signal. 16 denotes an A/D converter for
27 converting analog output of the image pickup element 14 into a digital signal. 18 denotes a clock circuit for
28 supplying a clock signal or a control signal to the image pickup element 14, A/D converter 16, memory control
29 circuit 20, and D/A converter 36. The clock circuit 18 is controlled by a memory control circuit 20 and an image
30 pickup control circuit 40. 22 denotes an image compression/extension circuit for compressing or extending data by
31 performing adaptive discrete cosine transformation (ADCT) or the like. 24 denotes an image memory.

32
33 Reference numeral 30 denotes a shutter drive circuit for driving the shutter 12. 32 denotes a lens drive circuit for
34 driving a focusing lens in the lens array 10. 34 denotes a distance measuring circuit for measuring a distance to an
35 object. 36 denotes a photometry circuit for metering a brightness level of an object. 38 denotes a flash. 40 denotes
36 an image pickup control circuit for controlling the whole of the image pickup means.

37
38 Reference numeral 42 denotes a power circuit. 44 denotes a battery. The power circuit 42 comprises a battery
39 detector, a DC-DC converter, and a switch for selecting a block to be energized. The power circuit 42 detects the
40 presence or absence of the battery 44, the type of the battery 44, and an amount of power remaining in the
41 battery 44, controls the DC-DC converter according to the results of detection and an instruction sent from the
42 image pickup control circuit 40, and supplies a required voltage to each component for a required time interval.

43
44 The image pickup control circuit 40 causes the lens drive circuit 32 to drive the focusing lens in the lens
45 array 10 according to the result of measurement performed by the distance measuring circuit 34 and thus controls
46 the lens array 10 so that the lens array 10 comes into focus. Based on the result of photometry performed by the

1 photometry circuit 36, the image pickup control circuit 40determines the time interval of keeping the
2 shutter 12 open using the shutter drive circuit 30 so as to provide an optimal magnitude of exposure.

3
4 The configuration of the information processing apparatus 300 will be described below.

5
6 Reference numeral 60 denotes control means for controlling the whole information processing
7 apparatus 300. 62 denotes memory means for storing programs and variables for performing the operations,
8 which will be described later, of the control means 60. 64 denotes a display means for displaying characters,
9 images, and voice required with the run of a program in the control means 62; such as, a liquid crystal display unit
10 or a loudspeaker. 66 denotes operating means for use in entering a variety of operational commands to be sent to
11 the control means 60.

12
13 Reference numeral 68 denotes a power circuit. 70 denotes a battery. The power circuit 68 comprises a battery
14 detector, a DC-DC converter, and a switch for selecting a block to be energized. The power circuit 68 detects the
15 presence or absence of the battery 70, the type of the battery 70, and an amount of power remaining in the
16 battery 70, controls the DC-DC converter according to the result of detection and the instruction sent from the
17 control means 60, and then supplies required voltages for a required time interval.

18
19 Reference numeral 72 denotes an interface for providing the interface with the image pickup
20 apparatus 200. 74 denotes a connector for use in transferring a data signal and a control signal to or from the
21 image pickup apparatus 200 and supplying power to an interface 52 and the program storage means 50.

22
23 Reference numeral 76 denotes a recording medium 90 such as a hard disk or a memory card, or an interface for
24 providing the interface with communication means 100. 78 denotes a connector for use in transferring a data
25 signal and a control signal to or from the recording medium 90 and supplying power to the recording
26 medium 90. 80 denotes a connector for use in transferring a data signal and a control signal to or from the
27 communication means 100 and supplying power to the communication means 100.

28
29 Reference numeral 82 denotes an image pickup apparatus detachment detecting means for detecting the
30 detachment of the image pickup apparatus 200 from the information processing apparatus 300 using a mechanical,
31 electrical, or optical method.

32
33 Reference numeral 90 denotes a recording medium such as a hard disk or a memory card. 92 denotes a connector
34 for use in transferring a data signal or a control signal to or from the information processing apparatus 300 and
35 receiving power. 94 denotes an interface for providing the interface with the information processing
36 apparatus 300. 96 denotes a recording area for use in recording an image signal.

37
38 Reference numeral 100 denotes a communication means for communicating with external equipment over a
39 communication line. 102 denotes a connector for use in transferring a data signal and a control signal to or from
40 the information processing apparatus 300 and receiving power. 104 denotes an interface for providing the
41 interface with the information processing apparatus 300. 106denotes a communication control circuit for
42 controlling the communication with external equipment. The communication control circuit controls
43 communication according to the protocol of a layer to be connected by running a predetermined program, and
44 converts, inversely converts, modulates, and demodulates data. 108denotes a connector for use in transferring a
45 data signal and a control signal to or from external equipment over a communication line. The use of the
46 connector 108permits transmission or other communication to or from external equipment directly or over a
47 communication line.

Explore Litigation Insights

Docket Alarm provides insights to develop a more informed litigation strategy and the peace of mind of knowing you're on top of things.

Real-Time Litigation Alerts



Keep your litigation team up-to-date with **real-time alerts** and advanced team management tools built for the enterprise, all while greatly reducing PACER spend.

Our comprehensive service means we can handle Federal, State, and Administrative courts across the country.

Advanced Docket Research



With over 230 million records, Docket Alarm's cloud-native docket research platform finds what other services can't. Coverage includes Federal, State, plus PTAB, TTAB, ITC and NLRB decisions, all in one place.

Identify arguments that have been successful in the past with full text, pinpoint searching. Link to case law cited within any court document via Fastcase.

Analytics At Your Fingertips



Learn what happened the last time a particular judge, opposing counsel or company faced cases similar to yours.

Advanced out-of-the-box PTAB and TTAB analytics are always at your fingertips.

API

Docket Alarm offers a powerful API (application programming interface) to developers that want to integrate case filings into their apps.

LAW FIRMS

Build custom dashboards for your attorneys and clients with live data direct from the court.

Automate many repetitive legal tasks like conflict checks, document management, and marketing.

FINANCIAL INSTITUTIONS

Litigation and bankruptcy checks for companies and debtors.

E-DISCOVERY AND LEGAL VENDORS

Sync your system to PACER to automate legal marketing.