

Three-View, Plan View and Elevation View Drawings

Technical drawings are the language engineers and architects use to communicate their ideas and designs to journeymen. It is a language based on lines and symbols that have specific meanings. Journeymen must possess the skill to interpret these symbols and lines, so that they may install and maintain piping systems.

This chapter discusses the use of three-view drawings, section drawings, and schematic drawings, and introduces some special-purpose drawings, such as exploded drawings and wiring diagrams.

The photograph in Fig. 2-1 clearly depicts the over-all appearance of a concrete block. A three-view drawing will most clearly show the appearance as well as the exact size and other details of construction of an object.

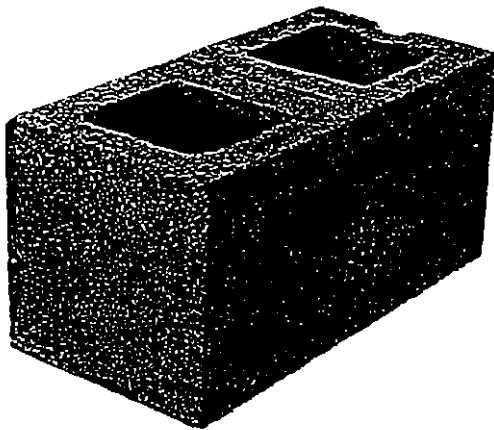

Fig. 2-1

The three-view drawing of the concrete block shown in Fig. 2-2 is a drawing with the Top View positioned directly above the Front View and the Right-Side or Left-Side View positioned directly to the right or left of the Front View.

The Front View of the concrete block in Fig. 2-2 does not show what is normally considered the Front View.

The Front View in a 3 View drawing does not necessarily show the "front" of an object.



Top View

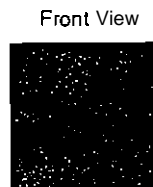

Front View

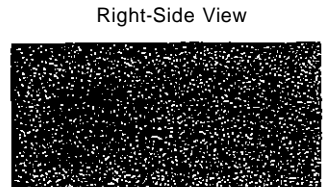

Right-Side View

Fig. 2-2

Also, the Right-Side View in Fig. 2-2 does not represent what is usually considered the "Right-Side" of the concrete block.

The key to understanding the relationship of the views in a three-view drawing is the Front View. The Front View locates the object directly in front of the viewer. See Fig. 2-3.

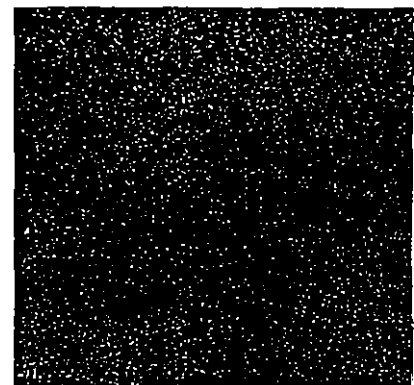

Fig. 2-3

How, then, is the Right-Side View related to the Front View?

With the Front View directly in front of the viewer, the Right-Side View is what the viewer would see if he or she were to walk to their right until the right side of the object was directly in front of them. See Fig. 24.

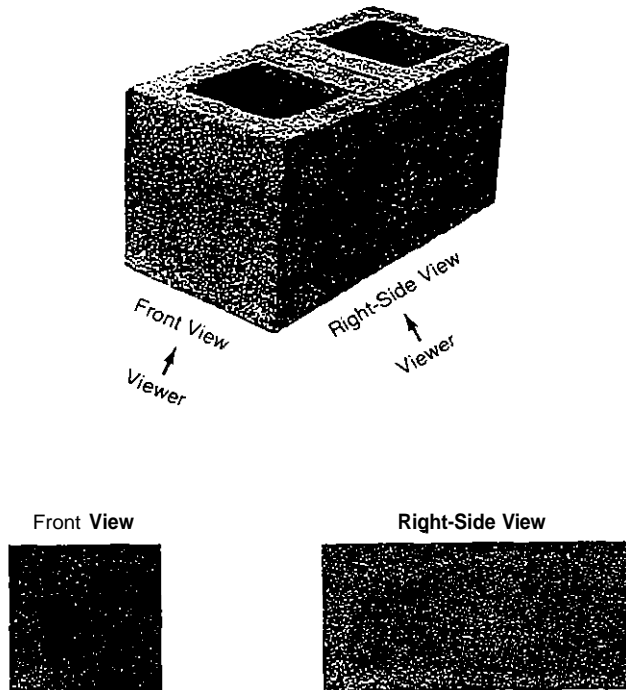

Fig. 2-4

How would the Top View be related to the Front View?

The Top View in Fig. 2-5 shows the object as the viewer would see it when they stand at the Front View, as shown in Fig. 24, and look directly down on the object.

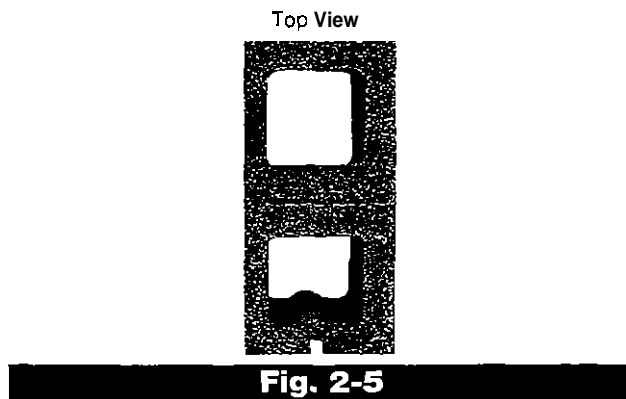

Fig. 2-5

Fig. 2-6 is a three-view drawing of a concrete block.

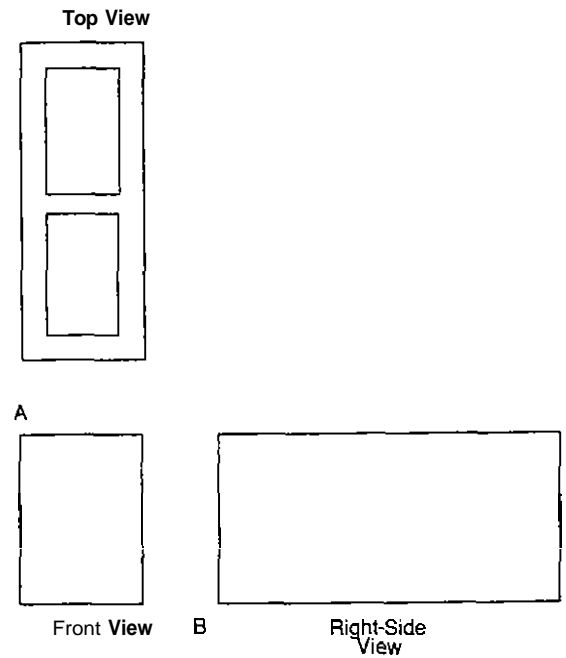

Fig. 2-6

On squared block paper, sketch the concrete block in three views as shown in Fig. 2-6. Use a straight edge and a medium-weight pencil. Note the equal spacing at "A" and "B." Save these sketches for future reference.

The drawing in Fig. 2-6 does not give a complete understanding of the object. Only the visible details in each view are shown.

In a three-view drawing, solid lines are used to represent the details of an object which can be seen in each view.

Broken lines are used to illustrate the openings which are "hidden" in the Front and Right-Side Views. See Fig. 2-7.

3

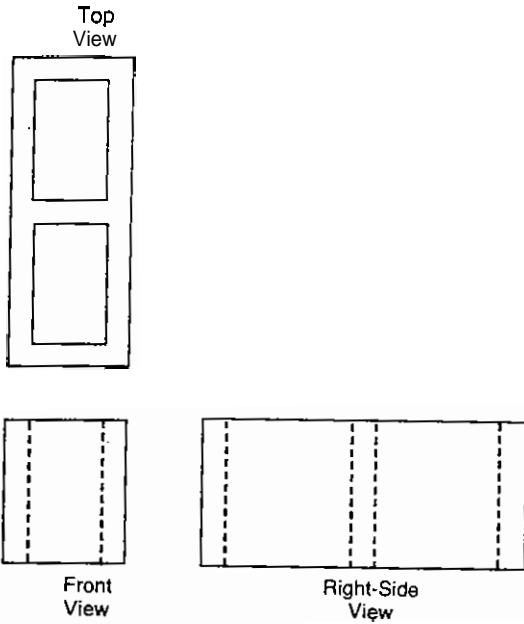

Fig. 2-7

The Front View, Top View, and the Right-Side View in Fig. 2-7 must be compared to get a true picture of the "hidden" details.

On squared block paper, make a **three-view** drawing of the concrete block with the Front View being what is normally considered as the front of the block. Compare your drawing with the one shown in Fig. 2-8.

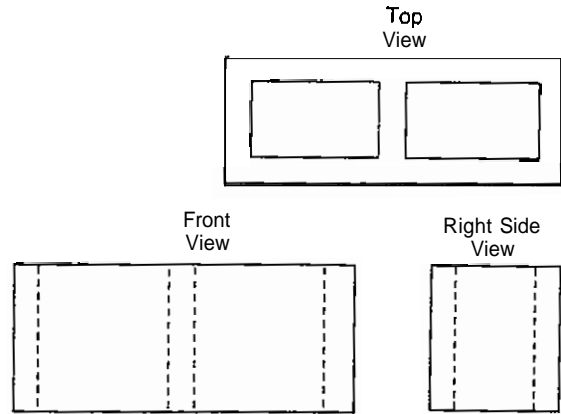

Fig. 2-8

Using the Top View shown in Fig. 2-8 as the Right-Side View, make a second sketch and compare it with Fig. 2-9.

The three-view drawings which have been discussed are generally accepted as standard in the United States and

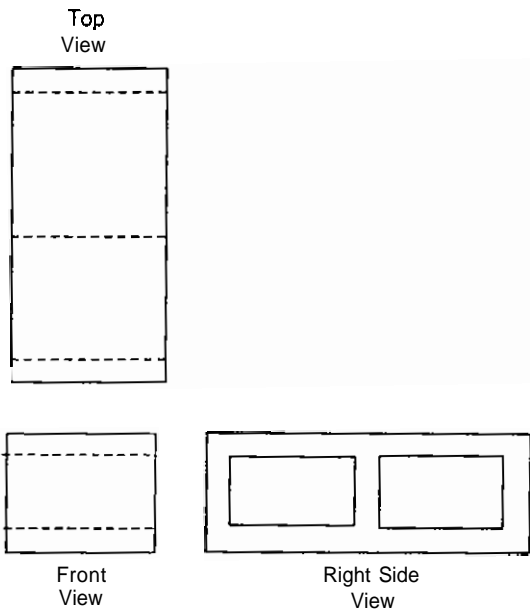

Fig. 2-9

Canada, but other views may be shown which would better illustrate the object. See Fig. 2-10.

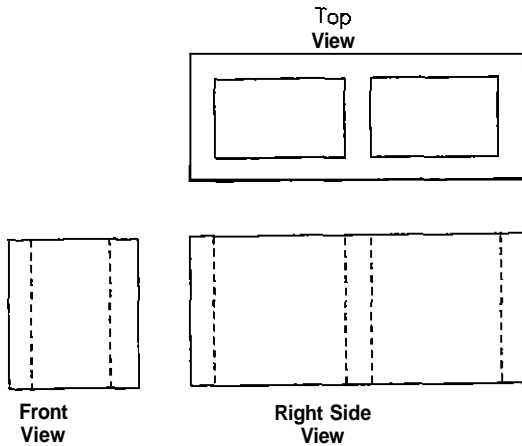

Fig. 2-10

The water closet shown in Fig. 2-11 is taken from an actual rough-in book.

The Front View of the drawing in Fig. 2-11 shows the left side of the fixture.

In Fig. 2-11, the left side of the fixture was chosen as the Front View because the left side of the fixture contains the ballcock and the rough-in could best be shown by this view.

The Top View of the fixture in Fig. 2-11 was omitted because the Front View, Right-Side View, and related notes provide sufficient information to rough-in this particular type water closet.

Technical drawings don't always show three views or all of the hidden lines and the exact outside shape of an object.

If space is at a premium, the draftsman may use symbols to represent objects such as valves or pipe fittings.

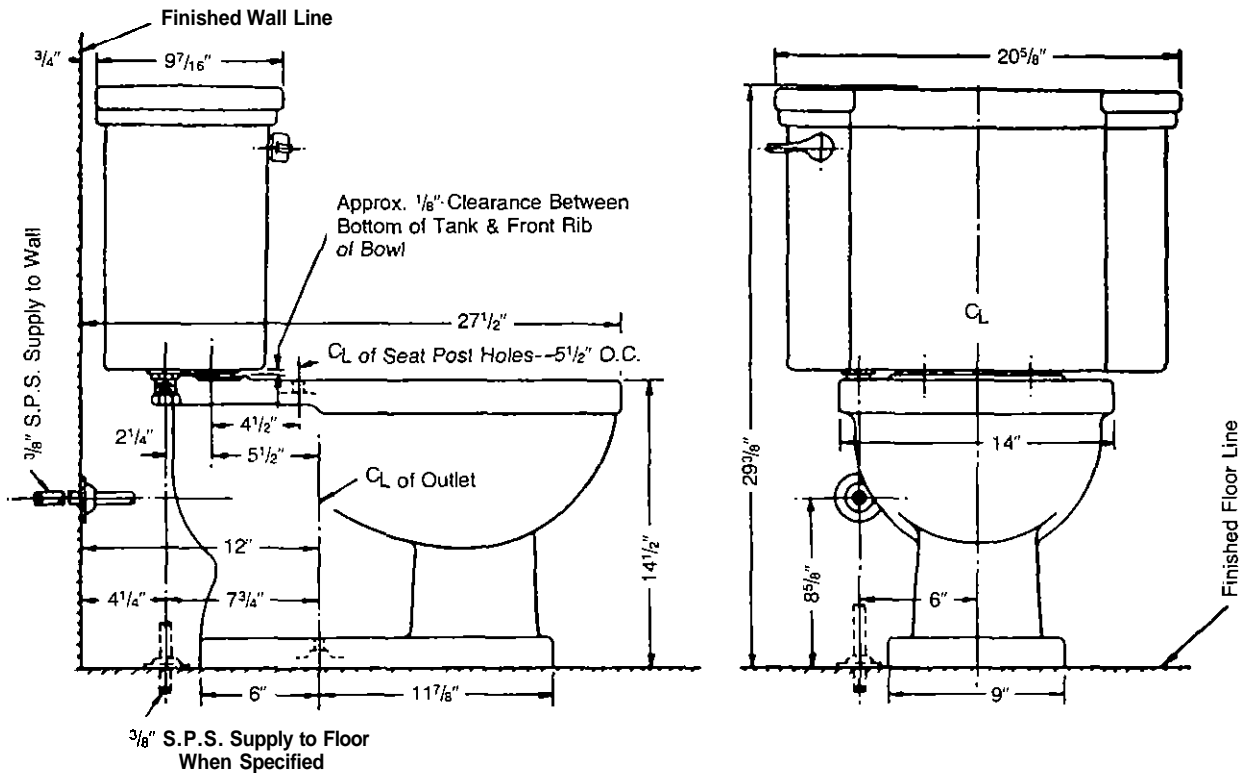

NOTE: This Water Closet is Designed to Rough-in at a Min. Dimension of 12" From Finished Wall to CL of Outlet

Fig. 2-11

Fig. 2-12-A, B and C are drawings of a 90° elbow shown in three views. An example of a 90° elbow is shown in Fig. 2-12-B and C using symbols.

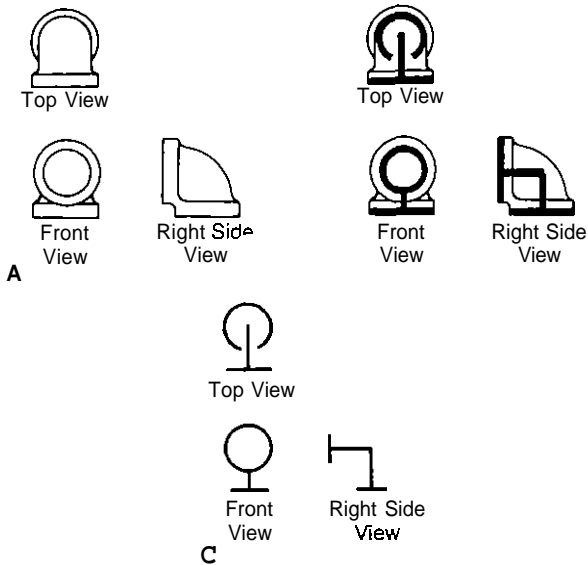

Fig. 2-12

In the process of making a drawing of a complicated piping system, the use of symbols similar to the types shown in Fig. 2-13 obviously saves time and space. You must know what these symbols stand for if you are to understand what the draftsman is trying to convey in a drawing.

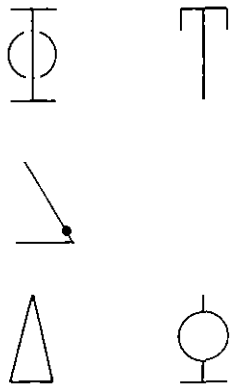

Fig. 2-13

Each symbol in Fig. 2-13 is both correctly identified and pictured by a double line drawing in Fig. 2-14.

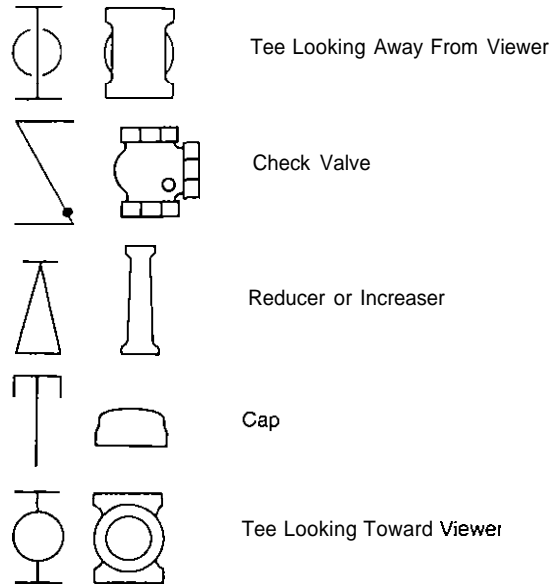

Fig. 2-14

On squared block paper, sketch a three-view drawing, using fitting symbols, to illustrate the piping arrangement shown in Fig. 2-15.

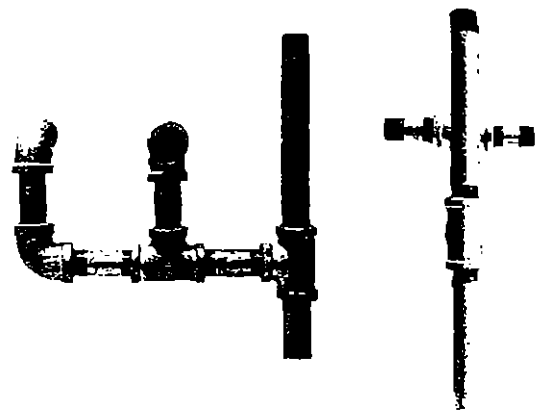

Fig. 2-15

Compare your sketch with the one shown in Fig. 2-16.

Explore Litigation Insights

Docket Alarm provides insights to develop a more informed litigation strategy and the peace of mind of knowing you're on top of things.

Real-Time Litigation Alerts



Keep your litigation team up-to-date with **real-time alerts** and advanced team management tools built for the enterprise, all while greatly reducing PACER spend.

Our comprehensive service means we can handle Federal, State, and Administrative courts across the country.

Advanced Docket Research



With over 230 million records, Docket Alarm's cloud-native docket research platform finds what other services can't. Coverage includes Federal, State, plus PTAB, TTAB, ITC and NLRB decisions, all in one place.

Identify arguments that have been successful in the past with full text, pinpoint searching. Link to case law cited within any court document via Fastcase.

Analytics At Your Fingertips



Learn what happened the last time a particular judge, opposing counsel or company faced cases similar to yours.

Advanced out-of-the-box PTAB and TTAB analytics are always at your fingertips.

API

Docket Alarm offers a powerful API (application programming interface) to developers that want to integrate case filings into their apps.

LAW FIRMS

Build custom dashboards for your attorneys and clients with live data direct from the court.

Automate many repetitive legal tasks like conflict checks, document management, and marketing.

FINANCIAL INSTITUTIONS

Litigation and bankruptcy checks for companies and debtors.

E-DISCOVERY AND LEGAL VENDORS

Sync your system to PACER to automate legal marketing.