

[54] SYSTEM FOR UNIFORMLY ILLUMINATING LIQUID CRYSTAL DISPLAY BOARD FROM REAR SIDE

[76] Inventor: Tatsuji Mizobe, 1-21-3, Sugano, Ichikawa-Shi, Chiba-Ken, Japan

[21] Appl. No.: 541,944

[22] Filed: Jun. 22, 1990

[51] Int. Cl.⁵ F21V 8/00

[52] U.S. Cl. 362/26; 362/27; 362/31; 362/331

[58] Field of Search 362/31, 26, 27, 331, 362/812, 311; 40/546

[56] References Cited

U.S. PATENT DOCUMENTS

3,328,570	6/1967	Balchunas	362/31
4,096,550	6/1978	Boller et al.	362/31
4,642,736	2/1987	Masuzawa et al.	362/31
4,714,983	12/1987	Lang	362/31
4,729,067	3/1988	Ohe	362/31
4,860,171	8/1989	Kojima	362/31

Primary Examiner—Ira S. Lazarus
Assistant Examiner—Sue Hagarman
Attorney, Agent, or Firm—Cushman, Darby & Cushman

[57] ABSTRACT

A system for uniformly illuminating a liquid crystal

display board from the rear side includes a main body as an essential component. The main body includes a transparent substrate made of transparent resin, a first coated layer on the front surface of the transparent substrate made of transparent resin having a refractive index different from that of the transparent substrate, a second coated layer on the rear surface of the transparent substrate made of transparent resin having a refractive index different from that of the transparent substrate and a rugged layer on the second coated layer made of transparent resin suitably employable for forming an underlying layer. A plurality of light sources each in the form of a fluorescent lamp are arranged in the transparent substrate in a spaced relationship. The rugged layer has a number of light reflecting means in the form of concavities and convexities formed on the front surface of the rugged layer for the purpose of irregularly reflecting light from each fluorescent lamp. The light reflecting means are distributed with a density per unit area which is determined to increase in inverse proportion to a square of the distance as measured from each fluorescent lamp to keep brightness substantially uniform over the whole surface of the transparent substrate.

8 Claims, 2 Drawing Sheets

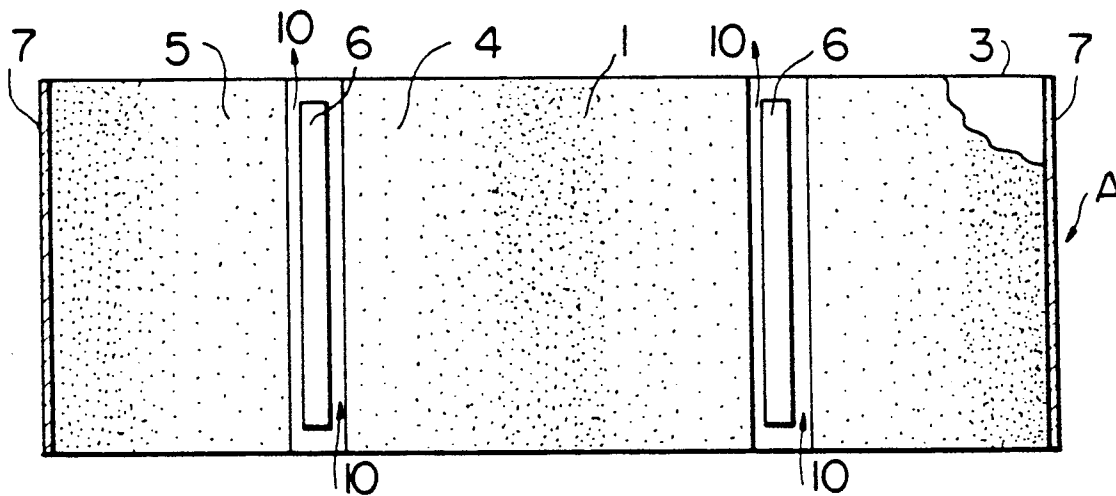

FIG. 1

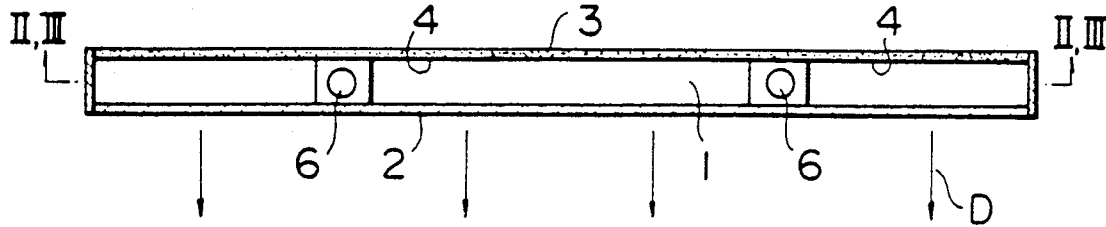

FIG. 2

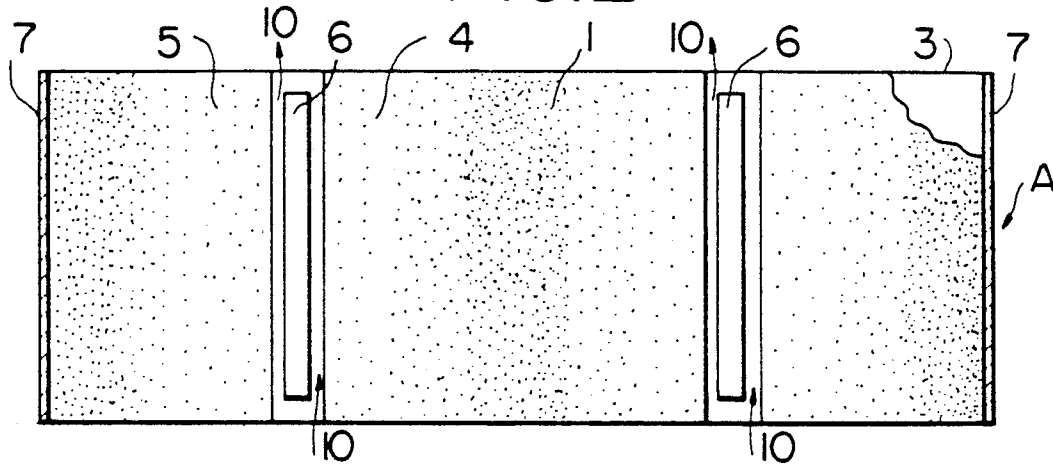

FIG. 3

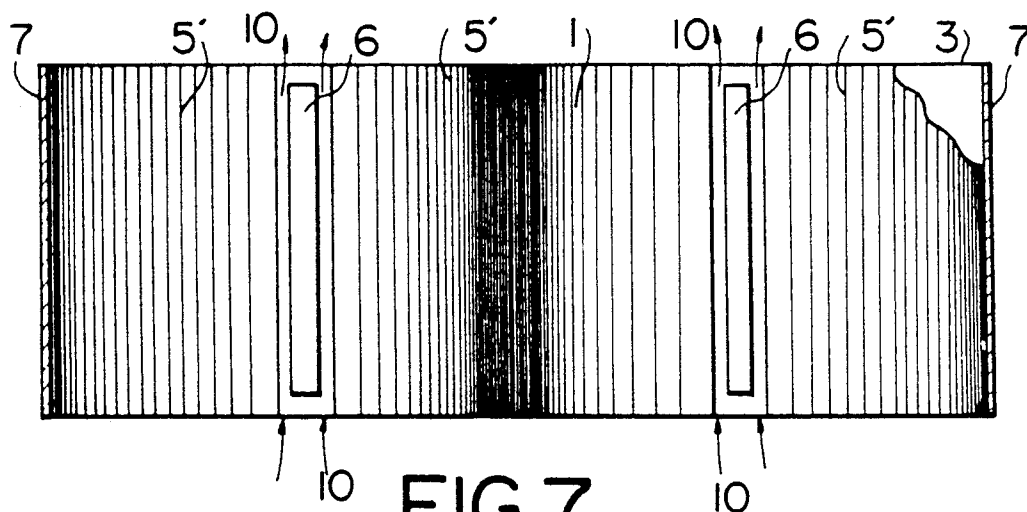

FIG. 7

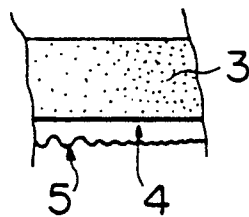

FIG.4

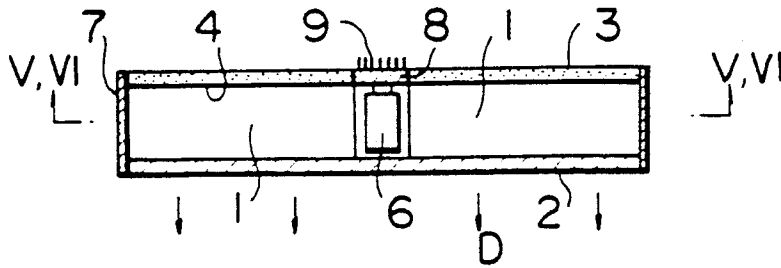

FIG.5

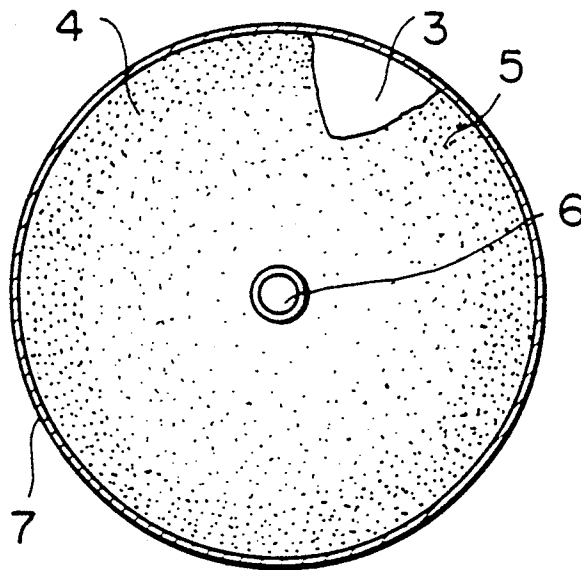
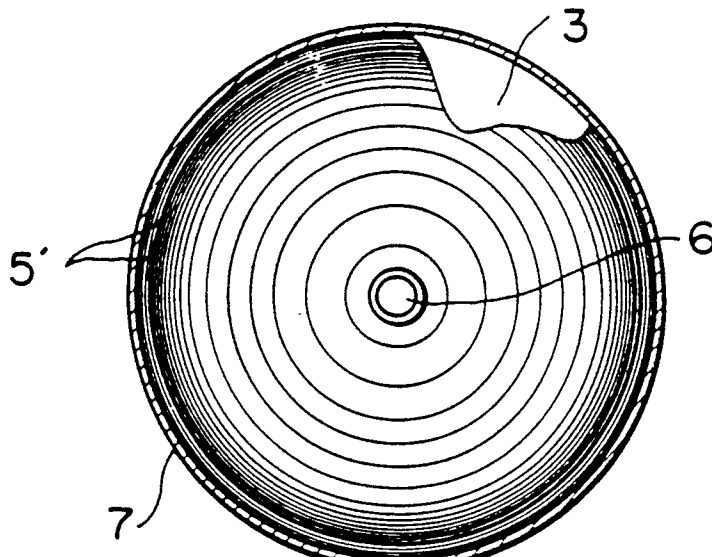

FIG.6



SYSTEM FOR UNIFORMLY ILLUMINATING LIQUID CRYSTAL DISPLAY BOARD FROM REAR SIDE

BACKGROUND OF THE INVENTION

1. Field of the Invention

The present invention relates to a system for uniformly illuminating a liquid crystal display board from the rear side wherein a parallel light beam is emitted in the form of reflected light from a main body located behind the liquid crystal display board with substantially uniform brightness over the whole surface of the screen of the liquid crystal display board.

2. Description of the Prior Art

In recent years, a number of liquid crystal display boards have been increasingly used for word processors, personal computers and so forth to display characters, numerals or the like with a high degree of resolution. To practically activate the liquid crystal display board, a plurality of large scale integrated circuits are incorporated in a work station for each word processor or personal computer.

With the conventional liquid crystal display board practically used in that way, it has been found that the liquid crystal display board has the following drawbacks.

Although the liquid crystal display board has a high degree of resolution, it is not easy to allow brightness to be substantially uniformly distributed over the whole surface of the liquid crystal display board. In practice, brightness decreases more and more in inverse proportion to a square of the distance as measured from a light source with the result that characters, numerals or the like on the screen of the liquid crystal display board are not uniformly visually recognized by an operator who is sitting in front of the word processor, personal computer or the like.

To assure that characters, numerals or the like on the screen of the liquid crystal display board are more clearly recognized by the operator, a proposal has been made such that light generated by a lamp is reflected at a reflective mirror which is disposed behind the liquid crystal display board and of which surface is treated to a frosted plane so that a parallel light beam is emitted toward the liquid crystal display board from the reflective mirror. With this proposal, however, brightness is not satisfactorily uniformly distributed over the whole surface of the liquid crystal display board. In addition, it is not easy to provide a high degree of brightness for the screen of the liquid crystal display board with the aforementioned proposal. Moreover, arrangement of the reflective mirror has been accomplished at expensive cost.

SUMMARY OF THE INVENTION

The present invention has been made with the foregoing background in mind.

An object of the present invention is to provide a system for uniformly illuminating a liquid crystal display board from the rear side wherein brightness is uniformly distributed over the whole surface of the liquid crystal display board.

Another object of the present invention is to provide a system for uniformly illuminating a liquid crystal display board from the rear side wherein the system is constructed at inexpensive cost.

To accomplish the above objects, there is provided according to one aspect of the present invention a system for uniformly illuminating a liquid crystal display board from the rear side, wherein the system includes as an essential component a rectangular main body located behind the liquid crystal display board in a spaced relationship, the main body having a configuration substantially identical to that of the liquid crystal display board and including a rectangular transparent substrate made of transparent resin, a first coated layer deposited on the front surface of the transparent substrate with transparent resin, the first coated layer having a refractive index different from that of the transparent substrate, a second coated layer deposited on the rear surface of the transparent substrate resin, the second coated layer having a refractive index different from that of the transparent substrate, a rugged layer deposited on the second coated layer with transparent resin suitably employable for forming an underlying layer, the rugged layer including a number of light reflecting means in the form of concavities and convexities on the front surface of the rugged layer for irregularly reflecting light from each light source, the light reflecting means being distributed with a density per unit area which increases in inverse proportion to a square of the distance as measured from each light source to keep brightness substantially uniform over the whole surface of the transparent substrate, and a plurality of light sources for generating light to be irradiated in the interior of the transparent substrate.

The light reflecting means are formed in a dot-shaped pattern as viewed from the front side.

Alternatively, the light reflecting means may be formed in a straight line-shaped pattern as viewed from the front side.

Usually, a fluorescent lamp is employed for the respective light sources, and the fluorescent lamps are arranged in the transparent substrate in a spaced relationship.

Alternatively, four fluorescent lamps may be arranged along four sides of the transparent substrate.

Further, according to another aspect of the present invention, there is provided a system for uniformly illuminating a liquid crystal display board from the rear side, wherein the system includes as an essential component a circular main body located behind the liquid crystal display board in a spaced relationship, the main body having a configuration substantially identical to that of the liquid crystal display board and including a circular transparent substrate made of transparent resin, a first coated layer deposited on the front surface of the transparent substrate with transparent resin, the first coated layer having a refractive index different from that of the transparent substrate, a second coated layer deposited on the rear surface of the transparent substrate with transparent resin, the second coated layer having a refractive index different from that of the transparent substrate, a rugged layer deposited on the second coated layer with transparent resin suitably employable for forming an underlying layer, the rugged layer including a number of light reflecting means in the form of concavities and convexities on the front surface of the rugged layer for irregularly reflecting light from a light source, the light reflecting means being distributed with a density per unit area which increases in inverse proportion to a square of the distance as measured from the light source to keep brightness substantially uniform over the whole surface of the transparent

substrate, and a single light source disposed at the central part of the transparent substrate for generating light to be irradiated in the interior of the transparent substrate.

The light reflecting means are formed in a dot-shaped pattern as viewed from the front side.

Alternatively, the light reflective means may be formed in a concentric circular line-shaped pattern as viewed from the front side.

As the light sources are turned on, light is irradiated toward the light reflecting means in the transparent substrate. Irregularly reflected light is repeatedly reflected further in the transparent substrate between the coated layers, whereby a parallel light beam is emitted from the transparent substrate through the front coated layer. Since a density of distribution of the light reflecting means per unit is determined to increase in inverse proportion to a square of the distance as measured from each light source, brightness is substantially uniformly distributed over the whole surface of the screen of the liquid crystal display board with the result that characters, numerals or the like on the screen of the liquid crystal display board are clearly visually recognized by an operator.

Other objects, features and advantages of the present invention will become apparent from reading of the following description which has been made with reference to the accompanying drawings.

BRIEF DESCRIPTION OF THE DRAWINGS

The present invention is illustrated in the following drawings in which:

FIG. 1 is a sectional plan view of a main body for a system for uniformly illuminating a rectangular liquid crystal display board from the rear side in accordance with an embodiment of the present invention;

FIG. 2 is a vertical sectional view of the main body taken in along line II—II in FIG. 1, particularly illustrating a number of light reflecting means arranged in a dot-shaped pattern;

FIG. 3 is a vertical sectional view of the main body taken along line III—III in FIG. 1, particularly illustrating a number of light reflecting means arranged in a straight line-shaped pattern;

FIG. 4 is a sectional plan view of a main body for a system for uniformly illuminating a circular liquid crystal display board from the rear side in accordance with another embodiment of the present invention;

FIG. 5 is a vertical sectional view of the main body taken along line V—V in FIG. 4, particularly illustrating a number of light reflecting means arranged in a dot-shaped pattern;

FIG. 6 is a vertical sectional view of the main body taken along line VI—VI in FIG. 4, particularly illustrating a number of light reflecting means arranged in a concentric circular line-shaped pattern; and

FIG. 7 is a fragmentary enlarged sectional view of the main body for the system of the present invention.

DESCRIPTION OF THE PREFERRED EMBODIMENTS

Now, the present invention will be described in detail hereinafter with reference to the accompanying drawings which illustrate preferred embodiments thereof.

FIGS. 1 and 2 illustrate a system for uniformly illuminating a rectangular liquid crystal display board (not shown) from the rear side in accordance with an embodiment of the present invention. FIG. 1 is a sectional

plan view of the system and FIG. 2 is a vertical sectional view of the system taken in line II—II in FIG. 1. The system includes as an essential component a main body A in the form of a transparent plate and two lamps 6 arranged in the interior of the main body A each serving as a light source. The main body A is constructed in the following manner. Specifically, the main body A includes a thin transparent substrate 1 made of, e.g., acrylic resin or the like material having an excellent light permeability, and coated layers 2 and 3 are deposited on front and rear surfaces of the substrate 1. In addition, a rugged layer 4 having a large number of concavities and convexities formed on the front surface thereof is interposed between the rear surface of the transparent substrate 1 and the coated layer 3 by employing a coating process. Each of the concavities and the convexities is dimensioned within the range of 2 microns to 3 microns so that it can not visually be recognized by eyes of an operator who is sitting in front of the liquid crystal display board. Therefore, such concavities and convexities have no effect on the background as viewed in the thickness direction of the transparent substrate 1. In practice, the concavities and the convexities on the rugged layer 4 serve as light reflecting means identified by reference numeral 5. A density of distribution of the light reflecting means 5 per unit area is determined in inverse proportion to a square of the distance as measured from each stationary light source 6 to keep brightness substantially uniform over the whole surface of the transparent substrate 1.

In the shown embodiment of the present invention, the light reflecting means 5 are formed on the rugged layer 4 in a dot-shaped pattern as viewed from the front side by employing a conventional screen printing process or the like. After completion of the printing operation, the transparent substrate 1 having a number of light reflecting means 5 formed on the coated layer 3 is placed in a baking oven (not shown) so that the light reflecting means 5 are baked at a lower temperature in the oven. Thus, the light reflecting means 5 are immovably deposited on the coated layer 3 of the transparent substrate 1.

Usually, a fluorescent lamp is used for each light source 6. As is well known, the fluorescent lamp 6 has optical characteristics that brightness in the middle part is higher than that at opposite ends of the fluorescent lamp. As is apparent from FIG. 2, a density of the light reflecting means 5 per unit area is distributed in inverse proportion to a square of the distance as measured from the fluorescent lamp 6. To assure that brightness is substantially uniformly distributed over the whole surface of the transparent substrate 1, a density of distribution of the light reflecting means 5 per unit area is practically determined to increase in inverse proportion to a square of the distance as measured from each light source 6, as mentioned above. With such construction, when the liquid crystal display board is practically used, the fluorescent lamps 6 are turned on. Light is irradiated from the fluorescent lamps 6 in the interior of the transparent substrate 1 toward the light reflecting means 5. As light is irradiated in that way, irregularly reflected light is repeatedly reflected further in the interior of the transparent substrate 1 between the both coated layers 2 and 3, whereby correctly reflected light in the form of a parallel light beam as identified by an arrow mark D in FIG. 1 is emitted toward the liquid crystal display board from the transparent substrate 1 through the coated layer 2, while exhibiting substantially uniform

Explore Litigation Insights

Docket Alarm provides insights to develop a more informed litigation strategy and the peace of mind of knowing you're on top of things.

Real-Time Litigation Alerts



Keep your litigation team up-to-date with **real-time alerts** and advanced team management tools built for the enterprise, all while greatly reducing PACER spend.

Our comprehensive service means we can handle Federal, State, and Administrative courts across the country.

Advanced Docket Research



With over 230 million records, Docket Alarm's cloud-native docket research platform finds what other services can't. Coverage includes Federal, State, plus PTAB, TTAB, ITC and NLRB decisions, all in one place.

Identify arguments that have been successful in the past with full text, pinpoint searching. Link to case law cited within any court document via Fastcase.

Analytics At Your Fingertips



Learn what happened the last time a particular judge, opposing counsel or company faced cases similar to yours.

Advanced out-of-the-box PTAB and TTAB analytics are always at your fingertips.

API

Docket Alarm offers a powerful API (application programming interface) to developers that want to integrate case filings into their apps.

LAW FIRMS

Build custom dashboards for your attorneys and clients with live data direct from the court.

Automate many repetitive legal tasks like conflict checks, document management, and marketing.

FINANCIAL INSTITUTIONS

Litigation and bankruptcy checks for companies and debtors.

E-DISCOVERY AND LEGAL VENDORS

Sync your system to PACER to automate legal marketing.