



US005160195A

United States Patent [19]

[11] Patent Number: **5,160,195**

Miller

[45] Date of Patent: **Nov. 3, 1992**

[54] DISPLAY PANEL BACKLIGHTING SYSTEM

Attorney, Agent, or Firm—Lahive & Cockfield

[75] Inventor: Eric A. Miller, Allston, Mass.

[57] ABSTRACT

[73] Assignee: TigerMark, Allston, Mass.

[21] Appl. No.: 828,741

[22] Filed: Jan. 31, 1992

[51] Int. Cl.⁵ F21V 7/00

[52] U.S. Cl. 362/300; 362/223;
362/297; 362/427

[58] Field of Search 362/222, 223, 300, 297,
362/427

A display panel system includes a peripheral frame surrounding a translucent panel and an apparatus for backlighting the translucent panel. The backlighting apparatus includes a support arm hingedly connected to a light source. The support arm includes a gripping member, for securing the support arm to the peripheral frame for positioning the light source to radiate light through the translucent panel. In some embodiments, the backlighting apparatus further includes a reflector for reflecting stray light toward the translucent panel. The support arm is foldable against the light source to facilitate packing and shipping of the backlighting apparatus.

[56] References Cited

U.S. PATENT DOCUMENTS

- 4,335,421 6/1982 Modia et al. 362/223
- 4,404,619 7/1983 Ferguson 362/223

Primary Examiner—Carroll B. Dority

13 Claims, 3 Drawing Sheets

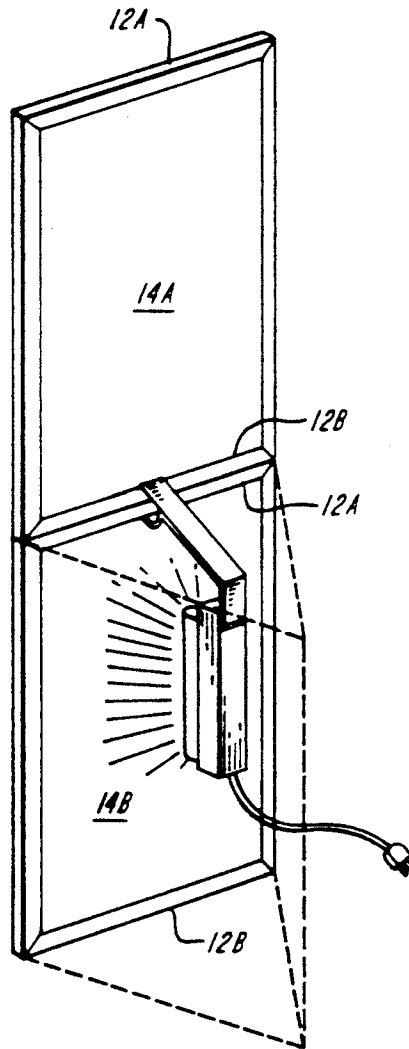

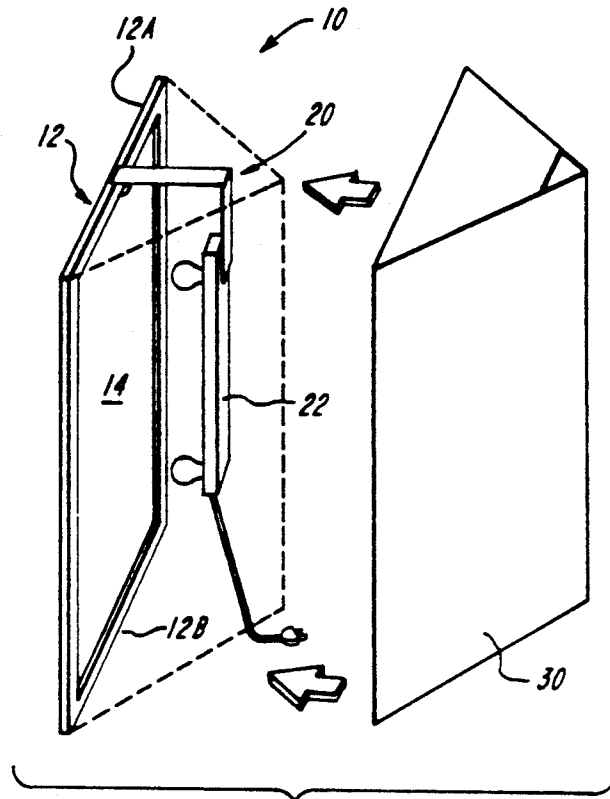

FIG. 1

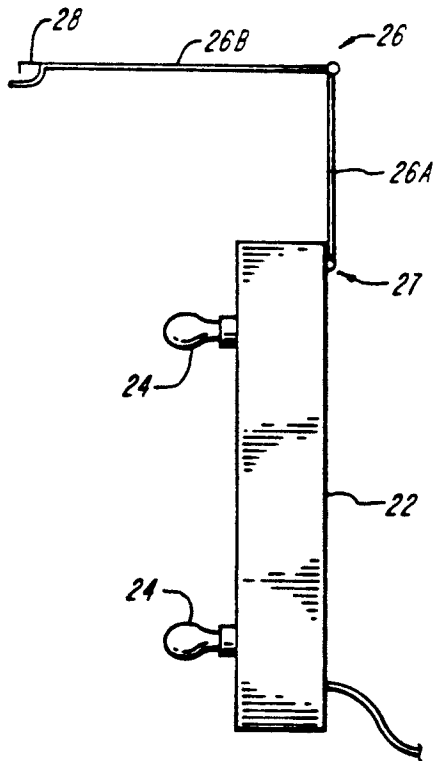

FIG. 2A

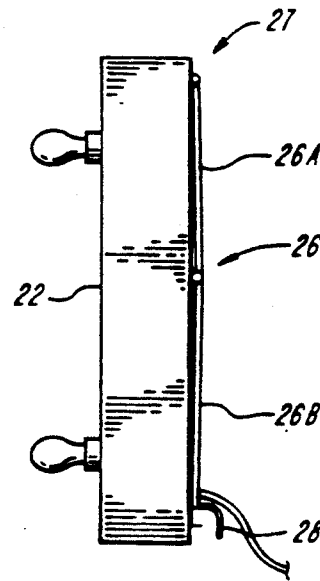

FIG. 2B

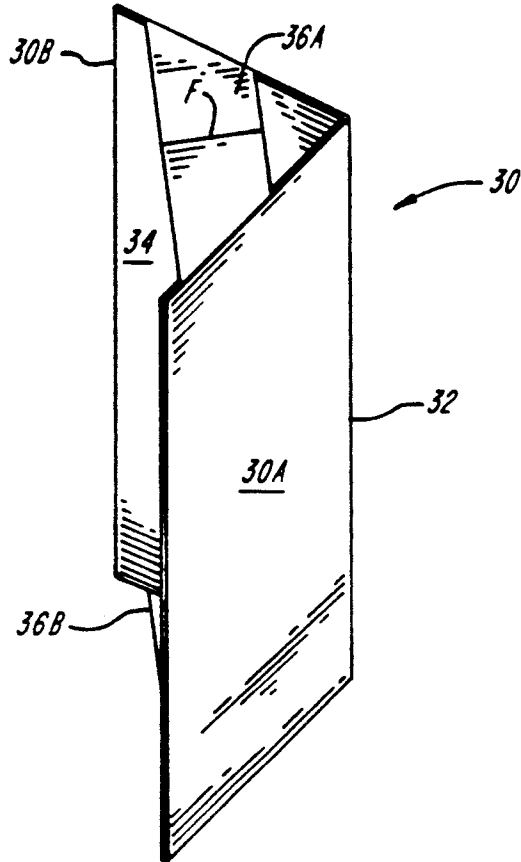

FIG. 3

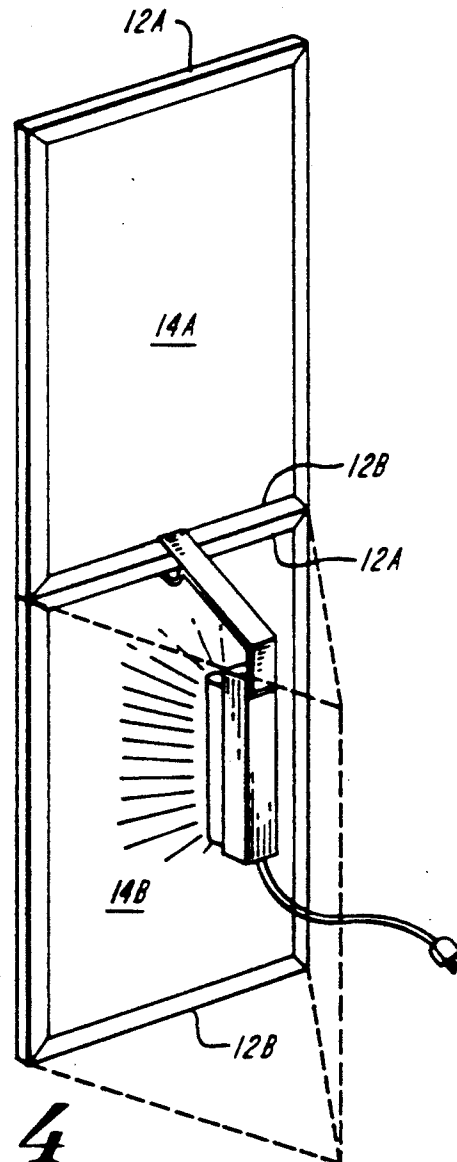

FIG. 4

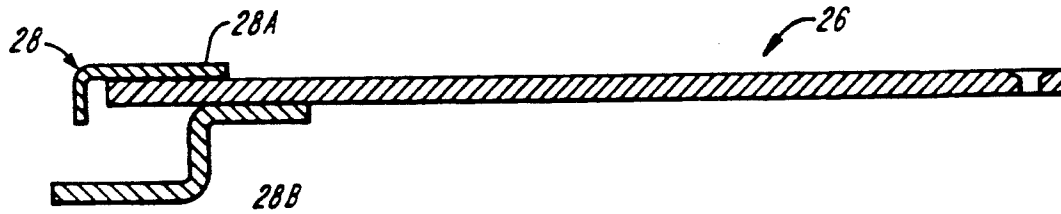

FIG. 5

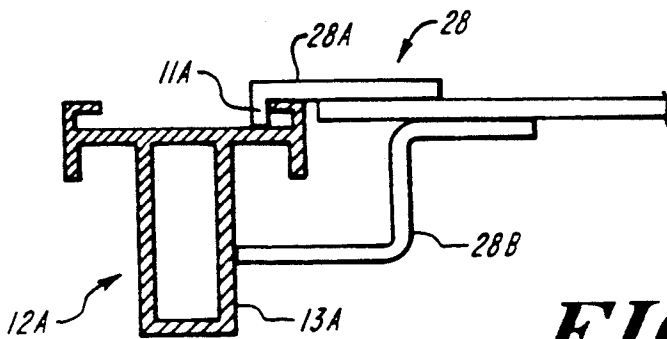

FIG. 6A

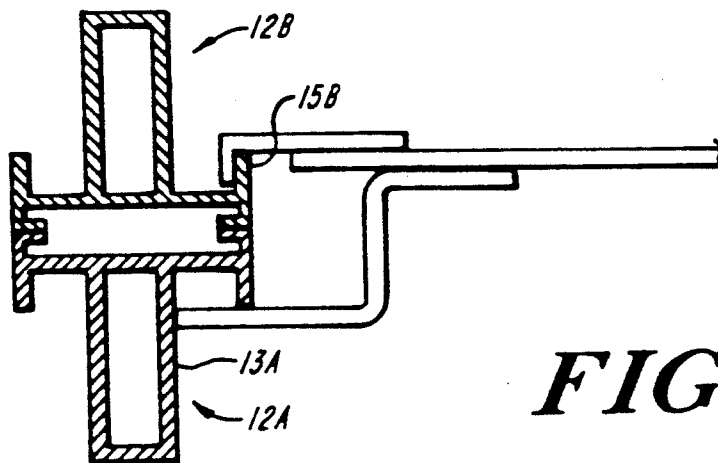

FIG. 6B

DISPLAY PANEL BACKLIGHTING SYSTEM

BACKGROUND OF THE INVENTION

The invention relates generally to the field of display panel systems. In particular, the invention concerns an apparatus for backlighting such a system.

Display panel systems, such as foldable display panel systems, serve an important marketing function at trade shows, retail installations, and other commercial venues. It has been estimated that at a trade show, a graphic display has less than five seconds to attract the attention of a potential customer. In this short time period, a message or image must be projected to make the customer want to acquire more information about the displayed product or service.

Studies have shown that backlitged images are up to three times more likely to be noticed than are reflectively lighted images. Indeed, various retailers have documented five to six times higher sales with the use of backlitged displays.

Backlighting systems currently available for use with display panel systems are heavy and bulky. Consequently, they consume large volumes of shipping space. This is critical in the case of travelling exhibitions which must constantly be set up, broken down, shipped to a new location, and set up again.

For example, one known system for backlighting a display panel includes a light box constructed of a plastic shell with a fluorescent light fixture attached to it. The shell is approximately four inches deep. When the fixture is completely assembled, it weighs approximately thirteen pounds.

Standard shipping cases for display panel systems are twelve inches by twenty-eight inches by forty inches. Known light boxes are packed back to back or opening to opening so that three light boxes require a twelve inch deep space. Accordingly, only three light boxes at a time can be shipped in standard shipping cases.

Another problem with known backlighting systems is "hot spots." Hot spots are bright spots which develop on backlitged graphic display panels because the backlighting source is positioned too closely to the back of the panel. When viewed from the front, these hot spots can distract a viewer from the image the display is designed to convey.

An object of the invention, therefore, is to provide a backlighting system for a display panel system which is easy to assemble and install. Another object of the invention is to provide such a system that occupies less shipping space than known systems. Still another object is to provide such a system that eliminates the problems of hot spots such as are associated with known backlighting systems. Yet another object is to provide a backlighting system that has a very finished look from the back of a display panel system.

SUMMARY OF THE INVENTION

These and other objects are achieved by the present invention which in one aspect features an improvement in a display panel system. The display panel system includes a peripheral frame which surrounds a translucent display panel. The improvement comprises a backlighting system including a light source and a support arm which is hingedly connected to the light source. The support arm includes securing means for securing the support arm to the peripheral frame. When the support arm is secured to the peripheral frame, the light

source is disposed at a distance from the back surface of the translucent panel for radiating light through the panel to evenly illuminate the front surface of the panel.

It is a significant feature of the invention that the support arm is hingedly connected to the light source. Accordingly, the support arm can be folded against the light source to provide a very compact structure for packing the system for storage or shipping.

A generally preferred, but optional feature of the inventive backlighting system is a reflector for reflecting light from the light source toward the translucent panel. This feature of the invention further serves to eliminate hot spots as viewed from the front of the panel. It also encloses light radiated by the light source and thereby provides the rear of the display panel system with a finished look.

A suitable reflector comprises at least two planar reflective elements hingedly connected to one another and connecting means for connecting to the peripheral frame. The reflective elements can be opened, in a tent-like configuration, and positioned on the rear of the display panel system. When not in use, the reflective elements can be folded together whereby they provide an extremely narrow profile for ease of packing and shipping.

In a particularly advantageous embodiment of this aspect of the invention, the reflector further includes two foldable end members attached to the planar reflective elements. The end members, typically trapezoid-shaped, prevent the reflective elements from opening too widely, and further enclose stray light to provide the back of the display panel system with an even more finished appearance.

These and other features of the invention will be more fully appreciated by reference to the following detailed description which is to be read in conjunction with the attached drawing.

BRIEF DESCRIPTION OF THE DRAWINGS

FIG. 1 is a perspective view of a panel display system utilizing a backlighting apparatus constructed in accordance with the teaching of the present invention.

FIGS. 2A and 2B are side views of a light strip and support arm suitable for use with the backlighting system shown in FIG. 1.

FIG. 3 is a perspective view of a reflector suitable for use with the backlighting system shown in FIG. 1.

FIG. 4 is a perspective view of another graphic panel display system utilizing a backlighting apparatus of the invention.

FIG. 5 is a plan view of a support arm suitable for use with the backlighting system shown in FIG. 4.

FIGS. 6A and 6B are partial cross-section views of two arrangements of the support arm shown in FIG. 1.

DETAILED DESCRIPTION

As stated above, in one aspect the invention features an improvement in a display panel system which includes a peripheral frame surrounding a translucent panel. The improvement features a backlighting apparatus for illuminating the front surface of the display panel from the rear.

FIG. 1 shows a typical display panel system 10 including a peripheral frame 12 and a translucent panel 14. In accordance with the teachings of the invention, the display system 10 further includes the improvement of a backlighting apparatus 20.

Explore Litigation Insights

Docket Alarm provides insights to develop a more informed litigation strategy and the peace of mind of knowing you're on top of things.

Real-Time Litigation Alerts



Keep your litigation team up-to-date with **real-time alerts** and advanced team management tools built for the enterprise, all while greatly reducing PACER spend.

Our comprehensive service means we can handle Federal, State, and Administrative courts across the country.

Advanced Docket Research



With over 230 million records, Docket Alarm's cloud-native docket research platform finds what other services can't. Coverage includes Federal, State, plus PTAB, TTAB, ITC and NLRB decisions, all in one place.

Identify arguments that have been successful in the past with full text, pinpoint searching. Link to case law cited within any court document via Fastcase.

Analytics At Your Fingertips



Learn what happened the last time a particular judge, opposing counsel or company faced cases similar to yours.

Advanced out-of-the-box PTAB and TTAB analytics are always at your fingertips.

API

Docket Alarm offers a powerful API (application programming interface) to developers that want to integrate case filings into their apps.

LAW FIRMS

Build custom dashboards for your attorneys and clients with live data direct from the court.

Automate many repetitive legal tasks like conflict checks, document management, and marketing.

FINANCIAL INSTITUTIONS

Litigation and bankruptcy checks for companies and debtors.

E-DISCOVERY AND LEGAL VENDORS

Sync your system to PACER to automate legal marketing.