



US006108060A

United States Patent [19]

[11] Patent Number: **6,108,060**

Funamoto et al.

[45] Date of Patent: **Aug. 22, 2000**

- [54] **SURFACE-TYPE ILLUMINATION DEVICE AND LIQUID CRYSTAL DISPLAY**
- [75] Inventors: **Tatsuaki Funamoto; Toru Yagasaki; Fumiaki Akahane**, all of Suwa, Japan
- [73] Assignee: **Seiko Epson Corporation**, Tokyo, Japan

5,057,974	10/1991	Mizobe	362/26
5,124,890	6/1992	Choi et al.	362/27
5,130,898	7/1992	Akahane	362/31
5,134,549	7/1992	Yokoyama	362/31
5,283,673	2/1994	Murase et al.	362/31
5,363,294	11/1994	Yamamoto et al.	362/26
5,764,493	6/1998	Liao	362/31
5,949,505	9/1999	Funamoto et al.	349/65

FOREIGN PATENT DOCUMENTS

- [21] Appl. No.: **09/321,687**
- [22] Filed: **May 28, 1999**

0 317 250	5/1989	European Pat. Off. .
0 442 529	8/1991	European Pat. Off. .
0 561 329	9/1993	European Pat. Off. .

(List continued on next page.)

Related U.S. Application Data

- [62] Division of application No. 08/689,424, Aug. 9, 1996, Pat. No. 5,949,505, which is a division of application No. 08/204,374, May 10, 1994, Pat. No. 5,619,351.

Foreign Application Priority Data

- May 13, 1993 [JP] Japan 5-111852
- [51] **Int. Cl.**⁷ **G02F 1/1335; G01D 11/28; F21V 7/04**
- [52] **U.S. Cl.** **349/65; 362/26; 362/27; 362/31**
- [58] **Field of Search** **349/65, 70; 362/26, 362/27, 31**

OTHER PUBLICATIONS

“Advancements In Backlighting Technologies For LCDs”, K. Hathaway, SPIE Proceedings, High-Resolution Displays and Projection Systems, vol. 1664, Feb. 1992, pp. 108-116. Electronic Design, Aug. 2, 1961, p. 47. Voltarc Technical Bulletin “Fluorescent Lamp”, 1987.

Primary Examiner—William L. Sikes
Assistant Examiner—Walter Malinowski
Attorney, Agent, or Firm—Mark P. Watson

References Cited

U.S. PATENT DOCUMENTS

3,892,959	7/1975	Pulles	362/31
3,968,584	7/1976	Kingston	362/31
4,568,179	2/1986	Durbin et al.	362/343
4,630,895	12/1986	Abdala, Jr. et al.	362/31
4,648,690	3/1987	Ohe	362/31
4,729,067	3/1988	Ohe	362/26
4,729,068	3/1988	Ohe	362/31
4,811,507	3/1989	Blanchet	362/31
4,842,378	6/1989	Flasck et al.	362/31
4,860,171	8/1989	Kojima	362/31
4,933,814	6/1990	Sanai	362/26
4,974,122	11/1990	Shaw	362/31
4,985,809	1/1991	Mitsui et al.	362/31

ABSTRACT

A surface-type illumination device suitable for providing backlight in a liquid crystal display is disclosed. For example, an L-shaped fluorescent light can be used as an illuminant and mounted next to two edges of a substantially rectangular light guide plate. The corner of an edge portion between the two edges is removed. The fluorescent light, the length of whose illuminating portion is long, is positioned with an appropriate gap from the light guide plate allowing for illumination with high brightness and low power consumption. Consequently, when the illumination device is used in a color liquid crystal display, appropriate backlight with high brightness can be obtained. Moreover, because the influence of the temperature from the illumination device is small, a stable color display can be achieved.

12 Claims, 12 Drawing Sheets

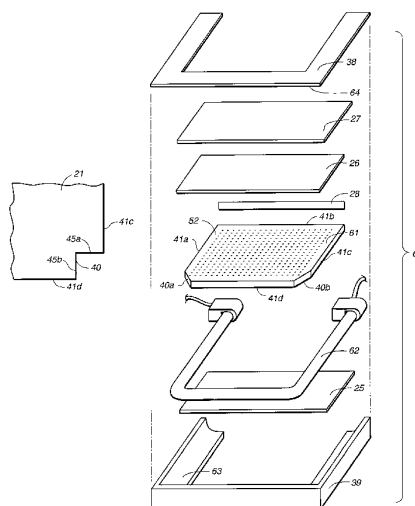

FOREIGN PATENT DOCUMENTS

0 587 766	4/1925	France .	63-45537	3/1988	Japan .
0 145 934	10/1957	France .	63-175301	7/1988	Japan .
0 327 493	5/1958	France .	63-124217	8/1988	Japan .
2 620 795	3/1989	France .	64-45002	2/1989	Japan .
2 632 432	12/1989	France .	64-45003	2/1989	Japan .
54-40086	3/1979	Japan .	1-183626	7/1989	Japan .
60-205576	10/1985	Japan .	3-15476	5/1991	Japan .
61-166585	7/1986	Japan .	3-201304	9/1991	Japan .
61-248079	11/1986	Japan .	4-102888	4/1992	Japan .
62-102226	5/1987	Japan .	0 664 193	1/1952	United Kingdom .
63-062105	3/1988	Japan .	WO88/08149	10/1988	WIPO .

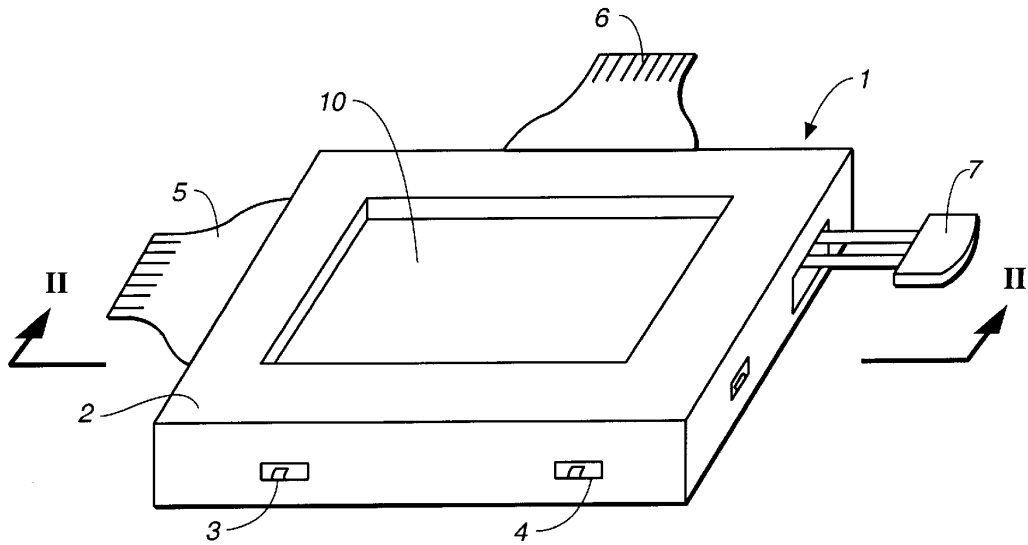

FIG. 1

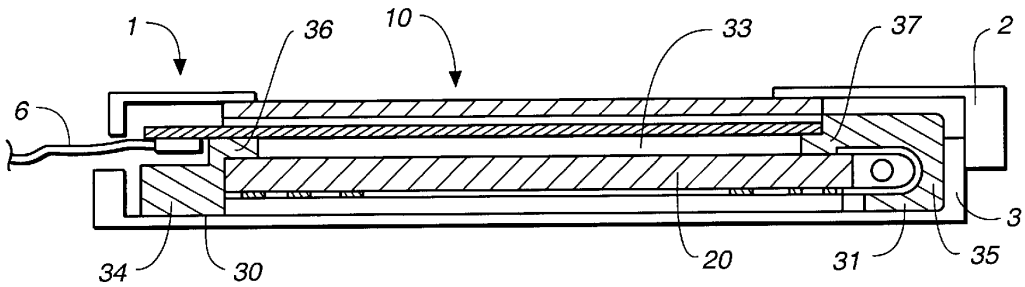

FIG. 2

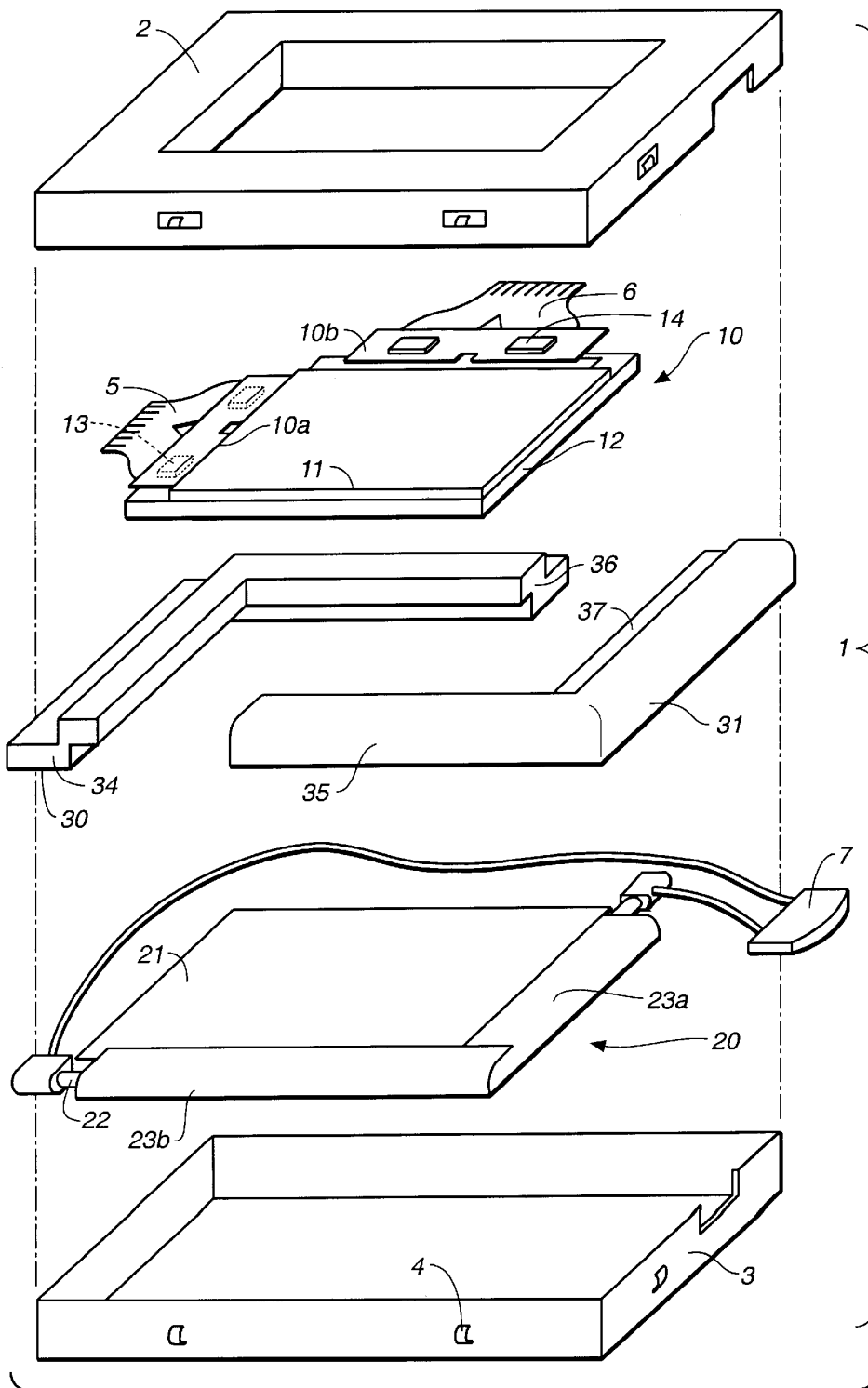

FIG. 3

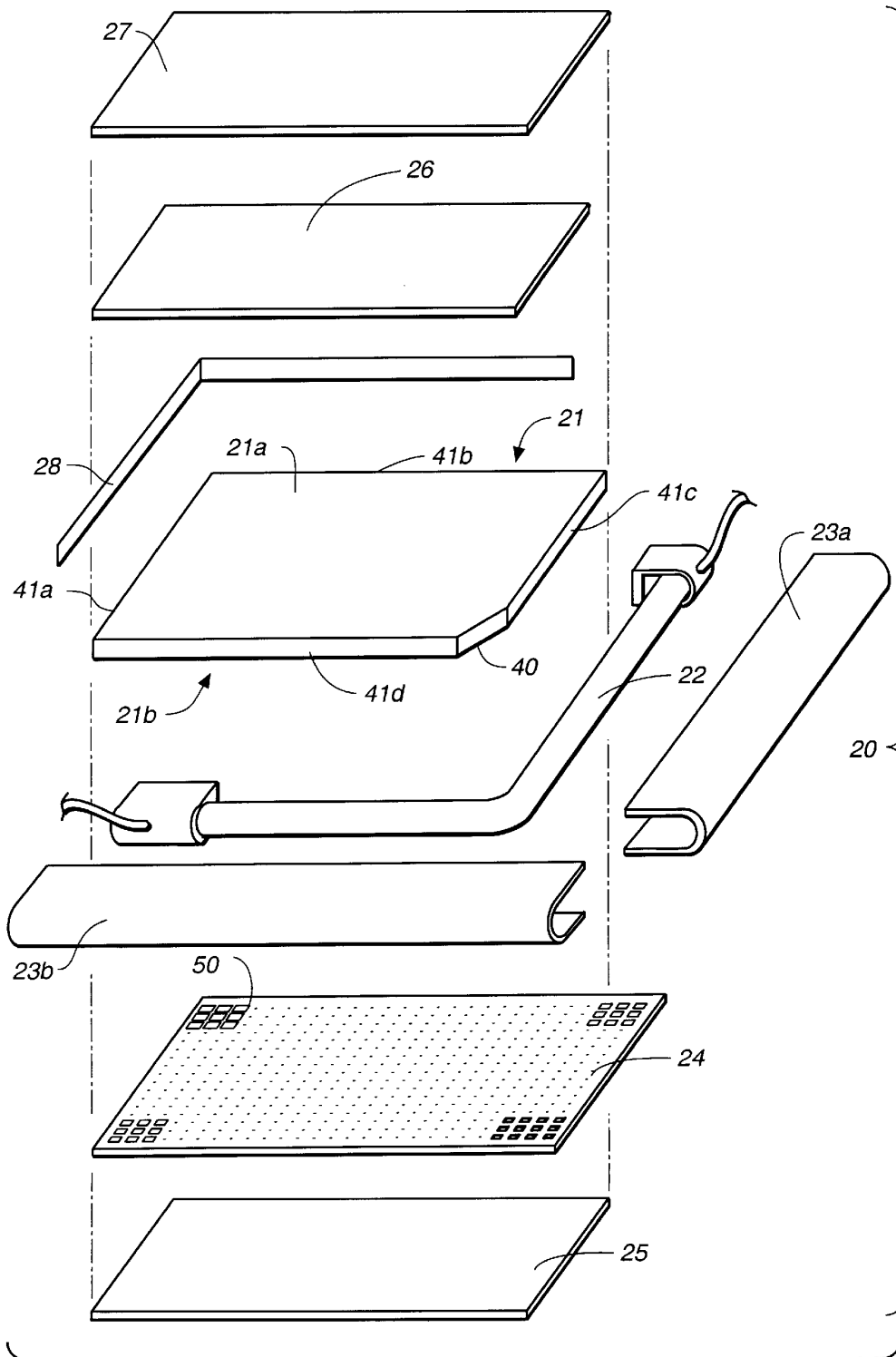

FIG._4

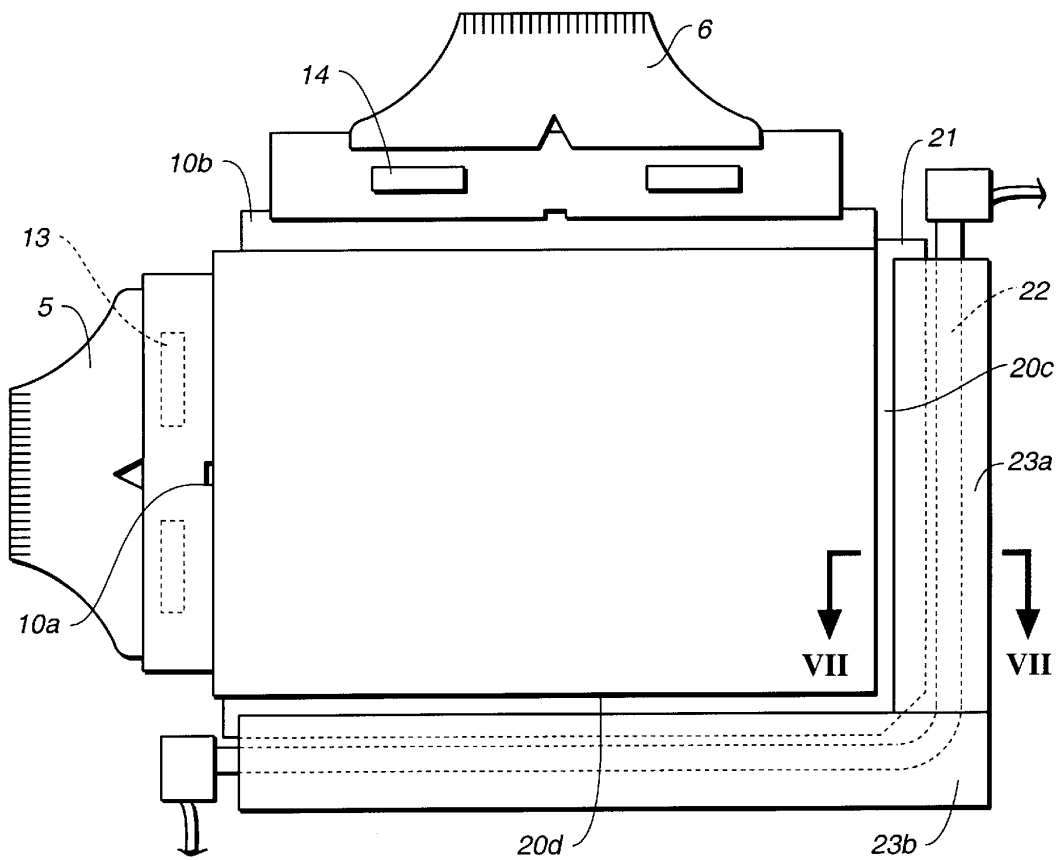

FIG._5

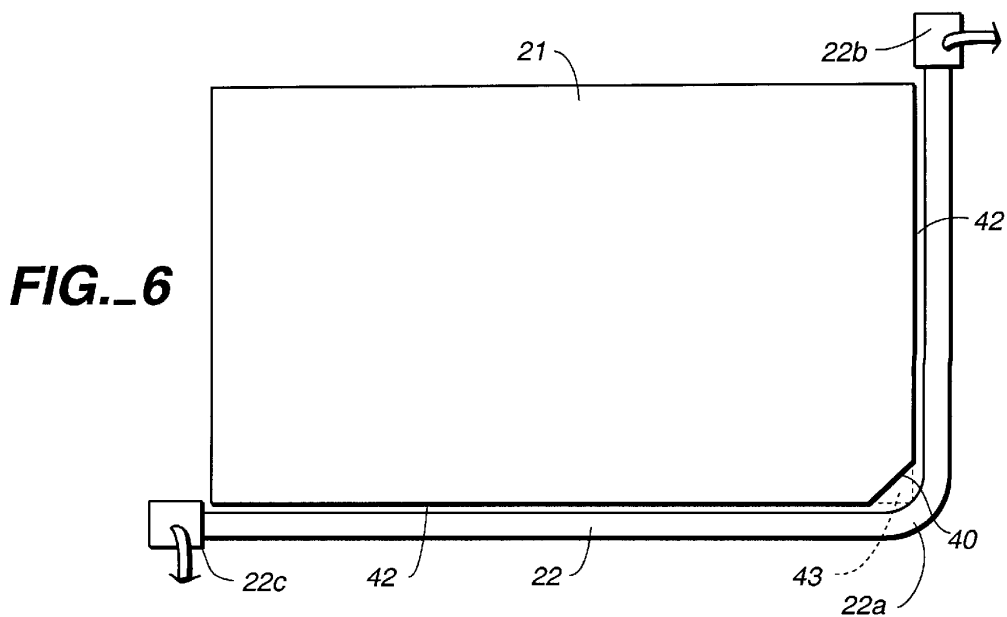

FIG._6

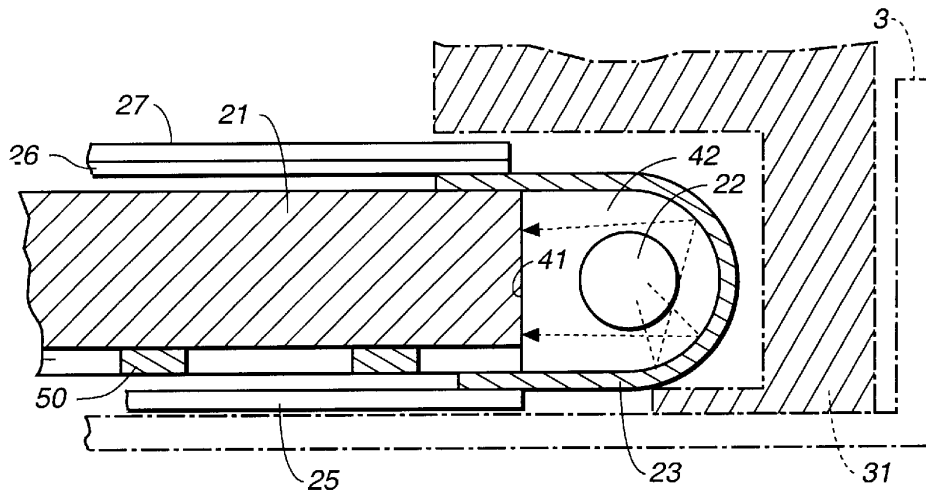

FIG. 7

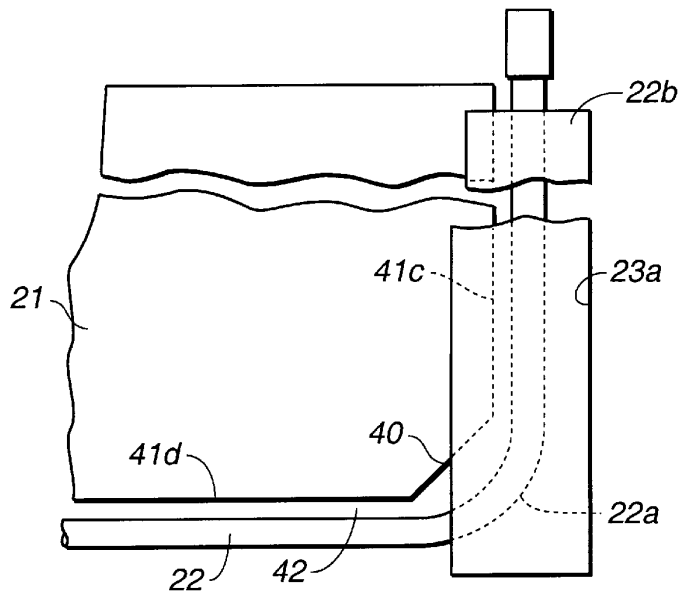

FIG. 8A

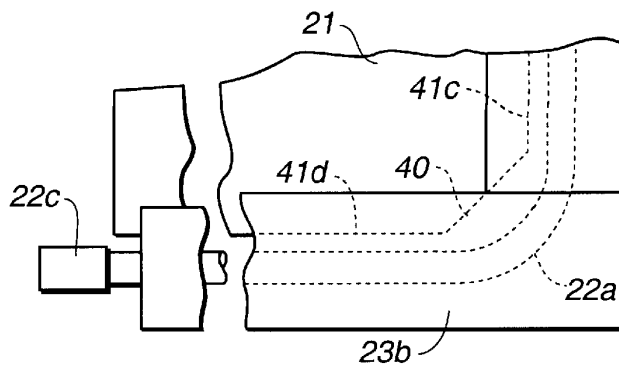

FIG. 8B

FIG._9

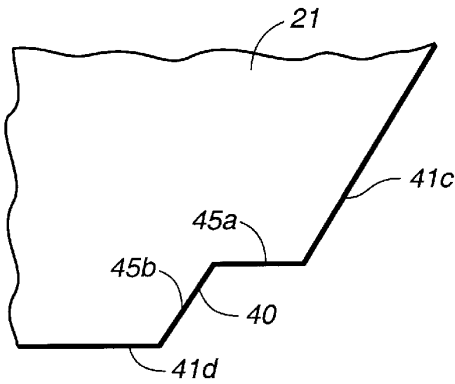
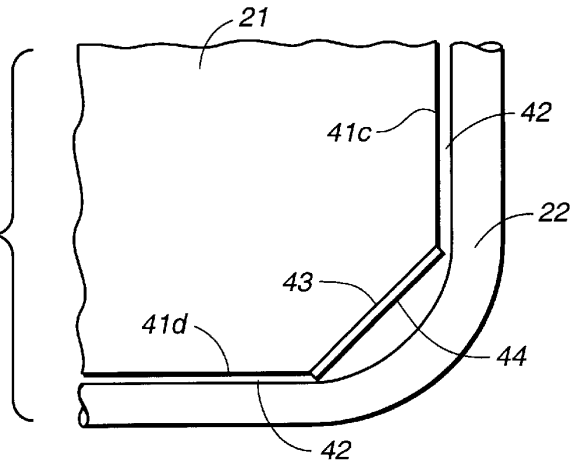

FIG._10A

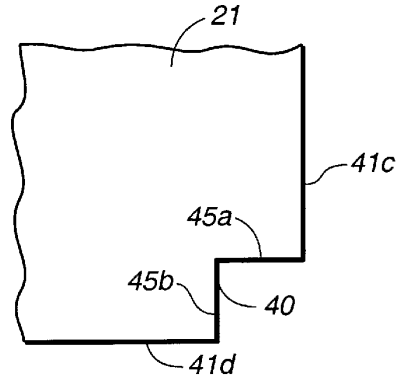

FIG._10B

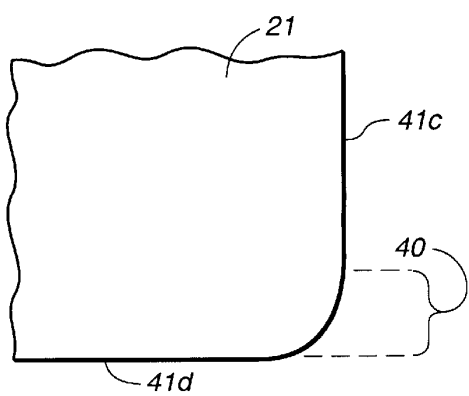

FIG._10C

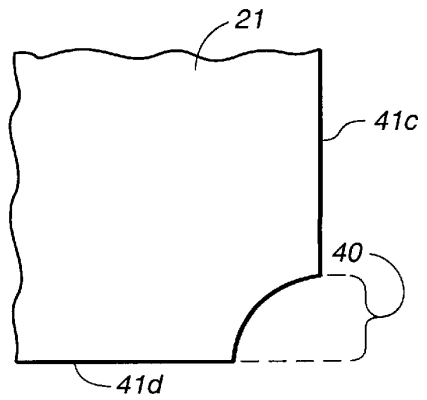

FIG._10D

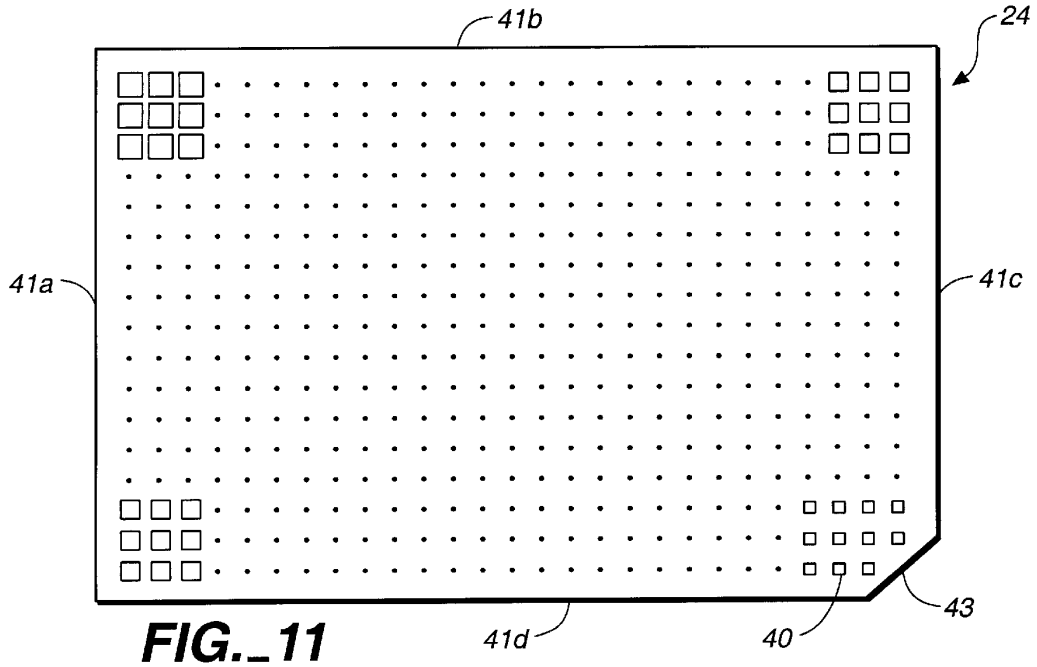

FIG. 11

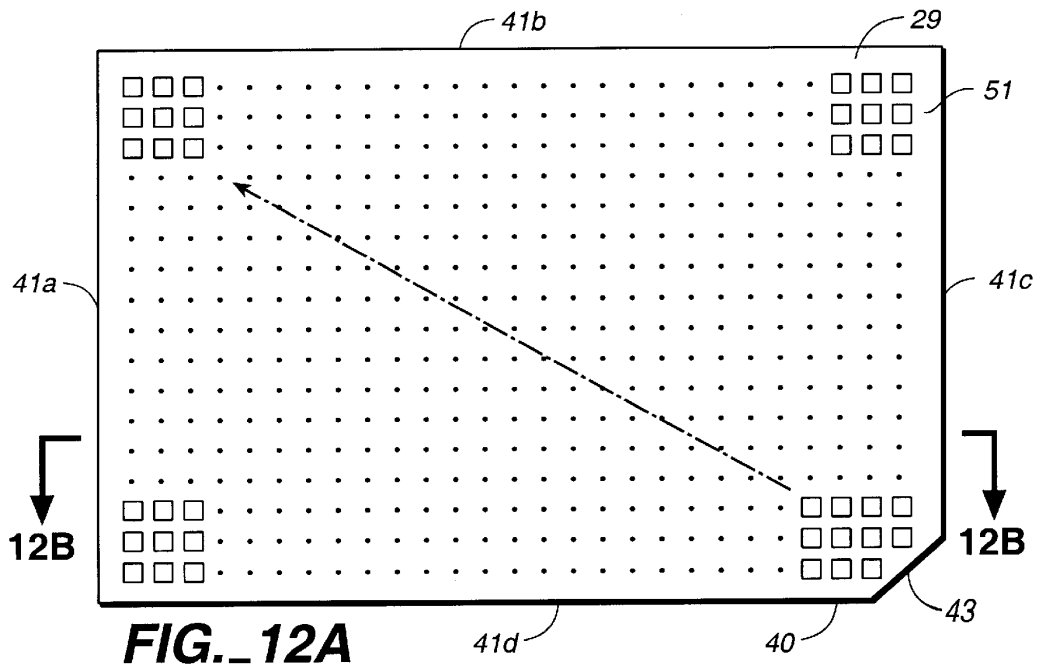

FIG. 12A

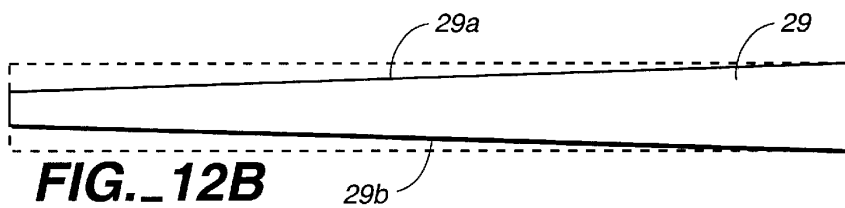

FIG. 12B

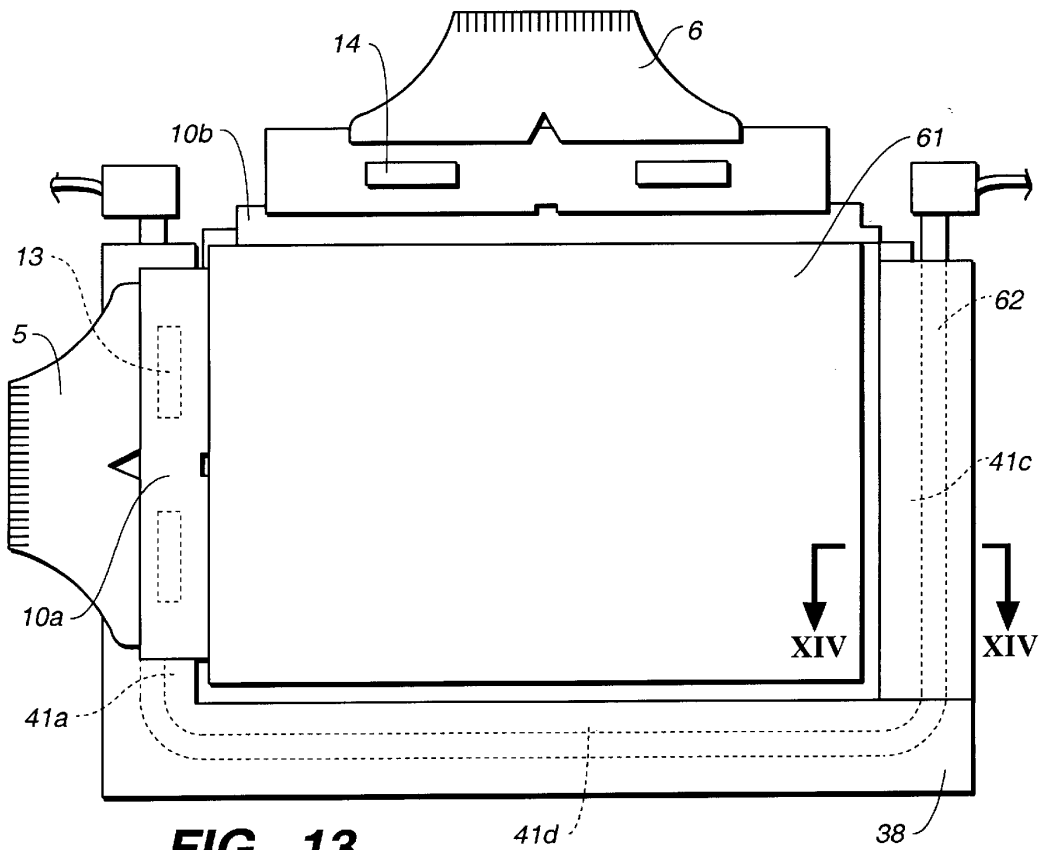

FIG. 13

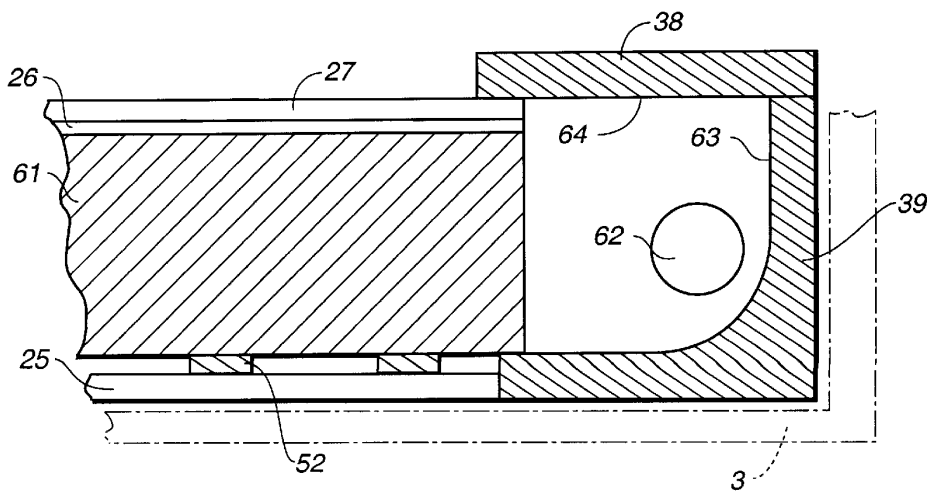

FIG. 14

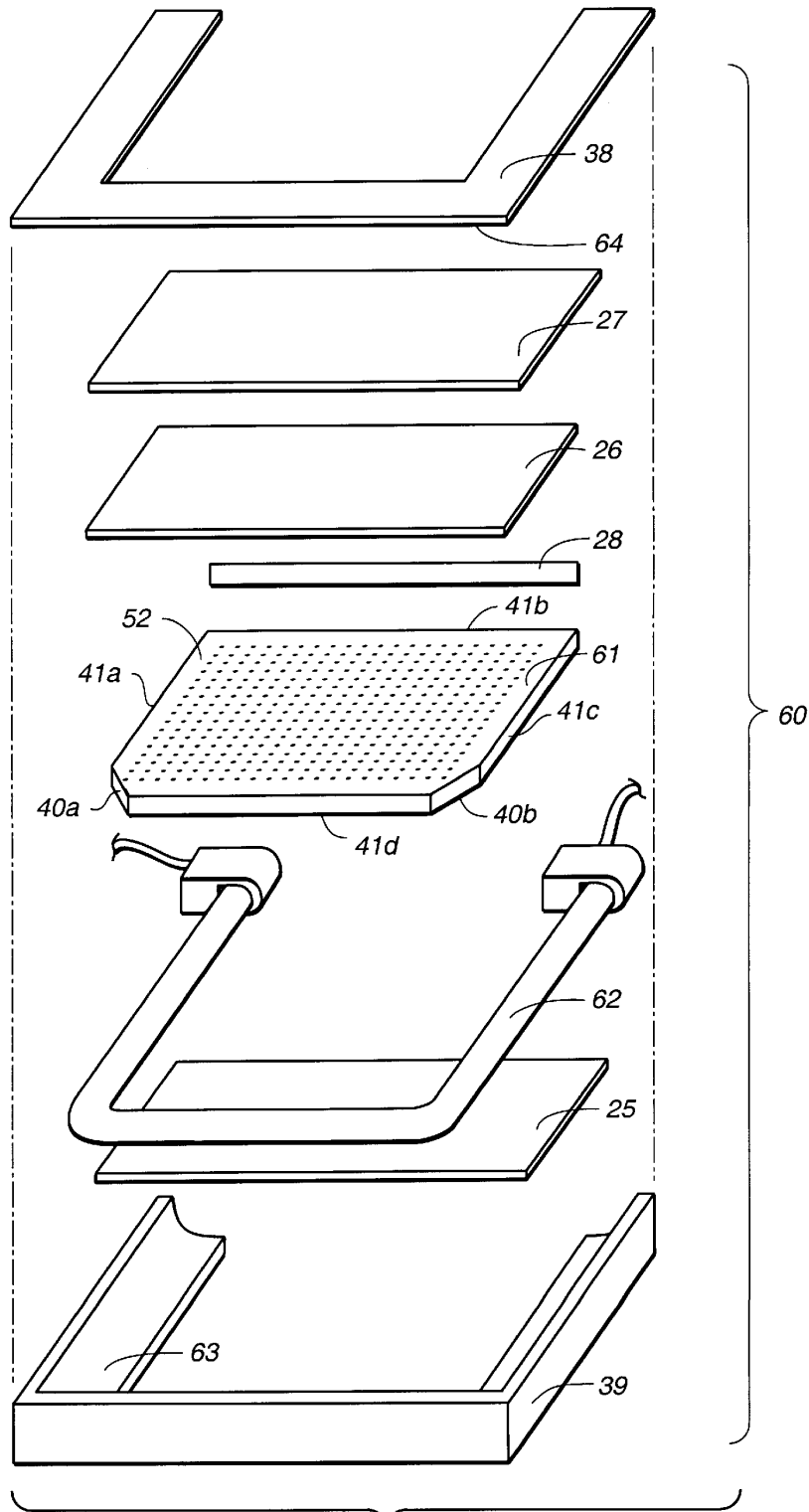

FIG. 15

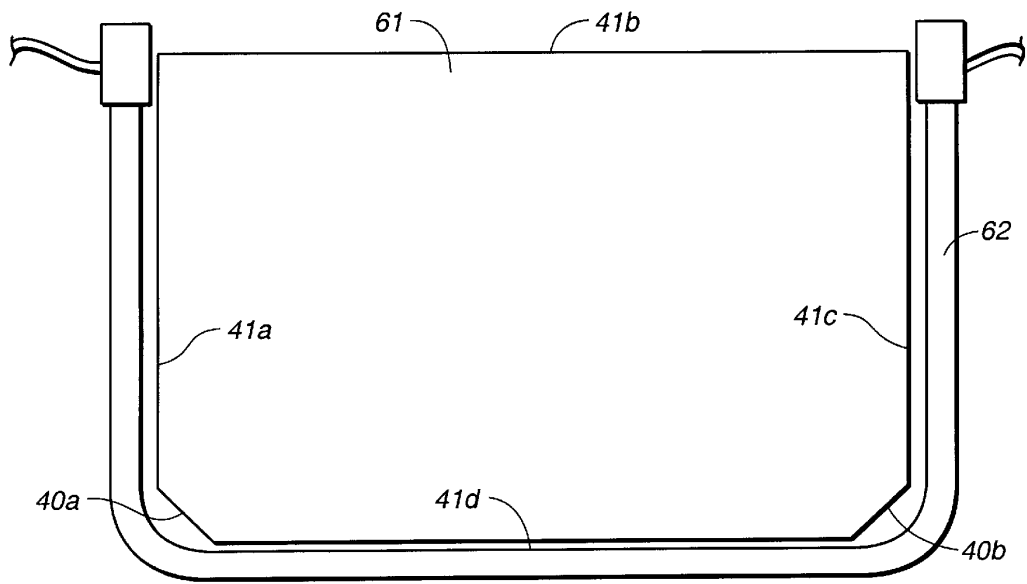

FIG. 16

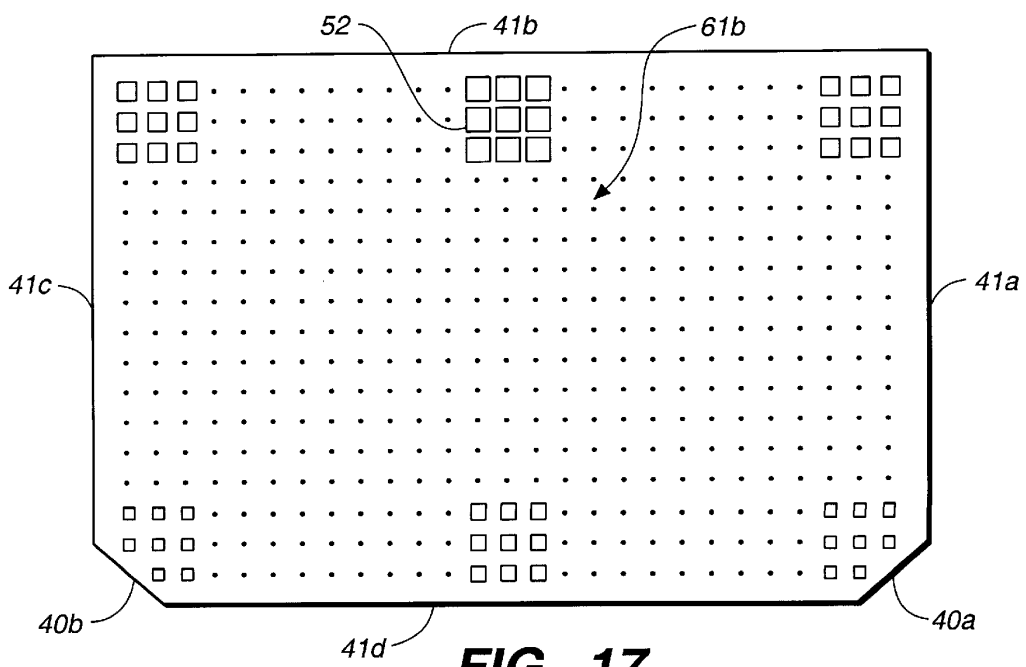

FIG. 17

FIG._18

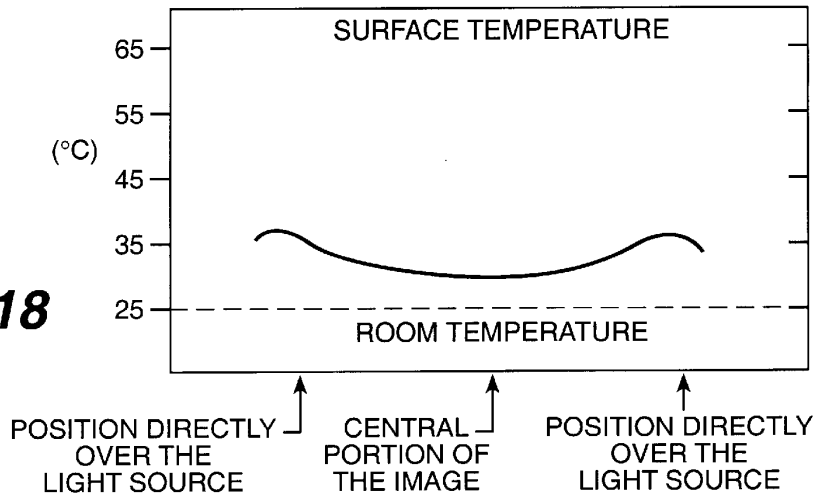

FIG._19

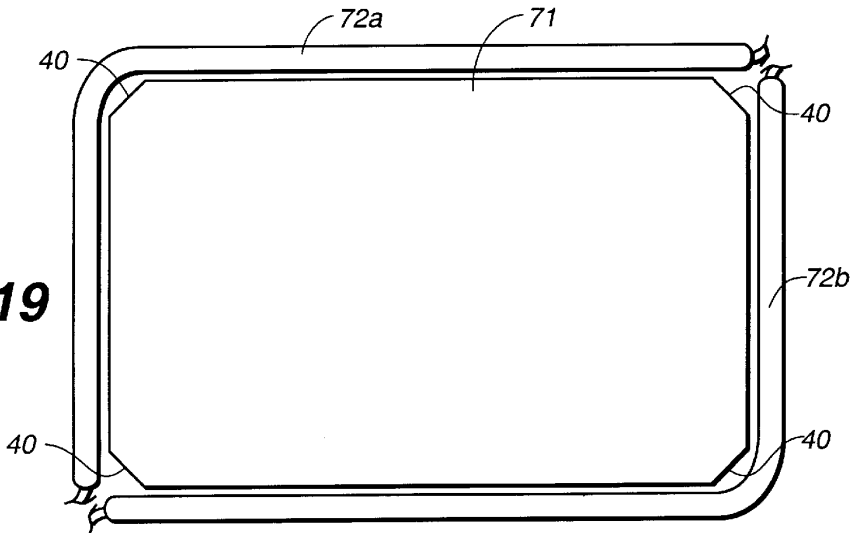
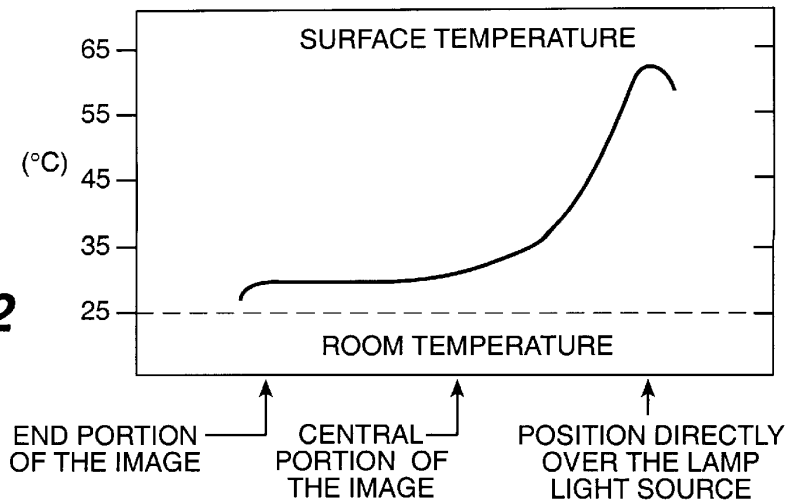

FIG._22



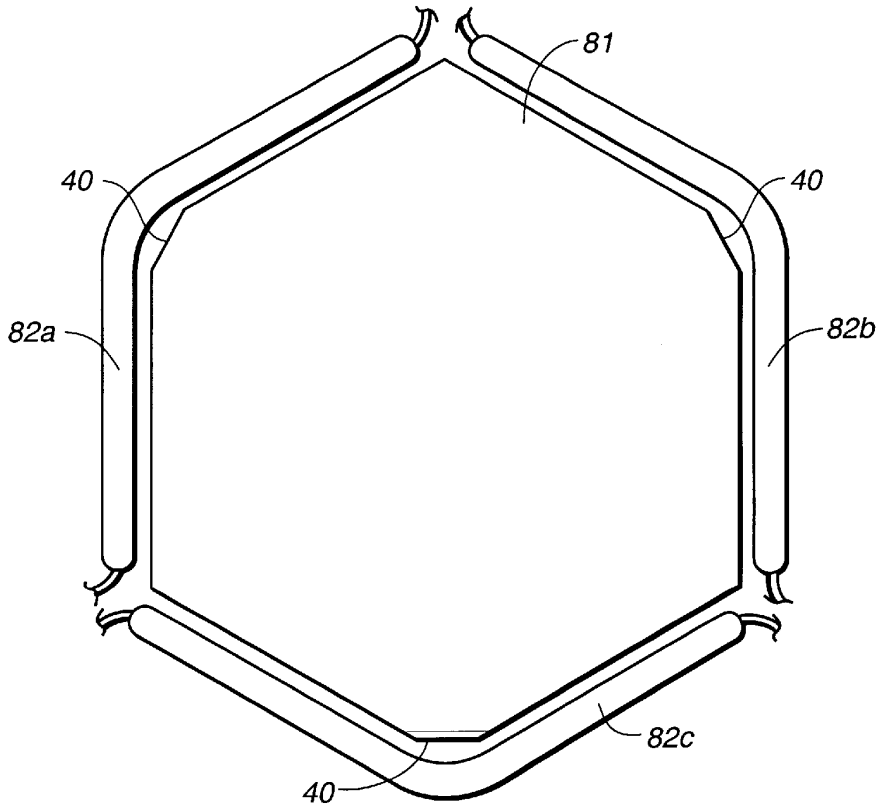

FIG. 20

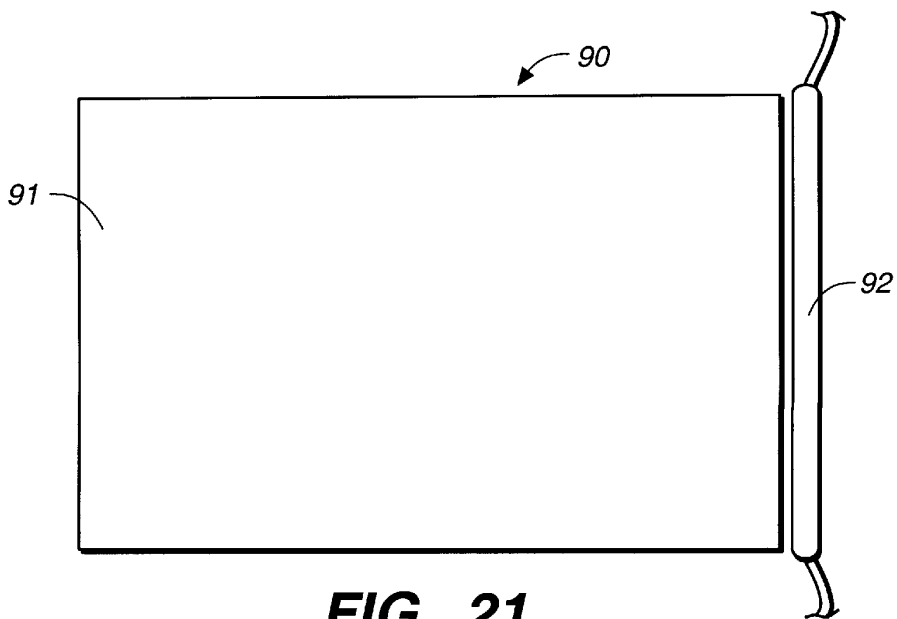

FIG. 21

SURFACE-TYPE ILLUMINATION DEVICE AND LIQUID CRYSTAL DISPLAY

CROSS-REFERENCE TO RELATED APPLICATIONS

This is a Divisional of prior application Ser. No. 08/689,424 filed Aug. 9, 1996, now U.S. Pat. No. 5,949,505, which is a Division of application Ser. No. 08/204,374 filed May 10, 1994, now U.S. Pat. No. 5,619,351. Application Ser. Nos. 08/689,424 and 08/204,374 are incorporated herein by reference in their entirety.

BACKGROUND OF THE INVENTION

This invention relates in general to a thin, surface-type illumination device for providing backlight for liquid crystal displays (LCD) and, in particular, to a suitable illumination device for use in a notebook computer display that provides high brightness with low power consumption as well as to a liquid crystal display that uses this illumination device.

Surface-type illumination devices with a cylindrical light source and a flat light guide plate such as the devices described in Japanese Laid-Open Patent Application No. 60-205576 and Japanese Laid-Open Patent Application No. 61-248079 are well-known. One such example is shown in FIG. 21. In the illumination device 90, cylindrical fluorescent light 92 is positioned on one side of the substantially rectangular and flat light guide plate 91. The light introduced to light guide plate 91 from fluorescent light 92 is reflected by the diffusion pattern printed on light guide plate 91 and emitted from the surface of the light guide plate at a fixed density of light.

This type of surface illumination device, in recent years, has been used extensively to provide backlight for liquid crystal display panels. Liquid crystal display panels are increasingly used as displays in such devices as laptop computers, televisions and cameras. The use of liquid crystal display panels for color displays is also increasing. As the size of personal computers and televisions become smaller, it is imperative that liquid crystal display panels become thinner and lighter.

Accordingly, it is necessary that the surface-type illumination device used for liquid crystal display panels to provide backlight, along with the color displays, becomes thinner and lighter with less power consumption. Also, to use in color displays, a sufficient brightness is necessary to clearly show the colors displayed in the liquid crystal. This requires the use of a high output fluorescent light in the illumination device. However, along with the light, heat is also radiated from the high-output fluorescent light. The effect of this heat, as shown in FIG. 22, is significant. The temperature may rise 30–40° C. above a normal temperature of 25° C. Consequently, when this type of illumination device is used for providing backlight in an MIM active color display panel or in an STN passive color display panel, a special method to reduce the heat is necessary to control, to a certain extent, the color and brightness irregularities.

Instead of using one high output fluorescent tube, one may also increase the number of fluorescent tubes. In this way, it is possible to control to some extent the temperature increase due to the light source. However, as the number of fluorescent tubes is increased, many other problems appear. One of these problems is the variations in the illumination of the fluorescent tubes. Because the illumination intensity of fluorescent tubes varies according to each tube, it is necessary to adjust such things as the resistance within the fluorescent tube driver circuit to obtain a fixed illumination intensity.

Consequently, in the case when several fluorescent tubes are used in one illumination device, extra time is required during the manufacturing process to obtain a balanced and fixed illumination intensity.

Another problem is the increased number of driver circuits required to turn on the fluorescent tubes. The number of these driver circuits can not be easily increased in devices such as microcomputers where thinness and small size are important.

SUMMARY OF THE INVENTION

In accordance with the instant invention, a suitable illumination device for color liquid crystal displays can be obtained that is small in size, lightweight, and has high and uniform brightness. Further, it is an object of the invention to provide a surface-type illumination device that can prevent heat generation and its resulting bad effects to the liquid crystal display panel.

Another object of the invention is to provide a surface-type illumination device that, without increasing the number of driver circuits for driving the fluorescent lights, displays a brightness higher than that in conventional illumination devices and restricts heat radiation.

A further object of the invention is to generate a suitable diffusion pattern to realize a surface-type illumination device, this diffusion pattern being used in the illumination device.

Still another object of the invention is to provide a stable liquid crystal display where the driver IC for driving the liquid crystal display panel is positioned so that it will not be affected by heat.

In accordance with the instant invention, by employing an illuminant longer than conventional illuminants, illumination with high illumination intensity is obtained without increasing the number of driver circuits for driving the illuminants and without concentrating the heat diffusion. Further, by bending the illuminant, light can be introduced along the polygon-shaped light guide plate. Also, to maintain proper space between the light guide plate and the illuminant and to increase the efficiency of the light introduced to the light guide plate, a corner is removed from an edge of the light guide plate. According to the invention, the surface-type illumination device comprises a light guide plate which is polygon-shaped and substantially transparent; a diffusion pattern arranged on one surface of the light guide plate for substantially evenly emitting light, the light being introduced from the illuminant to the other surface of the light guide plate; and a cylindrically-shaped illuminant bent so that the illuminant faces at least two sides of the light guide plate; wherein the edge between the two sides is processed so that the corner does not protrude.

By using an illuminant bent along the light guide plate, the length of the cylindrically-shaped illuminant is long, and an illuminant with large illuminating area can be used. Consequently, the rise in temperature of the illuminant can be kept down and high brightness can be obtained. Furthermore, the number of driver circuits for driving the illuminant can be decreased. When an illuminant such as a fluorescent light is bent to adjust for interference between the bent portion and the corner of the light guide plate, the width or length of the entire illumination device becomes longer, preventing miniaturization. In the instant invention, by removing a corner of the light guide plate, the distance between the light guide plate and the illuminant can be kept within a fixed range for high incident efficiency, and thus, a highly efficient illumination device that is small in size can be realized.

Further, by using a long illuminant as mentioned above, an improvement in the conversion efficiency from power to light is also attained. For example, in illuminants such as a fluorescent light, the power to the illuminant is consumed by the cathode drop, which is due to the glow discharge, and by positive column gradient voltage, which is due to light emission. When a plurality of illuminants are used and the input voltage increased, the portion consumed by the cathode drop voltage significantly increases and an increase in the positive column gradient tendency for light emission is small. However, in the illumination device of the instant invention, which uses a long illuminant, power is efficiently converted into light as the increase in the positive column gradient voltage is smaller than in the case when the number of illuminants is increased.

The edge of the light guide plate can be processed into many different shapes, for example, the corner in the shape of an isosceles triangle can be removed. In the case of the isosceles triangle, a high incident efficiency of light from the illuminant to the light guide plate can be maintained. It is desirable to make the length of one of the sides of the isosceles triangle in the approximate range of 0.6 times to 1.0 times the smallest radius of curvature of the bent portion of the illuminant so as to realize a small-sized illumination device. Also, in order to prevent light incident from the edge, and to increase the uniformity of the light radiated from the light guide plate, it is effective to include a shield at the edge portion to prevent introduction of light from the illuminant.

Also, the corner of the edge in a diamond-shape may be removed. In order to make the incident efficiency high and keep the size of the device small, it is desirable to make the length of one of the sides of the removed corner in a diamond-shape within a range of 0.6 times to 1.0 times the smallest radius of curvature of the bent portion of the illuminant. Also, if all the corners are removed from the edges of the light guide plate so that they do not protrude, the directionality of the light guide plate disappears and the manufacturing process time for positioning the light guide plate is saved.

It is common to cover the illuminant with a reflector to increase the incident efficiency of the light from the illuminant to the light guide plate. When a bent illuminant such as the one described above is used, it is desirable for the reflector to include a straight first reflector and a second reflector positioned along two sides of the light guide plate such that at the edge the first reflector is covered by the second reflector. It is also possible for the reflector to include a first reflector that covers the lower half portion of the illuminant on one side of the light guide plate and a second reflector that covers the upper half of the illuminant from the other side of the light guide plate.

The diffusion pattern that diffuses light incident to the light guide plate from the bent illuminant can be generated by the following method. To generate a diffusion pattern that evenly radiates, from the other side of the light guide plate, light introduced from the illuminant to the light guide plate in an illumination device where a cylindrically-shaped illuminant is positioned near at least a first side and a second side of a substantially rectangular light guide plate, the density distribution per unit area of the diffusion pattern can be found by the following method: finding a predicted emitted light intensity distribution for the y-direction along the first side based on the intensity of the light incident to the light guide plate from the second side and the density distribution of a presupposed diffusion pattern; then finding a predicted emitted light intensity distribution for the x-direction along the second side based on the intensity of

the light incident to the light guide plate from the first side and the density distribution of the presupposed diffusion pattern; and then compensating the density distribution of the presupposed diffusion pattern so that the sum of the predicted emitted light intensity distribution for the x-direction and the predicted emitted light intensity distribution for the y-direction on arbitrary rectangular xy coordinates of the light guide plate fit within a fixed range.

When an edge reflector is installed at at least one of the two sides opposite to the first side and the second side, respectively, for reflecting the light from the inner part of the light guide plate to the light guide plate, it is desirable to compensate the density distribution by computing the reflected light intensity incident from the edge reflector to the light guide plate with a fixed attenuation factor; finding a predicted emitted light intensity distribution for at least one of the x and y directions of the reflected light intensity; and adding this to the predicted emitted light intensity distribution found above.

By printing the diffusion pattern described above on the light guide plate or by putting on the light guide plate a sheet with the pattern formed on it, light introduced from the bent illuminant can be evenly radiated from the light guide plate. Similarly, light can be evenly emitted by making the thickness of a light guide plate with an even diffusion pattern inversely proportion to the compensated density distribution of the diffusion pattern.

Effects of the heat from the illuminant can be minimized by using as a bent illuminant an L-shaped illuminant and by placing in a position opposite to the illuminant a driver device such as a driver IC for driving the liquid crystal display. Consequently, as the threshold value of the driver does not become unstable due to the heat, a color display with stable contrast is obtained. Further, a high quality display with high brightness and a small illumination device are also obtained.

Further, a stable, high quality display can be obtained that reduces heat using an even longer U-shaped illuminant. The brightness of the display is easy to adjust when illuminants such as L-shaped and U-shaped illuminants are used because nearly the same intensity of light is incident from the periphery of the light guide plate. Of course, an O-shaped illuminant can also be arranged around the periphery of a rectangular light guide plate as well as an illuminant bent to fit the shape of any other polygon.

Other objects and attainments together with a fuller understanding of the invention will become apparent and appreciated by referring to the following description and claims taken in conjunction with the accompanying drawings.

BRIEF DESCRIPTION OF THE DRAWINGS

FIG. 1 is a sketch of a liquid crystal display using the surface-type illumination device in accordance with the first embodiment of the invention.

FIG. 2 is a cross-sectional view of FIG. 1 showing the structure of the liquid crystal display.

FIG. 3 is a break-down view showing the structure of the liquid crystal display shown in FIG. 1.

FIG. 4 is a break-down view showing the construction of the surface-type illumination device used in the liquid crystal display shown in FIG. 1.

FIG. 5 is a top plan view illustrating the combination of the surface-type illumination device shown in FIG. 4 and the liquid crystal display panel.

FIG. 6 is an explanatory drawing showing the positioning of the light guide plate and fluorescent light of the surface-type illumination device of FIG. 4.

FIG. 7 is a cross-sectional view taken along the line VII—VII in FIG. 5 showing the relationship of the light guide plate, fluorescent light, and reflector of the surface-type illumination device of FIG. 4.

FIGS. 8A and 8B illustrate the assembly of the reflector of FIG. 7.

FIG. 9 is an enlarged view of the edge of the light guide plate.

FIGS. 10A–10D show enlarged views of several possible edge formations of the light guide plate.

FIG. 11 is an explanatory drawing showing the diffusion pattern formed on the diffusion sheet which sticks to the light guide plate.

FIG. 12A is a plan view showing a light guide plate whose thickness has been changed.

FIG. 12B is a cross-sectional view showing a light guide plate whose thickness has been changed.

FIG. 13 is a top plan view showing the combination of the liquid crystal display panel and illumination device in accordance with the second embodiment of this invention.

FIG. 14 is a cross-sectional view showing the relationship of the liquid crystal display panel, illumination device, and illuminant as shown in FIG. 13.

FIG. 15 is a break-down view showing the construction of the structure of the surface-type illumination device used in the liquid crystal display shown in FIG. 14.

FIG. 16 is an explanatory drawing showing the relationship of the light guide plate and the fluorescent light which is in the surface-type illumination device of FIG. 15.

FIG. 17 is an explanatory drawing showing the diffusion pattern that is printed on the light guide plate of FIG. 15.

FIG. 18 is a graph showing the surface temperature of the liquid crystal display panel shown in FIG. 13.

FIG. 19 is an explanatory drawing showing another relationship of the light guide plate and the fluorescent light.

FIG. 20 is an explanatory drawing showing still another relationship of the light guide plate and the fluorescent light.

FIG. 21 is an explanatory drawing showing a conventional light guide plate and fluorescent light.

FIG. 22 is a graph showing the surface temperature of a liquid crystal display panel using a surface-type illumination device similar to the one shown in FIG. 21.

DESCRIPTION OF THE PREFERRED EMBODIMENTS

EMBODIMENT 1

FIG. 1 is a sketch of liquid crystal display 1 in accordance with one embodiment of this invention. Liquid crystal display 1 is constructed with liquid crystal display panel 10 and an illumination device to be described later sandwiched between upper case 2 and lower case 3. Upper case 2 and lower case 3 are fixed in place by tooth 4. The scanning data that comprises the image is supplied from the host side to each row or column through tape electrode 5 and tape electrode 6. This data is latched by a driver IC which will be described below, is synchronized, and is supplied to liquid crystal display panel 10 where the image is formed. Power is supplied from the driver circuit of the host side to the fluorescent light comprising the illumination device through connector 7, connector 7 extending past liquid crystal display 1 and used for initiating lighting.

The basic structure of one embodiment of liquid crystal display 1 will be explained using the cross-sectional view of liquid crystal display 1 shown in FIG. 2 and the break-down view of liquid crystal display 1 shown in FIG. 3. In liquid crystal display 1, illumination device 20 is installed in lower case 3. Above device 20, liquid crystal display panel 10 is installed using frames 30 and 31. Liquid crystal display panel 10 is formed by enclosing the liquid crystal, transparent electrodes, etc. between two layers of transparent glass substrates 11 and 12. At side 10a of liquid crystal display panel 10, a plurality of driver ICs 13 are installed for latching pixel data for the rows and sending it to the liquid crystal display panel. Also, at side 10b, which is adjacent to side 10a, a plurality of driver ICs 14 are installed for latching pixel data for the columns and sending it to the liquid crystal display panel.

Frames 30 and 31 are used to protect illumination device 20 and to position it within the case. At the same time, it also fills the role of maintaining a fixed distance for gap 33 between illumination device 20 and liquid crystal display panel 10, for example, 0.2–1 mm. For this reason, frames 30 and 31 are prepared so that their lower halves 34 and 35 support illumination device 20 and their upper halves 36 and 37 act as spacers between illumination device 20 and liquid crystal display panel 10. In this example the frame is divided into two pieces, however, the number of pieces is not limited to two. For example, three pieces, four pieces, or even more is possible, and even just one piece is also possible. Furthermore, the frame need not cover the entire periphery of illumination device 20 or liquid crystal display panel 10. A plurality of pieces may be arranged in appropriate places.

Illumination device 20 is a surface-type illumination device set up with a cylindrically-shaped fluorescent light 22 at the edge of substantially rectangular light guide plate 21. Fluorescent light 22 is roughly L-shaped and is covered by reflectors 23a and 23b. Wires for supplying power to drive fluorescent light 22 extend from both ends of fluorescent light 22 and are connected to the driver circuit on the host side through connector 7 which is for turning on the light. FIG. 4 is a break-down view of illumination device 20 and will be used to explain the structure of the illumination device of this embodiment. Illumination device 20 is comprised of light guide plate 21, which is substantially rectangular in shape and has the corner of at edge 40 missing, fluorescent light 22, which encompasses edge 40 in an L-shape, and reflectors 23a and 23b, which cover fluorescent light 22 in the direction of light guide plate 21 and efficiently reflect light from fluorescent light 22 to light guide plate 21. On lower surface 21b of light guide plate 21, i.e., the side opposite to the side where liquid crystal display panel 10 is arranged, pattern sheet 24, which is printed with diffusion pattern 50, and reflecting sheet 25 are arranged in that order. On upper surface 21a of light guide plate 21, i.e., the side where liquid crystal display panel 10 is arranged, diffusion sheet 26 and prism sheet 27 are arranged. Edge reflective tape 28 is put on edge 41a and 41b, opposite to fluorescent light 22 of light guide plate 21.

Light guide plate 21 is a transparent material whose index of refraction is greater than that of air. An index of refraction equal to or greater than 1.41 is desirable using such materials as acrylic resin, polycarbonate resin, amorphous polyolefine-type resin, and polystyrene resin. Use of these types of materials for light guide plate 21 results in a critical angle of 45° or less. If upper surface 21a and lower surface 21b are smooth and mirror-like, the light incident from edges 41a, 41b, 41c, and 41d, which are formed at right angles to surface 21a and 21b, is completely reflected from surfaces 21a and 21b.

Pattern sheet 24 is a transparent sheet with a fixed number of diffusion patterns 50 printed on it, the printed diffusion patterns being adhered to lower surface 21b of light guide plate 21. Light incident from sides 41, to some extent, reaches diffusion pattern 50 and, without being completely reflected, will be diffused in the direction of upper surface 21a. Consequently, light incident from the fluorescent light by way of the edges is emitted to liquid crystal display panel 10 from upper surface 21a.

Reflecting sheet 25 is a thin PET sheet with a thickness of approximately 0.05–0.5 mm. Light coming from upper surface 21a of light guide plate 21 through diffusion pattern 50 travels through diffusion sheet 26 and prism sheet 27, which are arranged on the upper portion of upper surface 21a and light up liquid crystal display panel 10. However, a portion of the light is reflected from sheets 26 and 27 in the lower direction. The light reflected from the upper direction is returned to light guide plate 21, among others, through reflecting sheet 25 among others. Reflecting sheet 25 may be aluminum or other non-PET material. Also, lower case 3 may be used as a reflector in place of a reflecting sheet. Further, the frame of a computer or similar part carrying the illumination device or liquid crystal display can also be used as a reflector in place of the reflecting sheet.

Diffusion sheet 26 is an approximately 0.05–0.5 mm thin PET sheet or PC sheet. Diffusion sheet 26 diffuses the light that is reflected by diffusion pattern 50 and radiated from upper surface 21a. Diffusion pattern 50 is often formed in a narrow line configuration or net configuration. The light that is reflected by these types of patterns is diffused by diffusion sheet 26. The diffusion pattern cannot be recognized from liquid crystal display panel 10. Diffusion sheet 26 is arranged with a very small layer of air between it and upper surface 21a of light guide plate 21. The angle mentioned above is maintained in regards to the angle of upper surface 21a. Reflection sheet 26 is not limited to a PET sheet and such sheets as acrylic-type sheets, among others, may be used.

Prism sheet 27, which is arranged on diffusion sheet 26, is made up of very small linear prisms lined in a cross-sectional array. The angle of the light radiating from diffusion sheet 26 is arranged to improve the illuminating intensity of liquid crystal display panel 10. Although the brightness can be improved through prism sheet 27, when sufficient brightness is achieved through diffusion sheet 26, prism sheet 27 can be omitted, thus reducing manufacturing cost.

Fluorescent light 22, which is used as the light source of illumination device 20, is in an L-shape, and is positioned adjacent to edges 41c and 41d of light guide plate 21. It is desirable, as will be explained later, to maintain a gap between edges 41c and 41d and fluorescent light 22 of around 0.8–1.5 mm. The corner of edge 40 of light guide plate 21 is removed and fluorescent light 22 is able to be positioned with the above noted gap. Also, by removing this corner, fluorescent light 22 and the corner of light guide plate 21 are prevented from touching and damage to the fluorescent light can be prevented.

Fluorescent light 22 is covered by reflectors 23a and 23b to make the light discharged from fluorescent light 22 incident with good efficiency from edge 40 of light guide plate 21. Reflectors 23a and 23b are PET sheets deposited with silver and of a thickness of approximately 0.01–0.1 mm. In order to provide low cost reflectors that cover the L-shaped fluorescent light and that are easy to install, two straight reflectors are used. This will be explained in greater detail below.

Edge reflective tape 28 is arranged at two edges 41a and 41b, which are opposite to edges 41c and 41d, respectively, where fluorescent light 22 and reflector 23 are installed. Edge reflective tape 28 is a PET sheet deposited with silver with thickness of approximately 0.01–0.1 mm. The light introduced to light guide plate 21 from fluorescent light 22 is completely reflected away. The light that reaches the edges of the opposite side is returned to light guide plate 21. Materials such as white PET sheets and aluminum can be used for the edge reflective tape as well as the reflectors mentioned above. It is also possible to integrate these into a case or frame.

FIG. 5 shows liquid crystal display panel 10 installed on illumination device 20. Driver ICs 13 and 14 are arranged on sides 10a and 10b, respectively, adjacent to liquid crystal display panel 10. Opposite to sides 10a and 10b, L-shaped fluorescent light 22 extends along two sides 20c and 20d of illumination device 20. Because of this arrangement, driver ICs 13 and 14 are not directly influenced by the heat from fluorescent light 22. Consequently, the temperature of the driver ICs does not rise significantly, preventing changes in the driver's threshold value. For this reason, an image with very low fluctuations in contrast can be obtained using liquid crystal display panel 10.

By using a light like the L-shaped fluorescent light 22 shown in FIG. 6, the temperature distribution of the entire liquid crystal display panel 10 becomes flat. In order to illuminate liquid crystal display panel 10 for color displays, high brightness is essential. Because of this, as explained earlier in connection with FIG. 22, the output of conventional fluorescent lights that are installed at one edge is increased and the slope of the temperature distribution of the liquid crystal display panel becomes large. This results in color and brightness irregularities and poor display quality. However, by introducing light from two edges, as in the instant invention, a rise in the temperature of the liquid crystal display panel can be suppressed and high brightness can be obtained.

When introducing light from two edges, it is possible to use two fluorescent lights. This makes it possible to limit the increase in the temperature of the liquid crystal display panel as compared to the method of introducing light from only one edge. However, as two driver circuits would be necessary to drive the two fluorescent lights, it would not be desirable to incorporate them into small personal computers and televisions. In the instant invention, temperature rise can be suppressed and a high brightness can be obtained without increasing the number of driver circuits.

Also, because the light conversion efficiency can be increased by using an L-shaped fluorescent light, temperature rise can be further limited. The majority of the power input into the fluorescent light is consumed as a cathode drop voltage which generates glow discharge. For example, when two fluorescent lights are used, two times the power is required, with most of it being consumed in order to generate two glow discharges. However, when a long fluorescent light is used, such as in the instant invention, the cathode drop voltage consumed by glow discharge does not increase that much. Because of this, when two times the power is supplied, most of the increased power is consumed as a positive column gradient voltage in generating light. Consequently, the same brightness can be obtained with lower voltage and lower temperature rise. For this reason, the rise of the temperature of the liquid crystal display panel can be held down and a good quality image can be obtained. Also, because the power consumption can be kept down, it is a suitable illumination device for illumination in liquid

crystal display panels in small, portable devices where batteries are used as the power source.

There are many merits in the illumination device of the instant invention which uses L-shaped fluorescent light 22. However, it is not as easy as just installing L-shaped fluorescent light 22 at edge 40 of light guide plate 21. This is because corner 43 of rectangular-shaped light guide plate 21 (when the corner has not been removed) and bent portion 22a of fluorescent light 22 interfere with each other and therefore, gap 42 between edge 41 and fluorescent light 22 becomes exceedingly large. When gap 42 cannot be reduced, the entire illumination device 20 becomes larger and the scale of the liquid crystal display cannot be reduced. Also, when the gap between edge 41 and fluorescent light 22 becomes larger, the light introduced to edge 41 decreases. Reflector 23 can, to some extent, prevent the decrease of the light from fluorescent light 22, but a large reflector is required. However, in light guide plate 21 of the instant invention, at edge 40, corner 43 which interferes with fluorescent light 22, is removed so that the corner does not stick out and gap 42 is reduced. By removing the corner at edge 40, damage to fluorescent light 22 due to corner 43 impacting fluorescent light 22 during shipping can be prevented. Also, damage to fluorescent light 22 caused by thermal expansion of light guide plate 21, vibration, etc. can be prevented.

Gap 42 between edge 41 and fluorescent light 22 is not completely eliminated. Not only do problems with precision during product manufacturing exist, but if gap 42 is reduced too much, the light reflected to reflector 23 is absorbed by fluorescent light 22 and the introduction efficiency to surface 41 is reduced. In FIG. 7, the light radiated from fluorescent light 22 to the opposite side at edge 40 is reflected by reflector 23 and introduced to edge 40. Consequently, if gap 42 is too small, the reflected light is introduced to fluorescent light 22 and completely absorbed within fluorescent light 22 and, thus, the amount of light introduced to edge 40 is reduced. If gap 42 is large, the incident efficiency improves, but when the width of gap 42 exceeds a prescribed value, the increase in the incident efficiency becomes less to the extent that limiting the size of illumination device 20 becomes more desirable. An appropriate gap 42 is judged by this inventor to be approximately 0.8–1.5 mm. More specifically, in the case of fluorescent light 22 with a diameter of 2.5–4 mm, a gap of around 1–1.5 mm is desirable.

The light reflected from reflector 23 is an important light source for illumination device 20. Although there are several different ways of setting up a reflector with respect to bent fluorescent light 22 of the instant invention, one method, as shown in FIG. 8, is to use two reflectors 23a and 23b which are made from flat material and bent in a nearly half circular shape. Reflector 23a corresponds to the short side of light guide plate 21 and is long enough to cover from bent portion 22a to electrode 22b of the short side of bent fluorescent light 22. Likewise, reflector 23b corresponds to the long side of light guide plate 21 and is long enough to cover from bent portion 22a to electrode 22c on the long side of bent fluorescent light 22. At the time of manufacturing illumination device 20, one of the reflectors, for example, the shorter reflector 23a is first arranged. If the other reflector, for example, longer reflector 23b, is laid from the top of the first reflector to the other side fluorescent light 22 can be completely covered. In this way, two separate reflectors 23a and 23b can be used to easily cover bent fluorescent light 22 and assembly of the reflectors is made easy. Also, in conforming to the bent-shape of fluorescent light 22, reflectors 23a and 23b do not have a complex shape, but rather, a simple

straight-line shape is used and therefore manufacturing cost can be kept down.

The aperture ratio is vital to increasing the incident efficiency from fluorescent light 22 to edge 40. A desirable range for this aperture ratio, which is defined as (thickness of light guide plate 21)/(diameter of fluorescent light 22), is around 0.9–2. If the aperture ratio is higher, the incident efficiency does not improve much.

The removal of different shapes of the corner at edge 40 is possible. In this embodiment of the invention, a corner in the shape of an isosceles triangle is removed from edge 40. Edge 43, which makes an angle of approximately 45° with respect to both edges 41c and 41d, is formed by edge 40. Because the light directly incident to edges 41c and 41d from fluorescent light 22 is reflected at edge 40, the influence of this portion to the intensity of the light radiated from upper surface 21a of light guide plate 21 is small. The influence of this removed shape to the uniformity of the brightness is also small. However, with the scattered light that differs in the incident angle, there is a possibility that the brightness uniformity incident from edge 43 and radiated from upper surface 21 will be hindered. In the instant invention, reflecting member 44 is mounted to prevent light incident to light guide plate 21 from edge 43. A plastic sheet deposited with white, silver, or aluminum among others or even a molded part can be used as reflecting member 44. This reflects light rays and prevents them from leaving light guide plate 21 and passing through edge 43, and at its opposite side, it shields light rays coming from fluorescent light 22, maintaining brightness uniformity. As edge 40 becomes larger, the light introduced from light guide plate 21 is reduced in the vicinity of the edge. Consequently, in order to maintain uniformity of brightness, it is desirable to establish limitations for the size of the triangle shape that will be removed. On one hand, if too little is removed, gap 42 between fluorescent light 22 and edge 41 cannot be properly maintained. In considering this, it is found desirable to make the length of the two substantially equal sides of the triangle to be within the range of 0.6 to 1.0 times the smallest radius of curvature of bent portion 22a of fluorescent light 22.

FIG. 10 shows other shape variations that are used in other embodiments of the invention. FIGS. 10A and 10B are examples of the corner removed from edge 40 which is parallel to adjacent sides 41c and 41d. In order to make this type of shape, edge 40 should be cut in a diamond shape, or in a square shape if the light guide plate is rectangular. Edges 45a and 45b, which are obtained after cutting a diamond-shaped corner, are approximately parallel to adjacent edges 41c and 41d of light guide plate 21. Consequently, the light introduced to light guide plate 21 from these edges 45a and 45b have substantially the same vector as edges 41c and 41d, and the probability of light being incident from the edges or being emitted from the edges is substantially the same. Therefore, it is rare for edge 40 to exert an influence on the uniformity of the brightness of the light radiated from the illumination device. For this reason, even if reflecting member 44 is omitted, it is still possible to obtain uniform brightness. However, it is difficult to maintain good uniformity if the gap between the edge and the fluorescent light becomes large. In considering the fluorescent light and interference, it is found to be desirable to make the length of one of the diamond-shaped sides, as noted above, to be within the range of 0.6 to 1.0 times the smallest radius of curvature of bent portion 22a of fluorescent light 22.

FIGS. 10C and 10D show other examples of the shape of edge 40 when the manufacturing process of light guide plate

21 is considered. In the case of injection formation of light guide plate 21 and from the aspect of type processing, a “fan-shape” as shown in FIG. 10C can be used. In the case of machining light guide plate 21 to form edge 40, an “opposite fan-shape” is possible. Of course, other shapes are also possible.

FIG. 11 shows diffusion pattern 50 for emitting light introduced to light guide plate 21 from bent fluorescent light 22 to the liquid crystal display panel through upper surface 21a of light guide plate 21. Although in this embodiment diffusion pattern 50 is printed on pattern sheet 42, it is also possible to print the pattern directly on lower surface 21b of light guide plate 21. It also is, of course, possible to draw diffusion pattern 50 on the lower surface of light guide plate 21 by using such methods as etching. Although line patterns and dot patterns are most commonly used, other patterns, as well as increasing or decreasing the pattern area density at different places are also possible.

In the case of the dot diffusion pattern, a method of increasing or decreasing the area of each dot or a method of increasing or decreasing the dot density is possible for adjusting the area density of the pattern. FIG. 11 shows an example of a pattern where the area of the dots are increased or decreased. The dot areas are small near edges 41c and 41d where fluorescent light 22 is positioned and these areas gradually increase as they move towards the opposing edges 41a and 41b. The dots near edge 40 which is near bent portion 22a of fluorescent light 22 have the smallest areas and the dots on the corner opposite to this between edge 41a and 41b have the largest areas.

The density distribution S(x,y) of this diffusion pattern is described below. Here, x and y are coordinates along edges 41c and 41d of fluorescent light 22, and a coordinate axis is used that increases in the direction away from fluorescent light 22. For some small areas, the density distribution of a diffusion pattern is assumed in advance to be S_{x_iy_j}. The intensity I_{1,1} of the light diffused by the diffusion pattern of density distribution S_{x₁y₁} as it relates to the light incident from the x direction with an intensity of L_x is represented by the following equation, where k is a reflection coefficient.

$$I_{1,1} = L_x \times S_{x_1 y_1} \times k \tag{1}$$

The intensity of the light diffused at the next small area in the x direction, I_{2,1}, is represented by the following equation.

$$I_{2,1} = (L_x - I_{1,1}) \times S_{x_2 y_1} \times k \tag{2}$$

Similarly, the intensity I_{1,j} of the light diffused by the diffusion pattern of density distribution S_{x_iy_j} and emitted by each small area as it relates to the light incident from the y direction with an intensity of L_y is represented by the following equation.

$$I_{1,j} = (L_y - \sum_{a=1}^{i-1} I_{a,j}) \times S_{x_i y_j} \times k + (L_x - \sum_{b=1}^{j-1} I_{i,b}) \times S_{x_i y_j} \times k \tag{3}$$

The average intensity radiated, I_{ave}, is represented by the following equation, where n is the number of the small areas in the x axis direction and m is the number of the small areas in the y axis direction.

$$I_{ave} = \sum_{i=1}^n \sum_{j=1}^m I_{i,j} / (n \times m) \tag{4}$$

Keeping the intensity of the light diffused by the diffusion pattern in a fixed range is necessary in order to make the

brightness of illumination device 20 uniform. Consequently, the density distribution S_{x_iy_j} of the diffusion pattern assumed in advance must be compensated and is represented by the following equation.

$$S^{1x_i y_j} = S_{x_i y_j} \times I_{ave} / \sum I_{i,j} \tag{5}$$

Just as above, the intensity of the light diffused at each small area using the compensated density distribution S^{1x_iy_j} of the diffusion pattern is recalculated. If this intensity can be kept within the permitted range, a diffusion pattern with proper brightness uniformity will be generated. If, despite using the once compensated density distribution S^{1x_iy_j}, the intensity of the light is not kept within the fixed range, repeat the compensation with the above technique.

In this way, when the diffusion pattern is generated, based on the intensity of the incident light in both the x and y directions, the intensity of the light emitted by diffusion at each coordinate, or each small area, is calculated for all directions. Along with finding the light intensity emitted at each small area that composes the intensity, the average light intensity is found and the density distribution of the diffusion pattern is compensated so that variations of the light intensity emitted from each small area will be kept within the average light intensity and fixed range.

Further, it is desirable to compensate for the intensity of the light reflected from edge reflective tape 28 which is placed on edges 41a and 41b. For the intensity of the light reflected from edge 41a and 41b by edge reflective tape, it is appropriate to add the intensity of the light that is diffused and emitted to the calculation of I_{i,j}, the intensity of light emitted from each small area.

The following is an equation for L_x, the intensity of light reflected from edge 41a in the x direction.

$$L_x' = (L_x - \sum_{i=1}^n I_{i,j}) \times \eta \tag{6}$$

In this equation, η is the reflection coefficient of the edge reflective tape. A number, for example, such as 0.5 may be used. Consequently, by performing a further calculation to that discussed above, a density distribution of the diffusion pattern compensated for the edge reflection can be obtained for the light source of the intensity incident from coordinate x_a in the x direction. And, by using diffusion pattern 50 which follows this density distribution, illumination with a high uniform brightness can be achieved through the light guide plate.

FIGS. 12A and 12B show an example of increasing and decreasing the thickness of the light guide plate instead of forming a diffusion pattern that differs in density on the light guide plate. In this example of light guide plate 29, diffusion pattern 51, which has a fixed density distribution, is printed on lower surface 29b. The cross section of light guide plate 29 is formed such that it is inversely proportional to the density distribution of the diffusion pattern discussed above. In other words, edges 41c and 41d of light guide plate 29 are thick and the thickness become gradually thinner in the direction of edges 41a and 41b. When the thickness of light guide plate 29 is thinned in inverse proportion to the density distribution of the diffusion pattern as above, the density of the light, which is illuminated by the diffusion pattern of uniform density formed on lower surface 29b, increases. Consequently, the intensity of the light diffused by diffusion pattern and emitted from upper surface 29a is averaged the same as the light emitted by the diffusion pattern with the density distribution as described above. A light guide plate such as light guide plate 29 shown in FIG. 12 can, therefore, also achieve illumination with high uniform brightness.

Illumination device 20, as explained above, uses as its light source one long fluorescent light that is bent in an L-shape and can be installed at the light guide plate which has a corner removed. Consequently, the effective overall length of the fluorescent light can be extended and the gross luminous energy increased without increasing the number of the driver circuits used for turning on the fluorescent light. Also, when there are a plurality of fluorescent lights, the necessity to adjust such things as the driver circuits so that the brightness of the plurality of fluorescent lights are in agreement does not exist. Further, because the light conversion efficiency can be increased, power consumption can be reduced. In regard to the output of the driver circuit for turning on the fluorescent light, although it is necessary to increase the output ability because the overall length of the fluorescent light is extended, when compared with the case of turning on two fluorescent lights, the output of the driver circuit is still low.

Illumination device 20 can be used in various ways as a surface-type illuminant in addition to the liquid crystal display discussed above. When used to provide backlight in a liquid crystal display panel, the fluorescent light can be arranged in a place opposite to the liquid crystal driver IC because an L-shape fluorescent light is used. For this reason, the effects of heat from the illuminant to the driver IC can be kept to a minimum and a stable display can be obtained. Also, as the illuminant and driver IC have no positional interferences, the size of the liquid crystal display can be reduced. Further, the power consumption of the illumination system is low, the heating power per unit length is low as the illuminating portion is long, and the temperature rise of the liquid crystal panel can, to a great extent, be kept down. Consequently, when high brightness necessary for color displays is shown, color and brightness irregularities of the liquid crystal panel can be prevented and a good quality, vivid color display can be obtained.

Further, to simplify the manufacturing process and obtain a display with uniform illumination and good display quality for the illumination device and the liquid crystal display, many things such as the shape of the reflector and the generation method of the diffusion pattern are improved and a low-cost liquid crystal display with good display quality is provided.

In the above, only one corner from edge 40 of the light guide plate is removed. However, it is also possible to remove all four corners. If all four corners of the same shape are removed, the directionality of the light guide plate becomes unimportant at the time of assembly and the manufacturing process can be further simplified.

EMBODIMENT 2

FIG. 13 shows a liquid crystal display using an illumination device 60, which differs from that described above, and liquid crystal panel 10 installed on illumination device 60. The drawings and descriptions which are substantially similar to the embodiment shown in FIG. 1 are eliminated. Also, the same reference numbers for liquid crystal display panel 10 and other parts that are in common with the first embodiment will be used and the descriptions will be eliminated.

Illumination device 60 uses a U-shaped fluorescent light 62 as a light source. Fluorescent light 62 is positioned next to edges 41a, 41c and 41d on light guide plate 61 of illumination device 60. Illumination device 60 is enclosed within frames 38 and 39, which are upper and lower sections, respectively. Upper frame 38 acts as a spacer to secure the gap between liquid crystal display panel 10 and illumination device 60.

The construction of illumination device 60 of this embodiment will be explained with reference to FIGS. 14 and 15. Within the U-shaped lower frame 39 of illumination device 60 are enclosed the following in the order from bottom to top, reflecting sheet 25, light guide plate 61, diffusion sheet 26, and prism sheet 27. U-shaped fluorescent light 62 is installed next to three of the edges of light guide plate 61, 41a, 41c, and 41d. The remaining edge 41b is attached with edge reflective tape 28. On top of lower frame 39, which encloses all of these, is the flat, U-shaped upper frame 38.

The mirror surface of the hyperbolic curve section of the inner surface 63 of lower frame 39 is formed by silver deposition or the like. The lower surface 64 of upper frame 38 is also silver deposited and mirrorized. The inner surface 63 and lower surface 64 of frames 39 and 38, respectively, function as a reflector. Thus, the reflector and frame described in the previous embodiment are integrated into one part. Consequently, the problems associated with assembling illumination device 60 is further reduced.

The explanation of the functions of reflection sheet 25, diffusion sheet 26, and prism 27 will be omitted as they are the same as that explained in the earlier embodiment. In this example, the pattern sheet is omitted because the diffusion sheet 52 is printed on lower surface 61b of light guide plate 61. The two corners are removed from edges 40a and 40b of light guide plate 61 in order to install U-shaped fluorescent light 62 with an appropriate gap 42 from the light guide plate, as explained in the embodiment above. FIG. 16 shows the relationship between fluorescent light 62 and light guide plate 61. The corner of edge 40b, which is between edges 41c and 41d, and the corner of edge 40a, which is between edges 41a and 41d, are removed so that they do not stick out. In this way, fluorescent light 62 can be installed with fixed gap 42 from edges 41, and the incident efficiency towards light guide plate 61 can be maintained at a high level. Also, damage to fluorescent light 62 caused by thermal expansion, shock etc. can be prevented. The shape of the removed corner, in this example, is a triangle with two sides of approximately equal length. However, as explained earlier, it is also possible to use other shapes.

FIG. 17 shows diffusion pattern 52, which is printed on lower side 61b of light guide plate 61. Diffusion pattern 52 is formed using the density distribution obtained by the generation method discussed above. In this embodiment, because in addition to the light source from edge 41c there is a light source from edge 41a, the area density of the diffusion pattern on this side is low and the area density of the diffusion pattern in the middle of lower surface 61b is high. Also, the area density of the diffusion pattern along edge 41d is low, and the area density of the diffusion pattern opposite to this side near edge 41b is high. Through diffusion pattern 52, the light introduced to light guide plate 61 is diffused and a uniform light is emitted from upper surface 61a of light guide plate 61 towards the liquid crystal display panel.

FIG. 18 shows the temperature distribution on liquid crystal display panel 10 of this embodiment. From this graph it can be seen that the temperature rise of that portion of the panel directly opposite to the fluorescent light increases only about 10 degrees above the regular temperature. As shown in FIG. 22, this is a significant reduction as compared with the temperature rise in a conventional illumination device. Because of the very small difference between the temperature of the central portion of the liquid crystal display panel and the temperature of the edge portions near the light source and the resulting flat temperature distribution, there

is a very small amount of image and brightness irregularities that appear on the liquid crystal display panel. Consequently, a good quality image can be obtained. Therefore, illumination device 60 is an illumination device that can irradiate a light of high brightness for color displays and can prevent a temperature rise on the liquid crystal display panel. Because of the use of a long light source bent in a U-shape, the amount of heating per unit length can be reduced and, still further, a reduction in power consumption can be achieved.

In the present embodiment of the liquid crystal display device, as shown in FIG. 13, driver IC 13 is arranged on one of the sides of the U-shaped fluorescent light. However, because the rise in temperature of fluorescent light 62 is small, thermal expansion towards driver IC is small and problems such as fluctuations in the threshold value can be controlled. Consequently, by using the liquid crystal display of this embodiment, a vivid and stable color image with high brightness can be obtained and low power consumption can be achieved. As only one driver circuit is necessary to turn on the fluorescent light, devices that use liquid crystal displays, such as televisions and personal computers, can be miniaturized. Because the discharge length is increased, the driver circuit output must be improved to turn on the U-shaped fluorescent light. However, as compared to turning on three separate fluorescent lights, the increase in the output of the driver circuit is small.

FIG. 19 shows an example of two approximately L-shaped fluorescent lights 72a and 72b installed on light guide plate 71. FIG. 20 shows three approximately L-shaped fluorescent lights 82a, 82b, and 82c installed on hexagonal light guide plate 81. The corners are removed from the edge portions 40 of both light guide plates 71 and 81 so that there is no interference with fluorescent lights 72 and 82 and these lights can be properly positioned. Structures discussed in the above embodiments, such as those of the reflectors, can also be used here.

Various shapes of surface-type illumination systems can be formed using a bent, cylindrical illuminant. With these illumination devices, a uniform illumination device with high brightness can be obtained that has low power consumption. Also, a high quality color display can be obtained when a color liquid crystal display panel is used.

The surface-type illumination device of the invention is suitable for providing backlight in liquid crystal display devices that use a liquid crystal display panel or for using as other flat, surface-type illumination devices. Because liquid crystal display devices using this illumination device can display vivid color with low power consumption, it can be used as a display in notebook PCs and other information processing devices as well as in devices such as liquid crystal TVs, video cameras, and other image processing devices.

While the invention has been described in conjunction with several specific embodiments, it is evident to those skilled in the art that many further alternatives, modifications and variations will be apparent in light of the foregoing description. Thus, the invention described herein is intended to embrace all such alternatives, modifications, applications and variations as may fall within the spirit and scope of the appended claims.

What is claimed is:

1. An illumination device comprising:

a substantially transparent and polygon-shaped light guide plate comprising at least first and second side edges;

an elongated illuminant comprising an L-shaped section facing said at least first and second side edges of said light guide plate;

said light guide plate comprising a cutout portion at a corner between said first and second side edges so as not to interfere with a facing bend in said L-shaped section of said elongated illuminant;

said cutout portion comprising a first leg and a second leg, said first leg being substantially parallel to said second side edge, and said second leg being substantially parallel to said first side edge.

2. An illumination device according to claim 1 comprising a gap distance in a range of about 0.8 to 1.5 mm formed between at least one of said first and second side edges and said facing illuminant.

3. An illumination device according to claim 2 wherein said gap distance is in a range of about 1.0 to 1.5 mm.

4. An illumination device according to claim 1 wherein an aperture ratio, defined as a thickness of said light guide plate/a diameter of said illuminant, is in the range of about 0.9 to 2.0.

5. An illumination device according to claim 1 further comprising a reflecting member covering said cutout portion.

6. An illumination device according to claim 1 wherein the length of one of said first and second legs is approximately 0.6 times to 1.0 times the smallest radius of curvature of said facing bend in said L-shaped illuminant.

7. An illumination device according to claim 1 further comprising a reflector covering said illuminant except in regions of said illuminant facing said first and second side edges of said light guide plate, said reflector comprising a first reflector portion and a second reflector portion positioned along legs of said L-shaped section of said illuminant.

8. An illumination device according to claim 1 further comprising a reflector covering said illuminant except in regions of said illuminant facing said first and second side edges of said light guide plate, said reflector comprising a first portion covering a lower portion of said illuminant and a second portion covering an upper portion of said illuminant.

9. An illumination device according to claim 1 wherein said light guide has a thickness formed so that it is inversely proportional to a density distribution calculated by:

computing a first predicted emitted light intensity distribution for a first direction along said first side edge based on the intensity of the light incident on said light guide plate from said second side edge and the density distribution of a presupposed diffusion pattern;

computing a second predicted emitted light intensity distribution for a second direction along said second side edge based on the intensity of the light incident on said light guide plate from said first side and the density distribution of the presupposed diffusion pattern; and

computing the density distribution of said diffusion pattern by compensating the density distribution of the presupposed diffusion pattern so that the sum of said first predicted emitted light intensity distribution and said second predicted emitted light intensity distribution on arbitrary rectangular coordinates of said light guide plate fit within a fixed range.

10. An illumination device according to claim 9 further comprising an edge reflector disposed along at least one of

17

two side edges of said light guide plate opposite to said first side edge and said second side edge, said edge reflector reflecting the light emitted by said light guide plate back to said light guide plate; and the density distribution of said diffusion pattern is computed by:

5 computing an intensity of light reflected by said edge reflector and incident on said light guide plate with a fixed attenuation factor;

10 computing a predicted emitted light intensity distribution for at least one of the first and second directions for said reflected light intensity; and

15 adding the predicted emitted light intensity distribution to the sum of said first predicted emitted light intensity distribution and said second predicted emitted light intensity distribution which are on arbitrary rectangular coordinates of said light guide plate.

18

11. An illumination device according to claim 1 further comprising a liquid crystal display that is illuminated by light emitted from one side of said light guide plate by a diffusion pattern formed on the other side of said light guide plate; and

a driver that drives said liquid crystal display, said driver arranged along two side edges of said light guide plate opposing said first and second side edges of said light guide plate.

12. An illumination device according to claim 1 wherein said illuminant is substantially U-shaped and faces said first and second side edges and a third side edge of said light guide plate.

* * * * *

UNITED STATES PATENT AND TRADEMARK OFFICE
CERTIFICATE OF CORRECTION

PATENT NO. : 6,108,060
DATED : August 22, 2000
INVENTOR(S) : Tatsuaki Funamoto et al.

It is certified that error appears in the above-identified patent and that said Letters Patent is hereby corrected as shown below:

On the title page, item 30, Foreign Application Priority Data, please add --July 13, 1992 [JP] Japan 4-184976--.

Signed and Sealed this
Twenty-ninth Day of May, 2001

Attest:



NICHOLAS P. GODICI

Attesting Officer

Acting Director of the United States Patent and Trademark Office

1536 U.S. PTO
09/321687
05/28/99

349 065
Class
ISSUE CLASS

PATENT NUMBER
6108060
6108060

U.S. UTILITY PATENT APPLICATION

DWB O.I.P.E. PATENT DATE **AUG 22 2000**
SCANNED *A.G. @ Q.A. HQ*

SECTOR	CLASS	SUBCLASS	ART UNIT	EXAMINER
	349	65	2971	Mahrowski

FILED WITH: DISK (CRF) FICHE
(Attached in pocket on right inside flap)

PREPARED AND APPROVED FOR ISSUE

ISSUING CLASSIFICATION					
ORIGINAL		CROSS REFERENCE(S)			
CLASS	SUBCLASS	CLASS	SUBCLASS (ONE SUBCLASS PER BLOCK)		
349	065	362	026	027	031
INTERNATIONAL CLASSIFICATION					
G02F	1/1335				
G01D	11/28				
F21V	7/04				
<input type="checkbox"/> Continued on Issue Slip Inside File Jacket					

<input type="checkbox"/> TERMINAL DISCLAIMER	DRAWINGS			CLAIMS ALLOWED	
	Sheets Drwg. 12	Figs. Drwg. 27	Print Fig. 10B+ 15	Total Claims 12	Print Claim for O.G. 1
<input type="checkbox"/> a) The term of this patent subsequent to _____ (date) has been disclaimed.	<i>Walter Malmoirski</i> (Assistant Examiner) 9/15/99 (Date)			NOTICE OF ALLOWANCE MAILED 9-22-99	
<input type="checkbox"/> b) The term of this patent shall not extend beyond the expiration date of U.S. Patent. No. _____	<i>William L. Sikes</i> WILLIAM L. SIKES SUPERVISORY PATENT EXAMINER GROUP 2500 (Primary Examiner) _____ (Date)			ISSUE FEE Amount Due \$1210.00 Date Paid 12/27/99	
<input type="checkbox"/> c) The terminal _____ months of this patent have been disclaimed.	<i>C. McKinney</i> (Legal Instruments Examiner) 9/23/99 (Date)			ISSUE BATCH NUMBER BB4	

WARNING:
The information disclosed herein may be restricted. Unauthorized disclosure may be prohibited by the United States Code Title 35, Sections 122, 181 and 368. Possession outside the U.S. Patent & Trademark Office is restricted to authorized employees and contractors only.

Form PTO-436A
(Rev. 6/98)

(LABEL AREA)
ISSUE FEE IN FILE

PATENT APPLICATION



09321687

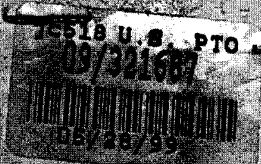

B

INITIALS M TV

CONTENTS

	Date received (Incl. C. of M.) or Date Mailed		Date received (Incl. C. of M.) or Date Mailed
1. Application papers		42.	
2. IDS	7-2-99	43.	
3. Priority Allowability	7-2-99	44.	
4. Priority Allowability	9-22-99	45.	
5. Amendment (312)	10-1-99	46.	
6. PTO 271	7-5-00	47.	
7. change of address	3/13/00	48.	
8. Final Drawings (Rights) set 1	5-28-00	49.	
9. Log - for Cafe	10/19/00	50.	
10.		51.	
11.		52.	
12.		53.	
13.		54.	
14.		55.	
15.		56.	
16.		57.	
17.		58.	
18.		59.	
19.		60.	
20.		61.	
21.		62.	
22.		63.	
23.		64.	
24.		65.	
25.		66.	
26.		67.	
27.		68.	
28.		69.	
29.		70.	
30.		71.	
31.		72.	
32.		73.	
33.		74.	
34.		75.	
35.		76.	
36.		77.	
37.		78.	
38.		79.	
39.		80.	
40.		81.	
41.		82.	

(LEFT OUTSIDE)



SEARCHED

Class	Sub.	Date	Exmr.
349	65, 70	9/14/99	wjm
362	26, 27, 31	9/14/99	wjm

SEARCH NOTES (INCLUDING SEARCH STRATEGY)

	Date	Exmr.

INTERFERENCE SEARCHED

Class	Sub.	Date	Exmr.
349	65, 70	9/15/99	wjm
362	26, 27, 31	9/15/99	wjm

(RIGHT OUTSIDE)

ISSUE SLIP STAPLE AREA (for additional cross references)

POSITION	INITIALS	ID NO.	DATE
FEE DETERMINATION	TCD		6/10/99
O.I.P.E. CLASSIFIER	MTW	5a	6-15-99
FORMALITY REVIEW	RNO	71477	6/28/99

INDEX OF CLAIMS

- ✓ Rejected
- Allowed
- (Through numeral) Canceled
- ⊕ Restricted
- N Non-elected
- I Interference
- A Appeal
- O Objected

Claim	Date
Final	
Original	
1	9-15-99
2	
3	
4	
5	
6	
7	
8	
9	
10	
11	
12	
13	
14	
15	
16	
17	
18	
19	
20	
21	
22	
23	
24	
25	
26	
27	
28	
29	
30	
31	
32	
33	
34	
35	
36	
37	
38	
39	
40	
41	
42	
43	
44	
45	
46	
47	
48	
49	
50	

Claim	Date
Final	
Original	
51	
52	
53	
54	
55	
56	
57	
58	
59	
60	
61	
62	
63	
64	
65	
66	
67	
68	
69	
70	
71	
72	
73	
74	
75	
76	
77	
78	
79	
80	
81	
82	
83	
84	
85	
86	
87	
88	
89	
90	
91	
92	
93	
94	
95	
96	
97	
98	
99	
100	

Claim	Date
Final	
Original	
101	
102	
103	
104	
105	
106	
107	
108	
109	
110	
111	
112	
113	
114	
115	
116	
117	
118	
119	
120	
121	
122	
123	
124	
125	
126	
127	
128	
129	
130	
131	
132	
133	
134	
135	
136	
137	
138	
139	
140	
141	
142	
143	
144	
145	
146	
147	
148	
149	
150	

If more than 150 claims or 10 actions
staple additional sheet here

(LEFT INSIDE)



US006108060A

United States Patent [19]

[11] Patent Number: **6,108,060**

Funamoto et al.

[45] Date of Patent: **Aug. 22, 2000**

[54] SURFACE-TYPE ILLUMINATION DEVICE AND LIQUID CRYSTAL DISPLAY

[75] Inventors: **Tatsuaki Funamoto; Toru Yagasaki; Fumiaki Akahane**, all of Suwa, Japan

[73] Assignee: **Seiko Epson Corporation**, Tokyo, Japan

5,057,974	10/1991	Mizobe	362/26
5,124,890	6/1992	Choi et al.	362/27
5,130,898	7/1992	Akahane	362/31
5,134,549	7/1992	Yokoyama	362/31
5,283,673	2/1994	Murase et al.	362/31
5,363,294	11/1994	Yamamoto et al.	362/26
5,764,493	6/1998	Liao	362/31
5,949,505	9/1999	Funamoto et al.	349/65

[21] Appl. No.: **09/321,687**

[22] Filed: **May 28, 1999**

0 317 250	5/1989	European Pat. Off.
0 442 529	8/1991	European Pat. Off.
0 561 329	9/1993	European Pat. Off.

Related U.S. Application Data

[62] Division of application No. 08/689,424, Aug. 9, 1996, Pat. No. 5,949,505, which is a division of application No. 08/204,374, May 10, 1994, Pat. No. 5,619,351.

[30] Foreign Application Priority Data

May 13, 1993 [JP] Japan 5-111852

[51] Int. Cl.⁷ **G02F 1/1335**; G01D 11/28; F21V 7/04

[52] U.S. Cl. **349/65**; 362/26; 362/27; 362/31

[58] Field of Search 349/65, 70; 362/26, 362/27, 31

[56] References Cited

U.S. PATENT DOCUMENTS

3,892,959	7/1975	Pulles	362/31
3,968,584	7/1976	Kingston	362/31
4,568,179	2/1986	Durbin et al.	362/343
4,630,895	12/1986	Abdala, Jr. et al.	362/31
4,648,690	3/1987	Ohe	362/31
4,729,067	3/1988	Ohe	362/26
4,729,068	3/1988	Ohe	362/31
4,811,507	3/1989	Blanchet	362/31
4,842,378	6/1989	Flasck et al.	362/31
4,860,171	8/1989	Kojima	362/31
4,933,814	6/1990	Sanai	362/26
4,974,122	11/1990	Shaw	362/31
4,985,809	1/1991	Mitsui et al.	362/31

FOREIGN PATENT DOCUMENTS

(List continued on next page.)

OTHER PUBLICATIONS

"Advancements In Backlighting Technologies For LCDs", K. Hathaway, SPIE Proceedings, High-Resolution Displays and Projection Systems, vol. 1664, Feb. 1992, pp. 108-116. Electronic Design, Aug. 2, 1961, p. 47. Voltarc Technical Bulletin "Fluorescent Lamp", 1987.

Primary Examiner—William L. Sikes
Assistant Examiner—Walter Malinowski
Attorney, Agent, or Firm—Mark P. Watson

[57] ABSTRACT

A surface-type illumination device suitable for providing backlight in a liquid crystal display is disclosed. For example, an L-shaped fluorescent light can be used as an illuminant and mounted next to two edges of a substantially rectangular light guide plate. The corner of an edge portion between the two edges is removed. The fluorescent light, the length of whose illuminating portion is long, is positioned with an appropriate gap from the light guide plate allowing for illumination with high brightness and low power consumption. Consequently, when the illumination device is used in a color liquid crystal display, appropriate backlight with high brightness can be obtained. Moreover, because the influence of the temperature from the illumination device is small, a stable color display can be achieved.

12 Claims, 12 Drawing Sheets

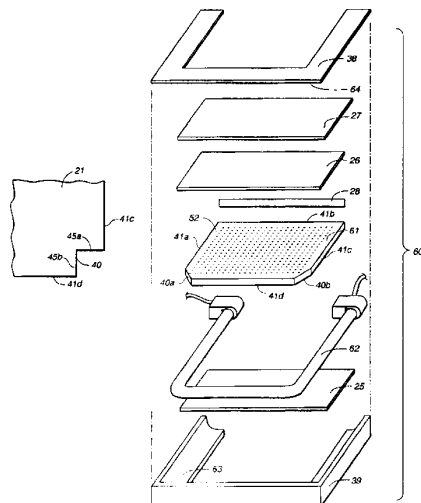

6,108,060

Page 2

FOREIGN PATENT DOCUMENTS

0 587 766	4/1925	France .	63-45537	3/1988	Japan .
0 145 934	10/1957	France .	63-175301	7/1988	Japan .
0 327 493	5/1958	France .	63-124217	8/1988	Japan .
2 620 795	3/1989	France .	64-45002	2/1989	Japan .
2 632 432	12/1989	France .	64-45003	2/1989	Japan .
54-40086	3/1979	Japan .	1-183626	7/1989	Japan .
60-205576	10/1985	Japan .	3-15476	5/1991	Japan .
61-166585	7/1986	Japan .	3-201304	9/1991	Japan .
61-248079	11/1986	Japan .	4-102888	4/1992	Japan .
62-102226	5/1987	Japan .	0 664 193	1/1952	United Kingdom .
63-062105	3/1988	Japan .	WO88/08149	10/1988	WIPO .

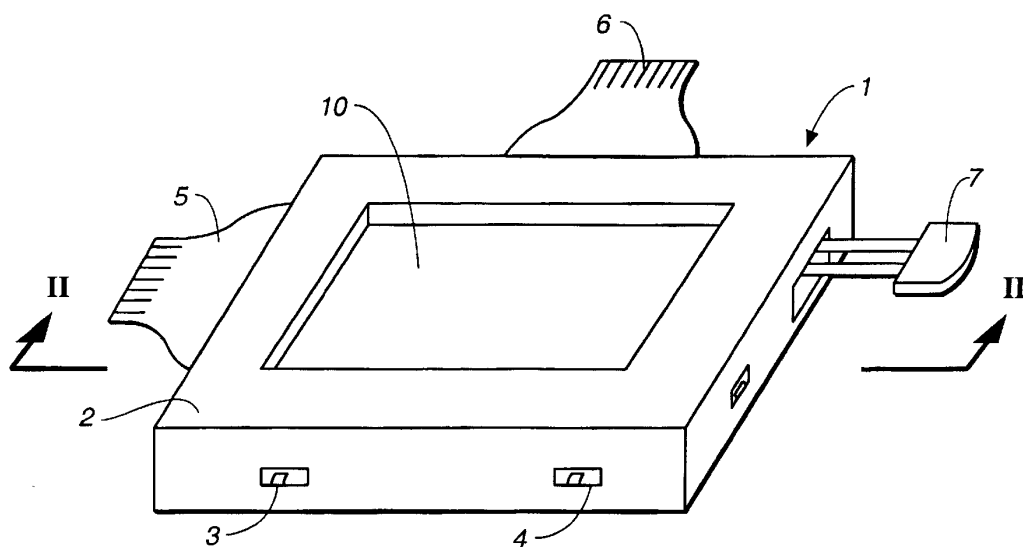

FIG._1

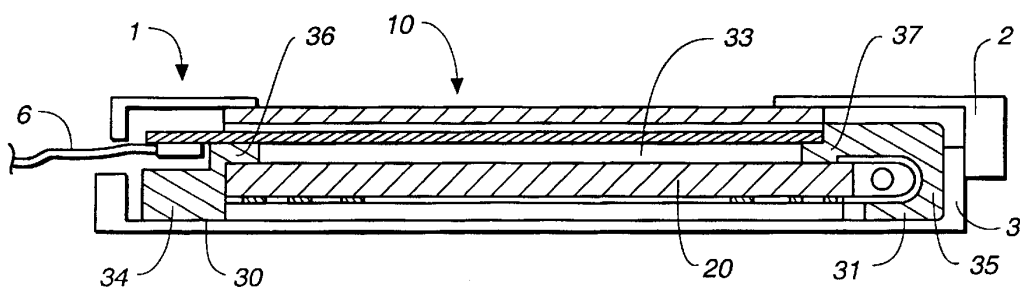

FIG._2

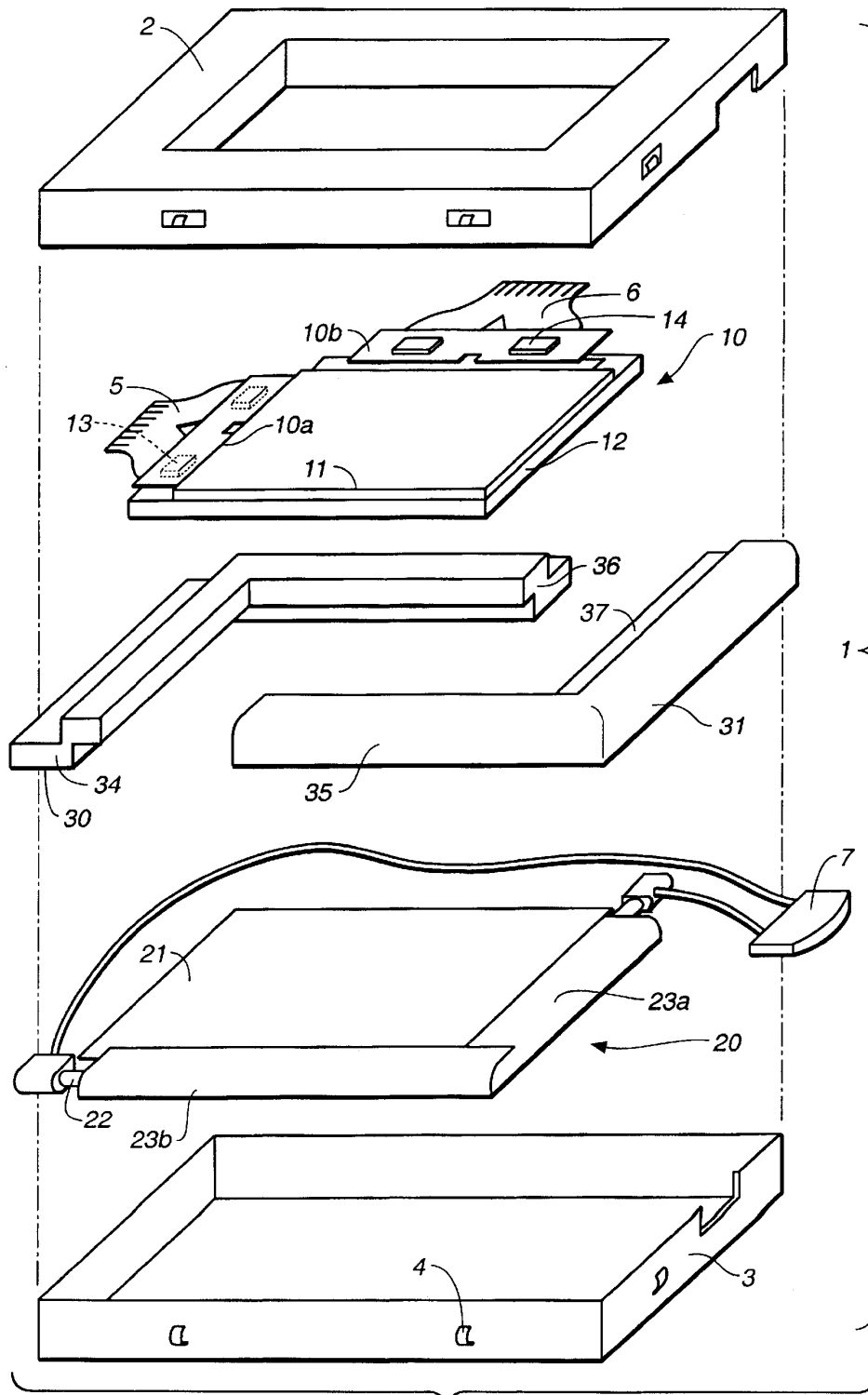

FIG. 3

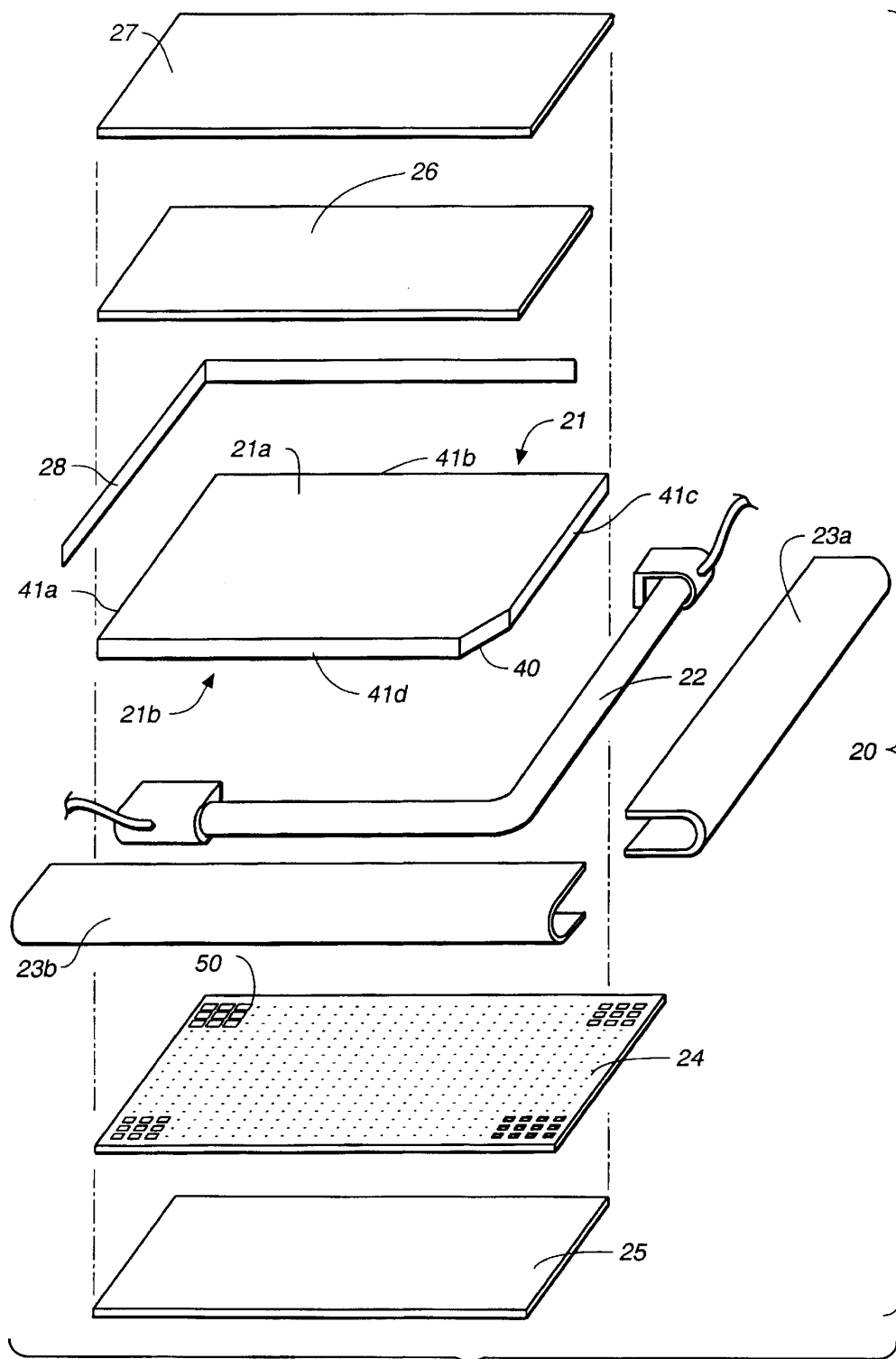

FIG. 4

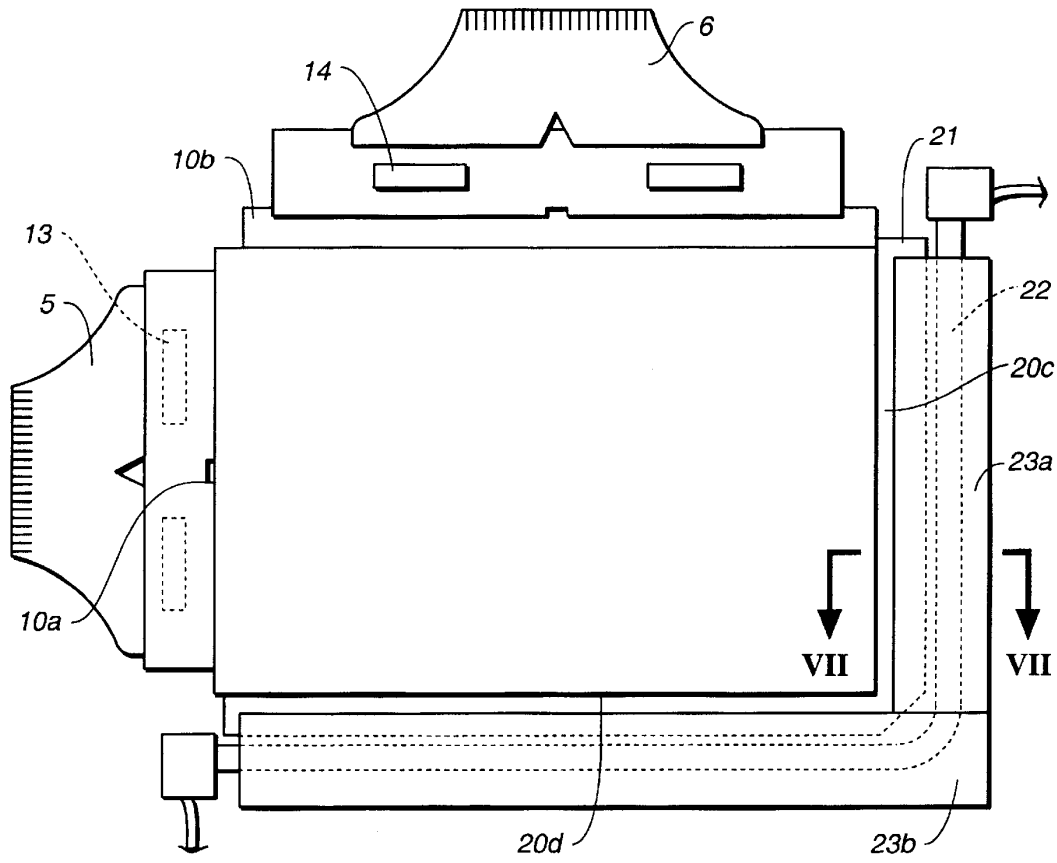

FIG._5

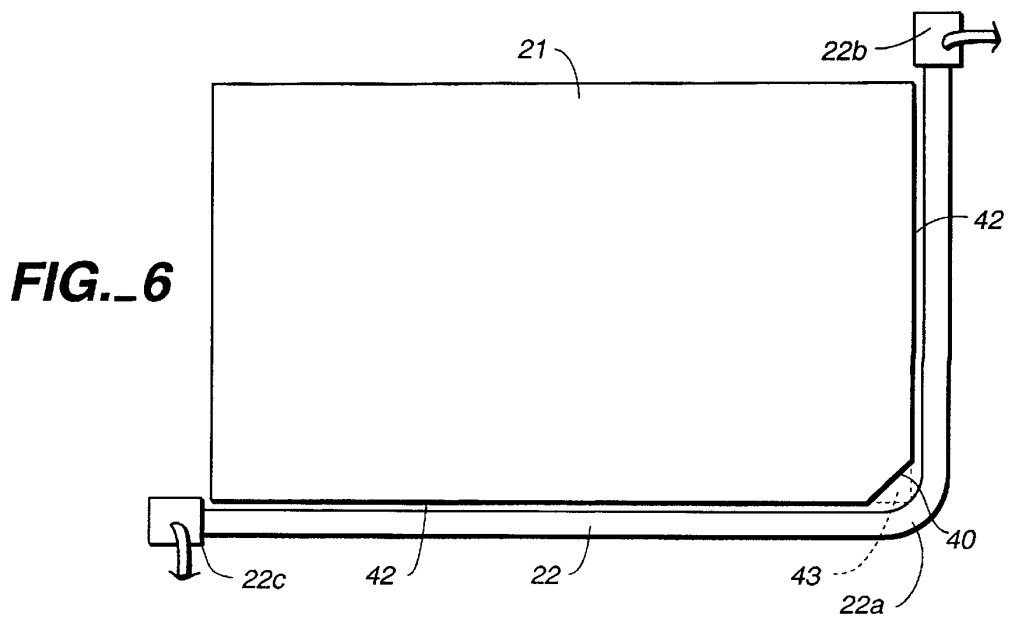

FIG._6

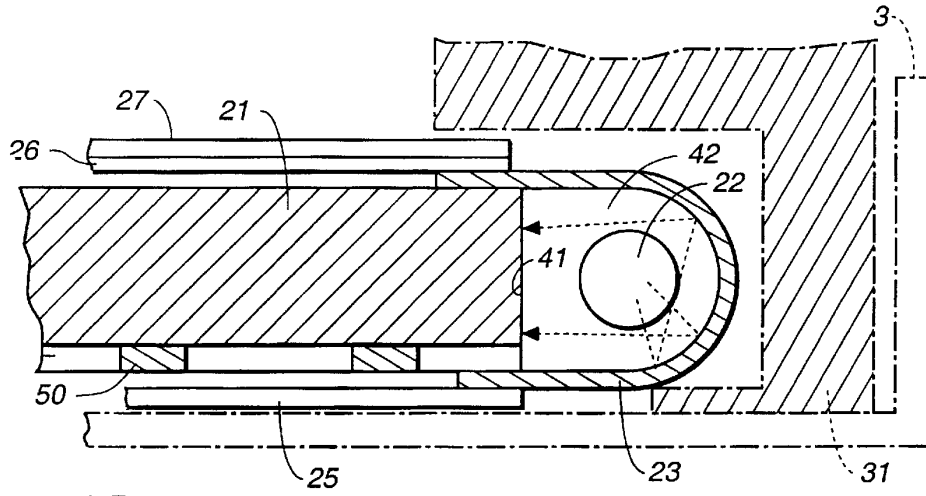

FIG._7

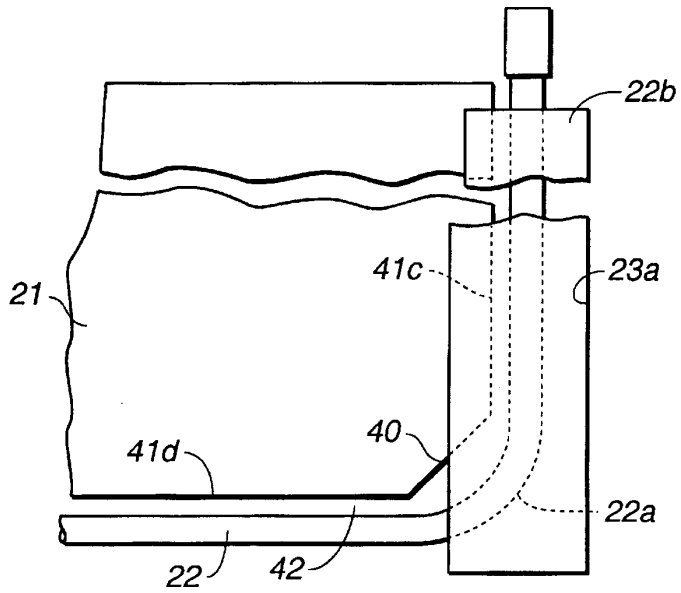

FIG._8A

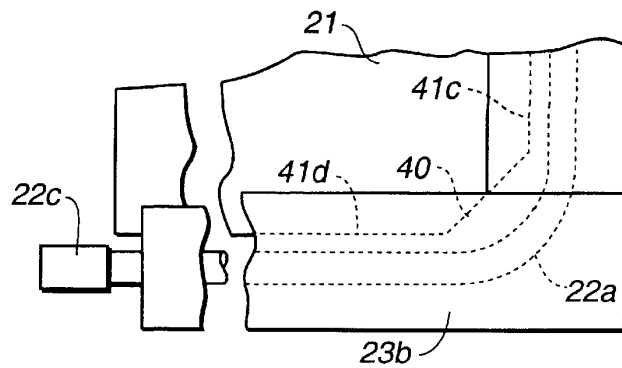

FIG._8B

FIG._9

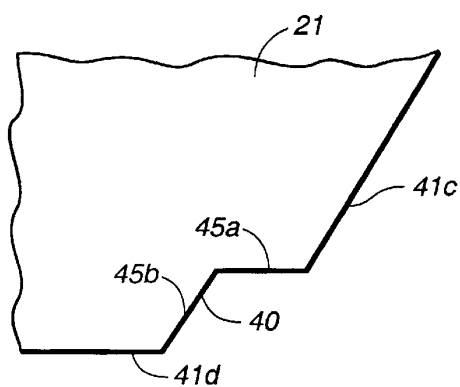
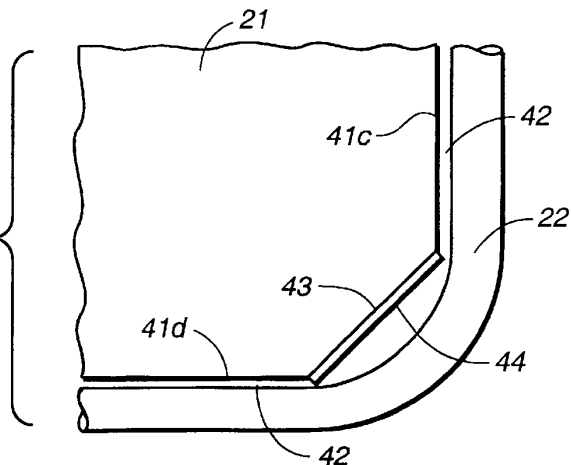

FIG._10A

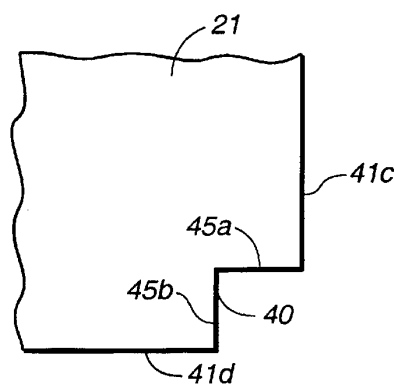

FIG._10B

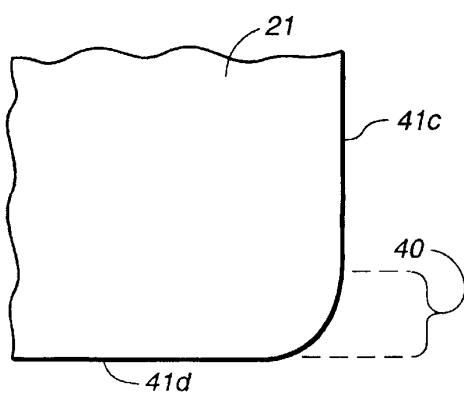

FIG._10C

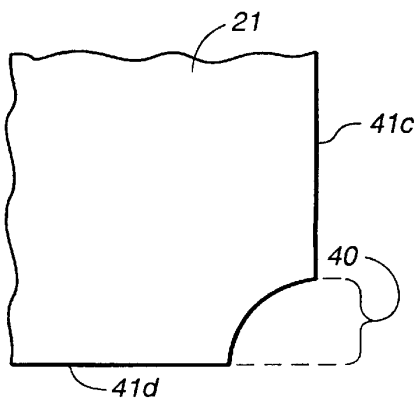

FIG._10D

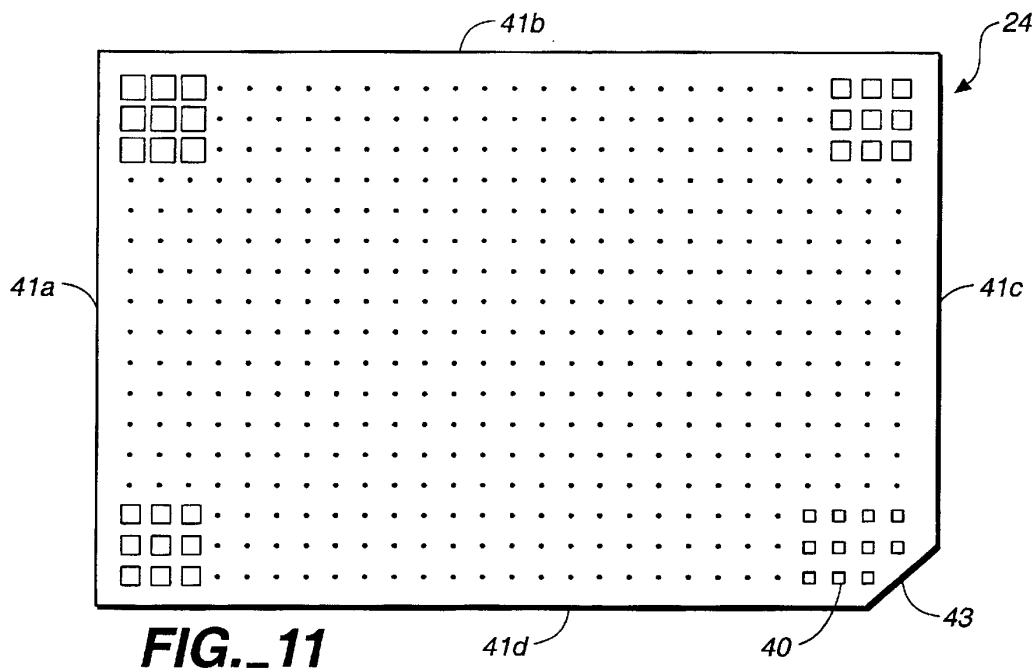

FIG. 11

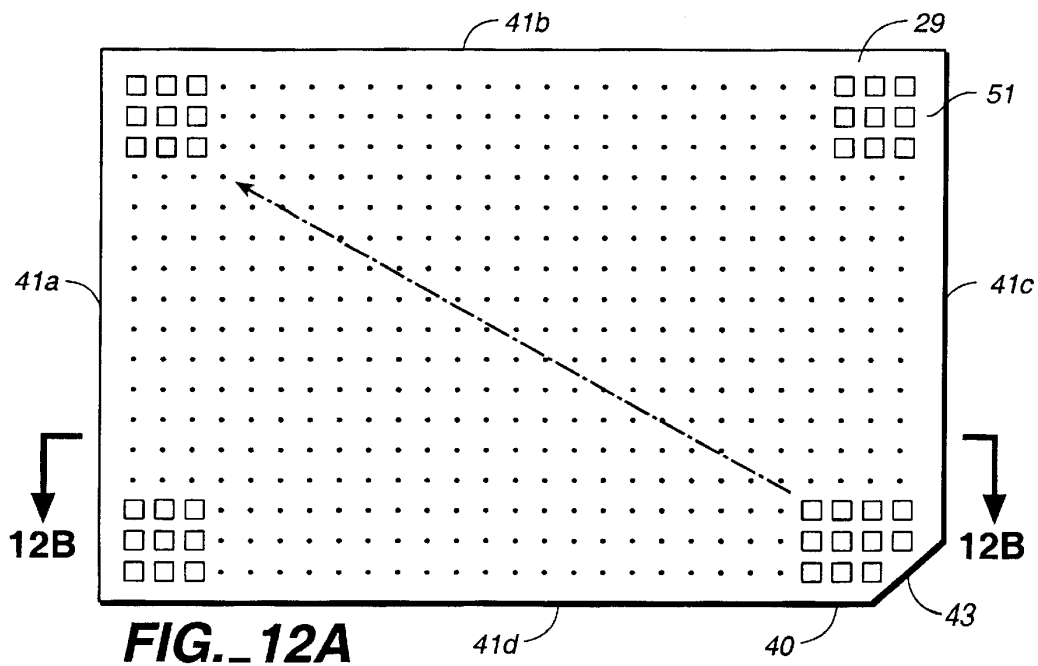

FIG. 12A

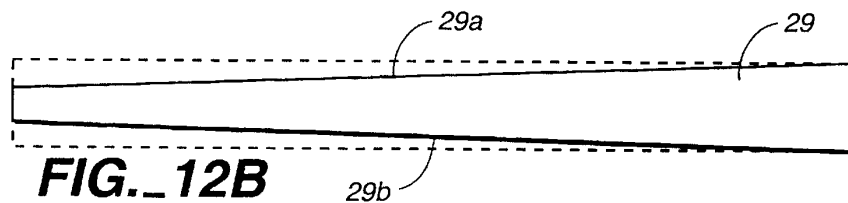

FIG. 12B

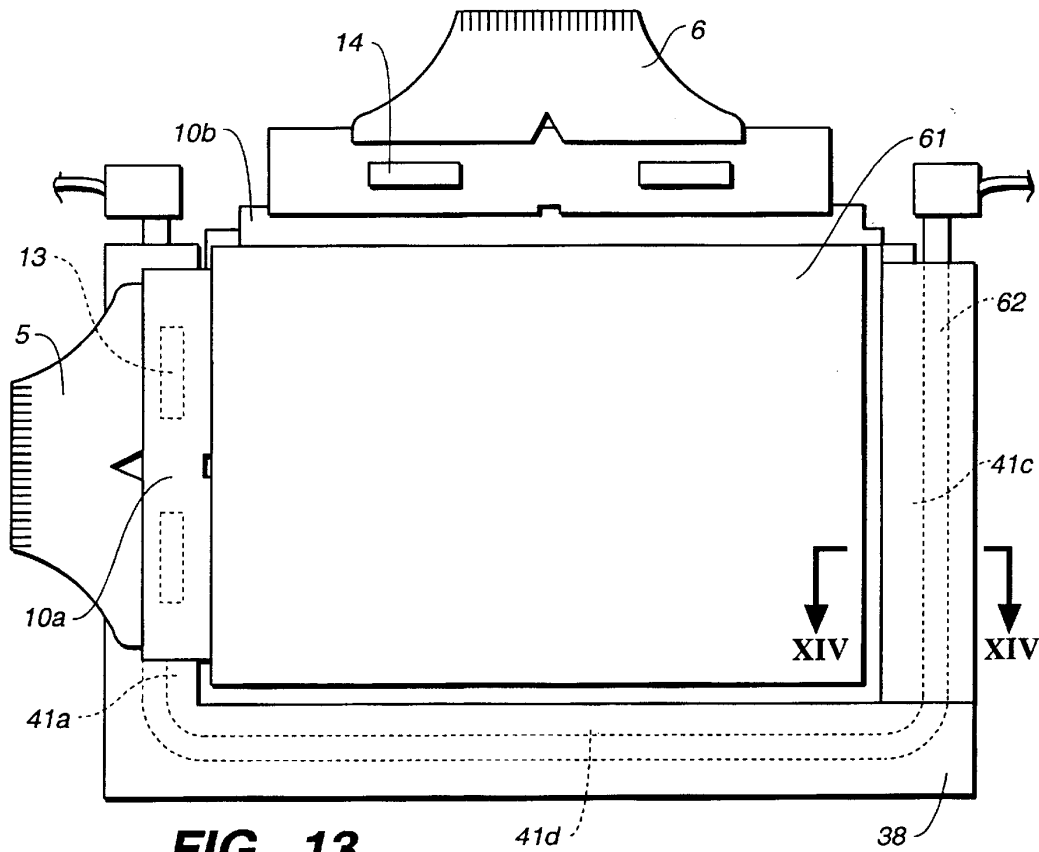

FIG. 13

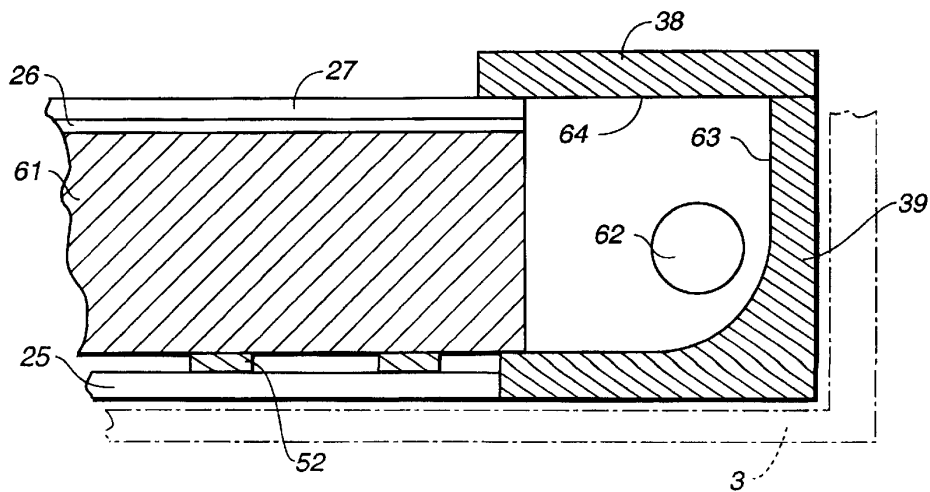

FIG. 14

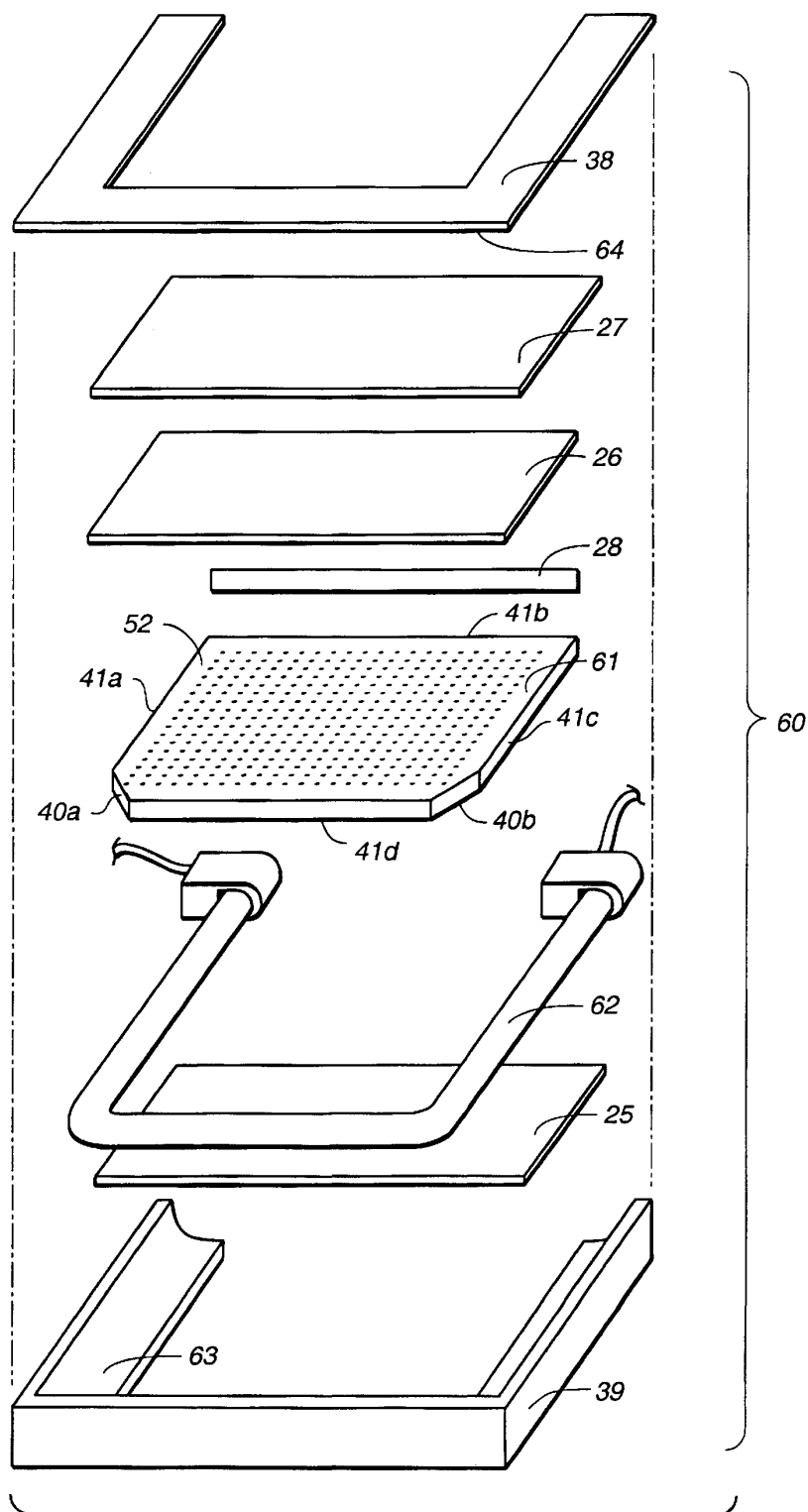

FIG. 15

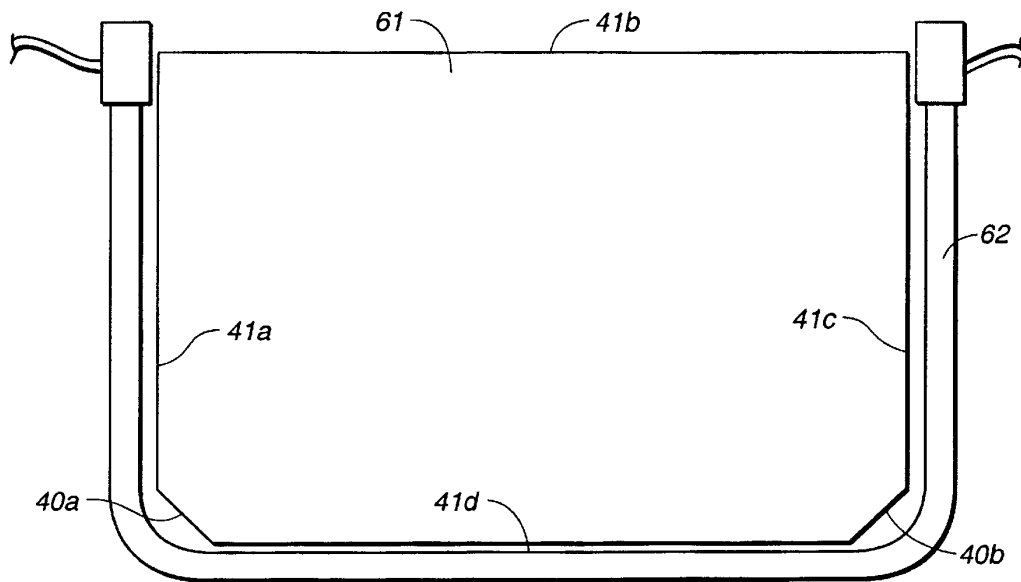

FIG. 16

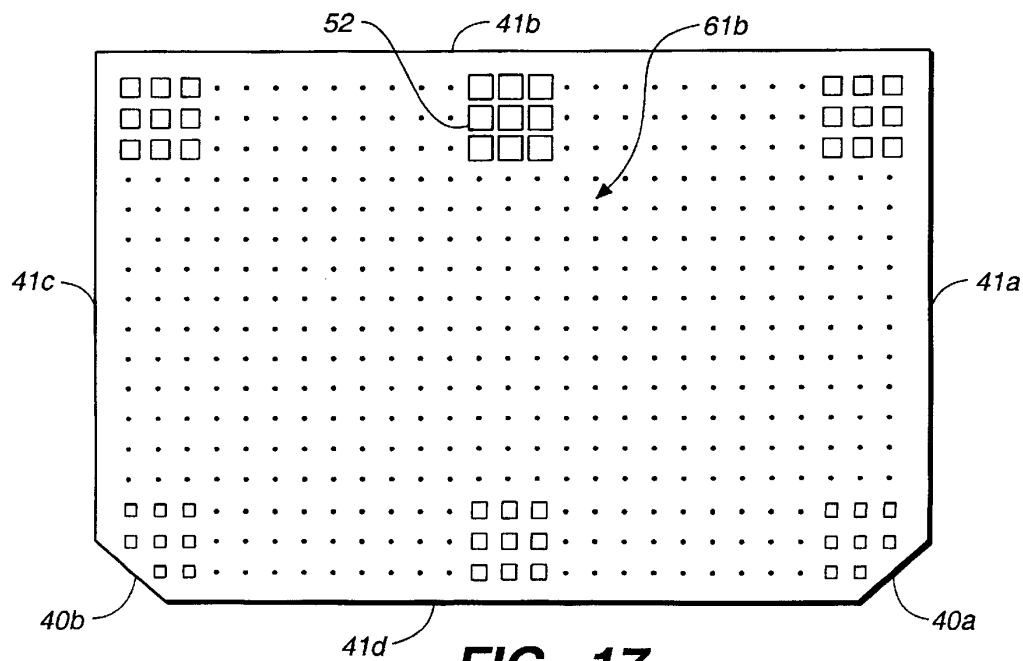

FIG. 17

FIG._18

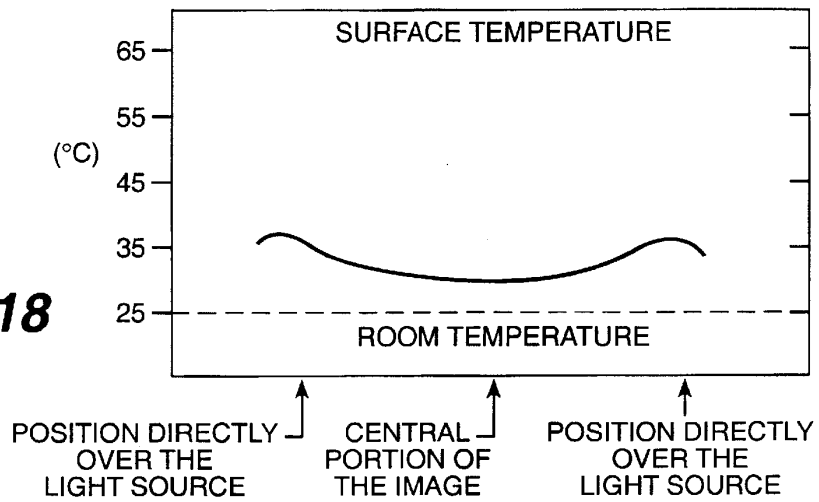

FIG._19

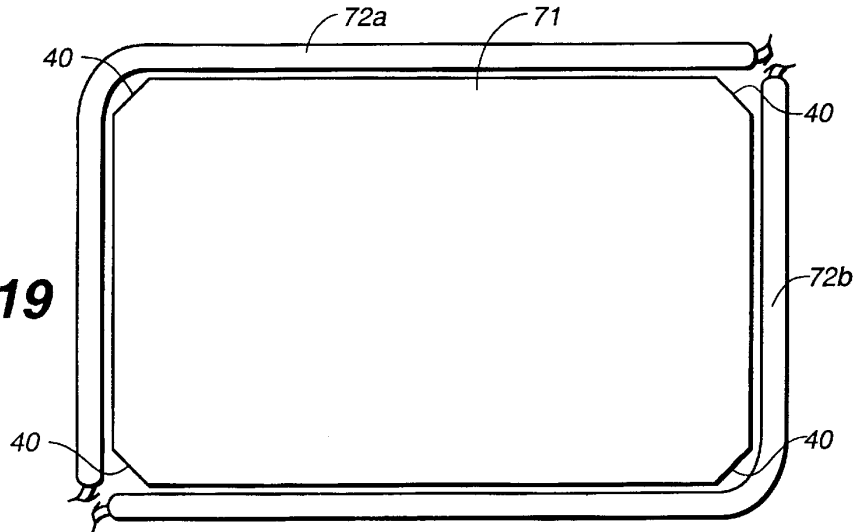
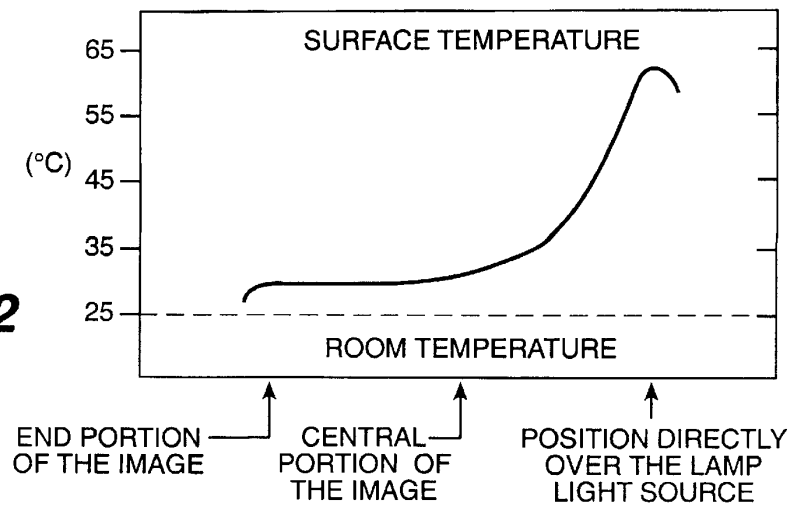

FIG._22



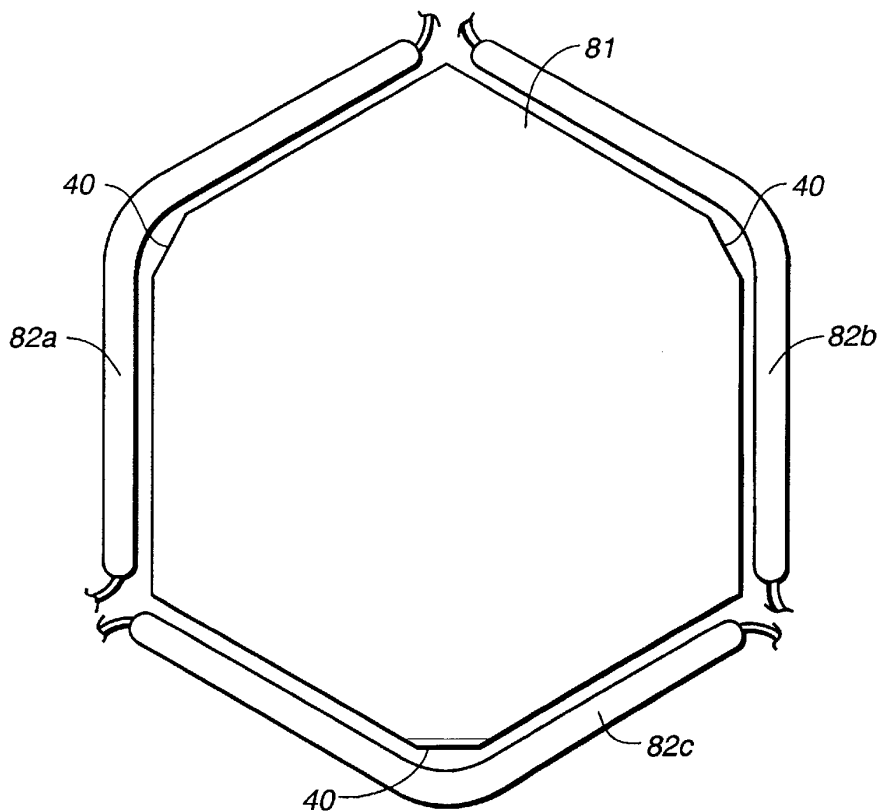

FIG._20

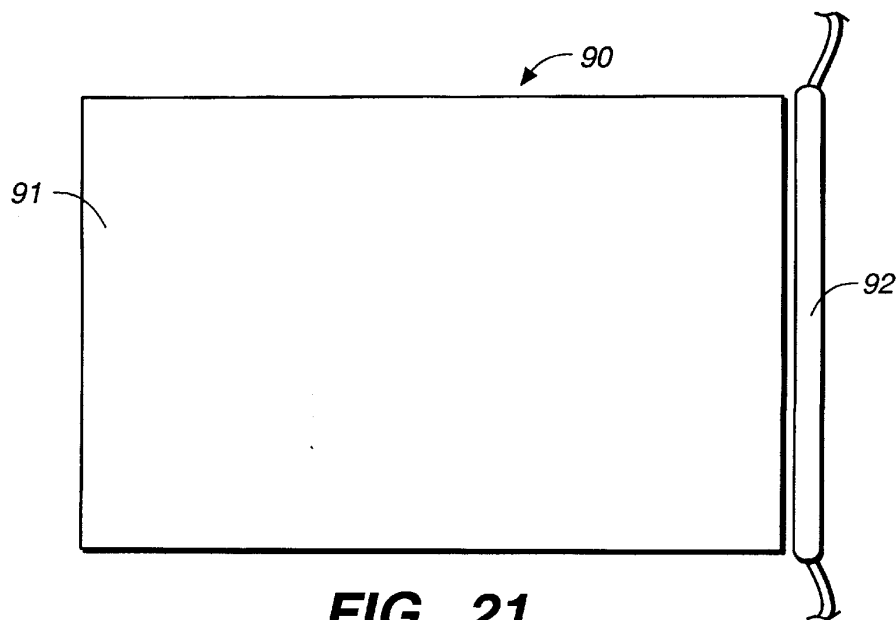

FIG._21

SURFACE-TYPE ILLUMINATION DEVICE AND LIQUID CRYSTAL DISPLAY

CROSS-REFERENCE TO RELATED APPLICATIONS

This is a Divisional of prior application Ser. No. 08/689,424 filed Aug. 9, 1996, now U.S. Pat. No. 5,949,505, which is a Division of application Ser. No. 08/204,374 filed May 10, 1994, now U.S. Pat. No. 5,619,351. Application Ser. Nos. 08/689,424 and 08/204,374 are incorporated herein by reference in their entirety.

BACKGROUND OF THE INVENTION

This invention relates in general to a thin, surface-type illumination device for providing backlight for liquid crystal displays (LCD) and, in particular, to a suitable illumination device for use in a notebook computer display that provides high brightness with low power consumption as well as to a liquid crystal display that uses this illumination device.

Surface-type illumination devices with a cylindrical light source and a flat light guide plate such as the devices described in Japanese Laid-Open Patent Application No. 60-205576 and Japanese Laid-Open Patent Application No. 61-248079 are well-known. One such example is shown in FIG. 21. In the illumination device 90, cylindrical fluorescent light 92 is positioned on one side of the substantially rectangular and flat light guide plate 91. The light introduced to light guide plate 91 from fluorescent light 92 is reflected by the diffusion pattern printed on light guide plate 91 and emitted from the surface of the light guide plate at a fixed density of light.

This type of surface illumination device, in recent years, has been used extensively to provide backlight for liquid crystal display panels. Liquid crystal display panels are increasingly used as displays in such devices as laptop computers, televisions and cameras. The use of liquid crystal display panels for color displays is also increasing. As the size of personal computers and televisions become smaller, it is imperative that liquid crystal display panels become thinner and lighter.

Accordingly, it is necessary that the surface-type illumination device used for liquid crystal display panels to provide backlight, along with the color displays, becomes thinner and lighter with less power consumption. Also, to use in color displays, a sufficient brightness is necessary to clearly show the colors displayed in the liquid crystal. This requires the use of a high output fluorescent light in the illumination device. However, along with the light, heat is also radiated from the high-output fluorescent light. The effect of this heat, as shown in FIG. 22, is significant. The temperature may rise 30-40° C. above a normal temperature of 25° C. Consequently, when this type of illumination device is used for providing backlight in an MIM active color display panel or in an STN passive color display panel, a special method to reduce the heat is necessary to control, to a certain extent, the color and brightness irregularities.

Instead of using one high output fluorescent tube, one may also increase the number of fluorescent tubes. In this way, it is possible to control to some extent the temperature increase due to the light source. However, as the number of fluorescent tubes is increased, many other problems appear. One of these problems is the variations in the illumination of the fluorescent tubes. Because the illumination intensity of fluorescent tubes varies according to each tube, it is necessary to adjust such things as the resistance within the fluorescent tube driver circuit to obtain a fixed illumination intensity.

Consequently, in the case when several fluorescent tubes are used in one illumination device, extra time is required during the manufacturing process to obtain a balanced and fixed illumination intensity.

Another problem is the increased number of driver circuits required to turn on the fluorescent tubes. The number of these driver circuits can not be easily increased in devices such as microcomputers where thinness and small size are important.

SUMMARY OF THE INVENTION

In accordance with the instant invention, a suitable illumination device for color liquid crystal displays can be obtained that is small in size, lightweight, and has high and uniform brightness. Further, it is an object of the invention to provide a surface-type illumination device that can prevent heat generation and its resulting bad effects to the liquid crystal display panel.

Another object of the invention is to provide a surface-type illumination device that, without increasing the number of driver circuits for driving the fluorescent lights, displays a brightness higher than that in conventional illumination devices and restricts heat radiation.

A further object of the invention is to generate a suitable diffusion pattern to realize a surface-type illumination device, this diffusion pattern being used in the illumination device.

Still another object of the invention is to provide a stable liquid crystal display where the driver IC for driving the liquid crystal display panel is positioned so that it will not be affected by heat.

In accordance with the instant invention, by employing an illuminant longer than conventional illuminants, illumination with high illumination intensity is obtained without increasing the number of driver circuits for driving the illuminants and without concentrating the heat diffusion. Further, by bending the illuminant, light can be introduced along the polygon-shaped light guide plate. Also, to maintain proper space between the light guide plate and the illuminant and to increase the efficiency of the light introduced to the light guide plate, a corner is removed from an edge of the light guide plate. According to the invention, the surface-type illumination device comprises a light guide plate which is polygon-shaped and substantially transparent; a diffusion pattern arranged on one surface of the light guide plate for substantially evenly emitting light, the light being introduced from the illuminant to the other surface of the light guide plate; and a cylindrically-shaped illuminant bent so that the illuminant faces at least two sides of the light guide plate; wherein the edge between the two sides is processed so that the corner does not protrude.

By using an illuminant bent along the light guide plate, the length of the cylindrically-shaped illuminant is long, and an illuminant with large illuminating area can be used. Consequently, the rise in temperature of the illuminant can be kept down and high brightness can be obtained. Furthermore, the number of driver circuits for driving the illuminant can be decreased. When an illuminant such as a fluorescent light is bent to adjust for interference between the bent portion and the corner of the light guide plate, the width or length of the entire illumination device becomes longer, preventing miniaturization. In the instant invention, by removing a corner of the light guide plate, the distance between the light guide plate and the illuminant can be kept within a fixed range for high incident efficiency, and thus, a highly efficient illumination device that is small in size can be realized.

Further, by using a long illuminant as mentioned above, an improvement in the conversion efficiency from power to light is also attained. For example, in illuminants such as a fluorescent light, the power to the illuminant is consumed by the cathode drop, which is due to the glow discharge, and by positive column gradient voltage, which is due to light emission. When a plurality of illuminants are used and the input voltage increased, the portion consumed by the cathode drop voltage significantly increases and an increase in the positive column gradient tendency for light emission is small. However, in the illumination device of the instant invention, which uses a long illuminant, power is efficiently converted into light as the increase in the positive column gradient voltage is smaller than in the case when the number of illuminants is increased.

The edge of the light guide plate can be processed into many different shapes, for example, the corner in the shape of an isosceles triangle can be removed. In the case of the isosceles triangle, a high incident efficiency of light from the illuminant to the light guide plate can be maintained. It is desirable to make the length of one of the sides of the isosceles triangle in the approximate range of 0.6 times to 1.0 times the smallest radius of curvature of the bent portion of the illuminant so as to realize a small-sized illumination device. Also, in order to prevent light incident from the edge, and to increase the uniformity of the light radiated from the light guide plate, it is effective to include a shield at the edge portion to prevent introduction of light from the illuminant.

Also, the corner of the edge in a diamond-shape may be removed. In order to make the incident efficiency high and keep the size of the device small, it is desirable to make the length of one of the sides of the removed corner in a diamond-shape within a range of 0.6 times to 1.0 times the smallest radius of curvature of the bent portion of the illuminant. Also, if all the corners are removed from the edges of the light guide plate so that they do not protrude, the directionality of the light guide plate disappears and the manufacturing process time for positioning the light guide plate is saved.

It is common to cover the illuminant with a reflector to increase the incident efficiency of the light from the illuminant to the light guide plate. When a bent illuminant such as the one described above is used, it is desirable for the reflector to include a straight first reflector and a second reflector positioned along two sides of the light guide plate such that at the edge the first reflector is covered by the second reflector. It is also possible for the reflector to include a first reflector that covers the lower half portion of the illuminant on one side of the light guide plate and a second reflector that covers the upper half of the illuminant from the other side of the light guide plate.

The diffusion pattern that diffuses light incident to the light guide plate from the bent illuminant can be generated by the following method. To generate a diffusion pattern that evenly radiates, from the other side of the light guide plate, light introduced from the illuminant to the light guide plate in an illumination device where a cylindrically-shaped illuminant is positioned near at least a first side and a second side of a substantially rectangular light guide plate, the density distribution per unit area of the diffusion pattern can be found by the following method: finding a predicted emitted light intensity distribution for the y-direction along the first side based on the intensity of the light incident to the light guide plate from the second side and the density distribution of a presupposed diffusion pattern; then finding a predicted emitted light intensity distribution for the x-direction along the second side based on the intensity of

the light incident to the light guide plate from the first side and the density distribution of the presupposed diffusion pattern; and then compensating the density distribution of the presupposed diffusion pattern so that the sum of the predicted emitted light intensity distribution for the x-direction and the predicted emitted light intensity distribution for the y-direction on arbitrary rectangular xy coordinates of the light guide plate fit within a fixed range.

When an edge reflector is installed at at least one of the two sides opposite to the first side and the second side, respectively, for reflecting the light from the inner part of the light guide plate to the light guide plate, it is desirable to compensate the density distribution by computing the reflected light intensity incident from the edge reflector to the light guide plate with a fixed attenuation factor; finding a predicted emitted light intensity distribution for at least one of the x and y directions of the reflected light intensity; and adding this to the predicted emitted light intensity distribution found above.

By printing the diffusion pattern described above on the light guide plate or by putting on the light guide plate a sheet with the pattern formed on it, light introduced from the bent illuminant can be evenly radiated from the light guide plate. Similarly, light can be evenly emitted by making the thickness of a light guide plate with an even diffusion pattern inversely proportion to the compensated density distribution of the diffusion pattern.

Effects of the heat from the illuminant can be minimized by using as a bent illuminant an L-shaped illuminant and by placing in a position opposite to the illuminant a driver device such as a driver IC for driving the liquid crystal display. Consequently, as the threshold value of the driver does not become unstable due to the heat, a color display with stable contrast is obtained. Further, a high quality display with high brightness and a small illumination device are also obtained.

Further, a stable, high quality display can be obtained that reduces heat using an even longer U-shaped illuminant. The brightness of the display is easy to adjust when illuminants such as L-shaped and U-shaped illuminants are used because nearly the same intensity of light is incident from the periphery of the light guide plate. Of course, an O-shaped illuminant can also be arranged around the periphery of a rectangular light guide plate as well as an illuminant bent to fit the shape of any other polygon.

Other objects and attainments together with a fuller understanding of the invention will become apparent and appreciated by referring to the following description and claims taken in conjunction with the accompanying drawings.

BRIEF DESCRIPTION OF THE DRAWINGS

FIG. 1 is a sketch of a liquid crystal display using the surface-type illumination device in accordance with the first embodiment of the invention.

FIG. 2 is a cross-sectional view of FIG. 1 showing the structure of the liquid crystal display.

FIG. 3 is a break-down view showing the structure of the liquid crystal display shown in FIG. 1.

FIG. 4 is a break-down view showing the construction of the surface-type illumination device used in the liquid crystal display shown in FIG. 1.

FIG. 5 is a top plan view illustrating the combination of the surface-type illumination device shown in FIG. 4 and the liquid crystal display panel.

FIG. 6 is an explanatory drawing showing the positioning of the light guide plate and fluorescent light of the surface-type illumination device of FIG. 4.

FIG. 7 is a cross-sectional view taken along the line VII—VII in FIG. 5 showing the relationship of the light guide plate, fluorescent light, and reflector of the surface-type illumination device of FIG. 4.

FIGS. 8A and 8B illustrate the assembly of the reflector of FIG. 7.

FIG. 9 is an enlarged view of the edge of the light guide plate.

FIGS. 10A–10D show enlarged views of several possible edge formations of the light guide plate.

FIG. 11 is an explanatory drawing showing the diffusion pattern formed on the diffusion sheet which sticks to the light guide plate.

FIG. 12A is a plan view showing a light guide plate whose thickness has been changed.

FIG. 12B is a cross-sectional view showing a light guide plate whose thickness has been changed.

FIG. 13 is a top plan view showing the combination of the liquid crystal display panel and illumination device in accordance with the second embodiment of this invention.

FIG. 14 is a cross-sectional view showing the relationship of the liquid crystal display panel, illumination device, and illuminant as shown in FIG. 13.

FIG. 15 is a break-down view showing the construction of the structure of the surface-type illumination device used in the liquid crystal display shown in FIG. 14.

FIG. 16 is an explanatory drawing showing the relationship of the light guide plate and the fluorescent light which is in the surface-type illumination device of FIG. 15.

FIG. 17 is an explanatory drawing showing the diffusion pattern that is printed on the light guide plate of FIG. 15.

FIG. 18 is a graph showing the surface temperature of the liquid crystal display panel shown in FIG. 13.

FIG. 19 is an explanatory drawing showing another relationship of the light guide plate and the fluorescent light.

FIG. 20 is an explanatory drawing showing still another relationship of the light guide plate and the fluorescent light.

FIG. 21 is an explanatory drawing showing a conventional light guide plate and fluorescent light.

FIG. 22 is a graph showing the surface temperature of a liquid crystal display panel using a surface-type illumination device similar to the one shown in FIG. 21.

DESCRIPTION OF THE PREFERRED EMBODIMENTS

EMBODIMENT 1

FIG. 1 is a sketch of liquid crystal display 1 in accordance with one embodiment of this invention. Liquid crystal display 1 is constructed with liquid crystal display panel 10 and an illumination device to be described later sandwiched between upper case 2 and lower case 3. Upper case 2 and lower case 3 are fixed in place by tooth 4. The scanning data that comprises the image is supplied from the host side to each row or column through tape electrode 5 and tape electrode 6. This data is latched by a driver IC which will be described below, is synchronized, and is supplied to liquid crystal display panel 10 where the image is formed. Power is supplied from the driver circuit of the host side to the fluorescent light comprising the illumination device through connector 7, connector 7 extending past liquid crystal display 1 and used for initiating lighting.

The basic structure of one embodiment of liquid crystal display 1 will be explained using the cross-sectional view of liquid crystal display 1 shown in FIG. 2 and the break-down view of liquid crystal display 1 shown in FIG. 3. In liquid crystal display 1, illumination device 20 is installed in lower case 3. Above device 20, liquid crystal display panel 10 is installed using frames 30 and 31. Liquid crystal display panel 10 is formed by enclosing the liquid crystal, transparent electrodes, etc. between two layers of transparent glass substrates 11 and 12. At side 10a of liquid crystal display panel 10, a plurality of driver ICs 13 are installed for latching pixel data for the rows and sending it to the liquid crystal display panel. Also, at side 10b, which is adjacent to side 10a, a plurality of driver ICs 14 are installed for latching pixel data for the columns and sending it to the liquid crystal display panel.

Frames 30 and 31 are used to protect illumination device 20 and to position it within the case. At the same time, it also fills the role of maintaining a fixed distance for gap 33 between illumination device 20 and liquid crystal display panel 10, for example, 0.2–1 mm. For this reason, frames 30 and 31 are prepared so that their lower halves 34 and 35 support illumination device 20 and their upper halves 36 and 37 act as spacers between illumination device 20 and liquid crystal display panel 10. In this example the frame is divided into two pieces, however, the number of pieces is not limited to two. For example, three pieces, four pieces, or even more is possible, and even just one piece is also possible. Furthermore, the frame need not cover the entire periphery of illumination device 20 or liquid crystal display panel 10. A plurality of pieces may be arranged in appropriate places.

Illumination device 20 is a surface-type illumination device set up with a cylindrically-shaped fluorescent light 22 at the edge of substantially rectangular light guide plate 21. Fluorescent light 22 is roughly L-shaped and is covered by reflectors 23a and 23b. Wires for supplying power to drive fluorescent light 22 extend from both ends of fluorescent light 22 and are connected to the driver circuit on the host side through connector 7 which is for turning on the light. FIG. 4 is a break-down view of illumination device 20 and will be used to explain the structure of the illumination device of this embodiment. Illumination device 20 is comprised of light guide plate 21, which is substantially rectangular in shape and has the corner of at edge 40 missing, fluorescent light 22, which encompasses edge 40 in an L-shape, and reflectors 23a and 23b, which cover fluorescent light 22 in the direction of light guide plate 21 and efficiently reflect light from fluorescent light 22 to light guide plate 21. On lower surface 21b of light guide plate 21, i.e., the side opposite to the side where liquid crystal display panel 10 is arranged, pattern sheet 24, which is printed with diffusion pattern 50, and reflecting sheet 25 are arranged in that order. On upper surface 21a of light guide plate 21, i.e., the side where liquid crystal display panel 10 is arranged, diffusion sheet 26 and prism sheet 27 are arranged. Edge reflective tape 28 is put on edge 41a and 41b, opposite to fluorescent light 22 of light guide plate 21.

Light guide plate 21 is a transparent material whose index of refraction is greater than that of air. An index of refraction equal to or greater than 1.41 is desirable using such materials as acrylic resin, polycarbonate resin, amorphous polyolefine-type resin, and polystyrene resin. Use of these types of materials for light guide plate 21 results in a critical angle of 45° or less. If upper surface 21a and lower surface 21b are smooth and mirror-like, the light incident from edges 41a, 41b, 41c, and 41d, which are formed at right angles to surface 21a and 21b, is completely reflected from surfaces 21a and 21b.

Pattern sheet 24 is a transparent sheet with a fixed number of diffusion patterns 50 printed on it, the printed diffusion patterns being adhered to lower surface 21b of light guide plate 21. Light incident from sides 41, to some extent, reaches diffusion pattern 50 and, without being completely reflected, will be diffused in the direction of upper surface 21a. Consequently, light incident from the fluorescent light by way of the edges is emitted to liquid crystal display panel 10 from upper surface 21a.

Reflecting sheet 25 is a thin PET sheet with a thickness of approximately 0.05–0.5 mm. Light coming from upper surface 21a of light guide plate 21 through diffusion pattern 50 travels through diffusion sheet 26 and prism sheet 27, which are arranged on the upper portion of upper surface 21a and light up liquid crystal display panel 10. However, a portion of the light is reflected from sheets 26 and 27 in the lower direction. The light reflected from the upper direction is returned to light guide plate 21, among others, through reflecting sheet 25 among others. Reflecting sheet 25 may be aluminum or other non-PET material. Also, lower case 3 may be used as a reflector in place of a reflecting sheet. Further, the frame of a computer or similar part carrying the illumination device or liquid crystal display can also be used as a reflector in place of the reflecting sheet.

Diffusion sheet 26 is an approximately 0.05–0.5 mm thin PET sheet or PC sheet. Diffusion sheet 26 diffuses the light that is reflected by diffusion pattern 50 and radiated from upper surface 21a. Diffusion pattern 50 is often formed in a narrow line configuration or net configuration. The light that is reflected by these types of patterns is diffused by diffusion sheet 26. The diffusion pattern cannot be recognized from liquid crystal display panel 10. Diffusion sheet 26 is arranged with a very small layer of air between it and upper surface 21a of light guide plate 21. The angle mentioned above is maintained in regards to the angle of upper surface 21a. Reflection sheet 26 is not limited to a PET sheet and such sheets as acrylic-type sheets, among others, may be used.

Prism sheet 27, which is arranged on diffusion sheet 26, is made up of very small linear prisms lined in a cross-sectional array. The angle of the light radiating from diffusion sheet 26 is arranged to improve the illuminating intensity of liquid crystal display panel 10. Although the brightness can be improved through prism sheet 27, when sufficient brightness is achieved through diffusion sheet 26, prism sheet 27 can be omitted, thus reducing manufacturing cost.

Fluorescent light 22, which is used as the light source of illumination device 20, is in an L-shape, and is positioned adjacent to edges 41c and 41d of light guide plate 21. It is desirable, as will be explained later, to maintain a gap between edges 41c and 41d and fluorescent light 22 of around 0.8–1.5 mm. The corner of edge 40 of light guide plate 21 is removed and fluorescent light 22 is able to be positioned with the above noted gap. Also, by removing this corner, fluorescent light 22 and the corner of light guide plate 21 are prevented from touching and damage to the fluorescent light can be prevented.

Fluorescent light 22 is covered by reflectors 23a and 23b to make the light discharged from fluorescent light 22 incident with good efficiency from edge 40 of light guide plate 21. Reflectors 23a and 23b are PET sheets deposited with silver and of a thickness of approximately 0.01–0.1 mm. In order to provide low cost reflectors that cover the L-shaped fluorescent light and that are easy to install, two straight reflectors are used. This will be explained in greater detail below.

Edge reflective tape 28 is arranged at two edges 41a and 41b, which are opposite to edges 41c and 41d, respectively, where fluorescent light 22 and reflector 23 are installed. Edge reflective tape 28 is a PET sheet deposited with silver with thickness of approximately 0.01–0.1 mm. The light introduced to light guide plate 21 from fluorescent light 22 is completely reflected away. The light that reaches the edges of the opposite side is returned to light guide plate 21. Materials such as white PET sheets and aluminum can be used for the edge reflective tape as well as the reflectors mentioned above. It is also possible to integrate these into a case or frame.

FIG. 5 shows liquid crystal display panel 10 installed on illumination device 20. Driver ICs 13 and 14 are arranged on sides 10a and 10b, respectively, adjacent to liquid crystal display panel 10. Opposite to sides 10a and 10b, L-shaped fluorescent light 22 extends along two sides 20c and 20d of illumination device 20. Because of this arrangement, driver ICs 13 and 14 are not directly influenced by the heat from fluorescent light 22. Consequently, the temperature of the driver ICs does not rise significantly, preventing changes in the driver's threshold value. For this reason, an image with very low fluctuations in contrast can be obtained using liquid crystal display panel 10.

By using a light like the L-shaped fluorescent light 22 shown in FIG. 6, the temperature distribution of the entire liquid crystal display panel 10 becomes flat. In order to illuminate liquid crystal display panel 10 for color displays, high brightness is essential. Because of this, as explained earlier in connection with FIG. 22, the output of conventional fluorescent lights that are installed at one edge is increased and the slope of the temperature distribution of the liquid crystal display panel becomes large. This results in color and brightness irregularities and poor display quality. However, by introducing light from two edges, as in the instant invention, a rise in the temperature of the liquid crystal display panel can be suppressed and high brightness can be obtained.

When introducing light from two edges, it is possible to use two fluorescent lights. This makes it possible to limit the increase in the temperature of the liquid crystal display panel as compared to the method of introducing light from only one edge. However, as two driver circuits would be necessary to drive the two fluorescent lights, it would not be desirable to incorporate them into small personal computers and televisions. In the instant invention, temperature rise can be suppressed and a high brightness can be obtained without increasing the number of driver circuits.

Also, because the light conversion efficiency can be increased by using an L-shaped fluorescent light, temperature rise can be further limited. The majority of the power input into the fluorescent light is consumed as a cathode drop voltage which generates glow discharge. For example, when two fluorescent lights are used, two times the power is required, with most of it being consumed in order to generate two glow discharges. However, when a long fluorescent light is used, such as in the instant invention, the cathode drop voltage consumed by glow discharge does not increase that much. Because of this, when two times the power is supplied, most of the increased power is consumed as a positive column gradient voltage in generating light. Consequently, the same brightness can be obtained with lower voltage and lower temperature rise. For this reason, the rise of the temperature of the liquid crystal display panel can be held down and a good quality image can be obtained. Also, because the power consumption can be kept down, it is a suitable illumination device for illumination in liquid

crystal display panels in small, portable devices where batteries are used as the power source.

There are many merits in the illumination device of the instant invention which uses L-shaped fluorescent light 22. However, it is not as easy as just installing L-shaped fluorescent light 22 at edge 40 of light guide plate 21. This is because corner 43 of rectangular-shaped light guide plate 21 (when the corner has not been removed) and bent portion 22a of fluorescent light 22 interfere with each other and therefore, gap 42 between edge 41 and fluorescent light 22 becomes exceedingly large. When gap 42 cannot be reduced, the entire illumination device 20 becomes larger and the scale of the liquid crystal display cannot be reduced. Also, when the gap between edge 41 and fluorescent light 22 becomes larger, the light introduced to edge 41 decreases. Reflector 23 can, to some extent, prevent the decrease of the light from fluorescent light 22, but a large reflector is required. However, in light guide plate 21 of the instant invention, at edge 40, corner 43 which interferes with fluorescent light 22, is removed so that the corner does not stick out and gap 42 is reduced. By removing the corner at edge 40, damage to fluorescent light 22 due to corner 43 impacting fluorescent light 22 during shipping can be prevented. Also, damage to fluorescent light 22 caused by thermal expansion of light guide plate 21, vibration, etc. can be prevented.

Gap 42 between edge 41 and fluorescent light 22 is not completely eliminated. Not only do problems with precision during product manufacturing exist, but if gap 42 is reduced too much, the light reflected to reflector 23 is absorbed by fluorescent light 22 and the introduction efficiency to surface 41 is reduced. In FIG. 7, the light radiated from fluorescent light 22 to the opposite side at edge 40 is reflected by reflector 23 and introduced to edge 40. Consequently, if gap 42 is too small, the reflected light is introduced to fluorescent light 22 and completely absorbed within fluorescent light 22 and, thus, the amount of light introduced to edge 40 is reduced. If gap 42 is large, the incident efficiency improves, but when the width of gap 42 exceeds a prescribed value, the increase in the incident efficiency becomes less to the extent that limiting the size of illumination device 20 becomes more desirable. An appropriate gap 42 is judged by this inventor to be approximately 0.8–1.5 mm. More specifically, in the case of fluorescent light 22 with a diameter of 2.5–4 mm, a gap of around 1–1.5 mm is desirable.

The light reflected from reflector 23 is an important light source for illumination device 20. Although there are several different ways of setting up a reflector with respect to bent fluorescent light 22 of the instant invention, one method, as shown in FIG. 8, is to use two reflectors 23a and 23b which are made from flat material and bent in a nearly half circular shape. Reflector 23a corresponds to the short side of light guide plate 21 and is long enough to cover from bent portion 22a to electrode 22b of the short side of bent fluorescent light 22. Likewise, reflector 23b corresponds to the long side of light guide plate 21 and is long enough to cover from bent portion 22a to electrode 22c on the long side of bent fluorescent light 22. At the time of manufacturing illumination device 20, one of the reflectors, for example, the shorter reflector 23a is first arranged. If the other reflector, for example, longer reflector 23b, is laid from the top of the first reflector to the other side fluorescent light 22 can be completely covered. In this way, two separate reflectors 23a and 23b can be used to easily cover bent fluorescent light 22 and assembly of the reflectors is made easy. Also, in conforming to the bent-shape of fluorescent light 22, reflectors 23a and 23b do not have a complex shape, but rather, a simple

straight-line shape is used and therefore manufacturing cost can be kept down.

The aperture ratio is vital to increasing the incident efficiency from fluorescent light 22 to edge 40. A desirable range for this aperture ratio, which is defined as (thickness of light guide plate 21)/(diameter of fluorescent light 22), is around 0.9–2. If the aperture ratio is higher, the incident efficiency does not improve much.

The removal of different shapes of the corner at edge 40 is possible. In this embodiment of the invention, a corner in the shape of an isosceles triangle is removed from edge 40. Edge 43, which makes an angle of approximately 45° with respect to both edges 41c and 41d, is formed by edge 40. Because the light directly incident to edges 41c and 41d from fluorescent light 22 is reflected at edge 40, the influence of this portion to the intensity of the light radiated from upper surface 21a of light guide plate 21 is small. The influence of this removed shape to the uniformity of the brightness is also small. However, with the scattered light that differs in the incident angle, there is a possibility that the brightness uniformity incident from edge 43 and radiated from upper surface 21 will be hindered. In the instant invention, reflecting member 44 is mounted to prevent light incident to light guide plate 21 from edge 43. A plastic sheet deposited with white, silver, or aluminum among others or even a molded part can be used as reflecting member 44. This reflects light rays and prevents them from leaving light guide plate 21 and passing through edge 43, and at its opposite side, it shields light rays coming from fluorescent light 22, maintaining brightness uniformity. As edge 40 becomes larger, the light introduced from light guide plate 21 is reduced in the vicinity of the edge. Consequently, in order to maintain uniformity of brightness, it is desirable to establish limitations for the size of the triangle shape that will be removed. On one hand, if too little is removed, gap 42 between fluorescent light 22 and edge 41 cannot be properly maintained. In considering this, it is found desirable to make the length of the two substantially equal sides of the triangle to be within the range of 0.6 to 1.0 times the smallest radius of curvature of bent portion 22a of fluorescent light 22.

FIG. 10 shows other shape variations that are used in other embodiments of the invention. FIGS. 10A and 10B are examples of the corner removed from edge 40 which is parallel to adjacent sides 41c and 41d. In order to make this type of shape, edge 40 should be cut in a diamond shape, or in a square shape if the light guide plate is rectangular. Edges 45a and 45b, which are obtained after cutting a diamond-shaped corner, are approximately parallel to adjacent edges 41c and 41d of light guide plate 21. Consequently, the light introduced to light guide plate 21 from these edges 45a and 45b have substantially the same vector as edges 41c and 41d, and the probability of light being incident from the edges or being emitted from the edges is substantially the same. Therefore, it is rare for edge 40 to exert an influence on the uniformity of the brightness of the light radiated from the illumination device. For this reason, even if reflecting member 44 is omitted, it is still possible to obtain uniform brightness. However, it is difficult to maintain good uniformity if the gap between the edge and the fluorescent light becomes large. In considering the fluorescent light and interference, it is found to be desirable to make the length of one of the diamond-shaped sides, as noted above, to be within the range of 0.6 to 1.0 times the smallest radius of curvature of bent portion 22a of fluorescent light 22.

FIGS. 10C and 10D show other examples of the shape of edge 40 when the manufacturing process of light guide plate

11

21 is considered. In the case of injection formation of light guide plate 21 and from the aspect of type processing, a "fan-shape" as shown in FIG. 10C can be used. In the case of machining light guide plate 21 to form edge 40, an "opposite fan-shape" is possible. Of course, other shapes are also possible.

FIG. 11 shows diffusion pattern 50 for emitting light introduced to light guide plate 21 from bent fluorescent light 22 to the liquid crystal display panel through upper surface 21a of light guide plate 21. Although in this embodiment diffusion pattern 50 is printed on pattern sheet 42, it is also possible to print the pattern directly on lower surface 21b of light guide plate 21. It also is, of course, possible to draw diffusion pattern 50 on the lower surface of light guide plate 21 by using such methods as etching. Although line patterns and dot patterns are most commonly used, other patterns, as well as increasing or decreasing the pattern area density at different places are also possible.

In the case of the dot diffusion pattern, a method of increasing or decreasing the area of each dot or a method of increasing or decreasing the dot density is possible for adjusting the area density of the pattern. FIG. 11 shows an example of a pattern where the area of the dots are increased or decreased. The dot areas are small near edges 41c and 41d where fluorescent light 22 is positioned and these areas gradually increase as they move towards the opposing edges 41a and 41b. The dots near edge 40 which is near bent portion 22a of fluorescent light 22 have the smallest areas and the dots on the corner opposite to this between edge 41a and 41b have the largest areas.

The density distribution $S(x,y)$ of this diffusion pattern is described below. Here, x and y are coordinates along edges 41c and 41d of fluorescent light 22, and a coordinate axis is used that increases in the direction away from fluorescent light 22. For some small areas, the density distribution of a diffusion pattern is assumed in advance to be S_{x,y_j} . The intensity $I_{1,1}$ of the light diffused by the diffusion pattern of density distribution S_{x,y_j} as it relates to the light incident from the x direction with an intensity of Lx is represented by the following equation, where k is a reflection coefficient.

$$I_{1,1} = Lx \times S_{x,y_j} \times k \quad (1)$$

The intensity of the light diffused at the next small area in the x direction, $I_{2,1}$, is represented by the following equation.

$$I_{2,1} = (Lx - I_{1,1}) \times S_{x,y_j} \times k \quad (2)$$

Similarly, the intensity $I_{1,j}$ of the light diffused by the diffusion pattern of density distribution S_{x,y_j} and emitted by each small area as it relates to the light incident from the y direction with an intensity of Ly is represented by the following equation.

$$I_{1,j} = (Ly - \sum_{i=1}^{j-1} I_{1,i}) \times S_{x,y_j} \times k + (Ly - \sum_{i=1}^{j-1} I_{1,i}) \times S_{x,y_j} \times k \quad (3)$$

The average intensity radiated, I_{ave} , is represented by the following equation, where n is the number of the small areas in the x axis direction and m is the number of the small areas in the y axis direction.

$$I_{ave} = \sum_{i=1}^n \sum_{j=1}^m I_{i,j} / (n \times m) \quad (4)$$

Keeping the intensity of the light diffused by the diffusion pattern in a fixed range is necessary in order to make the

12

brightness of illumination device 20 uniform. Consequently, the density distribution S_{x,y_j} of the diffusion pattern assumed in advance must be compensated and is represented by the following equation.

$$S^1_{x,y_j} = S_{x,y_j} \times I_{ave} / \sum I_{i,j} \quad (5)$$

Just as above, the intensity of the light diffused at each small area using the compensated density distribution S^1_{x,y_j} of the diffusion pattern is recalculated. If this intensity can be kept within the permitted range, a diffusion pattern with proper brightness uniformity will be generated. If, despite using the once compensated density distribution S^1_{x,y_j} , the intensity of the light is not kept within the fixed range, repeat the compensation with the above technique.

In this way, when the diffusion pattern is generated, based on the intensity of the incident light in both the x and y directions, the intensity of the light emitted by diffusion at each coordinate, or each small area, is calculated for all directions. Along with finding the light intensity emitted at each small area that composes the intensity, the average light intensity is found and the density distribution of the diffusion pattern is compensated so that variations of the light intensity emitted from each small area will be kept within the average light intensity and fixed range.

Further, it is desirable to compensate for the intensity of the light reflected from edge reflective tape 28 which is placed on edges 41a and 41b. For the intensity of the light reflected from edge 41a and 41b by edge reflective tape, it is appropriate to add the intensity of the light that is diffused and emitted to the calculation of $I_{i,j}$, the intensity of light emitted from each small area.

The following is an equation for Lx , the intensity of light reflected from edge 41a in the x direction.

$$Lx' = (Lx - \sum_{i=1}^n I_{i,1}) \times \eta \quad (6)$$

In this equation, η is the reflection coefficient of the edge reflective tape. A number, for example, such as 0.5 may be used. Consequently, by performing a further calculation to that discussed above, a density distribution of the diffusion pattern compensated for the edge reflection can be obtained for the light source of the intensity incident from coordinate x_a in the x direction. And, by using diffusion pattern 50 which follows this density distribution, illumination with a high uniform brightness can be achieved through the light guide plate.

FIGS. 12A and 12B show an example of increasing and decreasing the thickness of the light guide plate instead of forming a diffusion pattern that differs in density on the light guide plate. In this example of light guide plate 29, diffusion pattern 51, which has a fixed density distribution, is printed on lower surface 29b. The cross section of light guide plate 29 is formed such that it is inversely proportional to the density distribution of the diffusion pattern discussed above.

In other words, edges 41c and 41d of light guide plate 29 are thick and the thickness become gradually thinner in the direction of edges 41a and 41b. When the thickness of light guide plate 29 is thinned in inverse proportion to the density distribution of the diffusion pattern as above, the density of the light, which is illuminated by the diffusion pattern of uniform density formed on lower surface 29b, increases. Consequently, the intensity of the light diffused by diffusion pattern and emitted from upper surface 29a is averaged the same as the light emitted by the diffusion pattern with the density distribution as described above. A light guide plate such as light guide plate 29 shown in FIG. 12 can, therefore, also achieve illumination with high uniform brightness.

Illumination device 20, as explained above, uses as its light source one long fluorescent light that is bent in an L-shape and can be installed at the light guide plate which has a corner removed. Consequently, the effective overall length of the fluorescent light can be extended and the gross luminous energy increased without increasing the number of the driver circuits used for turning on the fluorescent light. Also, when there are a plurality of fluorescent lights, the necessity to adjust such things as the driver circuits so that the brightness of the plurality of fluorescent lights are in agreement does not exist. Further, because the light conversion efficiency can be increased, power consumption can be reduced. In regard to the output of the driver circuit for turning on the fluorescent light, although it is necessary to increase the output ability because the overall length of the fluorescent light is extended, when compared with the case of turning on two fluorescent lights, the output of the driver circuit is still low.

Illumination device 20 can be used in various ways as a surface-type illuminant in addition to the liquid crystal display discussed above. When used to provide backlight in a liquid crystal display panel, the fluorescent light can be arranged in a place opposite to the liquid crystal driver IC because an L-shape fluorescent light is used. For this reason, the effects of heat from the illuminant to the driver IC can be kept to a minimum and a stable display can be obtained. Also, as the illuminant and driver IC have no positional interferences, the size of the liquid crystal display can be reduced. Further, the power consumption of the illumination system is low, the heating power per unit length is low as the illuminating portion is long, and the temperature rise of the liquid crystal panel can, to a great extent, be kept down. Consequently, when high brightness necessary for color displays is shown, color and brightness irregularities of the liquid crystal panel can be prevented and a good quality, vivid color display can be obtained.

Further, to simplify the manufacturing process and obtain a display with uniform illumination and good display quality for the illumination device and the liquid crystal display, many things such as the shape of the reflector and the generation method of the diffusion pattern are improved and a low-cost liquid crystal display with good display quality is provided.

In the above, only one corner from edge 40 of the light guide plate is removed. However, it is also possible to remove all four corners. If all four corners of the same shape are removed, the directionality of the light guide plate becomes unimportant at the time of assembly and the manufacturing process can be further simplified.

EMBODIMENT 2

FIG. 13 shows a liquid crystal display using an illumination device 60, which differs from that described above, and liquid crystal panel 10 installed on illumination device 60. The drawings and descriptions which are substantially similar to the embodiment shown in FIG. 1 are eliminated. Also, the same reference numbers for liquid crystal display panel 10 and other parts that are in common with the first embodiment will be used and the descriptions will be eliminated.

Illumination device 60 uses a U-shaped fluorescent light 62 as a light source. Fluorescent light 62 is positioned next to edges 41a, 41c and 41d on light guide plate 61 of illumination device 60. Illumination device 60 is enclosed within frames 38 and 39, which are upper and lower sections, respectively. Upper frame 38 acts as a spacer to secure the gap between liquid crystal display panel 10 and illumination device 60.

The construction of illumination device 60 of this embodiment will be explained with reference to FIGS. 14 and 15. Within the U-shaped lower frame 39 of illumination device 60 are enclosed the following in the order from bottom to top, reflecting sheet 25, light guide plate 61, diffusion sheet 26, and prism sheet 27. U-shaped fluorescent light 62 is installed next to three of the edges of light guide plate 61, 41a, 41c, and 41d. The remaining edge 41b is attached with edge reflective tape 28. On top of lower frame 39, which encloses all of these, is the flat, U-shaped upper frame 38.

The mirror surface of the hyperbolic curve section of the inner surface 63 of lower frame 39 is formed by silver deposition or the like. The lower surface 64 of upper frame 38 is also silver deposited and mirrorized. The inner surface 63 and lower surface 64 of frames 39 and 38, respectively, function as a reflector. Thus, the reflector and frame described in the previous embodiment are integrated into one part. Consequently, the problems associated with assembling illumination device 60 is further reduced.

The explanation of the functions of reflection sheet 25, diffusion sheet 26, and prism 27 will be omitted as they are the same as that explained in the earlier embodiment. In this example, the pattern sheet is omitted because the diffusion sheet 52 is printed on lower surface 61b of light guide plate 61. The two corners are removed from edges 40a and 40b of light guide plate 61 in order to install U-shaped fluorescent light 62 with an appropriate gap 42 from the light guide plate, as explained in the embodiment above. FIG. 16 shows the relationship between fluorescent light 62 and light guide plate 61. The corner of edge 40b, which is between edges 41c and 41d, and the corner of edge 40a, which is between edges 41a and 41d, are removed so that they do not stick out. In this way, fluorescent light 62 can be installed with fixed gap 42 from edges 41, and the incident efficiency towards light guide plate 61 can be maintained at a high level. Also, damage to fluorescent light 62 caused by thermal expansion, shock etc. can be prevented. The shape of the removed corner, in this example, is a triangle with two sides of approximately equal length. However, as explained earlier, it is also possible to use other shapes.

FIG. 17 shows diffusion pattern 52, which is printed on lower side 61b of light guide plate 61. Diffusion pattern 52 is formed using the density distribution obtained by the generation method discussed above. In this embodiment, because in addition to the light source from edge 41c there is a light source from edge 41a, the area density of the diffusion pattern on this side is low and the area density of the diffusion pattern in the middle of lower surface 61b is high. Also, the area density of the diffusion pattern along edge 41d is low, and the area density of the diffusion pattern opposite to this side near edge 41b is high. Through diffusion pattern 52, the light introduced to light guide plate 61 is diffused and a uniform light is emitted from upper surface 61a of light guide plate 61 towards the liquid crystal display panel.

FIG. 18 shows the temperature distribution on liquid crystal display panel 10 of this embodiment. From this graph it can be seen that the temperature rise of that portion of the panel directly opposite to the fluorescent light increases only about 10 degrees above the regular temperature. As shown in FIG. 22, this is a significant reduction as compared with the temperature rise in a conventional illumination device. Because of the very small difference between the temperature of the central portion of the liquid crystal display panel and the temperature of the edge portions near the light source and the resulting flat temperature distribution, there

15

is a very small amount of image and brightness irregularities that appear on the liquid crystal display panel. Consequently, a good quality image can be obtained. Therefore, illumination device 60 is an illumination device that can irradiate a light of high brightness for color displays and can prevent a temperature rise on the liquid crystal display panel. Because of the use of a long light source bent in a U-shape, the amount of heating per unit length can be reduced and, still further, a reduction in power consumption can be achieved.

In the present embodiment of the liquid crystal display device, as shown in FIG. 13, driver IC 13 is arranged on one of the sides of the U-shaped fluorescent light. However, because the rise in temperature of fluorescent light 62 is small, thermal expansion towards driver IC is small and problems such as fluctuations in the threshold value can be controlled. Consequently, by using the liquid crystal display of this embodiment, a vivid and stable color image with high brightness can be obtained and low power consumption can be achieved. As only one driver circuit is necessary to turn on the fluorescent light, devices that use liquid crystal displays, such as televisions and personal computers, can be miniaturized. Because the discharge length is increased, the driver circuit output must be improved to turn on the U-shaped fluorescent light. However, as compared to turning on three separate fluorescent lights, the increase in the output of the driver circuit is small.

FIG. 19 shows an example of two approximately L-shaped fluorescent lights 72a and 72b installed on light guide plate 71. FIG. 20 shows three approximately L-shaped fluorescent lights 82a, 82b, and 82c installed on hexagonal light guide plate 81. The corners are removed from the edge portions 40 of both light guide plates 71 and 81 so that there is no interference with fluorescent lights 72 and 82 and these lights can be properly positioned. Structures discussed in the above embodiments, such as those of the reflectors, can also be used here.

Various shapes of surface-type illumination systems can be formed using a bent, cylindrical illuminant. With these illumination devices, a uniform illumination device with high brightness can be obtained that has low power consumption. Also, a high quality color display can be obtained when a color liquid crystal display panel is used.

The surface-type illumination device of the invention is suitable for providing backlight in liquid crystal display devices that use a liquid crystal display panel or for using as other flat, surface-type illumination devices. Because liquid crystal display devices using this illumination device can display vivid color with low power consumption, it can be used as a display in notebook PCs and other information processing devices as well as in devices such as liquid crystal TVs, video cameras, and other image processing devices.

While the invention has been described in conjunction with several specific embodiments, it is evident to those skilled in the art that many further alternatives, modifications and variations will be apparent in light of the foregoing description. Thus, the invention described herein is intended to embrace all such alternatives, modifications, applications and variations as may fall within the spirit and scope of the appended claims.

What is claimed is:

1. An illumination device comprising:

a substantially transparent and polygon-shaped light guide plate comprising at least first and second side edges;

an elongated illuminant comprising an L-shaped section facing said at least first and second side edges of said light guide plate;

16

said light guide plate comprising a cutout portion at a corner between said first and second side edges so as not to interfere with a facing bend in said L-shaped section of said elongated illuminant;

said cutout portion comprising a first leg and a second leg, said first leg being substantially parallel to said second side edge, and said second leg being substantially parallel to said first side edge.

2. An illumination device according to claim 1 comprising a gap distance in a range of about 0.8 to 1.5 mm formed between at least one of said first and second side edges and said facing illuminant.

3. An illumination device according to claim 2 wherein said gap distance is in a range of about 1.0 to 1.5 mm.

4. An illumination device according to claim 1 wherein an aperture ratio, defined as a thickness of said light guide plate/a diameter of said illuminant, is in the range of about 0.9 to 2.0.

5. An illumination device according to claim 1 further comprising a reflecting member covering said cutout portion.

6. An illumination device according to claim 1 wherein the length of one of said first and second legs is approximately 0.6 times to 1.0 times the smallest radius of curvature of said facing bend in said L-shaped illuminant.

7. An illumination device according to claim 1 further comprising a reflector covering said illuminant except in regions of said illuminant facing said first and second side edges of said light guide plate, said reflector comprising a first reflector portion and a second reflector portion positioned along legs of said L-shaped section of said illuminant.

8. An illumination device according to claim 1 further comprising a reflector covering said illuminant except in regions of said illuminant facing said first and second side edges of said light guide plate, said reflector comprising a first portion covering a lower portion of said illuminant and a second portion covering an upper portion of said illuminant.

9. An illumination device according to claim 1 wherein said light guide has a thickness formed so that it is inversely proportional to a density distribution calculated by:

computing a first predicted emitted light intensity distribution for a first direction along said first side edge based on the intensity of the light incident on said light guide plate from said second side edge and the density distribution of a presupposed diffusion pattern;

computing a second predicted emitted light intensity distribution for a second direction along said second side edge based on the intensity of the light incident on said light guide plate from said first side and the density distribution of the presupposed diffusion pattern; and

computing the density distribution of said diffusion pattern by compensating the density distribution of the presupposed diffusion pattern so that the sum of said first predicted emitted light intensity distribution and said second predicted emitted light intensity distribution on arbitrary rectangular coordinates of said light guide plate fit within a fixed range.

10. An illumination device according to claim 9 further comprising an edge reflector disposed along at least one of

17

two side edges of said light guide plate opposite to said first side edge and said second side edge, said edge reflector reflecting the light emitted by said light guide plate back to said light guide plate; and the density distribution of said diffusion pattern is computed by:

5 computing an intensity of light reflected by said edge reflector and incident on said light guide plate with a fixed attenuation factor;

10 computing a predicted emitted light intensity distribution for at least one of the first and second directions for said reflected light intensity; and

15 adding the predicted emitted light intensity distribution to the sum of said first predicted emitted light intensity distribution and said second predicted emitted light intensity distribution which are on arbitrary rectangular coordinates of said light guide plate.

18

11. An illumination device according to claim 1 further comprising a liquid crystal display that is illuminated by light emitted from one side of said light guide plate by a diffusion pattern formed on the other side of said light guide plate; and

a driver that drives said liquid crystal display, said driver arranged along two side edges of said light guide plate opposing said first and second side edges of said light guide plate.

12. An illumination device according to claim 1 wherein said illuminant is substantially U-shaped and faces said first and second side edges and a third side edge of said light guide plate.

* * * * *

UNITED STATES PATENT AND TRADEMARK OFFICE
CERTIFICATE OF CORRECTION

PATENT NO. : 6,108,060
DATED : August 22, 2000
INVENTOR(S) : Tatsuaki Funamoto et al.

It is certified that error appears in the above-identified patent and that said Letters Patent is hereby corrected as shown below:

On the title page, item 30, Foreign Application Priority Data, please add --July 13, 1992 [JP] Japan 4-184976--.

Signed and Sealed this
Twenty-ninth Day of May, 2001

Attest:

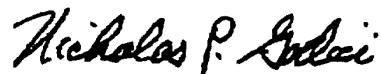

NICHOLAS P. GODICI

Attesting Officer

Acting Director of the United States Patent and Trademark Office

PATENT APPLICATION SERIAL NO. _____

U.S. DEPARTMENT OF COMMERCE
PATENT AND TRADEMARK OFFICE
FEE RECORD SHEET

06/14/1999 TDADE1 00000025 192746 09321687
01 FC:101 760.00 CH

PTO-1556
(5/87)

*U.S. GPO: 1998-433-214/80404

LGE_000888

P1933.D2



APPLICATION
FOR
UNITED STATES LETTERS PATENT

Be it known that we, Tatsuaki Funamoto, Toru Yagasaki, and Fumiaki Akahane, all citizens of Japan, of 3-5 Owa 3-chome, Suwa-shi, Nagano-ken, 392 Japan, c/o Seiko Epson Corporation, have invented new and useful improvements in:

**SURFACE-TYPE ILLUMINATION DEVICE AND LIQUID CRYSTAL
DISPLAY**

of which the following is the specification:

09321587 052899

CERTIFICATION UNDER 37 C.F.R. 1.10

"Express Mail" Label Number: EL034498298US
Date of Deposit: May 28, 1999

I hereby certify that this patent application is being deposited with the United States Postal Service on this date in an envelope as "Express Mail Post Office to Addressee" service under 37 C.F.R. 1.10 on the date indicated above and is addressed to the Assistant Commissioner for Patents, Washington, DC 20231.

Shellie Bailey
Shellie Bailey

09-321,657

P1933.D2

Abstract

5 A surface-type illumination device suitable for providing backlight in a liquid
crystal display is disclosed. For example, an L-shaped fluorescent light can be used
as an illuminant and mounted next to two edges of a substantially rectangular light
guide plate. The corner of an edge portion between the two edges is removed. The
fluorescent light, the length of whose illuminating portion is long, is positioned with
an appropriate gap from the light guide plate allowing for illumination with high
brightness and low power consumption. Consequently, when the illumination
device is used in a color liquid crystal display, appropriate backlight with high
10 brightness can be obtained. Moreover, because the influence of the temperature
from the illumination device is small, a stable color display can be achieved.

09-321,657

P1933.D2

SURFACE-TYPE ILLUMINATION DEVICE AND LIQUID CRYSTAL DISPLAY

Inventors: Tatsuaki Funamoto
Toru Yagasaki
5 Fumiaki Akahane

Cross-Reference to Related Applications

This is a Divisional of pending prior application Serial No. 08/689,424 filed August 9, 1996, ^{now U.S. Pat. No. 5,949,505} which is a Division of application Serial No. 08/204,374 filed May 10, 1994, now U.S. Patent No. 5,619,351. Application Serial Nos. 08/689,424 and 08/204,374 are incorporated herein by reference in their entirety.

BACKGROUND OF THE INVENTION

This invention relates in general to a thin, surface-type illumination device for providing backlight for liquid crystal displays (LCD) and, in particular, to a suitable illumination device for use in a notebook computer display that provides high brightness with low power consumption as well as to a liquid crystal display that uses this illumination device.

Surface-type illumination devices with a cylindrical light source and a flat light guide plate such as the devices described in Japanese Laid-Open Patent Application No. 60-205576 and Japanese Laid-Open Patent Application No. 61-248079 are well-known. One such example is shown in FIG. 21. In the illumination device 90, cylindrical fluorescent light 92 is positioned on one side of the substantially rectangular and flat light guide plate 91. The light introduced to light guide plate 91 from fluorescent light 92 is reflected by the diffusion pattern printed on light guide plate 91 and emitted from the surface of the light guide plate at a fixed density of light.

This type of surface illumination device, in recent years, has been used extensively to provide backlight for liquid crystal display panels. Liquid crystal display panels are increasingly used as displays in such devices as laptop computers, televisions and cameras. The use of liquid crystal display panels for color displays is also increasing. As the size of personal computers and televisions become smaller, it is imperative that liquid crystal display panels become thinner and lighter.

Accordingly, it is necessary that the surface-type illumination device used for liquid crystal display panels to provide backlight, along with the color displays, becomes thinner and lighter with less power consumption. Also, to use in color displays, a sufficient brightness is necessary to clearly show the colors displayed in the liquid crystal. This requires the use of a high output fluorescent light in the

P1933.D2

illumination device. However, along with the light, heat is also radiated from the high-output fluorescent light. The effect of this heat, as shown in FIG. 22, is significant. The temperature may rise 30-40°C above a normal temperature of 25°C. Consequently, when this type of illumination device is used for providing backlight
5 in an MIM active color display panel or in an STN passive color display panel, a special method to reduce the heat is necessary to control, to a certain extent, the color and brightness irregularities.

Instead of using one high output fluorescent tube, one may also increase the number of fluorescent tubes. In this way, it is possible to control to some extent the
10 temperature increase due to the light source. However, as the number of fluorescent tubes is increased, many other problems appear. One of these problems is the variations in the illumination of the fluorescent tubes. Because the illumination intensity of fluorescent tubes varies according to each tube, it is necessary to adjust such things as the resistance within the fluorescent tube driver circuit to obtain a fixed illumination intensity. Consequently, in the case when several fluorescent tubes are used in one illumination device, extra time is required during the manufacturing process to obtain a balanced and fixed illumination intensity.

Another problem is the increased number of driver circuits required to turn
20 on the fluorescent tubes. The number of these driver circuits can not be easily increased in devices such as microcomputers where thinness and small size are important.

Summary of the Invention

In accordance with the instant invention, a suitable illumination device for
25 color liquid crystal displays can be obtained that is small in size, lightweight, and has high and uniform brightness. Further, it is an object of the invention to provide a surface-type illumination device that can prevent heat generation and its resulting bad effects to the liquid crystal display panel.

Another object of the invention is to provide a surface-type illumination
30 device that, without increasing the number of driver circuits for driving the fluorescent lights, displays a brightness higher than that in conventional illumination devices and restricts heat radiation.

A further object of the invention is to generate a suitable diffusion pattern to
35 realize a surface-type illumination device, this diffusion pattern being used in the illumination device.

Still another object of the invention is to provide a stable liquid crystal display where the driver IC for driving the liquid crystal display panel is positioned so that it will not be affected by heat.

P1933.D2

In accordance with the instant invention, by employing an illuminant longer than conventional illuminants, illumination with high illumination intensity is obtained without increasing the number of driver circuits for driving the illuminants and without concentrating the heat diffusion. Further, by bending the illuminant, light can be introduced along the polygon-shaped light guide plate. Also, to maintain proper space between the light guide plate and the illuminant and to increase the efficiency of the light introduced to the light guide plate, a corner is removed from an edge of the light guide plate. According to the invention, the surface-type illumination device comprises a light guide plate which is polygon-shaped and substantially transparent; a diffusion pattern arranged on one surface of the light guide plate for substantially evenly emitting light, the light being introduced from the illuminant to the other surface of the light guide plate; and a cylindrically-shaped illuminant bent so that the illuminant faces at least two sides of the light guide plate; wherein the edge between the two sides is processed so that the corner does not protrude.

By using an illuminant bent along the light guide plate, the length of the cylindrically-shaped illuminant is long, and an illuminant with large illuminating area can be used. Consequently, the rise in temperature of the illuminant can be kept down and high brightness can be obtained. Furthermore, the number of driver circuits for driving the illuminant can be decreased. When an illuminant such as a fluorescent light is bent to adjust for interference between the bent portion and the corner of the light guide plate, the width or length of the entire illumination device becomes longer, preventing miniaturization. In the instant invention, by removing a corner of the light guide plate, the distance between the light guide plate and the illuminant can be kept within a fixed range for high incident efficiency, and thus, a highly efficient illumination device that is small in size can be realized.

Further, by using a long illuminant as mentioned above, an improvement in the conversion efficiency from power to light is also attained. For example, in illuminants such as a fluorescent light, the power to the illuminant is consumed by the cathode drop, which is due to the glow discharge, and by positive column gradient voltage, which is due to light emission. When a plurality of illuminants are used and the input voltage increased, the portion consumed by the cathode drop voltage significantly increases and an increase in the positive column gradient tendency for light emission is small. However, in the illumination device of the instant invention, which uses a long illuminant, power is efficiently converted into light as the increase in the positive column gradient voltage is smaller than in the case when the number of illuminants is increased.

P1933.D2

5 The edge of the light guide plate can be processed into many different shapes, for example, the corner in the shape of an isosceles triangle can be removed. In the case of the isosceles triangle, a high incident efficiency of light from the illuminant to the light guide plate can be maintained. It is desirable to make the length of one of the sides of the isosceles triangle in the approximate range of 0.6 times to 1.0 times the smallest radius of curvature of the bent portion of the illuminant so as to realize a small-sized illumination device. Also, in order to prevent light incident from the edge, and to increase the uniformity of the light radiated from the light guide plate, it is effective to include a shield at the edge portion to prevent
10 introduction of light from the illuminant.

Also, the corner of the edge in a diamond-shape may be removed. In order to make the incident efficiency high and keep the size of the device small, it is desirable to make the length of one of the sides of the removed corner in a diamond-shape within a range of 0.6 times to 1.0 times the smallest radius of curvature of the bent portion of the illuminant. Also, if all the corners are removed from the edges of the light guide plate so that they do not protrude, the directionality of the light guide plate disappears and the manufacturing process time for positioning the light guide plate is saved.

15 It is common to cover the illuminant with a reflector to increase the incident efficiency of the light from the illuminant to the light guide plate. When a bent illuminant such as the one described above is used, it is desirable for the reflector to include a straight first reflector and a second reflector positioned along two sides of the light guide plate such that at the edge the first reflector is covered by the second reflector. It is also possible for the reflector to include a first reflector that covers
20 the lower half portion of the illuminant on one side of the light guide plate and a second reflector that covers the upper half of the illuminant from the other side of the light guide plate.

25 The diffusion pattern that diffuses light incident to the light guide plate from the bent illuminant can be generated by the following method. To generate a diffusion pattern that evenly radiates, from the other side of the light guide plate, light introduced from the illuminant to the light guide plate in an illumination device where a cylindrically-shaped illuminant is positioned near at least a first side and a second side of a substantially rectangular light guide plate, the density distribution per unit area of the diffusion pattern can be found by the following
30 method: finding a predicted emitted light intensity distribution for the y-direction along the first side based on the intensity of the light incident to the light guide plate from the second side and the density distribution of a presupposed diffusion pattern; then finding a predicted emitted light intensity distribution for the x-direction along the second side based on the intensity of the light incident to the
35

P1933.D2

light guide plate from the first side and the density distribution of the presupposed diffusion pattern; and then compensating the density distribution of the presupposed diffusion pattern so that the sum of the predicted emitted light intensity distribution for the x-direction and the predicted emitted light intensity
5 distribution for the y-direction on arbitrary rectangular xy coordinates of the light guide plate fit within a fixed range.

When an edge reflector is installed at at least one of the two sides opposite to the first side and the second side, respectively, for reflecting the light from the inner part of the light guide plate to the light guide plate, it is desirable to compensate
10 the density distribution by computing the reflected light intensity incident from the edge reflector to the light guide plate with a fixed attenuation factor; finding a predicted emitted light intensity distribution for at least one of the x and y directions of the reflected light intensity; and adding this to the predicted emitted light intensity distribution found above.

By printing the diffusion pattern described above on the light guide plate or by putting on the light guide plate a sheet with the pattern formed on it, light introduced from the bent illuminant can be evenly radiated from the light guide plate. Similarly, light can be evenly emitted by making the thickness of a light
15 guide plate with an even diffusion pattern inversely proportion to the compensated density distribution of the diffusion pattern.
20

Effects of the heat from the illuminant can be minimized by using as a bent illuminant an L-shaped illuminant and by placing in a position opposite to the illuminant a driver device such as a driver IC for driving the liquid crystal display. Consequently, as the threshold value of the driver does not become unstable due to
25 the heat, a color display with stable contrast is obtained. Further, a high quality display with high brightness and a small illumination device are also obtained.

Further, a stable, high quality display can be obtained that reduces heat using an even longer U-shaped illuminant. The brightness of the display is easy to adjust when illuminants such as L-shaped and U-shaped illuminants are used
30 because nearly the same intensity of light is incident from the periphery of the light guide plate. Of course, an O-shaped illuminant can also be arranged around the periphery of a rectangular light guide plate as well as an illuminant bent to fit the shape of any other polygon.

Other objects and attainments together with a fuller understanding of the
35 invention will become apparent and appreciated by referring to the following description and claims taken in conjunction with the accompanying drawings.

Brief Description of the Drawings

FIG. 1 is a sketch of a liquid crystal display using the surface-type illumination device in accordance with the first embodiment of the invention.

5 FIG. 2 is a cross-sectional view of FIG. 1 showing the structure of the liquid crystal display.

FIG. 3 is a break-down view showing the structure of the liquid crystal display shown in FIG. 1.

FIG. 4 is a break-down view showing the construction of the surface-type illumination device used in the liquid crystal display shown in FIG. 1.

10 FIG. 5 is a top plan view illustrating the combination of the surface-type illumination device shown in Fig. 4 and the liquid crystal display panel.

FIG. 6 is an explanatory drawing showing the positioning of the light guide plate and fluorescent light of the surface-type illumination device of FIG. 4.

15 FIG. 7 is a cross-sectional view taken along the line VII-VII in FIG. 5 showing the relationship of the light guide plate, fluorescent light, and reflector of the surface-type illumination device of FIG. 4.

FIGS. 8A and 8B illustrate the assembly of the reflector of FIG. 7.

FIG. 9 is an enlarged view of the edge of the light guide plate.

20 FIGS. 10A-10D show enlarged views of several possible edge formations of the light guide plate.

FIG. 11 is an explanatory drawing showing the diffusion pattern formed on the diffusion sheet which sticks to the light guide plate.

FIG. 12A is a plan view showing a light guide plate whose thickness has been changed.

25 FIG. 12B is a cross-sectional view showing a light guide plate whose thickness has been changed.

FIG. 13 is a top plan view showing the combination of the liquid crystal display panel and illumination device in accordance with the second embodiment of this invention.

30 FIG. 14 is a cross-sectional view showing the relationship of the liquid crystal display panel, illumination device, and illuminant as shown in FIG. 13.

FIG. 15 is a break-down view showing the construction of the structure of the surface-type illumination device used in the liquid crystal display shown in FIG. 14.

35 FIG. 16 is an explanatory drawing showing the relationship of the light guide plate and the fluorescent light which is in the surface-type illumination device of FIG. 15.

FIG. 17 is an explanatory drawing showing the diffusion pattern that is printed on the light guide plate of FIG. 15.

P1933.D2

FIG. 18 is a graph showing the surface temperature of the liquid crystal display panel shown in FIG. 13.

FIG. 19 is an explanatory drawing showing another relationship of the light guide plate and the fluorescent light.

5 FIG. 20 is an explanatory drawing showing still another relationship of the light guide plate and the fluorescent light.

FIG. 21 is an explanatory drawing showing a conventional light guide plate and fluorescent light.

10 FIG. 22 is a graph showing the surface temperature of a liquid crystal display panel using a surface-type illumination device similar to the one shown in FIG. 21.

Description of the Preferred Embodiments

EMBODIMENT 1

15 FIG. 1 is a sketch of liquid crystal display 1 in accordance with one embodiment of this invention. Liquid crystal display 1 is constructed with liquid crystal display panel 10 and an illumination device to be described later sandwiched between upper case 2 and lower case 3. Upper case 2 and lower case 3 are fixed in place by tooth 4. The scanning data that comprises the image is supplied from the host side to each row or column through tape electrode 5 and tape electrode 6. This data is latched by a driver IC which will be described below, is synchronized, and is supplied to liquid crystal display panel 10 where the image is formed. Power is supplied from the driver circuit of the host side to the fluorescent light comprising the illumination device through connector 7, connector 7 extending past liquid crystal display 1 and used for initiating lighting.

20
25
30
35 The basic structure of one embodiment of liquid crystal display 1 will be explained using the cross-sectional view of liquid crystal display 1 shown in FIG. 2 and the break-down view of liquid crystal display 1 shown in FIG. 3. In liquid crystal display 1, illumination device 20 is installed in lower case 3. Above device 20, liquid crystal display panel 10 is installed using frames 30 and 31. Liquid crystal display panel 10 is formed by enclosing the liquid crystal, transparent electrodes, etc. between two layers of transparent glass substrates 11 and 12. At side 10a of liquid crystal display panel 10, a plurality of driver ICs 13 are installed for latching pixel data for the rows and sending it to the liquid crystal display panel. Also, at side 10b, which is adjacent to side 10a, a plurality of driver ICs 14 are installed for latching pixel data for the columns and sending it to the liquid crystal display panel.

Frames 30 and 31 are used to protect illumination device 20 and to position it within the case. At the same time, it also fills the role of maintaining a fixed distance for gap 33 between illumination device 20 and liquid crystal display panel

P1933.D2

10, for example, 0.2 - 1 mm. For this reason, frames 30 and 31 are prepared so that their lower halves 34 and 35 support illumination device 20 and their upper halves 36 and 37 act as spacers between illumination device 20 and liquid crystal display panel 10. In this example the frame is divided into two pieces, however, the number of pieces is not limited to two. For example, three pieces, four pieces, or even more is possible, and even just one piece is also possible. Furthermore, the frame need not cover the entire periphery of illumination device 20 or liquid crystal display panel 10. A plurality of pieces may be arranged in appropriate places.

5
10
15
20
25
Illumination device 20 is a surface-type illumination device set up with a cylindrically-shaped fluorescent light 22 at the edge of substantially rectangular light guide plate 21. Fluorescent light 22 is roughly L-shaped and is covered by reflectors 23a and 23b. Wires for supplying power to drive fluorescent light 22 extend from both ends of fluorescent light 22 and are connected to the driver circuit on the host side through connector 7 which is for turning on the light. FIG. 4 is a break-down view of illumination device 20 and will be used to explain the structure of the illumination device of this embodiment. Illumination device 20 is comprised of light guide plate 21, which is substantially rectangular in shape and has the corner of at edge 40 missing, fluorescent light 22, which encompasses edge 40 in an L-shape, and reflectors 23a and 23b, which cover fluorescent light 22 in the direction of light guide plate 21 and efficiently reflect light from fluorescent light 22 to light guide plate 21. On lower surface 21b of light guide plate 21, i.e., the side opposite to the side where liquid crystal display panel 10 is arranged, pattern sheet 24, which is printed with diffusion pattern 50, and reflecting sheet 25 are arranged in that order. On upper surface 21a of light guide plate 21, i.e., the side where liquid crystal display panel 10 is arranged, diffusion sheet 26 and prism sheet 27 are arranged. Edge reflective tape 28 is put on edge 41a and 41b, opposite to fluorescent light 22 of light guide plate 21.

30
35
Light guide plate 21 is a transparent material whose index of refraction is greater than that of air. An index of refraction equal to or greater than 1.41 is desirable using such materials as acrylic resin, polycarbonate resin, amorphous polyolefine-type resin, and polystyrene resin. Use of these types of materials for light guide plate 21 results in a critical angle of 45° or less. If upper surface 21a and lower surface 21b are smooth and mirror-like, the light incident from edges 41a, 41b, 41c, and 41d, which are formed at right angles to surface 21a and 21b, is completely reflected from surfaces 21a and 21b.

Pattern sheet 24 is a transparent sheet with a fixed number of diffusion patterns 50 printed on it, the printed diffusion patterns being adhered to lower surface 21b of light guide plate 21. Light incident from sides 41, to some extent, reaches diffusion pattern 50 and, without being completely reflected, will be

P1933.D2

diffused in the direction of upper surface 21a. Consequently, light incident from the fluorescent light by way of the edges is emitted to liquid crystal display panel 10 from upper surface 21a.

5 Reflecting sheet 25 is a thin PET sheet with a thickness of approximately 0.05 - 0.5 mm. Light coming from upper surface 21a of light guide plate 21 through diffusion pattern 50 travels through diffusion sheet 26 and prism sheet 27, which are arranged on the upper portion of upper surface 21a and light up liquid crystal display panel 10. However, a portion of the light is reflected from sheets 26 and 27 in the lower direction. The light reflected from the upper direction is returned to light guide plate 21, among others, through reflecting sheet 25 among others. Reflecting sheet 25 may be aluminum or other non-PET material. Also, lower case 3 may be used as a reflector in place of a reflecting sheet. Further, the frame of a computer or similar part carrying the illumination device or liquid crystal display can also be used as a reflector in place of the reflecting sheet.

15 Diffusion sheet 26 is an approximately 0.05 - 0.5 mm thin PET sheet or PC sheet. Diffusion sheet 26 diffuses the light that is reflected by diffusion pattern 50 and radiated from upper surface 21a. Diffusion pattern 50 is often formed in a narrow line configuration or net configuration. The light that is reflected by these types of patterns is diffused by diffusion sheet 26. The diffusion pattern cannot be recognized from liquid crystal display panel 10. Diffusion sheet 26 is arranged with a very small layer of air between it and upper surface 21a of light guide plate 21. The angle mentioned above is maintained in regards to the angle of upper surface 21a. Reflection sheet 26 is not limited to a PET sheet and such sheets as acrylic-type sheets, among others, may be used.

20 Prism sheet 27, which is arranged on diffusion sheet 26, is made up of very small linear prisms lined in a cross-sectional array. The angle of the light radiating from diffusion sheet 26 is arranged to improve the illuminating intensity of liquid crystal display panel 10. Although the brightness can be improved through prism sheet 27, when sufficient brightness is achieved through diffusion sheet 26, prism sheet 27 can be omitted, thus reducing manufacturing cost.

25 Fluorescent light 22, which is used as the light source of illumination device 20, is in an L-shape, and is positioned adjacent to edges 41c and 41d of light guide plate 21. It is desirable, as will be explained later, to maintain a gap between edges 41c and 41d and fluorescent light 22 of around 0.8 - 1.5 mm. The corner of edge 40 of light guide plate 21 is removed and fluorescent light 22 is able to be positioned with the above noted gap. Also, by removing this corner, fluorescent light 22 and the corner of light guide plate 21 are prevented from touching and damage to the fluorescent light can be prevented.

P1933.D2

Fluorescent light 22 is covered by reflectors 23a and 23b to make the light discharged from fluorescent light 22 incident with good efficiency from edge 40 of light guide plate 21. Reflectors 23a and 23b are PET sheets deposited with silver and of a thickness of approximately 0.01 - 0.1 mm. In order to provide low cost
5 reflectors that cover the L-shaped fluorescent light and that are easy to install, two straight reflectors are used. This will be explained in greater detail below.

Edge reflective tape 28 is arranged at two edges 41a and 41b, which are opposite to edges 41c and 41d, respectively, where fluorescent light 22 and reflector 23 are installed. Edge reflective tape 28 is a PET sheet deposited with silver with
10 thickness of approximately 0.01 - 0.1 mm. The light introduced to light guide plate 21 from fluorescent light 22 is completely reflected away. The light that reaches the edges of the opposite side is returned to light guide plate 21. Materials such as white PET sheets and aluminum can be used for the edge reflective tape as well as the reflectors mentioned above. It is also possible to integrate these into a case or
15 frame.

FIG. 5 shows liquid crystal display panel 10 installed on illumination device 20. Driver ICs 13 and 14 are arranged on sides 10a and 10b, respectively, adjacent to liquid crystal display panel 10. Opposite to sides 10a and 10b, L-shaped fluorescent light 22 extends along two sides 20c and 20d of illumination device 20.
20 Because of this arrangement, driver ICs 13 and 14 are not directly influenced by the heat from fluorescent light 22. Consequently, the temperature of the driver ICs does not rise significantly, preventing changes in the driver's threshold value. For this reason, an image with very low fluctuations in contrast can be obtained using liquid crystal display panel 10.

By using a light like the L-shaped fluorescent light 22 shown in FIG. 6, the
25 temperature distribution of the entire liquid crystal display panel 10 becomes flat. In order to illuminate liquid crystal display panel 10 for color displays, high brightness is essential. Because of this, as explained earlier in connection with FIG. 22, the output of conventional fluorescent lights that are installed at one edge
30 is increased and the slope of the temperature distribution of the liquid crystal display panel becomes large. This results in color and brightness irregularities and poor display quality. However, by introducing light from two edges, as in the instant invention, a rise in the temperature of the liquid crystal display panel can be suppressed and high brightness can be obtained.

When introducing light from two edges, it is possible to use two fluorescent
35 lights. This makes it possible to limit the increase in the temperature of the liquid crystal display panel as compared to the method of introducing light from only one edge. However, as two driver circuits would be necessary to drive the two fluorescent lights, it would not be desirable to incorporate them into small personal

P1933.D2

computers and televisions. In the instant invention, temperature rise can be suppressed and a high brightness can be obtained without increasing the number of driver circuits.

5 Also, because the light conversion efficiency can be increased by using an L-shaped fluorescent light, temperature rise can be further limited. The majority of the power input into the fluorescent light is consumed as a cathode drop voltage which generates glow discharge. For example, when two fluorescent lights are used, two times the power is required, with most of it being consumed in order to generate two glow discharges. However, when a long fluorescent light is used, such
10 as in the instant invention, the cathode drop voltage consumed by glow discharge does not increase that much. Because of this, when two times the power is supplied, most of the increased power is consumed as a positive column gradient voltage in generating light. Consequently, the same brightness can be obtained with lower voltage and lower temperature rise. For this reason, the rise of the temperature of the liquid crystal display panel can be held down and a good quality image can be obtained. Also, because the power consumption can be kept down, it is a suitable illumination device for illumination in liquid crystal display panels in small, portable devices where batteries are used as the power source.

15
20 There are many merits in the illumination device of the instant invention which uses L-shaped fluorescent light 22. However, it is not as easy as just installing L-shaped fluorescent light 22 at edge 40 of light guide plate 21. This is because corner 43 of rectangular-shaped light guide plate 21 (when the corner has not been removed) and bent portion 22a of fluorescent light 22 interfere with each other and therefore, gap 42 between edge 41 and fluorescent light 22 becomes
25 exceedingly large. When gap 42 cannot be reduced, the entire illumination device 20 becomes larger and the scale of the liquid crystal display cannot be reduced. Also, when the gap between edge 41 and fluorescent light 22 becomes larger, the light introduced to edge 41 decreases. Reflector 23 can, to some extent, prevent the decrease of the light from fluorescent light 22, but a large reflector is required.
30 However, in light guide plate 21 of the instant invention, at edge 40, corner 43 which interferes with fluorescent light 22, is removed so that the corner does not stick out and gap 42 is reduced. By removing the corner at edge 40, damage to fluorescent light 22 due to corner 43 impacting fluorescent light 22 during shipping can be prevented. Also, damage to fluorescent light 22 caused by thermal
35 expansion of light guide plate 21, vibration, etc. can be prevented.

Gap 42 between edge 41 and fluorescent light 22 is not completely eliminated. Not only do problems with precision during product manufacturing exist, but if gap 42 is reduced too much, the light reflected to reflector 23 is absorbed by fluorescent light 22 and the introduction efficiency to surface 41 is

P1933.D2

reduced. In FIG. 7, the light radiated from fluorescent light 22 to the opposite side at edge 40 is reflected by reflector 23 and introduced to edge 40. Consequently, if gap 42 is too small, the reflected light is introduced to fluorescent light 22 and completely absorbed within fluorescent light 22 and, thus, the amount of light introduced to edge 40 is reduced. If gap 42 is large, the incident efficiency improves, but when the width of gap 42 exceeds a prescribed value, the increase in the incident efficiency becomes less to the extent that limiting the size of illumination device 20 becomes more desirable. An appropriate gap 42 is judged by this inventor to be approximately 0.8 - 1.5 mm. More specifically, in the case of fluorescent light 22 with a diameter of 2.5 - 4 mm, a gap of around 1 - 1.5 mm is desirable.

The light reflected from reflector 23 is an important light source for illumination device 20. Although there are several different ways of setting up a reflector with respect to bent fluorescent light 22 of the instant invention, one method, as shown in FIG. 8, is to use two reflectors 23a and 23b which are made from flat material and bent in a nearly half circular shape. Reflector 23a corresponds to the short side of light guide plate 21 and is long enough to cover from bent portion 22a to electrode 22b of the short side of bent fluorescent light 22. Likewise, reflector 23b corresponds to the long side of light guide plate 21 and is long enough to cover from bent portion 22a to electrode 22c on the long side of bent fluorescent light 22. At the time of manufacturing illumination device 20, one of the reflectors, for example, the shorter reflector 23a is first arranged. If the other reflector, for example, longer reflector 23b, is laid from the top of the first reflector to the other side fluorescent light 22 can be completely covered. In this way, two separate reflectors 23a and 23b can be used to easily cover bent fluorescent light 22 and assembly of the reflectors is made easy. Also, in conforming to the bent-shape of fluorescent light 22, reflectors 23a and 23b do not have a complex shape, but rather, a simple straight-line shape is used and therefore manufacturing cost can be kept down.

The aperture ratio is vital to increasing the incident efficiency from fluorescent light 22 to edge 40. A desirable range for this aperture ratio, which is defined as (thickness of light guide plate 21) / (diameter of fluorescent light 22), is around 0.9 - 2. If the aperture ratio is higher, the incident efficiency does not improve much.

The removal of different shapes of the corner at edge 40 is possible. In this embodiment of the invention, a corner in the shape of an isosceles triangle is removed from edge 40. Edge 43, which makes an angle of approximately 45° with respect to both edges 41c and 41d, is formed by edge 40. Because the light directly incident to edges 41c and 41d from fluorescent light 22 is reflected at edge 40, the influence of this portion to the intensity of the light radiated from upper surface 21a

P1933.D2

of light guide plate 21 is small. The influence of this removed shape to the uniformity of the brightness is also small. However, with the scattered light that differs in the incident angle, there is a possibility that the brightness uniformity incident from edge 43 and radiated from upper surface 21 will be hindered. In the instant invention, reflecting member 44 is mounted to prevent light incident to light guide plate 21 from edge 43. A plastic sheet deposited with white, silver, or aluminum among others or even a molded part can be used as reflecting member 44. This reflects light rays and prevents them from leaving light guide plate 21 and passing through edge 43, and at its opposite side, it shields light rays coming from fluorescent light 22, maintaining brightness uniformity. As edge 40 becomes larger, the light introduced from light guide plate 21 is reduced in the vicinity of the edge. Consequently, in order to maintain uniformity of brightness, it is desirable to establish limitations for the size of the triangle shape that will be removed. On one hand, if too little is removed, gap 42 between fluorescent light 22 and edge 41 cannot be properly maintained. In considering this, it is found desirable to make the length of the two substantially equal sides of the triangle to be within the range of 0.6 to 1.0 times the smallest radius of curvature of bent portion 22a of fluorescent light 22.

FIG. 10 shows other shape variations that are used in other embodiments of the invention. FIGS. 10A and 10B are examples of the corner removed from edge 40 which is parallel to adjacent sides 41c and 41d. In order to make this type of shape, edge 40 should be cut in a diamond shape, or in a square shape if the light guide plate is rectangular. Edges 45a and 45b, which are obtained after cutting a diamond-shaped corner, are approximately parallel to adjacent edges 41c and 41d of light guide plate 21. Consequently, the light introduced to light guide plate 21 from these edges 45a and 45b have substantially the same vector as edges 41c and 41d, and the probability of light being incident from the edges or being emitted from the edges is substantially the same. Therefore, it is rare for edge 40 to exert an influence on the uniformity of the brightness of the light radiated from the illumination device. For this reason, even if reflecting member 44 is omitted, it is still possible to obtain uniform brightness. However, it is difficult to maintain good uniformity if the gap between the edge and the fluorescent light becomes large. In considering the fluorescent light and interference, it is found to be desirable to make the length of one of the diamond-shaped sides, as noted above, to be within the range of 0.6 to 1.0 times the smallest radius of curvature of bent portion 22a of fluorescent light 22.

FIGS. 10C and 10D show other examples of the shape of edge 40 when the manufacturing process of light guide plate 21 is considered. In the case of injection formation of light guide plate 21 and from the aspect of type processing, a "fan-

P1933.D2

shape" as shown in FIG. 10C can be used. In the case of machining light guide plate 21 to form edge 40, an "opposite fan-shape" is possible. Of course, other shapes are also possible.

5 FIG. 11 shows diffusion pattern 50 for emitting light introduced to light guide plate 21 from bent fluorescent light 22 to the liquid crystal display panel through upper surface 21a of light guide plate 21. Although in this embodiment diffusion pattern 50 is printed on pattern sheet 42, it is also possible to print the pattern directly on lower surface 21b of light guide plate 21. It also is, of course, possible to draw diffusion pattern 50 on the lower surface of light guide plate 21 by
10 using such methods as etching. Although line patterns and dot patterns are most commonly used, other patterns, as well as increasing or decreasing the pattern area density at different places are also possible.

15 In the case of the dot diffusion pattern, a method of increasing or decreasing the area of each dot or a method of increasing or decreasing the dot density is possible for adjusting the area density of the pattern. FIG. 11 shows an example of a pattern where the area of the dots are increased or decreased. The dot areas are small near edges 41c and 41d where fluorescent light 22 is positioned and these areas gradually increase as they move towards the opposing edges 41a and 41b. The dots near edge 40 which is near bent portion 22a of fluorescent light 22 have
20 the smallest areas and the dots on the corner opposite to this between edge 41a and 41b have the largest areas.

25 The density distribution $S(x,y)$ of this diffusion pattern is described below. Here, x and y are coordinates along edges 41c and 41d of fluorescent light 22, and a coordinate axis is used that increases in the direction away from fluorescent light 22. For some small areas, the density distribution of a diffusion pattern is assumed in advance to be $S_{x_1y_1}$. The intensity $l_{1,1}$ of the light diffused by the diffusion pattern of density distribution $S_{x_1y_1}$ as it relates to the light incident from the x direction with an intensity of L_x is represented by the following equation, where k
30 is a reflection coefficient.

$$l_{1,1} = L_x \times S_{x_1y_1} \times k \quad (1)$$

The intensity of the light diffused at the next small area in the x direction, $l_{2,1}$, is represented by the following equation.

$$l_{2,1} = (L_x - l_{1,1}) \times S_{x_2y_1} \times k \quad (2)$$

35 Similarly, the intensity $l_{1,j}$ of the light diffused by the diffusion pattern of density distribution $S_{x_1y_j}$ and emitted by each small area as it relates to the light incident from the y direction with an intensity of L_y is represented by the following equation.

$$l_{1,j} = (L_x - \sum_{a=1}^{j-1} l_{a,j}) \times S_{x_1y_j} \times k + (L_y - \sum_{b=1}^{j-1} l_{1,b}) \times S_{x_1y_j} \times k \quad (3)$$

P1933.D2

The average intensity radiated, l_{ave} , is represented by the following equation, where n is the number of the small areas in the x axis direction and m is the number of the small areas in the y axis direction.

$$l_{ave} = \sum_{i=1}^n \sum_{j=1}^m l_{i,j} / (n \times m) \quad (4)$$

5 Keeping the intensity of the light diffused by the diffusion pattern in a fixed range is necessary in order to make the brightness of illumination device 20 uniform. Consequently, the density distribution S_{x,y_j} of the diffusion pattern assumed in advance must be compensated and is represented by the following equation.

10
$$S^1_{x,y_j} = S_{x,y_j} \times l_{ave} / \sum l_{i,j} \quad (5)$$

15 Just as above, the intensity of the light diffused at each small area using the compensated density distribution S^1_{x,y_j} of the diffusion pattern is recalculated. If this intensity can be kept within the permitted range, a diffusion pattern with proper brightness uniformity will be generated. If, despite using the once compensated density distribution S^1_{x,y_j} , the intensity of the light is not kept within the fixed range, repeat the compensation with the above technique.

20 In this way, when the diffusion pattern is generated, based on the intensity of the incident light in both the x and y directions, the intensity of the light emitted by diffusion at each coordinate, or each small area, is calculated for all directions. Along with finding the light intensity emitted at each small area that composes the intensity, the average light intensity is found and the density distribution of the diffusion pattern is compensated so that variations of the light intensity emitted from each small area will be kept within the average light intensity and fixed range.

25 Further, it is desirable to compensate for the intensity of the light reflected from edge reflective tape 28 which is placed on edges 41a and 41b. For the intensity of the light reflected from edge 41a and 41b by edge reflective tape, it is appropriate to add the intensity of the light that is diffused and emitted to the calculation of $l_{i,j}$, the intensity of light emitted from each small area.

30 The following is an equation for L_x , the intensity of light reflected from edge 41a in the x direction.

$$L_x' = (L_x - \sum_{i=1}^n l_{i,j}) \times \eta \quad (6)$$

35 In this equation, η is the reflection coefficient of the edge reflective tape. A number, for example, such as 0.5 may be used. Consequently, by performing a further calculation to that discussed above, a density distribution of the diffusion pattern compensated for the edge reflection can be obtained for the light source of the intensity incident from coordinate x_a in the x direction. And, by using diffusion

P1933.D2

pattern 50 which follows this density distribution, illumination with a high uniform brightness can be achieved through the light guide plate.

FIGS. 12A and 12B show an example of increasing and decreasing the thickness of the light guide plate instead of forming a diffusion pattern that differs in density on the light guide plate. In this example of light guide plate 29, diffusion pattern 51, which has a fixed density distribution, is printed on lower surface 29b. The cross section of light guide plate 29 is formed such that it is inversely proportional to the density distribution of the diffusion pattern discussed above. In other words, edges 41c and 41d of light guide plate 29 are thick and the thickness become gradually thinner in the direction of edges 41a and 41b. When the thickness of light guide plate 29 is thinned in inverse proportion to the density distribution of the diffusion pattern as above, the density of the light, which is illuminated by the diffusion pattern of uniform density formed on lower surface 29b, increases. Consequently, the intensity of the light diffused by diffusion pattern and emitted from upper surface 29a is averaged the same as the light emitted by the diffusion pattern with the density distribution as described above. A light guide plate such as light guide plate 29 shown in FIG. 12 can, therefore, also achieve illumination with high uniform brightness.

Illumination device 20, as explained above, uses as its light source one long fluorescent light that is bent in an L-shape and can be installed at the light guide plate which has a corner removed. Consequently, the effective overall length of the fluorescent light can be extended and the gross luminous energy increased without increasing the number of the driver circuits used for turning on the fluorescent light. Also, when there are a plurality of fluorescent lights, the necessity to adjust such things as the driver circuits so that the brightness of the plurality of fluorescent lights are in agreement does not exist. Further, because the light conversion efficiency can be increased, power consumption can be reduced. In regard to the output of the driver circuit for turning on the fluorescent light, although it is necessary to increase the output ability because the overall length of the fluorescent light is extended, when compared with the case of turning on two fluorescent lights, the output of the driver circuit is still low.

Illumination device 20 can be used in various ways as a surface-type illuminant in addition to the liquid crystal display discussed above. When used to provide backlight in a liquid crystal display panel, the fluorescent light can be arranged in a place opposite to the liquid crystal driver IC because an L-shape fluorescent light is used. For this reason, the effects of heat from the illuminant to the driver IC can be kept to a minimum and a stable display can be obtained. Also, as the illuminant and driver IC have no positional interferences, the size of the liquid crystal display can be reduced. Further, the power consumption of the

P1933.D2

illumination system is low, the heating power per unit length is low as the illuminating portion is long, and the temperature rise of the liquid crystal panel can, to a great extent, be kept down. Consequently, when high brightness necessary for color displays is shown, color and brightness irregularities of the liquid crystal panel can be prevented and a good quality, vivid color display can be obtained.

Further, to simplify the manufacturing process and obtain a display with uniform illumination and good display quality for the illumination device and the liquid crystal display, many things such as the shape of the reflector and the generation method of the diffusion pattern are improved and a low-cost liquid crystal display with good display quality is provided.

In the above, only one corner from edge 40 of the light guide plate is removed. However, it is also possible to remove all four corners. If all four corners of the same shape are removed, the directionality of the light guide plate becomes unimportant at the time of assembly and the manufacturing process can be further simplified.

EMBODIMENT 2

FIG. 13 shows a liquid crystal display using an illumination device 60, which differs from that described above, and liquid crystal panel 10 installed on illumination device 60. The drawings and descriptions which are substantially similar to the embodiment shown in FIG. 1 are eliminated. Also, the same reference numbers for liquid crystal display panel 10 and other parts that are in common with the first embodiment will be used and the descriptions will be eliminated.

Illumination device 60 uses a U-shaped fluorescent light 62 as a light source. Fluorescent light 62 is positioned next to edges 41a, 41c and 41d on light guide plate 61 of illumination device 60. Illumination device 60 is enclosed within frames 38 and 39, which are upper and lower sections, respectively. Upper frame 38 acts as a spacer to secure the gap between liquid crystal display panel 10 and illumination device 60.

The construction of illumination device 60 of this embodiment will be explained with reference to FIGS. 14 and 15. Within the U-shaped lower frame 39 of illumination device 60 are enclosed the following in the order from bottom to top, reflecting sheet 25, light guide plate 61, diffusion sheet 26, and prism sheet 27. U-shaped fluorescent light 62 is installed next to three of the edges of light guide plate 61, 41a, 41c, and 41d. The remaining edge 41b is attached with edge reflective tape 28. On top of lower frame 39, which encloses all of these, is the flat, U-shaped upper frame 38.

P1933.D2

5 The mirror surface of the hyperbolic curve section of the inner surface 63 of lower frame 39 is formed by silver deposition or the like. The lower surface 64 of upper frame 38 is also silver deposited and mirrorized. The inner surface 63 and lower surface 64 of frames 39 and 38, respectively, function as a reflector. Thus, the reflector and frame described in the previous embodiment are integrated into one part. Consequently, the problems associated with assembling illumination device 60 is further reduced.

10 The explanation of the functions of reflection sheet 25, diffusion sheet 26, and prism 27 will be omitted as they are the same as that explained in the earlier embodiment. In this example, the pattern sheet is omitted because the diffusion sheet 52 is printed on lower surface 61b of light guide plate 61. The two corners are removed from edges 40a and 40b of light guide plate 61 in order to install U-shaped fluorescent light 62 with an appropriate gap 42 from the light guide plate, as explained in the embodiment above. FIG. 16 shows the relationship between fluorescent light 62 and light guide plate 61. The corner of edge 40b, which is between edges 41c and 41d, and the corner of edge 40a, which is between edges 41a and 41d, are removed so that they do not stick out. In this way, fluorescent light 62 can be installed with fixed gap 42 from edges 41, and the incident efficiency towards light guide plate 61 can be maintained at a high level. Also, damage to fluorescent light 62 caused by thermal expansion, shock etc. can be prevented. The shape of the removed corner, in this example, is a triangle with two sides of approximately equal length. However, as explained earlier, it is also possible to use other shapes.

15
20
25
30
35
FIG. 17 shows diffusion pattern 52, which is printed on lower side 61b of light guide plate 61. Diffusion pattern 52 is formed using the density distribution obtained by the generation method discussed above. In this embodiment, because in addition to the light source from edge 41c there is a light source from edge 41a, the area density of the diffusion pattern on this side is low and the area density of the diffusion pattern in the middle of lower surface 61b is high. Also, the area density of the diffusion pattern along edge 41d is low, and the area density of the diffusion pattern opposite to this side near edge 41b is high. Through diffusion pattern 52, the light introduced to light guide plate 61 is diffused and a uniform light is emitted from upper surface 61a of light guide plate 61 towards the liquid crystal display panel.

FIG. 18 shows the temperature distribution on liquid crystal display panel 10 of this embodiment. From this graph it can be seen that the temperature rise of that portion of the panel directly opposite to the fluorescent light increases only about 10 degrees above the regular temperature. As shown in FIG. 22, this is a significant reduction as compared with the temperature rise in a conventional illumination device. Because of the very small difference between the temperature

P1933.D2

of the central portion of the liquid crystal display panel and the temperature of the edge portions near the light source and the resulting flat temperature distribution, there is a very small amount of image and brightness irregularities that appear on the liquid crystal display panel. Consequently, a good quality image can be
5 obtained. Therefore, illumination device 60 is an illumination device that can irradiate a light of high brightness for color displays and can prevent a temperature rise on the liquid crystal display panel. Because of the use of a long light source bent in a U-shape, the amount of heating per unit length can be reduced and, still further, a reduction in power consumption can be achieved.

10 In the present embodiment of the liquid crystal display device, as shown in FIG. 13, driver IC 13 is arranged on one of the sides of the U-shaped fluorescent light. However, because the rise in temperature of fluorescent light 62 is small, thermal expansion towards driver IC is small and problems such as fluctuations in the threshold value can be controlled. Consequently, by using the liquid crystal display of this embodiment, a vivid and stable color image with high brightness can be obtained and low power consumption can be achieved. As only one driver circuit is necessary to turn on the fluorescent light, devices that use liquid crystal displays, such as televisions and personal computers, can be miniaturized. Because the discharge length is increased, the driver circuit output must be improved to turn on
15 the U-shaped fluorescent light. However, as compared to turning on three separate fluorescent lights, the increase in the output of the driver circuit is small.

20 FIG. 19 shows an example of two approximately L-shaped fluorescent lights 72a and 72b installed on light guide plate 71. FIG. 20 shows three approximately L-shaped fluorescent lights 82a, 82b, and 82c installed on hexagonal light guide plate
25 81. The corners are removed from the edge portions 40 of both light guide plates 71 and 81 so that there is no interference with fluorescent lights 72 and 82 and these lights can be properly positioned. Structures discussed in the above embodiments, such as those of the reflectors, can also be used here.

30 Various shapes of surface-type illumination systems can be formed using a bent, cylindrical illuminant. With these illumination devices, a uniform illumination device with high brightness can be obtained that has low power consumption. Also, a high quality color display can be obtained when a color liquid crystal display panel is used.

35 The surface-type illumination device of the invention is suitable for providing backlight in liquid crystal display devices that use a liquid crystal display panel or for using as other flat, surface-type illumination devices. Because liquid crystal display devices using this illumination device can display vivid color with low power consumption, it can be used as a display in notebook PCs and other information

P1933.D2

processing devices as well as in devices such as liquid crystal TVs, video cameras, and other image processing devices.

5 While the invention has been described in conjunction with several specific embodiments, it is evident to those skilled in the art that many further alternatives, modifications and variations will be apparent in light of the foregoing description. Thus, the invention described herein is intended to embrace all such alternatives, modifications, applications and variations as may fall within the spirit and scope of the appended claims.

66230 " 291360

Attorney Docket No.: P1933b

DECLARATION AND POWER OF ATTORNEY FOR PATENT APPLICATION

Original Design National Stage of PCT CIP

As a below named inventor, I hereby declare that:

My residence, post office address and citizenship are as stated below, next to my name,

I believe I am the original, first and sole inventor (if only one name is listed below) or an original, first and joint inventor (if plural names are listed below) of the subject matter which is claimed and for which a patent is sought on the invention entitled:

SURFACE-TYPE ILLUMINATION DEVICE AND LIQUID CRYSTAL DISPLAY

as described and claimed in the specification which

is attached hereto.

was filed on March 11, 1994 as Application Serial No. 08/204,374 or Express Mail No. _____ as Serial No. not yet known and was amended on (if applicable) _____.

was set forth in PCT International Application No. PCT/JP93/00965 filed on July 13, 1993 and as amended under PCT Article 19 on _____ (if any).

I have reviewed and understand the contents of the above-identified specification, including the claims, as amended by any amendment referred to above.

I acknowledge the duty to disclose to the U. S. Patent and Trademark Office all information known to me to be material to patentability as defined in Title 37, Code of Federal Regulations, Section 1.56.

In compliance with this duty there is attached an Information Disclosure Statement. 37 CFR 1.97.

I hereby claim foreign priority benefits under Title 35, United States Code, Section 119, of any foreign application(s) for patent or inventor's certificate or any PCT international application(s) listed below, and filed by me/us on the same subject matter having a filing date within one year before that of the application(s) on which priority is claimed.

No such Applications have been filed.

Such Applications have been filed as follows:

Prior Foreign Application(s)			Priority Claimed Under 35 U.S.C. 119	
<u>4/184976</u> (Application Number)	<u>Japan</u> (Country)	<u>13 July 92</u> (Day/Month/Year Filed)	<u>X</u> Yes	<u> </u> No
<u>5/111852</u> (Application Number)	<u>Japan</u> (Country)	<u>13 May 93</u> (Day/Month/Year Filed)	<u>X</u> Yes	<u> </u> No
<u> </u> (Application Number)	<u> </u> (Country)	<u> </u> (Day/Month/Year Filed)	<u> </u> Yes	<u> </u> No
<u> </u> (Application Number)	<u> </u> (Country)	<u> </u> (Day/Month/Year Filed)	<u> </u> Yes	<u> </u> No

Attorney Docket No.: P1933b

I hereby claim the benefit under Title 35, United States Code, §120 of any United States application(s) listed below and, insofar as the subject matter of each of the claims of this application is not disclosed in the prior United States application in the manner provided by the first paragraph of Title 35, United States Code, §112, I acknowledge the duty to disclose to the Office all information known to me to be material to patentability as defined in Title 37, Code of Federal Regulations, §1.56 which occurred between the filing date of the prior application(s) and the national or PCT international filing date of this application:

No such Applications have been filed.

Such Applications have been filed as follows:

(Application Serial No.)	(Filing Date)	(Status) (patented, pending, abandoned)
(Application Serial No.)	(Filing Date)	(Status) (patented, pending, abandoned)

I hereby appoint W. Douglas Carothers, Jr., Reg. No. 22,024; Eric B. Janofsky, Reg. No. 30,759; and Harold T. Tsiang, Reg. No. 35,721, my attorneys with full power of substitution and revocation, to prosecute this application and to transact all business in the Patent and Trademark Office connected herewith. Send all correspondence to: W. Douglas Carothers, Jr.; General Patent Counsel; Legal Office; S-MOS Systems, Inc.; 2460 North First St.; San Jose, CA 95131-1002 telephone (408) 922-0200.

I hereby declare that I have reviewed and understand the contents of this Declaration, and that all statements made herein of my own knowledge are true and that all statements made on information and belief are believed to be true; and further that these statements were made with the knowledge that willful false statements and the like so made are punishable by fine or imprisonment, or both, under Section 1001 of Title 18 of the United States Code and that such willful false statements may jeopardize the validity of the application or any patent issued thereon.

Full Name of Sole/First Inventor: Tatsuaki Funamoto
Inventor's Signature: <i>Tatsuaki Funamoto</i> Date: <i>194 Apr. 8</i>
Residence: 3-5 Owa 3-chome, Suwa-shi, Nagano-ken 392, Japan, c/o Seiko Epson Corporation
Citizenship: Japan
Post Office Address: Same as above.
Full Name of Second/Joint Inventor: Toru Yagasaki
Inventor's Signature: <i>Toru Yagasaki</i> Date: <i>194 Apr. 27</i>
Residence: 3-5 Owa 3-chome, Suwa-shi, Nagano-ken 392, Japan, c/o Seiko Epson Corporation
Citizenship: Japan
Post Office Address: Same as above.

Attorney Docket No.: P1933b

Full Name of Third/Joint Inventor: Fumiaki Akahane	
Inventor's Signature: <i>Fumiaki Akahane</i>	Date <i>'94 Apr. 8</i>
Residence: 3-5 Owa 3-chome, Suwa-shi, Nagano-ken 392, Japan, c/o Seiko Epson Corporation	
Citizenship: Japan	
Post Office Address: Same as above.	

2025 APR 10 10 10 AM

4/9/65

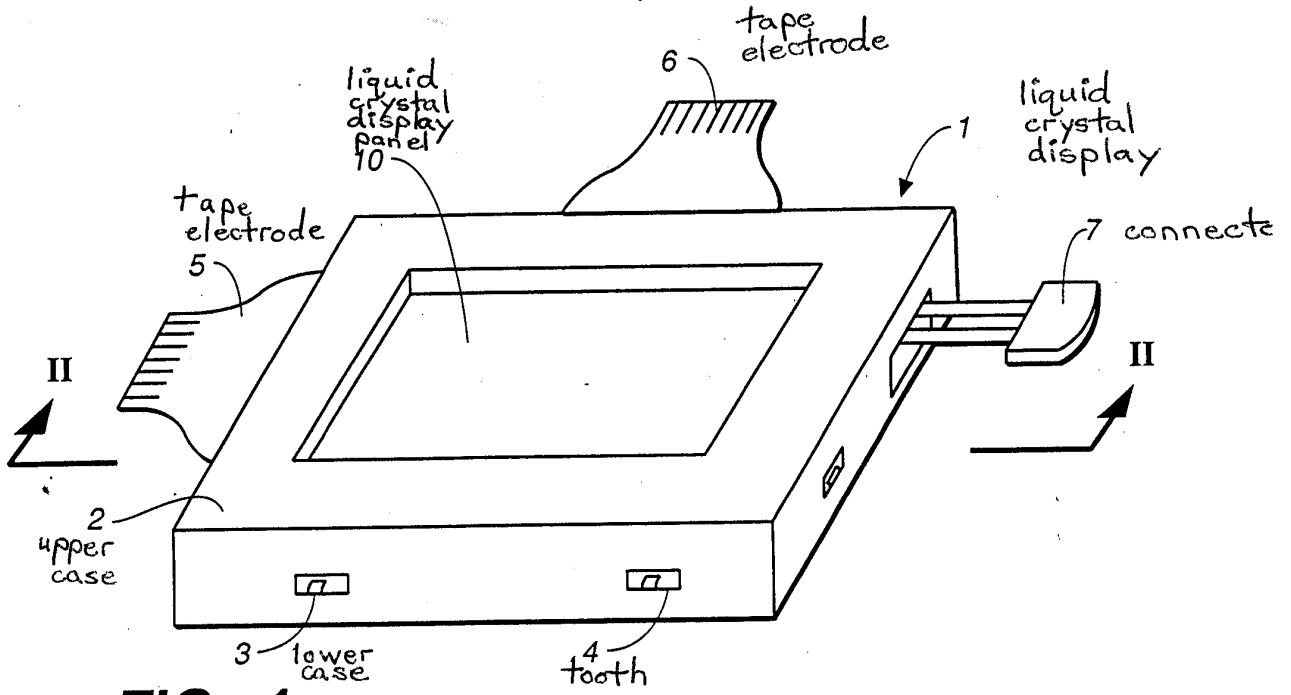

FIG. 1

A Sketch of a Liquid Crystal Display using the Surface-Type Illumination Device in accordance with the First Embodiment of the Invention

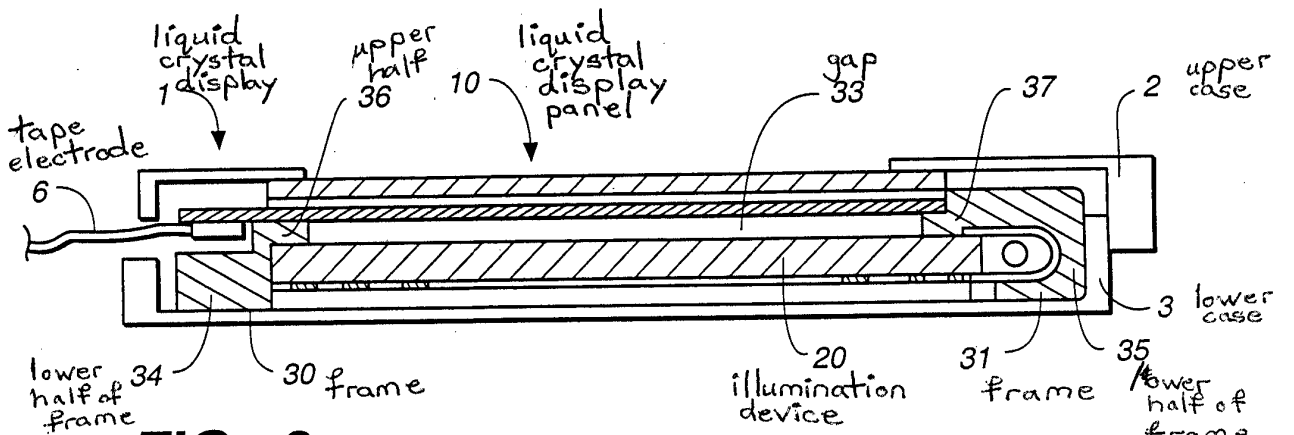
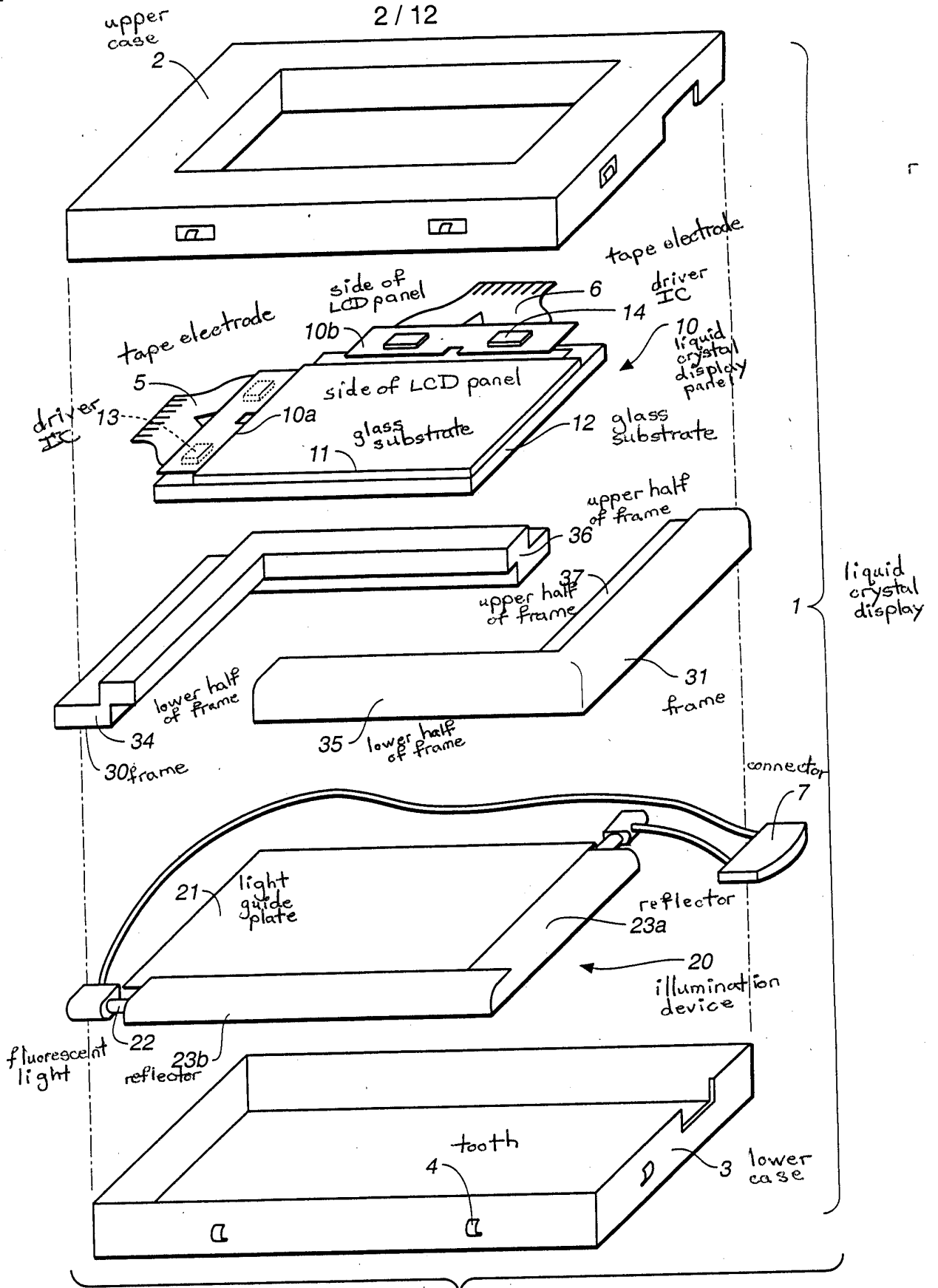

FIG. 2

A Cross-Sectional View of Fig. 1 showing the Structure of the Liquid Crystal Display

+

2 / 12



66250-482500

FIG. 3

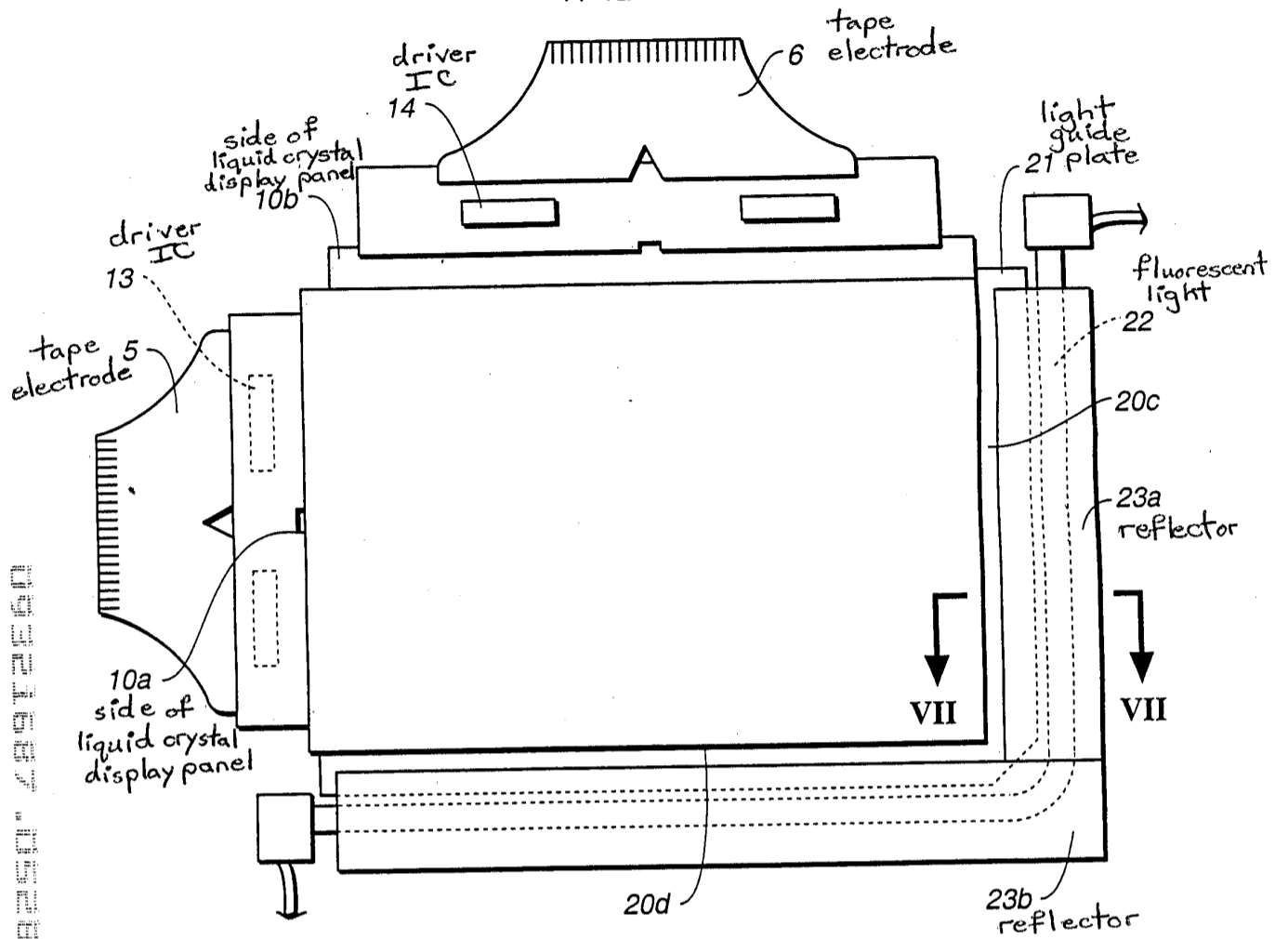

FIG. 5

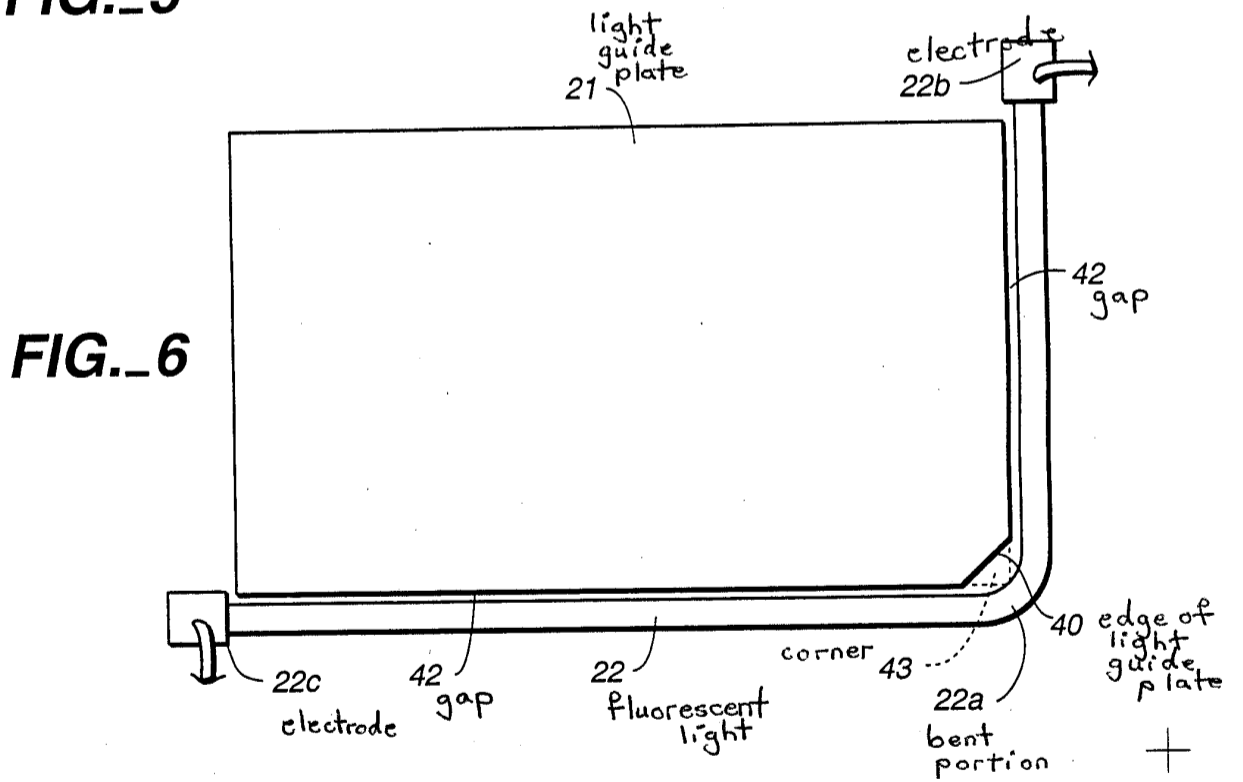

FIG. 6

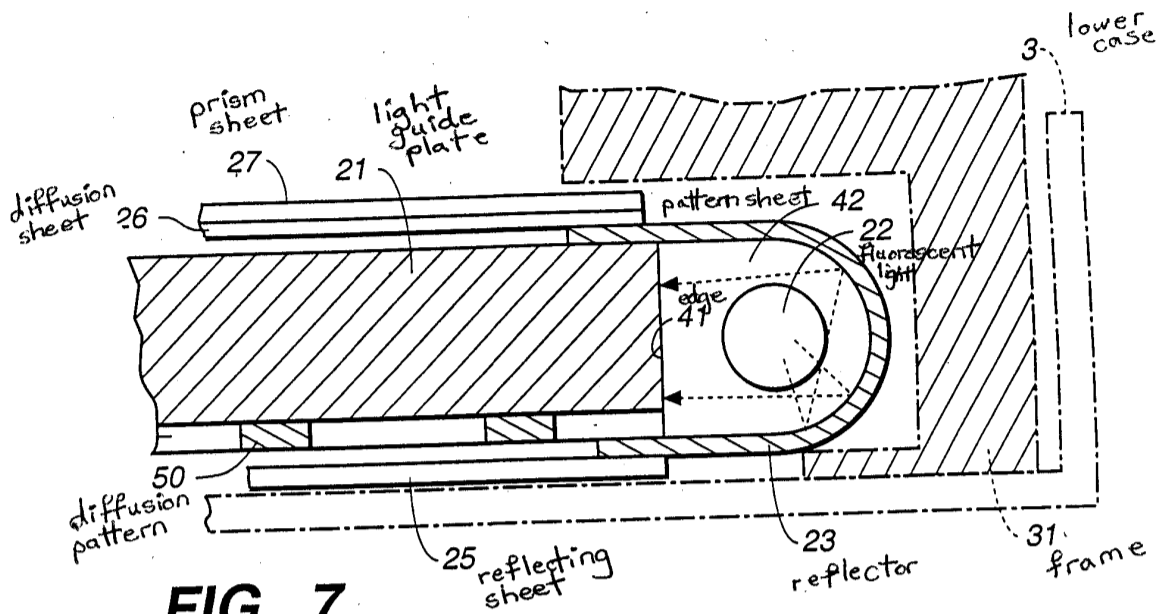

FIG. 7

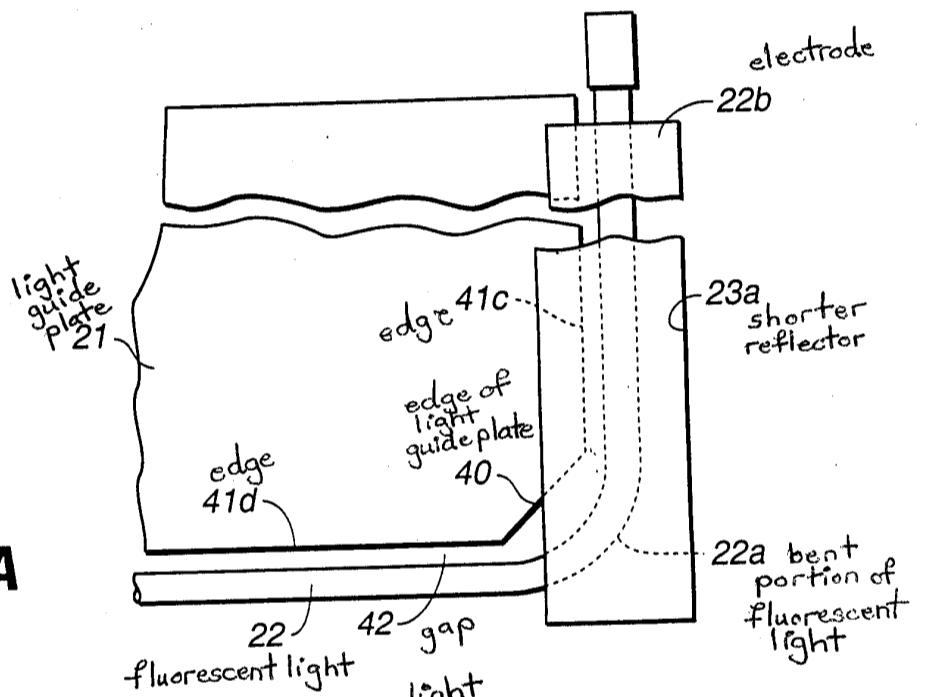

FIG. 8A

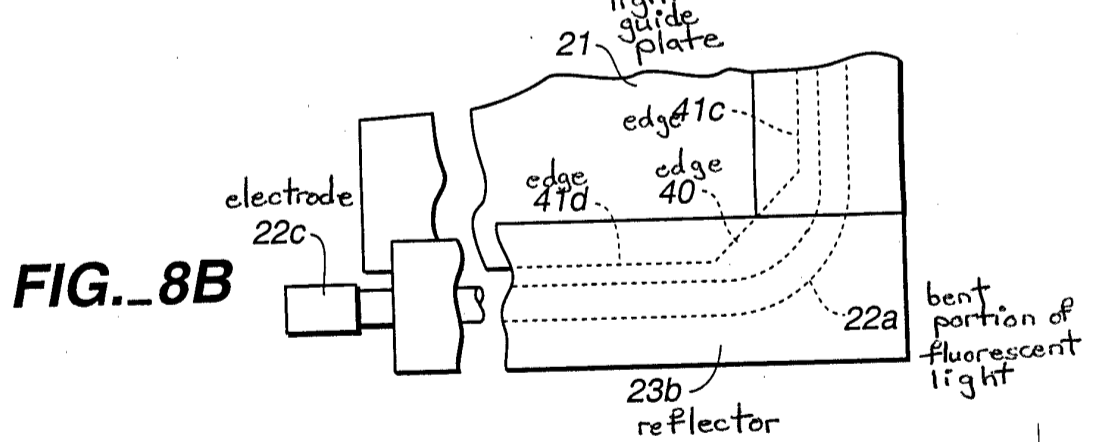

FIG. 8B

09321687.052899

+

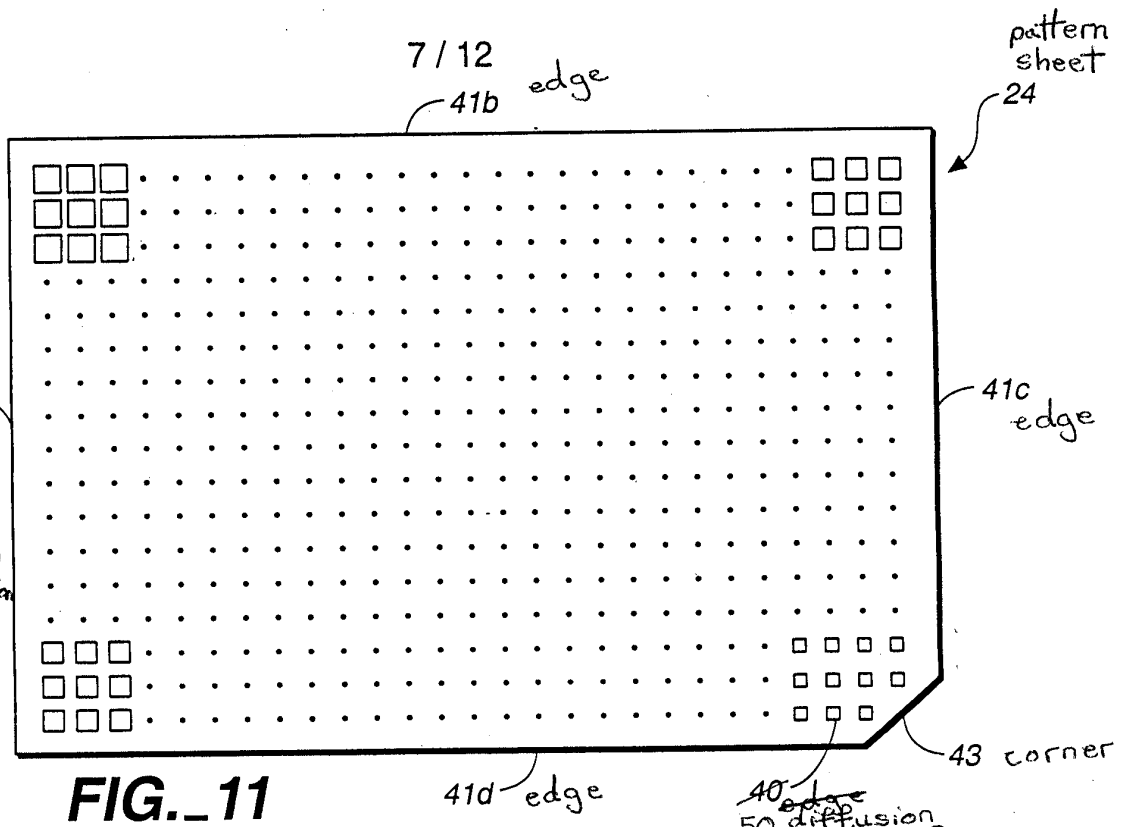

FIG. 11

An Explanatory Drawing showing the Diffusion Pattern formed on the Diffusion sheet which sticks to the Light Guide plate

LGE_000921

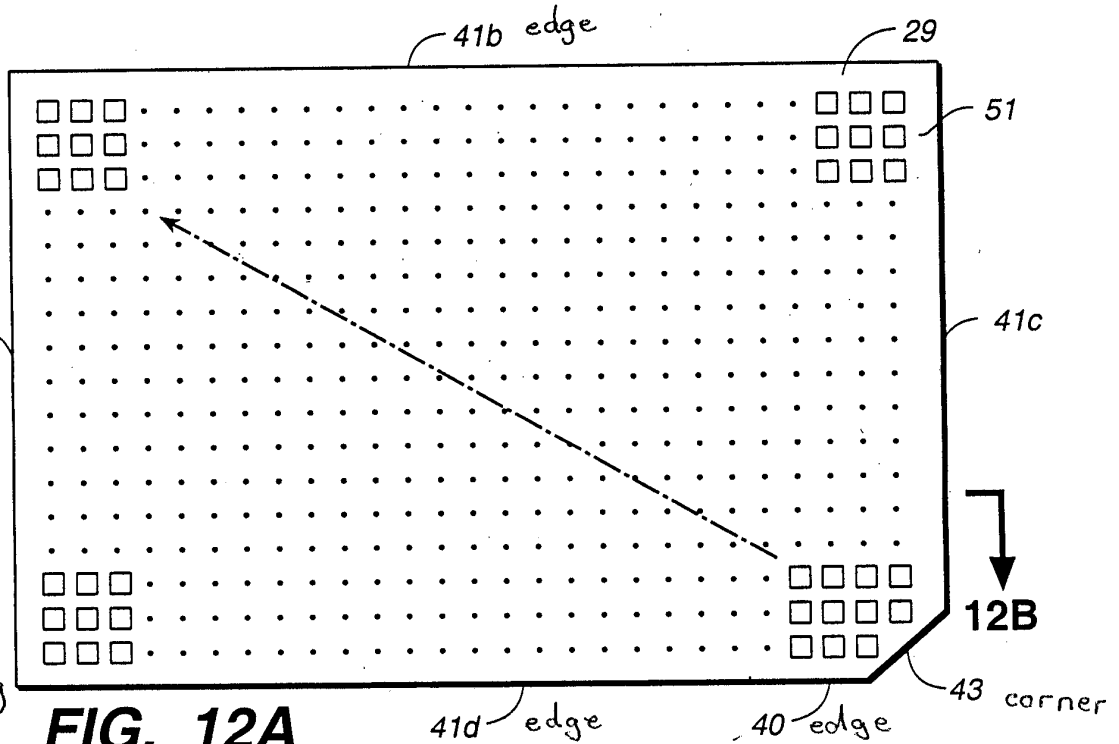

FIG. 12A

A Plan View showing Light Guide Plate whose Thickness has been changed

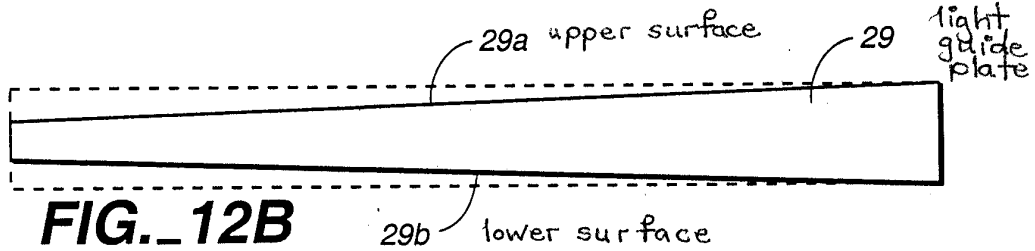

FIG. 12B

A Cross Sectional View showing a Light Guide Plate whose Thickness has been changed

+

9/12

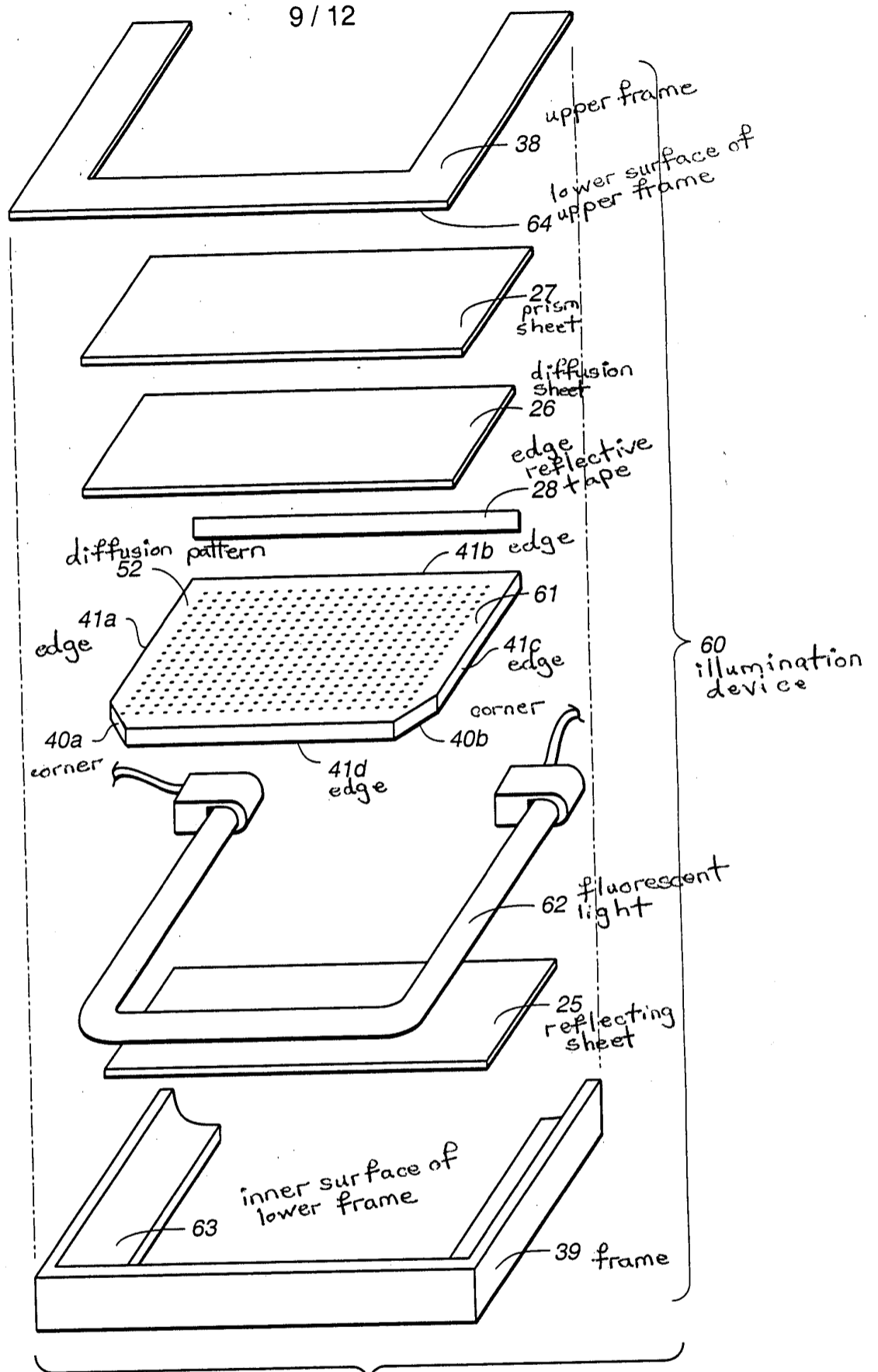

FIG. 15

0932167 J52899

+

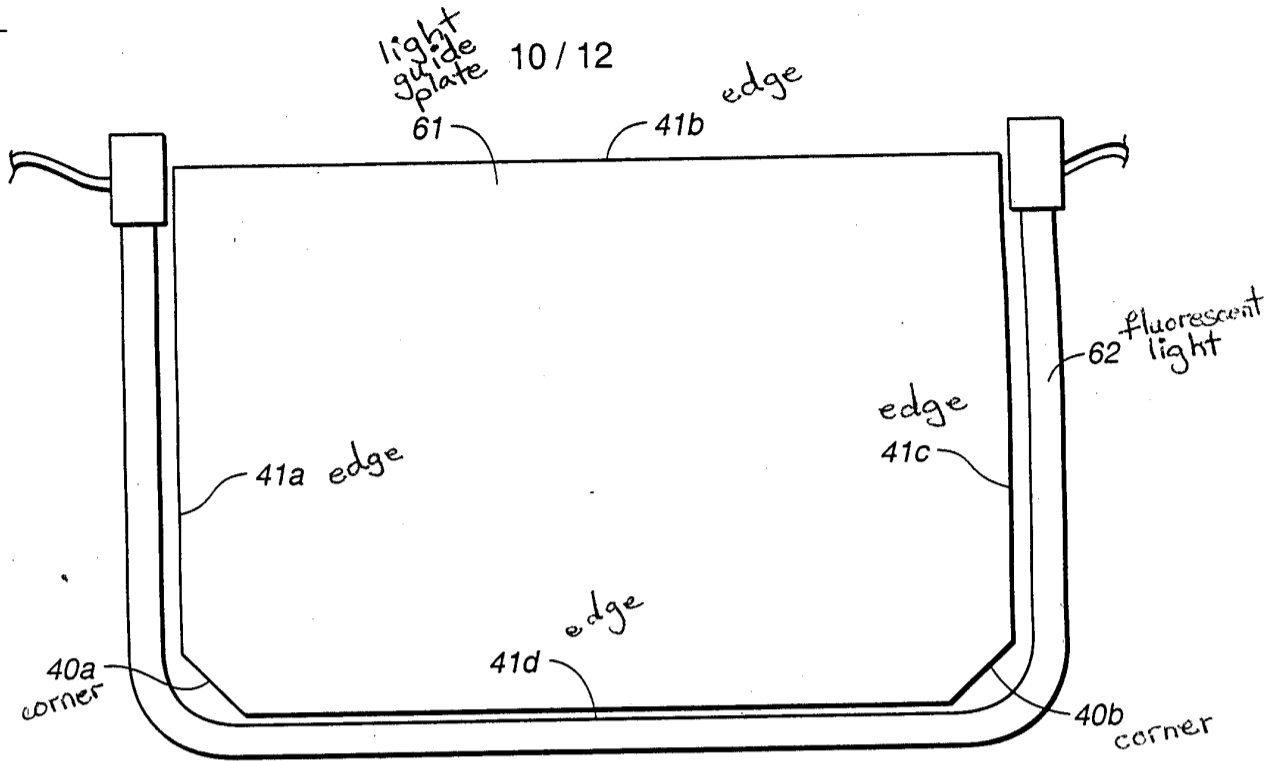

FIG. 16

092250 2812560

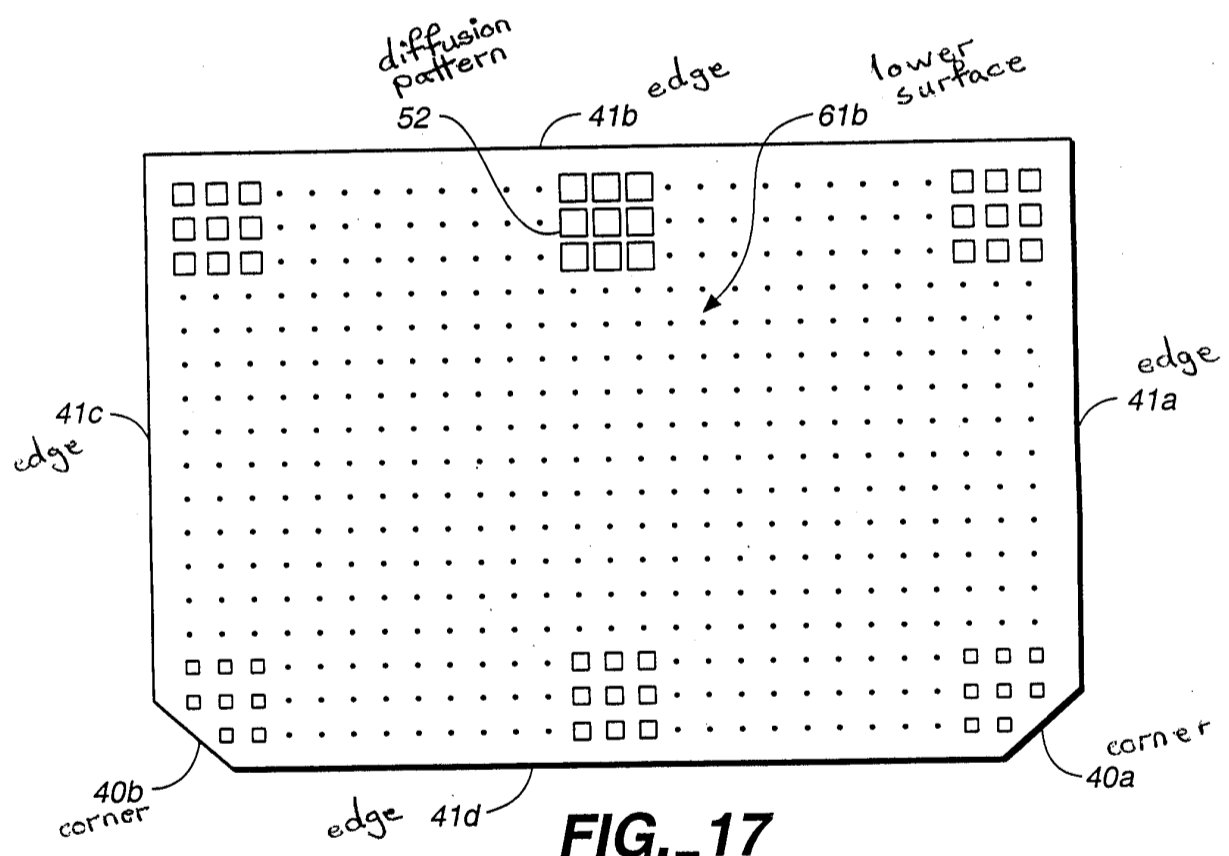
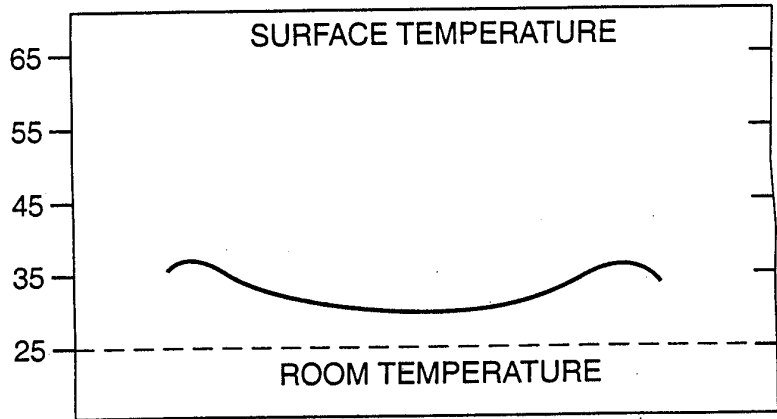

FIG. 17

+

A Graph showing the Surface Temperature of the Liquid Crystal Display Panel shown in Fig. 13

FIG. 18



POSITION DIRECTLY OVER THE LIGHT SOURCE
CENTRAL PORTION OF THE IMAGE
POSITION DIRECTLY OVER THE LIGHT SOURCE

An Explanatory Drawing showing another Relationship of the Light Guide Plate and the Fluorescent Light

FIG. 19

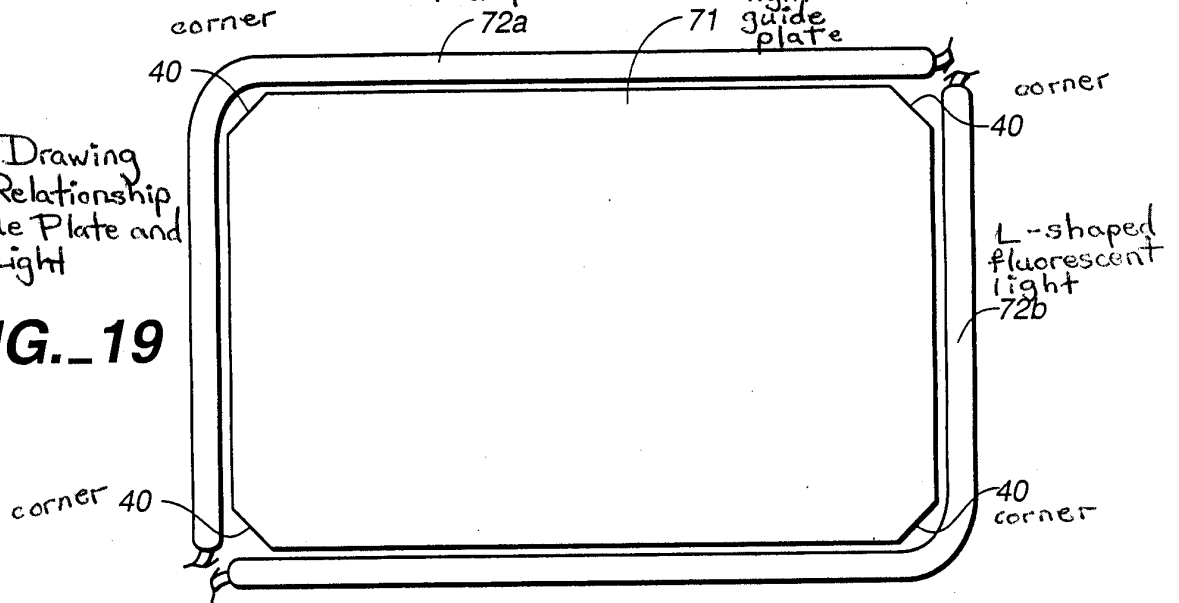
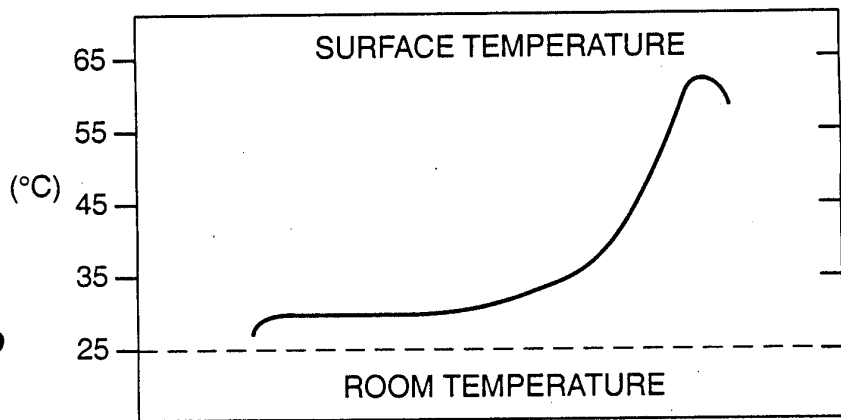

FIG. 22



END PORTION OF THE IMAGE
CENTRAL PORTION OF THE IMAGE
POSITION DIRECTLY OVER THE LAMP LIGHT SOURCE

A Graph showing the Surface Temperature of a Liquid Crystal Display Panel using a Surface-Type Illumination Device similar to the One shown in Fig. 21

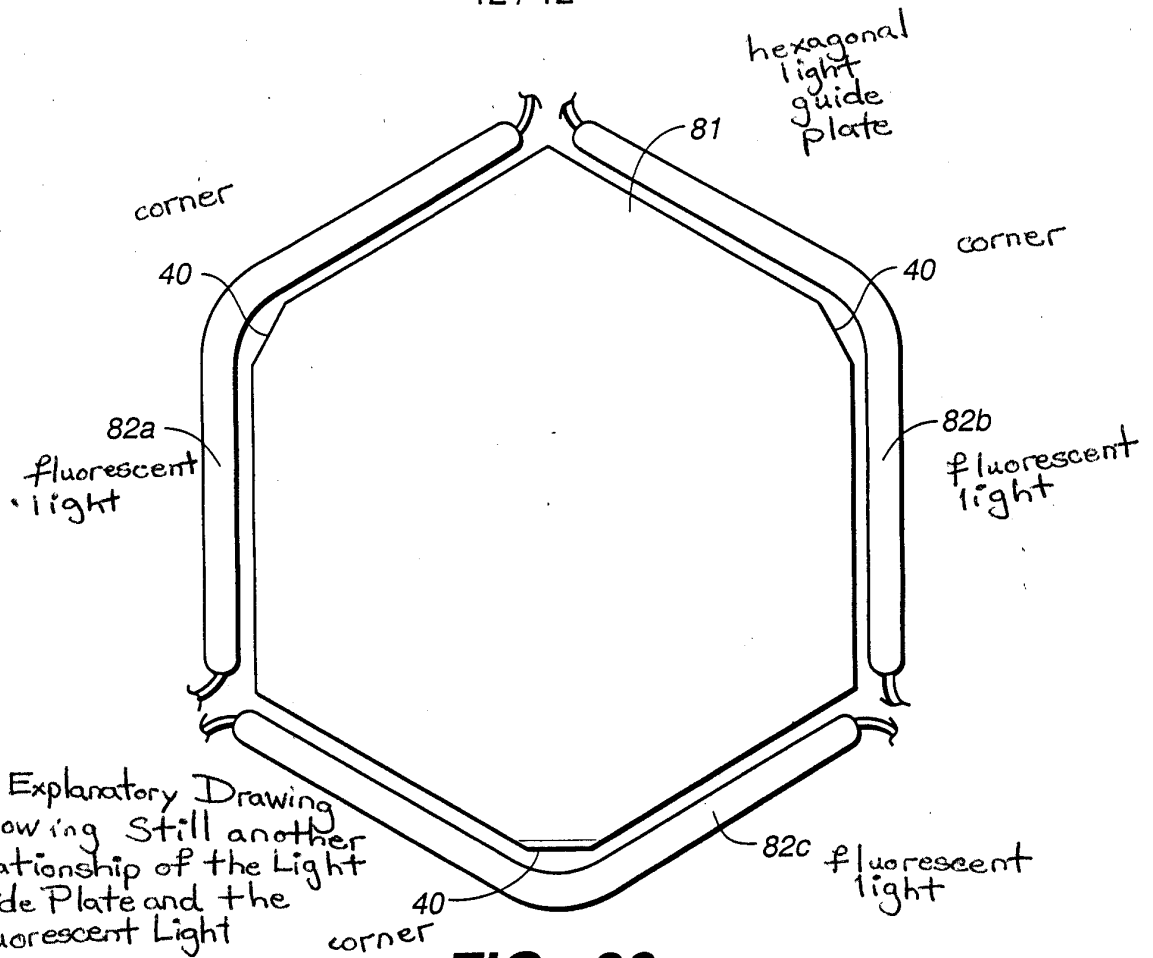

FIG. 20

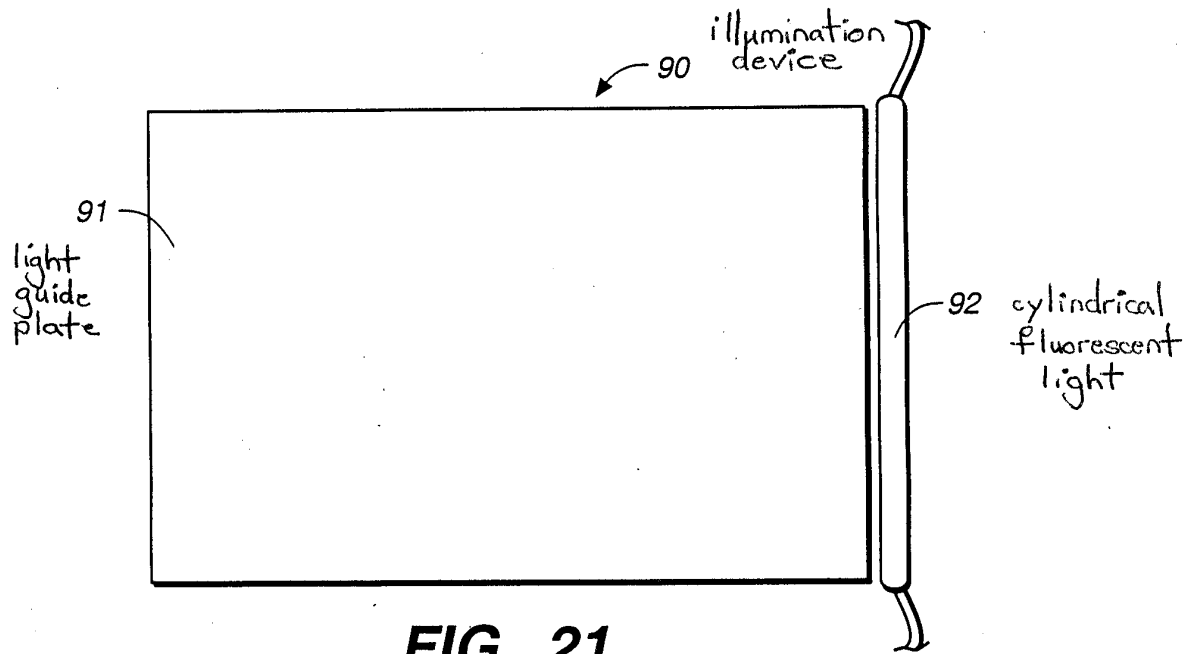

FIG. 21

PATENT APPLICATION FEE DETERMINATION RECORD

Effective November 10, 1998

Application or Docket Number

09/321687

CLAIMS AS FILED - PART I

FOR	(Column 1) NUMBER FILED	(Column 2) NUMBER EXTRA
BASIC FEE		
TOTAL CLAIMS	1	minus 20 = *
INDEPENDENT CLAIMS		minus 3 = *
MULTIPLE DEPENDENT CLAIM PRESENT		

* If the difference in column 1 is less than zero, enter "0" in column 2

SMALL ENTITY TYPE

OR OTHER THAN SMALL ENTITY

RATE	FEE	OR	RATE	FEE
	380.00			760.00
X\$ 9=			X\$18=	
X39=			X78=	
+130=			+260=	
TOTAL			TOTAL	760

CLAIMS AS AMENDED - PART II

AMENDMENT A	(Column 1)	(Column 2)	(Column 3)	PRESENT EXTRA
	CLAIMS REMAINING AFTER AMENDMENT	HIGHEST NUMBER PREVIOUSLY PAID FOR		
Total	* 18	Minus	** 20	= -
Independent	* 1	Minus	*** 3	= -
FIRST PRESENTATION OF MULTIPLE DEPENDENT CLAIM				

SMALL ENTITY

OR OTHER THAN SMALL ENTITY

RATE	ADDITIONAL FEE	OR	RATE	ADDITIONAL FEE
X\$ 9=			X\$18=	
X39=			X78=	
+130=			+260=	
TOTAL ADDIT. FEE			TOTAL ADDIT. FEE	

AMENDMENT B	(Column 1)	(Column 2)	(Column 3)	PRESENT EXTRA
	CLAIMS REMAINING AFTER AMENDMENT	HIGHEST NUMBER PREVIOUSLY PAID FOR		
Total	*	Minus	**	=
Independent	*	Minus	***	=
FIRST PRESENTATION OF MULTIPLE DEPENDENT CLAIM				

RATE

RATE

RATE	ADDITIONAL FEE	OR	RATE	ADDITIONAL FEE
X\$ 9=			X\$18=	
X39=			X78=	
+130=			+260=	
TOTAL ADDIT. FEE			TOTAL ADDIT. FEE	

AMENDMENT C	(Column 1)	(Column 2)	(Column 3)	PRESENT EXTRA
	CLAIMS REMAINING AFTER AMENDMENT	HIGHEST NUMBER PREVIOUSLY PAID FOR		
Total	*	Minus	**	=
Independent	*	Minus	***	=
FIRST PRESENTATION OF MULTIPLE DEPENDENT CLAIM				

RATE

RATE

RATE	ADDITIONAL FEE	OR	RATE	ADDITIONAL FEE
X\$ 9=			X\$18=	
X39=			X78=	
+130=			+260=	
TOTAL ADDIT. FEE			TOTAL ADDIT. FEE	

* If the entry in column 1 is less than the entry in column 2, write "0" in column 3.
 ** If the "Highest Number Previously Paid For" IN THIS SPACE is less than 20, enter "20."
 *** If the "Highest Number Previously Paid For" IN THIS SPACE is less than 3, enter "3."
 The "Highest Number Previously Paid For" (Total or Independent) is the highest number found in the appropriate box in column 1.

P1933.D2

PATENT

Gp 287 #2/IPS
Atad
8/19/99

IN THE UNITED STATES PATENT AND TRADEMARK OFFICE

Inventors: Tatsuaki Funamoto, et al.

Group Art Unit: Not Yet Assigned

Serial No.: 09/321,687

Examiner: Not Yet Assigned

Filed: May 28, 1999

Title: Surface-Type Illumination Device And Liquid Crystal Display



CERTIFICATE OF MAILING

I hereby certify that this correspondence, and the documents attached hereto, are being deposited with the United States Postal Service as First Class mail in an envelope addressed to Assistant Commissioner for Patents, Washington, D.C. 20231 on this date.

Date: June 30, 1999

Shellie Bailey
Shellie Bailey

INFORMATION DISCLOSURE STATEMENT RECEIVED

Assistant Commissioner for Patents
Washington, D.C. 20231

JUL 16 1999

Sir:

TECHNOLOGY CENTER 2800

In compliance with the duty of disclosure under 37 C.F.R. § 1.56, and in accordance with the practice under 37 C.F.R. § 1.97 and § 1.98, the Examiner's attention is directed to the documents listed on the enclosed Form PTO-1449.

This Information Disclosure Statement is being filed within three months of the U.S. filing date or before the mailing date of a first Office Action on the merits. No certification or fee is required (37 CFR §1.97(b)).

Documents AN through AR, and AL1 through AQ1 in this Information Disclosure Statement were cited in a communication from a foreign Patent Office in a counterpart foreign application. The concise explanation of relevance for the non-English documents is provided therein.

The concise explanation of relevance for documents AL2 and AM2 are provided on page 1 of the subject application.

Copies of the remaining documents were cited by or submitted to the Office in Application No. 08/204,374, filed May 10, 1994, and Application No. 08/689,424, filed August 9, 1996, which are relied upon for an earlier filing date

P1933.D2

09/321,687

Information Disclosure Statement

under 35 U.S.C. §120, and or Application No. 08/794,652, filed February 3, 1997, which is related in subject matter.

CONCLUSION

The Commissioner is hereby authorized to charge any additional fees which may be required, or credit any over-payment to Deposit Account 19-2746.

It is respectfully requested that the above information be considered by the Examiner and that a copy of the enclosed Form PTO-1449 be initialed and returned indicating that such information has been considered.

Respectfully submitted,



Mark P. Watson
Attorney for Applicants
Registration No. 31,448

Please address all correspondence to:

Epson Research and Development, Inc.
Intellectual Property Department
225 Baypointe Parkway
San Jose, CA 95134
Customer No. 20178
Phone: (408)952-6000
Fax: (408) 954-9058

Date: June 30, 1999

Form PTO-1449 (REV 8-83)	DEPARTMENT OF COMMERCE PATENT AND TRADEMARK OFFICE	SERIAL NO. 09/321,687	ATTY DOCKET NO. P1933.D2
INFORMATION DISCLOSURE CITATION (USE SEVERAL SHEETS IF NECESSARY) PAGE 1 OF 5		APPLICANTS Tatsuaki Funamoto, et al.	
		FILING DATE May 28, 1999	GROUP <u>2871</u> Not Yet Assigned

U.S. PATENT DOCUMENTS

E.I.	DOCUMENT NUMBER	DATE	NAME	CLASS	SUBCLASS	FILING DATE
wjm	AA 5,363,294	11/8/94	Yamamoto, et al.	362	026	
wjm	AB 5,283,673	2/1/94	Murase, et al.	362	031	
wjm	AC 5,134,549	7/28/92	Yokoyama	362	031	
wjm	AD 5,130,898	7/14/92	Akahane	362	031	
wjm	AE 5,057,974	10/15/91	Mizobe	362	026	
wjm	AF 4,985,809	1/15/91	Matsui, et al.	362	031	
wjm	AG 4,974,122	11/27/90	Shaw	362	031	
wjm	AH 4,842,378	6/27/89	Flasck, et al.	362	031	
wjm	AI 4,729,067	3/1/88	Ohe	362	026	
wjm	AJ 4,568,179	2/4/86	Durbin, et al.	362	343	
wjm	AK 4,729,068	3/1/88	Ohe	362	031	

FOREIGN PATENT DOCUMENTS

E.I.	DOCUMENT NUMBER	DATE	COUNTRY	CLASS	SUBCLASS	TRANSLATION
wjm	AL 4-102888	4/3/92	Japan	---	---	Abstract
wjm	AM 1-183626	7/21/89	Japan	---	---	Abstract
wjm	AN 0 317 250	5/24/89	EPO	---	---	
wjm	AO 0 442 529	8/21/91	EPO	---	---	
wjm	AP 62-102226	5/12/87	Japan	---	---	Abstract
wjm	AQ WO88/08149	10/20/88	PCT	---	---	

OTHER DOCUMENTS (INCLUDING AUTHOR, TITLE, DATE, PERTINENT PAGES, ETC.)

wjm	AR	"Advancements In Backlighting Technologies For LCDs", K. Hathaway, SPIE Proceedings, High-Resolution Displays and Projection Systems, Volume 1664, February 1992, pp. 108-116.
wjm	AS	Electronic Design, Aug. 2, 1961, p. 47.
wjm	AT	Voltarc Technical Bulletin "Fluorescent Lamp", 1987.

EXAMINER <i>Walter Malinowski</i>	DATE CONSIDERED <i>September 14 1999</i>
--------------------------------------	---

EXAMINER: Initial if reference considered, whether or not citation is in conformance with MPEP 609; draw line through citation if not in conformance and not considered. Include copy of this form with next communication to the applicant.

Form PTO-1449 (REV 8-83)	DEPARTMENT OF COMMERCE PATENT AND TRADEMARK OFFICE	SERIAL NO. 09/321,687	ATTY DOCKET NO. P1933.D2
INFORMATION DISCLOSURE CITATION (USE SEVERAL SHEETS IF NECESSARY) PAGE 2 OF 5		APPLICANT Tatsuaki Funamoto, et al.	
		FILING DATE May 28, 1999	GROUP 2871 Not Yet Assigned

U.S. PATENT DOCUMENTS

E.I.	DOCUMENT NUMBER	DATE	NAME	CLASS	SUBCLASS	FILING DATE
wjm	AA1 4,811,507	3/14/89	Blanchet	362	031	
wjm	AB1 3,968,584	7/13/76	Kingston	362	031	
wjm	AC1 4,933,814	6/12/90	Sanai	362	031	
wjm	AD1 3,892,959	7/1/75	Pulles	362	031	
wjm	AE1 4,860,171	8/22/89	Kojima	362	031	
wjm	AF1 5,124,890	6/23/92	Choi, et al.	362	027	
wjm	AG1 4,630,895	12/23/86	Abdala Jr., et al.	362	031	
wjm	AH1 4,648,690	3/10/87	Ohe	362	031	
	AI1					
	AJ1					
	AK1					

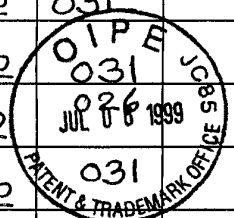

RECEIVED
JUL 16 1999

TECHNOLOGY CENTER 2800

FOREIGN PATENT DOCUMENTS

E.I.	DOCUMENT NUMBER	DATE	COUNTRY	CLASS	SUBCLASS	TRANSLATION
wjm	AL1 2 632 432	12/8/89	France	 	 	
wjm	AM1 54-40086	3/28/79	Japan	 	 	Abstract
wjm	AN1 3-15476	5/20/91	Japan	 	 	
wjm	AO1 61-166585	7/28/86	Japan	 	 	
wjm	AP1 63-45537	3/28/88	Japan	 	 	
wjm	AQ1 63-124217	8/12/88	Japan	 	 	

OTHER DOCUMENTS (INCLUDING AUTHOR, TITLE, DATE, PERTINENT PAGES, ETC.)

	AR1	
	AS1	
	AT1	

EXAMINER <i>Walter Malinowski</i>	DATE CONSIDERED <i>September 14 1999</i>
--------------------------------------	---

EXAMINER: Initial if reference considered, whether or not citation is in conformance with MPEP 609; draw line through citation if not in conformance and not considered. Include copy of this form with next communication to the applicant.

Form PTO-1449 (REV 8-83)	DEPARTMENT OF COMMERCE PATENT AND TRADEMARK OFFICE	SERIAL NO. 09/321,687	ATTY DOCKET NO. P1933.D2
INFORMATION DISCLOSURE CITATION (USE SEVERAL SHEETS IF NECESSARY) PAGE 3 OF 5		APPLICANT Tatsuaki Funamoto, et al.	
		FILING DATE May 28, 1999	GROUP Not Yet Assigned

U.S. PATENT DOCUMENTS

E.I.	DOCUMENT NUMBER	DATE	NAME	CLASS	SUBCLASS	FILING DATE
	AA2					
	AB2					
	AC2					
	AD2					
	AE2					
	AF2					
	AG2					
	AH2					
	AI2					
	AJ2					
	AK2					

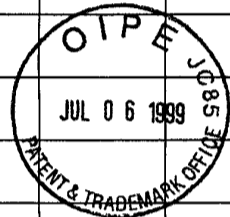

RECEIVED

JUL 16 1999

TECHNOLOGY CENTER 2800

FOREIGN PATENT DOCUMENTS

E.I.	DOCUMENT NUMBER	DATE	COUNTRY	CLASS	SUBCLASS	TRANSLATION
wjm	AL2	60-205576	10/17/85	Japan		
wjm	AM2	61-248079	11/5/86	Japan		
wjm	AN2	63-062105	3/18/88	Japan		
wjm	AO2	63-175301	7/19/88	Japan		
wjm	AP2	64-45002	2/17/89	Japan		
wjm	AQ2	64-45003	2/17/89	Japan		

OTHER DOCUMENTS (INCLUDING AUTHOR, TITLE, DATE, PERTINENT PAGES, ETC.)

	AR2	
	AS2	
	AT2	

EXAMINER <i>Walter Malinowski</i>	DATE CONSIDERED <i>September 14 1999</i>
--------------------------------------	---

EXAMINER: Initial if reference considered, whether or not citation is in conformance with MPEP 609; draw line through citation if not in conformance and not considered. Include copy of this form with next communication to the applicant.

Form PTO-1449 (REV 8-83)	DEPARTMENT OF COMMERCE PATENT AND TRADEMARK OFFICE	SERIAL NO. 09/321,687	ATTY DOCKET NO. P1933.D2
		APPLICANT Tatsuaki Funamoto, et al.	
		FILING DATE May 28, 1999	GROUP 2871 Not Yet Assigned

INFORMATION DISCLOSURE CITATION
(USE SEVERAL SHEETS IF NECESSARY)
PAGE 4 OF 5

U.S. PATENT DOCUMENTS

E.I.	DOCUMENT NUMBER	DATE	NAME	CLASS	SUBCLASS	FILING DATE
	AA3					
	AB3					
	AC3					
	AD3					
	AE3					
	AF3					
	AG3					
	AH3					
	AI3					
	AJ3					
	AK3					

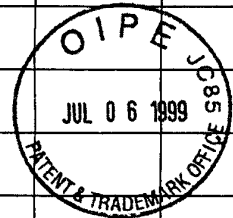

RECEIVED

JUL 16 1999

TECHNOLOGY CENTER 2800

FOREIGN PATENT DOCUMENTS

E.I.	DOCUMENT NUMBER	DATE	COUNTRY	CLASS	SUBCLASS	TRANSLATION
wjm	AL3 0 327 493	3/15/58	France	 	 	
wjm	AM3 0 587 766	4/21/25	France	 	 	
wjm	AN3 0 664 193	1/2/52	Great Britain	 	 	
wjm	AO3 1 145 934	10/30/57	France	 	 	
wjm	AP3 3-201304	9/3/91	Japan	 	 	Abstract
wjm	AQ3 54-40086	3/28/79	Japan	 	 	Abstract

OTHER DOCUMENTS (INCLUDING AUTHOR, TITLE, DATE, PERTINENT PAGES, ETC.)

AR3	
AS3	
AT3	

EXAMINER <i>Walter Malinowski</i>	DATE CONSIDERED <i>September 14 1999</i>
--------------------------------------	---

EXAMINER: Initial if reference considered, whether or not citation is in conformance with MPEP 609; draw line through citation if not in conformance and not considered. Include copy of this form with next communication to the applicant.

Form PTO-1449
(REV 8-83)

DEPARTMENT OF COMMERCE
PATENT AND TRADEMARK OFFICE

SERIAL NO. 09/321,687

ATTY DOCKET NO.
P1933.D2

INFORMATION DISCLOSURE CITATION
(USE SEVERAL SHEETS IF NECESSARY)
PAGE 5 OF 5

APPLICANT

Tatsuaki Funamoto, et al.

FILING DATE

May 28, 1999

GROUP

2871

~~Not Yet Assigned~~

U.S. PATENT DOCUMENTS

E.I.	DOCUMENT NUMBER	DATE	NAME	CLASS	SUBCLASS	FILING DATE
	AA3					
	AB3					
	AC3					
	AD3					
	AE3					
	AF3					
	AG3					
	AH3					
	AI3					
	AJ3					
	AK3					

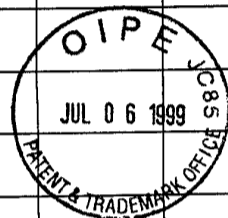

RECEIVED
JUL 16 1999
TECHNOLOGY CENTER 2800

FOREIGN PATENT DOCUMENTS

E.I.	DOCUMENT NUMBER	DATE	COUNTRY	CLASS	SUBCLASS	TRANS-LATION
wjm	AL3 2 620 795	3/24/89	France			Yes
wjm	AM3 0 561 329	9/22/93	EPO			
	AN3					
	AO3					
	AP3					
	AQ3					

OTHER DOCUMENTS (INCLUDING AUTHOR, TITLE, DATE, PERTINENT PAGES, ETC.)

	AR3	
	AS3	
	AT3	

EXAMINER

Walter Malinowski

DATE CONSIDERED

September 14 1999

EXAMINER: Initial if reference considered, whether or not citation is in conformance with MPEP 609; draw line through citation if not in conformance and not considered. Include copy of this form with next communication to the applicant.

P1933.D2

#3/PM-a
A Ford
8/19/99
PATENT

IN THE UNITED STATES PATENT AND TRADEMARK OFFICE

Inventors: Tatsuaki Funamoto, et al Group Art Unit: Not Yet Assigned
 Serial No.: 09/321,687 Examiner: Not Yet Assigned
 Filed: May 28, 1999
 Title: Surface-Type Illumination Device And Liquid Crystal Display



CERTIFICATE OF MAILING

I hereby certify that this correspondence is being deposited with the United States Postal Service as First Class mail in an envelope addressed to Assistant Commissioner for Patents, Washington, D.C. 20231 on this date.
 Date: June 29, 1999

Shellie Bailey
 Shellie Bailey

PRELIMINARY AMENDMENT

Assistant Commissioner for Patents
Washington, D.C. 20231

Sir:

Preliminary to examination please amend the subject application as follows:

RECEIVED
JUL 12 1999
TC 2800 MAIL ROOM

IN THE CLAIMS:

Please cancel Claim 1 without prejudice or disclaimer.

Please add the following new claims:

~~2.~~^{1.} An illumination device comprising:

a substantially transparent and polygon-shaped light guide plate comprising at least first and second side edges;

an elongated illuminant comprising an L-shaped section facing said at least first and second side edges of said light guide plate;

said light guide plate comprising a cutout portion at a corner between said first and second side edges so as not to interfere with a facing bend in said L-shaped section of said elongated illuminant;

al

said cutout portion comprising a first leg and a second leg, said first leg being substantially parallel to said second side edge, and said second leg being substantially parallel to said first side edge.

²/~~3~~. An illumination device according to Claim ¹/~~2~~ comprising a gap distance in a range of about 0.8 to 1.5 mm formed between at least one of said first and second side edges and said facing illuminant.

³/~~4~~. An illumination device according to Claim ²/~~3~~ wherein said gap distance is in a range of about 1.0 to 1.5 mm.

⁴/~~5~~. An illumination device according to Claim ¹/~~2~~ wherein an aperture ratio, defined as a thickness of said light guide plate/a diameter of said illuminant, is in the range of about 0.9 to 2.0.

⁵/~~6~~. An illumination device according to Claim ¹/~~2~~ further comprising a reflecting member covering said cutout portion.

cut
⁶/~~7~~. An illumination device according to Claim ¹/~~2~~ wherein the length of one of said first and second legs is approximately 0.6 times to 1.0 times the smallest radius of curvature of said facing bend in said L-shaped illuminant.

⁷/~~8~~. An illumination device according to Claim ¹/~~2~~ further comprising a reflector covering said illuminant except in regions of said illuminant facing said first and second side edges of said light guide plate, said reflector comprising a first reflector portion and a second reflector portion positioned along legs of said L-shaped section of said illuminant.

⁸/~~9~~. An illumination device according to Claim ¹/~~2~~ further comprising a reflector covering said illuminant except in regions of said illuminant facing said first and second side edges of said light guide plate, said reflector comprising a first portion covering a lower portion of said illuminant and a second portion covering an upper portion of said illuminant.

9
10. An illumination device according to Claim ~~2~~¹ wherein said light guide has a thickness formed so that it is inversely proportional to a density distribution calculated by:

computing a first predicted emitted light intensity distribution for a first direction along said first side edge based on the intensity of the light incident on said light guide plate from said second side edge and the density distribution of a presupposed diffusion pattern;

computing a second predicted emitted light intensity distribution for a second direction along said second side edge based on the intensity of the light incident on said light guide plate from said first side and the density distribution of the presupposed diffusion pattern; and

at
computing the density distribution of said diffusion pattern by compensating the density distribution of the presupposed diffusion pattern so that the sum of said first predicted emitted light intensity distribution and said second predicted emitted light intensity distribution on arbitrary rectangular coordinates of said light guide plate fit within a fixed range.

Just
B1
11. An illumination device according to Claim ~~10~~⁹ further comprising an edge reflector disposed along at least one of two side edges of said light guide plate opposite to said first side edge and said second side edge, said edge reflector reflecting the light emitted by said light guide plate back to said light guide plate; and the density distribution of said diffusion pattern is computed by:

computing an intensity of light reflected by from said edge reflector and incident on said light guide plate with a fixed attenuation factor;

computing a predicted emitted light intensity distribution for at least one of the first and second directions for said reflected light intensity; and

adding the predicted emitted light intensity distribution to the sum of said first predicted emitted light intensity distribution and said second predicted

emitted light intensity distribution which are on arbitrary rectangular coordinates of said light guide plate.

¹¹
11. An illumination device according to Claim ¹~~2~~ further comprising a liquid crystal display that is illuminated by light emitted from one side of said light guide plate by a diffusion pattern formed on the other side of said light guide plate; and

Panel
a driver that drives said liquid crystal display, said driver arranged along two side edges of said light guide plate opposing said first and second side edges of said light guide plate.

¹²
12. An illumination device according to Claim ¹~~2~~ wherein said illuminant is substantially U-shaped and faces said first and second side edges and a third side edge of said light guide plate.--

REMARKS

The foregoing amendments are intended to present the claims in better form for examination in the subject application.

Respectfully submitted,

Mark P. Watson

Mark P. Watson
Attorney for Applicants
Registration No. 31,448

Please address all correspondence to:

Epson Research and Development, Inc.
Intellectual Property Department
225 Baypointe Parkway
San Jose, CA 95134
Phone: (408) 952-6000
Fax: (408) 954-9058
Customer No. 20178

Date: June 29, 1999

Attorney's Docket No. P1933.D2

FAD 2871
PATENT

IN THE UNITED STATES PATENT AND TRADEMARK OFFICE

Inventors: Tatsuaki Funamoto, et al. Group Art Unit: Not Yet Assigned
Serial No.: 09/321,687 Examiner: Not Yet Assigned
Filed: May 28, 1999
Title: Surface-Type Illumination Device And Liquid Crystal Display



CERTIFICATE OF MAILING
I hereby certify that this correspondence is being deposited with the United States Postal Service as first class mail in an envelope addressed to the Assistant Commissioner for Patents, Washington, DC 20231 on this date.
Date: June 29, 1999
Shellie Bailey
Shellie Bailey

AMENDMENT TRANSMITTAL LETTER AND PETITION FOR EXTENSION OF TIME UNDER 37 CFR 1.136(a) (IF REQUIRED)

Assistant Commissioner for Patents
Washington, D.C. 20231

Transmitted herewith is an amendment in the above-identified application. The fee is calculated as shown below

RECEIVED
JUL 12 1999
TC 800 MAIL ROOM

Claims Remaining After Amendment	Highest # Previously Paid For	# Extra	Rate	Additional Fee
Total Claims: 12 -	20	0	\$18.00	\$0
Independent Claims: 1 -	3	0	\$78.00	\$0
<input type="checkbox"/> 1st Presentation of Multiple Dependent Claim			\$260.00	\$0
TOTAL ADDITIONAL FEE FOR THIS AMENDMENT				\$0

- No additional fee is required.
- Applicant(s) petition for an extension of time under 37 CFR 1.136 (fees: 37 CFR 1.17(a)-(d) for the total number of months checked below.

Extension (Months)	Fee For Large Entity
<input type="checkbox"/> One (1) Month	\$110.00
<input type="checkbox"/> Two (2) Months	\$380.00
<input type="checkbox"/> Three (3) Months	\$870.00
<input type="checkbox"/> Four (4) Months	\$1360.00

FEE: \$

- If an additional extension of time is required, please consider this a petition therefor together with authorization to charge Deposit Account No. 19-2746 for any additional extension fee.
- Relative to response to the Final Office Action, an extension for ____ months has already been secured and the fee paid therefor of \$ ____ is deducted from the total fee due for the total months of extension now requested.
- Applicant believes that no extension of time is required. However, this conditional petition is being made to provide for the possibility that applicant has inadvertently overlooked the need for a petition for extension of time.

P1933.D2

09/321,687

Amendment Transmittal

- Enclosed is an Information Disclosure Statement together with Form PTO-1449 and a copy of ___ cited references:
- Enclosed is a certification under 37 CFR 1.97(e).
 - The Commissioner is hereby authorized to charge the fee of \$240.00 under 37 CFR 1.17(p) to Deposit Account No. 19-2746.
- Enclosed is a Request To Amend The Drawings and a copy of Fig. _____.
- The Commissioner is hereby authorized to charge payment of the following fees during the pendency of this application or credit any overpayment to our Deposit Account No. 19-2746. A duplicate copy of this transmittal letter is enclosed.
- Any additional filing fees required under 37 CFR 1.16.
 - Any patent application processing fees under 37 CFR 1.16.
- The Commissioner is hereby authorized to charge payment of the following fees associated with this communication or credit any overpayment to our Deposit Account No. 19-2746. A duplicate copy of this transmittal letter is enclosed.
- Any additional filing fees required under 37 CFR 1.16.
 - Any patent application processing fees under 37 CFR 1.16.
- Enclosed is a Submission Under 37 CFR §1.129(a).
- Please charge Deposit Account No. 19-2746 the sum of \$_____. A duplicate of this transmittal letter is attached.

Date: June 29, 1999

Respectfully submitted,



Mark P. Watson
Attorney for Applicants
Registration No. 31,448

Please address all correspondence to:
Epson Research and Development Inc.
Intellectual Property Department
225 Baypointe Parkway
San Jose, CA 95134
Telephone No.: (408) 952-6000
Fax: (408) 954-9058
Customer No. 20178



**UNITED STATES DEPARTMENT OF COMMERCE
Patent and Trademark Office**

Address: COMMISSIONER OF PATENTS AND TRADEMARKS
Washington, D.C. 20231

APPLICATION NO.	FILING DATE	FIRST NAMED INVENTOR	ATTORNEY DOCKET NO.
09/321,687	05/28/99	FUNAMOTO	T P1933.D2

020178 MM21/0922
EPSON RESEARCH AND DEVELOPMENT INC
INTELLECTUAL PROPERTY DEPT
225 BAYPOINTE PARKWAY
SAN JOSE CA 95134

EXAMINER

MALINOWSKI, W

ART UNIT PAPER NUMBER

2871

DATE MAILED: 09/22/99

Please find below and/or attached an Office communication concerning this application or proceeding.

Commissioner of Patents and Trademarks

Notice of Allowability

Application No. 09/321,687	Applicant(s) Funamoto et al.
Examiner Walter Malinowski	Group Art Unit 2871



All claims being allowable, PROSECUTION ON THE MERITS IS (OR REMAINS) CLOSED in this application. If not included herewith (or previously mailed), a Notice of Allowance and Issue Fee Due or other appropriate communication will be mailed in due course.

- This communication is responsive to application filed May 28 1999
- The allowed claim(s) is/are 2-13
- The drawings filed on May 28, 1999 are acceptable.
- Acknowledgement is made of a claim for foreign priority under 35 U.S.C. § 119(a)-(d).
- All Some* None of the CERTIFIED copies of the priority documents have been
- received.
- received in Application No. (Series Code/Serial Number) 08/204,374
- received in this national stage application from the International Bureau (PCT Rule 17.2(a)).
- *Certified copies not received: _____
- Acknowledgement is made of a claim for domestic priority under 35 U.S.C. § 119(e).

A SHORTENED STATUTORY PERIOD FOR RESPONSE to comply with the requirements noted below is set to EXPIRE **THREE MONTHS FROM THE "DATE MAILED"** of this Office action. Failure to timely comply will result in ABANDONMENT of this application. Extensions of time may be obtained under the provisions of 37 CFR 1.136(a).

- Note the attached EXAMINER'S AMENDMENT or NOTICE OF INFORMAL APPLICATION, PTO-152, which discloses that the oath or declaration is deficient. A SUBSTITUTE OATH OR DECLARATION IS REQUIRED.
- Applicant MUST submit NEW FORMAL DRAWINGS
- because the originally filed drawings were declared by applicant to be informal.
- including changes required by the Notice of Draftsperson's Patent Drawing Review, PTO-948, attached hereto or to Paper No. _____
- including changes required by the proposed drawing correction filed on _____, which has been approved by the examiner.
- including changes required by the attached Examiner's Amendment/Comment.

Identifying indicia such as the application number (see 37 CFR 1.84(c)) should be written on the reverse side of the drawings. The drawings should be filed as a separate paper with a transmittal letter addressed to the Official Draftsperson.

- Note the attached Examiner's comment regarding REQUIREMENT FOR THE DEPOSIT OF BIOLOGICAL MATERIAL.

Any response to this letter should include, in the upper right hand corner, the APPLICATION NUMBER (SERIES CODE/SERIAL NUMBER). If applicant has received a Notice of Allowance and Issue Fee Due, the ISSUE BATCH NUMBER and DATE of the NOTICE OF ALLOWANCE should also be included.

Attachment(s)

- Notice of References Cited, PTO-892
- Information Disclosure Statement(s), PTO-1449, Paper No(s) 2
- Notice of Draftsperson's Patent Drawing Review, PTO-948
- Notice of Informal Patent Application, PTO-152
- Interview Summary, PTO-413
- Examiner's Amendment/Comment
- Examiner's Comment Regarding Requirement for Deposit of Biological Material
- Examiner's Statement of Reasons for Allowance

Application/Control Number: 09/321,687

Page 2

Art Unit: 2871

DETAILED ACTION

Allowable Subject Matter

1. Claims 2-13 are allowed.
2. The following is an examiner's statement of reasons for allowance:

As to Claims 2-13, no prior art of record teaches or fairly suggests an illumination device comprising a substantially transparent and polygon-shaped light guide plate comprising at least first and second side edges; an elongated illuminant comprising an L-shaped section facing the at least first and second side edges of the light guide plate; the light guide plate comprising a cutout portion at a corner between the first and second side edges so as not to interfere with a facing bend in the L-shaped section of the elongated illuminant; the cutout portion comprising a first leg and a second leg, the first leg being substantially parallel to the second side edge, and the second leg being substantially parallel to the first side edge.

Any comments considered necessary by applicant must be submitted no later than the payment of the issue fee and, to avoid processing delays, should preferably accompany the issue fee. Such submissions should be clearly labeled "Comments on Statement of Reasons for Allowance."

Application/Control Number: 09/321,687

Page 3

Art Unit: 2871

Conclusion

3. The prior art made of record and not relied upon is considered pertinent to applicant's disclosure.

Funamoto et al., U.S. Patent No. 5,949,505

Liao, U.S. Patent No. 5,764,493

4. Any inquiry concerning this communication or earlier communications from the examiner should be directed to Walter Malinowski whose telephone number is (703) 308-3172.

wjm

September 15, 1999

WILLIAM L. SIKES
SUPERVISORY PATENT EXAMINER
GROUP 2500

09/321687

NOTICE OF DRAFTSPERSON'S PATENT DRAWING REVIEW

The drawing(s) filed (insert date) 5/28/99

- A. [X] approved by the Draftsperson under 37 CFR 1.84 or 1.152.
B. [] objected to by the Draftsperson under 37 CFR 1.84 or 1.152 for the reasons indicated below. The Examiner will require submission of new, corrected drawings when necessary. Corrected drawing must be submitted according to the instructions on the back of this notice.

1. DRAWINGS. 37 CFR 1.84(a): Acceptable categories of drawings:
Black ink. Color. Color drawings are not acceptable until petition is granted.
Fig(s)
Pencil and non black ink not permitted. Fig(s)
2. PHOTOGRAPHS. 37 CFR 1.84 (b)
1 full-tone set is required. Fig(s)
Photographs not properly mounted (must use bristol board or photographic double-weight paper). Fig(s)
Poor quality (half-tone). Fig(s)
3. TYPE OF PAPER. 37 CFR 1.84(e)
Paper not flexible, strong, white, and durable. Fig(s)
Erasures, alterations, overwritings, interlineations, folds, copy machine marks not accepted. Fig(s)
Mylar, velum paper is not acceptable (too thin). Fig(s)
4. SIZE OF PAPER. 37 CFR 1.84(f): Acceptable sizes:
21.0 cm by 29.7 cm (DIN size A4)
21.6 cm by 27.9 cm (8 1/2 x 11 inches)
All drawing sheets not the same size.
Sheet(s)
Drawings sheets not an acceptable size. Fig(s)
5. MARGINS. 37 CFR 1.84(g): Acceptable margins:
Top 2.5 cm Left 2.5cm Right 1.5 cm Bottom 1.0 cm
SIZE: A4 Size
Top 2.5 cm Left 2.5 cm Right 1.5 cm Bottom 1.0 cm
SIZE: 8 1/2 x 11.
Margins not acceptable. Fig(s)
Top (T) Left (L)
Right (R) Bottom (B)
6. VIEWS. 37 CFR 1.84(h)
REMINDER: Specification may require revision to correspond to drawing changes.
Partial views. 37 CFR 1.84(h)(2)
Brackets needed to show figure as one entity. Fig(s)
Views not labeled separately or properly. Fig(s)
Enlarged view not labeled separately or properly. Fig(s)
7. SECTIONAL VIEWS. 37 CFR 1.84 (h)(3)
Hatching not indicated for sectional portions of an object. Fig(s)
Sectional designation should be noted with Arabic or Roman numbers. Fig(s)
8. ARRANGEMENT OF VIEWS. 37 CFR 1.84(i)
Words do not appear on a horizontal, left-to-right fashion when page is either upright or turned so that the top becomes the right side, except for graphs. Fig(s)
9. SCALE. 37 CFR 1.84(k)
Scale not large enough to show mechanism without crowding when drawing is reduced in size to two-thirds in reproduction. Fig(s)
10. CHARACTER OF LINES, NUMBERS, & LETTERS. 37 CFR 1.84(i)
Lines, numbers & letters not uniformly thick and well defined, clean, durable, and black (poor line quality). Fig(s)
11. SHADING. 37 CFR 1.84(m)
Solid black areas pale. Fig(s)
Solid black shading not permitted. Fig(s)
Shade lines, pale, rough and blurred. Fig(s)
12. NUMBERS, LETTERS, & REFERENCE CHARACTERS. 37 CFR 1.84(p)
Numbers and reference characters not plain and legible. Fig(s)
Figure legends are poor. Fig(s)
Numbers and reference characters not oriented in the same direction as the view. 37 CFR 1.84(p)(1) Fig(s)
English alphabet not used. 37 CFR 1.84(p)(2) Figs
Numbers, letters and reference characters must be at least .32 cm (1/8 inch) in height. 37 CFR 1.84(p)(3) Fig(s)
13. LEAD LINES. 37 CFR 1.84(q)
Lead lines cross each other. Fig(s)
Lead lines missing. Fig(s)
14. NUMBERING OF SHEETS OF DRAWINGS. 37 CFR 1.84(t)
Sheets not numbered consecutively, and in Arabic numerals beginning with number 1. Sheet(s)
15. NUMBERING OF VIEWS. 37 CFR 1.84(u)
Views not numbered consecutively, and in Arabic numerals, beginning with number 1. Fig(s)
16. CORRECTIONS. 37 CFR 1.84(w)
Corrections not made from prior PTO-948 dated
17. DESIGN DRAWINGS. 37 CFR 1.152
Surface shading shown not appropriate. Fig(s)
Solid black shading not used for color contrast. Fig(s)
COMMENTS

REVIEWER

CBR

DATE

9/15/99

TELEPHONE NO.

703 3058 8006

ATTACHMENT TO PAPER NO.

4

Notice of References Cited

Application No. 09/321,687	Applicant(s) Funamoto et al.	
Examiner Walter Malinowski	Group Art Unit 2871	Page 1 of 1

U.S. PATENT DOCUMENTS

*		DOCUMENT NO.	DATE	NAME	CLASS	SUBCLASS
x	A	5,949,505	Sep/ 1999	Funamoto et al.	349	065
x	B	5,764,493	Jun/ 1998	Liao	362	031
	C					
	D					
	E					
	F					
	G					
	H					
	I					
	J					
	K					
	L					
	M					

FOREIGN PATENT DOCUMENTS

*		DOCUMENT NO.	DATE	COUNTRY	NAME	CLASS	SUBCLASS
	N						
	O						
	P						
	Q						
	R						
	S						
	T						

NON-PATENT DOCUMENTS

*		DOCUMENT (Including Author, Title, Source, and Pertinent Pages)	DATE
	U		
	V		
	W		
	X		

* A copy of this reference is not being furnished with this Office action.
(See Manual of Patent Examining Procedure, Section 707.05(a).)



Amendment Under 37 CFR §1.312
Notice Of Allowance Dated: September 22, 1999
Batch No. B84
PATENT

P1933.D2

IN THE UNITED STATES PATENT AND TRADEMARK OFFICE

Inventors: Tatsuaki Funamoto, et al. Group Art Unit: 2871
Serial No.: 09/321,687 Examiner: W. Malinowski
Filed: May 28, 1999
Title: Surface-Type Illumination Device And Liquid Crystal Display

#5/B
Pres
(312)
Marsha
3/7/00

CERTIFICATE OF MAILING
I hereby certify that this correspondence is being deposited with the United States Postal Service as First Class Mail in an envelope addressed to: Box Issue Fee, Assistant Commissioner for Patents, Washington, DC 20231 on this date.
Date: September 30, 1999
Shellie Bailey
Shellie Bailey

AMENDMENT AFTER ALLOWANCE
Under 37 CFR §1.312

Box Issue Fee
Assistant Commissioner For Patents
Washington, D.C. 20231

Sir:

Applicants having received a Notice Of Allowance dated September 22, 1999, please amend the subject application as follows, pursuant to 37 CFR §1.312:

IN THE CLAIMS:

Please amend Claim 11 as follows:

11. (Amended) An illumination device according to Claim 10 further comprising an edge reflector disposed along at least one of two side edges of said light guide plate opposite to said first side edge and said second side edge, said edge reflector reflecting the light emitted by said light guide plate back to said light guide plate; and the density distribution of said diffusion pattern is computed by:

B1

P1933.D2

09/321,687

Amendment Under 37 CFR §1.312

computing an intensity of light reflected by [from] said edge reflector and incident on said light guide plate with a fixed attenuation factor;

computing a predicted emitted light intensity distribution for at least one of the first and second directions for said reflected light intensity; and

adding the predicted emitted light intensity distribution to the sum of said first predicted emitted light intensity distribution and said second predicted emitted light intensity distribution which are on arbitrary rectangular coordinates of said light guide plate.

REMARKS

Claim 11 has been amended as to matters of form. It is respectfully submitted that the proposed changes do not raise any new issues or require any further searching or consideration. Accordingly, entry of this amendment after allowance pursuant to 37 C.F.R. § 1.312 is respectfully requested.

Respectfully Submitted,



Mark P. Watson
Attorney for Applicants
Registration No. 31,448

Please address all correspondence to:
Epson Research and Development, Inc.
Intellectual Property Department
225 Baypointe Parkway
San Jose, CA 95134
Phone: (408) 952-6000
FAX: (408) 954-9058
Customer No. 20178

Date: September 30, 1999

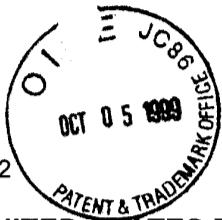

NOTICE OF ALLOWANCE DATED: September 22, 1999
BATCH NO. B84

B

Attorney's Docket No. P1933.D2

PATENT

IN THE UNITED STATES PATENT AND TRADEMARK OFFICE

Inventors: Tatsuaki Funamoto, et al. Group Art Unit: 2871
Serial No.: 09/321,687 Examiner: W. Malinowski
Filed: May 28, 1999
Title: Surface-Type Illumination Device And Liquid Crystal Display

CERTIFICATE OF MAILING

I hereby certify that this correspondence is being deposited with the United States Postal Service as first class mail in an envelope addressed to Box Issue Fee, Assistant Commissioner for Patents, Washington, DC 20231 on this date.

Date: September 30, 1999

Shellie Bailey
Shellie Bailey

**AMENDMENT TRANSMITTAL LETTER AND
PETITION FOR EXTENSION OF TIME UNDER 37 CFR 1.136(a) (IF REQUIRED)**

**BOX ISSUE FEE
US PATENT AND TRADEMARK OFFICE
WASHINGTON, D.C. 20231**

Transmitted herewith is an amendment in the above-identified application. The fee is calculated as shown below:

Claims Remaining After Amendment	Highest # Previously Paid For	# Extra	Rate	Additional Fee
Total Claims: 12 -	20	0	\$18.00	\$0
Independent Claims: 1 -	3	0	\$78.00	\$0
<input type="checkbox"/> 1st Presentation of Multiple Dependent Claim			\$260.00	\$0
TOTAL ADDITIONAL FEE FOR THIS AMENDMENT				\$0

- No additional fee is required.
- Applicant(s) petition for an extension of time under 37 CFR 1.136 (fees: 37 CFR 1.17(a)-(d) for the total number of months checked below.

RECEIVED

OCT 06 1999

Publishing Division

Extension (Months)	Fee For Large Entity
<input type="checkbox"/> One (1) Month	\$110.00
<input type="checkbox"/> Two (2) Months	\$380.00
<input type="checkbox"/> Three (3) Months	\$870.00
<input type="checkbox"/> Four (4) Months	\$1360.00

FEE: \$

- If an additional extension of time is required, please consider this a petition therefor together with authorization to charge Deposit Account No. 19-2746 for any additional extension fee.
- Relative to response to the Final Office Action, an extension for _____ months has already been secured and the fee paid therefor of \$_____ is deducted from the total fee due for the total months of extension now requested.

P1933.D2

09/321,687

Amendment Transmittal

- Applicant believes that no extension of time is required. However, this conditional petition is being made to provide for the possibility that applicant has inadvertently overlooked the need for a petition for extension of time.
- Enclosed is an Information Disclosure Statement together with Form PTO-1449 and a copy of ___ cited references:
- Enclosed is a certification under 37 CFR 1.97(e).
- The Commissioner is hereby authorized to charge the fee of 240.00 under 37 CFR 1.17(p) to Deposit Account No. 19-2746.
- Enclosed is a Request To Amend The Drawings and a copy of Fig. _____.
- The Commissioner is hereby authorized to charge payment of the following fees during the pendency of this application or credit any overpayment to our Deposit Account No. 19-2746. A duplicate copy of this transmittal letter is enclosed.
- Any additional filing fees required under 37 CFR 1.16.
- Any patent application processing fees under 37 CFR 1.16.
- The Commissioner is hereby authorized to charge payment of the following fees associated with this communication or credit any overpayment to our Deposit Account No. 19-2746. A duplicate copy of this transmittal letter is enclosed.
- Any additional filing fees required under 37 CFR 1.16.
- Any patent application processing fees under 37 CFR 1.16.
- Enclosed is a Submission Under 37 CFR §1.129(a).
- Please charge Deposit Account No. 19-2746 the sum of \$_____. A duplicate of this transmittal letter is attached.

Date: September 30, 1999

Respectfully submitted,



Mark P. Watson

Attorney for Applicants
Registration No. 31,448

Please address all correspondence to:
Epson Research and Development Inc.
Intellectual Property Department
225 Baypointe Parkway
San Jose, CA 95134
Telephone No.: (408) 952-6000
Fax: (408) 954-9058
Customer No. 20178



**UNITED STATES DEPARTMENT OF COMMERCE
Patent and Trademark Office**

Address: COMMISSIONER OF PATENTS AND TRADEMARKS
Washington, D.C. 20231

APPLICATION NO.	FILING DATE	FIRST NAMED INVENTOR	ATTORNEY DOCKET NO.
09/321,687	05/28/99	FUNAMOTO	T P1933.D2

020178 MM92/0705
EPSON RESEARCH AND DEVELOPMENT INC
INTELLECTUAL PROPERTY DEPT
150 RIVER OAKS PARKWAY, SUITE 225
SAN JOSE CA 95134

EXAMINER

MALINOWSKI, W

ART UNIT

PAPER NUMBER

2871

DATE MAILED: 07/05/00

Please find below and/or attached an Office communication concerning this application or proceeding.

Commissioner of Patents and Trademarks

Response to Rule 312 Communication

Application No. 09/321,687	Applicant(s) FUNAMOTO ET AL.	
Examiner Walter Malinowski	Art Unit 2871	

-- The MAILING DATE of this communication appears on the cover sheet with the correspondence address --

- 1. The petition filed on _____ under 37 CFR 1.312(b) is granted. The paper has been forwarded to the examiner for consideration on the merits.
- 2. The petition filed on _____ under 37 CFR 1.312(b) is dismissed.
 - a) The requisite petition fee of \$ _____ has not been received.
 - b) Other :

Supervisory Patent Examiner
Technology Center

- 3. The amendment filed on 07 March 2000 under 37 CFR 1.312 has been considered, and has been:
 - a) entered.
 - b) entered as directed to matters of form not affecting the scope of the invention.
 - c) disapproved. See explanation below.
 - d) entered in part. See explanation below.

William L. Sines
WILLIAM L. SINES
SUPERVISORY PATENT EXAMINER
GROUP 2800

7540
094 31.100 WO

CE
AP 4/13

P1933.D2

Ok to Enter

MAR 13 2000

Batch No. B84

PATENT

IN THE UNITED STATES PATENT AND TRADEMARK OFFICE

INVENTOR(S): TATSUAKI FUNAMOTO GROUP ART UNIT: 2871
SERIAL NO.: 09/321,687 EXAMINER: W. Malinowski
FILED: 05/28/99
TITLE: SURFACE-TYPE ILLUMINATION DEVICE AND LIQUID CRYSTAL
DISPLAY

CHANGE OF CORRESPONDENCE ADDRESS

Assistant Commissioner for Patents
Washington, D. C. 20231

Sir:

In connection with the above-identified patent application,
please change the address of the attorneys of record to:

Epson Research and Development, Inc.
Intellectual Property Dept.
150 River Oaks Parkway, Suite 225
San Jose, CA 95134
Telephone: (408) 952-6000
Facsimile: (408) 954-9058

Customer Number: 20178

It is certified that the person whose signature appears below
has the authority to change the correspondence address for the
application.

Respectfully submitted,

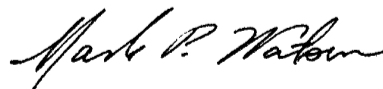

Mark P. Watson
Registration No.: 31,448
Attorney for Applicant(s)

Date: 02/29 /2000



UNITED STATES DEPARTMENT OF COMMERCE
Patent and Trademark Office

ASSISTANT SECRETARY AND COMMISSIONER
OF PATENTS AND TRADEMARKS
Washington, D.C. 20231

CHANGE OF ADDRESS/POWER OF ATTORNEY

FILE LOCATION 9200 SERIAL NUMBER 09321687 PATENT NUMBER 6108060

THE CORRESPONDENCE ADDRESS HAS BEEN CHANGED TO CUSTOMER # 20178

THE PRACTITIONERS OF RECORD HAVE BEEN CHANGED TO CUSTOMER # 20178

THE FEE ADDRESS HAS BEEN CHANGED TO CUSTOMER # 20178

ON 08/05/01 THE ADDRESS OF RECORD FOR CUSTOMER NUMBER 20178 IS:

EPSON RESEARCH AND DEVELOPMENT INC
INTELLECTUAL PROPERTY DEPT
150 RIVER OAKS PARKWAY, SUITE 225
SAN JOSE CA 95134

AND THE PRACTITIONERS OF RECORD FOR CUSTOMER NUMBER 20178 ARE:

31448 32896 42633

PTO INSTRUCTIONS: PLEASE TAKE THE FOLLOWING ACTION WHEN THE
CORRESPONDENCE ADDRESS HAS BEEN CHANGED TO CUSTOMER NUMBER:
RECORD, ON THE NEXT AVAILABLE CONTENTS LINE OF THE FILE JACKET,
'ADDRESS CHANGE TO CUSTOMER NUMBER'. LINE THROUGH THE OLD
ADDRESS ON THE FILE JACKET LABEL AND ENTER ONLY THE 'CUSTOMER
NUMBER' AS THE NEW ADDRESS. FILE THIS LETTER IN THE FILE JACKET.
WHEN ABOVE CHANGES ARE ONLY TO FEE ADDRESS AND/OR PRACTITIONERS
OF RECORD, FILE LETTER IN THE FILE JACKET.
THIS FILE IS ASSIGNED TO GAU 2871.

APPROVED	O.G. FIG. 160+15
BY	1933-02
DRAFTSMAN	CLASS 349 SUBCLASS 065

6108060

1 / 12

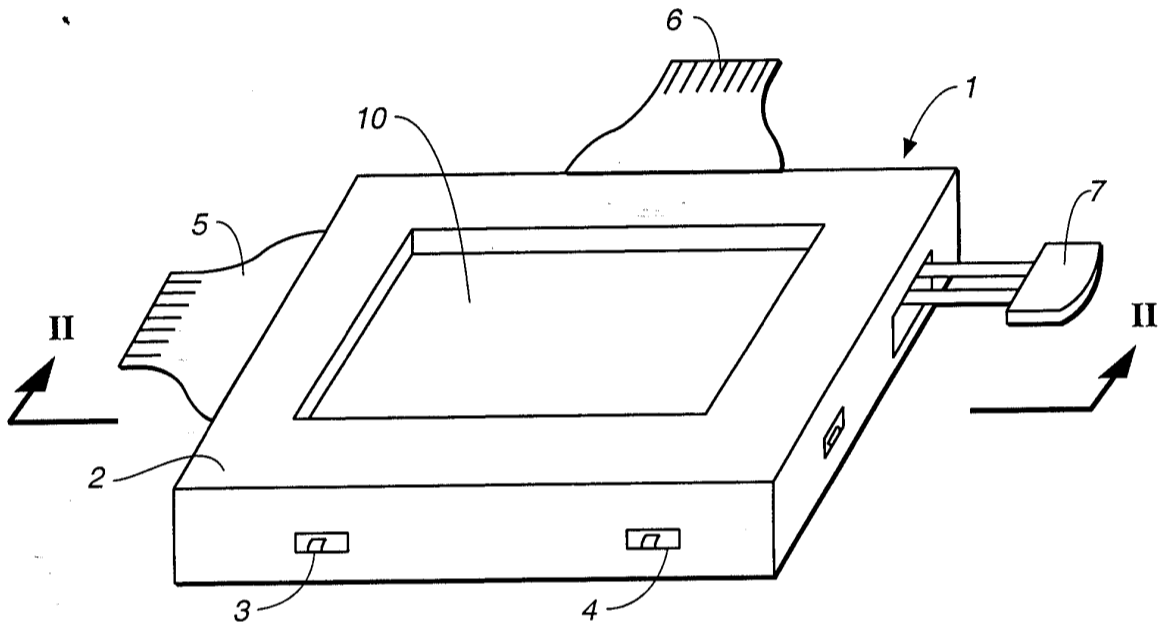

FIG. 1

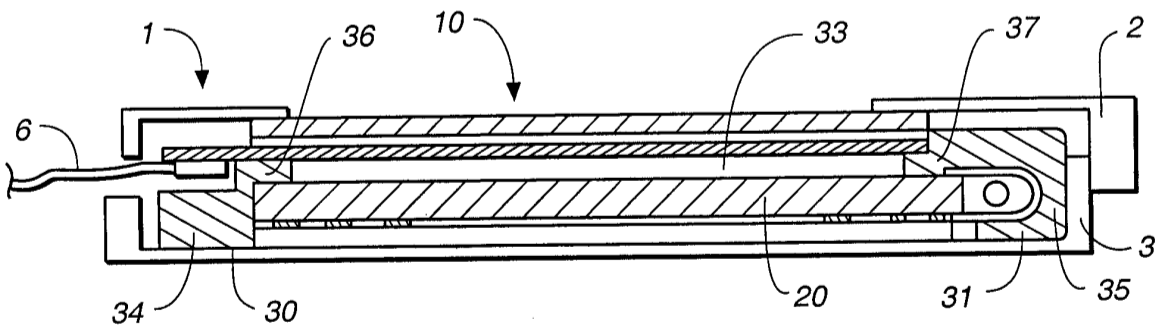

FIG. 2

6108060-160+15

214
+
Fig. 27

APPROVED	O.G. FIG.
BY	CLAYTON J. DASS
DRAFTSMAN	P1933.D2

09331697 09331699
 09331698 09331696

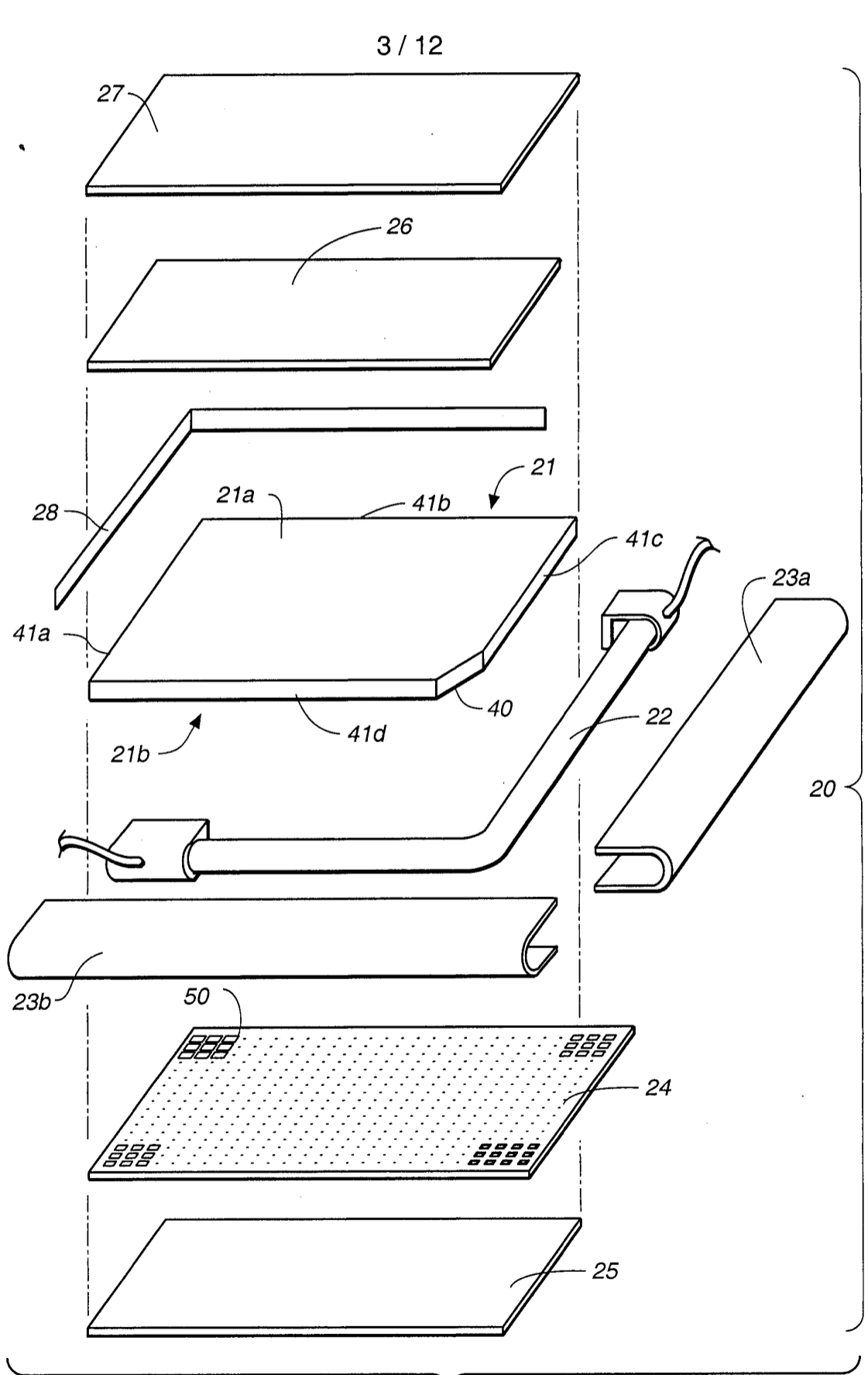
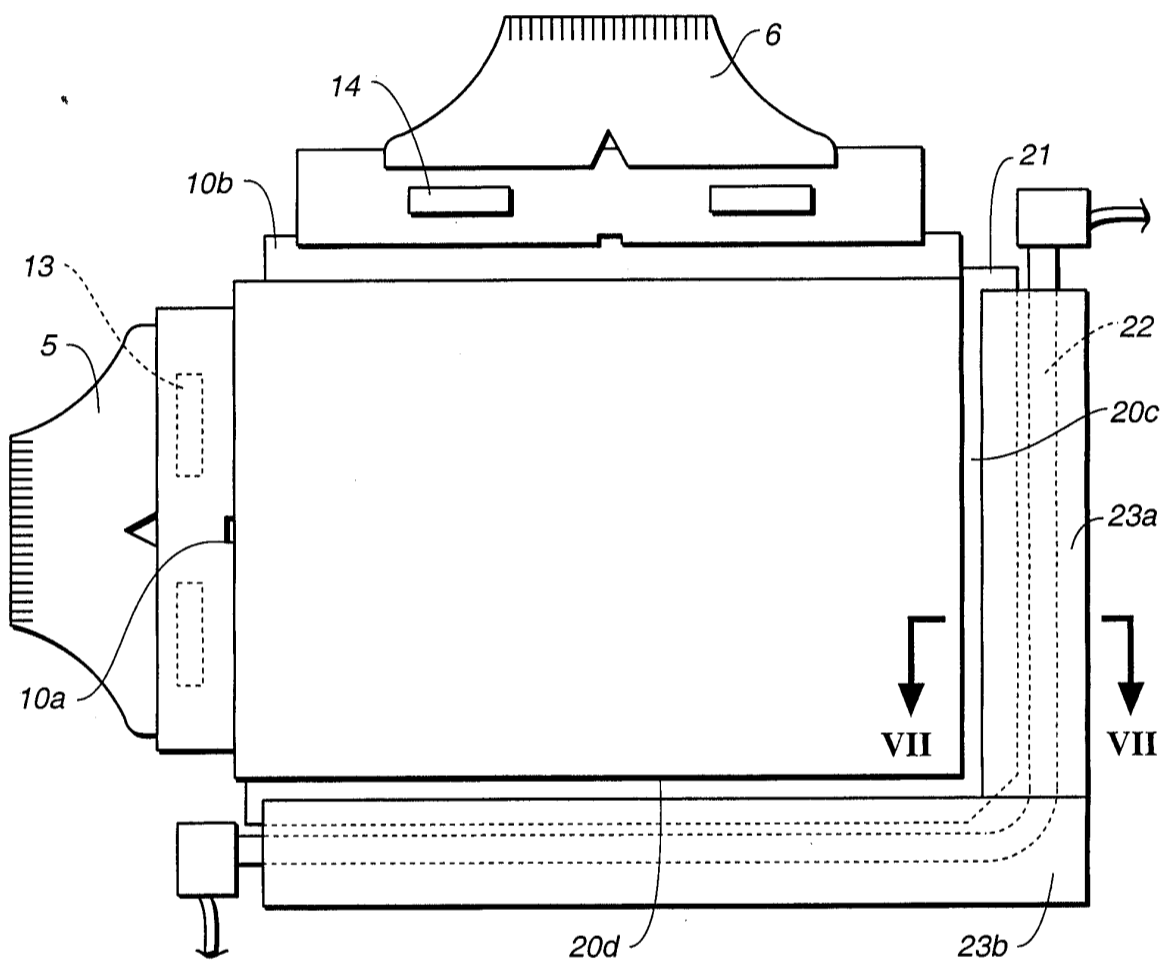

FIG. 4

APPROVED	O.G. FIG.
BY	CLASSIFIED
DRAFTSMAN	1958:02

+

4 / 12



LGE_000958

FIG. 5

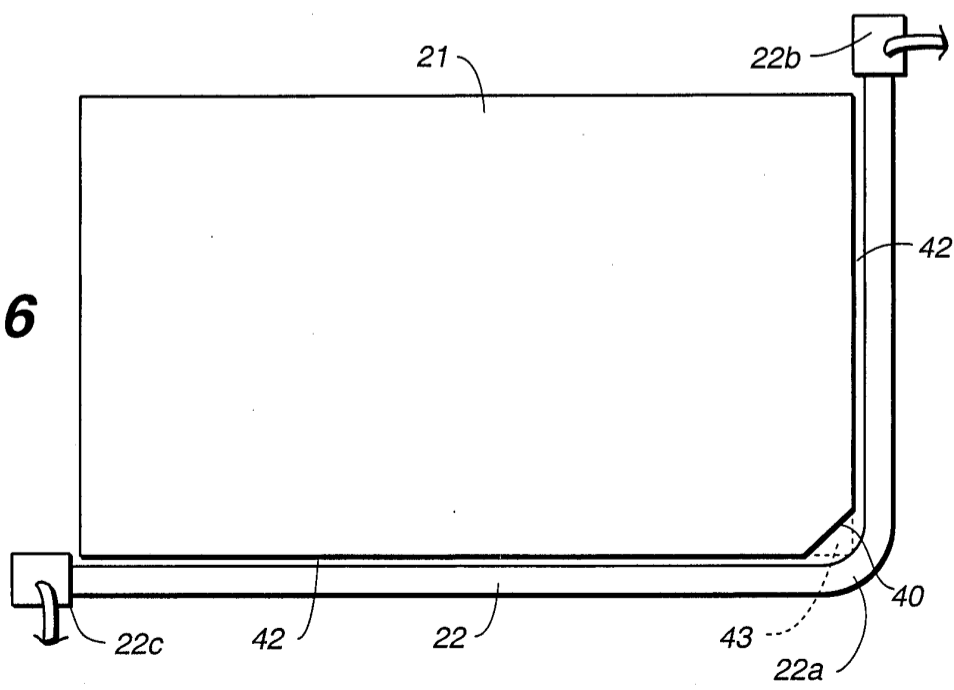

FIG. 6

+

APPROVED	O.G. FIG
BY	P. 1933.D2
DRAFTSMAN	CLASS SUBCLASS

5 / 12

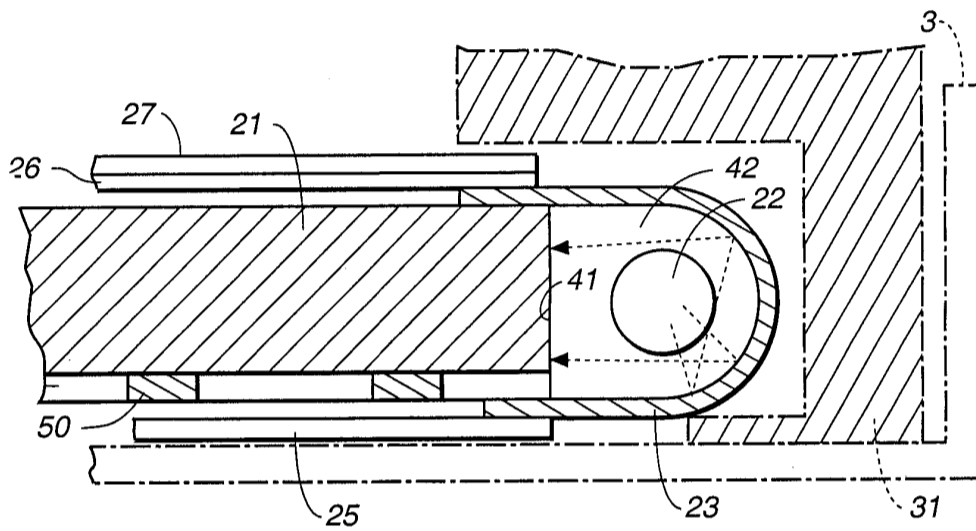

FIG. 7

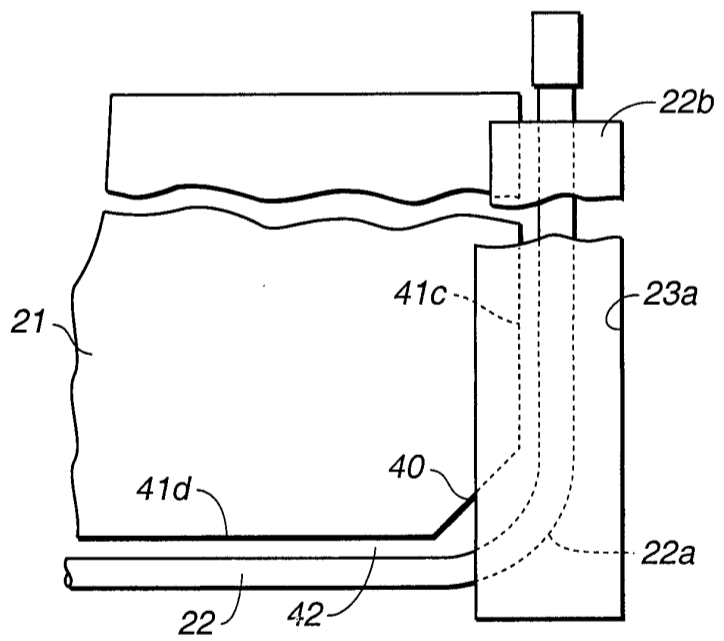

FIG. 8A

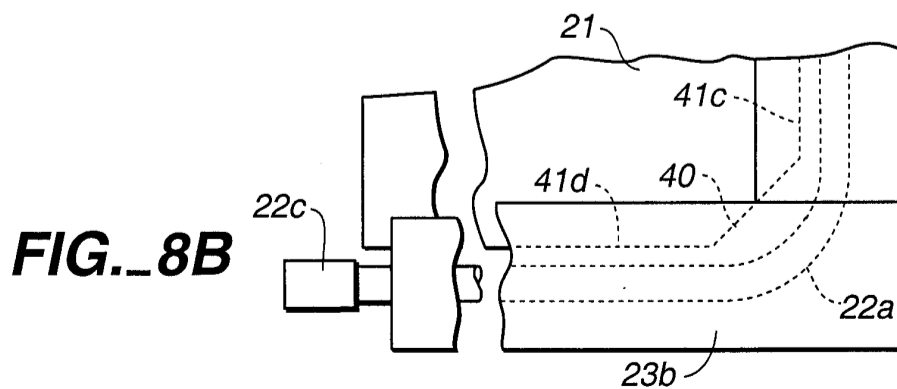

FIG. 8B

66220 78973660

APPROVED	O.G. FIG. 10B+13	
BY	CLASS	1993 D2
DRAFTSMAN	349	065

+

6 / 12

FIG._9

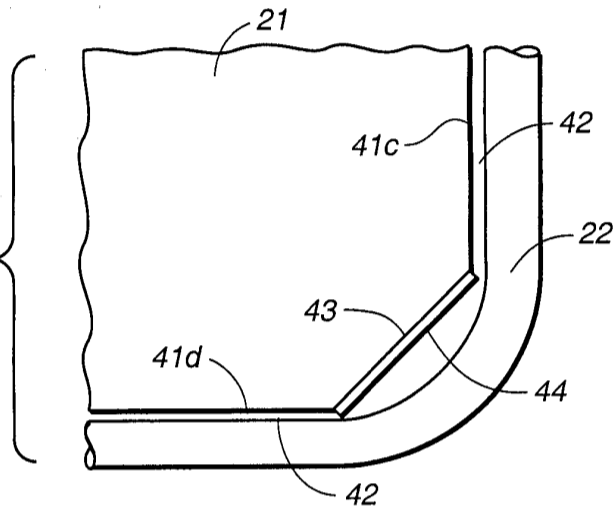

LGE_000960

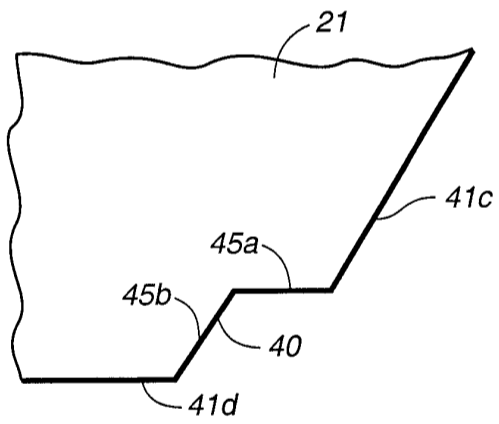

FIG._10A

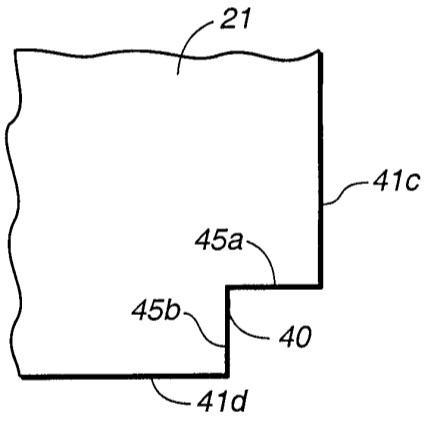

FIG._10B

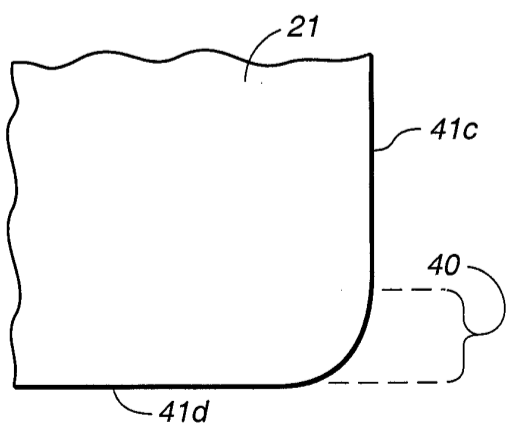

FIG._10C

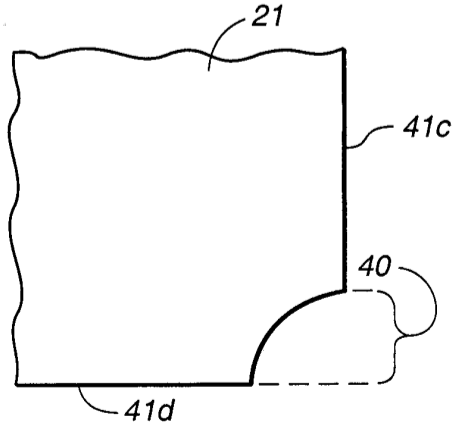

FIG._10D

+

APPROVED	O.G. FIG.	
BY	CLASS	SUBCLASS
DRAFTSMAN	F1935.D2	

+

7 / 12

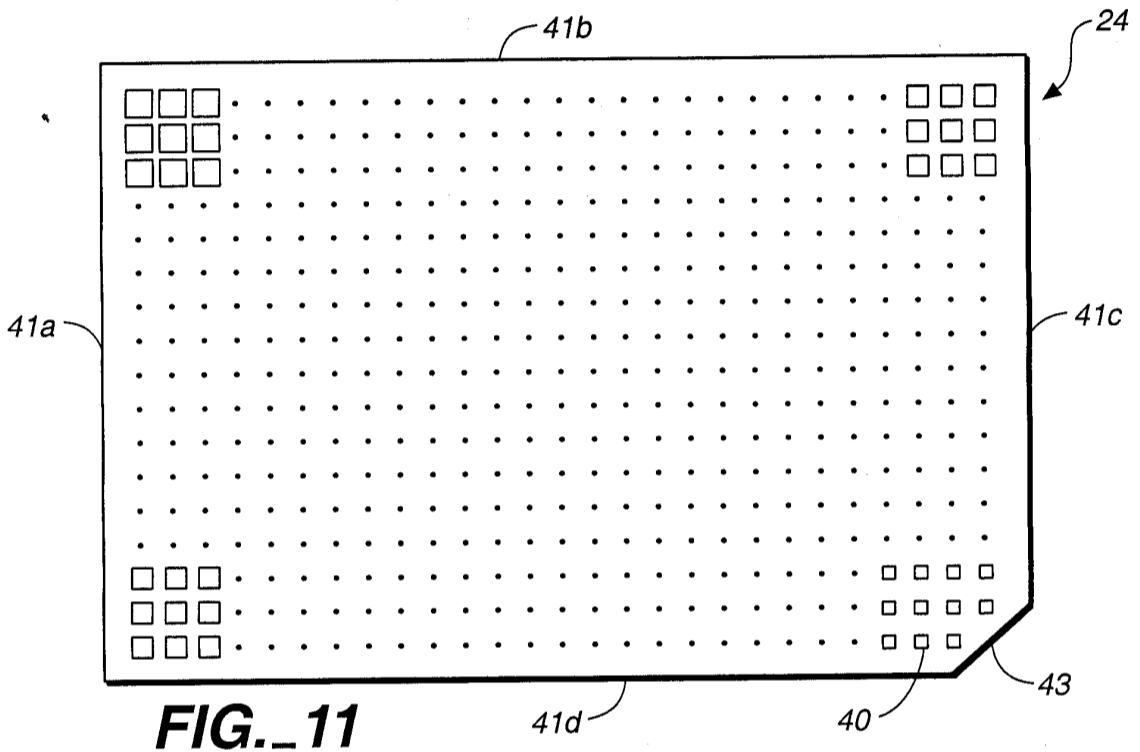

FIG. 11

09331697 2892660

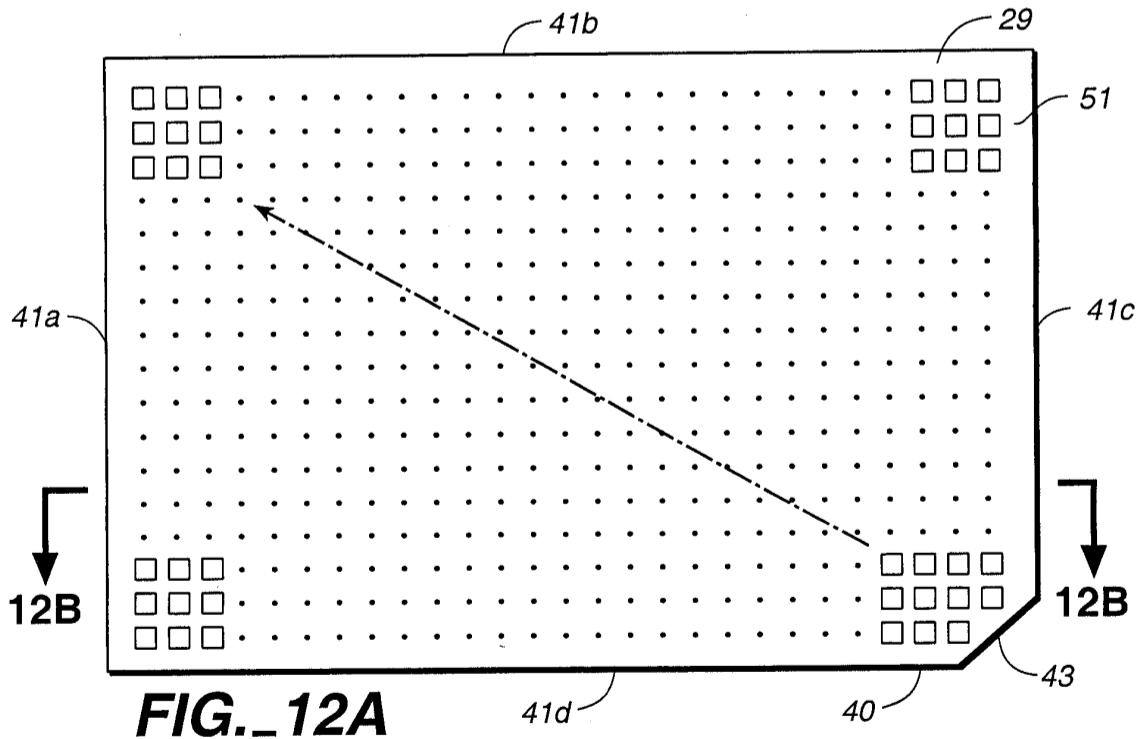

FIG. 12A

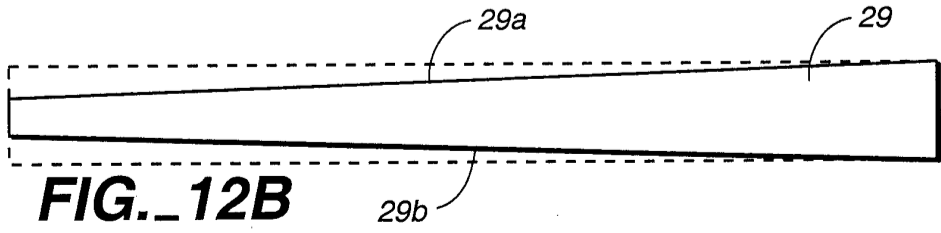

FIG. 12B

+

APPROVED	O.G. FIG. 10B + 15
BY	CLASS P1000.02
DRAFTSMAN	349 065

+

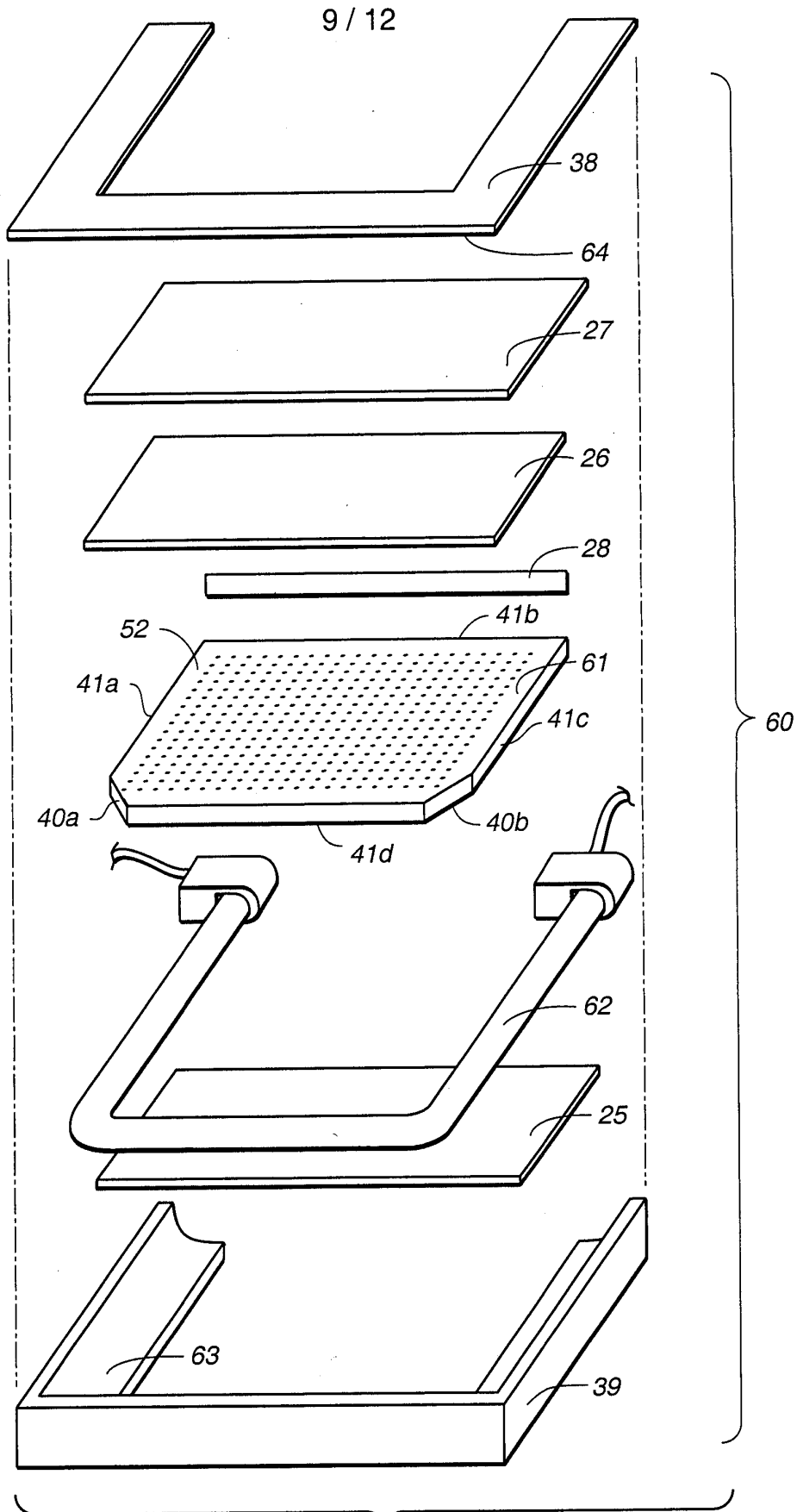

FIG. 15

+

APPROVED	O.G. FIG.
BY	CLASSIFIED
DRAFTSMAN	1989-02

10 / 12

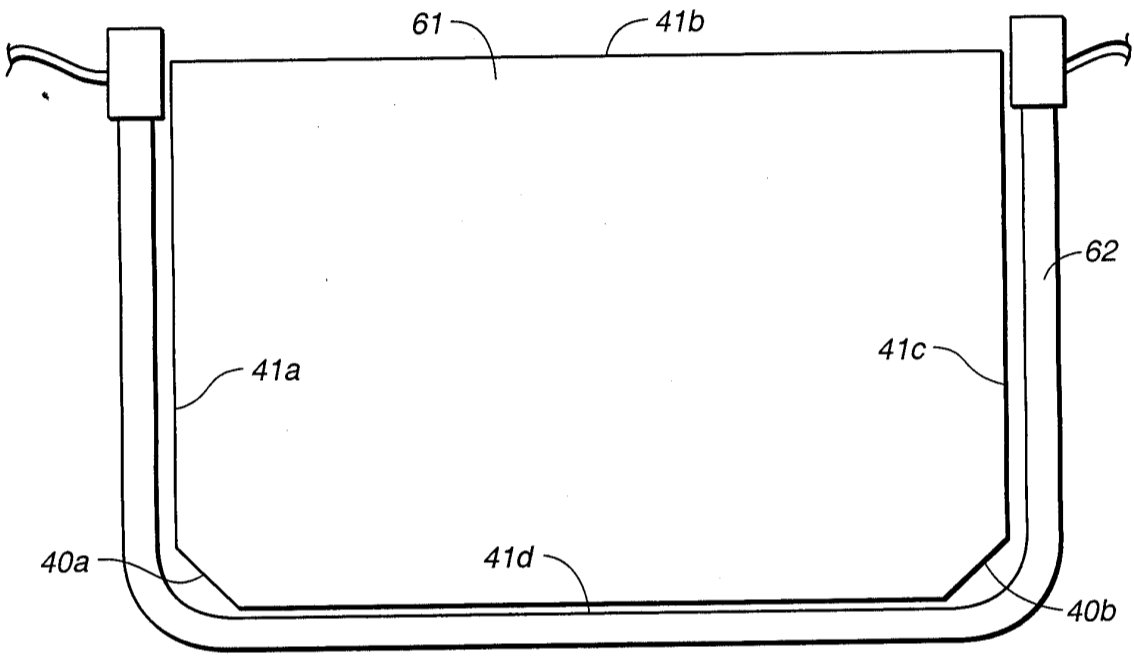

FIG. 16

09321567-053330

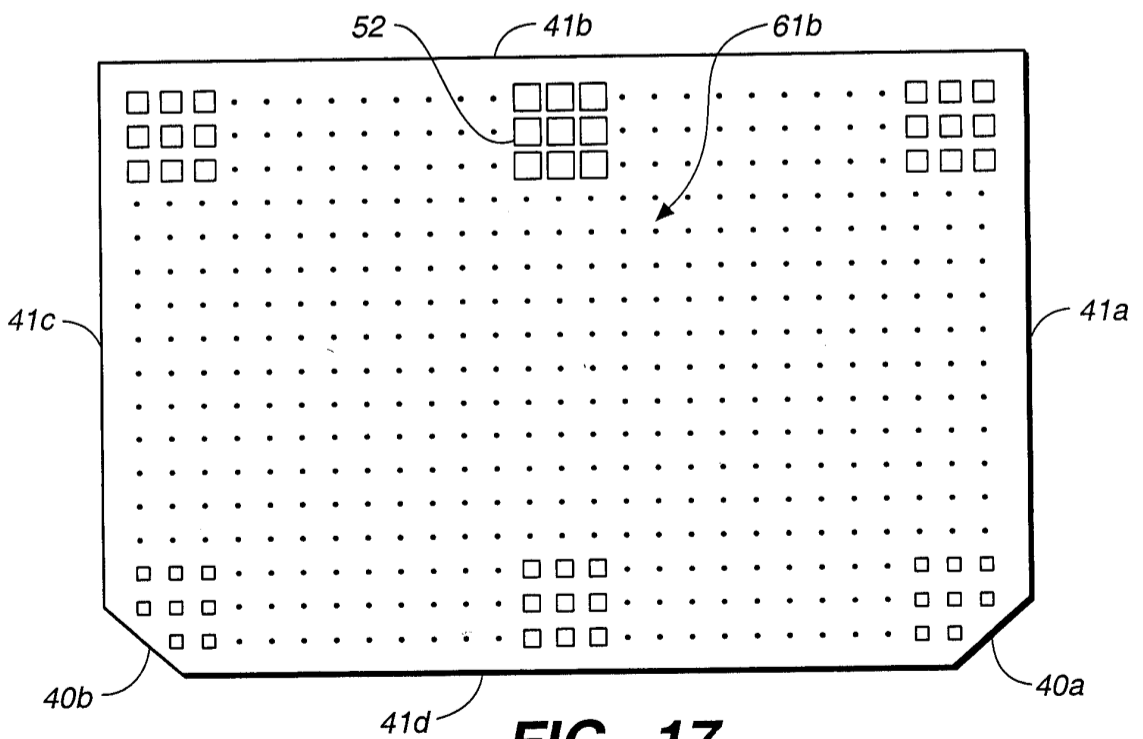

FIG. 17

APPROVED	O.G. FIG.	
BY	CLASS	SUBCLASS
DRAFTSMAN	P1933.D2	

+

11 / 12

FIG._18

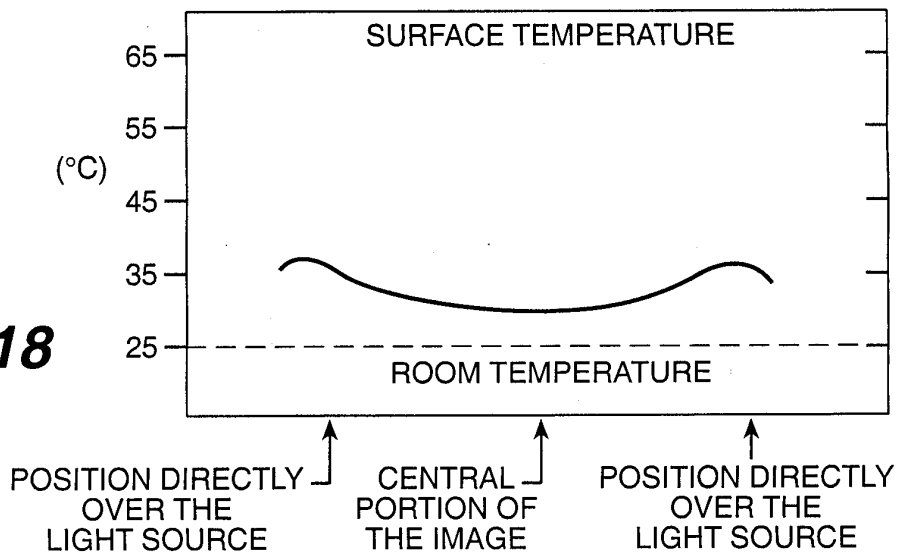

66250 / 247250

FIG._19

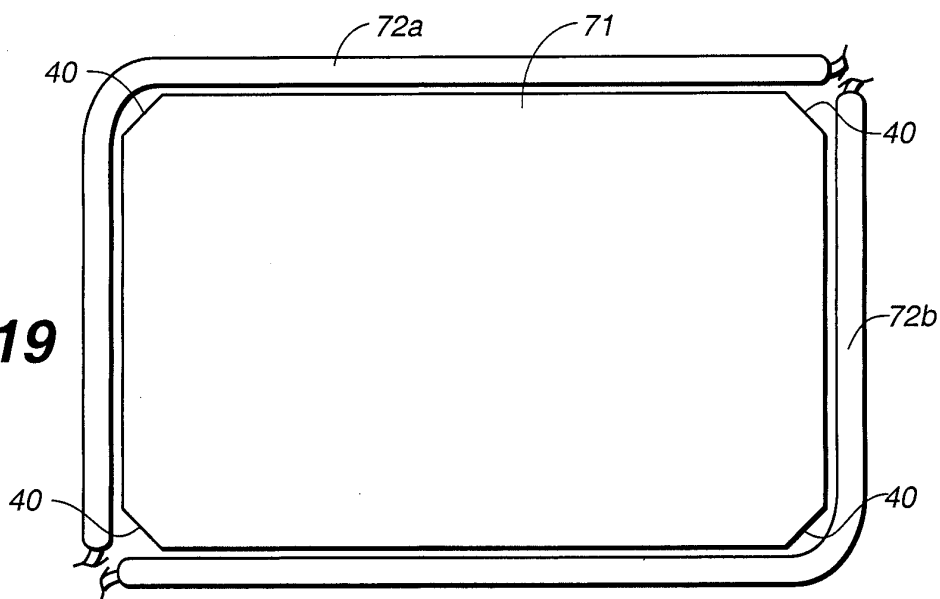
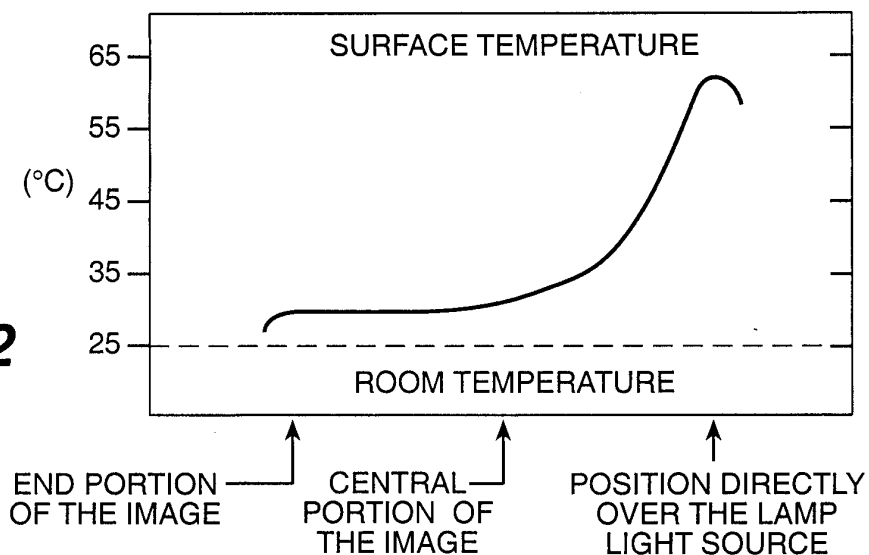

FIG._22



+

APPROVED	O.G. FIG.	
BY	CLASS	SUBCLASS
DRAFTSMAN		

12 / 12

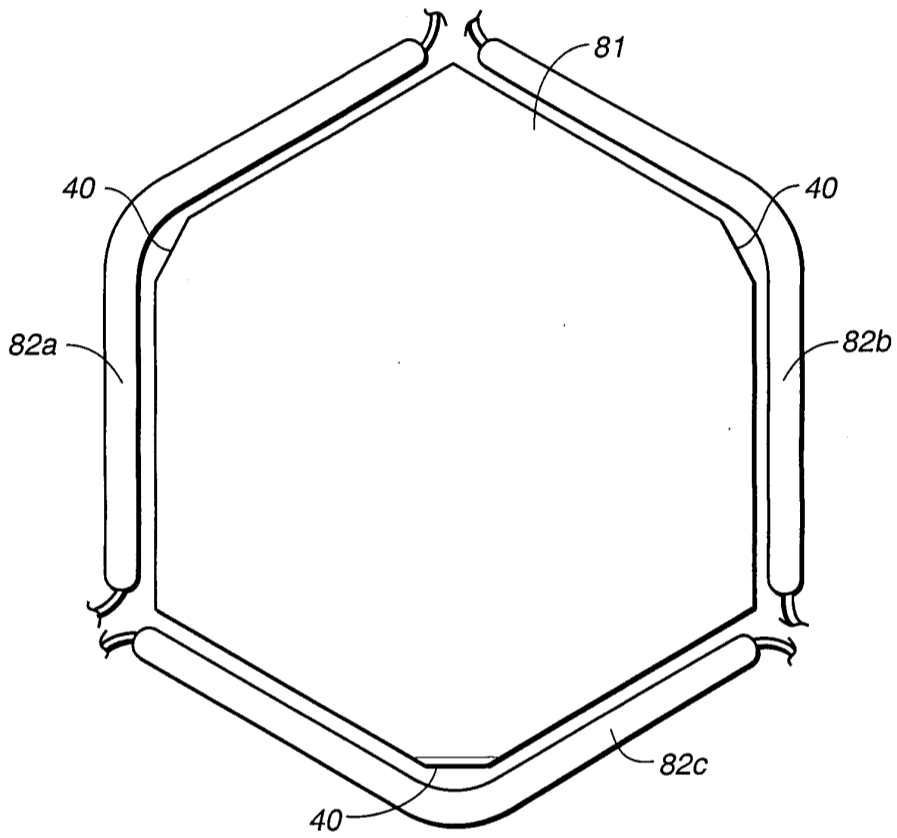

FIG. 20

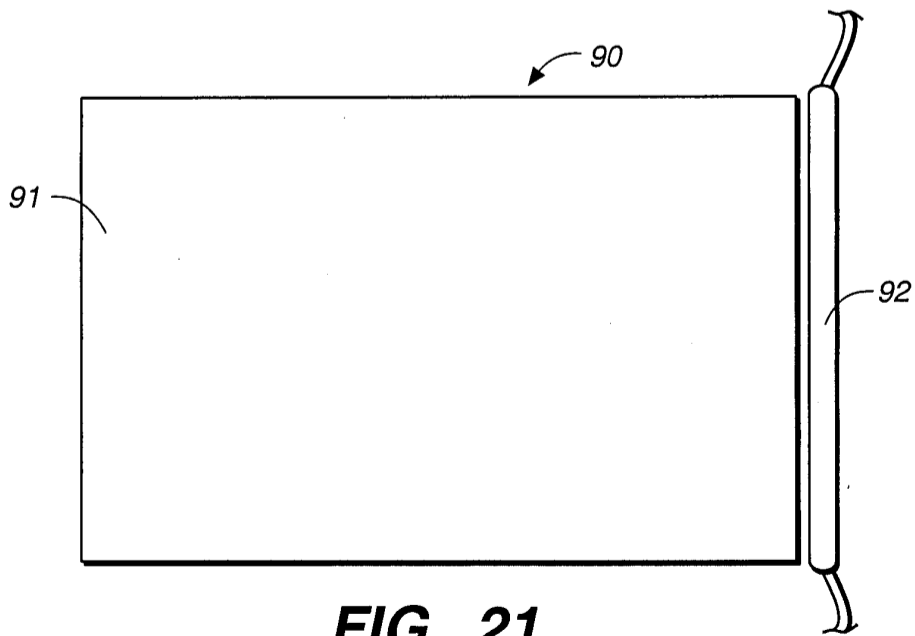
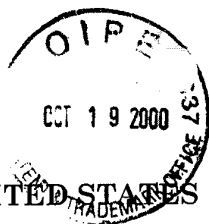

FIG. 21

LGE_000966



#89
BS PATENT
C of C
F

P1933.D2

IN THE UNITED STATES PATENT AND TRADEMARK OFFICE

Patent Number: 6,108,060

Issued: August 22, 2000

Name of Patentee: Tatsuaki Funamoto, et al.

Serial No.: 09/321,687

Filing Date: May 28, 1999

Title of Invention: Surface-Type Illumination Device And Liquid Crystal Display

PUBLISH

CERTIFICATE OF MAILING

I hereby certify that this correspondence, and the documents attached hereto, are being deposited with the United States Postal Service as First Class mail in an envelope addressed to Assistant Commissioner for Patents, Washington, D.C. 20231 on this date.

Date: October 17, 2000

Ann F. George
Ann F. George

REQUEST FOR CERTIFICATE OF CORRECTION OF PATENT FOR PTO MISTAKE (37 CFR 1.322(a))

CERTIFICATE OF CORRECTION
NOV 20 2000

Assistant Commissioner for Patents
Washington, D.C. 20231

ATTENTION: Decision and Certificate of Correction Branch of the Patent Issue Division

Sir:

It is noted that errors appear in this patent of a clerical, typographical or minor nature or character, as more fully described below, due to a mistake by the Patent and Trademark Office.

Attached hereto in duplicate is Form PTO-1050 with at least one copy being suitable for printing.

The exact page and line number where the error occurs in the patent are:

Title page, item 30, Foreign Application Priority Data, please add --July 13, 1992 [JP] Japan 4-184976--.

APPROVED
MAR 27 2001
FOR THE DIRECTOR OF USPTO

Patent No. 6,108,060

REQUEST FOR CERTIFICATE OF CORRECTION OF
PATENT FOR PTO MISTAKE (37 CFR 1.322(a))

Patentee's undersigned attorney may be reached at the telephone number listed below. All correspondence should continue to be directed to our below listed address.

Respectfully submitted,



Mark P. Watson
Attorney for Patentee
Registration No. 31,448

Please address all correspondence to:
Epson Research and Development, Inc.
Intellectual Property Department
150 River Oaks Parkway, Suite 225
San Jose, CA 95134
Customer No. 20178
Phone: (408) 952-6000
Fax: (408) 954-9058

Date: October 17, 2000

UNITED STATES PATENT AND TRADEMARK OFFICE
CERTIFICATE OF CORRECTION

PATENT NO. : 6,108,060
DATED : August 22, 2000
INVENTOR(S) : Tatsuaki Funamoto, et al.

It is certified that an error appears in the above identified patent and that said Letters Patent is hereby corrected as shown below:

Title page, item 30, Foreign Application Priority Data, please add --July 13, 1992 [JP] Japan 4-184976--.

MAILING ADDRESS OF SENDER:

PATENT NO. 6,108,060

Epson Research and Development, Inc.
Intellectual Property Department
150 River Oaks Parkway, Suite 225
San Jose, CA 95134
Customer No. 20178

No. of add'l copies
@ 50¢ per page

[_____]

FORM PTO 1050 (rev.2-93)

correq
Customer No. 20178

REV 11/97



UNITED STATES DEPARTMENT OF COMMERCE
Patent and Trademark Office

NOTICE OF ALLOWANCE AND ISSUE FEE DUE

020178 MM21/0922
EPSON RESEARCH AND DEVELOPMENT INC
INTELLECTUAL PROPERTY DEPT
225 BAYPOINTE PARKWAY
SAN JOSE CA 95134

APPLICATION NO.	FILING DATE	TOTAL CLAIMS	EXAMINER AND GROUP ART UNIT	DATE MAILED
09/321,687	05/28/99	012	MALINOWSKI, W 2871	09/22/99
First Named Applicant	FUNAMOTO,		35 USC 154(b) term ext. =	0 Days.

TITLE OF INVENTION: SURFACE-TYPE ILLUMINATION DEVICE AND LIQUID CRYSTAL DISPLAY

ATTY'S DOCKET NO.	CLASS-SUBCLASS	BATCH NO.	APPLN. TYPE	SMALL ENTITY	FEE DUE	DATE DUE
2 P1933.D2	349-065,000	B84	UTILITY	NO	\$1210.00	12/22/99

THE APPLICATION IDENTIFIED ABOVE HAS BEEN EXAMINED AND IS ALLOWED FOR ISSUANCE AS A PATENT. PROSECUTION ON THE MERITS IS CLOSED.

THE ISSUE FEE MUST BE PAID WITHIN THREE MONTHS FROM THE MAILING DATE OF THIS NOTICE OR THIS APPLICATION SHALL BE REGARDED AS ABANDONED. THIS STATUTORY PERIOD CANNOT BE EXTENDED.

HOW TO RESPOND TO THIS NOTICE:

Review the SMALL ENTITY status shown above.
If the SMALL ENTITY is shown as YES, verify your current SMALL ENTITY status:

- A. If the status is changed, pay twice the amount of the FEE DUE shown above and notify the Patent and Trademark Office of the change in status, or
- B. If the status is the same, pay the FEE DUE shown above.

If the SMALL ENTITY is shown as NO:

- A. Pay FEE DUE shown above, or
- B. File verified statement of Small Entity Status before, or with, payment of 1/2 the FEE DUE shown above.

Part B-Issue Fee Transmittal should be completed and returned to the Patent and Trademark Office (PTO) with your ISSUE FEE. Even if the ISSUE FEE has already been paid by charge to deposit account, Part B Issue Fee Transmittal should be completed and returned. If you are charging the ISSUE FEE to your deposit account, section "4b" of Part B-Issue Fee Transmittal should be completed and an extra copy of the form should be submitted.

I. All communications regarding this application must give application number and batch number. Please direct all communications prior to issuance to Box ISSUE FEE unless advised to the contrary.

IMPORTANT REMINDER: Utility patents issuing on applications filed on or after Dec. 12, 1980 may require payment of maintenance fees. It is patentee's responsibility to ensure timely payment of maintenance fees when due.

PATENT AND TRADEMARK OFFICE COPY

PART B—ISSUE FEE TRANSMITTAL

Complete and mail this form, together with applicable fees, to: **Box ISSUE FEE Assistant Commissioner for Patents, Washington, D.C. 20231**

SEP 27 1999

BF

MAILING INSTRUCTIONS: This form should be used for transmitting the ISSUE FEE. Blocks 1 through 4 should be completed where appropriate. All further correspondence including the Issue Fee Receipt, the Patent, advance orders and notification of maintenance fees will be mailed to the current correspondence address as indicated unless corrected below or directed otherwise in Block 1, by (a) specifying a new correspondence address; and/or (b) indicating a separate "FEE ADDRESS" for maintenance fee notifications.

CURRENT CORRESPONDENCE ADDRESS (Note: Legibly mark-up with any corrections or use Block 1)

020178 MM21/0922
EPSON RESEARCH AND DEVELOPMENT INC.
INTELLECTUAL PROPERTY DEPT
225 BAYPOINTE PARKWAY
SAN JOSE CA 95134

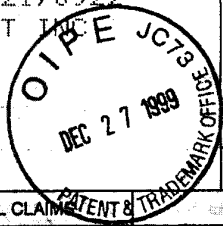

Note: The certificate of mailing below can only be used for domestic mailings of the Issue Fee Transmittal. This certificate cannot be used for any other accompanying papers. Each additional paper, such as an assignment or formal drawing, must have its own certificate of mailing.

Certificate of Mailing

I hereby certify that this Issue Fee Transmittal is being deposited with the United States Postal Service with sufficient postage for first class mail in an envelope addressed to the Box Issue Fee address above on the date indicated below.

Shellie Bailey (Depositor's name)
Shellie Bailey (Signature)
December 20, 1999 (Date)

APPLICATION NO.	FILING DATE	TOTAL CLAIMS	EXAMINER AND GROUP ART UNIT	DATE MAILED
09/321,687	05/28/99	012	MALINOWSKI, W 2871	09/22/99

First Named Applicant: FUNAMOTO, 35 USC 154(b) term ext. = 0 Days.

TITLE OF INVENTION: SURFACE-TYPE ILLUMINATION DEVICE AND LIQUID CRYSTAL DISPLAY

ATTY'S DOCKET NO.	CLASS-SUBCLASS	BATCH NO.	APPLN. TYPE	SMALL ENTITY	FEE DUE	DATE DUE
2 P1933.D2	349-065.000	B84	UTILITY	NO	\$1210.00	12/22/99

1. Change of correspondence address or indication of "Fee Address" (37 CFR 1.363). Use of PTO form(s) and Customer Number are recommended, but not required.

- Change of correspondence address (or Change of Correspondence Address form PTO/SB/122) attached.
- "Fee Address" indication (or "Fee Address" Indication form PTO/SB/47) attached.

2. For printing on the patent front page, list (1) the names of up to 3 registered patent attorneys or agents OR, alternatively, (2) the name of a single firm (having as a member a registered attorney or agent) and the names of up to 2 registered patent attorneys or agents. If no name is listed, no name will be printed.

- 1 Mark P. Watson
- 2 _____
- 3 _____

3. ASSIGNEE NAME AND RESIDENCE DATA TO BE PRINTED ON THE PATENT (print or type)
PLEASE NOTE: Unless an assignee is identified below, no assignee data will appear on the patent. Inclusion of assignee data is only appropriate when an assignment has been previously submitted to the PTO or is being submitted under separate cover. Completion of this form is NOT a substitute for filing an assignment.

(A) NAME OF ASSIGNEE: **Seiko Epson Corporation**
(B) RESIDENCE: (CITY & STATE OR COUNTRY) **Tokyo, Japan**

Please check the appropriate assignee category indicated below (will not be printed on the patent)
 Individual corporation or other private group entity government

4a. The following fees are enclosed (make check payable to Commissioner of Patents and Trademarks):

- Issue Fee
- Advance Order - # of Copies _____

4b. The following fees or deficiency in these fees should be charged to:

DEPOSIT ACCOUNT NUMBER 19-2746
(ENCLOSE AN EXTRA COPY OF THIS FORM)

- Issue Fee
- Advance Order - # of Copies 10

The COMMISSIONER OF PATENTS AND TRADEMARKS IS requested to apply the Issue Fee to the application identified above.

(Authorized Signature) *Mark P. Watson* (Date) 12/20/99
Mark P. Watson, Reg. No. 31,448

NOTE: The Issue Fee will not be accepted from anyone other than the applicant; a registered attorney or agent; or the assignee or other party in interest as shown by the records of the Patent and Trademark Office.

Burden Hour Statement: This form is estimated to take 0.2 hours to complete. Time will vary depending on the needs of the individual case. Any comments on the amount of time required to complete this form should be sent to the Chief Information Officer, Patent and Trademark Office, Washington, D.C. 20231. DO NOT SEND FEES OR COMPLETED FORMS TO THIS ADDRESS. SEND FEES AND THIS FORM TO: Box Issue Fee, Assistant Commissioner for Patents, Washington D.C. 20231

Under the Paperwork Reduction Act of 1995, no persons are required to respond to a collection of information unless it displays a valid OMB control number.

12/28/1999 MBERHE1 00000131 192746
01 FC:142 1210.00 CH
02 FC:561 30.00 CH

TRANSMIT THIS FORM WITH FEE

